

# Sun™ StorEdge™ L280 Service Manual

---



## *Autoloader/Library Tape Storage*



THE NETWORK IS THE COMPUTER™

A Sun Microsystems, Inc. Business  
901 San Antonio Road  
Palo Alto, CA 94303-4900 USA  
1 650 960-1300 fax 1 650 969-9131

Part No. 805-3958-10  
Revision A, February 1998

Send comments about this document to: [smcc-docs@sun.com](mailto:smcc-docs@sun.com)

Copyright 1998 Sun Microsystems, Inc., 901 San Antonio Road • Palo Alto, CA 94303-4900 USA. All rights reserved.

This product or document is protected by copyright and distributed under licenses restricting its use, copying, distribution, and decompilation. No part of this product or document may be reproduced in any form by any means without prior written authorization of Sun and its licensors, if any. Third-party software, including font technology, is copyrighted and licensed from Sun suppliers.

Parts of the product may be derived from Berkeley BSD systems, licensed from the University of California. UNIX is a registered trademark in the U.S. and other countries, exclusively licensed through X/Open Company, Ltd.

Sun, Sun Microsystems, the Sun logo, AnswerBook, Java, the Java Coffee Cup logo, and Solaris are trademarks, registered trademarks, or service marks of Sun Microsystems, Inc. in the U.S. and other countries. All SPARC trademarks are used under license and are trademarks or registered trademarks of SPARC International, Inc. in the U.S. and other countries. Products bearing SPARC trademarks are based upon an architecture developed by Sun Microsystems, Inc.

The OPEN LOOK and Sun™ Graphical User Interface was developed by Sun Microsystems, Inc. for its users and licensees. Sun acknowledges the pioneering efforts of Xerox in researching and developing the concept of visual or graphical user interfaces for the computer industry. Sun holds a non-exclusive license from Xerox to the Xerox Graphical User Interface, which license also covers Sun's licensees who implement OPEN LOOK GUIs and otherwise comply with Sun's written license agreements.

**RESTRICTED RIGHTS:** Use, duplication, or disclosure by the U.S. Government is subject to restrictions of FAR 52.227-14(g)(2)(6/87) and FAR 52.227-19(6/87), or DFAR 252.227-7015(b)(6/95) and DFAR 227.7202-3(a).

DOCUMENTATION IS PROVIDED "AS IS" AND ALL EXPRESS OR IMPLIED CONDITIONS, REPRESENTATIONS AND WARRANTIES, INCLUDING ANY IMPLIED WARRANTY OF MERCHANTABILITY, FITNESS FOR A PARTICULAR PURPOSE OR NON-INFRINGEMENT, ARE DISCLAIMED, EXCEPT TO THE EXTENT THAT SUCH DISCLAIMERS ARE HELD TO BE LEGALLY INVALID.

Copyright 1998 Sun Microsystems, Inc., 901 San Antonio Road • Palo Alto, CA 94303-4900 Etats-Unis. Tous droits réservés.

Ce produit ou document est protégé par un copyright et distribué avec des licences qui en restreignent l'utilisation, la copie, la distribution, et la décompilation. Aucune partie de ce produit ou document ne peut être reproduite sous aucune forme, par quelque moyen que ce soit, sans l'autorisation préalable et écrite de Sun et de ses bailleurs de licence, s'il y en a. Le logiciel détenu par des tiers, et qui comprend la technologie relative aux polices de caractères, est protégé par un copyright et licencié par des fournisseurs de Sun.

Des parties de ce produit pourront être dérivées des systèmes Berkeley BSD licenciés par l'Université de Californie. UNIX est une marque déposée aux Etats-Unis et dans d'autres pays et licenciée exclusivement par X/Open Company, Ltd.

Sun, Sun Microsystems, le logo Sun, AnswerBook, Java, le logo Java Coffee Cup, et Solaris sont des marques de fabrique ou des marques déposées, ou marques de service, de Sun Microsystems, Inc. aux Etats-Unis et dans d'autres pays. Toutes les marques SPARC sont utilisées sous licence et sont des marques de fabrique ou des marques déposées de SPARC International, Inc. aux Etats-Unis et dans d'autres pays. Les produits portant les marques SPARC sont basés sur une architecture développée par Sun Microsystems, Inc.

L'interface d'utilisation graphique OPEN LOOK et Sun™ a été développée par Sun Microsystems, Inc. pour ses utilisateurs et licenciés. Sun reconnaît les efforts de pionniers de Xerox pour la recherche et le développement du concept des interfaces d'utilisation visuelle ou graphique pour l'industrie de l'informatique. Sun détient une licence non exclusive de Xerox sur l'interface d'utilisation graphique Xerox, cette licence couvrant également les licenciés de Sun qui mettent en place l'interface d'utilisation graphique OPEN LOOK et qui en outre se conforment aux licences écrites de Sun.

CETTE PUBLICATION EST FOURNIE "EN L'ETAT" ET AUCUNE GARANTIE, EXPRESSE OU IMPLICITE, N'EST ACCORDEE, Y COMPRIS DES GARANTIES CONCERNANT LA VALEUR MARCHANDE, L'APTITUDE DE LA PUBLICATION A REpondre A UNE UTILISATION PARTICULIERE, OU LE FAIT QU'ELLE NE SOIT PAS CONTREFAISANTE DE PRODUIT DE TIERS. CE DENI DE GARANTIE NE S'APPLIQUERAIT PAS, DANS LA MESURE OU IL SERAIT TENU JURIDIQUEMENT NUL ET NON AVENU.



## Regulatory Compliance Statements

Your Sun product is marked to indicate its compliance class:

- Federal Communications Commission (FCC) — USA
- Department of Communications (DOC) — Canada
- Voluntary Control Council for Interference (VCCI) — Japan

Please read the appropriate section that corresponds to the marking on your Sun product before attempting to install the product.

### FCC Class A Notice

This device complies with Part 15 of the FCC Rules. Operation is subject to the following two conditions:

1. This device may not cause harmful interference.
2. This device must accept any interference received, including interference that may cause undesired operation.

**Note:** This equipment has been tested and found to comply with the limits for a Class A digital device, pursuant to Part 15 of the FCC Rules. These limits are designed to provide reasonable protection against harmful interference when the equipment is operated in a commercial environment. This equipment generates, uses and can radiate radio frequency energy and, if not installed and used in accordance with the instruction manual, may cause harmful interference to radio communications. Operation of this equipment in a residential area is likely to cause harmful interference in which case the user will be required to correct the interference at his own expense.

**Shielded Cables:** Connections between the workstation and peripherals must be made using shielded cables in order to maintain compliance with FCC radio frequency emission limits. Networking connections can be made using unshielded twisted-pair (UTP) cables.

**Modifications:** Any modifications made to this device that are not approved by Sun Microsystems, Inc. may void the authority granted to the user by the FCC to operate this equipment.

### FCC Class B Notice

This device complies with Part 15 of the FCC Rules. Operation is subject to the following two conditions:

1. This device may not cause harmful interference.
2. This device must accept any interference received, including interference that may cause undesired operation.

**Note:** This equipment has been tested and found to comply with the limits for a Class B digital device, pursuant to Part 15 of the FCC Rules. These limits are designed to provide reasonable protection against harmful interference in a residential installation. This equipment generates, uses and can radiate radio frequency energy and, if not installed and used in accordance with the instructions, may cause harmful interference to radio communications. However, there is no guarantee that interference will not occur in a particular installation. If this equipment does cause harmful interference to radio or television reception, which can be determined by turning the equipment off and on, the user is encouraged to try to correct the interference by one or more of the following measures:

- Reorient or relocate the receiving antenna.
- Increase the separation between the equipment and receiver.
- Connect the equipment into an outlet on a circuit different from that to which the receiver is connected.
- Consult the dealer or an experienced radio/television technician for help.

**Shielded Cables:** Connections between the workstation and peripherals must be made using shielded cables in order to maintain compliance with FCC radio frequency emission limits. Networking connections can be made using unshielded twisted pair (UTP) cables.

**Modifications:** Any modifications made to this device that are not approved by Sun Microsystems, Inc. may void the authority granted to the user by the FCC to operate this equipment.

## DOC Class A Notice - Avis DOC, Classe A

This Class A digital apparatus meets all requirements of the Canadian Interference-Causing Equipment Regulations.  
Cet appareil numérique de la classe A respecte toutes les exigences du Règlement sur le matériel brouilleur du Canada.

## DOC Class B Notice - Avis DOC, Classe B

This Class B digital apparatus meets all requirements of the Canadian Interference-Causing Equipment Regulations.  
Cet appareil numérique de la classe B respecte toutes les exigences du Règlement sur le matériel brouilleur du Canada.

## VCCI 基準について

### 第一種VCCI基準について

第一種VCCIの表示があるワークステーションおよびオプション製品は、第一種情報装置です。これらの製品には、下記の項目が該当します。

この装置は、第一種情報装置(商工業地域において使用されるべき情報装置)で商工業地域での電波障害防止を目的とした情報処理装置等電波障害自主規制協議会(VCCI)基準に適合しております。したがって、本製品を、住宅地域または住宅地域に隣接した地域でご使用になりますと、ラジオ、テレビジョン受信機等に受信障害を与えることがあります。

取り扱い説明書に従って正しくお取り扱いください。

### 第二種VCCI基準について

第二種VCCIの表示  があるワークステーションおよびオプション製品は、第二種情報装置です。これらの製品には、下記の項目が該当します。

この装置は、第二種情報装置(住宅地域または住宅地域に隣接した地域において使用されるべき情報装置)で住宅地域での電波障害防止を目的とした情報処理装置等電波障害自主規制協議会(VCCI)基準に適合しております。しかし、本製品を、ラジオ、テレビジョン受信機に近接してご使用になりますと、受信障害の原因となることがあります。

取り扱い説明書に従って正しくお取り扱いください。

## Safety Agency Compliance Statements

Read this section before beginning any procedure. The following text provides safety precautions to follow when installing a Sun Microsystems product.

### Safety Precautions

For your protection, observe the following safety precautions when setting up your equipment:

- Follow all cautions and instructions marked on the equipment.
- Ensure that the voltage and frequency of your power source match the voltage and frequency inscribed on the equipment's electrical rating label.
- Never push objects of any kind through openings in the equipment. Dangerous voltages may be present. Conductive foreign objects could produce a short circuit that could cause fire, electric shock, or damage to your equipment.

### Symbols

The following symbols may appear in this book:



---

**Caution** – There is risk of personal injury and equipment damage. Follow the instructions.

---



---

**Caution** – Hazardous voltages are present. To reduce the risk of electric shock and danger to personal health, follow the instructions.

---



---

**On** – Applies AC power to the system.

---

Depending on the type of power switch your device has, one of the following symbols may be used:



---

**Off** – Removes AC power from the system.

---



---

**Standby** – The On/Standby switch is in the *standby* position.

---

### Modifications to Equipment

Do not make mechanical or electrical modifications to the equipment. Sun Microsystems is not responsible for regulatory compliance of a modified Sun product.

## Placement of a Sun Product



---

**Caution** – Do not block or cover the openings of your Sun product. Never place a Sun product near a radiator or heat register. Failure to follow these guidelines can cause overheating and affect the reliability of your Sun product.

---

### SELV Compliance

Safety status of I/O connections comply to SELV requirements.

### Power Cord Connection



---

**Caution** – Sun products are designed to work with single-phase power systems having a grounded neutral conductor. To reduce the risk of electric shock, do not plug Sun products into any other type of power system. Contact your facilities manager or a qualified electrician if you are not sure what type of power is supplied to your building.

---



---

**Caution** – Not all power cords have the same current ratings. Household extension cords do not have overload protection and are not meant for use with computer systems. Do not use household extension cords with your Sun product.

---



---

**Caution** – Your Sun product is shipped with a grounding type (three-wire) power cord. To reduce the risk of electric shock, always plug the cord into a grounded power outlet.

---

The following caution applies only to devices with a **Standby** power switch:



---

**Caution** – The power switch of this product functions as a standby type device only. The power cord serves as the primary disconnect device for the system. Be sure to plug the power cord into a grounded power outlet that is nearby the system and is readily accessible. Do not connect the power cord when the power supply has been removed from the system chassis.

---

## Einhaltung sicherheitsbehördlicher Vorschriften

Auf dieser Seite werden Sicherheitsrichtlinien beschrieben, die bei der Installation von Sun-Produkten zu beachten sind.

### Sicherheitsvorkehrungen

Treffen Sie zu Ihrem eigenen Schutz die folgenden Sicherheitsvorkehrungen, wenn Sie Ihr Gerät installieren:

- Beachten Sie alle auf den Geräten angebrachten Warnhinweise und Anweisungen.
- Vergewissern Sie sich, daß Spannung und Frequenz Ihrer Stromquelle mit der Spannung und Frequenz übereinstimmen, die auf dem Etikett mit den elektrischen Nennwerten des Geräts angegeben sind.
- Stecken Sie auf keinen Fall irgendwelche Gegenstände in Öffnungen in den Geräten. Leitfähige Gegenstände könnten aufgrund der möglicherweise vorliegenden gefährlichen Spannungen einen Kurzschluß verursachen, der einen Brand, Stromschlag oder Geräteschaden herbeiführen kann.

### Symbole

Die Symbole in diesem Handbuch haben folgende Bedeutung:



**Achtung** – Gefahr von Verletzung und Geräteschaden. Befolgen Sie die Anweisungen.



**Achtung** – Gefährliche Spannungen. Anweisungen befolgen, um Stromschläge und Verletzungen zu vermeiden.



**Ein** – Setzt das System unter Wechselstrom.

Je nach Netzschaltertyp an Ihrem Gerät kann eines der folgenden Symbole benutzt werden:



**Aus** – Unterbricht die Wechselstromzufuhr zum Gerät.



**Wartezustand** (Stand-by-Position) - Der Ein-/Wartezustand-Schalter steht auf Wartezustand. Änderungen an Sun-Geräten.

Nehmen Sie keine mechanischen oder elektrischen Änderungen an den Geräten vor. Sun Microsystems, übernimmt bei einem Sun-Produkt, das geändert wurde, keine Verantwortung für die Einhaltung behördlicher

## Vorschriften

### Aufstellung von Sun-Geräten



**Achtung** – Um den zuverlässigen Betrieb Ihres Sun-Geräts zu gewährleisten und es vor Überhitzung zu schützen, dürfen die Öffnungen im Gerät nicht blockiert oder verdeckt werden. Sun-Produkte sollten niemals in der Nähe von Heizkörpern oder Heizluftklappen aufgestellt werden.

### Einhaltung der SELV-Richtlinien

Die Sicherung der I/O-Verbindungen entspricht den Anforderungen der SELV-Spezifikation.

### Anschluß des Netzkabels



**Achtung** – Sun-Produkte sind für den Betrieb an Einphasen-Stromnetzen mit geerdetem Nulleiter vorgesehen. Um die Stromschlaggefahr zu reduzieren, schließen Sie Sun-Produkte nicht an andere Stromquellen an. Ihr Betriebsleiter oder ein qualifizierter Elektriker kann Ihnen die Daten zur Stromversorgung in Ihrem Gebäude geben.



**Achtung** – Nicht alle Netzkabel haben die gleichen Nennwerte. Herkömmliche, im Haushalt verwendete Verlängerungskabel besitzen keinen Überlastungsschutz und sind daher für Computersysteme nicht geeignet.



**Achtung** – Ihr Sun-Gerät wird mit einem dreiadrigen Netzkabel für geerdete Netzsteckdosen geliefert. Um die Gefahr eines Stromschlags zu reduzieren, schließen Sie das Kabel nur an eine fachgerecht verlegte, geerdete Steckdose an.

Die folgende Warnung gilt nur für Geräte mit Wartezustand-Netzschalter:



**Achtung** – Der Ein/Aus-Schalter dieses Geräts schaltet nur auf Wartezustand (Stand-By-Modus). Um die Stromzufuhr zum Gerät vollständig zu unterbrechen, müssen Sie das Netzkabel von der Steckdose abziehen. Schließen Sie den Stecker des Netzkabels an eine in der Nähe befindliche, frei zugängliche, geerdete Netzsteckdose an. Schließen Sie das Netzkabel nicht an, wenn das Netzteil aus der Systemeinheit entfernt wurde.

## Conformité aux normes de sécurité

Ce texte traite des mesures de sécurité qu'il convient de prendre pour l'installation d'un produit Sun Microsystems.

### Mesures de sécurité

Pour votre protection, veuillez prendre les précautions suivantes pendant l'installation du matériel :

- Suivre tous les avertissements et toutes les instructions inscrites sur le matériel.
- Vérifier que la tension et la fréquence de la source d'alimentation électrique correspondent à la tension et à la fréquence indiquées sur l'étiquette de classification de l'appareil.
- Ne jamais introduire d'objets quels qu'ils soient dans une des ouvertures de l'appareil. Vous pourriez vous trouver en présence de hautes tensions dangereuses. Tout objet conducteur introduit de la sorte pourrait produire un court-circuit qui entraînerait des flammes, des risques d'électrocution ou des dégâts matériels.

### Symboles

Vous trouverez ci-dessous la signification des différents symboles utilisés :



**Attention** : risques de blessures corporelles et de dégâts matériels. Veuillez suivre les instructions.



**Attention** : présence de tensions dangereuses. Pour éviter les risques d'électrocution et de danger pour la santé physique, veuillez suivre les instructions.



**MARCHE** - Votre système est sous tension (courant alternatif).



**ARRÊT** - Votre système est hors tension (courant alternatif).



**VEILLEUSE** - L'interrupteur Marche/Veilleuse est en position « Veilleuse ».

### Modification du matériel

Ne pas apporter de modification mécanique ou électrique au matériel. Sun Microsystems n'est pas responsable de la conformité réglementaire d'un produit Sun qui a été modifié.

## Positionnement d'un produit Sun



**Attention** : pour assurer le bon fonctionnement de votre produit Sun et pour l'empêcher de surchauffer, il convient de ne pas obstruer ni recouvrir les ouvertures prévues dans l'appareil. Un produit Sun ne doit jamais être placé à proximité d'un radiateur ou d'une source de chaleur.

### Conformité SELV

Sécurité : les raccordements E/S sont conformes aux normes SELV.

### Connexion du cordon d'alimentation



**Attention** : les produits Sun sont conçus pour fonctionner avec des alimentations monophasées munies d'un conducteur neutre mis à la terre. Pour écarter les risques d'électrocution, ne pas brancher de produit Sun dans un autre type d'alimentation secteur. En cas de doute quant au type d'alimentation électrique du local, veuillez vous adresser au directeur de l'exploitation ou à un électricien qualifié.



**Attention** : tous les cordons d'alimentation n'ont pas forcément la même puissance nominale en matière de courant. Les rallonges d'usage domestique n'offrent pas de protection contre les surcharges et ne sont pas prévues pour les systèmes d'ordinateurs. Ne pas utiliser de rallonge d'usage domestique avec votre produit Sun.



**Attention** : votre produit Sun a été livré équipé d'un cordon d'alimentation à trois fils (avec prise de terre). Pour écarter tout risque d'électrocution, branchez toujours ce cordon dans une prise mise à la terre.

L'avertissement suivant s'applique uniquement aux systèmes équipés d'un interrupteur VEILLEUSE:



**Attention** : le commutateur d'alimentation de ce produit fonctionne comme un dispositif de mise en veille uniquement. C'est la prise d'alimentation qui sert à mettre le produit hors tension. Veuillez donc à installer le produit à proximité d'une prise murale facilement accessible. Ne connectez pas la prise d'alimentation lorsque le châssis du système n'est plus alimenté.

## Normativas de seguridad

El siguiente texto incluye las medidas de seguridad que se deben seguir cuando se instale algún producto de Sun Microsystems.

### Precauciones de seguridad

Para su protección observe las siguientes medidas de seguridad cuando manipule su equipo:

- Siga todas las avisos e instrucciones marcados en el equipo.
- Asegúrese de que el voltaje y la frecuencia de la red eléctrica concuerdan con las descritas en las etiquetas de especificaciones eléctricas del equipo.
- No introduzca nunca objetos de ningún tipo a través de los orificios del equipo. Pueden haber voltajes peligrosos. Los objetos extraños conductores de la electricidad pueden producir cortocircuitos que provoquen un incendio, descargas eléctricas o daños en el equipo.

### Símbolos

En este libro aparecen los siguientes símbolos:



---

**Precaución** – Existe el riesgo de lesiones personales y daños al equipo. Siga las instrucciones.

---



---

**Precaución** – Voltaje peligroso presente. Para reducir el riesgo de descarga y daños para la salud siga las instrucciones.

---



---

**Encendido** – Aplica la alimentación de CA al sistema.

---

Según el tipo de interruptor de encendido que su equipo tenga, es posible que se utilice uno de los siguientes símbolos:



---

**Apagado** – Elimina la alimentación de CA del sistema.

---



---

**En espera** – El interruptor de Encendido/En espera se ha colocado en la posición de *En espera*.

---

### Modificaciones en el equipo

No realice modificaciones de tipo mecánico o eléctrico en el equipo. Sun Microsystems no se hace responsable del cumplimiento de las normativas de seguridad en los equipos Sun modificados.

## Ubicación de un producto Sun



---

**Precaución** – Para asegurar la fiabilidad de funcionamiento de su producto Sun y para protegerlo de sobrecalentamientos no deben obstruirse o taparse las rejillas del equipo. Los productos Sun nunca deben situarse cerca de radiadores o de fuentes de calor.

---

### Cumplimiento de la normativa SELV

El estado de la seguridad de las conexiones de entrada/salida cumple los requisitos de la normativa SELV.

### Conexión del cable de alimentación eléctrica



---

**Precaución** – Los productos Sun están diseñados para trabajar en una red eléctrica monofásica con toma de tierra. Para reducir el riesgo de descarga eléctrica, no conecte los productos Sun a otro tipo de sistema de alimentación eléctrica. Póngase en contacto con el responsable de mantenimiento o con un electricista cualificado si no está seguro del sistema de alimentación eléctrica del que se dispone en su edificio.

---



---

**Precaución** – No todos los cables de alimentación eléctrica tienen la misma capacidad. Los cables de tipo doméstico no están provistos de protecciones contra sobrecargas y por tanto no son apropiados para su uso con computadores. No utilice alargadores de tipo doméstico para conectar sus productos Sun.

---



---

**Precaución** – Con el producto Sun se proporciona un cable de alimentación con toma de tierra. Para reducir el riesgo de descargas eléctricas conéctelo siempre a un enchufe con toma de tierra.

---



La siguiente advertencia se aplica solamente a equipos con un interruptor de encendido que tenga una posición "En espera":



---

**Precaución** – El interruptor de encendido de este producto funciona exclusivamente como un dispositivo de puesta en espera. El enchufe de la fuente de alimentación está diseñado para ser el elemento primario de desconexión del equipo. El equipo debe instalarse cerca del enchufe de forma que este último pueda ser fácil y rápidamente accesible. No conecte el cable de alimentación cuando se ha retirado la fuente de alimentación del chasis del sistema.

---



# Declaration of Conformity

according to ISO/IEC Guide 22 and EN 45014

**Manufacturer's Name:** Hewlett-Packard Co.  
**Manufacturer's Address:** Storage Systems Division  
700 71st Avenue  
Greeley, CO 80634 USA

**declares, that the product**

**Product Name:** DLT Library

**Model Numbers:** C6282L

**Product Options:** All Options

**conforms to the following Product Specifications:**

**Safety:** EN 60950: 1992+A1+A2:1993+A3:1995/IEC950(1991)+A1+A2+A3  
EN 60825-1 (1994) / IEC825-1 (1993), Laser Class 1

**EMC:** EN 55022 (1994) / CISPR 22 (1993), Class B  
EN 50082-1 (1992)  
prEN 55024-2 (1992) / IEC 1000-4-2 (1995), 4 kV CD, 8 kV AD  
prEN 55024-3 (1991) / IEC 1000-4-3 (1995), 3 V/m  
prEN 55024-4 (1993) / IEC 801-4 (1988), 1 kV Peak Power Lines  
0,5 kV Signal Lines  
EN 61000-3-2 (1995) / IEC 1000-3-2 (1995), Harmonics  
EN 61000-3-3 (1995) / IEC 1000-3-3 (1994), Flicker

## Supplementary Information:

The product herewith complies with the requirements of the following Directives and carries the CE marking accordingly:  
the EMC Directive 89/336/EEC -the Low Voltage Directive 73/23/EEC (including 93/68EEC)

The Manufacturer listed above declares that this product has been tested and found to comply with the limits of a Class B digital device, pursuant to Part 15 of FCC Rules. These limits are designed to provide reasonable protection against harmful interference in a residential installation. This equipment generates, uses, and can radiate radio frequency energy and, if not installed and used in accordance with the instruction manual, may cause harmful interference to radio communications. However, there is no guarantee that interference will not occur in a particular installation. If this equipment does cause harmful interference to radio or television reception, which can be determined by turning the equipment off and on, the user is encouraged to try to correct the interference by one or more of the following measures:  
a) Reorient or relocate the receiving antenna, b) Increase the separation between the equipment and receiver, c) Connect the equipment into an outlet on a circuit different from that to which the receiver is connected, or d) Consult the dealer or an experienced radio/TV technician for help.

Change or modification of this equipment not expressly approved by Hewlett-Packard could void the user's authority to operate this equipment. Only use the cables, connectors, power cords, and accessories supplied with this equipment or expressly approved by Hewlett-Packard.

**Storage Systems Division March, 1998 Greeley, Colorado, USA**

*Dennis Peery* Date: Feb 3, '98  
Dennis Peery, Quality Manager

## For Regulatory Compliance Information ONLY, contact:

**Australian:** Product Regulations Manager, Hewlett-Packard, Australia Ltd., 31-41 Joseph Street, Blackburn, Victoria 3130, Australia  
**European:** Your local Hewlett-Packard Sales and Service Office or Hewlett-Packard GmbH, Department TRE, Herrenberger Strasse 130, D-71304 Boblingen (FAX:+49-7031-14 3143)  
**USA:** Product Regulations Manager, Hewlett-Packard Company, 700 71st Avenue, Greeley, CO 80634 USA, (Phone: 970-350-5600).

...



# Contents

---

**Preface xxi**

**1. Getting Started 1-1**

- 1.1 Technical Specifications 1-2
  - 1.1.1 Environmental Specifications 1-4
- 1.2 Rackmounting the Autoloader 1-6
  - 1.2.1 Mounting the Autoloader 1-7
  - 1.2.2 Cable Management 1-13
- 1.3 Connecting the Autoloader 1-14
- 1.4 Powering on the System 1-16
- 1.5 Moving or Shipping the Autoloader 1-17
  - 1.5.1 Moving the Autoloader 1-17
  - 1.5.2 Shipping the Autoloader 1-19

**2. Theory of Operation 2-1**

- 2.1 Overview 2-1
  - 2.1.1 Desktop Design 2-1
  - 2.1.2 Rackmount Design 2-1
  - 2.1.3 Autoloader Components 2-2
  - 2.1.4 Reliability 2-4
  - 2.1.5 Environmental Specification 2-4

2.1.6	Stacker and Library Functionality	2-4
2.1.7	Autoloader Firmware	2-4
2.1.8	Autoloader Electronic Connections	2-7
<b>3.</b>	<b>Product Operation and Configuration</b>	<b>3-1</b>
3.1	Chapter Overview	3-1
3.2	Loading/Unloading Tape Cartridges Into the Autoloader	3-2
3.2.1	Inserting and Removing Tapes With Software	3-2
3.2.2	Opening the Door	3-2
3.2.3	Inserting or Removing the Magazine	3-3
3.2.4	Loading Tapes	3-4
3.2.5	Unloading Tapes	3-5
3.3	Autoloader Control Panel	3-6
3.4	Understanding Display Messages	3-7
3.4.1	Tape Status	3-7
3.4.2	Drive/Autoloader Status	3-8
3.5	Top-Level Menu Options	3-9
3.5.1	Password-Protected Functions	3-11
3.5.2	Autoloader Display Menu Tree	3-12
<b>4.</b>	<b>Administration, Diagnostics, and Troubleshooting</b>	<b>4-1</b>
4.1	Chapter Overview	4-1
4.2	Entering the Administration Menu Password	4-2
4.3	Changing the Administration Menu Password	4-3
4.4	Setting or Viewing SCSI IDs	4-4
4.4.1	Setting SCSI IDs	4-4
4.4.2	Viewing SCSI IDs	4-5
4.5	Cleaning the Autoloader Tape Drive	4-6
4.6	Configuring the Autoloader	4-7
4.7	Retrieving Autoloader Information	4-9
4.8	Running an Internal Test	4-10

- 4.9 Drive Cleaning Errors 4-12
- 4.10 Understanding Error Messages 4-13
  - 4.10.1 Field Replaceable Units (FRUs) 4-14
  - 4.10.2 Recovery 4-14
- 4.11 Troubleshooting 4-19
  
- 5. Removal and Replacement 5-1**
  - 5.1 Replacing a Unit 5-2
  - 5.2 Replacing the DLT Drive 5-4
    - 5.2.1 Reassembly 5-6
  - 5.3 Removing Stuck Tapes 5-7
    - 5.3.1 Tape Stuck in Transport 5-7
    - 5.3.2 Tape Stuck Between Magazine and Transport 5-7
    - 5.3.3 Tape Stuck in Internal Slots or Magazine 5-7
    - 5.3.4 Tape Stuck in Drive 5-8
    - 5.3.5 Manually Rewinding Tapes 5-11





# Figures

---

- FIGURE 1-1 Rack Kit Parts 1-6
- FIGURE 1-2 Screw Installation 1-7
- FIGURE 1-3 Customizing the Rack Depth 1-8
- FIGURE 1-4 Shelf Installation 1-9
- FIGURE 1-5 Tightening the Screws 1-10
- FIGURE 1-6 Filler Panel Installation 1-11
- FIGURE 1-7 Securing the Autoloader 1-12
- FIGURE 1-8 Cable Management 1-13
- FIGURE 1-9 Autoloader as the Only Peripheral 1-14
- FIGURE 1-10 Autoloader With Other Peripherals 1-15
- FIGURE 1-11 Unbolting the Autoloader 1-18
- FIGURE 2-1 How Autoloader Firmware Interacts 2-5
- FIGURE 2-2 Interface Overview 2-7
- FIGURE 3-1 Removing the Magazine 3-3
- FIGURE 3-2 Loading Tapes Into the Magazine 3-4
- FIGURE 3-3 Internal Slots 3-5
- FIGURE 3-4 Autoloader Control Panel 3-6
- FIGURE 5-1 Removing the Feet 5-3
- FIGURE 5-2 Removing the Cover 5-3

FIGURE 5-3	Screw Locations	5-4
FIGURE 5-4	Drive Cables	5-5
FIGURE 5-5	Drive Motor Assembly	5-9
FIGURE 5-6	Ejecting the Tape	5-10
FIGURE 5-7	Rewinding a Stuck Tape	5-11

# Tables

---

TABLE 1-1	Physical Specifications of the Autoloader	1-2
TABLE 1-2	Autoloader/Drive Characteristics	1-3
TABLE 1-3	Environmental Specifications	1-4
TABLE 1-4	Description of Rear Panel Connections	1-14
TABLE 1-5	Description of Rear Panel Connections	1-15
TABLE 2-1	Reliability	2-4
TABLE 3-1	Control Panel	3-6
TABLE 3-2	Top-Level Menu Options	3-9
TABLE 3-3	Admin Menu Options	3-11
TABLE 4-1	Default SCSI IDs	4-4
TABLE 4-2	Configuration Options	4-7
TABLE 4-3	Information Logs	4-9
TABLE 4-4	Tests Available From the Control Panel	4-10
TABLE 4-5	Drive Cleaning Troubleshooting	4-12
TABLE 4-6	FRUs (Field Replaceable Units)	4-14
TABLE 4-7	Error Codes	4-14
TABLE 4-8	Troubleshooting Table	4-19
TABLE 5-1	Cable Connectors	5-5
TABLE 5-2	Drive Motor Assembly	5-9

TABLE 5-3 Solenoid Mechanism 5-10

# Preface

---

The *Sun™ StorEdge™ L280 Service Manual* provides installation, operation, and troubleshooting information for the Sun™ StorEdge™ L280 system, which is an eight-cartridge Digital Linear Tape (DLT)™ Autoloader with differential SCSI interface.

These instructions are designed for an experienced system administrator with networking knowledge.

---

## How This Book Is Organized

This manual is divided into the following sections:

**Chapter 1** describes how to install, connect, power on, and move the Autoloader.

**Chapter 2** describes the components of the Autoloader.

**Chapter 3** describes how to operate the control panel.

**Chapter 4** describes how to set administrative options, configure the Autoloader, run internal diagnostic tests, and troubleshoot common problems.

**Chapter 5** describes how to replace the unit and drive, as well as how to remove stuck tapes.

---

# Typographic Conventions

**TABLE P-1** Typographic Conventions

Typeface or Symbol	Meaning	Examples
AaBbCc123	The names of commands, files, and directories; on-screen computer output.	The display reads <code>LOADER READY.</code>
AaBbCc123	Keys on the autoloader control panel.	Enter, Next, Prev, or Cancel
<b>AaBbCc123</b>	What you type when contrasted with on-screen computer output.	<b>su</b> Password:
<i>AaBbCc123</i>	Book titles, new words or terms, words to be emphasized. Command-line variable; replace with a real name or value.	Read Chapter 2 in the <i>User's Guide</i> . These are called <i>class</i> options. You <i>must</i> be root to do this. To delete a file, type <code>rm filename</code> .

---

# Shell Prompts

**TABLE P-2** Shell Prompts

Shell	Prompt
C shell	<i>machine_name%</i>
C shell superuser	<i>machine_name#</i>
Bourne shell and Korn shell	\$
Bourne shell and Korn shell superuser	#

---

## Related Documentation

**TABLE P-3** Related Documentation

<b>Application</b>	<b>Title</b>	<b>Part Number</b>
User Guide	<i>Sun StorEdge L280 User's Guide</i>	805-3957-xx
Installation	<i>Welcome Mat Poster</i>	805-4005-xx

---

## Ordering Sun Documents

SunDocs<sup>SM</sup> is a distribution program for Sun Microsystems technical documentation. Contact SunExpress for easy ordering and quick delivery. You can find a listing of available Sun documentation on the World Wide Web.

**TABLE P-4** SunExpress Contact Information

<b>Country</b>	<b>Telephone</b>	<b>Fax</b>
Belgium	02-720-09-09	02-725-88-50
Canada	1-800-873-7869	1-800-944-0661
France	0800-90-61-57	0800-90-61-58
Germany	01-30-81-61-91	01-30-81-61-92
Holland	06-022-34-45	06-022-34-46
Japan	0120-33-9096	0120-33-9097
Luxembourg	32-2-720-09-09	32-2-725-88-50
Sweden	020-79-57-26	020-79-57-27
Switzerland	0800-55-19-26	0800-55-19-27
United Kingdom	0800-89-88-88	0800-89-88-87
United States	1-800-873-7869	1-800-944-0661

**World Wide Web:** <http://www.sun.com/sunexpress/>

---

---

## Sun Documentation on the Web

The docs.sun.com web site enables you to access Sun technical documentation on the World Wide Web. You can browse the docs.sun.com archive or search for a specific book title or subject at <http://docs.sun.com>.

---

## Support

Information for support, contracts, and local SunService contacts is available at <http://www.sun.com/sunservice>.

---

## Sun Welcomes Your Comments

We are interested in improving our documentation and welcome your comments and suggestions. You can email your comments to us at [smcc-docs@sun.com](mailto:smcc-docs@sun.com). Please include the part number of your document in the subject line of your email.



# Getting Started

---

This chapter explains the following:

- Understanding technical specifications
- Knowing the product components
- Installing the Autoloader
- Connecting the Autoloader
- Powering on the Autoloader
- Moving or shipping the Autoloader

---

# 1.1 Technical Specifications

This section contains information about the following:

- Physical specifications
- Autoloader/Drive characteristics
- Environmental specifications

TABLE 1-1 details the physical specifications of the Autoloader.

**TABLE 1-1** Physical Specifications of the Autoloader

Description	Desktop	Rackmounted
Height	187 mm (7.35 inches)	177 mm (6.97 inches)
Width	226 mm (8.90 inches)	220 mm (8.65 inches)
Depth	559 mm (22 inches)	559 mm (22 inches)
Gross shipping weight	19.3 kg (42.5 lbs.)	17.7 kg (38.9 lbs.)
Interface	SCSI-2 high density wide differential	SCSI-2 high density wide differential

TABLE 1-2 details the performance of the Autoloader and drive.

**TABLE 1-2** Autoloader/Drive Characteristics

<b>Description</b>	<b>Performance</b>
<b>Autoloader characteristics</b>	
Average tape access time	11 seconds
Average tape exchange time	22 seconds
<b>Drive characteristics</b>	
Sustained transfer rate	5 MB/s (10 MB/s with data compression, assuming 2/1 compression)
Peak transfer rate	10 MB/s
Average access time	60 seconds
Tape load time	37 seconds
Tape unload time	17 seconds
Repositioning time	1.3 seconds
Hard error rate	1 x 10 <sup>17</sup> bytes read
Undetected error rate	1 x 10 <sup>27</sup> bytes read
Reliability	200,000 hours MTBF (mean time between failures)

**Note** – The operating system and applications impact data transfer rates.

## 1.1.1 Environmental Specifications

TABLE 1-3 Environmental Specifications

Characteristic	Autoloader
<b>Temperature</b>	
Operating	10° to 40°C
Non-operating	-40° to 66° C
Operating wet-bulb temperature	25°C max
Non-operating wet-bulb temperature	46°C max
Gradient	10°C per hour
<b>Humidity</b>	
Operating	20% to 80% RH
Non-operating	10% to 95% RH
<b>Shock</b>	
Non-operating trapezoidal	28 g/ 253 in/s
<b>Vibration (5 500 Hz)</b>	
Operating	0.21 g rms (random)
Non-operating	2.1 g rms (random)
Non-operating	0.5 g (0 to peak, swept-sine wave)
<b>Product certification</b>	
Safety	UL 1950, CSA 950, TUV IEC 950
Emissions	FCC Class "B" CISPR 22, Class "B"

**TABLE 1-3** Environmental Specifications

Characteristic	Autoloader
Power source	<p>AC power voltage: 100-127V or 200-240V (Auto Ranging)</p> <p>Current Rating: 100-127V, 1.8A, 50/60 HZ , 220-240V, .9A, 50/60 HZ Auto Ranging</p> <p>Power Maximum: 120 Watts Maximum Watts: 100 Watts, 100-127V (60 HZ) Maximum Watts: 90 Watts, 200-240V (50 HZ)</p>
Air quality	<p>Minimal particulate contamination. Avoid areas near frequently-used doors and walkways, stacks of supplies that collect dust, smoke-filled rooms, large or high-speed printers. Do not use filters.</p> <p><b>Caution:</b> Excessive dust and debris can damage DLT tapes and the tape drive.</p>
Adequate clearance	<p>Desktop configuration: free standing:</p> <ul style="list-style-type: none"><li>• Back 6 inches/ 15 cm</li><li>• Front 8 inches/ 20 cm</li><li>• Sides 1 inch/ 2.5 cm</li></ul> <p>Rackmount configuration: requires 5 EIA units in a rack (1 EIA unit = 1.75 inches)</p>

---

## 1.2 Rackmounting the Autoloader

For instructions on connecting desktop units, go to Section 1.3, "Connecting the Autoloader," on page 1-14.

### Tools and Components

Before you begin, make sure you have the following tools and kit components (parts), seen in FIGURE 1-1:

**Tools:**

#2 Phillips screwdriver  
Flat-head screwdriver

**Kit Components:**

- |   |   |
|---|---|
| 1. Instruction poster (Quantity 1)      | 5. 10-32 clipnuts (Quantity 10)         |
| 2. Cable ties (Quantity 4)              | 6. Support bezel (Quantity 1)           |
| 3. M4 x 10-mm pan phillips (Quantity 6) | 7. Filler panel (Quantity 1)            |
| 4. 10-32 pan phillips (Quantity 10)     | 8. Shelf and rail assembly (Quantity 1) |

---

**Note** – The rack kit will contain extra parts.

---

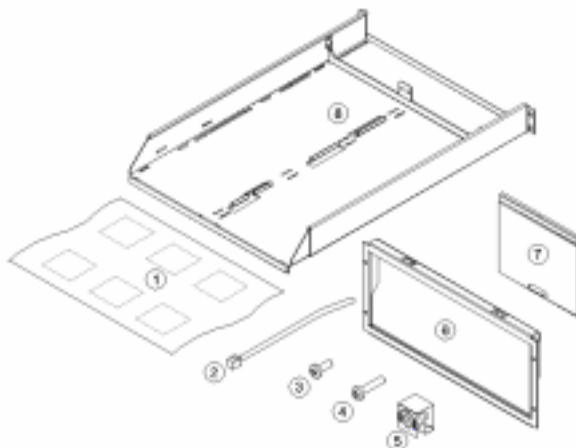

FIGURE 1-1 Rack Kit Parts

## 1.2.1 Mounting the Autoloader

1. Facing the front of the rack and using the *Rackmount Placement Matrix* (part number: 805-6945-xx), hold the bezel in the specified position and install and tighten four 10-32 screws (FIGURE 1-2).

---

**Note** – Your rack structure might look different from the illustrations. If you have a rack that *does not* have threaded screw holes, install the clipnuts in the same position, then install the screws.

---

---

**Note** – Load from bottom to top and load lighter products over heavier ones, as demonstrated in FIGURE 1-2.

---

2. Loosely thread two 10-32 screws into the back rail of the rack. These back bottom screws should be one above the front bottom screws (FIGURE 1-2).

---

**Note** – To ensure a level shelf, count the holes to make sure that the screws are in the same position on the right and left rail.

---

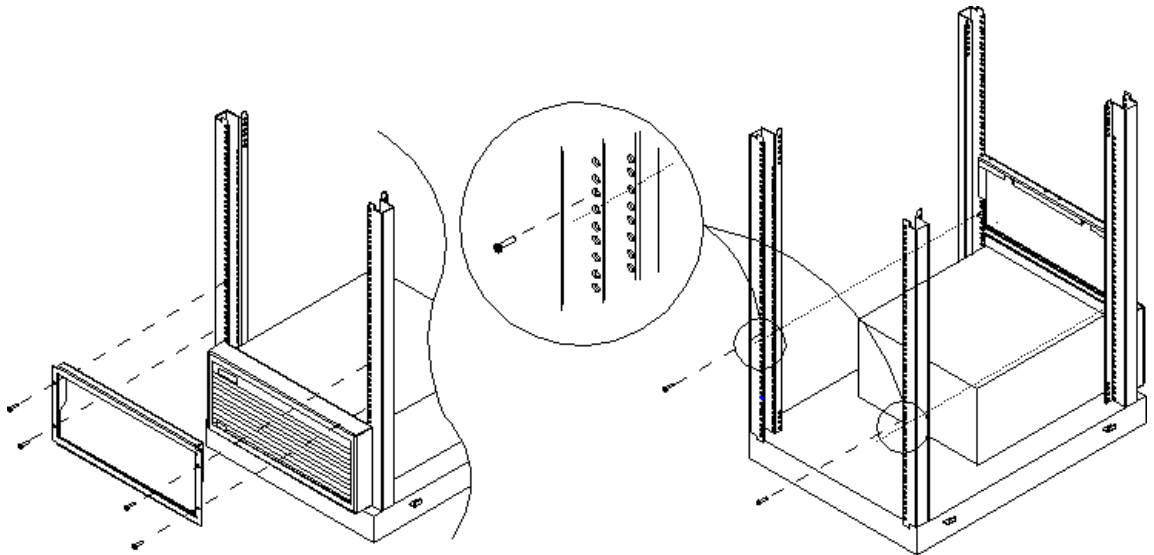

FIGURE 1-2 Screw Installation

3. Before installing the shelf, adjust the shelf depth to fit your rack (FIGURE 1-3). To customize the fit:

---

**Note** – The shelf can be adjusted to fit racks between 25- to 34- inches deep.

---

- a. Remove the four preset screws from the shelf.
  - b. Slide the side rails back until the front rail hole aligns with the 34-inch depth hole (FIGURE 1-3).
  - c. Loosely thread a screw into the 34-inch depth holes, as well as the corresponding holes near the shelf backstop.
- Do not tighten the screws until you install the shelf (FIGURE 1-3).

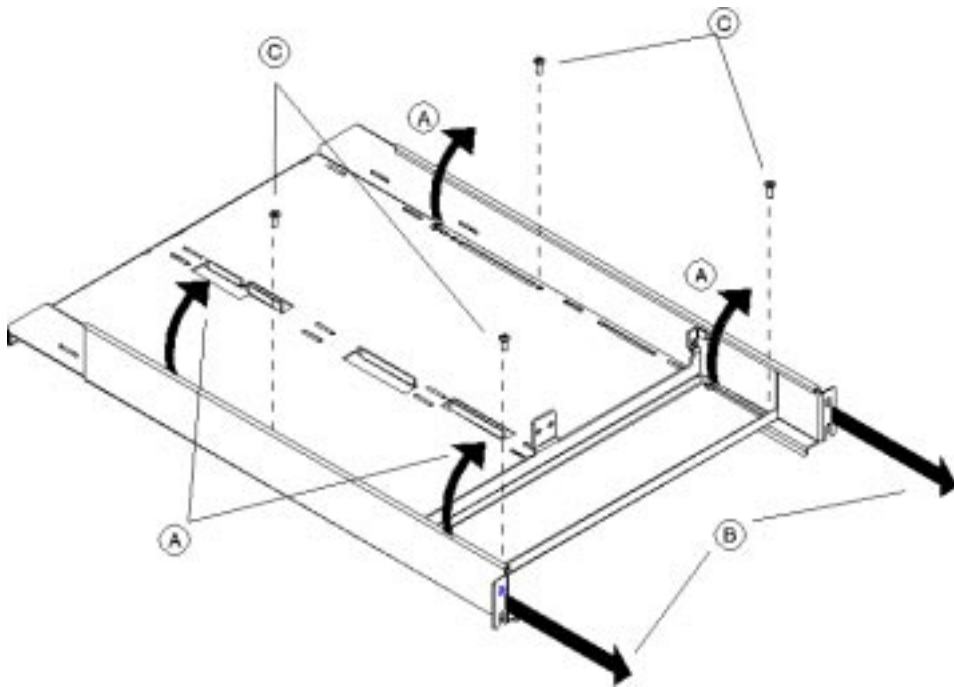
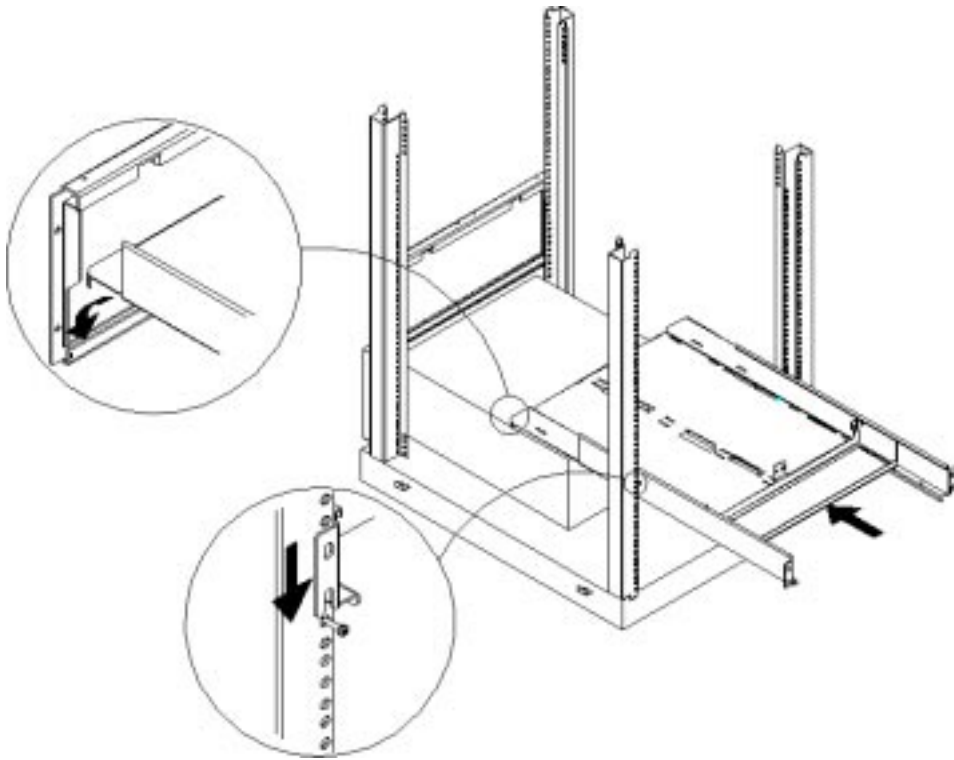

FIGURE 1-3 Customizing the Rack Depth



4. Slide the shelf through the back of the rack until the front lip is over the bezel and the rear portion of the shelf slides over the back screws (FIGURE 1-4).



**FIGURE 1-4** Shelf Installation

---

**Tip** – Have a second person stand at the front of the rack to help guide the front lip of the shelf between the slots on the bezel.

---



---

**Caution** – Ensure that installation in your rack cabinet does not create an unstable condition.

---

5. To secure the shelf to the rack, install and tighten two screws (one on each side) into the upper hole on the back of the shelf (FIGURE 1-5).
  - a. Tighten the four screws on the shelf.
  - b. Tighten the four screws on the back of the rack.

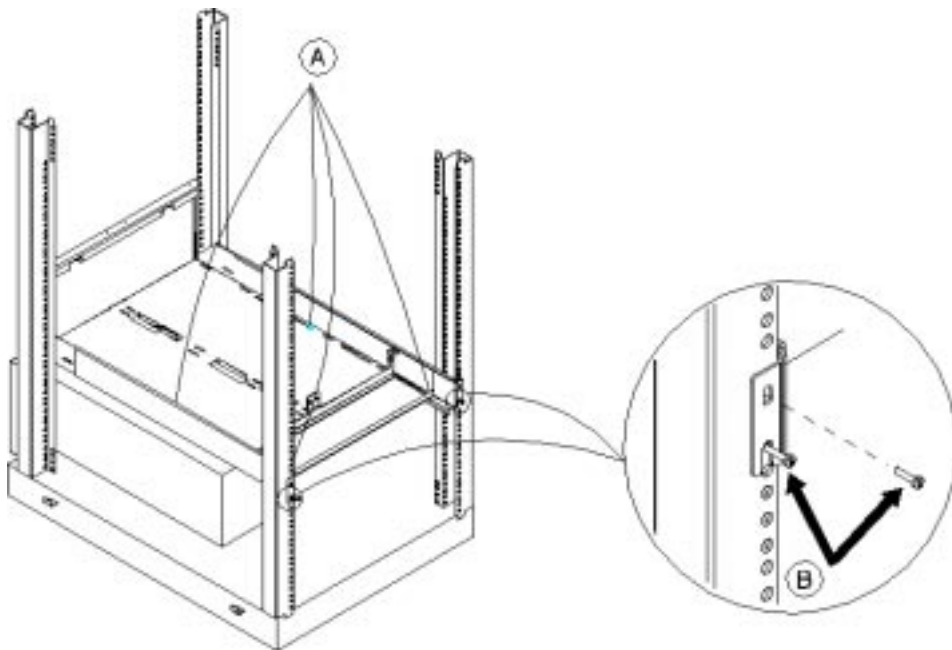
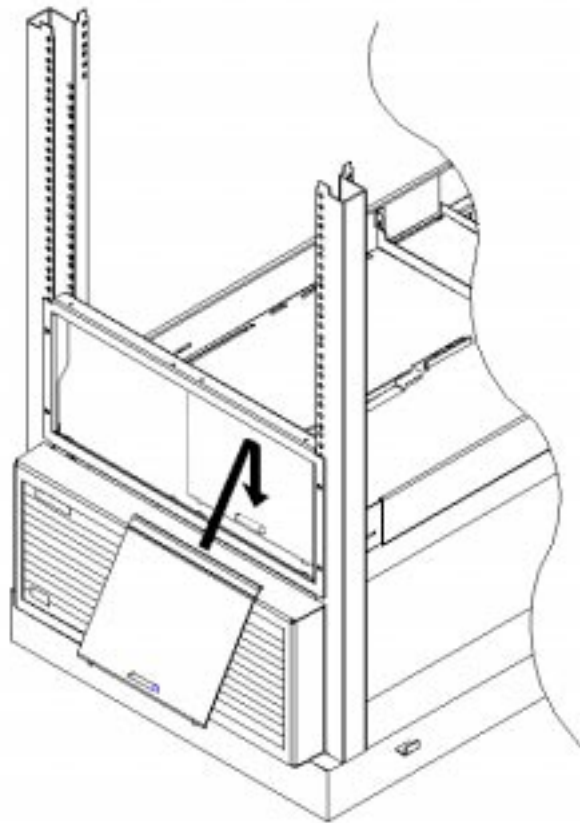

FIGURE 1-5 Tightening the Screws

6. **Decide on the location for the Autoloader. If you are installing one Autoloader, you will insert the filler panel on the opposite side of the support bezel (FIGURE 1-6).**
7. **Align the filler panel to the edge of the support bezel and insert it up into the slot.**  
The tabs on the bottom of the filler panel should fit into the corresponding slots on the shelf. The tab in the top of the filler panel will hold the filler panel in place. If the panel is not correctly installed, it will not load.



**FIGURE 1-6** Filler Panel Installation

8. From the front of the bezel, slide the Autoloader into the shelf until it rests firmly against the support bracket.

---

**Note** – If you are installing a desktop unit into a rack, you will have to remove the cover and feet. See Section 5.1, “Replacing a Unit,” on page 5-2 for the procedure.

---

9. Secure the unit by installing two M4x10-mm screws through the support bracket and into the rear panel (FIGURE 1-7).
10. After connecting the external cables, secure the cables to the side of the rack by following step 4 in Section 1.2.2, “Cable Management,” on page 1-13.

---

**Note** – Save remaining screws for a possible second Autoloader installation.

---

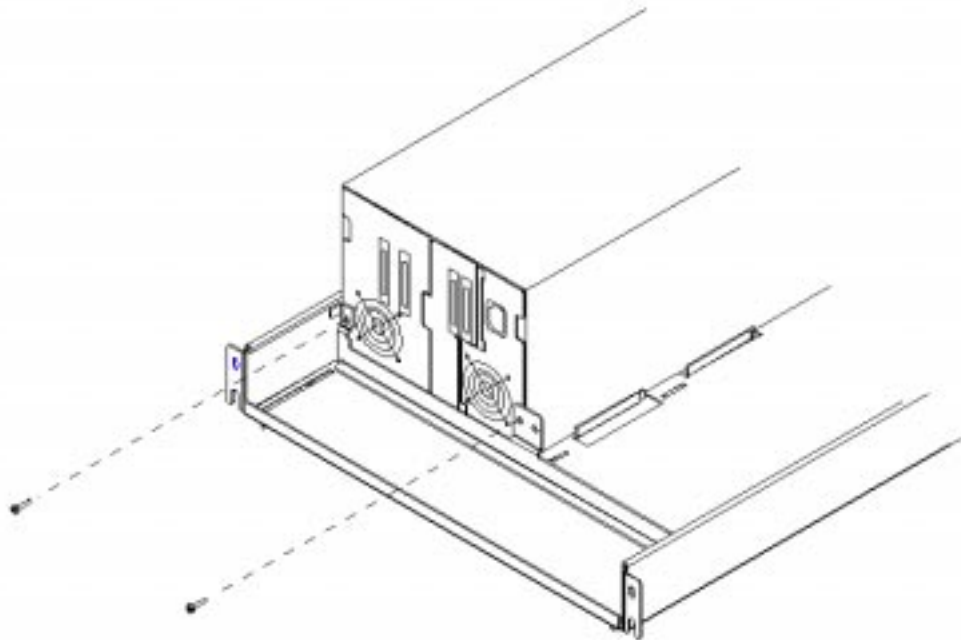

FIGURE 1-7 Securing the Autoloader



---

**Caution** – Be certain that the ambient of the rack cabinet does not exceed the maximum room ambient of 104° F or 40° C.

---

## 1.2.2 Cable Management



---

**Caution** – Ensure that SCSI and power cables are properly routed and secured on rackmounted Autoloaders so that they do not interfere with other moveable rackmounted products. Failure to properly route cables could damage them.

---

1. After connecting the external cables in Section 1.3, "Connecting the Autoloader," on page 1-14, thread a cable tie through the metal rail inside the rack (FIGURE 1-8).
2. Gently pull the cables toward the nearest cable tie to secure them to the rack.
3. Route the cables through the rack so that they do not interfere with other rackmounted products.

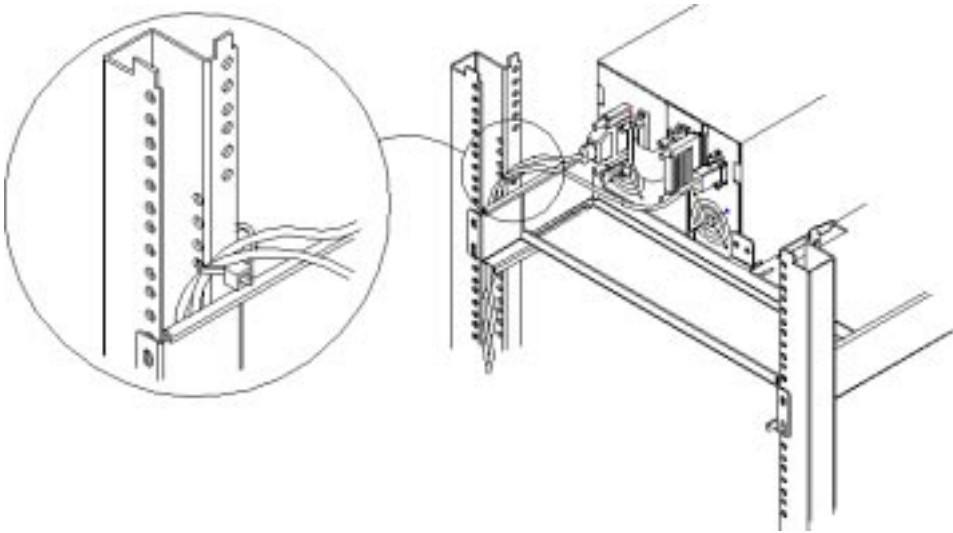

FIGURE 1-8 Cable Management

## 1.3 Connecting the Autoloader



**Caution** – Do not turn on the host system or connect power to the Autoloader until these steps have been completed.

1. **Properly shut down all peripheral devices connected to the host computer.**  
*If the host computer is connected to a network, check with the system administrator before switching off power.*
2. **Shut down the host.**
3. **Connect the long SCSI cable from the Autoloader to the host.**
4. **Connect the SCSI jumper cable to the two inside connectors on the Autoloader.**
5. **Ensure the SCSI terminator is installed as shown in FIGURE 1-9 or FIGURE 1-10.**

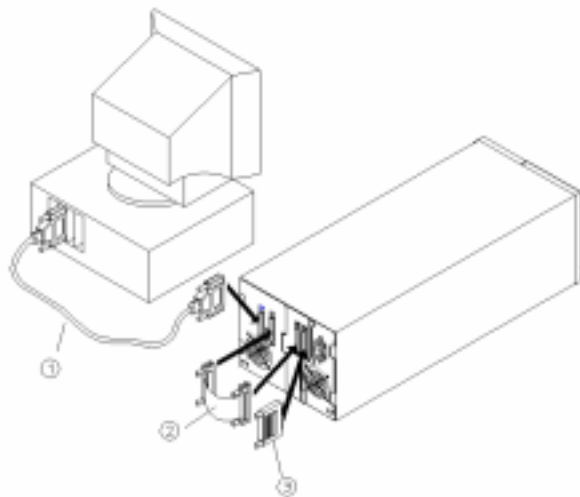

**FIGURE 1-9** Autoloader as the Only Peripheral

**TABLE 1-4** Description of Rear Panel Connections

1	SCSI cable to host SCSI port
2	SCSI jumper cable
3	SCSI terminator (differential)

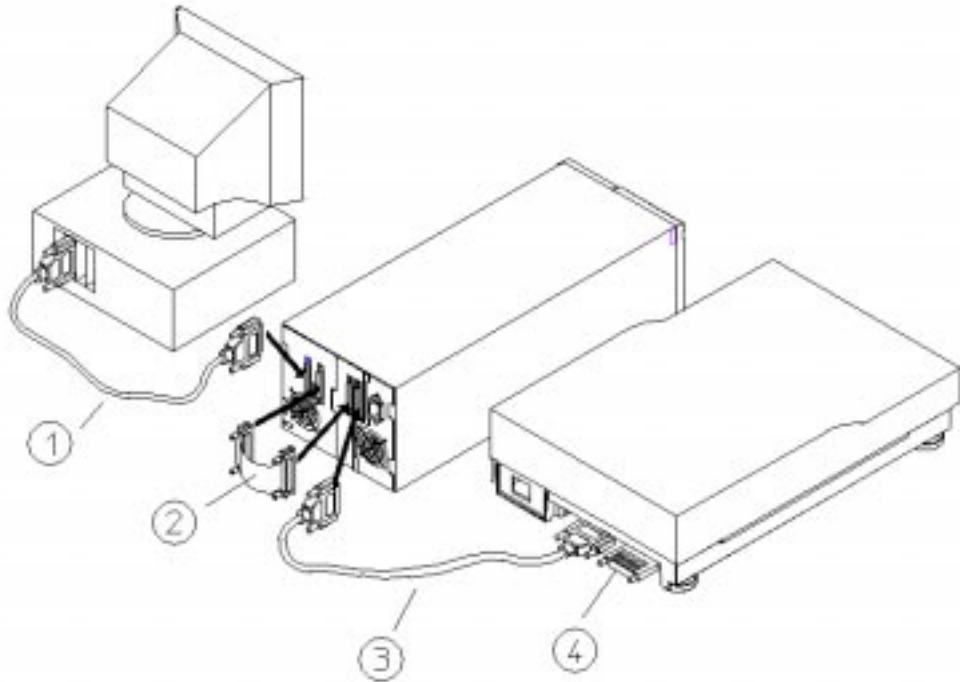

**FIGURE 1-10** Autoloader With Other Peripherals

**TABLE 1-5** Description of Rear Panel Connections

1	SCSI cable to host SCSI port
2	SCSI jumper cable
3	SCSI cable to next device
4	SCSI terminator (differential)

- 6. Make sure the standby (power) switch on the autoloader control panel is switched off, and connect the socket end of the power cord into the power port on the autoloader rear panel.**
- 7. If you are mounting the unit in a rack, secure the cables to the side of the rack (Section 1.2.2, "Cable Management," on page 1-13).**
- 8. To power on the unit, see the instructions in Section 1.4, "Powering on the System," on page 1-16.**

---

## 1.4 Powering on the System



---

**Caution** – To disconnect primary power, pull the power cord from the wall receptacle. The switch on the front of the unit shuts down secondary circuits only.

---



---

**Caution** – Make certain that reliable earth grounding of the rackmounted equipment and the power tap is maintained.

---



---

**Caution** – Be certain that the total current of the rack components does not exceed the current rating of the power tap or outlet receptacle.

---

1. **Connect the power cord into a grounded outlet.**
2. **Using a screwdriver or pencil, turn the power on by pushing the standby (power) switch, located on the bottom of the front access door.**

Initially the messages NOT READY/SELF TEST, NOT READY/INVENTORY CHECK, and NOT READY/CHECK DRIVE will alternately be displayed on the front panel. After the power-on test completes (approximately 30 seconds), the drive status information is displayed in the panel window.

---

**Note** – If you have problems powering on the unit, see TABLE 4-4 on page 4-11.

---

3. **Turn on any other peripherals.**  
Set SCSI IDs as required. See Section 4.4.1, “Setting SCSI IDs,” on page 4-4.
4. **Turn on the host or system.**
5. **Boot system up and load backup software to begin the backup operation.**



---

## 1.5 Moving or Shipping the Autoloader

### 1.5.1 Moving the Autoloader

1. **Verify that a tape is not in the drive.**
  - If using a software application to manage files in the Autoloader, check the software documentation for instructions on removing tapes.
  - If not using a software application, use the UNLOAD top-level menu option.
  - If the drive is loaded with a tape, unload it before moving the Autoloader. Refer to the backup software documentation or to “Opening the Door” on page 3-2..
2. **Switch off power by unplugging the power cord from the back of the unit.**
3. **Shut down the host if necessary.**

---

**Note** – Notify the system administrator before shutting down the host.

---

4. **Remove the power cord and the host SCSI cable from the autoloader rear panel.**
  - If the Autoloader is a desktop unit, lift it onto a cart and wheel it to its new location. Go to step 6.
  - If the Autoloader is rackmounted, follow these steps:

---

**Note** – Keep all external accessories (cables and terminator).

---

- a. **Remove the two screws that secure the back of the Autoloader to the shelf. See FIGURE 1-11 on page 1-18.**
- b. **Remove the filler panel (if necessary), and slide the Autoloader out of the rack.**
- c. **Move the Autoloader to its new destination.**

5. Reinstall the Autoloader into the rack using the rackmount kit instructions in Section 1.2, "Rackmounting the Autoloader," on page 1-6.

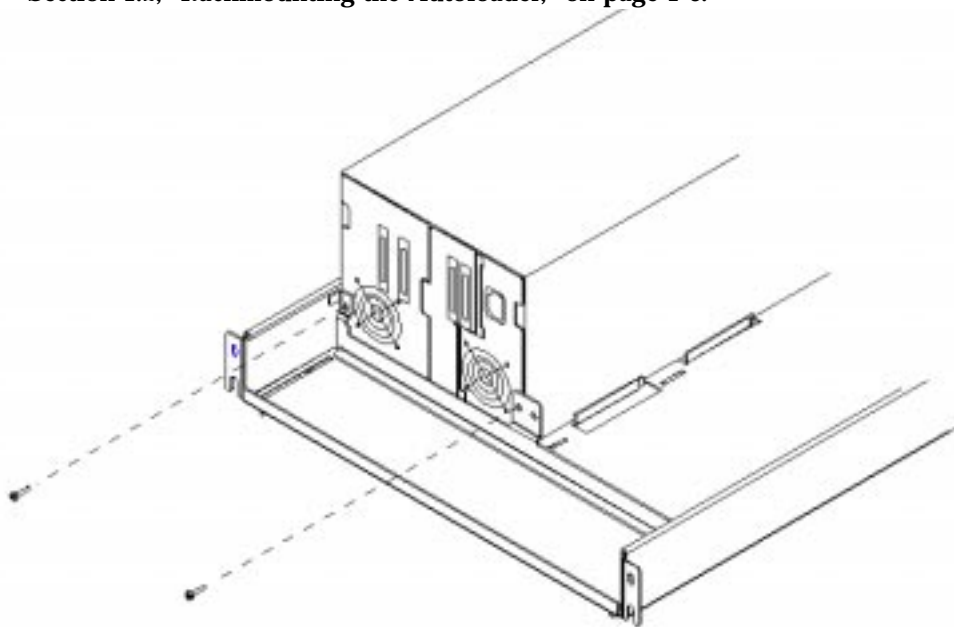

FIGURE 1-11 Unbolting the Autoloader

6. Reconnect the power cord and SCSI cables.
7. Connect the Autoloader to the host. See Section 1.3, "Connecting the Autoloader," on page 1-14.
8. Configure the Autoloader to the host.

---

**Note** – Refer to the host system manuals for configuration information.

---

## 1.5.2 Shipping the Autoloader

1. **Verify that a tape is not in the drive.**
  - If using a software application to manage files in the Autoloader, check the software documentation for instructions on removing tapes.
  - If not using a software application, use the UNLOAD top-level menu option.
  - If the drive is loaded with a tape, unload it before moving the Autoloader. Refer to the backup software documentation or to “Opening the Door” on page 3-2..
2. **Remove all tape cartridges from the magazine and return the magazine to the Autoloader.**
3. **Switch off power by unplugging the power cord from the back of the unit.**
4. **Shut down the host if necessary.**

---

**Note** – Notify the system administrator before shutting down the host.

---

5. **Remove the power cord and the host SCSI cable from the rear panel.**
    - If the Autoloader is a desktop unit, go to step 6.
    - If the Autoloader is rackmounted, follow these steps:
- 
- a. **Remove the two screws in the back of the Autoloader.**
  - b. **Remove the filler panel (if necessary), and slide the Autoloader out of the rack.**
6. **Repackage the Autoloader in the original packing materials. Contact a support representative if packing materials are needed.**

---

**Caution** – The Autoloader can be seriously damaged if it is not shipped using appropriate shipping materials.

---



# Theory of Operation

---

---

## 2.1 Overview

The DLT Autoloader is optimized for automated backup of servers or systems requiring data backups up to 280 Gbytes native capacity or 560 Gbytes compressed. The Autoloader comes with one DLT 7000 drive with a differential SCSI interface and eight storage slots for tape cartridges. Six of these slots are in a removable magazine and two are in fixed slots to the rear of the transport, which are accessible by removing the magazine.

### 2.1.1 Desktop Design

The desktop unit is 7.75 inches high x 8.87 inches wide x 22.0 inches deep, and includes a cosmetic enclosure that covers the top and sides. There are also four black plastic feet that are screwed on with flat-head screws. The top of the unit has a viewing window (3.0 inches x 4.25 inches), which also exists in the rackmount version.

### 2.1.2 Rackmount Design

The autoloader is rackmountable. The rackmount design requires 5 Electronic Industries Association (EIA) standard units and is designed so that two Autoloaders can be positioned side-by-side. The rack provides incremental rack configuration flexibility, more drives/volume and more tapes/volume.

## 2.1.3 Autoloader Components

### 2.1.3.1 Door

The door opens to allow access to the magazine. This door is locked by a solenoid during normal operation and unlocked either from a front panel menu selection or by pressing the Cancel button from three to five seconds. The door can also be opened when the unit is powered down. The handle is removable by two screws.

### 2.1.3.2 Shelf

The shelf supports the Autoloader when it is rackmounted and comes with the rackmount kit. The shelf provides incremental rack configuration flexibility.

### 2.1.3.3 Bezel

The bezel holds up the front of the shelf when the Autoloader is rackmounted. The bezel comes with the rackmount kit.

### 2.1.3.4 Cosmetic Covering (Desktop Only)

The cosmetic covering protects the Autoloader during operation and shipment and may be removed for rackmounting.

### 2.1.3.5 Standby (Power) Switch

The standby (power) switch is recessed behind a hole in the bottom left-hand corner of the door. This switch can be accessed through the hole with a pen or pencil or when the door is open. When open, a sheetmetal guard by the switch prevents accidental switching during magazine insertion or removal. This switch turns off power to the drive, fans, autoloader controller board, and display. See Section 2.1.8, "Autoloader Electronic Connections," on page 2-7 for more information.



---

**Caution** – Power is not turned off to the transport controller and the transport.

---

### 2.1.3.6 Removable Magazine

The magazine holds six tapes that are held in place with a latching mechanism. Pushing the tape in causes the mechanism to latch and lock the tape in place. A second push on the tape releases the tape. The magazine also has a handle for carrying. The tape slots are numbered from left to right (1-6). There are two spaces on the magazine for labels: one 10 mm x 49 mm (.4 inch x 1.9 inch) on the front of the magazine and one on the handle that can hold an adhesive-backed label 56 mm x 21 mm (2.2 inch x .8 inch).

### 2.1.3.7 Front Panel Display

The front panel display is a backlit LCD display with two lines of 16 characters per line. The panel has four buttons labeled Next, Previous, Cancel, and Enter, see Section 3.3, “Autoloader Control Panel,” on page 3-6..

There is a status LED in the center of the group of four buttons that indicates the following:

- Steady Green: Power On
- Flashing Green: Drive activity
- Amber: Device Failed (see Section 4.10, “Understanding Error Messages,” on page 4-13))

The two-line display enables the current menu item to be shown while the user scrolls through the next level of menu choices. See Section 3.5.2, “Autoloader Display Menu Tree,” on page 3-12..

### 2.1.3.8 Back Panel

The back panel has the following features:

- Four fast/wide SCSI connectors, 68-pin high density: two for the drive and two for the autoloader controller. A 4-inch external SCSI jumper cable is included to connect the drive and the controller on a single line.
- One power connector to a power supply that enables 100V-240V operation without the need for voltage selection.
- Two fans: one to cool the drive and one to cool the power supply.
- Three subassemblies:
  - The drive with its alignment bracket, fan, and SCSI cable connections
  - The SCSI Interface board with its rear faceplate and SCSI connectors
  - The power supply

## 2.1.4 Reliability

TABLE 2-1 Reliability

Part	Probable Life Span
Autoloader MSBF	200,000 Swaps
Magazine life	45,000 Swaps
Tape cartridge	10,000 Swaps
Drive	50,000 Load/Unload Cycles

## 2.1.5 Environmental Specification

Temperature and humidity is limited by the media specification of 10°C-40°C operating and 20%-80% noncondensing. Humidity and temperature is also limited to 26°C wet bulb temperature. See Section 1.1.1, “Environmental Specifications,” on page 1-4 for more information.

## 2.1.6 Stacker and Library Functionality

The Autoloader has three modes of operation. See Section 3.5, “Top Level Menu Options,” on page 3-9 for more information.

- Autodetect mode: Defaults to Stacker mode until the Autoloader receives a changer command, which changes it to Random mode until it is power cycled.
- Stacker mode: Loads each tape sequentially after each drive unload request.
- Random mode: Allows random access to tapes per command to the Autoloader.

## 2.1.7 Autoloader Firmware

The autoloader firmware consists of the following five modules (FIGURE 2-1 on page 2-5):

- Interface manager
- Front panel manager
- Diagnostics manager
- Motion manager
- Transport motion controller



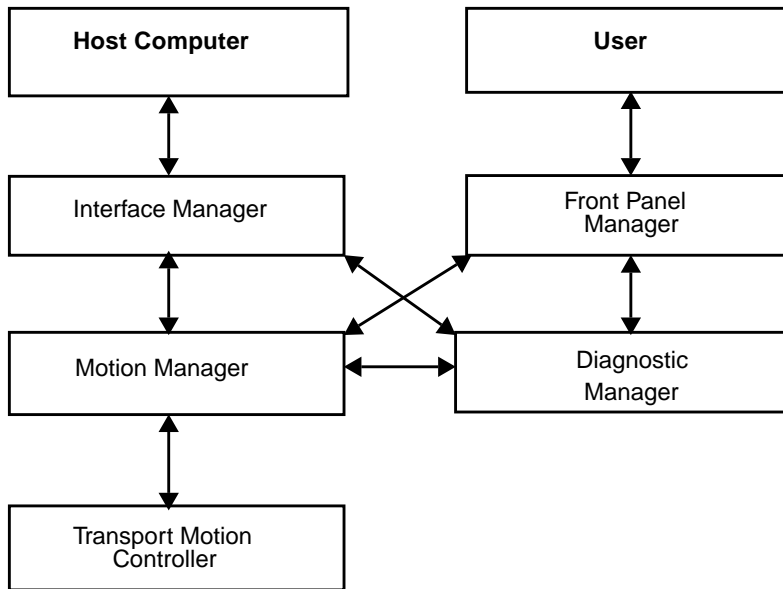

**FIGURE 2-1** How Autoloader Firmware Interacts

### 2.1.7.1 Interface Manager

The interface manager is responsible for handling all commands sent from a host computer to the Autoloader. The commands are sent using a differential SCSI interface, which conforms to the SCSI-2 specifications.

---

**Note** – The interface manager is disabled when the product is in Stacker mode.

---

### 2.1.7.2 Front Panel Manager

The front panel is the user’s direct interface to the Autoloader. Most of the functions that can be done through the SCSI interface can be accessed manually through the front panel including full load/unload capability. See Section 3.5.2, “Autoloader Display Menu Tree,” on page 3-12. The front panel interface is also described in more detail in Chapter 3, “Product Operation and Configuration.”

### 2.1.7.3 Diagnostic Manager

The diagnostic manager controls all self testing of the library. Most of its functionality is executed automatically at power-up without user interaction. The user can access some of the functionality of the diagnostic manager through the front panel or the SCSI send diagnostic command. See Section 4.8, “Running an Internal Test,” on page 4-10.

### 2.1.7.4 Motion Manager

The motion manager communicates with the drive as necessary and receives all motion command requests, breaking them into move steps. The motion manager then issues commands to the transport motor controller. The motion manager is also responsible for any error recovery attempts and reports the results to the front panel, diagnostic, and interface managers.

### 2.1.7.5 Transport Motion Controller

The transport motion controller controls the loader, which performs individual move steps.

## 2.1.8 Autoloader Electronic Connections

FIGURE 2-2 shows the electronic (interface) connections.

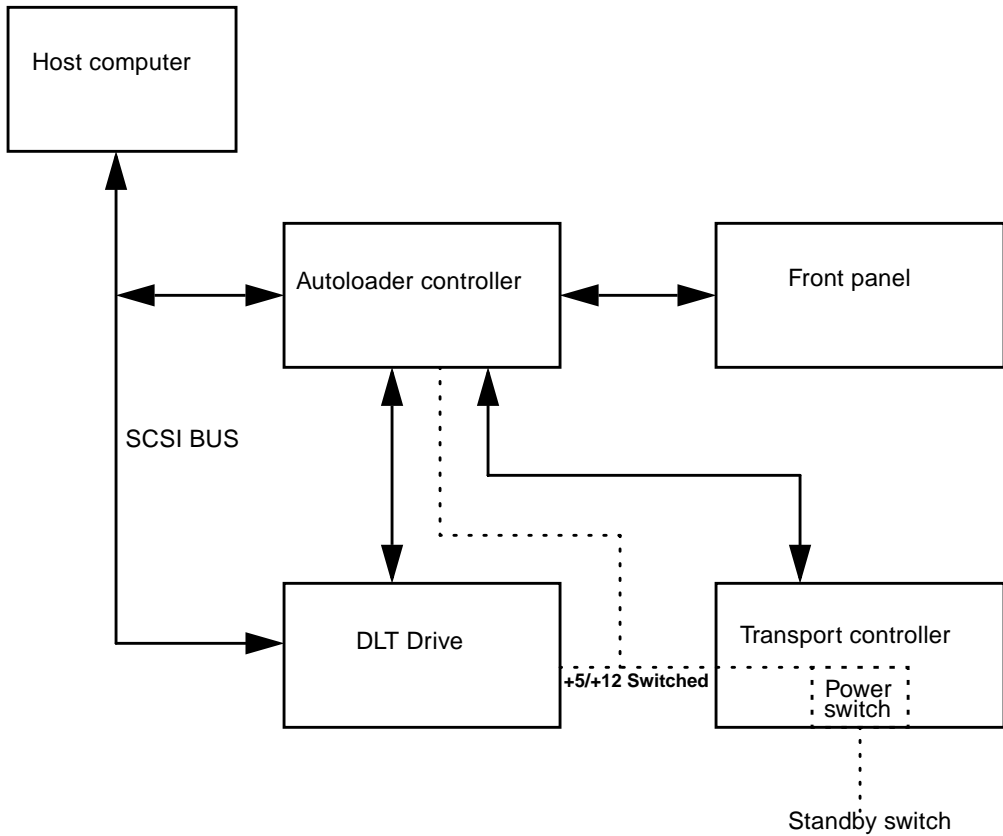

FIGURE 2-2 Interface Overview



# Product Operation and Configuration

---

## 3.1 Chapter Overview

This chapter explains how to:

- Load and remove tapes
- Operate the control panel
- Interpret display window messages
- Understand top-level menu options

---

## 3.2 Loading/Unloading Tape Cartridges Into the Autoloader

### 3.2.1 Inserting and Removing Tapes With Software

If you are using a software application to manage files in the Autoloader, check the software documentation for instructions on inserting and removing tape cartridges.

### 3.2.2 Opening the Door

1. **Press and hold the Cancel button for three to five seconds.**
2. **Gently pull on the door handle to open.**

---

**Note** – This method of opening the door is most effective when the drive is empty and the Autoloader is idle (see Section 3.4, "Understanding Display Messages," on page 3-7). If the Autoloader is performing a function, it will abort the function, then release the door.

---

#### 3.2.2.1 Alternative Door Open Method

1. **Press the Next button until RELEASE DOOR is displayed in the front panel.**
2. **Press Enter.**
3. **If the drive is empty, the door will release.**
  - If a tape is loaded in the drive, EMPTY DRIVE NO is displayed. If the library is controlled with the host software, press Enter or Cancel to abort. Use the host software to unload the drive.
  - Otherwise, press the Next or Prev button until EMPTY DRIVE YES is displayed, and then press Enter.

UNLOADING DRIVE will be displayed for up to two minutes, followed by DOOR RELEASED.

4. **Gently pull on the door handle to open.**

### 3.2.3 Inserting or Removing the Magazine

1. Swing the handle forward.
2. Pull the magazine straight out (FIGURE 3-1, part no. F370-3422-01).

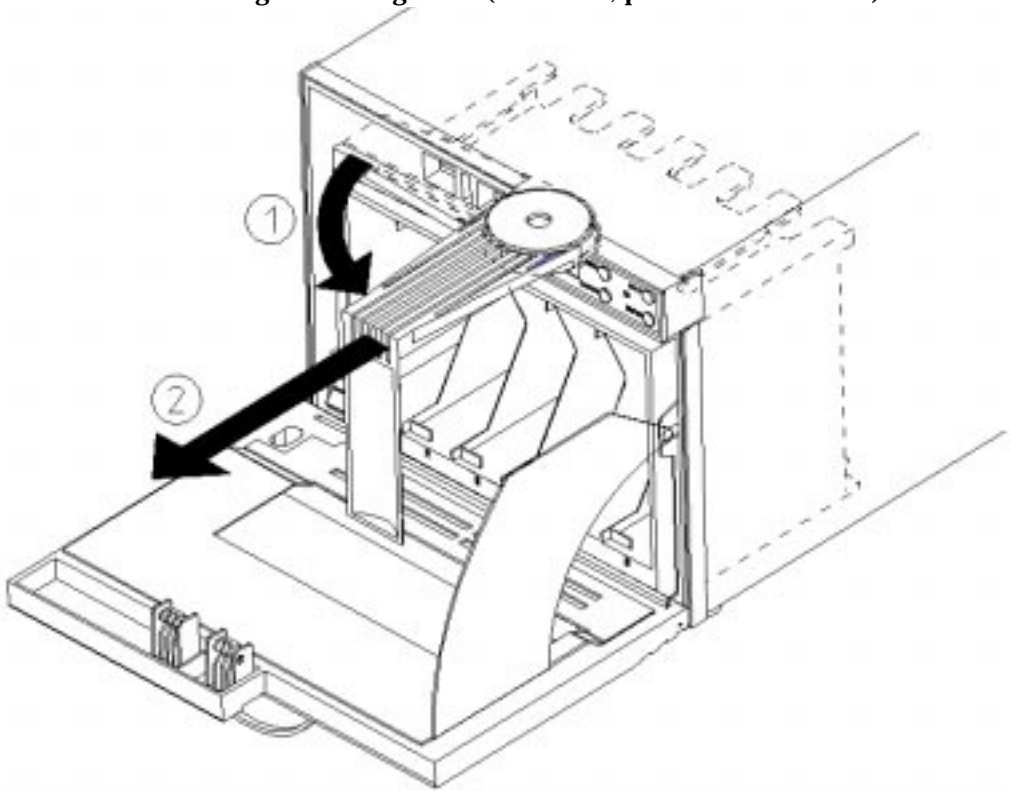

FIGURE 3-1 Removing the Magazine

## 3.2.4 Loading Tapes

The Autoloader has two internal storage slots behind the magazine (slot numbers 7 and 8) and six slots in the removable magazine (slot numbers 1-6).

1. **With the write-protect switch facing out and at the top, load tapes into the magazine by pushing the tape in and holding it until it “clicks.”**

A metal tab will release and lock it into place (FIGURE 3-2).

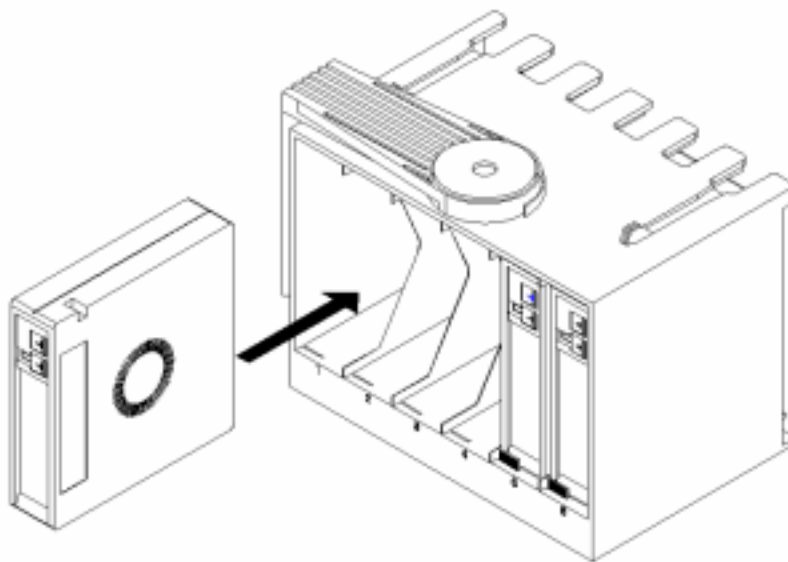

FIGURE 3-2 Loading Tapes Into the Magazine



---

**Caution** – Since this is a static-sensitive area, touch the sheet-metal panel on the left side of the unit for electrostatic discharge. Take care not to touch internal electronics.

---

---

**Note** – If the metal tab is stuck in the “Up” position, place the corner of the tape on the tab, and slide the tape into the slot. The latching mechanism will not click since the tab is already engaged. When tapes are “locked” into the magazine, the tapes will not fall out if the magazine is turned.

---



2. With the write-protect switch facing out of the Autoloader and at the top, load internal slots by pushing the tape in until it “clicks.” The magazine must be removed to load the internal slots (FIGURE 3-3).

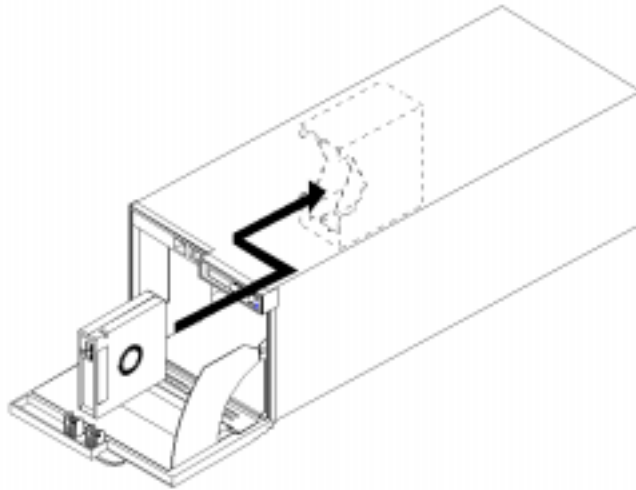

FIGURE 3-3 Internal Slots

3. With the magazine handle facing out the front of the Autoloader, slide the magazine into the Autoloader until it “clicks” into place (FIGURE 3-1 on page 3-3).
4. Swing the handle to the left to store.
5. Gently shut the access door.

---

**Note** – The `INVENTORY CHECK` utility runs when the access door closes so that an inventory of storage slot locations can be stored into the autoloader memory. This process takes approximately thirty seconds. The inventory check will not run if the door is not completely shut.

---

## 3.2.5 Unloading Tapes

1. Remove the magazine by following the steps under “Opening the Door” on page 3-2 and “Inserting or Removing the Magazine” on page 3-3.
2. Push the tape in until it “clicks.” The tape will partially eject.

## 3.3 Autoloader Control Panel

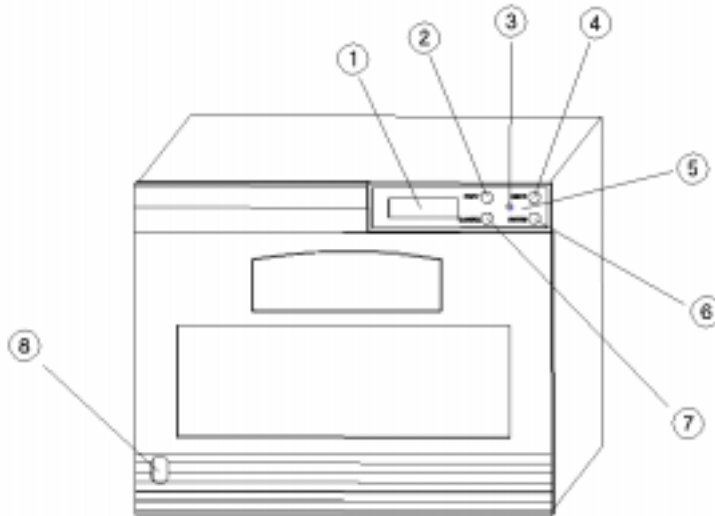

FIGURE 3-4 Autoloader Control Panel

TABLE 3-1 Control Panel

1	Two line, 16-Character Display	Displays the current operation or drive status. An asterisk (*) indicates a submenu for that task. Press Enter on the control panel to access that menu.
2	Prev key	Scrolls the display choice backward by one.
3	Activity Light	Indicates the following: <ul style="list-style-type: none"> <li>• Steady green: Power is on.</li> <li>• Flashing green: A tape cartridge is being accessed.</li> <li>• Amber: Error. If this occurs, see TABLE 4-7 on page 4-14.</li> </ul>
4	Next key	Scrolls the display choice forward by one.
5	Control panel keys	Used to navigate through the front panel menus.
6	Enter key	Selects the option currently displayed.

**TABLE 3-1** Control Panel (*Continued*)

7	Cancel key	Cancels the current selection or brings you from the current menu/function to the previous one. Hold three to five seconds to release the door.
8	Power (standby) switch	Located in the bottom-corner of the front access door and puts the unit's power in Standby mode.

## 3.4 Understanding Display Messages

The front panel window is a two-line display with 16 characters per line that shows the status of the Autoloader or the current menu title and option.

### 3.4.1 Tape Status

The following example shows the control panel display when the Autoloader is in the ready state.

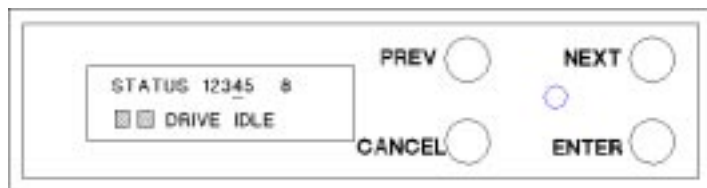

The numbers on the top line show that slots 1, 2, 3, 5, and 8 have tapes in them, slots 6 and 7 are empty, and tape 4 is in the drive.

- A blinking number indicates that the tape is being moved from a slot or the drive.
- If a tape is in the drive, the number remains lit and is underlined (tape 4 in the example).
- If the slots or the Autoloader is empty, the top line reads `STATUS EMPTY`. On the bottom line, the display will read `LOADER READY` or a drive activity message and can include one of these indicators (represented by the shaded boxes above):
  - `C` displays if the drive needs cleaning
  - `WP` displays if a tape is write protected

---

**Note** – In a menu option (other than a test menu), the Autoloader defaults to the drive status display when there has been no user interaction for three minutes.

---

## 3.4.2 Drive/Autoloader Status

The top display line normally shows the slot status or the current menu title.

The bottom display line shows the drive/loader activity, unless a front panel menu has been selected. See Section 3.5, "Top-Level Menu Options," on page 3-9.

The status of the drive and Autoloader is indicated by the following:

- LOADER READY
- LOADER ACTIVE
- DRIVE IDLE
- CLEANING
- WRITING
- READING
- REWINDING
- SEEKING
- ERASING
- LOADING
- UNLOADING
- NO DRIVE

## 3.5 Top-Level Menu Options

The menu structure is divided between standard access and password-protected functions.

- **To move through the menu, use the control panel keys. If a menu selection is flashing, press Enter to select that option.**

The top-level menu contains the following functions. Press Prev or Next while the Autoloader is in the ready state to view these options:

**TABLE 3-2** Top-Level Menu Options

Option	Function
RELEASE DOOR *	Unlocks the access door. See "Opening the Door" on page 3-2.
LOAD TAPE *	Moves a tape from a slot to the drive. <ul style="list-style-type: none"><li>• The second line displays FROM SLOT with the slot number.</li><li>• Press Next until the desired slot number displays. Press Enter to select.</li></ul> The first full slot is the default slot. If one slot is loaded, only this slot can be selected.
UNLOAD TAPE *	Unload a tape from the drive to the slot it came from.
ADMIN *	All functions under this menu option are password protected. See Section 3.5.1, "Password-Protected Functions," on page 3-11.
OPERATING MODE *	There are three operating modes, which are described below and in more detail on the following page: <ul style="list-style-type: none"><li>• AUTODETECT MODE Operates as if in stacker mode until the Autoloader receives a changer command. It then operates as if in random mode until power cycled.</li><li>• STACKER MODE Loads each tape sequentially after each drive unload request.</li><li>• RANDOM MODE Allows random access to tapes.</li></ul>

\* Indicates there are multiple selections for that option. Refer to Section 3.5.2, "Autoloader Display Menu Tree," on page 3-12 for the additional selections.

Autodetect	<p>This is the default mode for the Autoloader. The Autoloader operates as if in Stacker mode until it receives a SCSI changer command. After this command, the Autoloader operates as if in Random mode. The drive defaults to ID 0 and the controller to ID 1. Changer commands are: INITIALIZE ELEMENT STATUS, READ ELEMENT STATUS, POSITION TO ELEMENT, MOVE MEDIA, and EXCHANGE MEDIA.</p>
Stacker	<p><i>Mode:</i> When in Stacker mode, the autoloader controller will not use an ID and is removed from the SCSI bus. Only the drive is available at ID 0. In this mode, the jumper cable can be removed from the back of the Autoloader, but leaving the cable connected will not impact the system. <i>Note:</i> Move the terminator to the drive connector side.</p> <p><i>Operation:</i> An autoloader option is available under the CONFIG menu. If selected, the first available tape loads into an empty drive at power up. By default, autoloader is off so that the user must use the front-panel LOAD command to load tape cartridges. When the host issues a SCSI unload command, the Autoloader removes and inserts tape cartridges until the last piece has been unloaded. If the Circular mode option has been selected in CONFIG, the Autoloader will reload the first tape cartridge. If Circular is disabled and the last tape cartridge has been unloaded, the Autoloader stops operating until the user loads more tape cartridges. If the Autoloader encounters a cleaning cartridge during the cycle, it will be loaded into the drive as normal, but will be automatically unloaded after the cleaning cycle. If the user indicates which slot contains the cleaning cartridge via the clean drive menu, the Autoloader will skip that slot.</p>
Random	<p><i>Mode:</i> In Random mode, the drive and the autoloader controller are assigned SCSI IDs. The drive defaults to an ID of 0 and the autoloader controller to an ID of 1. All stacker features are disabled after selecting random mode. Tape cartridges can only be moved by using host SCSI commands to the Autoloader or by using the LOAD/UNLOAD front panel menu.</p> <p><i>Operation:</i> The SCSI interface for the Autoloader in Random mode conforms to the SCSI-2 command specification for tape changer devices.</p>

## 3.5.1 Password-Protected Functions

All ADMIN \* functions are password protected.

### 1. Before accessing the following options, enter the password.

A default password of 000-000-000 is set at the factory. Change this password when first using the Autoloader.

**TABLE 3-3** Admin Menu Options

Option	Function
INFO *	Retrieves performance information stored in the Autoloader.
CLEAN DRIVE *	Enables the user to clean the drive.
SCSI IDs *	Sets the SCSI addresses for the autoloader controller and the drive.
CONFIG *	Customizes the Autoloader's functions. See TABLE 4-2 on page 4-7.
UPDATE DRIVE FW *	Enables the user to update the firmware in the drive.
TEST *	Runs internal autoloader tests (Section 4.8, "Running an Internal Test," on page 4-10).
OVERRIDE DOOR	Emergency door release that does not check the internal state of the Autoloader.

### 2. When a changeable menu selection is flashing, press Enter to select the option, or press the Prev or Next button to display other available options.

### 3. Press Enter to select the flashing item.

Section 3.5.2, "Autoloader Display Menu Tree," on page 3-12 shows the autoloader menu options available throughout the control panel.

To select the functions listed below the shaded boxes:

- a. Press Enter when that option is displayed.
- b. Press the Prev or Next button to scroll through the list.
- c. To perform the displayed operation, press Enter.

## 3.5.2 Autoloader Display Menu Tree

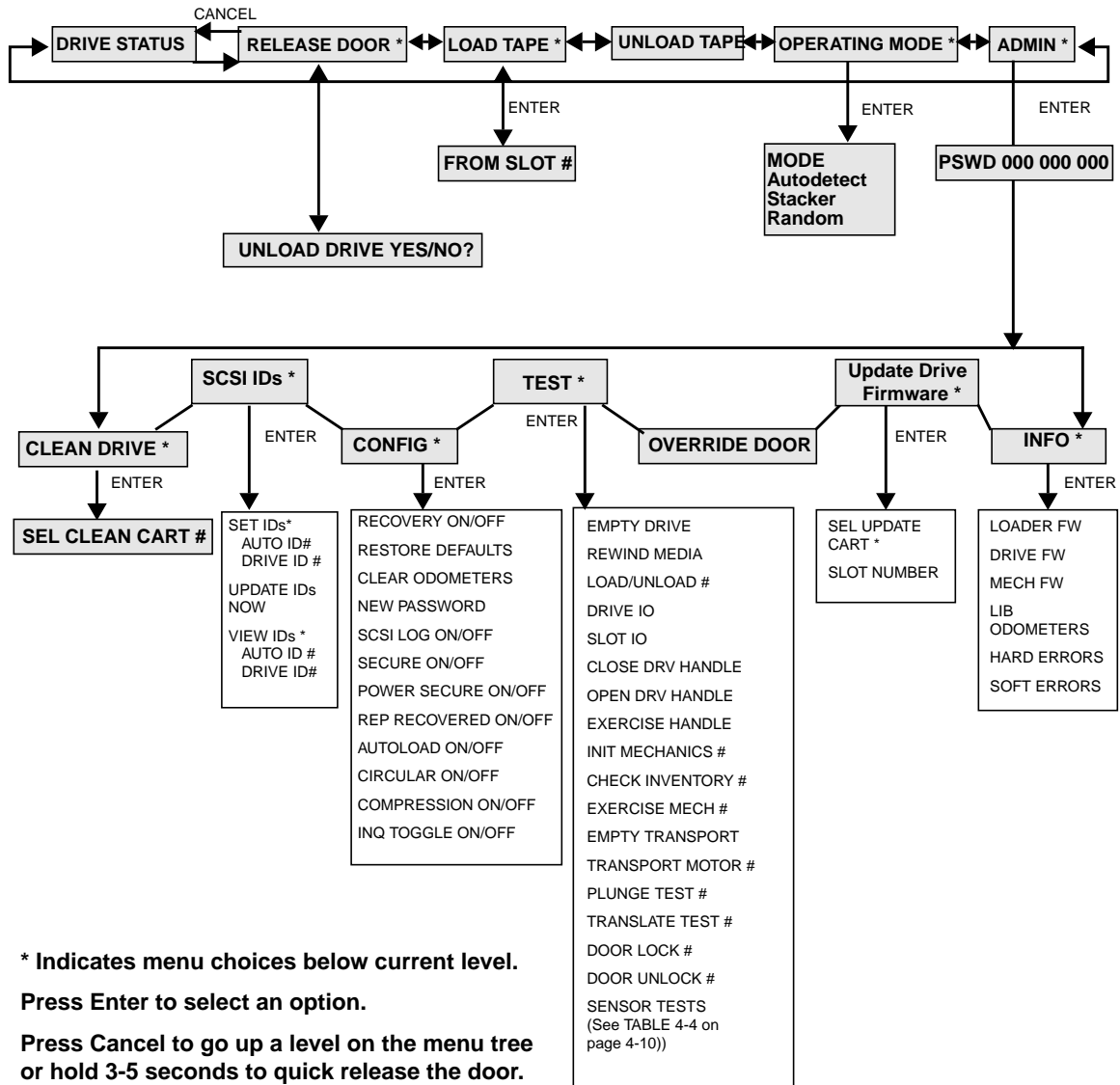



# Administration, Diagnostics, and Troubleshooting

---

## 4.1 Chapter Overview

This chapter describes how to:

- Change an administration menu password
- View and set SCSI IDs
- Clean the tape drive
- Configure the Autoloader
- Retrieve Autoloader information
- Run internal tests
- Interpret drive cleaning errors
- Interpret error codes
- Troubleshoot

---

## 4.2 Entering the Administration Menu Password

A numeric password is required to access functions within the ADMIN \* menu. A default password of 000-000-000 is set at the factory, which can be used when the Autoloader is powered on for the first time. Change the password if the Autoloader is in an insecure location.

---

**Tip** – If the user cannot remember the password, try using the default password.

---

- 1. Starting at the top-level menu, press the Next button until ADMIN \* is in the display window.**
- 2. Press Enter.**  
The password displays; the first set of digits flashes.
- 3. Press Enter to accept the first set of flashing digits or the Next/Prev button to change the values.**
- 4. Press Enter to accept the second set of flashing digits or Next/Prev to change the values.**
- 5. Press Enter to accept the last set of flashing digits or Next/Prev to change the values.**  
INFO \* displays.
- 6. Press the Prev or Next button until the desired function displays, then press Enter.**

---

## 4.3 Changing the Administration Menu Password

---

**Tip** – Change the administration password before connecting to the host to prevent power cycling during configuration.

---

1. Complete steps 1 through 6 in Section 4.2, “Entering the Administration Menu Password” on page 4-2.
2. Press the Next button until `CONFIG *` displays, and press Enter.
3. Press the Next or Prev button until `NEW PASSWORD` displays, and press Enter.  
`NEW 000 000 000` displays, and the first set of zeros flashes.
4. Press the Next or Prev button until the new number for the first part of the password displays, then press Enter.  
The second set of zeros flashes.
5. Press the Next or Prev button until the new number for the second part of the password displays, then press Enter.  
The last set of zeros flashes.
6. Press the Next or Prev button until the new number you wish to assign to the third part of the password displays, then press Enter.  
`PASSWORD CHANGED` displays, which indicates that the password has been saved to non-volatile RAM.
7. Press Cancel three times to return to the ready state.



---

**Caution** – Consult the system administrator before power cycling.

---

---

**Note** – After changing the password, you can save the new password to flash ROM by power cycling the Autoloader, which enables the password to be recovered if the Autoloader is powered off for more than ten days. If this step is not completed and the Autoloader is turned off for more than 10 days, the password changes may be lost.

---

## 4.4 Setting or Viewing SCSI IDs

- Press the Next button to enter the following:

```
ADMIN * / PSWD ### ### ### / SCSI IDs *
```

**Note** – Before setting SCSI IDs, check to see which IDs are available.

When you choose SCSI IDs, you have two options:

- SET IDs \* assigns a SCSI ID to the drive and a SCSI ID to the autoloader controller.
- VIEW IDs \* displays the drive and autoloader controller settings.

TABLE 4-1 shows the default settings.

TABLE 4-1 Default SCSI IDs

Device	SCSI ID
Autoloader ID	1
Drive ID	0

### 4.4.1 Setting SCSI IDs

To set SCSI IDs, press the Next button to enter the following:

```
ADMIN * / PSWD ### ### ### / SCSI IDs */ SET IDs *
```

1. **When SET IDs \* is displayed, press Enter.**
  - AUTOLOADER ID #, DRIVE ID #, or UPDATE IDS NOW is displayed.
  - AUTOLOADER ID # stands for the current SCSI ID of the autoloader controller. DRIVE ID # is the current SCSI ID of the drive. UPDATE IDS NOW is used to save ID settings.
2. **Press Next until the setting to change is displayed, and then press Enter. The current SCSI address flashes.**

3. Press the Next or Prev button until the desired address is displayed, and then press Enter.

4. Press the Next button until UPDATE IDs NOW is displayed, and press Enter.

One of the following messages is displayed:

- If the new settings do not conflict with other SCSI IDs on the bus, IDs SAVED then SCSI IDs \* is displayed.
- If the drive and controller has the same ID, CONFLICT-ABORTED displays, followed by SET IDs \*.
- If a drive serial communications error is detected while trying to set the SCSI IDs, DRV CONNECT ERR displays, followed by IDs NOT CHANGED. Any changes entered are lost, returning you to the SCSI IDs \* menu.

5. Press Cancel three times to move back up the menus.



---

**Caution** – Consult the system administrator before power cycling.

---

6. After changing the settings, you can save the new settings to flash ROM by power cycling the Autoloader, which enables the settings to be recovered if the Autoloader is powered off for more than ten days.

If this step is not completed and the Autoloader is turned off for more than 10 days, the new settings may be lost.

---

**Note** – After changing an address, reboot the host for it to recognize the new SCSI IDs (Boot - r). Refer to the operating system documentation before rebooting.

---

## 4.4.2 Viewing SCSI IDs

1. To view SCSI IDs, press the Next key to enter the following:

```
ADMIN * / PSWD ### ### ### / SCSI IDs * / VIEW IDs *
```

2. In SET IDs \*, press Next until VIEW IDs \* is displayed. Press Enter.

3. AUTOLOADER ID # or DRIVE ID # is displayed. (AUTOLOADER ID # stands for the current SCSI ID of the autoloader controller, and DRIVE ID # is the current SCSI ID setting for the drive.)

4. Press Cancel until the next desired operation is displayed.

---

## 4.5 Cleaning the Autoloader Tape Drive

To clean the tape drive, press the Next key to enter the following:

```
ADMIN * / PSWD ### ### ### / CLEAN DRIVE *
```

---

**Note** – Use a DLT cleaning cartridge to clean the drive. The drive mechanism should only be cleaned if the clean drive status indicator displays (See Section 3.4, “Understanding Display Messages,” on page 3-7). Excessive use of the cleaning cartridge can cause unnecessary wear on the drive head. If the cleaning cartridge needs to be replaced (after 20 cleaning cycles), REPLACE CLEANING is displayed.

---

- 1. Starting at the top-level menu, press Next until ADMIN \* appears in the display window, and then press Enter.**
- 2. Enter the password.**

INFO \* displays.
- 3. Press the Next button until CLEAN DRIVE \* is displayed, and press Enter.**
  - If the power has been turned off or the access door has been opened since a cleaning cartridge location has been selected, SET CLEAN CART \* is displayed. Press Enter and select a slot location.
  - If the power has not been turned off or the access door has not been opened since a cleaning cartridge location has been selected, CLN CART LOC # displays. (# is flashing and is the cleaning cartridge storage slot location last selected.) If the storage slot location is correct, press Enter and go to step 4. To select a different slot location, press the Next or Prev button until the correct slot location is displayed, press Enter, and go to step 4.
- 4. If tape is in the drive, the status will display to indicate that the drive must be emptied before cleaning.**
  - If the slot location chosen in step 3 did not contain a cleaning cartridge, the message NOT CLEAN CART displays briefly and then CLEAN FAIL # displays. Press Cancel twice to return to the ready state. Locate the cleaning cartridge. If no cleaning cartridge is present, insert one into an available slot.
  - In the event of a drive error, such as a serial communications failure, FAILED displays and then the CLEAN DRIVE \* menu is displayed.
- 5. Press Cancel until the next desired operation is displayed.**

---

## 4.6 Configuring the Autoloader

1. To configure the Autoloader, press Next to enter the following:

`ADMIN * / PSWD ### ### ### / CONFIG *`

2. In the CONFIG \* menu, press Next or Prev until the name of the operation is displayed, then press Enter.  
If the selection has multiple settings, the current setting flashes.
3. Press the Next or Prev button until the desired setting is displayed.
4. Press the Next or Prev button to change the setting. Press Enter to select the setting. OPTION SAVED is displayed.
5. Press Cancel to move back up through the menus.

TABLE 4-2 describes the available configuration options.

**TABLE 4-2** Configuration Options

Config Name	Description	Default
RECOVERY ON/ OFF	Toggles between ON and OFF. If set to ON, the Autoloader attempts to recover from errors. If set to OFF the Autoloader stops moving if an error occurs. Recovery should remain ON under normal conditions.	ON
RESTORE DEFAULTS	Sets all configuration options to their default settings.	—
CLEAR ODOMETERS	Sets all odometers to zero.	—
NEW PASSWORD	Enables the password to be changed.	—
SCSI LOG ON/OFF	Toggles between ON and OFF. Tracks <i>internal</i> SCSI states and saves the information to a log.	OFF
SECURE ON/OFF	Toggles between ON and OFF. When set to ON, the door will not open. When set to OFF, the door will open.	OFF

**TABLE 4-2** Configuration Options (*Continued*)

Config Name	Description	Default
POWER SECURE ON/OFF	Toggles between ON and OFF. When set to ON, the SECURE ON/OFF setting is retained in the event of a power outage. When set to OFF, the Autoloader returns to its default setting of SECURE OFF when power is restored.	OFF
REP RECOVERED ON/OFF	Toggles between ON and OFF. When set to ON, recovered errors are reported; when set to OFF, the recovered errors are not reported.	ON
AUTOLOAD ON/OFF	Toggles between ON and OFF. When set to OFF in the Stacker mode, a tape must be loaded into the drive using the front panel. When set to ON, the first available tape is loaded when the unit is powered and in Stacker mode, with the drive empty.	OFF
COMPRESSION ON/OFF	Displays current setting drive compression. Toggles between ON and OFF. When set to ON, the drive will compress data unless changed by the host. When set to OFF, the drive does will not compress unless requested by the host.	
CIRCULAR ON/OFF	Toggles between ON and OFF. When set to ON, the first tape is reloaded after the last tape unloads. This option only functions in Stacker or Autodetect mode.  <i>Caution:</i> Data overwrite can occur if this option is not used carefully.	
INQ TOGGLE	Toggles between ON and OFF. When set to ON, the inquiry string for the product family is reported to the SCSI bus. When set to OFF, the inquiry string for this autoloader model is reported to the SCSI bus.  <i>Note:</i> The inquiry string for the product family and model number is currently the same.	OFF



## 4.7 Retrieving Autoloader Information

1. To retrieve autoloader information, enter the following:

```
ADMIN * / PSWD ### ### ### / INFO *
```

When using `INFO *`, records of the autoloader operation is displayed. The records are called information logs and are described in TABLE 4-3.

2. When `INFO *` displays, press Enter.
3. Press the Next button until the desired log displays and then press Enter.
4. Press Cancel to return to the ready state.

TABLE 4-3 describes the available information logs.

TABLE 4-3 Information Logs

Log Name	Description
LOADER FW	Displays the Autoloader's firmware revision number.
DRIVE FW	Displays the drive's firmware revision number.
MECH FW	Displays the loader mechanism's firmware revision number.
LIB ODOMETERS *	Press Enter to select the odometer logs for hours, moves, and drive loads.
HARD ERRORS * see Section 4.10, "Understanding Error Messages" on page 4-13	Displays a log of commands that did not complete. Returns either NO HARD ENTRIES or ENTRY #. Press Enter to view the log for the currently displayed error. Press the Next button to view the next error.
SOFT ERRORS * see Section 4.10, "Understanding Error Messages" on page 4-13	Displays a log of commands successfully completed. After an error, returns either NO SOFT ENTRIES or ENTRY #. Press Enter to view the log for the currently displayed error. Press the Next button to select the next error.

\* Press Enter to display additional error information.

## 4.8 Running an Internal Test

1. To run an internal test, press the Next key to enter the following:

```
ADMIN * / PSWD ### ### ### / TEST *
```

2. When TEST \* is displayed, press Enter.
3. Press the Next button until the desired test is displayed, and press Enter.
4. NUM LOOPS 1 is displayed, where the 1 is flashing. Press Next until the number of the desired test loop is displayed, then press Enter.

---

**Note** – Press Cancel at any time to abort a test. The last test cycle will complete before cancelling. TEST CANCEL - WAIT is displayed while the last test cycle completes.

---

Descriptions of the internal tests available from the control panel are in TABLE 4-4.

TABLE 4-4 Tests Available From the Control Panel

Test Name	Description
EMPTY DRIVE	<i>Do not run this test if the Autoloader contains a tape cartridge with data. Moves a cartridge out of the drive mechanism and returns it to its home storage slot if the locations are known, otherwise a cartridge is placed into the first available storage slot.</i>
REWIND MEDIA	<i>Do not run this test if the Autoloader contains a tape cartridge with data. Rewinds the tape in the drive and opens the solenoid in the drive handle. Go to OPEN DRV HANDLE to open the drive and remove the tape.</i>
LOAD/UNLOAD	Selects a random full slot and moves the tape to the drive. After the tape loads, the transport moves to another slot and then returns to the drive, unloading the tape to its home slot.
DRIVE IO	If the drive is empty, moves a tape cartridge from a random full slot to the drive. If the drive is full, moves a tape cartridge from the drive to the transport. It then moves the cartridge back to its original location. FAIL is displayed if there are no cartridges in the autoloader or if all storage slots are full.
SLOT IO	Moves a tape from a random full slot to the transport. The tape is then moved back to its home slot.

**TABLE 4-4** Tests Available From the Control Panel (*Continued*)

Test Name	Description
CLOSE DRV HANDLE	Closes the drive handle. Only one operation is performed, regardless of the loop count chosen.
OPEN DRV HANDLE	Use this test after performing the REWIND MEDIA test to manually remove tapes. Opens the drive handle. Only one operation is performed, regardless of the loop count chosen.
INIT MECHANICS	Performs the power-on self-tests. Each test is run one time per test loop.
CHECK INVENTORY	Functions the same as the SCSI Initialize Element Status command. This test physically scans the entire unit to determine which storage slots contain tape cartridges and if the drive contains a cartridge.  <i>Note:</i> This test will be displayed as ISTAT TEST in all control panel error messages.
EXERCISE MECH	Runs the TEST, TRANSLATE TEST, IO MAGAZINE, and IO DRIVE tests. Each test is run one time per test loop.
EMPTY TRANSPORT	Moves the tape in the transport back to the original slot. The test passes if the transport is empty.
TRANSPORT MOTOR	Runs the cartridge motor in the transport back and forth.
PLUNGE TEST	Runs the cartridge pusher back and forth.
TRANSLATE TEST	Translates from side to side. No tape cartridge is required.
DOOR LOCK	Locks the door.
DOOR UNLOCK	Unlocks the door.
DOOR SENSOR	Displays if the door is open or not.
PUSH SENSOR 1	Displays the value of picker sensor 1.
PUSH SENSOR 2	Displays the value of picker sensor 2.
DOOR LOCK SENSOR	Displays if the door is locked or not.
DRV HNDL OPEN SENSOR	Displays the current value of the drive handle open sensor.
DRV HNDL CLOSE SENSOR	Displays the current value of the drive handle close sensor.
T MAG SENSOR	Displays the current value of the magazine side transport sensor.
T DRIVE SENSOR	Displays the current value of the drive side transport sensor.
MAG PRESENT SENSOR	Displays the current value of the magazine present sensor.

---

## 4.9 Drive Cleaning Errors

TABLE 4-5 describes situations that can cause the drive cleaning message, CLEAN DRIVE is displayed when a tape cartridge may be at fault.

For drive cleaning instructions, refer to Section 4.5, “Cleaning the Autoloader Tape Drive” on page 4-6.

**TABLE 4-5** Drive Cleaning Troubleshooting

If this happens . . .	The reason is . . .	So you need to . . .
A brand new tape cartridge is used and a drive cleaning message is received.	Debris from the tape manufacturing process was deposited on the drive head.	Clean the drive using the tape library cleaning procedure on Section 4.5, “Cleaning the Autoloader Tape Drive” on page 4-6.  If the message is displayed again within a short amount of time, replace the cartridge.
An older, frequently-used tape cartridge is loaded and a drive cleaning message is received.	Dust from frequent tape loads and unloads has probably built up on the tape cartridge and deposited on the drive head.	<ol style="list-style-type: none"><li>1. Clean the <i>outside</i> of the tape cartridge using a damp cloth.</li><li>2. Clean the tape drive using the tape drive cleaning procedure found in Section 4.5, “Cleaning the Autoloader Tape Drive” on page 4-6.</li></ol>
An older, frequently-used tape causes a cleaning message to be displayed for the second time.	The tape is probably damaged. (Damaged cartridges can result in unnecessary use of the cleaning cartridge.)	<ol style="list-style-type: none"><li>1. Verify the tape is readable by clearing the error message.</li><li>2. Try reading the tape again.<ul style="list-style-type: none"><li>• If the tape can be read, back up data from the damaged cartridge to another tape cartridge, and discard the damaged one.</li></ul></li></ol>

---

## 4.10 Understanding Error Messages

When receiving an error code, the display window will display a message similar to the following:

**DEVICE FAILED**  
**ERROR CODE 94H**

To understand an error code:

- 1. Press Enter to get a brief description about the error code.**
- 2. Press the Next button to get the following information:**
  - Motion Type
  - Source
  - Destination 1
  - Destination 2
  - Odometer
  - Field Replaceable Unit (see description below)
  - Error Listing (last 5 transport errors)
  - Error Count (Number of errors on this move)

## 4.10.1 Field Replaceable Units (FRUs)

---

**Note** – A FRU is a part that can be replaced in the field.

---

When an error occurs, press Enter then Next to obtain information about the following FRU messages. TABLE 4-6 describes what each FRU display message means and the recommended replacement procedure.

**TABLE 4-6** FRUs (Field Replaceable Units)

FRU Number displayed on front panel	Probable Cause of Failure	Recommended Replacement
FRU #1	SCSI controller	Unit minus the drive
FRU #7	Drive	Drive
FRU #28	Loader mechanics	Unit minus the drive

## 4.10.2 Recovery

If the Autoloader does not recover from an error in normal operation, remove the magazine and all the tapes and power cycle. If the Autoloader fails again, it must be exchanged. If the Autoloader powers up successfully, reload the tapes and retry the failed operation. If the Autoloader does not recover from an error in normal operation, remove the magazine and all the tapes and power cycle. If the Autoloader files again, it must be exchanged. If the Autoloader powers on successfully, reload the tapes and retry the failed operation.

**TABLE 4-7** Error Codes

Hex Error	Probable Cause
01H	ROM checksum error.
02H	Register error.
03H	Microprocessor error.
04H	Controlled area of RAM checksum error.
05H	RAM test error.
06H	SCSI chip error.
07H	Library controller chip error.
2DH	Door is open.

**TABLE 4-7** Error Codes (Continued)

Hex Error	Probable Cause
32H	Invalid test number.
33H	Invalid configuration.
34H	Need to run INVENTORY CHECK test.
35H	Exercise test failed.
36H	Elements reserved.
3CH	Move to.
3FH	Put magazine in.
40H	Get magazine out.
42H	Put drive in.
43H	Get drive out.
5EH	Powerfail clear path.
5FH	Powerfail restore tapes.
80H	No error.
81H	Invalid command error. This error indicates that the loader received an undefined or invalid parameter to a command.
82H	Undefined error code.
83H	Undefined error code.
84H	Tape in transit after a reset or poweron. This error occurs after a powercycle.
85H	Did not find pusher home-position during mechanical initialization.
86H	Did not find PUSHPOS 1 during mechanical initialization.
87H	Time out moving a tape onto or off of the transport during mechanical initialization.
88H	Time out finding the transport home position during mechanical initialization.
89H	Time out finding PUSHPOS 2 during mechanical initialization.
8AH	Did not leave DRIVPOS during mechanical initialization.
8BH	No drive handle installed or time out closing drive handle during mechanical initialization.

**TABLE 4-7** Error Codes (Continued)

Hex Error	Probable Cause
8CH	Time out during pusher test. Did not leave home position.
8DH	Time out during pusher test finding pusher home position.
8EH	Time out during pusher test or during transport home position moving from pusher home position toward PUSHPOS 2.
8FH	Undefined error code.
90H	No tape in drive during tape unload.
91H	Time out finding PUSHPOS 1 (position in front of the drive before unloading a tape from the drive onto the transport).
92H	Time out opening the drive handle during a tape unload. The library controller determines if the drive is still in the unload state after receiving this error code. If the drive is in the unloaded state, the command can be retried by reissuing the command. If the drive is not in the unload state, then an unload command must be issued before retrying this command.
93H	Time out finding the pusher home position during a tape unload.
94H	Time out moving tape from the drive onto the transport. If this error occurs, the loader controller will try to move the tape back into the drive.
95H	Time out moving the transport from the drive load position to the slot position during a tape unload.
96H	Time out finding PUSHPOS 1 during a tape unload.
97H	Time out unloading a tape into the slot during tape unload.
98H	Time out finding the pusher home position during a tape unload. This error occurs after the tape was successfully placed back into the magazine so the move is effectively completed.
99H	Time out moving the transport to DRIVPOS during a tape unload.
9AH	Time out finding PUSHPOS 2 during a CARTRIDGE UNLOAD command.
9BH	Could not unlock the door during an UNLOCK DOOR command.



**TABLE 4-7** Error Codes (Continued)

Hex Error	Probable Cause
9CH	Did not find all of the valid slot positions during a SCAN MAGAZINE command.
9DH	Time out (did not leave a tape type window during a SCAN MAGAZINE command).
9EH	Time out leaving DRIVPOS during a SCAN MAGAZINE command.
9FH	Could not lock the door during a door lock command or during a scan command if the door is unlocked.
A0H	Tape is already in the drive during a LOAD CARTRIDGE command.
A1H	No tape in the selected slot during a LOAD CARTRIDGE command.
A2H	Time out moving the transport to the slot position during a LOAD CARTRIDGE command.
A3H	Time out finding PUSHPOS 1 during a LOAD CARTRIDGE command.
A4H	Time out moving a tape from the slot onto the transport during a LOAD CARTRIDGE command.
A5H	Time out finding the pusher home position during a LOAD CARTRIDGE command.
A6H	Time out moving the transport to the drive-load position during a LOAD CARTRIDGE command.
A7H	Time out opening the drive handle during a LOAD CARTRIDGE command.
A8H	Time out moving a tape from the transport into the drive during a LOAD CARTRIDGE command.
A9H	Time out finding PUSHPOS 2 to push tape completely into the drive during a LOAD CARTRIDGE command.
AAH	This code is not an error. It is used in the error trace buffer to indicate 1,000 cycles.
ABH	Time out finding PUSHPOS 1 (rack waiting position in front of the drive).
ACH	Time out closing the drive handle.
ADH	Time out leaving the drive load position to move to the drive park position.

**TABLE 4-7** Error Codes (Continued)

Hex Error	Probable Cause
AEH	Time out moving the tape back into a slot after error A4. This error could only happen if the loader controller tries to move a cartridge from the slot onto the transport and it fails. The loader controller would then try to move the tape back into the slot. If it fails, this error occurs.
AFH	Undefined error code.
B0H	Undefined error code.
B1H	Desktop mode.
B2H	Door open without receiving a command. After power is turned on, this command can occur as the loader remembers the state of the door.
B3H	Unit was reset or powered on.
B4H	Time out repositioning the transport during a repositioning command.
B5H	Did not find all expected slots during transport movements. This error can occur during a load or an unload of a tape or a reposition command.
B6H	Undefined error code.
B7H	UART test failure.
B8H	Undefined error code.
B9H	Undefined error code.
BAH	Undefined error code.
BBH	Ram error.
BCH	ROM error.
BDH	CTC error.
BEH	Undefined error code.
BFH	Undefined error code.

---

## 4.11 Troubleshooting

For problems that are related to the host or application software, refer to the host system documentation or to the application software instructions.



---

**Caution** – Consult the system administrator before cycling power. Never cycle power when active devices are connected to the SCSI bus. Pressing the power button when the SCSI system is active can cause data loss or problems with the SCSI interface.

---

TABLE 4-8 describes solutions to possible operation problems.

**TABLE 4-8** Troubleshooting Table

Problem	What to Do
Autoloader will not power on.	<ul style="list-style-type: none"><li>• Check the power cord connections.</li><li>• Make sure the power switch is on.</li><li>• Make sure there is power to the outlet.</li><li>• Replace the power cord with a known good one.</li><li>• Replace the unit.</li></ul>
Power-on self-test failed. DEVICE FAILED is displayed in the display window with an error code on the next line.	<ul style="list-style-type: none"><li>• Verify that all tapes are fully inserted in the magazine and that the magazine is securely locked into position inside the autoloader.</li><li>• Cycle power.</li><li>• If the power-on test fails again, press Enter to interpret the error code.</li></ul>
The Autoloader's power failed while a tape was in the drive and did not return to the ready state after the power came on.	<ul style="list-style-type: none"><li>• Press the power switch off and then on again to run the power-on test.</li></ul>
No messages are displayed.	<ul style="list-style-type: none"><li>• Make sure the power cord is connected.</li><li>• Make sure the power switch is on.</li><li>• Power cycle the Autoloader.</li></ul>

**TABLE 4-8** Troubleshooting Table (Continued)

Problem	What to Do
An error message appears after inserting the magazine or loading tapes.	<ul style="list-style-type: none"> <li>• Verify that tapes are inserted correctly in the magazine. (See Section 3.2, "Loading/Unloading Tape Cartridges into the Autoloader," on page 3-2.)</li> <li>• Verify that the correct tape type is used (Type IIIXT &amp; IV).</li> <li>• If the activity light on the display panel is amber, power cycle the Autoloader and try to load the magazine again when the drive and status indicators display.</li> <li>• If SECURITY ENABLED is displayed, a security option has been set that prevents tapes from being loaded into or removed from the Autoloader. See Section 4.6, "Configuring the Autoloader" on page 4-7.</li> </ul>
Error Code Hex 62 is displayed.	<ul style="list-style-type: none"> <li>• Remove tapes from internal storage slots.</li> <li>• Power cycle the unit.</li> </ul>
Changed drive SCSI ID but the new ID is not recognized.	<ul style="list-style-type: none"> <li>• Use the VIEW ID option to verify that the new ID was saved after selecting UPDATE IDs.</li> <li>• Power the changer and reboot the host.</li> </ul>
Cannot remember the administration menu password.	<ul style="list-style-type: none"> <li>• Enter the default password (000-000-000).</li> </ul>
Attempted to open the front access door, but a RESERVED message is displayed.	<ul style="list-style-type: none"> <li>• The host may have reserved an element (slot or drive) and must unreserve it. Refer to the host system documentation to unreserve a tape.</li> <li>• A security configuration was set to prevent tape removal. See SECURE ON/OFF in the list of configuration options found in Section 4.6, "Configuring the Autoloader" on page 4-7.</li> </ul>
Started a test and need to stop.	<ul style="list-style-type: none"> <li>• Press Cancel. The current test loop continues until finished, then the test stops.</li> </ul>
OVERFULL is displayed.	<ul style="list-style-type: none"> <li>• Power the unit off.</li> <li>• Remove the magazine.</li> <li>• Remove a tape from the rear slot.</li> <li>• Close the door and power on.</li> </ul>
DO INVENTORY TEST is displayed.	<ul style="list-style-type: none"> <li>• Power cycle the Autoloader, or run the INVENTORY CHECK test under the TEST * menu.</li> </ul>

**TABLE 4-8** Troubleshooting Table (Continued)

Problem	What to Do
Cannot write to the tape.	<ul style="list-style-type: none"> <li>• Check the host file system access permissions.</li> <li>• Verify that you are using the correct tape type (Type IIIXT &amp; IV).</li> <li>• Check the write-protect tab on the tape to assure write-enabled status.</li> <li>• Check the application software documentation.</li> </ul>
Cannot read the tape.	<ul style="list-style-type: none"> <li>• Check the host file system access permissions.</li> <li>• Verify that you are using the correct tape type (Type IIIXT &amp; IV).</li> <li>• Check the application software documentation.</li> </ul>
Slot blocked (magazine or permanent)	<ul style="list-style-type: none"> <li>• Open door, and remove magazine.</li> <li>• Check for and remove any obstruction. Cycle power.</li> </ul>
Magazine will not go in.	<ul style="list-style-type: none"> <li>• Open door. Check for and remove obstruction.</li> <li>• Check for damage to the magazine rails (bottom and top of autoloader) and magazine slots and outside of magazine for wear. Replace the magazine necessary.</li> </ul>
Magazine will not come out.	<ul style="list-style-type: none"> <li>• Open door. Check for and remove any obstruction.</li> </ul>
Picker won't access the two permanent storage slots.	<ul style="list-style-type: none"> <li>• Open door. Check for and remove any obstruction.</li> </ul>
Recurrent cleaning light on.	<ul style="list-style-type: none"> <li>• Replace existing tape with a new tape. See Section 4.9, "Drive Cleaning Errors" on page 4-12.</li> </ul>
Could not find all slot positions in a SCAN MAGAZINE command.	<ul style="list-style-type: none"> <li>• Verify that all small holes at the bottom inside edge of the magazine are clean.</li> </ul>
Autoloader will not power on.	<ul style="list-style-type: none"> <li>• Check the power cord connections.</li> <li>• Make sure the power switch is on.</li> <li>• Make sure there is power to the outlet.</li> <li>• Replace the power cord with a known good one.</li> </ul>
Release door menu option will not release the door.	<ul style="list-style-type: none"> <li>• Press and hold the Cancel button from three to five seconds.</li> </ul>



# Removal and Replacement

---

This chapter explains how to:

- Replace a unit
- Replace the drive
- Remove stuck tapes

---

## 5.1 Replacing a Unit

When replacing a unit, you must power the failed unit down, remove and reinstall the cabling, cover, and feet onto the new unit, and power the new unit on.

---

**Note** – If you are replacing a rackmount unit, unscrew the unit from the shelf, slide the unit out, and follow the steps below. See Section 1.2.1, “Mounting the Autoloader,” on page 1-7 for more details.

---

1. **Remove all tapes from the failed unit. See Section 3.2, “Loading/Unloading Tape Cartridges Into the Autoloader,” on page 3-2.**
2. **If the failed unit is still powered on, turn the standby (power) switch off, which is in the bottom left-hand corner when you are facing the unit, and unplugging the power cord.**
3. **Remove the cabling and terminator from the back of the failed unit.**
4. **Remove the cover and feet from the failed unit.**
  - a. **On the failed unit, remove the four screws on the back of the cover and the two screws on the side of the cover (FIGURE 5-1 on page 5-3).**
  - b. **Remove the cover by pulling the sides slightly out and lifting the cover up and toward the back of the unit (FIGURE 5-2 on page 5-3).**
  - c. **Unscrew and remove the four feet. You can lay the unit on its side to remove the feet.**

---

**Tip** – If the cover fits tightly near the display and is not easily removed, pull the sides out near the display panel while rotating the the cover up.

---



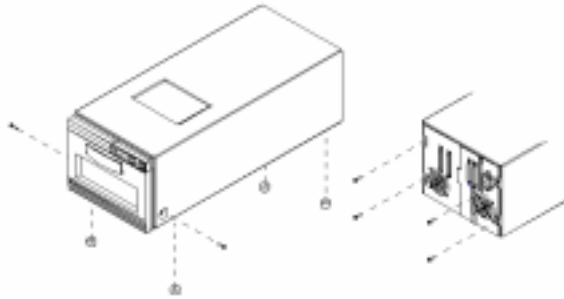

FIGURE 5-1 Removing the Feet

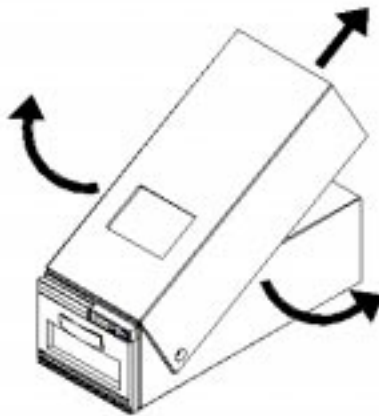

FIGURE 5-2 Removing the Cover

5. **Install the cover and feet in the same position as** FIGURE 5-1.
6. **Connect the cabling and terminator on the new unit. See** Section 1.3, “Connecting the Autoloader,” on page 1-14 for this procedure.
7. **Power the unit on. See** Section 1.4, “Powering on the System,” on page 1-16..
8. **Load the tapes into the new unit. See** Section 3.2, “Loading/Unloading Tape Cartridges Into the Autoloader,” on page 3-2.

---

## 5.2 Replacing the DLT Drive

---

**Note** – If you are replacing the DLT drive on a rackmounted unit, unscrew the unit from the shelf, slide the unit out, and follow the steps below. See Section 1.2.1, “Mounting the Autoloader,” on page 1-7 for more details.

---

1. Power down the unit by unplugging the power cord from the back of the unit.
2. Disconnect remaining external cables.
3. Remove the seven screws on the DLT drive’s rear plate. See FIGURE 5-3 for screw locations.

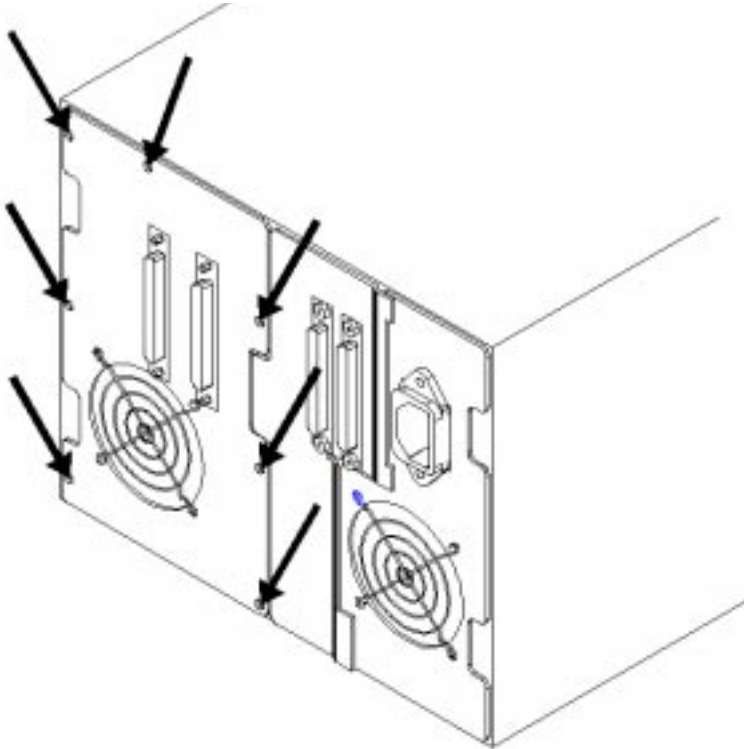

FIGURE 5-3 Screw Locations

4. Gently pull out the DLT drive partially, taking care not to damage the cables.

5. Disconnect the following four cable connectors, which are labeled in FIGURE 5-4.

---

**Note** – It is unnecessary to remove the internal SCSI ribbon cable from the back of the DLT drive.

---

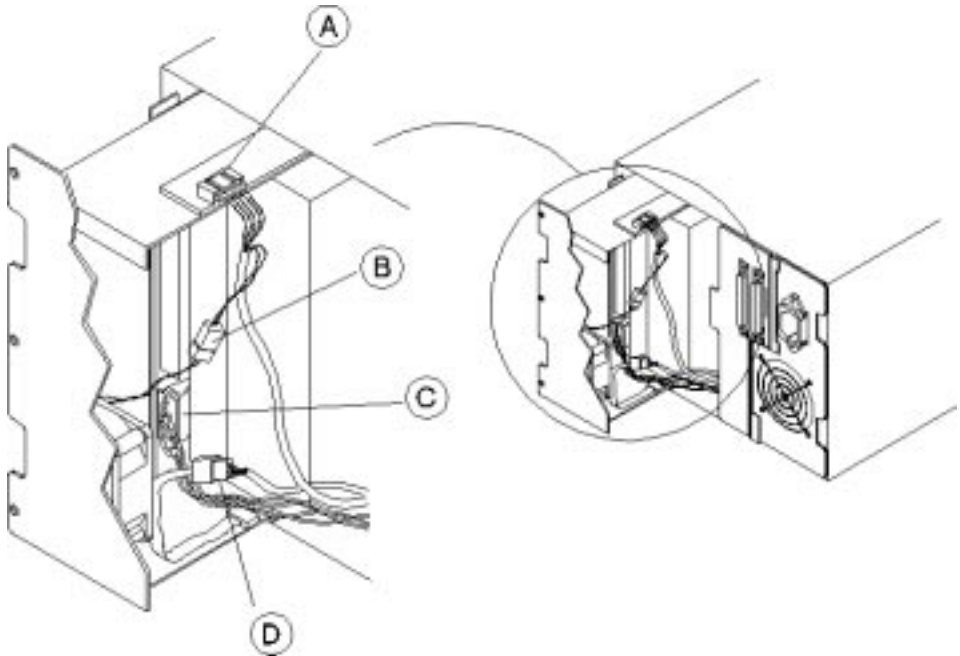

**FIGURE 5-4** Drive Cables

**TABLE 5-1** Cable Connectors

A	DLT Drive handle motor
B	Fan
C	Power (DC)
D	DLT Drive to loader

6. Hold the four cable connectors to the right side of the unit, and remove the DLT drive.

## 5.2.1 Reassembly

1. **Partially slide in the new DLT drive. Reconnect the four cable connectors. See FIGURE 5-4 on page 5-5.**
2. **Taking care not to damage the cables, insert the DLT drive into the unit.**
3. **Install the seven screws on the drive's rear plate. See FIGURE 5-3 on page 5-4 for screw locations.**

---

**Note** – Connect the power cable last.

---

4. **Connect the external cables. See Section 1.3, “Connecting the Autoloader,” on page 1-14 for the procedure.**
5. **Power the unit on. See Section 1.4, “Powering on the System,” on page 1-16 for the procedure.**

---

## 5.3 Removing Stuck Tapes

### 5.3.1 Tape Stuck in Transport

1. Run the **EMPTY TRANSPORT TEST** under the **TEST \* menu**.  
If this fails, go to step 2.
2. Power down the unit by unplugging the power cord from the back of the unit
3. Open the door, and remove the magazine.
4. Try to remove the tape by grasping it with your fingers.
5. Turn the upper aluminum slotted shaft clockwise to eject the tape.  
If you cannot turn this shaft or if the tape does not eject, rotate the lower shaft to release the tape.
6. Gently remove the tape.

### 5.3.2 Tape Stuck Between Magazine and Transport

1. Power down the unit by unplugging the power cord from the back of the unit.
2. Take out the magazine.
3. Remove the tape.

### 5.3.3 Tape Stuck in Internal Slots or Magazine

1. Try to remove the tape by releasing the door and removing the tape with your fingers. If you are unsuccessful, continue with the next step.
2. Power down the unit by unplugging the power cord from the back of the unit
3. Gently ease the transport out of the way.
4. Gently press the silver tab down to remove the tape by hand.  
Once depressed, the tape should eject.
5. Remove the tape with your fingers.

## 5.3.4 Tape Stuck in DLT Drive



---

**Caution** – If a tape is stuck in the DLT drive, the drive must be replaced.

---

1. Run the **TRANSLATE TEST** to move the transport out of the way.
2. Run the **REWIND MEDIA** test to rewind the tape. If you are unable to rewind the tape, go to step 5 of this section.
3. Use the **OPEN DRV HANDLE** internal test to release the tape.
4. Run the **UNLOCK DOOR** test to release the front door.



---

**Caution** – Do not use the **RELEASE DOOR** option because this will move the transport with the stuck tape and cause further damage.

---

5. Open the door and remove the tape. If you are still unable to remove the tape, proceed to the next step.

---

**Note** – Only manually unload the tape if it is imperative that the customer retain the tape. If not, keep the tape in the DLT drive to help with failure analysis.

---

6. Remove the DLT drive by following the steps in “Replacing the DLT Drive” on page 5-4.
7. Inspect the drive to see if any tape is on the take-up wheel. If so, see “Manually Rewinding Tapes” on page 5-11. If not, continue with step 8.

**8. Remove the drive handle motor assembly (on the right side of the drive). See FIGURE 5-5.**

**TABLE 5-2** Drive Motor Assembly

A	Disconnect the flex cable by gently pulling it out of the connector.
B	Remove the two screws.
C	Slide the assembly straight out and set it aside.

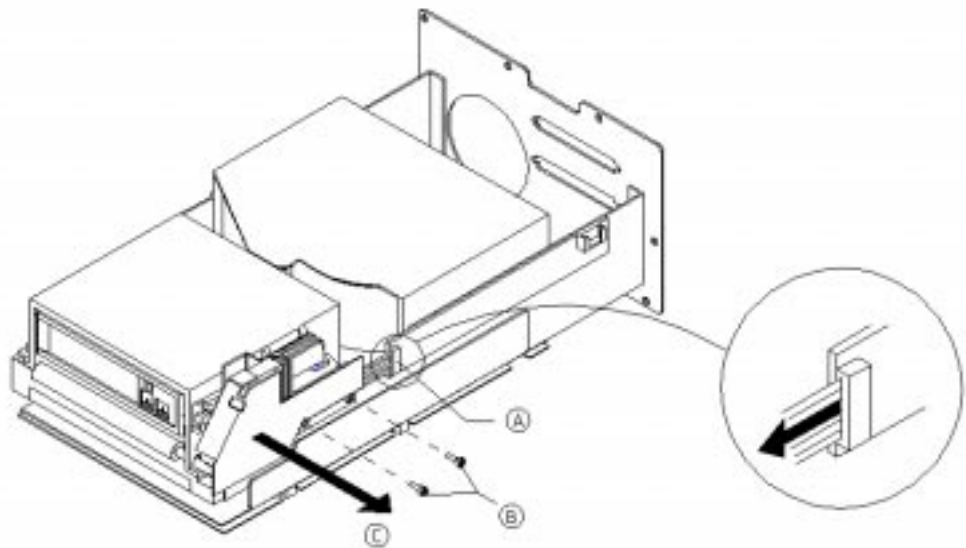

**FIGURE 5-5** Drive Motor Assembly

9. Pull out the solenoid mechanism while gently turning the D-shaft clockwise with pliers to eject the tape (FIGURE 5-6).

TABLE 5-3 Solenoid Mechanism

A	Solenoid Mechanism
B	D-shaft

---

**Note** – Ensure that both the top and bottom tabs of the solenoid are pulled out.

---

10. If you are able to eject the tape and the leader is retracted, restore and save the tape data, then discontinue using that tape.

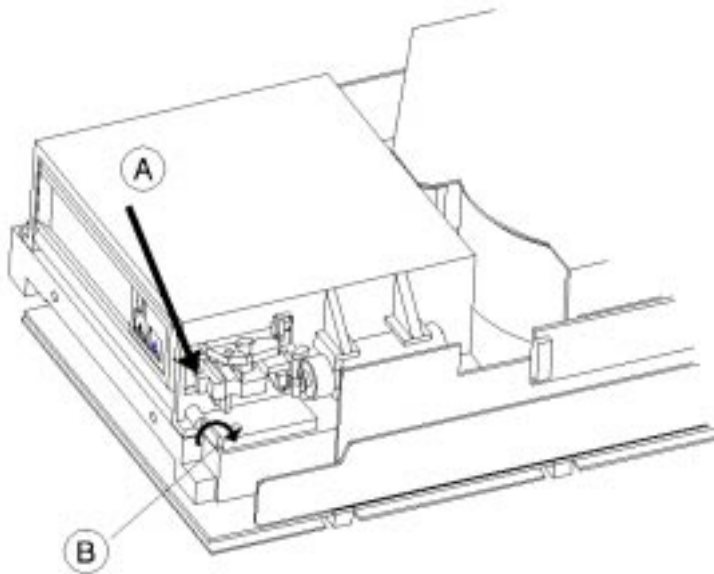

FIGURE 5-6 Ejecting the Tape



## 5.3.5 Manually Rewinding Tapes

1. When the drive is removed, lay it on its side, as shown FIGURE 5-7.
2. Insert a Phillips screwdriver into the rewind hole on the bottom of the drive.
3. Turn the screwdriver counterclockwise to rewind the tape (FIGURE 5-7).  
Continue rewinding until the leader is seated in the tape.
4. To ensure that the tape is fully rewound, check that no tape is dangling from the tape cartridge.

---

**Caution** – If the tape leader is not seated and you are unable to manually rewind the tape, an obstruction or broken tape reel lock is the likely cause. If either of these conditions exist, it may not be possible to remove the tape without damaging it. Refer the customer to data restoration facilities.

---

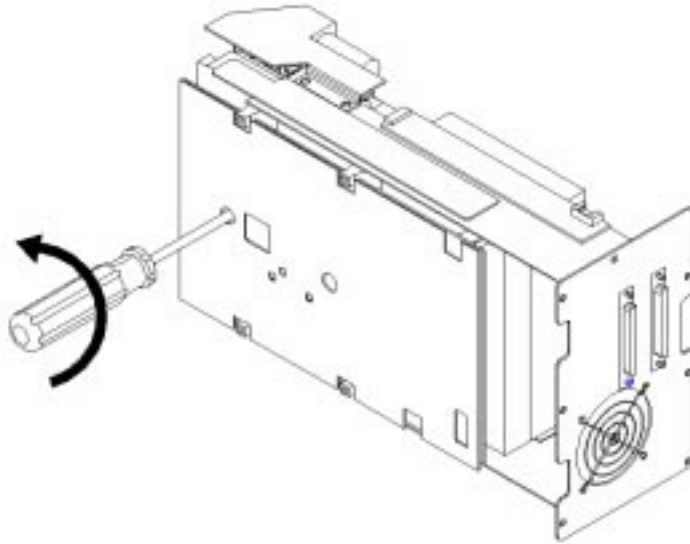

FIGURE 5-7 Rewinding a Stuck Tape



# Index

---

## A

- activity indicators, 3-8
- activity lights, 3-6
- addresses
  - setting of SCSI, 4-4
- ADMIN \* menu
  - changing the password, 4-3
- autoloader
  - information logs, 4-9
  - moving, 1-17 to 1-18
  - setting SCSI addresses, 4-4

## B

- buttons. See selection buttons

## C

- cable connections, 1-14 to 1-15
- cable management, 1-13
- cleaning the drives, 4-6, 4-12
- clearance, 1-5
- configuration options
  - listing of, 4-7 to 4-8
- control panel
  - tests, 4-10 to 4-11
- control panel,description, 3-6

## D

- declaration of conformity, xi
- display window
  - description of, 3-6
- display window messages, 3-7
- documents
  - ordering, xxiii
  - Web, xxiv
- drives
  - cleaning, 4-6

## E

- electronics, 2-7
- environmental specifications, 1-4 to 1-5
- error messages, 4-13 to 4-18

## F

- filler panel, 1-11

## I

- indicators
  - activity, 3-8
- information logs, 4-9
- installation
  - rackmounting, 1-7 to 1-12
- installation,shelf, 1-8
- internal tests, 4-10

## L

list of figures, xvii  
list of tables, xix  
loading tapes, 3-4

## M

magazine  
    inserting or removing, 3-3  
menu tree, 3-12  
moving the autoloader, 1-17 to 1-18

## O

opening the door, 3-2  
operating modes, 3-10  
options  
    password-protected, 3-10  
    top level, 3-9

## P

password  
    changing, 4-3  
    entering, 4-2  
password, changing, 4-3  
password-protected options, 3-10  
powering on, 1-16  
problems, troubleshooting table, 4-19 to 4-21

## R

rackmount installation, 1-6  
regulatory information, iii  
reliability, 2-4  
removing stuck tapes, 5-7 to 5-11  
    between magazine and transport, 5-7  
    in drive, 5-8  
    in internal slots, 5-7  
    in transport, 5-7

## S

safety statements, v to ix  
SCSI addresses

    setting, 4-4  
    viewing current, 4-5  
security code, setting, 4-6  
setting SCSI addresses, 4-4 to 4-5  
shipping the autoloader, 1-19  
specifications  
    autoloader and drive, 1-3  
    physical, 1-2  
status indicators, 3-8  
support, xxiv

## T

table of contents, xiii  
tape drives  
    cleaning, 4-6, 4-12  
tapes  
    cleaning issues, 4-12  
    loading, 3-4 to 3-5  
    unloading, 3-5  
technical specifications, 1-2 to 1-3  
tests  
    running, 4-10  
theory of operation, 2-1 to 2-7  
    autoloader design, 2-2 to 2-3  
    desktop design, 2-1  
    firmware, 2-4 to 2-6  
    rackmount design, 2-1  
top level options, 3-9  
troubleshooting, 4-19 to 4-21  
typographic conventions, xxii

## U

unloading tapes, 3-5