



Sun StorageTek® SL500 Modular Library System

Interface Reference Manual

Part Number: 96122

Revision: G

August 2009



Sun StorageTek SL500 Modular Library System

Interface Reference Manual

Sun Microsystems, Inc.
www.sun.com

Part Number: 96122
August 2009
Revision: G

**Copyright © 2006, 2009 Sun Microsystems, Inc., 4150 Network Circle, Santa Clara, California 95054, U.S.A.
All rights reserved.**

Sun Microsystems, Inc. has intellectual property rights relating to technology that is described in this document. In particular, and without limitation, these intellectual property rights may include one or more of the U.S. patents listed at <http://www.sun.com/patents> and one or more additional patents or pending patent applications in the U.S. and in other countries.

This document and the product to which it pertains are distributed under licenses restricting their use, copying, distribution, and decompilation. No part of the product or of this document may be reproduced in any form by any means without prior written authorization of Sun and its licensors, if any.

Third-party software, including font technology, is copyrighted and licensed from Sun suppliers.

Parts of the product may be derived from Berkeley BSD systems, licensed from the University of California. UNIX is a registered trademark in the U.S. and in other countries, exclusively licensed through X/Open Company, Ltd.

Sun, Sun Microsystems, the Sun logo, Java, AnswerBook2, docs.sun.com, and Solaris, Storage Technology, and StorageTek are trademarks or registered trademarks of Sun Microsystems, Inc. in the U.S. and in other countries.

All SPARC trademarks are used under license and are trademarks or registered trademarks of SPARC International, Inc. in the U.S. and in other countries. Products bearing SPARC trademarks are based upon an architecture developed by Sun Microsystems, Inc.

The OPEN LOOK and Sun™ Graphical User Interface was developed by Sun Microsystems, Inc. for its users and licensees. Sun acknowledges the pioneering efforts of Xerox in researching and developing the concept of visual or graphical user interfaces for the computer industry. Sun holds a non-exclusive license from Xerox to the Xerox Graphical User Interface, which license also covers Sun's licensees who implement OPEN LOOK GUIs and otherwise comply with Sun's written license agreements.

U.S. Government Rights—Commercial use. Government users are subject to the Sun Microsystems, Inc. standard license agreement and applicable provisions of the FAR and its supplements.

DOCUMENTATION IS PROVIDED "AS IS" AND ALL EXPRESS OR IMPLIED CONDITIONS, REPRESENTATIONS AND WARRANTIES, INCLUDING ANY IMPLIED WARRANTY OF MERCHANTABILITY, FITNESS FOR A PARTICULAR PURPOSE OR NON-INFRINGEMENT, ARE DISCLAIMED, EXCEPT TO THE EXTENT THAT SUCH DISCLAIMERS ARE HELD TO BE LEGALLY INVALID.

Copyright 2006, 2009 Sun Microsystems, Inc., 4150 Network Circle, Santa Clara, California 95054, Etats-Unis.
Tous droits réservés.

Sun Microsystems, Inc. a les droits de propriété intellectuelle relatants à la technologie qui est décrit dans ce document. En particulier, et sans la limitation, ces droits de propriété intellectuelle peuvent inclure un ou plus des brevets américains énumérés à <http://www.sun.com/patents> et un ou les brevets plus supplémentaires ou les applications de brevet en attente dans les Etats-Unis et dans les autres pays.

Ce produit ou document est protégé par un copyright et distribué avec des licences qui en restreignent l'utilisation, la copie, la distribution, et la décompilation. Aucune partie de ce produit ou document ne peut être reproduite sous aucune forme, par quelque moyen que ce soit, sans l'autorisation préalable et écrite de Sun et de ses bailleurs de licence, s'il y en a.

Le logiciel détenu par des tiers, et qui comprend la technologie relative aux polices de caractères, est protégé par un copyright et licencié par des fournisseurs de Sun.

Des parties de ce produit pourront être dérivées des systèmes Berkeley BSD licenciés par l'Université de Californie. UNIX est une marque déposée aux Etats-Unis et dans d'autres pays et licenciée exclusivement par X/Open Company, Ltd.

Sun, Sun Microsystems, le logo Sun, Java, AnswerBook2, docs.sun.com, et Solaris, StorageTek, e Storage Technology sont des marques de fabrique ou des marques déposées de Sun Microsystems, Inc. aux Etats-Unis et dans d'autres pays.

Toutes les marques SPARC sont utilisées sous licence et sont des marques de fabrique ou des marques déposées de SPARC International, Inc. aux Etats-Unis et dans d'autres pays. Les produits portant les marques SPARC sont basés sur une architecture développée par Sun Microsystems, Inc.

L'interface d'utilisation graphique OPEN LOOK et Sun™ a été développée par Sun Microsystems, Inc. pour ses utilisateurs et licenciés. Sun reconnaît les efforts de pionniers de Xerox pour la recherche et le développement du concept des interfaces d'utilisation visuelle ou graphique pour l'industrie de l'informatique. Sun détient une licence non exclusive de Xerox sur l'interface d'utilisation graphique Xerox, cette licence couvrant également les licenciées de Sun qui mettent en place l'interface d'utilisation graphique OPEN LOOK et qui en outre se conforment aux licences écrites de Sun.

LA DOCUMENTATION EST FOURNIE "EN L'ÉTAT" ET TOUTES AUTRES CONDITIONS, DECLARATIONS ET GARANTIES EXPRESSES OU TACITES SONT FORMELLEMENT EXCLUES, DANS LA MESURE AUTORISEE PAR LA LOI APPLICABLE, Y COMPRIS NOTAMMENT TOUTE GARANTIE IMPLICITE RELATIVE A LA QUALITE MARCHANDE, A L'APTITUDE A UNE UTILISATION PARTICULIERE OU A L'ABSENCE DE CONTREFAÇON.

Sun is interested in improving its documentation and welcomes your comments and suggestions, you can:

- Use the OpinionLab [+] feedback system on the documentation Web site

Please include the publication name, part number, and edition number in your correspondence if they are available.
This will expedite our response.



Please
Recycle



Summary of Changes

Date	Revision	Description
August 2004	A	Initial release.
July 2005	B	See this revision for details.
September 2006	C	See this revision for details.
March 2007	D	See this revision for details.
October 2007	E	See this revision for details.
July 2008	F	See this revision for details.
September 2009	G	Included engineering mark-ups.

Change bars are used in this manual to help identify the updates.

Contents

Preface xxi

Safety xxiv

1. General Information 1

The SCSI Bus Interface 1

Overview 1

Benefits 3

Implementation 3

The Fibre Channel Standard 4

Overview 4

Benefits 4

Implementation 4

2. SCSI Bus Physical Description 7

Characteristics 7

SCSI Options 8

Interface Cables 8

External 9

Daisy-Chain 9

Connector 10

Terminator 10

Special Signals 11

Differential Sense 11

Terminator Power 11

P-cable to A-cable Adapter 12

3. SCSI Bus Operations	15
Bus Phases	15
Bus Free	16
Arbitration	17
Selection	17
Reselection	17
Information Transfer	17
Bus Signals	18
Signal Sources	19
Bus Conditions	20
Attention	20
Parity Errors	20
Reset	21
Contingent Allegiance	21
Unit Attention	22
Pointers	23
Message System	24
Message Codes	25
Command Complete Message In	25
Extended Message	25
Save Data Pointers In	25
Restore Pointers Message In	25
Disconnect Message In	25
Initiator Detected Error Out	25
Abort Out	25
Message Reject In/Out	26
No Operation Out	26
Message Parity Error Out	26
Bus Device Reset Out	26
Identify Message In/Out	26
Message Sequencing and Handling	27
Synchronous Negotiations	27
Wide Negotiations	27

Status Byte	28
Good	28
Check Condition	28
Busy	29
Reservation Conflict	29
Multiple Initiator Support	29
Host TimeOut Characteristics	30
Fast Load	30
Device Reservations	30
4. Fibre Channel Physical Interface	33
Ports	33
Topologies	34
Arbitrated Loop	34
Private Arbitrated Loop	34
Public Arbitrated Loop	34
Arbitrated Loop with Hub	35
Hubs	35
Considerations for Hubs	36
Cascading Hubs	37
Loop with a Switch and a Hub	38
Direct Fabric Attachment	38
Cables and Connectors	39
Cable Guidelines for Hubs	40
Giga-bit Interface Converters	40
5. Fibre Channel Operations	41
Fibre Channel Levels	41
Terms/Definitions	42
FC–Tape Terms	42
Sun StorageTek Terms	42
Error Detection and Management	43
FC-0 Features	44
FC-0 and Initialization	44

Device States (FC-0, FC-1, FC-2)	44
Power Up	44
Not Ready	44
Ready	44
Power Down	44
FC-1 Features	45
FC-1 and Initialization	45
8B/10B Encoding and Decoding	45
Disparity	45
FC-AL Features	46
Initialization	46
Address Processes	47
Open State/Loop Initialization	48
Related Processes	48
Completion Processes	49
Feature Set	50
Login_BB_Credit Equals Zero	51
Open and Close Latencies	51
Fabric F_PORT Attachment Initialization	51
FC-2 Features	52
Login Validation	52
Class of Service Parameters	53
Class 3 Service Parameters, Port Login	54
Class 3 Service Parameters, Fabric Login	55
Basic Commands	57
Extended Commands	57
Responses to Link Services	60
Exchange Management	62
Sequence Management	63
Sequence Errors	64
CRC	64
Timers	65
Arbitrated Loop Timeout	65

Receiver_Transmitter Timeout	65
Error_Detect Timeout	65
Resource Allocation Timeouts	66
Resource Recovery Timeout	66
REC Timeout	66
Upper Level Protocol Timeout	66
FC-3 Common Service Features	67
FC-4 (FCP) Features	69
FCP Process Login Parameters	69
FCP Information Units	71
Command Information Unit	72
Transfer Ready Information Units	73
Data Information Unit	73
Response Information Unit	73
Response Payload	74
Response Codes	74
Task Management Flag and Information Units	77
Public Loop SCSI Target Discovery	78
Private Loop SCSI Target Discovery	78
Clearing the Effects of Fibre Channel Actions	80
Device Reservations	82
6. Command Set	85
Implementation Requirements	85
Command Descriptor Block	86
Control Byte	87
List of Supported Commands	88
Operator Entries for Fibre Channel	89
Initialize Element Status	90
Initialize Element Status With Range	91
Inquiry	92
Standard Inquiry Data Definition	93
Supported Pages Definition	95
Unit Serial Number Page Definition	96

Device Identification Page	97
Log Sense	99
Supported Pages Format page	100
Last n Errors Events Page Format	101
Informational Exceptions TapeAlert Page	102
TapeAlert Flags	103
Mode Select (6)	105
Mode Select (6) Data	106
Mode Select (6) Parameter Header	106
Fibre Channel Logical Unit Page	107
Low Voltage Differential SCSI Logical Unit Page	108
Fibre Channel Port Control Page	109
Low Voltage Differential SCSI Port Control Page	110
Informational Exceptions TapeAlert Page	111
Test Modes	112
Element Address Assignment Mode Page	113
Element Address Assignments	115
Mode Select (10)	116
Mode Select (10) Data	117
Mode Select (10) Parameter Header	117
Fibre Channel Logical Unit Page	118
Low Voltage Differential SCSI Logical Unit Page	119
Fibre Channel Port Control Page	120
Low Voltage Differential SCSI Port Control Page	121
Informational Exceptions TapeAlert Page	122
Test Modes	123
Element Address Assignment Mode Page	124
Element Address Assignments	126
Mode Sense (6)	127
Mode Sense (6) Data	129
Mode Sense (6) Parameter Header Definition	129
Fibre Channel Logical Unit Page	130
Low Voltage Differential SCSI Logical Unit Page	131

Fibre Channel Port Control Page	132
Low Voltage Differential SCSI Port Control Page	133
Informational Exceptions TapeAlert Control Page	134
Element Address Assignment Page Definition	135
Transport Geometry Mode Page Definition	137
Device Capabilities Page Definition	138
Mode Sense (10)	142
Mode Sense (10) Data	144
Mode Sense (10) Parameter Header Definition	144
Fibre Channel Logical Unit Page	145
Low Voltage Differential SCSI Logical Unit Page	146
Fibre Channel Port Control Page	147
Low Voltage Differential SCSI Port Control Page	148
Informational Exceptions TapeAlert Control Page	149
Element Address Assignment Page Definition	150
Transport Geometry Mode Page Definition	152
Device Capabilities Page Definition	153
Physical Configuration Page Definition	157
Move Medium	167
Persistent Reserve In	169
Read Keys Data	170
Read Reservations Data	171
Persistent Reserve In Data for Report Capabilities	173
Persistent Reserve Out	175
Position to Element	179
Prevent/Allow Medium Removal	180
Read Element Status	181
Read Element Status Data	182
Element Status Data Header Definition	183
Element Status Page Header Definition	184
Medium Transport Element Descriptor Definition	186
Storage Element Descriptor Definition	189
Import/Export Element Descriptor Definitions	192

Data Transfer Element Descriptor Definitions	196
Data Transfer Element Descriptor Definitions	200
Release (6)	204
Release (10)	205
Report LUNS	206
Report LUNs Data Definition	207
Request Sense	208
Sense Data	209
Request Sense Data Definitions	210
Sense Key	212
Additional Sense Codes and Qualifiers	212
No Sense Key	212
Not Ready Sense Key Codes	213
Not Ready, Cause Not Reportable	213
Not Ready, In Process of Becoming Ready	213
Not Ready, Manual Intervention Required	213
Not Ready, Maintenance Mode	213
Not Ready, Cartridge Access Port Open	213
Not Ready, Cleaning Cartridge Installed	214
Hardware Error Sense Key	214
Hardware Error, General	214
Hardware Error, Tape Drive	214
Hardware Error, CAP	214
Hardware Error, Embedded Software	215
Hardware Error, Media Load/Eject Failed	215
Illegal Request Sense Key	215
Unit Attention Sense Key	216
Power On	216
SCSI Bus Reset	216
Bus Device Reset Message	216
LUN Reset	216
Target Reset	217
Not Ready to Ready Transition	217

CAP Element Accessed	217
Mode Parameters Changed	217
Persistent Reservations/Registrations Preempted or Released	217
Microcode Has Been Changed	217
LUN Data Has Changed	217
Aborted Command Sense Key	218
Mechanical Positioning Error	218
SCSI Parity Error	218
Initiator Detected Error	218
Command Phase Error	218
Data Phase Error	218
Command Overlap	218
Request Volume Element Address	219
Volume Element Address Header Definition	221
Reserve (6)	222
Element List Descriptor Definitions	223
Other Commands and Reservations	224
Reserve (10)	225
Other Commands and Reservations	226
Send Diagnostic	227
Send Diagnostic Data	228
Diagnostic Operations	228
Send Volume Tag	229
Send Volume Tag Parameter List	230
Test Unit Ready	231
Write Buffer	232
A. Cell Maps	235
Library Walls	235
Cartridge Cell Locations – Data Cartridges	235
Cell Maps	236
Default Element Mapping	236
Diagnostic and Cleaning Cartridge Locations	239

B. Partitioning Overview	241
Partitioning—Feature	241
Partitioning—General	242
Partitioning—Access Control	242
Partitioning—Location Numbering	244
Partitioning—CAP Behavior	244
Split Assigned CAPs	244
Common Unassigned CAPs	245
Mixed CAPs	246
The CAP Button—Its Function in Partitioned Libraries	247
Partitioning—Problem Scenarios	247
Cartridge Importing	247
Cartridge Exporting	248
Partitioning—Removing the Feature	248
Partitioning—Configurations	249
Library and Tape Drive Configurations	250
Partitioning—Library Console	252

Tables

TABLE 2-1	SCSI Terminators	10
TABLE 2-2	SCSI Device Types into SCSI Bus Types	11
TABLE 3-1	Information Transfer Data	17
TABLE 3-2	Bus Signals	18
TABLE 3-3	Signal Source	19
TABLE 3-4	Messages	24
TABLE 3-5	Status Byte	28
TABLE 3-6	Reserve/Release Management Method	31
TABLE 3-7	Persistent Reservation Management Method	32
TABLE 4-1	StorageTek Library Cables and Connectors	39
TABLE 4-2	Fiber-Optic Cables: 50 μ m Multimode, SC-to-SC Connectors	40
TABLE 5-1	Fibre Channel Levels	41
TABLE 5-2	Transmission Word	42
TABLE 5-3	End of Frame Delimiters	46
TABLE 5-4	FC-AL Feature Set	50
TABLE 5-5	Library Identification Scheme	52
TABLE 5-6	Start of Frame Delimiters, Class 3	53
TABLE 5-7	Class 3 Service Parameters, Port Login	54
TABLE 5-8	Class 3 Service Parameters, Fabric Login	55
TABLE 5-9	Other FC-2 Features	56
TABLE 5-10	Basic Link Services	57
TABLE 5-11	Extended Link Services	57
TABLE 5-12	Response to Link Services from NL_Ports Not Logged-In	60
TABLE 5-13	FC-4 Link Services	60
TABLE 5-14	Exchange Content Header	62
TABLE 5-15	Sequence Content Header	63
TABLE 5-16	Timer Summary	65

TABLE 5-17	NL_Port Common Service Parameters, Port Login	67
TABLE 5-18	NL_Port Common Service Parameters, Fabric Login	68
TABLE 5-19	PRLI Parameters	69
TABLE 5-20	PRLI Accept FCP Services Parameter Page	70
TABLE 5-21	FCP 8-B byte LUN	72
TABLE 5-22	FCP_RSP Payload	74
TABLE 5-23	FCP_RSP Code	75
TABLE 5-24	Command Confirmation Usage	76
TABLE 5-25	FCP Task Management Flags	77
TABLE 5-26	FCP Task Attributes	77
TABLE 5-27	Other FCP Features	78
TABLE 5-28	Clearing Effects	80
TABLE 5-29	Reserve/Release Management Method	82
TABLE 5-30	Persistent Reservation Management Method	83
TABLE 6-1	6-Byte Command Descriptor Block	86
TABLE 6-2	10-Byte Command Descriptor Block	86
TABLE 6-3	12-Byte Command Descriptor Block	86
TABLE 6-4	Control Byte	87
TABLE 6-5	Supported Commands	88
TABLE 6-6	Initialize Element Status Command	90
TABLE 6-7	Initialize Element Status With Range Command	91
TABLE 6-8	Inquiry Command	92
TABLE 6-9	Standard Inquiry Data	93
TABLE 6-10	Supported Pages	95
TABLE 6-11	Unit Serial Number Page	96
TABLE 6-12	Device Identification Page Data	97
TABLE 6-13	Fibre Channel Device Identification	98
TABLE 6-14	Log Sense Command	99
TABLE 6-15	Supported Pages Format Page	100
TABLE 6-16	Last n Errors Events Page	101
TABLE 6-17	Informational Exceptions TapeAlert Page Format	102
TABLE 6-18	TapeAlert Flags	103
TABLE 6-19	Mode Select (6) Command	105
TABLE 6-20	Mode Select Parameter (6) Header	106
TABLE 6-21	Fibre Channel Logical Unit Page	107

TABLE 6-22	SCSI (LVD) Logical Unit Page	108
TABLE 6-23	Fibre Channel Port Control Page	109
TABLE 6-24	SCSI (LVD) Port Control Page	110
TABLE 6-25	Informational Exceptions TapeAlert Page	111
TABLE 6-26	Mode Select (6) Element Address Assignment Mode Page	113
TABLE 6-27	Mode Select (10) Command	116
TABLE 6-28	Mode Select Parameter Header	117
TABLE 6-29	Fibre Channel Logical Unit Page	118
TABLE 6-30	SCSI (LVD) Logical Unit Page	119
TABLE 6-31	Fibre Channel Port Control Page	120
TABLE 6-32	SCSI (LVD) Port Control Page	121
TABLE 6-33	Informational Exceptions TapeAlert Page	122
TABLE 6-34	Mode Select (6) Element Address Assignment Mode Page	124
TABLE 6-35	Mode Sense Command	127
TABLE 6-36	Mode Sense (6) Parameter Header	129
TABLE 6-37	Fibre Channel Logical Unit Page	130
TABLE 6-38	SCSI (LVD) Logical Unit Page	131
TABLE 6-39	Fibre Channel Port Control Page	132
TABLE 6-40	SCSI (LVD) Port Control Page	133
TABLE 6-41	Informational Exceptions TapeAlert Control Page	134
TABLE 6-42	Mode Sense (6) Element Address Assignment Page	135
TABLE 6-43	Transport Geometry Mode Page	137
TABLE 6-44	Device Capabilities Page	138
TABLE 6-45	Mode Sense (10) Command	142
TABLE 6-46	Mode Sense Parameter Header Page	144
TABLE 6-47	Fibre Channel Logical Unit Page	145
TABLE 6-48	SCSI (LVD) Logical Unit Page	146
TABLE 6-49	Fibre Channel Port Control Page	147
TABLE 6-50	SCSI Port Control Page	148
TABLE 6-51	Informational Exceptions TapeAlert Control Page	149
TABLE 6-52	Element Address Assignment Page	150
TABLE 6-53	Transport Geometry Mode Page	152
TABLE 6-54	Device Capabilities Page	153
TABLE 6-55	Physical Configuration Page	158
TABLE 6-56	Module Type Definitions	165

TABLE 6-57	Move Medium Command	167
TABLE 6-58	Persistent Reserve In Command	169
TABLE 6-59	Read Keys Data	170
TABLE 6-60	Read Reservations Data	171
TABLE 6-61	Reservation Descriptors Format	172
TABLE 6-62	Persistent Reserve In Parameter Data for Report Capabilities	173
TABLE 6-63	Read Reservations Parameter Data	174
TABLE 6-64	Persistent Reserve Out Command	175
TABLE 6-65	Persistent Reserve Out Parameter List	177
TABLE 6-66	Persistent Reserve Out Service Actions and Valid Parameters	178
TABLE 6-67	Service Action Reservation Key Information	178
TABLE 6-68	Position to Element Command	179
TABLE 6-69	Prevent/Allow Medium Removal Command	180
TABLE 6-70	Read Element Status Command	181
TABLE 6-71	Element Status Data Header Definition	183
TABLE 6-72	Element Status Page Header	184
TABLE 6-73	Medium Transport Element Descriptor	186
TABLE 6-74	Storage Element Descriptor	189
TABLE 6-75	Import/Export Element Descriptor	192
TABLE 6-76	Data Transfer Element Descriptor When DvcID = 0	196
TABLE 6-77	Data Transfer Element Descriptor When DvcID = 1	200
TABLE 6-78	Release Command (6)	204
TABLE 6-79	Release (10) Command	205
TABLE 6-80	Report LUNs Command	206
TABLE 6-81	Report LUNs Data	207
TABLE 6-82	LUN Descriptor	207
TABLE 6-83	Request Sense Command	208
TABLE 6-84	Request Sense Data	210
TABLE 6-85	Sense Key Code Descriptions	212
TABLE 6-86	Not Ready Sense Keys	213
TABLE 6-87	Hardware Error Sense Keys	214
TABLE 6-88	Illegal Request Sense Keys	215
TABLE 6-89	Unit Attention Sense Keys	216
TABLE 6-90	Aborted Command Sense Keys	218
TABLE 6-91	Request Volume Element Address Command	219

TABLE 6-92	Volume Element Address Header	221
TABLE 6-93	Reserve Command	222
TABLE 6-94	Element List Descriptor	223
TABLE 6-95	Reserve (10) Command	225
TABLE 6-96	Send Diagnostic Command	227
TABLE 6-97	Send Diagnostic Data	228
TABLE 6-98	Send Volume Tag Command	229
TABLE 6-99	Send Volume Tag Parameter List	230
TABLE 6-100	Test Unit Ready Command	231
TABLE 6-101	Write Buffer Command	232
TABLE A-1	First and Last Element Addresses	236
TABLE A-2	Slot Counts for Different Configurations	239
TABLE B-1	CLI Commands for Library Configuration	250
TABLE B-2	CLI Commands for Tape Drive Configuration	251

Preface

This manual is intended for independent software vendors (ISVs), operating system designers and developers, hardware engineers, and software engineers responsible for implementing the Sun StorageTek version of the small computer system interface (SCSI) or Fibre Channel interface (FC) for the SL500 modular library system (referred to in this manual as “the SL500 library,” or “the library”).

This manual contains information about the small computer system interface, including SCSI characteristics, library features, SCSI bus operations, SCSI commands, status byte data, and sense data. This manual also contains information about the Fibre Channel interface, including Fibre Channel operations, command implementations, topologies, cables, and connectors.

Note – This manual *does not* describe the SCSI bus controls and commands or the Fibre Channel operations and commands for the *tape drives* in the library.

Organization

This manual contains six chapters, two appendixes, a glossary, and an index:

Chapter 1	“General Information” contains a high-level overview about the small computer system interface and the Fibre Channel interface.
Chapter 2	“SCSI Bus Physical Description” describes both the single-ended and differential alternatives for the interface attachments.
Chapter 3	“SCSI Bus Operations” explains the seven elements that the small computer system interface uses for controlling the interface, transferring data, issuing commands, and returning status.
Chapter 4	“Fibre Channel Physical Interface” explains the ports, topologies and cable requirements for Fibre Channel.
Chapter 5	“Fibre Channel Operations” explains the structure of the Fibre Channel standard and its implications for library operation in an arbitrated loop topology.
Chapter 6	“Command Set” lists and defines the commands for the library.
Appendix A	“Cell Maps” shows the cell mappings and configurations for the library.
Appendix B	“Partitioning Overview” describes the partitioning feature for the SL500 library.

Alert Messages

Alert messages call your attention to information that is especially important or that has a unique relationship to the main text or graphic.

Note – A note provides additional information that is of special interest. A note might point out exceptions to rules or procedures. A note usually, but not always, follows the information to which it pertains.

Related Publications

For your convenience, the following sections list publications that provide information about the interfaces and libraries mentioned in this manual.

Listed publications are subject to change without notice.

Publication	Part Number
<i>American National Standard Dictionary for Information Processing Systems</i>	X3/TR-1-82
<i>SCSI-3 Primary Commands (SPC)</i>	X3.301-1997
<i>SCSI-3 Primary Commands (SPC-2)</i>	T10/Project 1236D
<i>SCSI-3 Medium Changer Commands (SMC)</i>	T10/Project 1383D
<i>SCSI-3 Architecture Model (SAM)</i>	X3.270-1996
<i>SCSI Architecture Model – 2 (SAM-2)</i>	T10/Project 1157D
<i>VIPER 2000 LTO Tape Drive SCSI Reference Manual</i>	T001
<i>VIPER 2000 LTO Tape Drive SCSI Reference Manual</i>	10006952-XXX
<i>SCSI Parallel Interface (SPI-5)</i>	T10/Project 1525D
<i>Fibre Channel Physical and Signaling Interface (FC-PH)</i>	X3.230-1994 Revision 4.3 X3.230-1996 (Amendment 1) X3.230-1997 (Amendment 2)
<i>Fibre Channel Physical and Signaling Interface (FC-PH-2)</i>	X3.297-1996 Revision 7.4
<i>Fibre Channel Physical and Signaling Interface (FC-PH-3)</i>	X3.303-199x Revision 9.3
<i>Fibre Channel Arbitrated Loop (FC-AL)</i>	X3.272-1996 Revision 4.5
<i>Fibre Channel Arbitrated Loop (FC-AL-2)</i>	X3.272-199x Revision 7.0
<i>Fibre Channel Protocol for SCSI (FCP)</i>	X3.269-1996 Revision 12
<i>Fibre Channel Protocol for SCSI (FCP-2)</i>	T10/Project 1144D Revision 01
<i>Fibre Channel Tape (FC-Tape)</i>	NCITS TR-XX Revision 1.17

Additional Information

Sun Microsystems, Inc. (Sun) offers several methods for you to obtain additional information.

Sun's External Web Site

Sun's external Web site provides marketing, product, event, corporate, and service information. The external Web site is accessible to anyone with a Web browser and an Internet connection.

The URL for the external Web site is: <http://www.sun.com>

Partners Site

The StorageTek Partners site is a Web site for partners with a StorageTek Partner Agreement. This site provides information about products, services, customer support, upcoming events, training programs, and sales tools to support StorageTek Partners. Access to this site, beyond the Partners Login page, is restricted. On the Partners Login page, employees and current partners who do not have access can request a login ID and password and prospective partners can apply to become StorageTek resellers.

The URL for partners with a Sun Partner Agreement is:
<http://www.sun.com/partners/>

Hardcopy Publications

Contact a Sun StorageTek representative for additional copies of this manual or other Sun StorageTek publications.

Safety

Fiber-optic Safety

Warning – Possible Physical Injury.

- *Eye hazard.* Never look directly into a fiber-optic cable, a fiber-optic connector, or a laser transceiver module. Hazardous conditions might exist from laser power levels that are capable of causing injury to your eyes.
- Be especially careful when you use optical instruments with this equipment. Such instruments might increase the likelihood of injury to your eyes.
- *Radiation exposure.* Use of controls or adjustment or performance of procedures other than those specified herein might result in hazardous radiation exposure.

The laser transceivers in fiber-optic equipment can pose dangers to personal safety. Ensure that anyone who works with this Sun StorageTek equipment understands these dangers and follows safety procedures. Ensure that the optical ports of every laser transceiver module are terminated with an optical connector, a dust plug, or a cover.

Each fiber-optic interface in this Sun StorageTek Fibre Channel equipment contains a laser transceiver that is a Class 1 Laser Product. Each laser transceiver has an output of less than 70 μ W. Sun StorageTek Class 1 Laser Products comply with EN60825-1:1994+A1+A2 and with sections 21 CFR 1040.10 and 1040.11 of the Food and Drug Administration (FDA) regulations.

The following translations are for users in Finland and Sweden who wish to identify laser safety and classification:

CLASS 1 LASER
LUOKAN 1 LASERLAITE
KLASSE 1 LASER APPARAT

Laser Product Label

In accordance with safety regulations, a label on each Sun StorageTek Fibre Channel product identifies the laser class of the product and the place and date of the manufacturer. The label appears on top of a Fibre Channel tape drive and near the Fibre Channel connectors on a Fibre Channel tape library. A copy of the label is shown here:

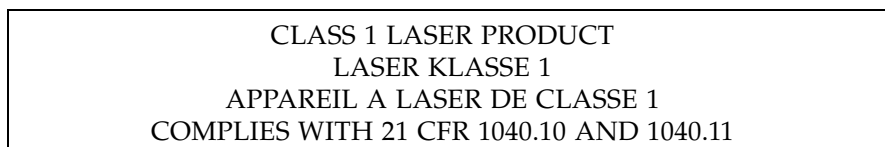

Fiber-optic Cable Installation

Follow these guidelines when you install fiber-optic cables:

1. Cable routing:

- **Raised floor:** You may install fiber-optic cables under a raised floor. Route them away from any obstruction, such as existing cables or other equipment.
- **Cable tray or raceway:** Place the cables in position; do not pull them through the cable tray. Route the cables away from sharp corners, ceiling hangers, pipes, and construction activity.
- **Vertical rise length:** Leave the cables on the shipping spool, and lower them from above; do not pull the cables up from below. Use proper cable ties to secure the cable.
- **General:** Do not install fiber-optic cables on top of smoke detectors.

2. Cable management:

- Leave at least 4.6 m (15 ft) of cable at each end for future growth.
- Use strain reliefs to prevent the weight of the cable from damaging the connector.
- Review all information in this manual and in any related manuals about safely handling fiber-optic cables.

3. Connector protection:

- Insert connectors carefully to prevent damage to the connector or fiber.
- Leave the connector's protective cover in place until you are ready to make connections.
- Replace the connector's protective cover when the connector is disconnected.
- Clean the connector before making a connection. Make sure that there are no obstructions and that keyways are aligned.

Fiber-optic Cable Handling

Observe these precautions when you handle fiber-optic cables:

- Do not coil the cable to less than 96 mm (3.75 in.) in diameter.
- Do not bend the cable to less than 12 mm (0.5 in.) in radius. StorageTek recommends that a cable's bend radius be no less than 20 times the diameter of the cable.
- Do not pull on the cables; carefully place them into position.
- Do not grasp the cables with pliers, grippers, or side cutters; do not attach pulling devices to the cables or connectors.
- Keep cables away from sharp edges or sharp protrusions that could cut or wear through the cable; make sure that cutouts in the equipment have protective edging.
- Protect the cable from extreme temperature conditions.
- Install the connector's protective cover whenever the connector is not connected.

General Information

This chapter describes the small computer system interface (SCSI) and the Fibre Channel interface (FC) for the SL500 tape library. This manual does not describe the Fibre Channel interface to the tape drives.

The SCSI Bus Interface

The libraries' SCSI interface conforms to SCSI specifications and is accepted by:

- American National Standards Institute (ANSI X3.131)
- European Computer Manufacturing Association (ECMA-111)
- Federal Information Processing Standard (FIPS-131)
- International Standards Organization (ISO-9316)

Overview

The small computer system interface operates locally as an input and output (I/O) bus that uses a common command set to transfer controls and data to all devices. The main purpose of this interface, called the SCSI bus, is to provide host computer systems with connections to a variety of peripheral devices, including disk subsystems, tape subsystems, printers, scanners, CD-ROMs, optical devices, communication devices, and libraries.

The SCSI bus design for the library provides a peer-to-peer, I/O interface that supports up to 16 devices and accommodates two hosts.

Peer-to-peer interface communication can be from:

- Host to host
- Host to peripheral device
- Peripheral device to peripheral device

SCSI terms defining communication between devices on the SCSI bus include:

- *Initiator* is the device that requests an operation.
- *Target* is the device that performs the operation requested.

Some targets are control units that can access one or more physical or virtual peripheral devices addressable through the control unit. These peripheral devices are called logical units and are assigned specific addresses or logical unit numbers (LUNs).

The library supports SCSI-3 commands using LUN 0.

The library and the tape drives have separate connections for attachment to the SCSI bus. Daisy-chain cables are available to interconnect devices on the SCSI bus but keep the total cable length to a minimum. **FIGURE 1-1** is an example of a library and four tape drives that are daisy-chained to two initiators (or hosts).

Note – It is recommended that the drives be connected to a separate SCSI bus from the library.

FIGURE 1-1 Example of a Library Configuration on the SCSI Bus

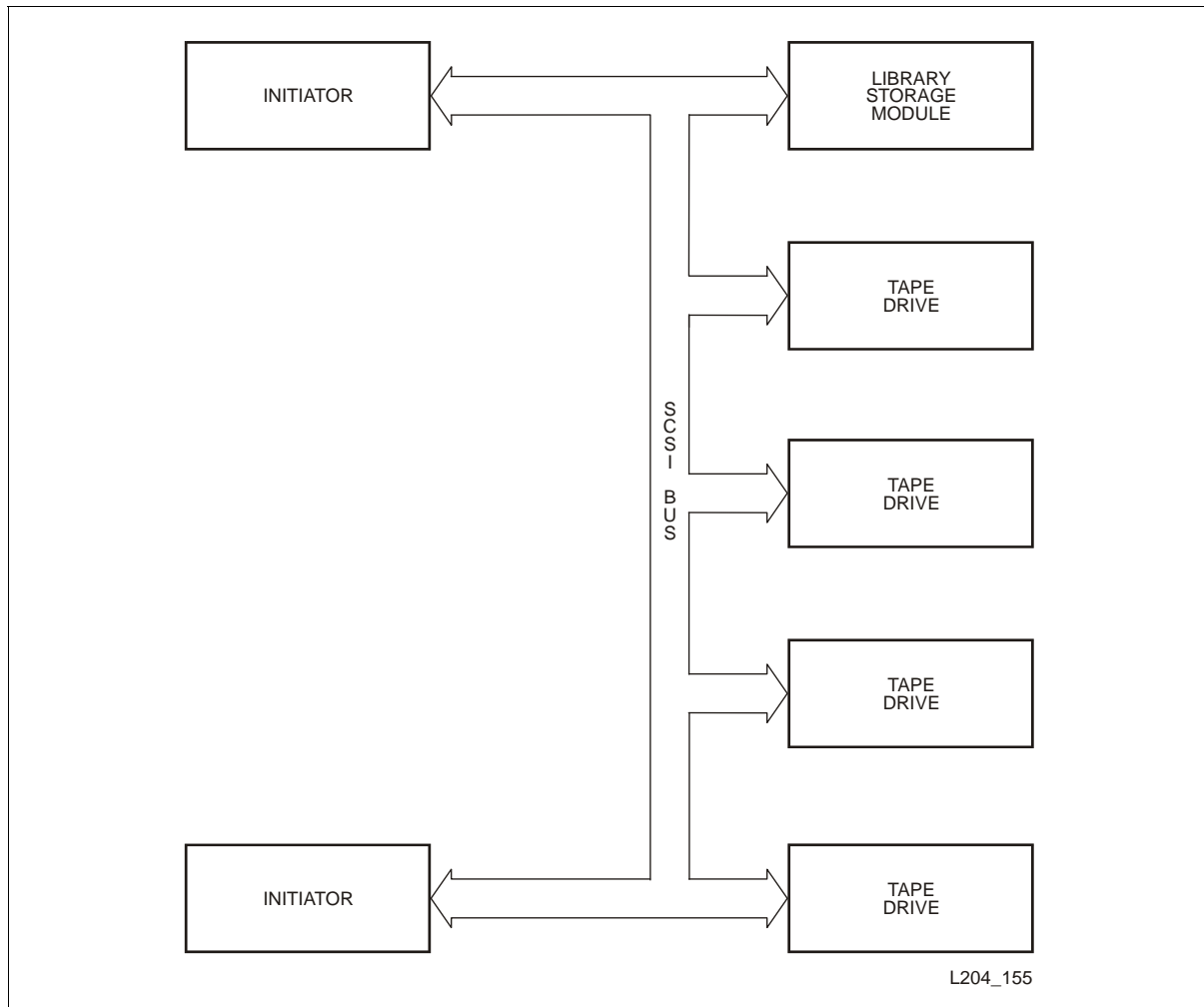

Benefits

FIGURE 1-1 is an example of a multi-initiator, multi-target configuration using a library and four tape drives.

A small computer system interface also provides these benefits:

- Low overhead
- High transfer rates
- A high-performance buffered interface
- Conformance to industry standards
- Plug compatibility for easy integration
- Error recovery, parity, and sequence checking provides high reliability
- Provisions in the command set for vendor-unique fields
- Standard or common command sets with an intelligent interface that provides device independence

The SCSI bus uses seven elements for interface control, data transfer, commands, and status. [Chapter 3, “SCSI Bus Operations,”](#) explains each of these elements in more detail.

Implementation

Implementation of the SCSI bus for the library supports:

- 8-bit wide transfers, asynchronous; 16-bit wide selection
- Disconnect and reselect
- Multiple initiator
- Hard resets
- Single-ended LVD
- SCSI-3, 68-pin P-cable

Implementation for the library *does not* support:

- Soft resets
- Command queuing
- Command linking
- Asynchronous event notification
- Extended contingent allegiance

The Fibre Channel Standard

The Sun StorageTek implementation of Fibre Channel conforms to the American National Standards Institute (ANSI), National Committee for Information Technology Standards (NCITS) formerly X3.

Overview

- Serial connection
- Copper (electrical) or fiber (optical) transmissions
- Multiple Initiator Support
- Information transparent
- 100 MB/s data transfer rates (and higher)
- Scalable for media rates, distance, media, and protocols

Benefits

In 1994, the Fibre Channel Physical and Signaling Interface (FC-PH), or ANSI X3.230-1994, was completed, differing from every other architecture at the time. This specification married the strengths of channels, including high throughput and low overhead, with the strengths of networks, including flexibility, long distance capability, and high connectivity.

Implementation

Library:

- Arbitrated loop
- FCP (SCSI-3) command set for medium changer devices
- Class 3 level of service
- Private Loop operation
- Public Loop operation
- Direct fabric attach operation
- Hard-assigned port addresses (AL-PA)
- Basic and extended link services
- Connections to an external hub (or switch)
- Data transfer rates of 100 MB/s
- Standard approved length shortwave fibre optic cables
- Multimode laser operating at 780 nanometers (shortwave) non-OFC

Hub:

- Multiple ports
- Standard approved length fibre optic and copper cables
- Multimode laser operating at 780 nanometers (shortwave) non-OFC
- Single mode laser operating at 1300 nanometers (longwave)
- Cascading hub attachments
- Gigabit Interface Converter (GBIC) connections in the hub

Note – See [Chapter 4, “Fibre Channel Physical Interface,”](#) for more information about the hubs, cables, and connectors.

Switch:

- Attachment to FL_Ports is supported.

SCSI Bus Physical Description

This chapter contains the physical description for the small computer system interface (SCSI) bus for the SL500 library, including:

- Characteristics
 - Interface cables
 - Special signals
 - P-cable to A-cable adapters
-

Characteristics

The library supports single-ended/LVD (low-voltage differential) for the SCSI bus connection. The following paragraphs describe the characteristics for these alternatives.

The single-ended alternative has the following characteristics:

- Maximum cable length of 3 m (9.8 ft)
- Minimum cable length of 0.3 m (1 ft)
- Primarily for connections within a cabinet
- 0.1 m (4 in.) stubs (the distance from the on-board device to the bus)
- Twisted-pairs cables (sometimes)
- Less power than the differential alternative
- Low cost
- Lower performance data rates than LVD

The LVD alternative has the following characteristics:

- Maximum cable length of 12 m (39.4 ft)
- Minimum cable length of 0.36 m (14.2 in.)
- 0.1 m (4 in.) stubs (the distance from the on-board device to the bus)
- Usable for outside cabinet connections
- LVD- or Universal-rated cables

SCSI Options

Note – You can use the Configuration menu from Library Console, to check the valid SCSI bus connections. The screen that displays the SCSI ID of the library should indicate either single-ended or differential. If the screen displays “Invalid Configuration,” you have mixed single-ended devices with differential devices somewhere on the bus. Correct the bus connection; then use the feature to verify the bus connection.

The MPW/RLW plugs into the RLC. The transfer sizes and syncs may be supported.

Interface Cables

The cable that attaches devices to the SCSI bus is very important. Marginal quality cables can cause intermittent parity errors and might corrupt data during transfer.

We recommend SCSI cables that have these general characteristics:

- Twisted pairs (two insulated wires twisted together) to help eliminate noise and crosstalk
- Discrete lines for the asserted and negated version of each signal
- Shielding that provides an impedance rating that matches the requirement for the SCSI alternative:
 - 84 Ω nominal for single-ended
 - 110 Ω to 135 Ω for LVD

Caution – *Potential interference:* To minimize discontinuities and signal reflections, do not mix cables of different impedances on the same bus. *Stringent LVD requirements:* Because of stringent requirements for LVD cable impedance-matching, you must use only LVD-specified cables or universal cables with LVD specifications for all LVD applications.

- A 26 to 30 American Wire Gauge (AWG) conductor to minimize the effects of noise on the bus and to ensure proper distribution of terminator power (when terminator power is required).

Note – The Terminator Power jumper on the LLC card in the library is selectable and is normally set to ON.

The style of the cable, flat or round, does not matter.

The library supports the following cable types and specifications:

Cable Type	Description
P-cable	The SCSI-3 P-cable consists of 68 conductors: 16 data lines 9 control lines 2 parity lines 7 ground, reserved, or special signal lines
A-cable	The SCSI-2 A-cable consists of 50 conductors: 8 data lines 9 control lines 1 parity lines 7 ground, reserved, or special signal lines

Note – If the SCSI bus uses an A-cable, you must use an adapter to terminate the eight additional data lines in the P-cable. You then must use the P-cable to connect the SCSI bus to the library and tape drives.

External

StorageTek supplies a variety of external SCSI bus cables to connect the library and tape drives to the SCSI bus. Types of cables include:

- 50-pin Centronics
- 68-pin Micro D-type
- 68-pin micro-centronix
- 68-pin AS/400 recessed hardware
- 68-pin RS6000 (2416 IOP)
- 68-pin 4-40 hardware

Contact a marketing representative or refer to the system assurance guide for your library for information about SCSI cables.

Daisy-Chain

The library and the tape drives may be daisy chained on the SCSI bus using short SCSI cables. The library and the tape drives each have two SCSI connectors wired in parallel. To daisy chain these devices, connect a SCSI cable from the bus to one of the connectors; then connect a SCSI daisy-chain cable from the other connector to the next device. Daisy-chain cables are available from StorageTek.

Note – If a device is first or last on the SCSI bus, then it must be terminated. See [“Terminator” on page 10](#) for information and part numbers.

Connector

The SCSI connector for the library and the tape drives is a high-density (HD), shielded, 68-pin, D-type connector for P-cable attachments.

Terminator

You must terminate all SCSI signals at *each* end of the SCSI bus by connecting a terminator to one of the SCSI connectors on the device at each end of the SCSI bus. [TABLE 2-1](#) lists the terminators for the single-ended, and LVD alternative as well as the adapter:

TABLE 2-1 SCSI Terminators

Part Number	Description
10148002	68-pin, fast/narrow single-ended
10097653	68-pin LVD-SE multi-mode (actively switches between LVD and single-ended mode)

Special Signals

The library supports two special SCSI bus signals:

- Differential Sense (DIFFSENS)
- Terminator Power (TERMPWR)

Differential Sense

The differential sense (DIFFSENS) is a DC voltage level that distinguishes among the two SCSI alternatives: single-ended, and LVD:

Single-ended: -0.35 V to +0.5 V

LVD: +0.7 V to +1.9 V

The DIFFSENS signal helps prevent damage to the SCSI bus and other equipment when the SCSI device is incompatible with the SCSI bus. Some potential for device damage still exists, however, depending on the type of incompatibility. The following table (TABLE 2-2) shows the effects of different types of incompatibility.

TABLE 2-2 SCSI Device Types into SCSI Bus Types

If you plug this device type into this SCSI bus type . . .	Single-Ended (SE) Bus	LVD Bus
Single-ended (SE) device	No effect. This is a proper connection.	The entire bus will run in SE mode (with SE restrictions).
LVD device	The LVD device will run in SE mode.	No effect. This is a proper connection.

Terminator Power

The library is capable of providing terminator power on the SCSI bus. All devices supporting the differential alternative (LVD) must have the ability to provide terminator power (TERMPWR) with the following characteristics:

Note – Industry standards dictate that no more than three devices should provide terminator power on the bus. This ensures that voltage on the bus stays high (+5 VDC) without over-driving the signal or overloading the bus.

Jumpers on the library enable terminator power.

P-cable to A-cable Adapter

Problems can occur when you mix SCSI devices that use P-cables with devices that use A-cables:

- The terminator power (TERMPWR) requirements for devices using a P-cable have been increased to support a 16-bit data bus. Devices using an A-cable and supporting the SCSI-1 standard may not supply sufficient TERMPWR to operate on the SCSI bus.

Two reserved lines on the A-cable (23 and 24) must provide TERMPWR to P-cable lines (33 and 34).

- When buses of different widths are connected on the same bus, data bus signals from wider cables are left open and must be terminated using an adapter.

When connecting a P-cable to an A-cable for eight-bit (narrow) data transfers, the following signals are left open. A special adapter must terminate these signals:

- +DB (15-8)
- +DB (P1)
- -DB (15-8)
- -DB (P1)

The adapter is part number 10148010.

See [FIGURE 2-1](#) for an example of this adapter and the terminated signals.

FIGURE 2-1 A-cable to P-cable Adapter

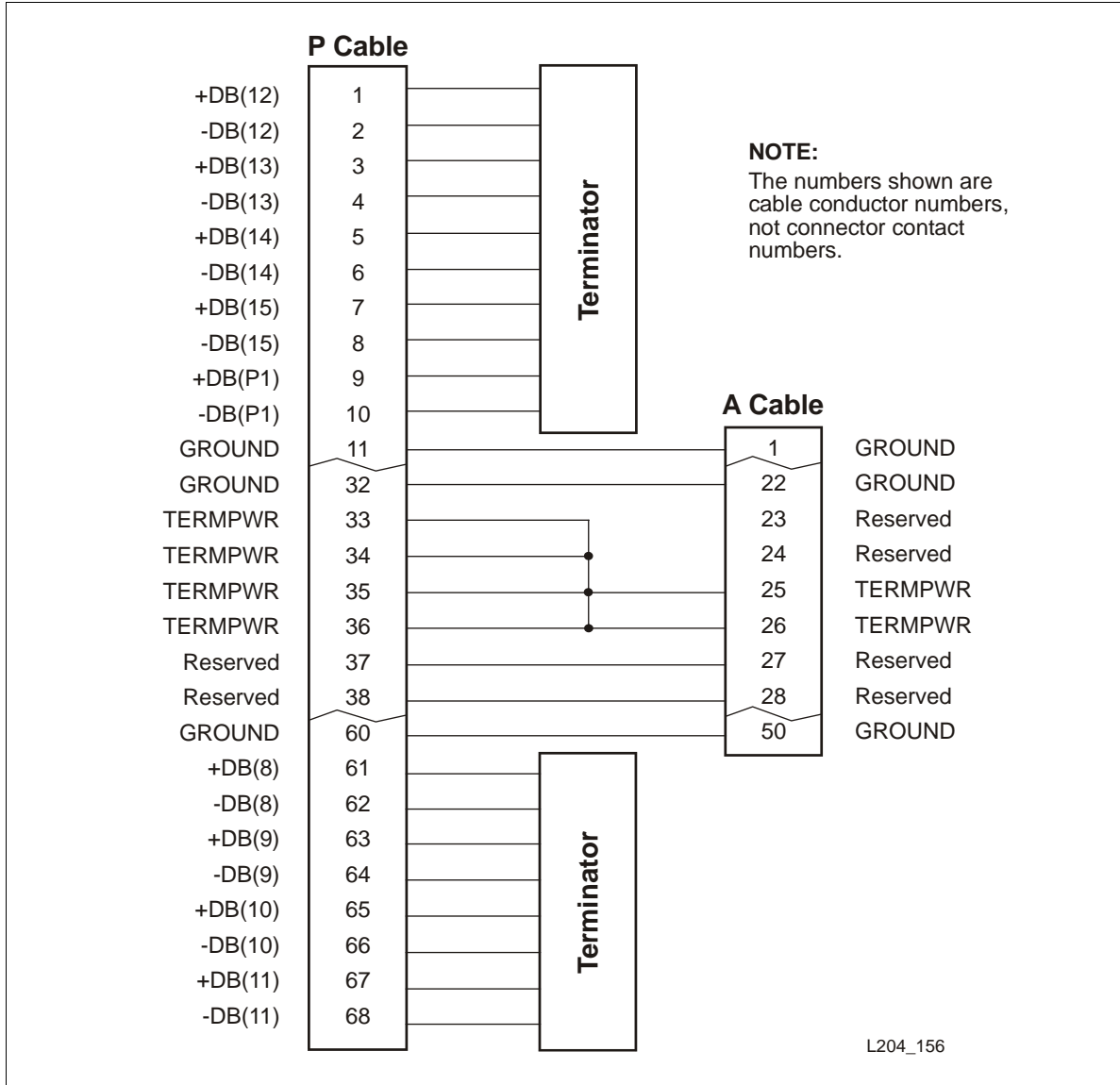

SCSI Bus Operations

This chapter describes the seven elements that SCSI uses for controlling the interface, transferring data, issuing commands, and returning status for the SL500 library:

- Bus phases
 - Bus signals
 - Bus conditions
 - Pointers
 - Messages
 - Commands
 - Status byte
-

Bus Phases

The SCSI bus uses eight states, called bus phases, to establish and control connections between the initiator and the target:

- Bus Free
- Arbitration
- Selection
- Reselection

Information Transfer phases:

- Message (in or out)
- Command
- Data (in or out)
- Status

Each bus phase is governed by a predetermined set of rules established by SCSI.

Note – The SCSI bus can only be in *one* phase at a time.

The SCSI bus follows a specific sequence to go from one phase to another, shown in [FIGURE 3-1](#).

FIGURE 3-1 SCSI Bus Phases

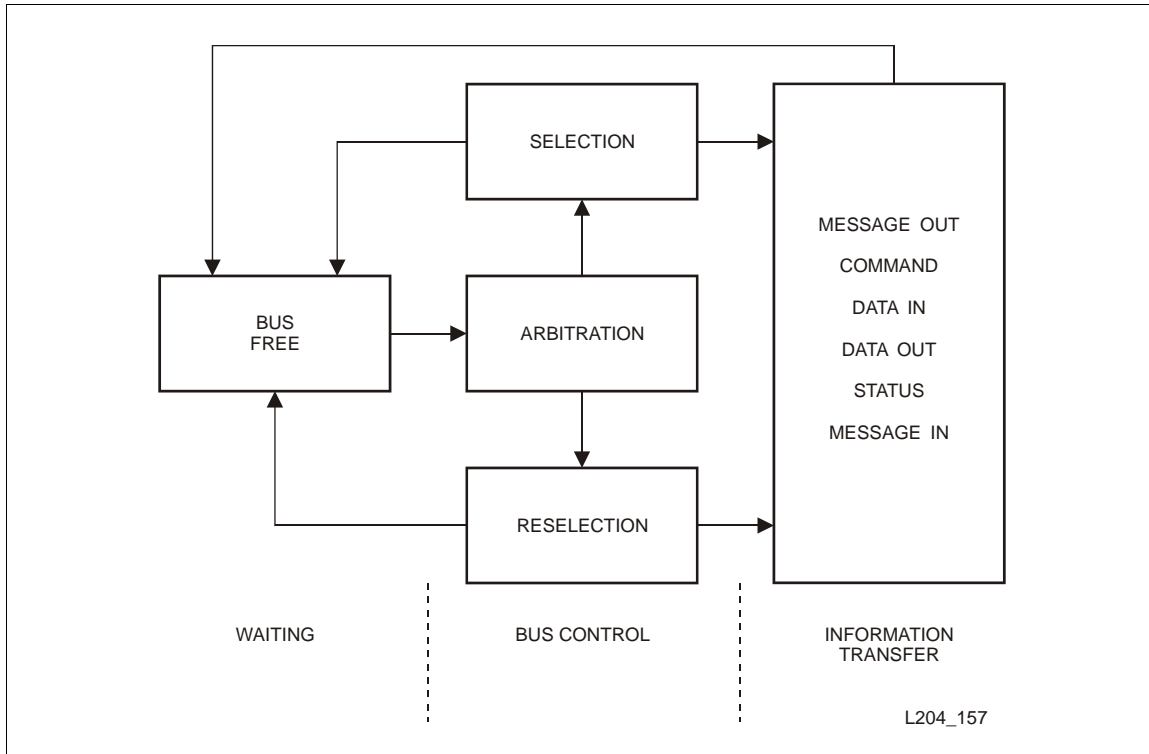

The normal progression of the SCSI bus is from:

1. Bus Free phase to the Arbitration phase
2. Arbitration phase to the Selection or Reselection phase
3. Selection or Reselection phase to one or more of the Information Transfer phases
4. Information Transfer phases to the Bus Free phase

Notes:

1. At any time, any phase can be followed by the Bus Free phase.
2. There are no restrictions on the sequences in the Information Transfer phase. Any Information Transfer phase can be followed by the same phase or any other Information Transfer phase.
3. A Reset condition can abort any phase and is always followed by the Bus Free phase.

Bus Free

During the Bus Free phase, the SCSI bus is available for use by any device (initiator or target) connected to it.

Arbitration

The Arbitration phase allows an initiator (or target during reselection) to gain control of the SCSI bus. All devices requiring use of the bus assert their SCSI IDs to gain control. If multiple devices attempt to gain control of the bus at the same time, the device with the highest-priority SCSI ID obtains control over the bus.

Selection

The Selection phase allows an initiator to select a target to perform some operation. In the Selection phase, the initiator asserts both its SCSI ID and the SCSI ID of the target being selected on the bus. This selection process informs the device that it is being selected and identifies the initiator that is performing the selection.

Reselection

The Reselection phase allows the target to reconnect to an initiator after disconnecting.

Information Transfer

Four Information Transfer phases transfer data or provide status over the SCSI bus:

TABLE 3-1 Information Transfer Data

Command	The Command phase allows the device to request command information from the initiator.
Data	Two types of Data phases transfer data in asynchronous modes:
Data In	The target sends data to the initiator.
Data Out	The initiator sends data to the target.
Message	There are two types of Message phases:
Message In	The target sends messages to the initiator.
Message Out	The target receives messages from the initiator. The target invokes this phase when the initiator asserts the attention (ATN) signal.
Status	The Status phase allows the target to send status information to the initiator.

Bus Signals

Communication between two devices on the SCSI bus occurs any time after they establish connection using the bus phases. When two devices communicate, one device acts as an *initiator* and the other device acts as a *target*.

FIGURE 3-2 shows the source and direction of the SCSI bus signals.

TABLE 3-2 Bus Signals

BSY	Busy is a control signal that indicates the SCSI bus is in use.
SEL	Select is a control signal that selects a target or initiator.
C/D	Control and Data signals are driven by the target to indicate whether control or data information is being transferred.
I/O	Input and Output are control signals driven by the target to control the direction data travels on the bus (with respect to the initiator).
MSG	Message is a control signal driven by the target.
REQ	Request is a control signal driven by the target to indicate a request for a REQ/ACK data transfer handshake.
ACK	Acknowledge is a control signal driven by an initiator to indicate an acknowledgment for a REQ/ACK data transfer handshake.
ATN	Attention is a control signal driven by an initiator to indicate an Attention condition.
RST	Reset is a control signal that generates a Reset condition when asserted.
DB(0-n)	Data bus signals (0-n) transfer data where <i>n</i> indicates the number of data bus signals.
DB(P,P1)	Data bus parity signals (P,P1) are undefined during the Arbitration phase and are defined as <i>odd</i> parity during data transfer.

FIGURE 3-2 Signal Source and Direction

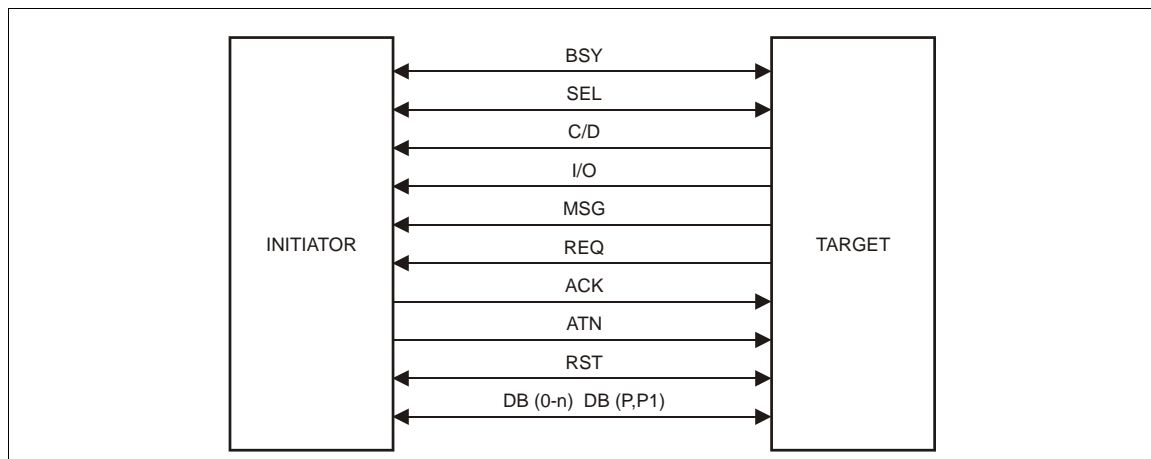

Signal Sources

TABLE 3-3 indicates the source and phase of the SCSI bus signals.

TABLE 3-3 Signal Source

Bus Phase	Bus Signals				
	BSY	SEL	C/D I/O MSG REQ	ACK ATN	DB
Bus Free	N	N	N	N	N
Arbitration	A	W	N	N	ID
Selection	I & T	I	N	I	I
Reselection	I & T	T	T	I	I
Command	T	N	T	I	I
Data In	T	N	T	I	T
Data Out	T	N	T	I	I
Status	T	N	T	I	T
Message In	T	N	T	I	T
Message Out	T	N	T	I	I

Notes:

A	The signal is driven by all SCSI devices <i>arbitrating</i> .
I	If this signal is driven, it is driven only by the active <i>initiator</i> .
ID	A unique data bit (the SCSI <i>ID</i>) is driven by each SCSI device that is arbitrating. The other 15 data bits are released (not driven) by this SCSI device. The parity bit DB(P, P1) may be driven or undriven to the asserted state but will never be driven to the negated state during this phase.
I&T	The signal is driven by the <i>initiator</i> , <i>target</i> , or <i>both</i> , as specified in the Selection and Reselection phases.
N	The signal is released—that is, <i>not driven</i> —by any SCSI device. The bias circuitry of the bus terminators pulls the signal to the negated state.
T	If the signal is driven, it is driven only by the active <i>target</i> .
W	The signal is driven by the device that <i>wins</i> during the arbitration phase.

Bus Conditions

SCSI uses bus conditions to interrupt operations and to handle errors. These conditions cause a SCSI device to accomplish certain actions by altering the bus phase sequence.

The library supports five types of bus conditions:

- Attention
- Parity Errors
- Reset
- Contingent Allegiance
- Unit Attention

Example: A device has a problem executing a command or something happens to that device during an I/O operation, such as a device reset. In this case, a Contingent Allegiance condition is flagged to indicate to the initiator that a problem exists with the device.

Attention

The Attention condition allows an initiator to inform a device that a message is ready for transfer. The target obtains this message by going to the Message Out phase.

The initiator creates the Attention condition by asserting the ATN signal on the SCSI bus any time, except during the Arbitration or Bus Free phases.

Parity Errors

A Parity Error condition occurs if the target detects one or more parity errors in the message bytes received. The target retries the message by asserting the REQ signal after detecting the negated ATN signal and before changing to another bus phase. When the initiator detects this condition, it resends the message bytes in the same order as before.

If a parity error occurs during Command Out, Data Out, or Status In, the target sends a "Restore Pointers" message to the initiator and retries the command, data, or status phase.

Reset

The library recognizes three types of resets. It implements the SCSI hard reset alternative and the Bus Device Reset message. In addition, the library generates an implicit reset when the library is powered on.

When a reset condition is detected, the library performs these actions:

- Clears all I/O processes and discontinues any current command in progress.
- Clears logical unit and element reservations, except for persistent reservations, for all initiators.
- Sets the parameters for mode page 1Dh to the saved values (or to the default values if the saved values are in error).

Upon completion of a reset condition, the library generates a Unit Attention to all initiators to indicate that a reset occurred.

Contingent Allegiance

The target—the library or a drive—generates a Contingent Allegiance Condition for the initiator that caused the error after:

- The target returns a Check Condition status because it has detected an error, failure or other exception condition
- An unexpected, optional disconnect occurs between the target and the initiator. (In other words, the target unexpectedly returns to the Bus Free phase.)

When the target generates a Contingent Allegiance Condition, a series of activities occurs:

- The target preserves the sense data in case it is requested by the initiator.
- If the next command from the initiator to the target (following the Contingent Allegiance Condition) is Request Sense, the target returns the sense data. If the target receives any command other than Request Sense, the sense data is lost and the target processes the command.

Unit Attention

The Unit Attention Condition is a specific form of the Contingent Allegiance Condition. The target generates a Unit Attention condition for each initiator for:

- A hard reset condition
- A power-on reset
- A SCSI Bus Device Reset message

Example: A library is installed on the SCSI bus, but the library is powered off. When powering-on, the library generates a Unit Attention condition to all initiators attached to the SCSI bus. The initiator must clear the Unit Attention condition before communication with the library can occur.

A target also generates a Unit Attention condition for:

- Changing the removable medium
- Changing the Mode Select parameters
- Preempting Persistent Reservations

The Unit Attention condition persists for each initiator until that initiator issues a command to the target or logical unit (other than Request Sense or Inquiry commands) for which the device returns a Check Condition status.

- If the next command from that initiator to the logical unit (following the Check Condition status) is Request Sense, the Unit Attention sense key is returned. If the target receives any command other than Request Sense, the Unit Attention condition is lost.
- If the target receives an Inquiry command from an initiator with a pending Unit Attention condition (before the device reports Check Condition status), the device completes an Inquiry command and does not clear the condition.
- If the target receives a Request Sense command from an initiator with a pending Unit Attention condition (before the device reports Check Condition status), the device reports any pending sense data and preserves the unit attention condition.
- If an initiator issues a command other than Inquiry or Request Sense while a Unit Attention condition exists for that initiator, the device returns Check condition status with the Unit Attention sense key and clears the Unit Attention condition.

Pointers

SCSI uses pointers to indicate the relative locations in memory of the initiator. The SCSI pointer architecture has two elements:

Current	The current element points to the next byte of information to be transmitted. This set of pointers is shared by all devices.
Saved	The saved element points to the beginning or initial I/O block being transmitted. There is one set of saved pointers for each <i>active</i> I/O process.

Each pointer element has three pointers for each I/O process:

Command	The command pointer indicates the start of the command descriptor block.
Data	The saved data pointer indicates the start of the data area. If the target issues a Save Pointer Message during that I/O process, the initiator updates and stores the new value in the saved data pointer.
Status	The status pointer indicates the start of the status area.

The following explains how pointers are used during the I/O process:

Example: Because a device needs time to process commands or multiple data blocks, the target disconnects from the initiator to free the SCSI bus for other operations.

The target directs the initiator to save data pointers by sending a Save Data Pointer message before disconnection.

Note – Whenever the target detects an error or receives a message from the initiator indicating an error has occurred, the target requests that the initiator return to the location specified by the pointers to re-execute the operation. The target makes this request by sending a Restore Pointers message.

Message System

The message system allows SCSI devices to communicate for physical path management. There are two ways to transfer messages during the Information Transfer phase:

Message In	Messages from the target to the initiator
Message Out	Messages from the initiator to the target

The ATN signal prompts the target to start the Message Out phase. The Message Out phase is the next phase entered by the target; however, it can start at any time after detecting an Attention condition.

If the target receives any message other than Identify, Abort, or Bus Device Reset as the *first* message after selection, the target aborts the operation and enters the Bus Free phase. [TABLE 3-4](#) lists the valid messages for the library:

TABLE 3-4 Messages

Hex Code	Description	Direction
00	Command Complete	In
01	Extended	Out
02	Save Data Pointers	In
03	Restore Pointers	In
04	Disconnect	In
05	Initiator Detected Error	Out
06	Abort	Out
07	Message Reject	In/Out
08	No Operation	Out
09	Message Parity Error	Out
0C	Bus Device Reset	Out
80–FF	Identify	In/Out
Note: In = Target to initiator, Out = Initiator to target		

In general, SCSI supports two types of messages:

- Messages containing a single byte
- Messages containing multiple bytes

The following sections describe the valid messages along with their hexadecimal code values.

Message Codes

The following paragraphs explain the messages in [TABLE 3-4 on page 24](#).

Command Complete Message In

The library sends the Command Complete message (00) to the initiator to indicate that the execution of the command has completed and that valid status has been sent to the initiator.

Extended Message

The initiator might try to negotiate wide or synchronous transfers. The library accepts these negotiations but always negotiates to narrow and asynchronous transfers.

Save Data Pointers In

The library sends the Save Data Pointers message (02) to tell an initiator to save a copy of the active data pointer for the library. The library sends this message before sending the Disconnect message.

Restore Pointers Message In

The library sends the Restore Pointers message (03) to direct an initiator to restore the most recently saved command, data, and status pointers for the active I/O process. The message is sent after receiving an Initiator Detected Error message or Parity error during a transfer which can be retried. The transfer is then restarted.

Disconnect Message In

The library sends the Disconnect message (04) to inform an initiator that the present connection is going to be broken and that a later reconnect is required to complete the current command. After successfully sending this message, the library enters the Bus Free phase.

Initiator Detected Error Out

An initiator sends the Initiator Detected Error message (05) to inform the library that the initiator has detected an error. Depending on the active phase, the library aborts the current I/O, sends a Message Reject, or issues a Restore Pointers, and restarts the transfer.

Abort Out

An initiator sends the Abort message (06) to the library to halt a process. If an L_T_L nexus is established, any pending data and status is cleared and the process is aborted; otherwise, no action is taken.

Message Reject In/Out

Either an initiator or the library sends a Message Reject (07) to indicate the last message received was inappropriate or not supported.

No Operation Out

When a library receives a No Operation message (08), command processing continues without any action taken.

Message Parity Error Out

The library receives a Message Parity Error (09) when an initiator detects bad parity on a message byte. If the last phase was Message In, the library resends the message byte again.

Bus Device Reset Out

The Bus Device Reset message (0C) causes the library to immediately go to the Bus Free phase and resets the SCSI interface.

Identify Message In/Out

Either the initiator or the library sends the Identify message (80 to FF). The initiator sends this message to the library to enable the message system.

Identify messages are sent by either the initiator or the target to establish the physical path connection between an initiator and the target for a particular logical unit. The library sends this message to the initiator following the reselection sequence. The format of this message is

Bit	7	6	5-0
Value	Identify	DiscPriv	LUN

Identify This bit is set to 1 to distinguish the Identify message from all other messages.

DiscPriv The disconnect privilege bit is used by the initiator to grant the library disconnect privileges:
 0 = Disconnect is not allowed
 1 = Disconnect is allowed
 When the Identify message is sent by the library, the DiscPriv is set to 0.

LUN The only supported Logical Unit Number (LUN) for the library is 0.

Additional information regarding the messaging system (or messaging) can be found in the SCSI-3 standard.

Message Sequencing and Handling

During the selection phase, the Identify message must be the first message out from the initiator to the library. This message initiates the message system. The library must receive an Identify message during the selection phase to enable it to respond to the attention line during subsequent phases. When the message system has been initiated by the Identify message during the selection phase, the library accepts messages from the initiator when the attention line is active.

Synchronous Negotiations

The library will accept negotiations for synchronous communication but will always negotiate to asynchronous communication.

Wide Negotiations

The library will accept negotiations for wide transfers but will always negotiate to narrow, 8-bit transfers.

Status Byte

The target returns a status byte to the initiator at the completion of each command during the Status phase unless the command is cleared or interrupted by:

- An Abort message
- Device Reset message
- A “hard” reset condition
- An unexpected disconnect

TABLE 3-5 Status Byte

Bytes	Bit							
	7	6	5	4	3	2	1	0
1	Reserved		Status Byte Code					Rsvd

The library supports four status byte codes:

- Good (00)
- Check Condition (02)
- Busy (08)
- Reservation Conflict (18)

Good

Good status (00) indicates that the device successfully completed the command.

Check Condition

Check Condition status (02) occurs when any error, unit exception, or abnormal condition generates sense data. The initiator should issue a Request Sense command following a Check Condition status to determine the nature of the error.

Check Condition status occurs when one of the following conditions exist:

- Issuing an invalid command or parameter
- Issuing a command to a device that is not ready
- Detecting a hardware error
- Sensing an illegal request
- Detecting SCSI protocol errors

Busy

Busy status (08) occurs when the target is unable to accept a command from an otherwise acceptable initiator. The normal initiator recovery from a Busy status is to reissue the command.

Reservation Conflict

The library returns Reservation Conflict status (18) whenever a SCSI initiator attempts to access a logical unit or element that is reserved by another initiator.

Multiple Initiator Support

The library architecture supports multiple initiators with the following details:

- Up to 16 SCSI devices are supported. The library can be on a bus with a maximum of two initiators. In this configuration, the tape drive SCSI interfaces would be required to be on a separate SCSI bus.
- Unit - Reserve and Release commands are supported. Persistent Reserve commands also are supported. An initiator may reserve elements that will then cause a reservation conflict if the reserved element is accessed by a different initiator. Host software applications should perform reservations whenever possible.
- If an initiator modifies a mode page, all other initiators will then receive a unit attention indicating the mode parameters have changed.
- The library maintains separate prevent/allow medium removal status for each initiator. If any host/initiator has issued a prevent command, then no access to the Cartridge Access Port (CAP) door will be allowed.
- If any initiator sends an Allow Media Command (Prevent bit set to 0), the library clears the prevent bit for all hosts and allows the operator to open the CAP.

Host TimeOut Characteristics

Host timeout values for the SCSI bus may require adjustment based on the configuration of the library. The maximum timeout value is 10 minutes (for the maximum library configuration.)

Fast Load

The library architecture provides for optional fast load operations. The following applies only if the fast load option is disabled. (If the fast load option is disabled, then the library's robot will mount a tape to a drive and wait at the drive location until the tape is fully loaded before beginning another task.)

If the fast load option is disabled, a SCSI move command may require additional time to complete. The library remains disconnected during this time. The host software must adjust SCSI time-out values to allow for the tape drive load time in addition to the robotics motion time.

Device Reservations

The library supports the Reserve/Release management method and the Persistent Reservations management method. These methods are defined in the *ANSI SCSI-3 Primary Commands (SPC-3)* standard. For the reservation restrictions placed on:

- The Reserve/Release management method, see [TABLE 3-6](#).
- The Persistent Reservations management method, see [TABLE 3-7](#).

Conflict	Command will not be performed and the library will terminate the command with Reservation Conflict status.
Allowed	Command will be allowed to execute to normal completion.

TABLE 3-6 Reserve/Release Management Method

Command	Action when Reserved by a different Initiator
Initialize Element (07h)	Conflict
Initialize Element with Range (37h)	Conflict
Inquiry (12h)	Allowed
Log Sense (4Dh)	Allowed
Mode Select (15h/55h)	Conflict
Mode Sense (1Ah/5Ah)	Conflict
Move Medium (A5h)	Conflict
Persistent Reserve In (5Eh)	Conflict
Persistent Reserve Out (5Fh)	Conflict
Position to Element (2Bh)	Conflict
Prevent/Allow Removal (1Eh)	Prevent = 0, allowed Prevent = 1, conflict
Read Element Status (B8h)	Conflict
Release Unit (17h/57h)	Allowed, the reservation is not released.
Report LUNS (A0h)	Allowed
Request Sense (03h)	Allowed
Request Volume Element Address (B5)	Conflict
Reserve Unit (16h/56h)	Conflict
Send Diagnostic (1Dh)	Conflict
Send Volume Tag (B6h)	Conflict
Test Unit Ready (00h)	Conflict
Write Buffer (3Bh)	Conflict

TABLE 3-7 Persistent Reservation Management Method

Command	Non-registered Initiators	Registered Initiators
Initialize Element (07h)	Conflict	Allowed
Initialize Element with Range (37h)	Conflict	Allowed
Inquiry (12h)	Allowed	Allowed
Log Sense (4Dh)	Allowed	Allowed
Mode Select (15h/55h)	Conflict	Allowed
Mode Sense (1Ah/5Ah)	Conflict	Allowed
Move Medium (A5h)	Conflict	Allowed
Persistent Reserve In (5Eh)	Allowed	Allowed
Persistent Reserve Out (5Fh)	Register, allowed Reserve, conflict Release, conflict Clear, conflict Preempt, conflict Pre/Abt, conflict Reg/Ign, allowed	Register, allowed Reserve, conflict Release, allowed Clear, allowed Preempt, allowed Pre/Abt, allowed Reg/Ign, allowed
Position to Element (2Bh)	Conflict	Allowed
Prevent/Allow Media Removal (1Eh)	Prevent = 0, allowed Prevent = 1, conflict	Allowed
Read Element Status (B8h)	Conflict	Allowed
Release Unit (17h/57h)	Conflict	Conflict
Report LUNs (A0h)	Allowed	Allowed
Request Sense (03h)	Allowed	Allowed
Request Volume Element Address (B5h)	Conflict	Allowed
Reserve Unit (16h/56h)	Conflict	Conflict
Send Diagnostic (1Dh)	Conflict	Allowed
Send Volume Tag (B6h)	Conflict	Allowed
Test Unit Ready (00h)	Conflict	Allowed
Write Buffer (3Bh)	Conflict	Allowed

Fibre Channel Physical Interface

This chapter describes how the Sun StorageTek SL500 tape library attach to Fibre Channel (FC), and it includes recommendations for hubs, cables, and connectors.

Ports

Library ports are N*_Ports in a Fibre Channel topology.

The “N*” here stands generically for a type of “node” port.

More specifically, the link at the library can be a N_Port in a point-to-point topology but is more often an NL_Port in an arbitrated loop topology.

An N*_Port supports:

- one media type,
- one media rate, and
- one or more classes of service.

Note: Currently, Class 3 Service is the only class of service that the libraries support.

Thus data transmission between N*_Ports occurs only if the ports have the same media type, the same media rate, and at least one class of service in common. In addition, in arbitrated loop topologies, one N*_Port typically communicates with only one other N*_Port on the loop at a time. For more information about arbitrated loop topologies, see [“Arbitrated Loop” on page 34](#).

When an N*_Port is connected to a Fibre Channel fabric, typically through an F*_Port, the breadth of possibilities for data transmission increases because the fabric topology permits:

Many pairs of N*_Ports to communicate at the same time

Communication between dissimilar N*_Ports

For more information about the Fibre Channel fabric topology, see [“Direct Fabric Attachment” on page 38](#).

Topologies

StorageTek libraries support the following topologies with single port attachment:

- Arbitrated Loop—private loop
- Arbitrated Loop—public loop
- Direct fabric attachment

Arbitrated Loop

In a Fibre Channel arbitrated loop, as with the SCSI protocol, when devices want to communicate on the bus, they must arbitrate and win the connection before communications can begin. Once a device is powered on and initialized on the loop, it must arbitrate and win to be able to communicate with other devices on the loop.

Private Arbitrated Loop

If the arbitrated loop is not attached to a Fibre Channel fabric (that is, to an F*_port), it is a private loop. A private arbitrated loop can connect up to 126 NL_ports. Again only point-to-point communication is possible between one initiator and one target at any time. (Other links on the loop act as repeaters.) In addition, initiator and target must reside within the same loop. Its best implementation includes a Fibre Channel hub (see [“Arbitrated Loop with Hub” on page 35](#)).

Public Arbitrated Loop

If the arbitrated loop contains at least one FL_port—that is, is attached to a Fibre Channel fabric—it is a public loop. A public loop can contain up to 126 NL_ports and one FL_port. If the fabric connects to another arbitrated loop, then an initiator on one public loop might be able to communicate with a target on another. For more about Fibre Channel fabric, see [“Direct Fabric Attachment” on page 38](#).

Arbitrated Loop with Hub

Arbitrated loops become more viable when they include a hub, a device containing bypass circuitry for configurations of 8 to 16 ports. See [FIGURE 4-1](#).

FIGURE 4-1 Arbitrated Loop with Hub

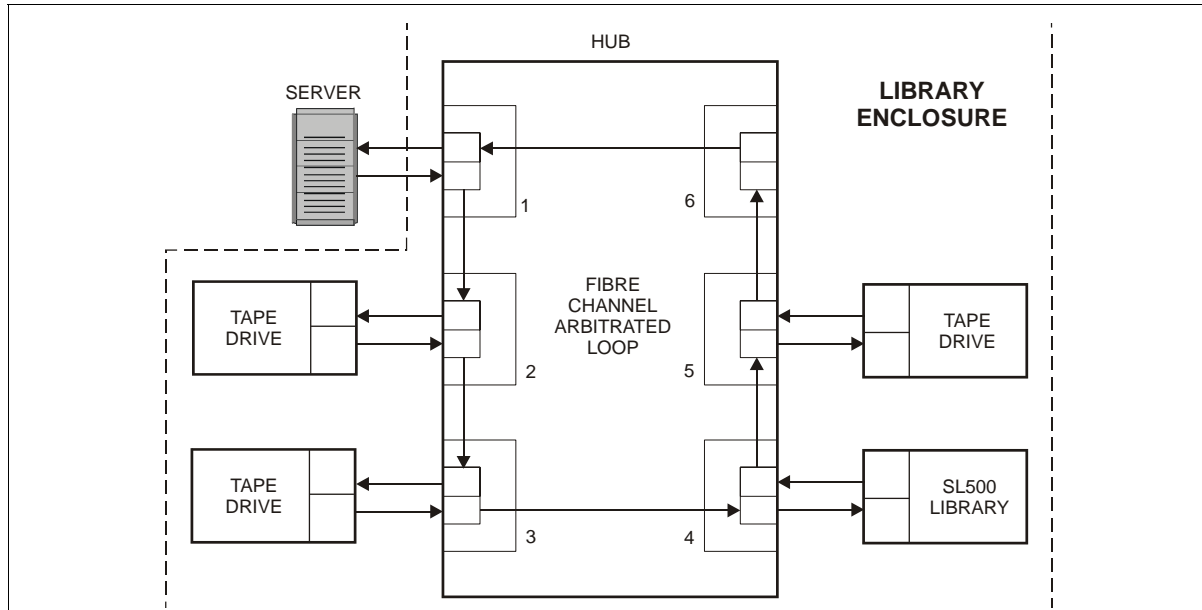

Hubs

Sun StorageTek libraries are designed to work with hubs that create an arbitrated loop with the following capabilities:

- Provides port bypass functionality for port failures
- Centralizes the attachment—within the arbitrated loop—of the tape drives in the library
- Establishes connections with either copper or fiber optic cables
- Provides translation of physical media (such as copper to optical fiber)
- Provides an external power supply for the port bypass
- Allows cascading to increase tape drive/library and initiator attachment
- Supports the ability to power on and off, install or deinstall tape drives or libraries
- Provides a central point of port management and monitoring of the tape drives and libraries
- Extends the distances between tape drives/libraries and initiators

The 19 inch rack space within the libraries supports the installation of Fibre Channel hubs or switches. This allows most of the fiber cabling to reside inside the library enclosure.

Because of the fast growth and the increase in demand of Fibre Channel attachments, hubs can provide cascading (multiple) loops within a fibre channel network (see [“Cascading Hubs” on page 37](#)).

Considerations for Hubs

Jitter is a consideration when selecting, installing, and configuring hubs within a Fibre Channel network. Jitter is the deviation of timing of an exchange.

The accumulation of jitter occurs and continues to grow within a chain of repeaters. As a signal is input to a repeater, jitter is not removed from the clock and is transferred to the data at the output. At some level within the network, jitter could exceed the allowable limit causing excessive errors. Assuring that there are N_Ports within the loop to reclock the signal, jitter will be minimized.

Loop Port State Machines (LPSM) are required to control the operation of the loop and ensure Loop Initialization Protocol (LIP) is executed whenever a reset or power-on occurs.

Cascading Hubs

There is no limit to cascading the number of hubs within a network as long as the following guidelines are followed:

Note – Refer to the hub manufacturer’s requirements for cascading, the following are just general guidelines.

- Note that the length of the cable affects the number of allowable ports.
- Note that the hub adds length to the cabling in the network. (See “[Cable Guidelines for Hubs](#)” on page 40.)
- Use ports 1 and 4 to cascade to other hubs. This increases the potential of dual port devices and redundant paths.
- Do not exceed the maximum number of hubs per cascade link. The maximum number of hubs before retiming is six (6) with short cables, two (2) with maximum length cascade cables.
- Configure the loop so the devices are properly positioned in relation to the hub.

FIGURE 4-2 is an example of cascading hubs.

FIGURE 4-2 Cascading Hubs

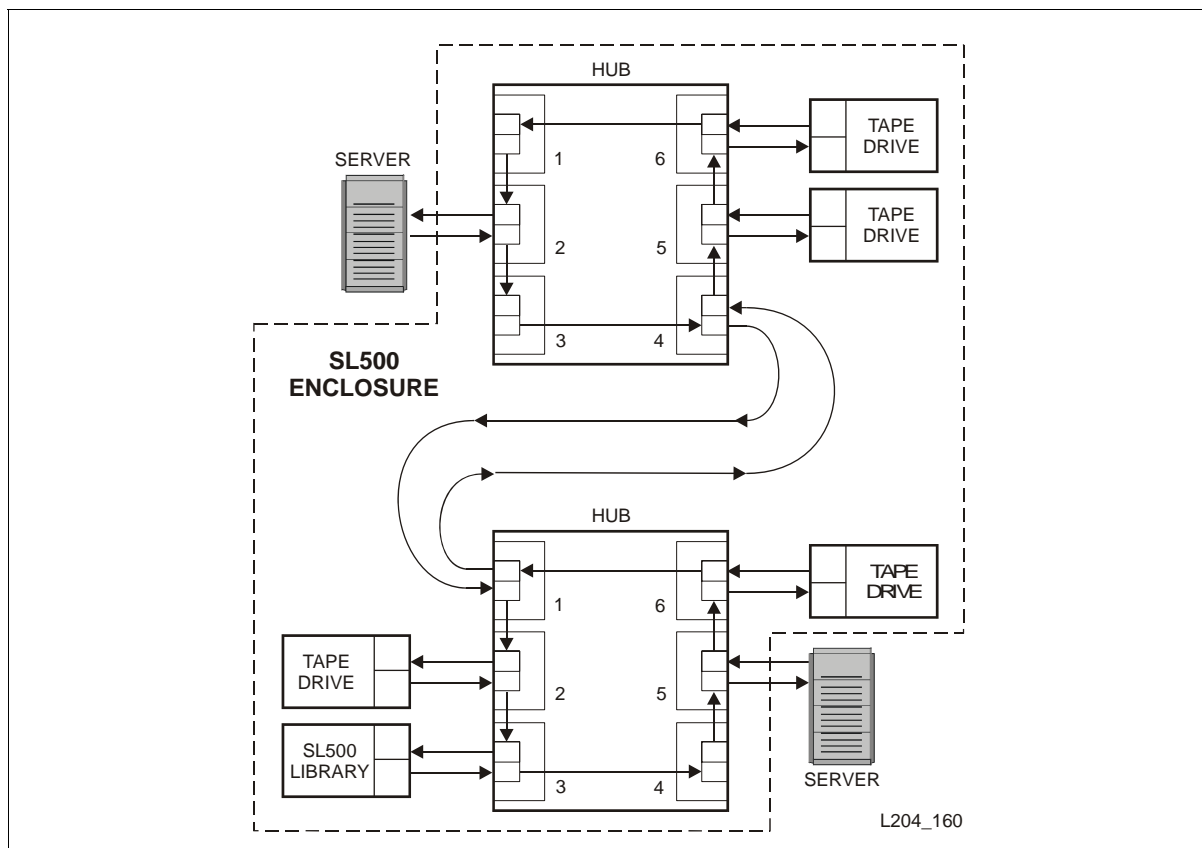

Loop with a Switch and a Hub

A public arbitrated loop can include a hub that is attached to a fabric element, in this case a switch (see [FIGURE 4-3](#)).

FIGURE 4-3 A Loop with a Hub Attached to a Switch

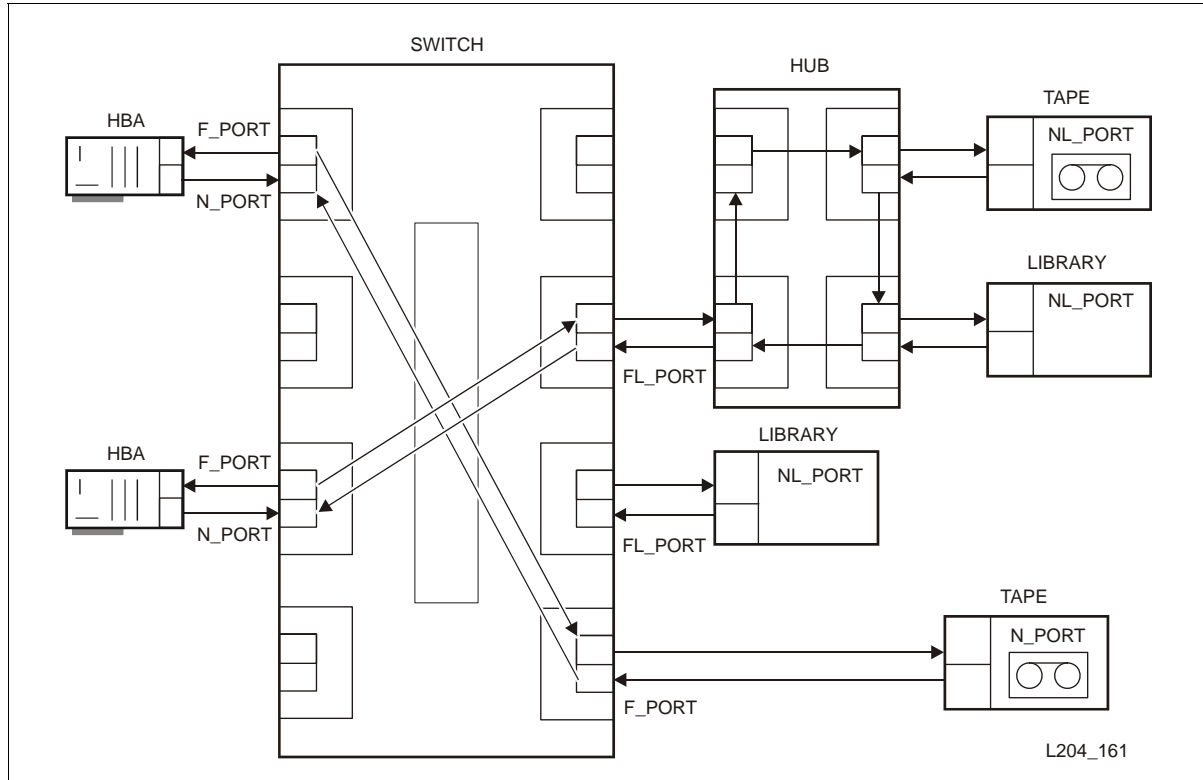

Direct Fabric Attachment

The advantage of attaching a library to a fabric is that the fabric can aid the library's communication with a variety of devices. A fabric element might:

- Attach N*_Ports with different media types, media rates, or classes of service
- Attach arbitrated loops
- Serve as a root element for distributed fabric elements

A fabric element might support different:

- Port types
- Classes of service
- Media types
- Media rates
- Address assignment methods
- Frame routing techniques

After a frame leaves the source N*_Port and enters the fabric, each fabric element selects the next link toward the destination N*_Port. Usually the path includes two links between the source N*_Port and the destination N*_Port.

Cables and Connectors

Because the link to a port can be driven either optically or electrically, the term “fibre” in Fibre Channel refers to either a fiber optic or a copper cable.

- Optical transmission occurs over both single and multi-mode fibers using both laser and light emitting diodes (LEDs) for both short (770–850 nm) and long (1300–1360 nm) wavelengths.
- Electrical transmissions occur over video coax, miniature coax, twin coax (Twin Ax), or twisted pair.

TABLE 4-1 lists the cable and connector specifications that the libraries support.

TABLE 4-1 StorageTek Library Cables and Connectors

Distance		FC-0 Code (see note)	Cable	Type	Connector
Meters	Feet				
2-150	6.5-490	200-M6-SN-1	62.5 μ m Multimode	780 nm Shortwave laser w/o OFC	Keyed Duplex LC
2-300	6.5-985	100-M6-SN-I	62.5 μ m Multimode	Shortwave laser w/o OFC	Keyed Duplex SC
2-500	6.5-1640	100-M5-SN-I	50 μ m Multimode	Shortwave laser w/o OFC	Keyed Duplex SC

Notes:
See FIGURE 4-4 for a description of the FC-0 code information.
See TABLE 4-2 for specific part numbers.

FIGURE 4-4 FC-0 Level Communication About Media (Cables)

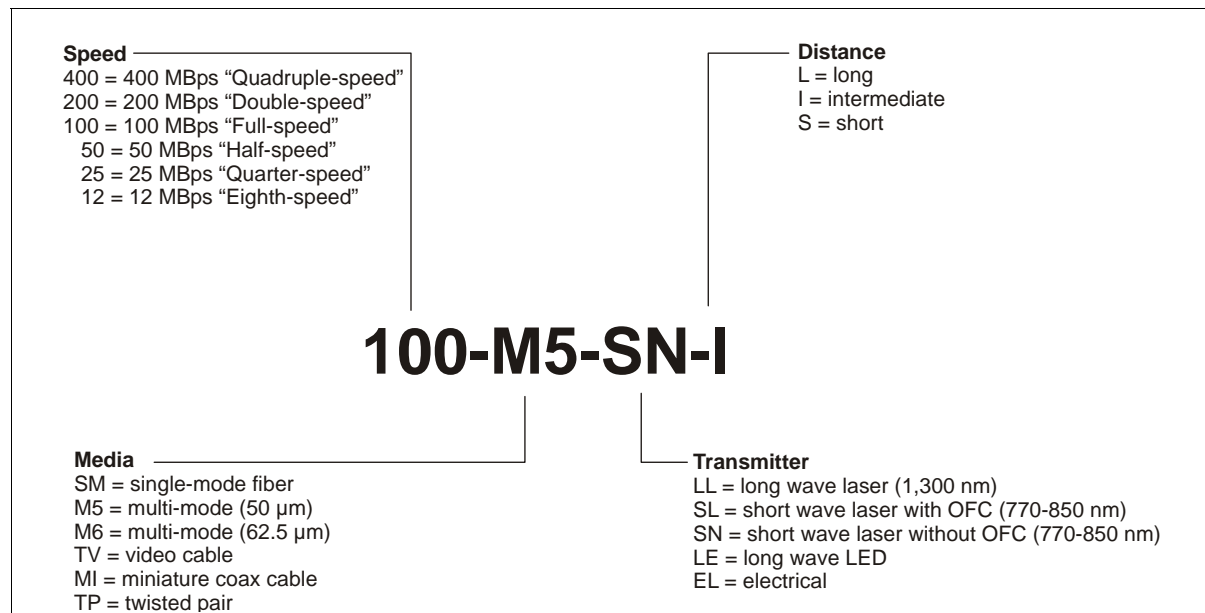

Cable Part Numbers

Part numbers and descriptions for StorageTek Fibre Channel cables are listed in the table below. According to [FIGURE 4-4](#), these cables would prompt the following FC-0 media information: 100-M5-SN-I.

TABLE 4-2 Fiber-Optic Cables: 50 μ m Multimode, SC-to-SC Connectors

Description—Plenum rated	Part Number
5 m (16.4 ft)	10800123
20 m (65.6 ft)	10800125
50 m (164 ft)	10800127
100 m (328.1 ft)	10800128
250 m (820.2 ft)	10800129
500 m (1640.4 ft)	10800130
Note: Plenum-rated cables can withstand higher temperatures and can be used for both under-floor and riser applications.	

Cable Guidelines for Hubs

Guidelines for cable lengths to a hub (per cascade) include:

- Minimum cable length is 2 m (6.5 ft)
- Maximum cable length depends on the type of connection:
 - Copper = 10 m (32.8 ft) intra cabinet
 - Copper = 30 m (98.4 ft) inter cabinet
 - Short-wave fiber optics = 500 m (1,640 ft)
 - Long-wave fiber optics = 10 kilometers (6.2 miles)

Giga-bit Interface Converters

Sun StorageTek hubs use Giga-bit Interface Converters (GBIC) to provide the physical connection to the libraries and drives.

GBICs are available with high speed serial data connectors (HSSDC), 9-pin shielded "D" connectors (DB9), shortwave non-OFC, and longwave laser connections.

Fibre Channel Operations

This chapter describes how the SL500 library operates using Fibre Channel.

Fibre Channel Levels

TABLE 5-1 shows the five levels and arbitrated loop (FC-AL) grouping of functions for transmission over a Fibre Channel interface.

TABLE 5-1 Fibre Channel Levels

Levels	Function	Content
FC-4	Upper Level Protocol Mapping	<ul style="list-style-type: none"> ■ Mapping of ULP functions
FC-3	Common Services	
FC-2	Link Service	<ul style="list-style-type: none"> ■ Login and Logout services ■ Basic Link and Extended Link services
	Signaling Protocol	<ul style="list-style-type: none"> ■ Frames, sequences, and exchanges ■ N_Ports, F_Ports, and topologies ■ Classes of Service (1, 2, and 3) ■ Buffer-to-buffer/end-to-end flow control
FC-AL	Arbitrated Loop Functions	<ul style="list-style-type: none"> ■ Ordered sets for loop arbitration ■ Loop initialization ■ Physical address assignments
FC-1	Transmission Protocol	<ul style="list-style-type: none"> ■ Encoding and decoding ■ Link management ■ Error monitoring
FC-0	Physical Interface	<ul style="list-style-type: none"> ■ Transmitters, receivers, and bandwidth
	Media	<ul style="list-style-type: none"> ■ Cables and connectors

The remaining sections of this chapter explain how these levels work.

Terms/Definitions

Tables throughout this chapter use the following terms to show compliance with ANSI's Fibre Channel Tape (FC-Tape) Technical Report and to show how Sun StorageTek implements them.

FC-Tape Terms

Allowed (A): Can be used between an initiator and a target (library or tape drive). This status is typically dependent on the particular feature or parameter and its applicability to the request from an initiator.

Invokable (I): Can be used between an initiator and a target. For example, if a feature is invoked, the recipient must implement and respond to the feature or parameter.

Prohibited (P): Can *not* be used between an initiator and a target.

Required (R): *Must* be used between an initiator and a target. Both the initiator and target must implement the feature or parameter.

Dash (-): This parameter is not meaningful.

Blank (): The feature is not part of the feature set.

Initiator: SCSI device that originates commands.

Target: SCSI device that receives commands.

Sun StorageTek Terms

Yes (Y): Sun StorageTek library conforms to that command, feature, or value.

No (N): Sun StorageTek library does *not* conform to that command, feature, or value.

Originate (Orig.): Originates the exchange or SCSI command from the library.

Response (Resp.): Returns an acknowledgement (R_RDY and/or data) from the library.

Transmission Word: A four-byte character containing 32 bits of information. This is the smallest information unit transmitted on Fibre Channel. See [TABLE 5-2](#).

TABLE 5-2 Transmission Word

Word	Byte 0	Byte 1	Byte 2	Byte 3
	(MSB) Bits (LSB)			
n	31	24 23	16 15	8 7 0
	(MSB) = Most significant bit		(LSB) = Least significant bit	

Error Detection and Management

In the Fibre Channel protocol, error detection falls into two categories: frame errors and link-level errors.

- Frame errors result in missing or corrupted frames, which may ultimately involve the Fibre Channel protocol level to resolve.
- Link-level errors include errors such as loss of signal, loss of synchronization, and timeouts.

Some protocols provide for error detection and management by using timeouts, which is an inefficient mechanism to detect and recover from frame transmission errors.

A problem with Class 3 operation (currently the only FC-2 Service Class supported) is that it offers no confirmation of frame delivery. However, the originator can deduce some delivery of frames from successfully receiving a command when:

- FCP Transfer Ready was sent by the command recipient
- A response was received

Fibre Channel provides no error correction on data during transfers, but it does provide excellent error detection schemes, including:

- 8B/10B encoding and decoding (see [“8B/10B Encoding and Decoding” on page 45](#))
- Disparity (see [“Disparity” on page 45](#))
- Sequence errors and out-of-order delivery (see [“Sequence Errors” on page 64](#))
- Cyclic redundancy checks (CRC) (see [“CRC” on page 64](#))

FC-0 Features

The FC-0 level defines the physical level of the Fibre Channel protocol. This includes media types, connectors, and the optical characteristics that are necessary for connecting ports.

FC-0 and Initialization

A minimum level of initialization occurs at the FC-0 level.

When the library is powered on, this level assures that the links are active and initializes any shortwave laser transmitters. Longwave laser transmitters and all receivers are ready immediately. The level conveys any loss of signal state to the FC-1 level, which reports it to the FC-2 level.

Device States (FC-0, FC-1, FC-2)

The following sections describe the relationships between library states and port states and between library states and incoming commands. Communication about device states involves the FC-0, FC-1 and FC-2 levels.

Power Up

When the library completes the power-on process, both of the Fibre Channel ports are enabled and attempt to initialize on the attached Fibre Channel topology.

When the library completes the power-on initialization process, the library (LUN=0) transitions from offline to online and is capable of media changer operations.

Not Ready

Commands like Inquiry that do not require the library to be online will still execute normally.

All other commands that require the library to be online will get a Check Condition status.

Ready

All available commands may now be executed with the library.

Power Down

In the process of powering down the library, the Fibre Channel Protocol chips will lose power. If the library is connected to a hub or switch, the hub/switch bypass will be activated. The library has no port bypass capability.

FC-1 Features

The FC-1 level of the Fibre Channel protocol defines the transmission protocol. This level includes the 8B/10B encoding/decoding scheme, word order transmission, and error detection.

FC-1 and Initialization

During initialization, the FC-1 level provides an encoded bit stream (primitive sequence) to the FC-0 level. When the FC-1 level, in turn, receives a proper bit stream, the FC-1 level converts the stream into a form used by the FC-2 level. The process achieves synchronization for both transmission characters and transmission words.

8B/10B Encoding and Decoding

Fibre Channel uses a special process called encoding and decoding that is designed to reduce distortion during transmission and aid in the detection of errors at the receiving port. This process makes it highly likely that single and multiple bit errors are detected.

Besides providing error detection, this process also balances the turning on and off of the light for the loading of the optical fiber transmitters.

The process of encoding uses an algorithm that takes the original 8 bits in each byte and transforms them into 10 bits for transmission. The result is an 8B/10B encoding of a byte which is referred to as a transmission character.

Disparity

Along with the 8B/10B encoding, Fibre Channel uses another scheme to protect transmission characters and aid in error detection: running disparity. Running disparity adds a second dimension to the transmission of characters. This dimension provides a balance of ones and zeros, which helps protect transmission characters and controls the heat output of the transmitter.

A negative running disparity is maintained following the transmission of the end-of-frame (EOF) delimiter. It remains negative until the transmission of the next start-of-frame delimiter.

Because the running disparity within a frame is variable, two different EOF delimiters are used (see [TABLE 5-3](#)), depending on the content of the frame following the transmission of the CRC (see [“CRC” on page 64](#)).

TABLE 5-3 End of Frame Delimiters

Delimiter	Abbreviation	RD	Transmission Word Characters			
EOF Normal	EOFn	Neg.	K28.5	D21.4	D21.6	D21.6
		Pos.	K28.5	D21.5	D21.6	D21.6
EOF Terminate	EOFt	Neg.	K28.5	D21.4	D21.3	D12.3
		Pos.	K28.5	D21.5	D21.3	D21.3
EOF Abort	EOFa	Neg.	K28.5	D21.4	D21.7	D21.7
		Pos.	K28.5	D21.5	D21.7	D21.7
EOF Normal Invalid	EOFni	Neg.	K28.5	D10.4	D21.6	D21.6
		Pos.	K28.5	D10.5	D21.6	D21.6

FC-AL Features

Initialization and other processes take on special attributes and functions in an arbitrated loop topology. The following sections explain these attributes and functions as specified in the Fibre Channel Arbitrated Loop (FC-AL) specification.

Initialization

Arbitrated loop initialization protocol assigns up to a possible 126 addresses to different ports on the loop and builds a map of these addresses. The following sections describe some loop initialization features that StorageTek libraries perform.

Loop initialization must occur before operations on the loop can begin. The Loop Initialization Primitive (LIP) sequence is a series of initialization frames that establish NL_Ports on the loop.

Any NL_Port on the loop is capable of starting an initialization sequence by transmitting LIP. When the next NL_Port detects the LIP sequence, it retransmits it to the next NL_Port until the LIP sequence travels around the loop to the NL_Port initiating the sequence. During loop initialization, NL_Port addresses (AL_PA) are assigned (00h to EFh).

NL_Port addresses (AL_PA) can be either hard (hardware assigned) or soft (system assigned) during loop initialization.

An NL_Port attempts to establish its previous acquired address before attempting to acquire another address. This occurs when the NL_Port is powered on, experiences a power-on reset, recognizes a LIP (AL_PD or AL_PS), or experiences any other event that causes the NL_Port to lose communications.

Note – Sun StorageTek libraries may use a hard-assigned address (entered through the Library Console or with the Horizon Library Monitor) and attempt to assign that address during loop initialization. If unable to obtain that address, the libraries accept soft addresses by the system.

Address Processes

Initialization involves address acquisition as described in the following sections.

Arbitrated Loop Physical Address

When an NL_Port enters the loop (such as a power-on), it begins initialization to acquire an address and to notify other ports there is a change in configuration.

Note – If there is an exchange in process when a LIP begins, that exchange is disrupted and possible frame corruption could occur, which would result in an Upper Level Protocol timeout.

- If the NL_Port does not have a valid address, it begins the initialization sequence with LIP(F7,F7).
- If the NL_Port has a valid address, it begins initialization with LIP (F7,AL_PS).

Loop Initialization Fabric Assigned Address

StorageTek libraries support the process of Loop Initialization Fabric Assigned (LIFA) addresses. This process is supported when the library is operating in Public Loop mode.

Loop Initialization Previously Acquired

StorageTek libraries support the process of Loop Initialization Previously Acquired (LIPA) addresses. This process is supported when the library has previously acquired an address.

Loop Initialization Hard Assigned

StorageTek libraries support the process of Loop Initialization Hard Assigned (LIHA) addresses. This process is supported when the library is first powered-on and a configuration parameter enables it.

Loop Initialization Soft Assigned

StorageTek libraries support the process of Loop Initialization Soft Assigned (LISA) addresses. This process is supported when the hard-assigned address has been used by a different device or the hard-assigned addressing is disabled.

Failure to Obtain a Loop Address

If an NL_Port is unable to obtain an address (fabric assigned, previously assigned, hard assigned, or soft assigned), it goes into a non-participating mode and immediately implicitly logs out all NL_Ports.

If an NL_Port experiences a power-on reset or recognizes a LIP(AL_PD,AL_PS), it is not required to retain a previously acquired address to use during the next loop initialization.

Open State/Loop Initialization

The open initializing (OPEN-INIT) state performs the process of loop initialization. When ports are in this state, initialization frames are transmitted and received to identify the temporary loop master and to assign AL_PA values. Entering this state assumes the loop is operational and sets the Available BB_Credit equal to zero. (See [“Login_BB_Credit Equals Zero” on page 51.](#))

Related Processes

The following processes might occur during initialization.

Loop Initialization Select Master

StorageTek libraries support the process of selecting a Loop Initialization Select Master (LISM) by using the device with the lowest port address.

Note – If an FL_Port (fabric loop attachment) is present, it assumes the role of Loop Initialization Select Master.

Loop Initialization Report Position

StorageTek libraries support the mapping process to build a map of the AL_PA values according to the library’s position on the loop. The temporary loop master begins the procedure to create a Loop Initialization Report (LIRP).

This initialization report and map is done by using a 1-word frame identifier with an offset value of one (1). As the frame is transmitted around the loop, the next NL_Port increments the offset by a value of one and stores the information in the AL_PA map.

Selective Reset

Selective resets perform a reset on the receiving port. These resets are helpful for error recovery or reconfiguration of the loop. Any NL_Port that uses a selective reset transmits a LIP(AL_PD,AL_PS). Refer to [TABLE 5-28](#) for clearing effects.

- AL_PD field contains the address of the port being reset
- AL_PS contains the address of the port issuing the reset

Loop Failures

A loop failure is any of the following:

- A loss of signal
- A loss of synchronization for longer than R_T_TOV (For more information on R_T_TOV, see [“Timers” on page 65.](#))

If a Loop Failure occurs, the L_Port that detects the failure issues a LIP(F8,AL_PS) if it has a valid AL_PA, or LIP(F8,F7) if it doesn't.

Loop Initialization Loop Position

StorageTek libraries support the process of Loop Initialization Loop Position (LILP) by retransmitting this sequence when required.

Completion Processes

The following processes occur after loop initialization.

Private Loop Initialization Completion

At this point in loop initialization, a private loop library has completed initialization. It has acquired a private loop address of 00 00 xx. The xx is its assigned AL_PA.

The library now waits for initiators, on this loop only, to complete a Port Login (PLOGI), to complete a Process Login (PRLI), and then to start executing commands.

Public Loop Initialization Completion

The public loop library has at this point acquired a loop address of 00 00 xx at this point in initialization, where xx is its assigned AL_PA.

Next, the library will attempt a Fabric Login (FLOGI) with the loop FL_Port. If the login is not successful, the library will revert back to private loop operation (see [“Private Loop Initialization Completion” on page 49.](#))

With the successful completion of the FLOGI, the library has now acquired its public loop address: DD AA xx. DD is the fabric domain; AA is the fabric area; and xx is the AL_PA.

The library then attempts to Port Login (PLOGI) with the fabric directory server to register with an RFC-4 request with the name service.

The library now waits for initiators, on either this loop or fabric attached, to complete a Port Login (PLOGI), to complete a Process Login (PRLI), and then to start executing tape commands.

Feature Set

Sun StorageTek libraries implement the following FC-AL feature set:

TABLE 5-4 FC-AL Feature Set

Feature	FC-Tape		StorageTek	Notes
	Initiator	Target		
Attempt to acquire Hard Address during LIHA sequence of loop initialization following loss of power, power-on reset, or recognition of LIP (AL_PD or AL_PS)	R	R	Y	4
LILP/LIRP: Loop Master can originate	R	R	Y	
Non-loop Master L_Ports accept	R	R	Y	
Login_BB_Credit: Advertise Login_BB_Credit = 0	A	A	Y	
Advertise Login_BB_Credit > 0	A	A	N	
Accept Login_BB_Credit = 0	R	R	Y	
Accept Login_BB_Credit > 0	R	R	Y	1
LPEyx/LPByx/LPEfx (origination)	A	P	N	2
MRKtx (origination)	P	P	N	3
Open Full Duplex - OPN(yx): Open Originator can send	I	I	N	
Open Recipient accepts	R	R	Y	5
Open Half Duplex - OPN(yy): Open Originator can send	I	I	Y	
Open Recipient accepts	R	R	Y	
Open Multicast/Selective Replicate OPN(yr), OPN(fr): Open Originator	P	P	N	
Notes:				
1. The actual value is between 0 and the LOGIN_BB_Credit.				
2. LPEfx is useful for resetting bypass circuits of NL_Ports that have lost their address.				
3. Any NL_Port receiving an MRK attempts to forward it, StorageTek does not originate it.				
4. This feature is user-configured. The default setting is "Disabled."				
5. Our target will accept the Open Full Duplex, but the FCP simplex protocol does not take advantage of the full duplex capabilities.				

Login_BB_Credit Equals Zero

StorageTek libraries advertise Login_BB_Credit =0. When Login_BB_Credit=0 at the other L_Port, the following rules apply:

- The OPN originator must receive R_RDYs (receiver readys) from the library before transmitting a frame.
- The OPNed responder transmits R_RDYs for the number of buffers available to receive frames.

Note – Sun StorageTek libraries respond with two to four R_RDYs on an OPN. OPN Originators open as either *full* or *half* duplex, regardless of the value of the Login_BB_Credit.

Open and Close Latencies

When Login_BB_Credit=0, a latency exists while before the libraries respond with two (2) R_RDYs. This exists for every OPN before frame transmission can begin.

Some NL_Ports reduce CLS latency in another way:

To prevent buffer overruns, a CLS recipient is only required to have maximum Login_BB_Credit, granted to any L_Port buffers, available before receiving the next OPN.

Fabric F_PORT Attachment Initialization

In the absence of a loop environment the StorageTek tape libraries will attempt to initialize with a fabric. This is accomplished by doing a Fabric Login (FLOGI). The FLOGI process will be attempted in each class of service that the library supports.

Once the FLOGI process is successful the library will attempt to login (PLOGI) with the fabric attached name server, if it exists. This process allows the device to register its presence with the name server such that other initiators may query the name server to find target tape libraries to use.

The library now waits for initiators on the fabric to complete a Port Login (PLOGI), a Process Login (PRLI), and then to start executing commands.

FC-2 Features

The FC-2 level provides the signaling protocol and specifies the rules and requirements to transfer blocks of data.

The FC-2 level is the most complex level in Fibre Channel protocol and provides the different classes of service, packetizing, sequencing, error detection, and reassembling the transmitted data.

Login Validation

After initialization is complete, a StorageTek library communicates its ID for login validation. This ID is an IEEE-registered 64-byte identifier. The device identification page (36 bytes) of the Inquiry command indicates the vendor-specific portion of this ID. The vendor-specific portion of the ID includes the library's Port name, Node name, and N_Port ID. This information is unique for each Fibre Channel card in each library.

The remaining 28 bytes of the library's ID consist of:

- 5h (a Name Address Authority)
- 00104Fh (Sun StorageTek company ID)

Note – The following table shows the IEEE-registered format for the full 64-byte identification scheme. The format includes the Name Address Authority (NAA), company ID, and vendor-specific identifier.

TABLE 5-5 Library Identification Scheme

Most Significant Byte			Least Significant Byte		
63	60	59	36	35	00
NAA		IEEE Company ID		Vendor Specific Identifier	
5h		00 10 4Fh		(assigned per FC board)	

You can view this ID through the "Lib Fibre I/F Config Menu." See the library's operator's guide for instructions on accessing this menu.

Every device on the loop must have a unique ID for login validation.

All ports validate the logins by comparing Port Name, Node Name, and N_Port ID. All three identifiers must match or this indicates the configuration has changed and requires a Logout (LOGO).

A LOGO terminates all open exchanges between SCSI initiator and target.

Class of Service Parameters

Fibre Channel provides several different strategies to ensure reliable communications between devices. These strategies are called Classes of Service.

The libraries support the Class 3 level of service which provides no notification of frame delivery or non-delivery. This class of service reduces the number of frames (traffic) on the loop.

The start-of-frame (SOF) delimiter specifies the type of service used for each frame during communications.

[TABLE 5-6](#) indicates the two types of delimiters for Class 3 operations.

TABLE 5-6 Start of Frame Delimiters, Class 3

Delimiter	Abbreviation	Transmission Word Characters			
SOF Initiate Class 3	SOFi3	K28.5	D21.5	D22.2	D22.2
SOF Normal Class 3	SOFn3	K28.5	D21.5	D22.1	D22.1

Note: Intermixing different classes of service is not supported.

The libraries adhere to a set of operating characteristics that ensure inter-operability and reliability within a Class 3 loop environment are maintained.

- [TABLE 5-7 on page 54](#) lists the [Class 3 Service Parameters, Port Login \(PLOGI\)](#)
- [TABLE 5-8 on page 55](#) lists the [Class 3 Service Parameters, Fabric Login \(FLOGI\)](#)

Class 3 Service Parameters, Port Login

TABLE 5-7 Class 3 Service Parameters, Port Login

Parameters	Word	Bits	Value	FC-Tape
Class validity	0	31	1	1
Service Options:	0	30–16		
Intermix Mode	0	30	0	–
Stacked Connect Requests	0	29–28	00	–
Sequential Delivery	0	27	0	–
Dedicated Simplex	0	26	0	–
Camp-On	0	25	0	–
Buffered Class 1	0	24	0	–
Priority	0	23	0	–
Initiator Control:	0	15–0	–	–
Sequence Initiator X_ID reassignment	0	15–14	00	–
Initial Responder Process_Associator	0	13–12	00	00
Sequence Initiator ACK_0 capable	0	11	0	–
Sequence Initiator ACK_N Capable	0	10	0	–
ACK generation assistance	0	9	0	–
Initiator Data compression capable	0	8	0	0
Initiator Data compression history buffer size = 00b	0	7–6	00	–
Data Encryption Capable	0	5	0	0
Clock Synchronization Capable	0	4	0	P
Recipient Control:	1	31–16	–	–
ACK_0 Capable	1	31	0	–
ACK_N Capable	1	30	0	–
X_ID Interlock	1	29	0	–
Error Policy Supported	1	28–27	0	01
Categories per sequence	1	25–24	00	00
Data compression capable	1	23	0	0
Data compression history buffer size	1	22–21	00	–
Data decryption capable	1	20	0	0
Clock synchronization capable	1	19	0	A
Reserved – fabric-specific	1	18–16	000	0
Receive data field size	1	15–0	0800h	256
Concurrent Sequences > 0	2	31–16	00FFh	1
N_Port End-to-end Credit	2	14–0	0000h	–
Open Sequences per Exchange > 0	3	31–16	0001h	1
Class 6 Multicast RX_ID	3	15–0	0000h	–

Class 3 Service Parameters, Fabric Login

TABLE 5-8 Class 3 Service Parameters, Fabric Login

Parameters	Word	Bits	Value	FC-Tape
Class validity	0	31	1	1
Service Options:				
Intermix Mode	0	30	0	–
Stacked Connect Requests	0	29–28	00	–
Sequential Delivery	0	27	1	1
Dedicated Simplex	0	26	0	–
Camp-On	0	25	0	–
Buffered Class 1	0	24	0	–
Reserved	0	23	0	–
Initiator Control:				
Reserved	0	15–0	0000h	–
Recipient Control:				
Reserved	1	31–16	0000h	–
Receive data field size (min, see note)	1	15–0	0000h	256
Concurrent Sequences (min)	2	31–16	0000h	–
N_Port End-to-end Credit	2	15–0	0000h	–
Open Sequences per Exchange (min)	3	31–16	0000h	–
Reserved	3	15-0	0000h	–
Note – This is controlled by a configuration item.				

Other Signalling Formats and Controls

TABLE 5-9 lists other FC-2 features supported by the libraries:

TABLE 5-9 Other FC-2 Features

Feature	FC-Tape		StorageTek
	Initiator	Target	
Addressing Scheme: (see note)			
Node Name Format (registered format)	R	R	Y
Port Name Format (registered format)	R	R	Y
Frame Control (F_CTL):			
Continue Sequence Condition	R	R	00
Continuously increasing sequence count during consecutive sequences within an Exchange	R	R	Y
Ignore non zero Continue Sequence values	A	A	Y
Sequence Chaining (C_S bit in F_CTL = 0)	R	R	Y
Optional Headers (all)	P	P	N
Routing Control (R_CTL):			
FC-4 Device_Data frame	R	R	0000
Extended Link_Data frame	R	R	0010
FC-4 Link_Data Frame	R	R	0011
Video_Data Frame	P	P	0100
Basic Link_Data frame	R	R	1000
Link_Control frame			
Class 2	R	R	1100
Class 3	P	P	1100
X_ID Interlock	–	–	N
Note – Node name and Port name are not identical.			

Link Service Commands

Fibre Channel uses link service commands to manage functions such as port management, Login, Logout, and abort operations. The libraries support both basic and extended link service commands to perform these operations.

Basic Commands

TABLE 5-10 lists the Basic Link Service commands:

TABLE 5-10 Basic Link Services

Command	FC-Tape			StorageTek	
	From Initiator	Target Response	From Target	Lib Orig.	Lib Resp.
No Operation (NOP)	P	–	P	–	N
Abort Sequence (ABTS)	I	R	A	Y	Y
Basic Accept (BA_ACC)	A		R	–	Y
Basic Reject (BA_RJT)	A		R	–	Y
Dedicated Connection Preempted (PRMT)	P	–	P	–	N
Remove Connection (RMC) Class 1	P	–	P	–	N

Extended Commands

TABLE 5-11 lists the Extended Link Service commands:

Note: If the library receives a request for Extended Link Services that are not supported, the library returns a Link Services Command Reject (LS_RJT) with a reason code of “Command Not Supported”.

TABLE 5-11 Extended Link Services

Command	FC-Tape				StorageTek	
	From Initiator	Target Response	From Target	Initiator Response	Lib Orig.	Lib Resp.
Abort Exchange (ABTX)	P		P		N	–
Accept (ACC)	A		R		Y	Y
Advise Credit (ADVC)	P		P		N	–
Discover Address (ADISC)	I	R	P		N	Y
Discover F_Port Parameters (FDISC)	I		I		N	–
Discover N_Port Parameters (PDISC)	I	R	P		–	Y
Echo	P		P		N	–
Establish Streaming (ESTS)	P		P		N	–
Estimate Credit (ESTC)	P		P		N	–
Fabric Activate Alias_ID (FACT)	P		P		N	–
Fabric Address Notification (FAN)	P	P	P	P	N	–

TABLE 5-11 Extended Link Services (Continued)

Command	FC-Tape				StorageTek	
	From Initiator	Target Response	From Target	Initiator Response	Lib Orig.	Lib Resp.
Fabric Deactivate Alias_ID (FDACT)	P		P		N	–
Fabric Login (FLOGI)	R	P	R	P	Y	–
Get Alias_ID (GAID)	P		P		N	–
Link Service Reject (LS_RJT)	A		R		Y	Y
Logout (LOGO)	R	R	R	R	Y	Y
Loop Initialize (LINIT)	I		P		N	Y
Loop Port Control (LPC)	I		P		N	N
Loop Status (LSTS)	I		P		N	N
N_Port Activate Alias_ID (NACT)	P		P		N	–
N_Port Deactivate Alias_ID (NDACT)	P		P		N	–
N_Port Login (PLOGI)	R	R	P		N	Y
Process Login: (PRLI)	R	R	P		N	Y
PRLI Common Service Parameters	P	–	P		N	N
Single Service Parameter page per request	R	R	P		N	Y
Multiple Service Parameter pages per request	P	–	P		N	N
ACC contains only those pages specified	–	R	P		N	Y
Accept Response code of Command executed	–	R	P		N	Y
Process Logout (PRLO)	I	R	I	R	Y	Y
Quality of Service Request (QoSR)	P		P		N	–
Read Connection Status Block (RCS)	P		P		N	–
Read Exchange Concise (REC)	I	R	P		N	Y

TABLE 5-11 Extended Link Services (Continued)

Command	FC-Tape				StorageTek	
	From Initiator	Target Response	From Target	Initiator Response	Lib Orig.	Lib Resp.
Read Exchange Status Block (RES)	P		P		N	–
Read Link Error Status Block (RLS)	I	R	P		N	Y
Request Sequence Initiative (RSI)	A	A	A	A	TBD	TBD
Read Sequence Status Block (RSS)	A	A	A	A	TBD	TBD
Read Timeout Value (RTV)	P		P		N	–
Read VC Status (RVCS)	P		P		N	–
Reinstate Recovery Qualifier (RRQ)	I	R	I	R	Y	Y
Registered State Change Notification (RSCN)	I	R	I	R	N	Y
Report Node Capabilities (RNC)	I	R	P		N	Y
State Change Notification (SCN)	P		P		N	–
State Change Registration (SCR)	I	P	I	P	N	N
Test	P		P		N	–
Test Process Login State	P		P		N	–
Third Party Process Logout (TPRLO)	I	R	P		N	Y

Responses to Link Services

TABLE 5-12 summarizes the response the libraries generate when receiving different Link Service requests when the library NL_Port is not currently logged in with the sending NL_Port.

TABLE 5-12 Response to Link Services from NL_Ports Not Logged-In

Frame Received	NL_Port Not Logged In	NL_Port Logged In	Notes
ABTS	Discard and send LOGO	BA_ACC, BA_RJT	2
ADISC	Discard and send LOGO	ACC and LS_RJT	1
FAN	Process the ELS request, no response required	Process the ELS request, no response required.	
LOGO	ACC	ACC	
PDISC	Discard and send LOGO	ACC and LS_RJT	1
PLOGI	ACC, LS_RJT	ACC	
PRLI	Discard and send LOGO	ACC	
PRLO	Discard and send LOGO	ACC and LS_RJT	3
RSCN	Process the ELS request, no response required.	Process the ELS request, no response required.	
Other Link Services	Discard and send LOGO	ACC and LS_RJT	
<p>Notes:</p> <ol style="list-style-type: none"> All three identifiers must match at login for Accepts (ACC) to be returned: <ul style="list-style-type: none"> N_Port ID, Port Name, and Node Name If all three identifiers do not match, return a logout (LOGO). If other conditions prevent execution of the ADISC or PDICS ELS, return a reject (LS_RJT) with the appropriate reason code. BA_ACC if valid RX_ID else BA_RJT If PRLI has not been successfully completed, set the reason code to "Image Pair Does Not Exist." 			

TABLE 5-13 FC-4 Link Services

Command	FC-Tape				StorageTek	
	From Initiator	Target Response	From Target	Initiator Response	Lib Orig.	Lib Resp.
Sequence Retransmission Request (SRR)	I	R	P		N	N

Frame Format and Header

FIGURE 5-1 shows the frame format for transmission of data and commands over Fibre Channel.

FIGURE 5-1 Frame and Frame Header Format

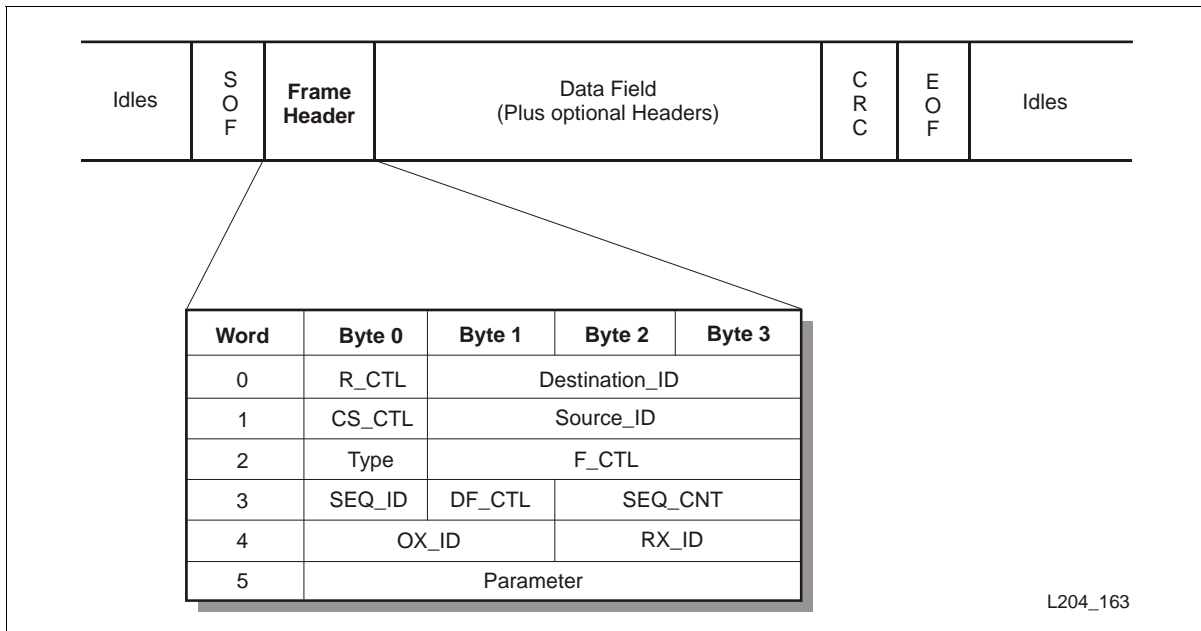

R_CTL	Routing Control: Indicates the type of frame functions
Destination ID	Identifies the port destination
CS_CTL	Class specific control field
Source ID	Identifies the source
Type	Indicates the data structure
F_CTL	Frame Control: Controls information within the frame
SEQ_ID	Sequence Identifier: Identifies sequences within an exchange
DF_CTL	Data Field Control: Indicates optional headers
SEQ_CNT	Sequence Count: Contains frame number within exchange
OX_ID	Originator Exchange ID: Identifies originator of exchange
RX_ID	Responder Exchange ID: Identifies responder of exchange
Parameter	Contains unique parameters for exchange

Exchange Management

Exchange (X) management is the overall control of operations over the Fibre Channel interface between the originator and responder. Refer to the FC-PH documents for rules and guidelines pertaining to Class 2 operation.

Note: For FCP, an exchange is a *single* SCSI command.

There are two fields in the frame header dealing with exchanges:

- OX_ID = Exchange originator
- RX_ID = Exchange responder

TABLE 5-14 Exchange Content Header

Word	Byte 0	Byte 1	Byte 2	Byte 3
0	R_CTL	Destination_ID		
1	CS_CTL	Source_ID		
2	Type	F_CTL		
3	SEQ_ID	DF_CTL	SEQ_CNT	
4	OX_ID		RX_ID	
5	Parameter			

Exchange Originator

The exchange originator assigns a unique OX_ID to the exchange for the transmission of in-order delivery of frames and assumes the frames are processed in the order received. The exchange is open from the time the first frame is sent until one of the following occurs:

- Timeout
- The exchange is aborted (ABTS or ABTX)
- An end-of-frame (EOF) delimiter is sent with the last sequence bit set
- A Logout (LOGO) is sent to or received from the Exchange responder
- A Link Service Command Reject (LS_RJT) is sent in response to an ADISC or PDISC during target discovery
- A PLOGI is sent to the Exchange responder

Exchange Responder

The exchange responders assign unique RX_ID values or use the value of "FFFF." The exchange responder considers an exchange open from the time it receives the first frame of the first information unit until one of the following occurs:

- The last frame of the last information unit is sent with the last sequence bit set
- The exchange is aborted (ABTS)
- A Logout (LOGO) is sent to, or received from, the Exchange originator
- An LS_RJT is sent in response to an ADISC or PDISC during target discovery
- A PLOGI is received

Sequence Management

Sequence management deals with the actual order and transfer of frames across Fibre Channel. The SEQ_ID and SEQ_CNT identify the order of frames for reassembly at the responder.

Refer to the FC-PH documents for rules and guidelines pertaining to Class 2 operation.

TABLE 5-15 Sequence Content Header

Word	Byte 0	Byte 1	Byte 2	Byte 3
0	R_CTL	Destination_ID		
1	CS_CTL	Source_ID		
2	Type	F_CTL		
3	SEQ_ID	DF_CTL	SEQ_CNT	
4	OX_ID		RX_ID	
5	Parameter			

Sequence Open

The library considers a sequence open from the time that the first frame of the sequence (the frame with the SOFi3 delimiter) is sent until one of the following occurs:

- An end-of-frame (EOF) delimiter is sent with the last sequence bit set
- A LOGO is sent to, or received from, the sequence responder
- The sequence is aborted with ABTS

The library as a sequence responder considers a sequence open from the time that the first frame of the Sequence (the frame with the SOFi3 delimiter) is received until one of the following occurs:

- An end-of-frame (EOF) delimiter is sent with the last sequence bit set
- The Sequence is aborted using ABTS
- A LOGO is sent to, or received from, the Sequence originator

Sequence Identifier Usage

The sequence identifier (SEQ_ID) is a field in the frame header that sets one frame apart from another and indicates the order in which frames occur. The following paragraphs summarize the rules governing the reuse of SEQ_IDs.

For sequences which transfer Sequence Initiative:

- An NL_Port can reuse a SEQ_ID for the same Exchange following the confirmation of sequence delivery.
- An NL_Port can reuse the SEQ_ID with a different exchange (to the same, or a different destination NL_Port) immediately following transmission of the last frame of the sequence, without waiting for confirmation of Sequence delivery.

For sequences which do not transfer Sequence Initiative:

- Consecutive FCP_DATA Sequences for the same exchange follow the FC-PH rules for streamed sequences which include:
 - The first FCP_DATA Sequence after transfer of sequence initiative is not a streamed sequence. It can use any eligible SEQ_ID, and the SEQ_CNT can be either zero or a continuously increasing number.
 - The second and subsequent sequences within the same exchange are treated as streamed.
- Because frame delivery is not confirmed, the sequence initiator cannot reuse a SEQ_CNT within a given sequence.

For sequences beginning with a SEQ_CNT of zero, the SEQ_CNT cannot wrap when reaching a hexadecimal count of “FFFF”.

For sequences beginning with a SEQ_CNT of ‘*n*’ (where *n* is not zero), the SEQ_CNT can wrap when reaching a hexadecimal count of “FFFF” and continue from zero up to a value of *n*-1.

Sequence Errors

Sequence errors are managed as defined in FC-Tape with the following additions:

1. If a frame with an SOFi3 delimiter is received and the SEQ_CNT is not equal to zero or +1 from the SEQ_CNT of the last frame of the previous Sequence of that Exchange.
2. If the SEQ_CNT of a received frame with an SOFn3 delimiter is not +1 greater than the previous frame received for that Sequence (such as a frame was lost).
This also detects the case where a frame with an SOFn3 delimiter is received for a SEQ_ID that is not currently open since the SEQ_CNT of the previous frame for that sequence is undefined.
3. If a frame with an SOFi3 delimiter is received and the previous sequence of that exchange is still open.
4. If the relative offset in the parameter field of a received frame with an SOFn3 delimiter is not equal to the (relative offset + the payload size) of the previous frame received for that Sequence.
5. If the next frame of a sequence is not received within E_D_TOV.
6. If, during the same sequence initiative, a sequence is received which has the same SEQ_ID as the previous sequence of that exchange.

When a sequence error is detected by the library, it discards that sequence, and all remaining sequences for the exchange containing the sequence in error. The library attempts to take the appropriate action as defined in FCP-2.

CRC

Fibre Channel adds another level of protection over the content of each frame called a cyclic redundancy check (CRC). Each frame is protected by a 4-byte CRC which provides a separate and independent error detection mechanism.

Timers

Sun StorageTek libraries use the timer values in [TABLE 5-16](#).

TABLE 5-16 Timer Summary

Timer	Value	Implemented By		
		Initiator	Target	StorageTek
AL_TIME	15 ms	R	R	Y
R_T_TOV	100 ms	R	R	Y
E_D_TOV	Private = 2 s	R	A ²	Y
	Public = supplied + 2 s	R	R	Y
R_A_TOV _{SEQ_QUAL}	Private = 0 s Public = 10 s (See note 1)	R	A ²	Y
R_A_TOV _{ELS}	Private = 2 s Public = 10 s	R	R	Y
RR_TOV	300 s		R	Y
REC_TOV	> = E_D_TOV + 1 s minimum	R	R	Y
ULP_TOV	>= Operation specific timer + 4 x REC_TOV	R		N

Notes:

1. The division of R_A_TOV usage differs from the FC-PH because of the unique characteristics of an Arbitrated Loop environment.
2. SCSI target devices that support Class 2 are required to implement this timer.

Arbitrated Loop Timeout

The Arbitrated Loop timeout value (AL_TIME) is two times the worst case round-trip latency of a very large loop.

Receiver_Transmitter Timeout

The Receiver_Transmitter timeout value (R_T_TOV) is used by the receiver logic to detect a loop failure.

Error_Detect Timeout

The Error Detect Timeout value (E_D_TOV) is the maximum time permitted for a Sequence Initiator between the transmission of consecutive data frames within a single sequence. This is also the minimum time that a Sequence Recipient waits for the reception of the next frame within a single sequence before recognizing a Sequence timeout.

E_D_TOV includes the time required to gain access to the loop in addition to the actual frame transmission time.

Resource Allocation Timeouts

The Resource Allocation Timeout (R_A_TOV) has two components:

- Sequence Qualifiers ($_{SEQ_QUAL}$) defines the minimum time that an initiator waits before reusing the sequence qualifiers (SEQ_ID and SEQ_CNT).
- Extended Link Services ($_{ELS}$) determines the minimum time the Originator of an extended link service request waits for the response to a request as a target.

Resource Recovery Timeout

The Resource Recovery timeout (RR_TOV) value is the minimum time the target waits for an initiator to perform an exchange authentication following the completion of the loop initialization.

REC Timeout

The Read Exchange Concise timeout (REC_TOV) is used to time reply sequences and a polling interval for REC error detection. Refer to FCPP-2 for a detailed description.

Upper Level Protocol Timeout

The Upper Level Protocol Timeout (ULP_TOV) is used by the initiator to time the completion of exchanges associated with the Upper Level Protocol operations. The timeout values vary depending on the operations being timed.

FC-3 Common Service Features

TABLE 5-17 lists the Common Service Parameters the libraries support for Port Login (PLOGI):

TABLE 5-17 NL_Port Common Service Parameters, Port Login

Parameter	Word	Bits	StorageTek	FC-Tape
FC-PH Version:				
Highest Version	0	31–24	09h	X
Lowest Version	0	23–16	09h	20h
Buffer-to-Buffer Credit (min.)	0	15–0	0	0
Common Features:	1	31–16		
Continuously Increasing Relative Offset	1	31	1	1
Random Relative Offset	1	30	0	0
Valid Vendor Version Level	1	29	0	0
N_Port/F_Port	1	28	0	0
Alternate BB_Credit Management	1	27	1	–
E_D_TOV Resolution	1	26	0	–
Reserved	1	25–23	0	–
Dedicated Simplex	1	22	0	–
Reserved	1	21–19	0	–
Dynamic Half Duplex – DHD	1	18	0	–
SEQ_CNT	1	17	0	X
Payload Length	1	16	0	–
Buffer-to-Buffer Receive Data Field Size (min.)	1	15–0	0800h	256
Total Concurrent Sequences (min.)	2	31–16	00FFh	1
Relative Offset by Information Category = (Information Category 1 and 5 only)				
	2	15–0	000Fh	0002h
Error Detect Timeout (E_D_TOV) 2 seconds	3	31–0	000007D0h	000007D0h

TABLE 5-18 lists the Common Service Parameters the libraries support for Fabric Login (FLOGI):

TABLE 5-18 NL_Port Common Service Parameters, Fabric Login

Parameter	Word	Bits	StorageTek	NL-Port Originator
FC-PH Version:				
Highest Version	0	31–24	09h	X
Lowest Version	0	23–16	09h	20h
Buffer-to-Buffer Credit (min.)	0	15–0	0	–
Common Features:				
Reserved	1	31–30	0	–
Valid Vendor Version Level	1	29	0	0
N_Port/F_Port	1	28	0	0
Alternate BB_Credit Management	1	27	1	1
Reserved	1	26–19	0	–
Dynamic Half Duplex	1	18	0	–
Reserved	1	17	0	–
Payload Length	1	16	0	–
Buffer-to-Buffer Receive Data Field Size (min., see note)	1	15–0	0800h	256
Reserved	2	31–0	0	–
Reserved	3	31–0	0	–
This is controlled by a configuration item.				

FC-4 (FCP) Features

Fibre Channel Protocol (FCP) provides functions such as login and logout parameters and the transfer of commands and data through the use of Information Units. The FCP command set for the libraries is SCSI-3.

Note – Refer to [Chapter 6, “SCSI Commands”](#) or more information about the implementation of the SCSI-3 command set.

FCP Process Login Parameters

[TABLE 5-19](#) lists Process Login (PRLI) parameters supported:

TABLE 5-19 PRLI Parameters

Feature	FC-Tape		StorageTek
	Initiator	Target	
Command + Data in same Sequence (Write) = 1	P	P	N
Data Overlay Allowed = 1 (see note)	I	R	Y
Data + Response in same Sequence (Read) = 1	P	P	N
Establish Image Pair (bit 13) = 0	I	R	Y
Establish Image Pair (bit 13) = 1	R	R	Y
SRR/REC Recovery Supported = 1	A	R	N
Confirmed Completion Allowed =1	I	R	Y
Initiator Function =1	R	A	N
Originator Process Associator	P	P	N
Originator Process Associator Valid = 1	P	P	N
Responder Process Associator	P	P	N
Responder Process Associator Valid = 1	P	P	N
Read XFER_RDY Disabled = 1	R	R	Y
SCSI Target Function = 1	A	R	Y
Write XFER_RDY Disabled = 1	P	P	N
Note: If the initiator requests it, the use of data overlay is only allowed in response to an SRR (such as with error recovery).			

TABLE 5-20 PRLI Accept FCP Services Parameter Page

FCP Service Parameters	Word	Bits	StorageTek
SCSI FCP (08h)	0	31–24	x'08'
Reserved	0	23–16	0
Originator Process_Associator Valid	0	15	0
Responder Process_Associator Valid	0	14	0
Image Pair Established	0	13	1
Reserved	0	12	0
Accept Response Code	0	11–8	b'0001'
Reserved	0	7–0	0
Originator Process_Associator	1	31–0	0
Responder Process_Associator	2	31–0	0
Reserved	3	31–10	0
Task Retry Identification Requested	3	9	0
Retry	3	8	0
Confirmed Completion Allowed	3	7	0
Data Overlay Allowed	3	6	0
Initiator Function	3	5	0
Target Function	3	4	1
Obsolete	3	3	0
Obsolete	3	2	0
Read FCP_XFER_RDY Disabled	3	1	1
Write FCP_XFER_RDY Disabled	3	0	0

FCP Information Units

Information units transfer data to and from the SCSI initiator and SCSI target and include the following required units:

- T1 = Command and Task Management
- T6 = Write Data (such as Mode Select and Write commands)
- T12 = Response Received Confirmation
- I1 = Transfer Ready on a Write Command
- I3= Read Data (such as Mode Sense and Read commands)
- I4 = Response (such as Status)
- I5 = Response with Confirm Request

FIGURE 5-2 Examples of Read and Write Information Units

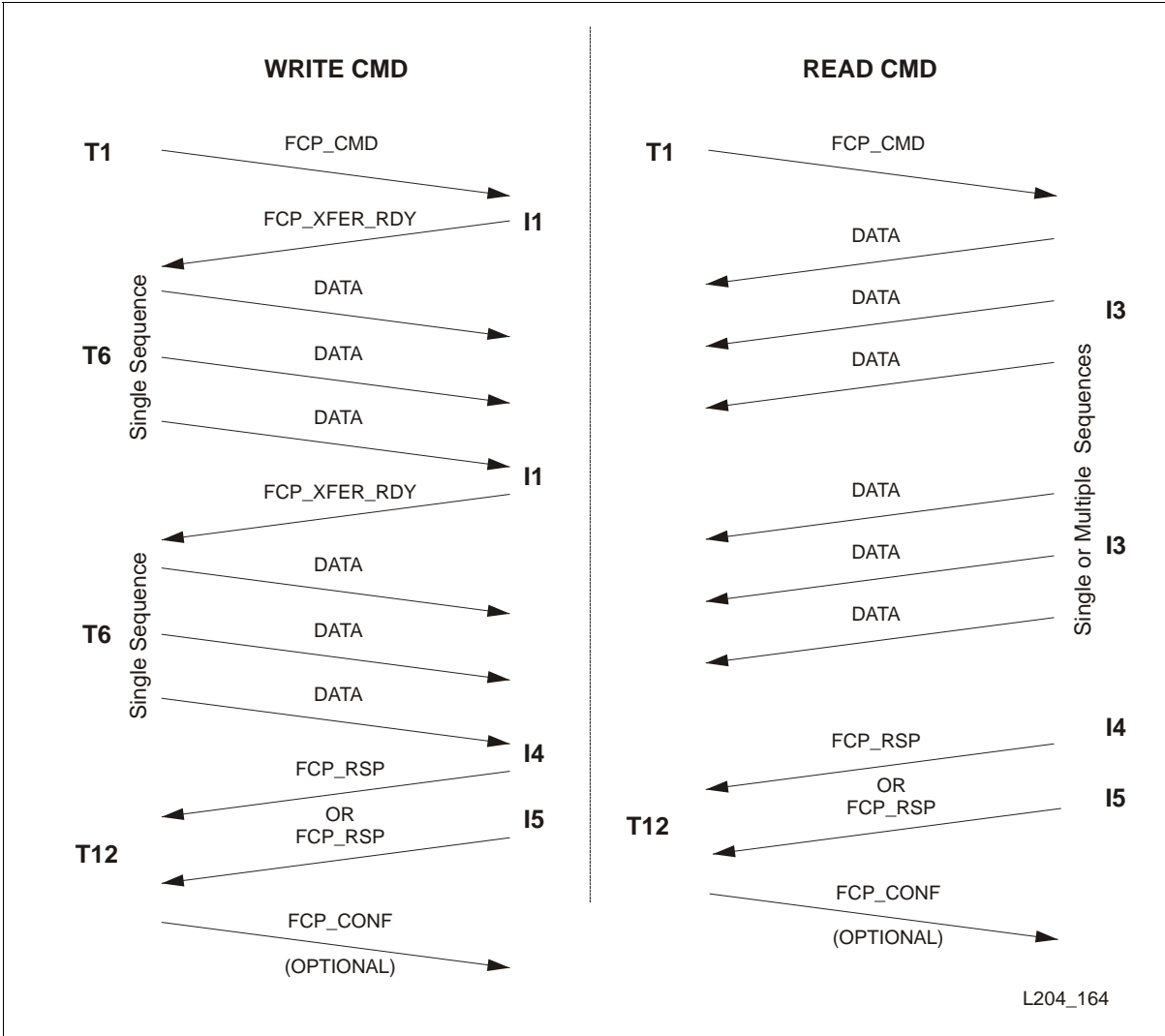

Command Information Unit

The Command Information Unit (T1) is a single-frame sequence.

The library supports the “first level addressing” LUN field as defined in SAM-2. [TABLE 5-21](#) illustrates this.

TABLE 5-21 FCP 8-B byte LUN

Byte 0	Byte 1	Byte 2	Byte 3	Byte 4	Byte 5	Byte 6	Byte 7
00	LUN	00	00	00	00	00	00

For all commands that transfer data to the library:

FCP_DL (data length) in the FCP_CMND payload always equals the number of bytes being transferred for the command.

For SCSI commands that specify the transfer length in blocks in the Command Descriptor Block (CDB), the FCP_DL equals the Transfer_Length multiplied by the Block_Size.

Note: If the FCP_DL value is less than the transfer length, then FCP_DL data will be transferred and the command will be terminated with Check Condition. The Sense Key will be 5h, the ASC will be 4Bh, and the ASCQ will be 80h.

For all commands that transfer data from the library:

The SCSI initiator is responsible for making sure the amount of data returned is equal to the amount specified by FCP_DL—even if Good Status is returned. If the amount does not match FCP_DL, a command-specific Upper Level Protocol recovery action must be invoked. Because there are no transfers of Sequence Initiative during read operations, once the SCSI Target receives the T1 Information Unit, it may return Good Status, even though some of the data was not received by the SCSI initiator. This can occur as the result of lost or corrupted frames in the read data.

Note: The way a SCSI initiator determines the correct amount of data is returned depends on the implementation and includes counting the number of bytes returned and computing the number of bytes received by use of the relative offsets.

The FCP Command Reference Number (CRN) shall be used to ensure proper ordering of Exchange’s (SCSI commands). CRN usage is enabled based on I_T_L nexus by setting the Enable Command Reference Number (ECRN) bit to 1b in the FC Mode Page (19h) for the LUN. Task Management functions shall set the CRN value to 0b. Refer to FCP-2 (4.3 Precise Delivery of SCSI Commands) for a detailed description.

Note: The library currently does not support command queuing; thus CRNs are not supported.

Transfer Ready Information Units

The Transfer Ready Information Unit (I1) is a single-frame sequence.

For write operations:

The FCP_XFER_RDY is sent before each write data sequence.

For read operations:

The FCP_XFER_RDY IU (I2) is not used during read type (data in) operations. This is indicated by setting the 'READ XFER_RDY DISABLED' bit during process login.

Data Information Unit

The Data Information Units (T6 and I3) are either single- or multiple-frame sequences.

The FCP_DATA IU transfers data associated with an operation. This data includes command parameter data (such as Mode Select data) or command response data (such as Mode Sense data).

Response Information Unit

The Response Information Units (I4) are single- or multiple-frame sequences.

The first two bits (30 and 31) of the first word of a command status frame payload fall into the following categories:

- 00 = Successful and complete
- 01 = Successful but incomplete
- 10 = Unsuccessful but complete
- 11 = Unsuccessful and incomplete

Because the first word of FCP_RSP frames are reserved in FCP, these bits are set to 0b, regardless of the content of the SCSI Status portion of the payload. SCSI initiators do not rely on word 0, bits 31 and 30 in FCP_RSP to determine success or completion status of a command. An FCP_RSP following a data-in sequence (I3) may or may not be treated as a streamed sequence.

Residual Checking

Residual checking falls under the following categories:

- SCSI targets that transfer exactly FCP_DL data bytes during the FCP_DATA IUs set the FCP_RESID_UNDER to a value of 0b.

When FCP_RESID_UNDER is set to 0b, the SCSI initiator tries to determine if all of the expected data was transferred by comparing the FCP_DL to the actual number of bytes transferred. If these values are not the same, the ULP is notified so that the appropriate action can be taken.

- SCSI targets that transfer less than FCP_DL data bytes during the FCP_DATA IUs set the FCP_RESID_UNDER to a value of 1b.

If the FCP_RESID_UNDER bit is set to 1b, a transfer that did not fill the buffer to the expected displacement. Failure to transfer FCP_DL bytes does not necessarily indicate an error for some devices and commands.

- If the FCP_RESID_OVER bit is set, the transfer was truncated because the data transfer required by the SCSI command extended beyond the displacement value of FCP_DL. Those bytes that could be transferred without violating the FCP_DL value may or may not have been transferred.
- Commands that do not contain an FCP_DATA IUs, FCP_RESID_UNDER and FCP_RESID_OVER are set to 0b, and the value of the FCP_RESID is undefined.

Response Payload

TABLE 5-22 lists the FCP_RSP payload fields:

TABLE 5-22 FCP_RSP Payload

Feature	FC-Tape		StorageTek
	Initiator	Target	
FCP_CONF_REQ	A	R	Y
FCP_SNS_INFO	R	I	Y
FCP_SNS_LEN (total)	R	≤ 128	20
FCP_SNS_LEN_VALID	R	I	Y
Length of Additional Sense Bytes in FCP_SNS_INFO	R	≤ 120	16
FCP_RSP_INFO	R	I	Y
FCP_RSP_LEN	R	0 or 8	8
FCP_RSP_LEN_VALID	R	I	Y
FCP_RESID	R	R	Y
FCP_RESID_OVER	R	I	Y
FCP_RESID_UNDER	R	I	Y

Response Codes

The Response Code field (FCP_RSP_INFO) contains information that describes the failures detected during the execution of an I/O operation and conforms to the following rules:

- The FCP_RSP_INFO does not contain link error information because FC-PH provides the mechanisms for presenting these errors.
- The FCP_RSP_INFO does not contain SCSI logical unit error information because that information is in the FCP_STATUS and FCP_SNS_INFO fields.
- RSP_CODE values of 04h and 05h are not valid responses to SCSI commands. The RSP_CODE is independent of the SCSI Status and should be examined before interpretation of the SCSI Status.
- For other non-zero values of the RSP_CODE, the SCSI Status may not be valid.

TABLE 5-23 indicates the result of a Task Management function in the RSP_CODE of the FCP_RSP_INFO fields.

TABLE 5-23 FCP_RSP Code

RSP_CODE	Description
00	No failure or Task Management complete
01	FCP_DATA length different than BURST_LEN
02	FCP_CMND fields invalid
03	FCP_DATA RO mismatch with FCP_XFER_RDY DATA_RO
04	Task Management function not performed or supported
05	Task Management function supported but not performed
06-FF	Reserved

The FCP_CONF IU is used by the target to confirm reception of an FCP_RSP IU at the initiator. Support for the FCP_CONF IU is negotiated via PRLI. A target request for an FCP_CONF IU from the initiator is indicated by the target setting the FCP_CONF_REQ bit in the FCP_STATUS field contained in the FCP_RSP. If the initiator does not need to perform any error detection or recovery procedure, the initiator will send an FCP_CONF IU if an FCP_RSP is received with the FCP_CONF_REQ bit set in the FCP_STATUS field.

The initiator will release Exchange information such as the Exchange Status Block (ESB) after the FCP_CONF is sent. The target will retain Exchange information and associated data until an FCP_CONF is received. See FCP-2 (4.4 Confirmed Completion of FCP-2 SCSI Commands) for a description of the FCP_CONF_REQ bit and FCP_CONF usage.

The following lists each command and its supported usage of requesting an FCP_CONF:

No confirm	The library will not set the FCP_CONF_REQ bit in the response to the command. As soon as the response has been transmitted, the exchange is terminated, and there is no FCP-2 Link Level error recovery possible.
Implicit confirm	The library does not set the FCP_CONF_REQ bit in the response to the command. However, the exchange is not terminated until the same initiator sends the next command or until the Resource Recovery timer expires on this exchange. This will allow the initiator to do FCP-2 Link Level error recovery, if necessary, before sending the next command.
Explicit confirm	The library will set the FCP_CONF_REQ bit in the response to a command if the condition in this column is met. This will allow the initiator to do FCP-2 Link Level error recovery, if necessary, before sending the FCP_CONF. If the initiator does not support FCP_CONF, as indicated in its PRLI payload, then the library will not set the FCP_CONF_REQ bit, regardless of the condition being met. But the library will treat it as an Implicit Confirm condition.

TABLE 5-24 Command Confirmation Usage

Command	No Confirm	Implicit Confirm	Explicit Confirm
Library Motion			
Move Medium	If not, check	Always	Check condition
Position to Element	Always		
Non-Customer Data			
Inquiry	Always		
Log Sense	Always		
Mode Select	Always		
Mode Sense	Always		
Persistent Reserve In	Always		
Persistent Reserve Out	Always		
Read Element Status	Always		
Reported LUNs	Always		
Request Sense	Always		
Request Volume Element Address	Always		
Write Buffer	Always		
Misc.	Always		
Initialize Element Status	Always		
Initialize Element Status with Range	Always		
Prevent/Allow Medium Removal	Always		
Release	Always		
Reserve	Always		
Send Diagnostic	Always		
Send Volume Tag	Always		
Test Unit Ready	Always		
Notes:			
1. Commands that report Check Condition with the Response Code of Deferred Error (71h) will follow the rules of Explicit Confirm.			
2. Any command which responds with Check Condition of Overlapped Commands Attempted (Sense Key = Bh, ASC/ASCQ = 4E00h) will follow the rules of Explicit Confirm.			

Task Management Flag and Information Units

All SCSI initiators send Task Management functions using T1.

All SCSI targets return FCP_RSP to Task Management functions using I4.

The RSP_CODE in the FCP_RSP_INFO field indicates the result of the Task Management function. The SCSI Status byte and FCP_SNS_INFO are ignored for I4 information units sent in response to a Task Management function.

TABLE 5-25 lists the Task Management Flags the libraries support:

TABLE 5-25 FCP Task Management Flags

Feature	FC-Tape		StorageTek
	Initiator	Target	
Terminate Task = 1	P	P	N
Clear ACA = 1 (command queuing)	R	R	N
Clear ACA = 1 (no command queuing)	P	P	N
Target Reset = 1	I	R	Y
Clear Task Set = 1	I	R	Y
Abort Task Set = 1	I	R	Y
Logical Unit Reset = 1	I	R	Y

Task Attributes

TABLE 5-26 lists the FCP Task Attributes supported by the libraries:

TABLE 5-26 FCP Task Attributes

Feature	FC-Tape		StorageTek
	Initiator	Target	
Untagged	R	R	Y
Simple Queue Type (depth = 1)	I	A	Y
Ordered Queue Type	I	A	N
Head of Queue Type	I	A	N
Auto Contingent Allegiance Type	I	A	N

Other Features

TABLE 5-27 lists other FCP features supported:

TABLE 5-27 Other FCP Features

Feature	FC-TAPE		StorageTek
	Initiator	Target	
FCP_LUN (in FCP_Command)	R	R	Y
FCP_LUN (0)	I	R	Y
Inquiry of FCP_LUN (0)	I	R	Y
Inquiry of FCP_LUN (>0)	I	R	Y
Auto Contingent Allegiance (ACA)	A	A	N

Public Loop SCSI Target Discovery

For public loop SCSI target discovery, the following private loop discovery is used except that discovery of SCSI targets will be performed via the Simple Name Server or RSCN, and the function performed by ADISC/PDISC will be replaced by FAN.

Private Loop SCSI Target Discovery

When the possibility of a configuration change exists, a SCSI initiator might want to rediscover the new configuration. The SCSI Target Discovery procedure for a SCSI initiator is:

For all valid AL_PAs:

```

OPN(AL_PA)
  IF OPN is successful, then
    Send ADISC or PDISC to D_ID = hex '0000' || AL_PA
    IF LOGO is returned or the Node Name or Port Name has changed, then
      Send PLOGI to D_ID = hex '0000' || AL_PA
      IF PLOGI is successful, then
        IF no hard address conflicts or application tolerant of hard address conflicts
          Send PRLI to D_ID = hex '0000' || AL_PA
          IF PRLI is successful, then
            Send FCP_CMND with INQUIRY CDB to D_ID = hex '0000' ||AL_PA(LUN_0)
          ENDIF
        ENDIF
      ENDIF
    ENDIF
  ENDIF
NEXT AL_PA

```

To determine if an OPN was “successful,” the NL_Port must be able to:

1. Detect when an OPN has not been intercepted by the designated AL_PA.
2. Detect that an R_RDY or CLS has not been received from the AL_PA specified in an OPN within E_D_TOV of sending that OPN.
3. Detect that a CLS was received in response to the OPN.
In this case, the Target Discovery procedure should be retried at a later time.
4. Detect that the OPN or frame Extended Link Service failed.

If the SCSI Target Discovery procedure revealed a Hard Address conflict (such as an NL_Port was unable to acquire its hard address), then the application may choose to operate in spite of that conflict.

If this is the case, then the discovery procedure can continue with the PRLI and subsequent SCSI INQUIRY command.

If the application is not tolerant of Hard Address conflicts, the SCSI initiator may choose not to use that NL_Port.

Using this SCSI Target Discovery procedure, the SCSI initiator has the ability to assemble a database consisting of Node name, Port name, and N_Port ID.

There are several confirmations a SCSI initiator can perform on that database to determine which SCSI targets it can continue to communicate with, but this document does not define them.

Note: Not all initiators perform the exact steps described in the above algorithm. However, a SCSI initiator is required to issue ADISC or PDISC to all SCSI targets it is logged in with within RR_TOV of receiving LIP if it wants to remain logged in with those SCSI Targets.

The ADISC/PDISC procedure is designed to avoid the abnormal termination of all open Exchanges when a new device is attached to the loop or when a device powers on.

Note: Because devices are not required to respond to Class 3 frames that have a D_ID that does not match the full 24-bit N_Port identifier of the receiving NL_Port, timeouts might occur during the SCSI target discovery process if a SCSI initiator sends a frame to a Public NL_Port using a D_ID of 0000h || AL_PA or to a Private NL_Port using a D_ID with the upper 16 bits non-zero. Therefore, for performance reasons, SCSI initiators should originate PDISC or ADISC Exchanges by transmitting the ELS Sequence, without waiting for the response. SCSI initiators might need to originate multiple concurrent Exchanges to hide multiple timeouts from the user.

Clearing the Effects of Fibre Channel Actions

TABLE 5-28 lists the clearing effects of ULP, FCP, FC-PH, and FC-AL Fibre Channel actions:

TABLE 5-28 Clearing Effects

FCP SCSI Target Object	Power On Reset	LIP Reset	LOGO PLOGI	ABTS	PRLI PRLO	TPRLO	SCSI Target Reset	Clear Task Set	Abort Task Set	SCSI Log. Unit Reset
PLOGI parameters:										
All logged-in initiators	Y	Y	N	N	N	N	N	N	N	N
Only ports initiating action	-	-	Y	N	N	N	N	N	N	N
Open sequences terminated:										
For all initiator with OPN seq's	Y	Y	N	N	N	Y	Y	Y	N	Y
Only ports initiating action	-	-	Y	N	Y	-	-	-	Y	-
Only for seq. with aborted exchange	-	-	-	Y	-	-	-	-	-	-
Login BB_Credit_CNT:										
All logged-in L_Ports	Y	Y	-	N	N	N	N	N	N	N
Only transmitting ports	-	-	Y							
Hard address acquisition attempted	Y	Y	N	N	N	N	N	N	N	N
PRLI parameters cleared:										
All logged-in initiators	Y	Y	N	N	N	N	N	N	N	N
Only ports of specific type	-	-	N	N	Y	Y	N	N	N	N
Only ports initiating action	-	-	Y	N	Y	N	N	N	N	N
Open exchanges aborted:										
All tasks, all initiators, open tasks	Y	Y	N	N	N	Y	Y	Y	N	Y
All tasks, port initiating action	-	-	Y	N	Y	-	-	-	Y	-
Specific task, port initiating action	-	-	N	Y	N	-	-	-	N	-
SCSI target mode page parameters restored from saved pages:										
All initiators	Y	Y	N	N	N	Y	Y	N	N	Y
Only ports initiating action	-	-	Y	N	Y	-	-	N	N	-

TABLE 5-28 Clearing Effects (Continued)

FCP SCSI Target Object	Power On Reset	LIP Reset	LOGO PLOGI	ABTS	PRLI PRLO	TPRLO	SCSI Target Reset	Clear Task Set	Abort Task Set	SCSI Log. Unit Reset
Pre-existing ACA, UA, and deferred error conditions cleared:										
All initiators	Y	Y	N	N	N	Y	Y	N	N	Y
Only ports initiating action	-	-	Y	N	Y	-	-	N	N	-
Device Reservations										
For all SCSI initiators	Y	Y	N	N	N	Y	Y	N	N	Y
Only for SCSI initiator port initiating action	-	-	Y	N	Y	-	-	N	N	-
Persistent Device Reservations										
For all SCSI initiators	Y	N	N	N	N	N	N	N	N	N
Only for SCSI initiator port initiating action	-	-	N	N	N	-	-	N	N	-
CRN (Command Reference Number)										
For all SCSI initiators	Y	Y	N	N	N	Y	Y	N	N	Y
Only for SCSI initiator port initiating action	-	-	Y	N	Y	-	-	N	N	-
Prevent Allow Medium Removal state										
For all SCSI initiators	Y	Y	N	N	N	Y	Y	N	N	Y
Only for SCSI initiator port initiating action	-	-	N	N	Y	-	-	N	N	-
Exchange Information										
For all SCSI initiators	Y	Y	N	N	N	Y	Y	N	N	Y
Only for SCSI initiator port initiating action	-	-	Y	N	Y	-	-	N	N	-

Device Reservations

The SL500 tape library support the Reserve/Release management method and also the Persistent Reservations management method. These methods are defined in the ANSI SCSI-3 Primary Commands (SPC-2) standard. For the reservation restrictions placed on commands for the Reserve/Release management method, see [TABLE 5-29](#). For the reservation restrictions placed on the Persistent Reservations management method, see [TABLE 5-30 on page 83](#).

Conflict	Command will not be performed and the library will terminate the command with Reservation Conflict status.
Allowed	Command will be allowed to execute to normal completion.

TABLE 5-29 Reserve/Release Management Method

Command	Action when Reserved by a different Initiator
Initialize Element (07h)	Conflict
Initialize Element with Range (37h)	Conflict
Inquiry (12h)	Allowed
Log Sense (4Dh)	Allowed
Mode Select (15h/55h)	Conflict
Mode Sense (1Ah/5Ah)	Conflict
Move Medium (A5h)	Conflict
Persistent Reserve In (5Eh)	Conflict
Persistent Reserve Out (5Fh)	Conflict
Position to Element (2Bh)	Conflict
Prevent/Allow Removal (1Eh)	Prevent = 0, allowed Prevent = NZ, conflict
Read Element Status (B8h)	Conflict
Release Unit (17h/57h)	Allowed, the reservation is not released.
Reported LUNs (A0h)	Allowed
Request Sense (03h)	Allowed
Request Volume Element Address (B5h)	Conflict
Reserve Unit (16h/56h)	Conflict
Send Diagnostic (1Dh)	Conflict
Send Volume Tag (B6h)	Conflict
Test Unit Ready (00h)	Conflict
Write Buffer (3Bh)	Conflict

TABLE 5-30 Persistent Reservation Management Method

Command	From Non-registered Initiators	From Registered Initiators
Initialize Element (07h)	Conflict	Allowed
Initialize Element with Range (37h)	Conflict	Allowed
Inquiry (12h)	Allowed	Allowed
Log Sense (4Dh)	Allowed	Allowed
Mode Select (15h/55h)	Conflict	Allowed
Mode Sense (1Ah/5Ah)	Conflict	Allowed
Move Medium (A5h)	Conflict	Allowed
Persistent Reserve In (5Eh)	Allowed	Allowed
Persistent Reserve Out (5Fh)	Register, allowed Reserve, conflict Release, conflict Clear, conflict Preempt, conflict Pre/Abt, conflict Reg/Ign, allowed	Register, allowed Reserve, conflict Release, allowed Clear, allowed Preempt, allowed Pre/Abt, allowed Reg/Ign, allowed
Position to Element (2Bh)	Conflict	Allowed
Prevent/Allow Media Removal (1Eh)	Prevent = 0, allowed Prevent = NZ, conflict	Allowed
Read Element Status (B8h)	Conflict	Allowed
Release Unit (17h/57h)	Conflict	Conflict
Reported LUNs (A0h)	Allowed	Allowed
Request Sense (03h)	Allowed	Allowed
Request Volume Element Address (B5h)	Conflict	Allowed
Reserve Unit (16h/56h)	Conflict	Conflict
Send Diagnostic (1Dh)	Conflict	Allowed
Send Volume Tag (B6h)	Conflict	Allowed
Test Unit Ready (00h)	Conflict	Allowed
Write Buffer (3Bh)	Conflict	Allowed

Command Set

This chapter lists and describes the small computer system interface command set and structures for the SL500 library.

[TABLE 6-5 on page 88](#) contains a list of the commands, command codes, and page numbers that contain a description of the command.

Note – This manual does not describe the commands for tape drives. Refer to the tape drive documentation for information about SCSI commands for a tape drive.

Implementation Requirements

The structure for all command descriptor blocks is:

The first byte contains a:

- Group Code that provides 8 groups of commands
- Command Code that provides 32 command codes for each group

The second byte in all command descriptor blocks:

- Starts the command parameters

Additional bytes:

- Contains command parameters

Last byte in all command descriptor blocks:

- Control byte

Note – The library is SCSI-3 compliant.

For some commands, a list of parameters accompanies the request during Data Out.

For all commands, if there is an invalid parameter in the command descriptor block, then the device terminates the command without altering the medium.

Command Descriptor Block

Initiators use three types of CDBs to communicate commands to the targets:

- 6-Byte commands (TABLE 6-1)
- 10-Byte commands (TABLE 6-2)
- 12-Byte commands (TABLE 6-3)

The first byte in the command descriptor block contains an operation code.

TABLE 6-1 6-Byte Command Descriptor Block

Byte	Bit							
	7	6	5	4	3	2	1	0
0	Group Code			Command Code				
1	Reserved			Command Parameters				
2-4	Command Parameters							
5	Control Byte							

TABLE 6-2 10-Byte Command Descriptor Block

Byte	Bit							
	7	6	5	4	3	2	1	0
0	Operation Code							
1	Reserved			Command Parameters				
2-8	Command Parameters							
9	Control Byte							

TABLE 6-3 12-Byte Command Descriptor Block

Byte	Bit							
	7	6	5	4	3	2	1	0
0	Operation Code							
1	Reserved			Command Parameters				
2-9	Command Parameters							
10	Reserved							
11	Control Byte							

Control Byte

The control byte is the last byte of every Command Descriptor Block and has the following structure:

TABLE 6-4 Control Byte

Byte	Bit							
	7	6	5	4	3	2	1	0
5, 9, or 12	Vendor Specific		Reserved			NACA (0)	Flag (0)	Link (0)

- **Vendor Specific**
Provides additional information about the device or for a command.
- **NACA**
The normal auto contingent allegiance bit controls the rules for handling an auto contingent condition caused by a command. This bit is set to 0 to indicate that if a contingent allegiance condition occurs, the command will return a check condition.
- **Flag (not supported)**
This bit causes an interrupt in the initiator allowing a device to respond with intermediate status. This bit is not supported and should be 0.
- **Link (not supported)**
Allows devices that support command linking to continue the I/O process. This bit is not supported and should be 0.

List of Supported Commands

TABLE 6-5 Supported Commands

Command and Page Number	Hex Code
Initialize Element Status on page 90	07
Initialize Element Status With Range on page 91	37
Inquiry on page 92	12
Log Sense on page 99	4D
Mode Select (6) on page 105	15
Mode Select (10) on page 116	55
Mode Sense (6) on page 127	1A
Mode Sense (10) on page 142	5A
Move Medium on page 167	A5
Persistent Reserve In on page 169	5E
Persistent Reserve Out on page 175	5F
Position to Element on page 179	2B
Prevent/Allow Medium Removal on page 180	1E
Read Element Status on page 181	B8
Release (6) on page 204	17
Release (10) on page 205	57
Report LUNS on page 206	A0
Request Sense on page 208	03
Request Volume Element Address on page 219	B5
Reserve (6) on page 222	16
Reserve (10) on page 225	56
Send Diagnostic on page 227	1D
Send Volume Tag on page 229	B6
Test Unit Ready on page 231	00
Write Buffer on page 232	3B

Operator Entries for Fibre Channel

The Fibre Channel interface requires configuration of the library's Port 0 address. You may configure the library for soft or hard addressing of this port.

If you configure the library for hard addressing, you may input the Port 0 address yourself through the library's operator panel or through the library's StreamLine Library Console (SLC) if used. Allowable loop addresses are 000d to 125d.

Note – Before you input a Port 0 address, you must first set the library's Fibre Channel hard address option to *enabled*.

If you configure the library for soft addressing, you are allowing the Fibre Channel software to configure the Port 0 address. Addresses are assigned in ascending order. For this addressing approach, you must *disable* the Fibre Channel hard address option.

Note – The default for the hard address option is *disabled*. See the library operator's guide for additional instructions on setting these values.

Initialize Element Status

The host uses the Initialize Element Status command (07h) to request an inventory of the cartridge tapes held in the library. The library accepts this command for compatibility, but does not perform any action.

At power-on the library performs an audit of and maintains the inventory during operations. The library also performs an audit after someone has opened and closed the front door.

An initiator can obtain inventory information for the library by using the Read Element Status command.

TABLE 6-6 Initialize Element Status Command

Byte	Bit							
	7	6	5	4	3	2	1	0
0	Operation Code (07h)							
1	Ignored			Reserved (00h)				
2	Reserved (00h)							
3	Reserved (00h)							
4	Reserved (00h)							
5	Control Byte (00h)							

Initialize Element Status With Range

The Initialize Element Status With Range command (37h) is a request from the host to perform an inventory of a portion of the cartridge tapes within the library. The library accepts this command for compatibility, but does not perform any action.

At power-on the library performs an audit of and maintains the inventory during operations. The library also performs an audit after someone has opened and closed the front door.

An initiator can obtain inventory information for the library by using the Read Element Status command.

TABLE 6-7 Initialize Element Status With Range Command

Byte	Bit							
	7	6	5	4	3	2	1	0
0	Operation Code (37h)							
1	Ignored			Reserved (00h)			Fast	Range
2 to 3	(MSB) Element Address							(LSB)
4 to 5	(MSB) Reserved (00h)							(LSB)
6 to 7	(MSB) Number of Elements							(LSB)
8	Reserved (00h)							
9	Control Byte (00h)							

Initialize Element Status with Range Definitions:

Fast	Ignore this field.
Range	Ignore this field.
Element Address	Ignore this field.
Number of Elements	Ignore this field.

Inquiry

The Inquiry command (12h) requests that the library send to the initiator information regarding the library's parameters.

TABLE 6-8 Inquiry Command

Byte	Bit							
	7	6	5	4	3	2	1	0
0	Operation Code (12h)							
1	Ignored			Reserved (00h)			CmdDt (0)	EVPD
2	Page Code							
3 to 4	MSB Allocation Length							LSB
5	Control Byte (00h)							

Inquiry Command Definitions:

CmdDt	Command support data is not supported (0).
EVPD	The enable vital product data bit indicates the type of inquiry data the initiator is requesting. Supported values are: <ul style="list-style-type: none"> ■ 0 = Request for standard inquiry data ■ 1 = Request for vital support product data page
Page Code	If the EVPD value is 0, this field is set to 00h. If the EVPD value is 1, this field must be: <ul style="list-style-type: none"> ■ 00h = Supported vital product pages ■ 80h = Unit serial number page ■ 83h = Device identification page (Fibre only)
Allocation Length	The allocation length field specifies the number of bytes the initiator has allocated for data returned from the Inquiry command. A value of 0 indicates that no inquiry data is to be transferred. This condition is <i>not</i> considered an error.

The library terminates the Data In phase when it has transferred either the number of bytes specified by the Allocation Length field or all of the available inquiry data, whichever is less.

- The data length for the standard inquiry data the library returns is 24h (36d) bytes.
- The data length for page 0 is 07h (7d) for fibre and 06h (6d) for LVD.
- The data length for the unit serial number page (80h) is 0fh (15d) bytes.
- The data length for the device identification page (83h) is 20h (32d).

Note – The Inquiry command returns check condition status only when the requested data cannot be returned. This command will not clear any pending unit attention conditions.

Standard Inquiry Data Definition

For the Inquiry command, the library returns 24h (36d) bytes of data in this format.

TABLE 6-9 Standard Inquiry Data

Byte	Bit							
	7	6	5	4	3	2	1	0
0	Peripheral Qualifier			Peripheral Device Type				
1	RMB (1)	Reserved (0)						
2	Version (05h)							
3	Reserved (0)		Norm ACA (0)	HiSup (1)	Response Data Format (2)			
4	Additional Length (n-4)							
5	SCCS (0)	ACC (0)	TPGS (0)		3PC (0)	Reserved		Protect (0)
6	BQue (0)	EncServ (0)	VS (0)	MultiP (0)	MChngr (0)	Reserved (0)		ADDR16 ^a (1)
7	Rsvd (0)	Rsvd (0)	WBUS16 ^a	SYNC ^a	LINKED (0)	Rsvd (0)	CmdQue (0)	SftRe (0)
8 to 15	(MSB) Vendor Identification							(LSB)
16 to 31	(MSB) Product Identification							(LSB)
32 to 35	(MSB) Product Revision Level							(LSB)
Note – ^a The meaning of these fields are specific to the SCSI Parallel Interface (SPI-5). For protocols other than the SCSI Parallel Interface (such as Fibre Channel), these fields are reserved.								

Standard Inquiry Data Definitions:

Peripheral Qualifier	The library returns a value of 000b indicating the specified peripheral device type is currently connected to this logical unit. If the command is sent to an unsupported logical unit, the value returned is 011b. (b = binary notation)
Peripheral Device Type	The library returns a value of 8h, which indicates that the library is a medium changer device. If the command is sent to an unsupported logical unit, the value returned is 1Fh.
RMB	Removable Medium; a value of 1 indicates the medium is removable.
Version	The library returns a value of 5h, which indicates compliance to SCSI-3
NormACA	The Normal Auto Contingent Allegiance (NACA) bit controls the rules for handling an auto contingent condition caused by a command. The library returns a value of 0, indicating it does not support setting the NACA bit to one in the control byte of a CDB.

HiSup	The library returns a value of 1, indicating the library uses the hierarchical addressing model to identify logical units.
Response Data Format	A value of 2 indicates the data found is in accordance with the SCSI-3 specification.
Additional Length	A value of 1Fh indicates there are 31 additional bytes of Standard Inquiry Data available to the initiator.
SCCS	The library returns a value of 0, indicating the library does not contain an embedded storage array controller component.
ACC	The library returns a value of 0, indicating it does not contain an access control coordinator that may be addressed through this logical unit.
TPGS	The Target Port Group Support (TPGS) field returns a value of 0 indicating that the library does not support asymmetric logical unit access. Neither of the Report Target Groups or Set Target Groups commands are supported.
3PC	The library returns a value of 0, indicating third-party commands are not supported.
Protect	The library returns 0 indicating that it does not support protection information.
BQUE	The library returns a value of 0, indicating basic queuing is not supported.
VS	Vendor Specific bit is set to 0, indicating there is no vendor-specific information with this command.
MultiP	The library returns a value of 0, indicating multi-port attachments are not supported.
MChngr	The library is not embedded in or attached to a medium transport element and returns a value of 0.
ADDR16^a	The library returns a value of 1 for the wide SCSI address 16 bit, indicating 16-bit wide SCSI addresses are supported.
WBUS16^a	<ul style="list-style-type: none"> ■ 0 = The library does not support 16-bit wide data transfers ■ 1 = The library supports 16-bit wide data transfers
SYNC^a	<ul style="list-style-type: none"> ■ 0 = The library does not support synchronous data transfer ■ 1 = The library supports synchronous data transfer
LINKED	The library returns a value of 0 for the LINKED command bit, indicating linked commands are not supported.
CmdQue	The library returns a value of 0, indicating Command Queuing is not supported.
SftRe	The library returns a value of 0, indicating Soft Reset is not supported.
Vendor Identification	Contains the ASCII character sequence "STK" followed by blanks. If the specified logical unit is not supported, this field contains all blanks.
Product Identification	This field contains the ASCII character sequence "SL500" followed by blanks.
Product Revision Level	This field contains an ASCII character sequence that represents the product revision level.

Error Conditions:

- The library returns Check Condition status for the Inquiry command only when a severe error occurs. To recover from a Check Condition status report on the Inquiry command, verify that the Inquiry CDB is OK, and retry the Inquiry command.

Supported Pages Definition

The library returns the following bytes of supported page data in this format.

- 6 bytes for LVD SCSI
- 7 bytes for Fibre Channel

TABLE 6-10 Supported Pages

Byte	Bit							
	7	6	5	4	3	2	1	0
0	Peripheral Qualifier			Peripheral Device Type				
1	Page Code (00h)							
2	Reserved (00h)							
3	Additional Page Length (03h for Fibre, 02h for LVD)							
4	Supported Page (00h)							
5	Supported Page (80h)							
6	Supported Page (83h) - Fibre only							

Supported Pages Definitions:

Peripheral Qualifier	The library returns a value of 000b indicating the specified peripheral device type is currently connected to this logical unit. If the command is sent to an unsupported logical unit, the value returned is 011b. (Note: xxxb indicates binary notation).
Peripheral Device Type	The library returns a value of 8h, which indicates that the library is a medium changer device. If the command is sent to an unsupported logical unit, the value returned is 1Fh.
Page Code	Identifies the page as the supported pages (00h).
Additional Page Length	Indicates the remaining bytes in the data: <ul style="list-style-type: none"> ■ 02h = LVD SCSI ■ 03h = Fibre Channel
Supported Page	<ul style="list-style-type: none"> ■ 00h = Indicates the first vital page is page 0 (current page) ■ 80h = Indicates the second vital page unit serial number, on page 96 ■ 83h = Indicates the third vital page device identification, on page 97 (Fibre only)

Unit Serial Number Page Definition

The library returns 10h (16d) bytes of unit serial number page data in this format.

TABLE 6-11 Unit Serial Number Page

Byte	Bit							
	7	6	5	4	3	2	1	0
0	Peripheral Qualifier				Peripheral Device Type			
1	Page Code (80h)							
2	Reserved (00h)							
3	Additional Page Length (0Ch)							
4 to 15	(MSB)	Unit Serial Number						(LSB)

Unit Serial Number Page Definitions:

Peripheral Qualifier	The library returns a value of 000b indicating the specified peripheral device type is currently connected to this logical unit. If the command is sent to an unsupported logical unit, the value returned is 011b. (Note: xxxb indicates binary notation).
Peripheral Device Type	The library returns a value of 8h, which indicates that the library is a medium changer device. If the command is sent to an unsupported logical unit, the value returned is 1Fh.
Page Code	This field is set to 80h, identifying the page as the unit serial number page.
Additional Page Length	This field is set to 0Ch, the number of bytes in the product serial number.
Unit Serial Number	This field contains a unique 12-character ASCII identifier for the library. <ul style="list-style-type: none"> ■ For example: 522XX0000121 Where: XX indicates the library partition number. For non-partitioned libraries, XX is 00.

Device Identification Page

The library returns 36d bytes of device identification page data in this format:

TABLE 6-12 Device Identification Page Data

Byte	Bit								
	7	6	5	4	3	2	1	0	
0	Peripheral Qualifier				Peripheral Device Type				
1	Page Code (83h)								
2	Reserved (00h)								
3	Additional Page Length (20h)								
Node Name Identifier									
4	Protocol Identifier (0)				Code Set (1)				
5	PIV (1)	Rsvd	Association (0)		Identifier Type (3)				
6	Reserved								
7	Identifier Length (08h)								
8 to 15	(MSB)				Identifier				(LSB)
Port Name Identifier									
16	Protocol Identifier (0)				Code Set (1)				
17	PIV (1)	Rsvd	Association (1)		Identifier Type (3)				
18	Reserved								
19	Identifier Length (08h)								
20 to 27	(MSB)				Identifier				(LSB)
Port Number Identifier									
28	Protocol Identifier (0)				Code Set (1)				
29	PIV (1)	Rsvd	Association (1)		Identifier Type (4)				
30	Reserved								
31	Identifier Length (04h)								
32 to 35					(MSB) Identifier				(LSB)

Device Identification Page Definitions:

Peripheral Qualifier	The library returns a value of 000b indicating the specified peripheral device type is currently connected to this logical unit. If the command is sent to an unsupported logical unit, the value returned is 011b. (Note: xxxb indicates binary notation).
Peripheral Device Type	The library returns a value of 8h, which indicates that the library is a medium changer device. If the command is sent to an unsupported logical unit, the value returned is 1Fh.
Protocol Identifier	The library sets the Protocol Identifier field to 0h (Fibre)
Code Set	The library returns a value of 1, indicating the identifier contains binary values.
Identifier Type	<ul style="list-style-type: none"> ■ 3 = The identifier field contains a 64-bit IEEE formatted address ■ 4 = The identifier field contains a 4-byte port number
Identifier Length	<ul style="list-style-type: none"> ■ 04h = The identifier field is 4-bytes long ■ 08h = The identifier field is 8-bytes long
Identifier	Contains a binary value of the identifier
PIV	The library returns a value of 1, indicating the identifier type is valid
Association	<ul style="list-style-type: none"> ■ 0 = Identifier field is associated with the addressed logical unit ■ 1 = Identifier field is associated with the port that received the request

The 36-bytes of the device identification page indicates the vendor-specific portion of the Institute of Electrical and Electronics Engineers (IEEE) registered 64-bit ID for a Fibre Channel library.

The vendor-specific portion of the ID includes the library's Port name, Node name, and N_Port ID. This information is unique for each Fibre Channel interface card in the library.

The remaining 28 bits of the library's ID consist of:

- Name Address Authority (5h)
- Sun StorageTek company ID (00104Fh)

TABLE 6-13 shows the 64-bit IEEE-registered format that includes the Name Address Authority (NAA), company ID, and vendor-specific identifier.

TABLE 6-13 Fibre Channel Device Identification

(MSB = 63)		Bits	(LSB = 00)
NAA	IEEE Company ID	Vendor Specific Identifier	
5h	00 10 4F (h)	(Different for every FC card)	

Note – Every device on the loop must have a unique ID for login validation.

Log Sense

The Log Sense command (4Dh) enables the library to report its error logs and statistics to the initiator.

TABLE 6-14 Log Sense Command

Byte	Bit							
	7	6	5	4	3	2	1	0
0	Operation Code (4Dh)							
1	Ignored			Reserved (0)			PPC (0)	SP (0)
2	PC		Page Code					
3	Reserved (00h)							
4	Reserved (00h)							
5 to 6	(MSB)		Parameter Pointer				(LSB)	
7 to 8	(MSB)		Allocation Length				(LSB)	
9	Control Byte (00h)							

Log Sense Command Definitions:

PPC	Parameter Pointer Control is not supported (0).
SP	Save Parameters feature is not supported (0).
PC	The library accepts values of 0 or 1 in the Page Control field.
Page Code	<ul style="list-style-type: none"> ■ 00h = List Supported pages ■ 07h = List Last <i>n</i> Error Events page ■ 2Eh = Informational Exceptions TapeAlert page (0 or 1 in the PC field)
Parameter Pointer	The Parameter Pointer allows an initiator to request data starting at a specific parameter code. This value is set to 00h for page code 0h.
Allocation Length	<p>Specifies the number of bytes the initiator has allocated for data returned from the Log Sense command.</p> <p>A value of 0 is considered an error.</p> <p>The maximum data length for the log sense data that the library can return is 3C4h bytes.</p> <p>The length varies based on the Page Code selected.</p> <ul style="list-style-type: none"> ■ 00h = List Supported pages; length is 7h ■ 07h = List Last <i>n</i> Error Events page; length is 3C4h ■ 2Eh = Informational Exceptions TapeAlert page; length is 144h

Supported Pages Format page

The Supported Pages Format page lists all the Log Sense page codes supported by the library.

TABLE 6-15 Supported Pages Format Page

Byte	Bit								
	7	6	5	4	3	2	1	0	
0	Page Code (00h)								
1	Reserved (00h)								
2 to 3	(MSB)	Page Length ($n - 3$)						(LSB)	
4	Supported Pages Page Code (00h)								
5	Last n Errors Events Page Code (07h)								
6	Informational Exceptions TapeAlert Page Code (2Eh)								

Last n Errors Events Page Format

The Last n Errors Events Page provides a list of the most recent errors events logged on the library. Each event is an ASCII string that includes a time stamp, a fault symptom code (FSC), and an optional mechanism.

Note – Each error event is 48 bytes long, and can contain up to 20 events.

TABLE 6-16 Last n Errors Events Page

Byte	Bit							
	7	6	5	4	3	2	1	0
0	Page Code (07h)							
1	Reserved (00h)							
2 to 3	(MSB) Page Length ($n - 3$)							(LSB)
ASCII String for Event Specified by Parameter Pointer:								
4 to 7	Result Code							
8 to 11	Activity Code							
12 to 15	Request Id							
16 to 19	Op State							
20 to 23	Module							
24 to 27	Row							
28 to 31	Column							
32 to 33	Month							
34 to 35	Day							
36 to -37	Hour							
38 to 39	Minute							
40 to 42	Second							
43 to 51	Pad (ASCII spaces)							
Additional Events (48d bytes per event)								
n to 47 to n	Additional Log Parameters							

Note – Time is specified as universal time.

Informational Exceptions TapeAlert Page

The Informational Exceptions TapeAlert page is read from the library at a minimum of:

- At the beginning of a write/read job occurring on a device inside the library, even if media is not loaded in that device.
- Immediately after a fatal error during a write/read job occurring on a device inside the library.
- At the end of a write/read job occurring on a device inside the library.

Though not mandatory, the host software may also poll the Log Sense page every 60 seconds while the tape library is idle.

Each flag will be cleared to zero in the following circumstances:

- At library power on.
- When the TapeAlert Log page is read.
- On a reset.

TABLE 6-17 lists information about the Informational Exceptions TapeAlert Page format. The TapeAlert page returns A4h bytes in this format.

The *n* represents a TapeAlert flag; currently, all values are set to default. Unsupported flags are also returned as defaults.

TABLE 6-17 Informational Exceptions TapeAlert Page Format

Byte	Bit								
	7	6	5	4	3	2	1	0	
0	Page Code (2Eh)								
1	Reserved (00h)								
2 to 3	(MSB)		Page Length (<i>5n</i>)						(LSB)
TapeAlert Flags: <i>n</i> goes from 1 to 32									
<i>5n - 1</i> to <i>5n</i>	Parameter Code (<i>n</i>)								
<i>5n + 1</i>	DU (0)	DS (1)	TSD (0)	ETC (0)	TMC (0)	Rsvd (0)	LBIN (0)	LP (0)	
<i>5n + 2</i>	Parameter Length								
<i>5n + 3</i>	Value of Flag							Flag	

Note – The entire TapeAlert page should be read to obtain all the information.

Informational Exceptions TapeAlert Page Definitions:

Parameter Code	A 2-byte field which represents the TapeAlert Flag number.
DU	Disable Update is always 0, which indicates that the target updates the log parameter value instead of the initiator.
DS	Disable Save is always 1, which indicates saving the log is not supported.
TSD	Target Save Disable is always 0.
ETC	Enable Threshold Comparison is always 0.
TMC	Threshold Met Criteria is always 0.
LBIN	The library returns 0 indicating it is not used.
LP	List Parameter is always 0, which indicates the log parameter is a data counter.
Parameter Length	Parameter Length is always 0x01. All are 1-byte flags.
Flag	A value of 0x01 indicates that the flag the Parameter Code is pointed to is active; all other values are off.

TapeAlert Flags

TABLE 6-18 lists information about the TapeAlert flags. Flags are:

- in sequential order,
- have valid values of 0 (off) or 1 (on)
- reports all 32

Type codes indicate:

- C = Critical,
- W = Warning,
- I = Informational.

TABLE 6-18 TapeAlert Flags

Code	Flag Name	Description	Type
0001h	Library Hardware A	Set when the library cannot communicate with a tape drive. This does <i>not</i> cause the library to stop operating.	C
0002h	Library Hardware B	Set when the servo control mechanism breaks lock. The various causes are when the hand positioning on the column fails or when the hand fails.	W
0003h	Library Hardware C	Set when the library has a hardware fault.	C
0004h	Library Hardware D	Set when camera initialization, calibration, or mechanical initialization test fails.	C
0005h	Library Diagnostics Required	Set when the library might have a hardware fault.	W
0006h	Library Interface	Set when a corrupted SCSI command is sent to the library from an initiator. Currently, this flag is set when a parity error is detected on the SCSI bus.	C
0007h	Predictive Failure	Set when a library hardware failure is predicted.	W
0008h	Library Maintenance	Set when preventive maintenance is required.	W

TABLE 6-18 TapeAlert Flags (Continued)

0009h	Library Humidity Limits	Set when general conditions inside the library exceed the humidity specifications.	C
000Ah	Library Temperature Limits	Set when general conditions inside the library exceed the temperature specifications.	C
000Bh	Library Voltage Limits	Set when the voltage supply exceeds specifications.	C
000Ch	Library Stray Tape	Set when a cartridge was left in a drive because of a previous hardware fault.	C
000Dh	Library Pick Retry	Set if the hand requires more than one try to pick a cartridge from a cell or drive.	W
000Eh	Library Place Retry	Set if the hand requires more than one try to place a cartridge into a cell.	W
000Fh	Library Load Retry	Set if the hand requires more than one try to place a cartridge into a drive.	W
0010h	Library Door	Set if the door has been opened, and no library motions are allowed. When the door is closed, the library will IPL.	C
0011h	Library Mail slot	Set when the mail slot (cartridge access port) switch has failed.	C
0012h	Library Magazine	Set when the library needs the magazine.	C
0013h	Library Security	Set when the security was compromised.	W
0014h	Library Security Mode	Set when the security mode was changed.	I
0015h	Library Offline	Set when the library has been placed into maintenance mode from the operator panel or a Web interface.	I
0016h	Library Drive Offline	Set when a drive was taken offline.	I
0017h	Library Scan Retry	Set when more than one attempt is required to read a bar code. The problem is caused when only part of the bar code can be read. The library supports cartridges with no labels.	W
0018h	Library Inventory	Set when the library detected an inconsistency in its inventory.	C
0019h	Library Illegal Operation	Set when an unsupported SCSI command is sent to the library. This is <i>not</i> a corrupted command detected for flag 6.	W
001Bh	Cooling Fan failure	Set when the library cooling fan has failed	W
001Ch	Power Supply	Set when a redundant power supply has failed inside the library. Check the library users manual for instructions on replacing the failed power supply.	W
001Dh	Power Consumption	Set when the library power consumption is outside the specified range.	W
0020h	Unreadable Bar Code Labels	The library was unable to read the bar code on a cartridge.	I

Mode Select (6)

The 6-byte Mode Select command (15h) enables an initiator to specify certain operating parameters for the library. The library uses the saved or default versions of these parameters to configure itself during power-on or after a logical unit reset.

The mode values sent to the library apply to all initiators. If an initiator issues a Mode Select command that changes any parameters, the library generates a Check Condition status to all other initiators with a sense key of Unit Attention and an Additional Sense Code (ASC) and Additional Sense Code Qualifier (ASCQ) of Mode Parameters Changed.

When the library receives a Mode Select (6) command, the library validates all parameters before it performs any changes. If a value is not valid, the library returns the appropriate error message and does not change the parameters.

TABLE 6-19 Mode Select (6) Command

Byte	Bit							
	7	6	5	4	3	2	1	0
0	Operation Code (15h)							
1	Ignored			PF (1)	Reserved (0)			SP
2	Reserved (00h)							
3	Reserved (00h)							
4	Parameter List Length							
5	Control Byte							

Mode Select (6) Command Definitions:

PF	Page Format supports SCSI-3 specification and requires a value of 1.
SP	The library supports the saved page (SP) function. The values are: 0 = Current mode values are changed to the values specified by this command. Saved values are not affected. 1 = Current mode values and saved mode values are changed to the values specified by this command.
Parameter List Length	00h = No data transferred Note: A value of 00h is not considered an error. Any other value is considered an error and is not supported. <ul style="list-style-type: none"> ■ 10h = Mode Parameter Header and Informational Exceptions TapeAlert Mode Page are transferred ■ 18h = Mode Parameter Header and Element Address Assignment Page are transferred ■ 0Ch = Mode Parameter Header and Logical Unit Page are transferred ■ 0Ch = Mode Parameter Header and Port Control Page are transferred

Mode Select (6) Data

The initiator must provide mode parameter data in a parameter list including:

- “Mode Select (6) Parameter Header” on page 106
- “Fibre Channel Logical Unit Page” on page 107
- “Low Voltage Differential SCSI Logical Unit Page” on page 108
- “Fibre Channel Port Control Page” on page 109
- “Low Voltage Differential SCSI Port Control Page” on page 110
- “Informational Exceptions TapeAlert Page” on page 111 or
- “Element Address Assignment Mode Page” on page 113

If the parameter list length field in the command is 0, then no Mode Select data is required.

Note – Before issuing any Mode Select commands, an initiator should issue a Mode Sense command with the Page Control field set to 01h, and the Page Code field set to 3Fh to determine which pages are supported, which parameters within the pages are changeable, and the supported length of each page.

Mode Select (6) Parameter Header

The library returns a four-byte Mode Select parameter header as follows:

TABLE 6-20 Mode Select Parameter (6) Header

Byte	Bit							
	7	6	5	4	3	2	1	0
0	Reserved (00h)							
1	Reserved (00h)							
2	Reserved (00h)							
3	Reserved (00h)							

Note – The header definitions for the library must all be 00h.

Fibre Channel Logical Unit Page

The following table shows the format of the Fibre Channel Logical Unit page.

TABLE 6-21 Fibre Channel Logical Unit Page

Byte	Bit							
	7	6	5	4	3	2	1	0
0	PS (0)	SPF (0)	Page Code (18h)					
1	Page Length (06h)							
2	Reserved				Protocol Identifier (0)			
3	Reserved							EPDC (0)
4 to 7	(MSB)	Reserved						(LSB)

Fibre Channel Logical Unit Page Definitions:

PS	The Parameters Saveable bit is set to 0.
SPF	The library returns a value of 0 for the SubPage Format bit, indicating page_0 format is being used.
Protocol Identifier	This field is set to 0h indicating the Fibre Channel protocol.
EPDC	Enable Precise Delivery Checking bit is set to 0 (not supported)

Low Voltage Differential SCSI Logical Unit Page

The following table shows the format of the SCSI (LVD) Logical Unit Page.

TABLE 6-22 SCSI (LVD) Logical Unit Page

Byte	Bit							
	7	6	5	4	3	2	1	0
0	PS (0)	SPF (0)	Page Code (18h)					
1	Page Length (06h)							
2	Reserved				Protocol Identifier (1h)			
3 to 7	(MSB) Reserved							(LSB)

SCSI (LVD) Logical Unit Page Definitions:

PS	The Parameters Saveable bit is set to 0.
SPF	The library returns a value of 0 for the SubPage Format bit, indicating page_0 format is being used.
Protocol Identifier	The field is set to 1h indicating the Parallel SCSI protocol.

Fibre Channel Port Control Page

The following table shows the format of the Fibre Channel Port Control page.

TABLE 6-23 Fibre Channel Port Control Page

Byte	Bit							
	7	6	5	4	3	2	1	0
0	PS (0)	Rsvd	Page Code (19h)					
1	Page Length (06h)							
2	Reserved				Protocol Identifier (0)			
3	DTFD	PLPB	DDIS	DLM	DSA	ALWI	DTIPE	DTOLI
4	Reserved							
5	Reserved							
6	Reserved					RR_TOV units		
7	Resource Recovery Time Out Value (RR_TOV)							

Fibre Channel Port Control Page Definitions:

PS	The Parameters Saveable bit is set to 0.
Protocol Identifier	This field is set to 0h indicating the Fibre Channel protocol.
DTFD	Disable Target Fabric Discovery <ul style="list-style-type: none"> ■ 0 = Public Loop behavior supported ■ 1 = Private Loop only supported
PLPB	Prevent Loop Port Bypass is set to 0
DDIS	Disable Discovery is set to 0
DLM	Disable Loop Master is set to 0
DSA	Disable Soft Address is set to 0
ALWI	Allow Login Without Loop Initialization is set to 0
DTIPE	Disable Target Initiated Port Enable is set to 0
DTOLI	Disable Target Originated Loop Initialization is set to 0
RR_TOV units	Resource Recovery Time Out Value Units will always be 100b = 10 second units
RR_TOV	Resource Recovery Time Out Value will always be 1Eh = 300 seconds

Low Voltage Differential SCSI Port Control Page

The following table shows the format of the SCSI (LVD) Port Control page.

TABLE 6-24 SCSI (LVD) Port Control Page

Byte	Bit							
	7	6	5	4	3	2	1	0
0	PS (0)	SPF (0)	Page Code (19h)					
1	Page Length (06h)							
2	Reserved				Protocol Identifier (1h)			
3	Reserved							
4 to 5	(MSB) Synchronous Transfer Timeout							(LSB)
6	Reserved							
7	Reserved							

SCSI (LVD) Port Control Page Definitions:

PS	The Parameters Saveable bit is set to 0.
SPF	The library returns a value of 0 for the SubPage Format bit, indicating page_0 format is being used.
Protocol Identifier	The field is set to 1h indicating the Parallel SCSI protocol.
Synchronous Transfer Timeout	<p>Indicates the maximum amount of time in 1 ms increments that SCSI target port shall wait before generating an error by doing an unexpected bus free. The SCSI target port shall only go to a BUS FREE phase if one of the following events cause the timer, once started, to not reset or reload before expiring.</p> <ul style="list-style-type: none"> ■ If there is a REQ transition when there are no outstanding REQs waiting for an ACK then load and start the timer. ■ If there is a REQ transition when there are any outstanding REQs waiting for an ACK then there is no effect on the timer. ■ If there is an ACK transition when there are outstanding REQs waiting for an ACK then load and start the timer. ■ If after an ACK transition there are no outstanding REQs waiting for an ACK then stop the timer. <p>A Synchronous Transfer Timeout field value of 0000h indicates that the function is disabled. A value of FFFFh indicates an unlimited period.</p>

Informational Exceptions TapeAlert Page

TABLE 6-25 defines the Informational Exceptions TapeAlert page.

TABLE 6-25 Informational Exceptions TapeAlert Page

Byte	Bit							
	7	6	5	4	3	2	1	0
0	PS (0)	SPF (0)	Page Code (1Ch)					
1	Page Length (0Ah)							
2	Perf (0)	Rsvd (0)	EBF(0)	EWasc	DExcpt (1)	Test	Rsvd (0)	LogErr (0)
3	Reserved (0)				MRIE (3h)			
4 to 7	(MSB) Interval Timer							(LSB)
8 to 11	(MSB) Report Counter / Test Flag Number							(LSB)

Informational Exceptions TapeAlert Definitions:

PS	The Parameters Saveable bit is set to 0.
SPF	The library accepts a value of 0 for the SubPage Format bit, indicating page_0 format is being used.
Perf	Performance bit is set to 0, which indicates acceptance of informational exception operations that cause delays.
EBF	Enable Background Functions bit will always be 0.
EWasc	This should be set to 0 for the enable warning bit, indicating warning reporting shall be disabled.
DExcpt	The library accepts a value of 1, which indicates the target Disables All Information Exception operations and <i>ignores</i> the MRIE field. In this mode, the software must poll the TapeAlert Log page.
Test	<ul style="list-style-type: none"> ■ 0 = The library does not generate false/test informational exceptions. ■ 1 = The library generates false/test informational exception conditions.
LogErr	The Log Error information exception conditions is set to 0, which indicates this is vendor-specific.
MRIE	Method the library uses to Report Informational Exceptions must be 3h, which indicates that the library reports any informational exception conditions by returning Check Condition status.
Interval Timer	Bytes 4 through 7 must be 00h. The library will only report informational exception condition one time.
Report Counter / Test Flag Number	<p>This is a dual purpose field:</p> <ul style="list-style-type: none"> ■ When the Test Flag bit is 0, this field is the report counter. Bytes 8 through 11 must be set to 00h to indicate there is no limit to the number of times the library will report the informational exception condition. This value is returned with Mode Sense. ■ When the Test bit is 1, this field is the test flag number.

Test Modes

Two test mode options are supported in the current TapeAlert implementation.

Test Mode for All Bits Supported

Using the mode select command to initiate this test will set all of the flags supported by the TapeAlert implementation in the TapeAlert log page. The TapeAlert log sense page then can be read to give the host a snapshot of the supported flags.

The flags will be cleared when the page is read. To do this, set the test mode flag in the TapeAlert mode select page. This indicates that the Report Count/Test Flag Number field is in Test Flag Number mode. Next, set the test flag number to 0x7FFF and issue the Mode Select command. When the command is complete, the TapeAlert log sense page can be read.

Test Mode for Individual Bits

Another test mode allows individual bits to be turned on. This can be useful for the host to debug/test operator interfaces.

Any flag set must be a supported flag. If the flag is not supported, a check condition with an incorrect parameter code is returned. The TapeAlert log sense page then can be read to allow the host to get a log page with the flag of interest set. The flag will be cleared when the page is read.

To test a flag, set the Test Flag in the TapeAlert mode select page. This indicates the Report Count/Test Flag Number field is in Test Flag mode. Set the number of the flag to be tested. Issue the Mode Select command. When the command is complete, the TapeAlert log sense page can be read.

Element Address Assignment Mode Page

This table defines the Element Address Assignment Mode page.

TABLE 6-26 Mode Select (6) Element Address Assignment Mode Page

Byte	Bit							
	7	6	5	4	3	2	1	0
0	PS (0)	Rsvd (0)	Page Code (1Dh)					
1	Parameter Length (12h)							
2 to 3	(MSB)	First Medium Transport Element Address						(LSB)
4 to 5	(MSB)	Number of Medium Transport Elements (0001h)						(LSB)
6 to 7	(MSB)	First Storage Element Address						(LSB)
8 to 9	(MSB)	Number of Storage Elements						(LSB)
10 to 11	(MSB)	First Import/Export Element Address						(LSB)
12 to 13	(MSB)	Number of Import/Export Elements						(LSB)
14 to 15	(MSB)	First Data Transfer Element Address						(LSB)
16 to 17	(MSB)	Number of Data Transfer Elements						(LSB)
18	Reserved (00h)							
19	Reserved (00h)							

Mode Select (6) Element Address Assignment Mode Page Definitions:

PS	The Parameters Saveable bit is set to 0.
Page Code	Identifies the Element Address Assignment mode page.
Parameter Length	Indicates the length of the element address assignment parameter list. This field must be 12h, which indicates that there are an additional 12h (18d) bytes of parameter data following this byte.
First Medium Transport Element Address	Identifies the address of the hand in the library. The library has only one hand, so the default value is 0000h.
Number of Medium Transport Elements	Identifies the number of hands in the library. The library has only one hand, so this field must be 0001h (1d).
First Storage Element Address	Identifies the starting address of the cartridge tape storage cells in the library, and the default starting address is 03E8h (1000d).
Number of Storage Elements	Identifies the number of cartridge tape storage cells in the library. This number is based on the configuration of the library and is obtained when the library performs a Mode Sense of mode page 1Dh. The number in the Mode Select command must be the same number returned by the Mode Sense command.
First Import/Export Element Address	Identifies the address of the first Import/Export element. This address is the first CAP element 000Ah (10d) or the first PTP element 0008h(8d).
Number of Import/Export Elements	Identifies the number of Import/Export storage locations. This value is obtained when the library performs a Mode Sense of mode page 1Dh. The number in the Mode Select command must be the same number returned by the Mode Sense command.
First Data Transfer Element Address	Identifies the address of the first tape drive; the default setting address is 1F4h (500d).
Number of Data Transfer Elements	Identifies the total number of tape drives installed in the library. This number varies depending on the configuration. Obtain this value by requesting a Mode Sense of mode page 1Dh. The number in the Mode Select command must be the same number returned by the Mode Sense command.

Element Address Assignments

An initiator can modify the element addresses in the library using a Mode Select command. The four element types are:

- Medium transport (the hand)
- Storage element (storage cells)
- Import/export (cartridge access port and Pass-thru Port)
- Data transfer (tape drives)

Each element type is defined as a range of consecutive elements based on a starting element and a count. The ranges may be configured in any order, but one element type range may not overlap another element type range, and gaps between ranges are allowed.

To change the element address assignments, an initiator should first perform a Mode Sense of mode page 1Dh (Element Address Assignment Page). This provides the count of each element type. The count of each element type cannot be changed and must be used as obtained from the Mode Sense command. Only the starting element number can be modified. The initiator must calculate the starting addresses of each type to ensure no overlaps.

Because the library supports the saved page function, the element address assignments can be saved in non-volatile memory. These values are used to configure the library:

- During power-on
- After a logical unit reset

Mode Select (10)

The 10-byte Mode Select command (55h) enables an initiator to specify certain operating parameters for the library. The library uses the saved or default versions of these parameters to configure itself during power-on or after a logical unit reset.

The mode values sent to the library apply to all initiators. If an initiator issues a Mode Select command that changes any parameters, the library generates a Check Condition status to all other initiators with a sense key of Unit Attention and an Additional Sense Code (ASC) and Additional Sense Code Qualifier (ASCQ) of Mode Parameters Changed.

When the library receives a Mode Select (10) command, the library validates all parameters before it performs any changes. If a value is not valid, the library returns the appropriate error message and does not change the parameters.

TABLE 6-27 Mode Select (10) Command

Byte	Bit							
	7	6	5	4	3	2	1	0
0	Operation Code (55h)							
1	Ignored			PF (1)	Reserved (0)			SP
2	Reserved (00h)							
3	Reserved (00h)							
4	Reserved (00h)							
5	Reserved (00h)							
6	Reserved (00h)							
7 to 8	(MSB)	Parameter List Length						(LSB)
9	Reserved (00h)							

Mode Select (10) Command Definitions:

PF	Page Format supports SCSI-3 specification and requires a value of 1.
SP	The library supports the saved page (SP) function. The values are: <ul style="list-style-type: none"> ■ 0 = Current mode values are changed to the values specified by this command. Saved values are not affected. ■ 1 = Current mode values and saved mode values are changed to the values specified by this command.

Parameter List Length	<ul style="list-style-type: none"> ■ 00h = No data transferred A value of 00h is not considered an error. Any other value is considered an error and is not supported. ■ 14h = Mode Parameter Header and Informational Exceptions TapeAlert Mode Page are transferred ■ 1Ch = Mode Parameter Header and Element Address Assignment Page are transferred ■ 10h = Mode Parameter Header and Logical Unit Page are transferred ■ 10h = Mode Parameter Header and Port Control Page are transferred
------------------------------	--

Mode Select (10) Data

The initiator must provide mode parameter data in a parameter list including:

- [“Mode Select \(10\) Parameter Header” on page 117](#)
- [“Fibre Channel Logical Unit Page” on page 118](#)
- [“Low Voltage Differential SCSI Logical Unit Page” on page 119](#)
- [“Fibre Channel Port Control Page” on page 120](#)
- [“Low Voltage Differential SCSI Port Control Page” on page 121](#)
- [“Informational Exceptions TapeAlert Page” on page 122](#) or
- [“Element Address Assignment Mode Page” on page 124](#)

Mode Select (10) Parameter Header

The library returns a 8-byte Mode Select parameter header as follows:

TABLE 6-28 Mode Select Parameter Header

Byte	Bit							
	7	6	5	4	3	2	1	0
0	Reserved (00h)							
1	Reserved (00h)							
2	Reserved (00h)							
3	Reserved (00h)							
4	Reserved (00h)							
5	Reserved (00h)							
6	Reserved (00h)							
7	Reserved (00h)							

Note – The header definitions for the library must be all 00h.

Fibre Channel Logical Unit Page

The following table shows the format of the Fibre Channel Logical Unit page.

TABLE 6-29 Fibre Channel Logical Unit Page

Byte	Bit							
	7	6	5	4	3	2	1	0
0	PS (0)	SPF (0)	Page Code (18h)					
1	Page Length (06h)							
2	Reserved				Protocol Identifier (0)			
3	Reserved							EPDC (0)
4 to 7	(MSB)	Reserved						(LSB)

Fibre Channel Logical Unit Page Definitions:

PS	The Parameters Saveable bit is set to 0.
SPF	The library returns a value of 0 for the SubPage Format bit, indicating page_0 format is being used.
Protocol Identifier	This field is set to 0h indicating the Fibre Channel protocol.
EPDC	Enable Precise Delivery Checking bit is set to 0 (not supported)

Low Voltage Differential SCSI Logical Unit Page

The following table shows the format of the SCSI (LVD) Logical Unit Page.

TABLE 6-30 SCSI (LVD) Logical Unit Page

Byte	Bit							
	7	6	5	4	3	2	1	0
0	PS (0)	SPF (0)	Page Code (18h)					
1	Page Length (06h)							
2	Reserved				Protocol Identifier (1h)			
3 to 7	(MSB)	Reserved						(LSB)

SCSI (LVD) Logical Unit Page Definitions:

PS	The Parameters Saveable bit is set to 0.
SPF	The library returns a value of 0 for the SubPage Format bit, indicating page_0 format is being used.
Protocol Identifier	The field is set to 1h indicating the Parallel SCSI protocol.

Fibre Channel Port Control Page

The following table shows the format of the Fibre Channel Port Control page.

TABLE 6-31 Fibre Channel Port Control Page

Byte	Bit								
	7	6	5	4	3	2	1	0	
0	PS (0)	Rsvd	Page Code (19h)						
1	Page Length (06h)								
2	Reserved				Protocol Identifier (0)				
3	DTFD	PLPB	DDIS	DLM	DSA	ALWI	DTIPE	DTOLI	
4	Reserved								
5	Reserved								
6	Reserved					RR_TOV units			
7	Resource Recovery Time Out Value (RR_TOV)								

Fibre Channel Port Control Page Definitions:

PS	The Parameters Saveable bit is set to 0.
Protocol Identifier	This field is set to 0h indicating the Fibre Channel protocol.
DTFD	Disable Target Fabric Discovery ■ 0 = Public Loop behavior supported ■ 1 = Private Loop only supported
PLPB	Prevent Loop Port Bypass is set to 0
DDIS	Disable Discovery is set to 0
DLM	Disable Loop Master is set to 0
DSA	Disable Soft Address is set to 0
ALWI	Allow Login Without Loop Initialization is set to 0
DTIPE	Disable Target Initiated Port Enable is set to 0
DTOLI	Disable Target Originated Loop Initialization is set to 0
RR_TOV units	Resource Recovery Time Out Value Units will always be 100b = 10 second units
RR_TOV	Resource Recovery Time Out Value will always be 1Eh = 300 seconds

Low Voltage Differential SCSI Port Control Page

The following table shows the format of the SCSI (LVD) Port Control page.

TABLE 6-32 SCSI (LVD) Port Control Page

Byte	Bit							
	7	6	5	4	3	2	1	0
0	PS (0)	SPF (0)	Page Code (19h)					
1	Page Length (06h)							
2	Reserved				Protocol Identifier (1h)			
3	Reserved							
4 to 5	(MSB) Synchronous Transfer Timeout							(LSB)
6	Reserved							
7	Reserved							

SCSI (LVD) Port Control Page Definitions:

PS	The Parameters Saveable bit is set to 0.
SPF	The library returns a value of 0 for the SubPage Format bit, indicating page_0 format is being used.
Protocol Identifier	The field is set to 1h indicating the Parallel SCSI protocol.
Synchronous Transfer Timeout	<p>Indicates the maximum amount of time in 1 ms increments that SCSI target port shall wait before generating an error by doing an unexpected bus free. The SCSI target port shall only go to a BUS FREE phase if one of the following events cause the timer, once started, to not reset or reload before expiring.</p> <ul style="list-style-type: none"> ■ If there is a REQ transition when there are no outstanding REQS waiting for an ACK then load and start the timer. ■ If there is a REQ transition when there are any outstanding REQS waiting for an ACK then there is no effect on the timer. ■ If there is an ACK transition when there are outstanding REQS waiting for an ACK then load and start the timer. ■ If after an ACK transition there are no outstanding REQS waiting for an ACK then stop the timer. <p>A Synchronous Transfer Timeout field value of 0000h indicates that the function is disabled. A value of FFFFh indicates an unlimited period.</p>

Informational Exceptions TapeAlert Page

The following table defines the Informational Exceptions TapeAlert page.

TABLE 6-33 Informational Exceptions TapeAlert Page

Byte	Bit							
	7	6	5	4	3	2	1	0
0	PS (0)	SPF (0)	Page Code (1Ch)					
1	Page Length (0Ah)							
2	Perf (0)	Rsvd (0)	EBF(0)	EWasc	DExcpt (1)	Test	Rsvd (0)	LogErr (0)
3	Reserved (0)				MRIE (3h)			
4 to 7	(MSB) Interval Timer							(LSB)
8 to 11	(MSB) Report Counter / Test Flag Number							(LSB)

Informational Exceptions TapeAlert Definitions:

PS	The Parameters Saveable bit is set to 0.
SPF	The library accepts a value of 0 for the SubPage Format bit, indicating page_0 format is being used.
Perf	Performance bit is set to 0, which indicates acceptance of informational exception operations that cause delays.
EBF	Enable Background Functions bit will always be 0.
EWasc	This should be set to 0 for the enable warning bit, indicating warning reporting shall be disabled.
DExcpt	The library accepts a value of 1, which indicates the target Disables All Information Exception operations and <i>ignores</i> the MRIE field. In this mode, the software must poll the TapeAlert Log page.
Test	<ul style="list-style-type: none"> ■ 0 = The library does not generate false/test informational exceptions. ■ 1 = The library generates false/test informational exception conditions.
LogErr	The Log Error information exception conditions is set to 0, which indicates this is vendor-specific.
MRIE	Method the library uses to Report Informational Exceptions must be 3h, which indicates that the library reports any informational exception conditions by returning Check Condition status.
Interval Timer	Bytes 4 through 7 must be 00h. The library will only report informational exception condition one time.
Report Counter / Test Flag Number	<p>This is a dual purpose field:</p> <ul style="list-style-type: none"> ■ When the Test Flag bit is 0, this field is the report counter. Bytes 8 through 11 must be set to 00h to indicate there is no limit to the number of times the library will report the informational exception condition. This value is returned with Mode Sense. ■ When the Test bit is 1, this field is the test flag number.

Test Modes

Two test mode options are supported in the current TapeAlert implementation.

Test Mode for All Bits Supported

Using the mode select command to initiate this test will set all of the flags supported by the TapeAlert implementation in the TapeAlert log page. The TapeAlert log sense page then can be read to give the host a snapshot of the supported flags.

The flags will be cleared when the page is read. To do this, set the test mode flag in the TapeAlert mode select page. This indicates that the Report Count/Test Flag Number field is in Test Flag Number mode. Next, set the test flag number to 0x7FFF and issue the Mode Select command. When the command is complete, the TapeAlert log sense page can be read.

Test Mode for Individual Bits

Another test mode allows individual bits to be turned on. This can be useful for the host to debug/test operator interfaces.

Any flag set must be a supported flag. If the flag is not supported, a check condition with an incorrect parameter code is returned. The TapeAlert log sense page then can be read to allow the host to get a log page with the flag of interest set. The flag will be cleared when the page is read.

To test a flag, set the Test Flag in the TapeAlert mode select page. This indicates the Report Count/Test Flag Number field is in Test Flag mode. Set the number of the flag to be tested. Issue the Mode Select command. When the command is complete, the TapeAlert log sense page can be read.

Element Address Assignment Mode Page

This table defines the Element Address Assignment Mode page.

TABLE 6-34 Mode Select (6) Element Address Assignment Mode Page

Byte	Bit								
	7	6	5	4	3	2	1	0	
0	PS (0)	Rsvd (0)	Page Code (1Dh)						
1	Parameter Length (12h)								
2 to 3	(MSB)	First Medium Transport Element Address						(LSB)	
4 to 5	(MSB)	Number of Medium Transport Elements (0001h)						(LSB)	
6 to 7	(MSB)	First Storage Element Address						(LSB)	
8 to 9	(MSB)	Number of Storage Elements						(LSB)	
10 to 11	(MSB)	First Import/Export Element Address						(LSB)	
12 to 13	(MSB)	Number of Import/Export Elements						(LSB)	
14 to 15	(MSB)	First Data Transfer Element Address						(LSB)	
16 to 17	(MSB)	Number of Data Transfer Elements						(LSB)	
18	Reserved (00h)								
19	Reserved (00h)								

Mode Select (6) Element Address Assignment Mode Page Definitions:

PS	The Parameters Saveable bit is set to 0.
Page Code	Identifies the Element Address Assignment mode page.
Parameter Length	Indicates the length of the element address assignment parameter list. This field must be 12h, which indicates that there are an additional 12h (18d) bytes of parameter data following this byte.
First Medium Transport Element Address	Identifies the address of the hand in the library. The library has only one hand, so the default value is 0000h.
Number of Medium Transport Elements	Identifies the number of hands in the library. The library has only one hand, so this field must be 0001h (1d).
First Storage Element Address	Identifies the starting address of the cartridge tape storage cells in the library, and the default starting address is 03E8h (1000d).
Number of Storage Elements	Identifies the number of cartridge tape storage cells in the library. This number is based on the configuration of the library and is obtained when the library performs a Mode Sense of mode page 1Dh. The number in the Mode Select command must be the same number returned by the Mode Sense command.
First Import/Export Element Address	Identifies the address of the first Import/Export element. This address is the first CAP element 000Ah (10d) or the first PTP element 0008h(8d).
Number of Import/Export Elements	Identifies the number of Import/Export storage locations. This value is obtained when the library performs a Mode Sense of mode page 1Dh. The number in the Mode Select command must be the same number returned by the Mode Sense command.
First Data Transfer Element Address	Identifies the address of the first tape drive; the default setting address is 1F4h (500d).
Number of Data Transfer Elements	Identifies the total number of tape drives installed in the library. This number varies depending on the configuration. Obtain this value by requesting a Mode Sense of mode page 1Dh. The number in the Mode Select command must be the same number returned by the Mode Sense command.

Element Address Assignments

An initiator can modify the element addresses in the library using a Mode Select command. The four element types are:

- Medium transport (the hand)
- Storage element (storage cells)
- Import/export (cartridge access port and Pass-thru Port)
- Data transfer (tape drives)

Each element type is defined as a range of consecutive elements based on a starting element and a count. The ranges may be configured in any order, but one element type range may not overlap another element type range, and gaps between ranges are allowed.

To change the element address assignments, an initiator should first perform a Mode Sense of mode page 1Dh (Element Address Assignment Page). This provides the count of each element type. The count of each element type cannot be changed and must be used as obtained from the Mode Sense command. Only the starting element number can be modified. The initiator must calculate the starting addresses of each type to ensure no overlaps.

Because the library supports the saved page function, the element address assignments can be saved in non-volatile memory. These values are used to configure the library:

- During power-on
- After a logical unit reset

Mode Sense (6)

The 6-byte Mode Sense command (1Ah) enables the library to report its operating mode parameters to the initiator.

- The initiator can request one page or all pages of the mode parameters.
- The initiator can use the Mode Select command to change the values of certain mode parameters.
- Before issuing any Mode Select commands, an initiator should issue a Mode Sense command with the Page Control field set to 01h, and the Page Code field set to 3Fh to determine which:
 - Pages are supported
 - Parameters within the pages are changeable
 - Supported length of each page

TABLE 6-35 Mode Sense Command

Byte	Bit							
	7	6	5	4	3	2	1	0
0	Operation Code (1Ah)							
1	Ignored			Rsvd	DBD	Reserved (0)		
2	Page Control		Page Code					
3	SubPage Code (00h)							
4	Allocation Length							
5	Control Byte							

Mode Sense (6) Command Definitions:

DBD	Disable Block Descriptors is ignored.
Page Control	<p>Defines the type of parameters to be returned for the Mode Sense command, values include:</p> <hr/> <p>0h (00b) = Current Values: The library returns the current parameter values, including: Parameters set in the last successful Mode Select command. Default values if saved values are unavailable or invalid. Saved values if a MODE command has not been executed since the last power-on, interface reset, or Bus Device Reset.</p> <hr/> <p>1h (01b) = Changeable Values: The library returns the changeable parameter masks. All requested pages are returned Pages indicate which parameters are changeable by the initiator All bits of changeable parameters are set to 1 All bits of parameters that are not changeable are set to 0</p> <hr/> <p>2h (10b) = Default Values: The library returns the default values. Requested pages are returned with each supported parameter set to its default Parameters not supported by the library are set to 0. Default values for the Element Address Assignment page are based on the configuration of the library.</p> <hr/> <p>3h (11b) = Saved Values: The library returns the saved values. Requested pages are returned with supported parameters set to its saved value. Parameters not supported by the library are set to 0. This option is valid only with mode pages that can be saved.</p>
Page Code	<p>Specifies which pages the library returns, including:</p> <ul style="list-style-type: none"> ■ 18h = Protocol Specific Logical Unit page ■ 19h = Protocol Specific Port Control page ■ 1Ch = Informational Exceptions TapeAlert page ■ 1Dh = Element Address Assignment page ■ 1Eh = Transport Geometry page ■ 1Fh = Device Capabilities page ■ 3Fh = All pages (in the above order)
SubPage Code	Not supported
Allocation Length	<p>Specifies the length of the parameter list the library returns. The maximum length is 4Ch (76d) bytes. The length varies based on the Page Code selected:</p> <ul style="list-style-type: none"> ■ 4 bytes for the parameter list header (always present) ■ 8 additional bytes for the Protocol Specific Logical Unit Control page ■ 8 additional bytes for the Protocol Specific Port Control page ■ 12 additional bytes for the Informational Exceptions TapeAlert page ■ 20 additional bytes for the Element Address Assignment page ■ 4 additional bytes for the Transport Geometry page ■ 20 additional bytes for the Device Capabilities page <p>The library transfers the number of bytes specified by the Allocation Length or the available Mode Sense data, whichever is less.</p>

Mode Sense (6) Data

The library returns the following mode sense data:

- A four-byte Mode Parameter Header followed by
- One mode page or all mode pages in the order specified in the Page Code list.
The mode pages available are those defined for medium changers in the Fibre Channel standard, including:
 - “Fibre Channel Logical Unit Page” on page 130
 - “Low Voltage Differential SCSI Logical Unit Page” on page 131
 - “Fibre Channel Port Control Page” on page 132
 - “Low Voltage Differential SCSI Port Control Page” on page 133
 - “Informational Exceptions TapeAlert Control Page” on page 134
 - “Element Address Assignment Page Definition” on page 135
 - “Transport Geometry Mode Page Definition” on page 137
 - “Device Capabilities Page Definition” on page 138
 - Plus those defined for medium changers in the SCSI standard including a SCSI Logical Unit Control page and a SCSI Port Control page.
- The data can be truncated to the length specified in the allocation length field.

Mode Sense (6) Parameter Header Definition

The following table shows the Mode Sense Parameter Header page.

TABLE 6-36 Mode Sense (6) Parameter Header

Byte	Bit							
	7	6	5	4	3	2	1	0
0	Mode Data Length							
1	Reserved							
2	Reserved							
3	Block Descriptor Length (00h)							

Mode Sense (6) Parameter Header Page Definitions:

Mode Data Length	This field indicates the number of bytes of parameter information available to be transferred to the initiator, regardless of the allocation length. This field excludes the Mode Data Length byte but includes three additional Mode Parameter Header bytes and any mode pages that follow.
Block Descriptor Length	The library does not support block descriptors (00h).

Fibre Channel Logical Unit Page

The following table shows the format of the Fibre Channel Logical Unit page.

TABLE 6-37 Fibre Channel Logical Unit Page

Byte	Bit							
	7	6	5	4	3	2	1	0
0	PS (0)	SPF (0)	Page Code (18h)					
1	Page Length (06h)							
2	Reserved				Protocol Identifier (0)			
3	Reserved							EPDC (0)
4 to 7	(MSB)	Reserved						(LSB)

Fibre Channel Logical Unit Page Definitions:

PS	The Parameters Saveable bit is set to 0.
SPF	The library returns a value of 0 for the SubPage Format bit, indicating page_0 format is being used.
Protocol Identifier	This field is set to 0h indicating the Fibre Channel protocol.
EPDC	Enable Precise Delivery Checking bit is set to 0 (not supported)

Low Voltage Differential SCSI Logical Unit Page

The following table shows the format of the SCSI (LVD) Logical Unit Page.

TABLE 6-38 SCSI (LVD) Logical Unit Page

Byte	Bit							
	7	6	5	4	3	2	1	0
0	PS (0)	SPF (0)	Page Code (18h)					
1	Page Length (06h)							
2	Reserved				Protocol Identifier (1h)			
3 to 7	(MSB)	Reserved						(LSB)

SCSI (LVD) Logical Unit Page Definitions:

PS	The Parameters Saveable bit is set to 0.
SPF	The library returns a value of 0 for the SubPage Format bit, indicating page_0 format is being used.
Protocol Identifier	The field is set to 1h indicating the Parallel SCSI protocol.

Fibre Channel Port Control Page

The following table shows the format of the Fibre Channel Port Control page.

TABLE 6-39 Fibre Channel Port Control Page

Byte	Bit							
	7	6	5	4	3	2	1	0
0	PS (0)	Rsvd	Page Code (19h)					
1	Page Length (06h)							
2	Reserved				Protocol Identifier (0)			
3	DTFD	PLPB	DDIS	DLM	DSA	ALWI	DTIPE	DTOLI
4	Reserved							
5	Reserved							
6	Reserved					RR_TOV units		
7	Resource Recovery Time Out Value (RR_TOV)							

Fibre Channel Port Control Page Definitions:

PS	The Parameters Saveable bit is set to 0.
Protocol Identifier	This field is set to 0h indicating the Fibre Channel protocol.
DTFD	Disable Target Fabric Discovery ■ 0 = Public Loop behavior supported ■ 1 = Private Loop only supported
PLPB	Prevent Loop Port Bypass is set to 0
DDIS	Disable Discovery is set to 0
DLM	Disable Loop Master is set to 0
DSA	Disable Soft Address is set to 0
ALWI	Allow Login Without Loop Initialization is set to 0
DTIPE	Disable Target Initiated Port Enable is set to 0
DTOLI	Disable Target Originated Loop Initialization is set to 0
RR_TOV units	Resource Recovery Time Out Value Units will always be 100b = 10 second units
RR_TOV	Resource Recovery Time Out Value will always be 1Eh = 300 seconds

Low Voltage Differential SCSI Port Control Page

The following table shows the format of the SCSI (LVD) Port Control page.

TABLE 6-40 SCSI (LVD) Port Control Page

Byte	Bit							
	7	6	5	4	3	2	1	0
0	PS (0)	SPF (0)	Page Code (19h)					
1	Page Length (06h)							
2	Reserved				Protocol Identifier (1h)			
3	Reserved							
4 to 5	(MSB) Synchronous Transfer Timeout							(LSB)
6	Reserved							
7	Reserved							

SCSI (LVD) Port Control Page Definitions:

PS	The Parameters Saveable bit is set to 0.
SPF	The library returns a value of 0 for the SubPage Format bit, indicating page_0 format is being used.
Protocol Identifier	The field is set to 1h indicating the Parallel SCSI protocol.
Synchronous Transfer Timeout	<p>Indicates the maximum amount of time in 1 ms increments that SCSI target port shall wait before generating an error by doing an unexpected bus free. The SCSI target port shall only go to a BUS FREE phase if one of the following events cause the timer, once started, to not reset or reload before expiring.</p> <ul style="list-style-type: none"> ■ If there is a REQ transition when there are no outstanding REQS waiting for an ACK then load and start the timer. ■ If there is a REQ transition when there are any outstanding REQS waiting for an ACK then there is no effect on the timer. ■ If there is an ACK transition when there are outstanding REQS waiting for an ACK then load and start the timer. ■ If after an ACK transition there are no outstanding REQS waiting for an ACK then stop the timer. <p>A Synchronous Transfer Timeout field value of 0000h indicates that the function is disabled. A value of FFFFh indicates an unlimited period.</p>

Informational Exceptions TapeAlert Control Page

The following table shows the format of the Mode Sense (6) Informational Exceptions TapeAlert Control page.

TABLE 6-41 Informational Exceptions TapeAlert Control Page

Byte	Bit							
	7	6	5	4	3	2	1	0
0	PS (0)	SPF (0)	Page Code (1Ch)					
1	Page Length (0Ah)							
2	Perf (0)	Rsvd (0)	EBF (0)	EWasc (0)	DExcpt (1)	Test	Rsvd (0)	LogErr (0)
3	Reserved (0h)				MRIE (3h)			
4 to 7	(MSB) Interval Timer (LSB)							
8 to 11	(MSB) Report Count (LSB)							

Informational Exceptions TapeAlert Page Definitions:

PS	The Parameters Saveable bit is set to 0.
SPF	The library returns a value of 0 for the SubPage Format bit, indicating page_0 format is being used
Perf	The performance bit is 0, which indicates acceptance of informational exception operations that cause delays.
EBF	Enable Background Functions bit will always be 0.
EWasc	Enable Warning bit will always be 0.
DExcpt	The exception bit is 1, which indicates that the library disables all information exception operations ignoring the MRIE field. In this mode the software must poll the TapeAlert Log page
Test	The test operations bit is 0, which requests that the library not generate any false/test informational exception conditions.
LogErr	The log information exception conditions bit is 0, which indicates that logging of informational exception conditions is vendor-specific.
MRIE	This field indicates the method the tape library uses to report informational exception conditions. The field is set to 3h but is ignored because the DExcpt bit is on.
Interval Timer	Bytes 4 through 7 are set to 00h, which indicates that the library will only report the informational exception condition one time.
Report Count	Bytes 8 through 11 are set to the current report counter value.

Element Address Assignment Page Definition

This table defines the Element Address Assignment page of the Mode Sense (6) command.

TABLE 6-42 Mode Sense (6) Element Address Assignment Page

Byte	Bit								
	7	6	5	4	3	2	1	0	
0	PS (1)	Rsvd (0)	Page Code (1Dh)						
1	Parameter Length (12h)								
2 to 3	(MSB)	First Medium Transport Element Address						(LSB)	
4 to 5	(MSB)	Number of Medium Transport Elements						(LSB)	
6 to 7	(MSB)	First Storage Element Address						(LSB)	
8 to 9	(MSB)	Number of Storage Elements						(LSB)	
10 to 11	(MSB)	First Import/Export Element Address						(LSB)	
12 to 13	(MSB)	Number Import/Export Elements						(LSB)	
14 to 15	(MSB)	First Data Transfer Element Address						(LSB)	
16 to 17	(MSB)	Number Data Transfer Elements						(LSB)	
18 to 19	(MSB)	Reserved (00h)						(LSB)	

Mode Sense (6) Element Address Assignment Page Definitions:

PS	The Parameters Saveable bit specifies that the library can save this page to non-volatile memory and returns a value of 1.
Page Code	Identifies the Element Address Assignment mode page and returns a value of 1Dh.
Parameter Length	Indicates the amount of element address data following this byte and returns a value of 12h.
First Medium Transport Element Address	Identifies the address of the robot and returns a value of 0h.
Number of Medium Transport Elements	Identifies the number of hands within the library and returns a value of 0001h.
First Storage Element Address	Identifies the starting address of the cartridge tape storage cells. The default starting address is 03E8h
Number of Storage Elements	Identifies the number of cartridge tape storage cells within the library. The total number of cartridge tape storage cells depends on how the library is configured.
First Import / Export Element Address	Identifies the address of the first Import/Export element. The default starting address is 000Ah.
Number of Import / Export Elements	Identifies the total number of import/export cells.
First Data Transfer Element Address	Identifies the address of the first tape transport installed in the library. The default address is 1F4h.
Number of Data Transfer Elements	Identifies the number of tape drives in the library, and the library returns the configured count.

Transport Geometry Mode Page Definition

This table defines the Mode Sense Transport Geometry Mode page.

TABLE 6-43 Transport Geometry Mode Page

Byte	Bit								
	7	6	5	4	3	2	1	0	
0	PS (0)	Rsvd	Page Code (1Eh)						
1	Parameter Length (02h)								
2	Reserved (0)							Rotate (0)	
3	Member Number in Transport Element Set (00h)								

Transport Geometry Mode Page Definitions:

PS	The Parameters Saveable bit is set to 0.
Page Code	This field identifies the Transport Geometry mode page; the library returns a value of 1Eh.
Parameter Length	This field indicates the number of additional types of transport geometry descriptor data to follow the header. Each descriptor has two bytes of information. The library has one transport mechanism and returns a value of 02h.
Rotate	This field identifies the ability of the transport mechanism to handle two-sided media. The library does not use multiple-sided media and returns a value of 0.
Member Number in Transport Element Set	This field identifies the specific transport element in the system to which this descriptor is applied. The library has one transport element and returns a value of 00h.

Device Capabilities Page Definition

TABLE 6-44 defines the Device Capabilities page of the Mode Sense command.

TABLE 6-44 Device Capabilities Page

Byte	Bit							
	7	6	5	4	3	2	1	0
0	PS (0)	Rsvd (0)	Page Code (1Fh)					
1	Parameter Length (12h)							
2	Reserved (0h)				StorDT ¹ (1)	StorI/E ² (1)	StorST ³ (1)	StorMT ⁴ (0)
3	Reserved (0h)							
4	Reserved (0h)				MT->DT (0)	MT->I/E (0)	MT->ST (0)	MT->MT (0)
5	Reserved (0h)				ST->DT (1)	ST->I/E (1)	ST->ST (1)	ST->MT (0)
6	Reserved (0h)				I/E->DT (1)	I/E->I/E (1)	I/E->ST (1)	I/E->MT (0)
7	Reserved (0h)				DT->DT (1)	DT->I/E (1)	DT->ST (1)	DT->MT (0)
8 to 11	Reserved (00h)							
12	Reserved (0h)				MT<>D T (0)	MT<>I/ E (0)	MT<>ST (0)	MT<>M T (0)
13	Reserved (0h)				ST<>DT (0)	ST<>I/E (0)	ST<>ST (0)	ST<>MT (0)
14	Reserved (0h)				I/E<>D T (0)	I/E<>I/ E (0)	I/E<>ST (0)	I/E<>M T (0)
15	Reserved (0h)				DT->DT (0)	DT<>I/ E (0)	DT<>ST (0)	DT<>M T (0)
16 to 19	Reserved (00h)							
Notes: DT - Data Transfer Element (tape drive) I/E = Import/Export Element (cartridge access port cell and the PTP cells) ST = Storage Element (cartridge tape storage cell) MT= Medium Transport (hand)								

Device Capabilities Page Definitions:

PS	The Parameters Saveable bit is set to 0.
Page Code	This field identifies the Device Capabilities mode page and always contains a value of 1Fh.
Parameter Length	This field indicates the amount of device capabilities data following this byte. The library returns a value of 12h (18d).
StorDT	This field identifies the ability of a tape drive to perform the function of element storage. The library returns a value of 1.
StorI/E	This field identifies the ability of a CAP cell to perform the function of element storage. The library returns a value of 1.
StorST	This field identifies the ability of the cartridge tape storage cells to perform the function of element storage. The library returns a value of 1.
StorMT	This field identifies the ability of the hand to perform the function of element storage. The hand cannot be used as the source or destination of a move. The library returns a value of 0.
MT -> DT	This field identifies the support for the Move Medium command, where the source is the hand, and the destination is a tape drive. The library returns a value of 0.
MT -> I/E	This field identifies the support for the Move Medium command, where the source is the hand, and the destination is a CAP cell. The library returns a value of 0.
MT -> ST	This field identifies the support for the Move Medium command, where the source is the hand, and the destination is a cartridge tape storage cell. The library returns a value of 0.
MT -> MT	This field identifies the support for the Move Medium command, where both the source and the destination is the hand. The library returns a value of 0.
ST -> DT	This field identifies the support for the Move Medium command, where the source is a cartridge tape storage cell, and the destination is a tape drive. The library returns a value of 1.
ST -> I/E	This field identifies the support for the Move Medium command, where the source is a cartridge tape storage cell, and the destination is a CAP cell. The library returns a value of 1.
ST -> ST	This field identifies the support for the Move Medium command, where the source is a cartridge tape storage cell, and the destination is a cartridge tape storage cell. The library returns a value of 1.
ST -> MT	This field identifies the support for the Move Medium command, where the source is a cartridge tape storage cell, and the destination is the hand. The library returns a value of 0.
I/E -> DT	This field identifies the support for the Move Medium command, where the source is a CAP cell, and the destination is a tape drive. The library returns a value of 1.

Device Capabilities Page Definitions:

I/E-> I/E	This field identifies the support for the Move Medium command, where both the source, and the destination is a CAP cell. The library returns a value of 1.
I/E -> ST	This field identifies the support for the Move Medium command, where the source is a CAP cell, and the destination is a cartridge tape storage cell. The library returns a value of 1.
I/E -> MT	This field identifies the support for the Move Medium command, where the source is a CAP cell, and the destination is the hand. The library returns a value of 0.
DT -> DT	This field identifies the support for the Move Medium command, where the source, and the destination is a tape drive. The library returns a value of 1.
DT -> I/E	This field identifies the support for the Move Medium command, where the source is a tape drive, and the destination is a CAP cell. The library returns a value of 1.
DT -> ST	This field identifies the support for the Move Medium command, where the source is a tape drive, and the destination is a cartridge tape storage cell. The library returns a value of 1.
DT -> MT	This field identifies the support for the Move Medium command, where the source is a tape drive, and the destination 1 element is the hand. The library returns a value of 0.
MT < > DT	This field identifies the support for the Exchange Medium command, where the source and destination 2 elements are the hand, and the destination 1 element is a tape drive. The library returns a value of 0.
MT < > I/E	This field identifies the support for the Exchange Medium command, where the source and destination 2 elements are the hand, and the destination 1 element is a CAP cell. The library returns a value of 0.
MT < > ST	This field identifies the support for the Exchange Medium command, where the source and destination 2 elements are the hand, and the destination 1 element is a cartridge tape storage cell. The library returns a value of 0.
MT < > MT	This field identifies the support for the Exchange Medium command, where the source and destination 2 elements are the hand, and the destination 1 element is the hand. The library returns a value of 0.
ST < > DT	This field identifies the support for the Exchange Medium command, where the source and destination 2 elements are a cartridge tape storage cell, and the destination 1 element is a tape drive. The library returns a value of 0.
ST < > I/E	This field identifies the support for the Exchange Medium command, where the source and destination 2 elements are a cartridge tape storage cell, and the destination 1 element is a CAP cell. The library returns a value of 0.

Device Capabilities Page Definitions:

ST < > ST	This field identifies support for the Exchange Medium command, where the source and destination 2 elements are a cartridge tape storage cell, and the destination 1 element is a cartridge tape storage cell. The library returns a value of 0.
ST < > MT	This field identifies the support for the Exchange Medium command, where the source and destination 2 elements are a cartridge tape storage cell, and the destination 1 element is the hand. The library returns a value of 0.
I/E < > DT	This field identifies the support for the Exchange Medium command, where the source and destination 2 elements are a CAP cell, and the destination 1 element is a tape drive. The library returns a value of 0.
I/E < > I/E	This field identifies the support for the Exchange Medium command, where the source and destination 2 elements are a CAP cell, and the destination 1 element is a CAP cell. The library returns a value of 0.
I/E < > ST	This field identifies the support for the Exchange Medium command, where the source and destination 2 elements are a CAP cell, and the destination 1 element is a cartridge tape storage cell. The library returns a value of 0.
I/E < > MT	This field identifies the support for the Exchange Medium command, where the source and destination 2 elements are a CAP cell, and the destination 1 element is the hand. The library returns a value of 0.
DT < > DT	This field identifies the support for the Exchange Medium command, where the source and destination 2 elements are a tape drive, and the destination 1 element is a tape drive. The library returns a value of 0.
DT < > I/E	This field identifies the support for the Exchange Medium command, where the source and destination 2 elements are a tape drive, and the destination 1 element is a CAP cell. The library returns a value of 0.
DT < > ST	This field identifies the support for the Exchange Medium command, where the source and destination 2 elements are a tape drive, and the destination 1 element is a cartridge tape storage cell. The library returns a value of 0.
DT < > MT	This field identifies the support for the Exchange Medium command, where the source and destination 2 elements are a tape drive, and the destination 1 element is the hand. The library returns a value of 0.

Mode Sense (10)

The 10-byte Mode Sense command (5Ah) enables the library to report its operating mode parameters to the initiator.

TABLE 6-45 Mode Sense (10) Command

Byte	Bit							
	7	6	5	4	3	2	1	0
0	Operation Code (5Ah)							
1	Ignored			LLBA (0)	DBD	Reserved (0)		
2	Page Control		Page Code					
3	SubPage Code (00h)							
4 to 6	(MSB)		Reserved				(LSB)	
7 to 8	(MSB)		Allocation Length				(LSB)	
9	Control Byte							

Mode Sense (10) Command Definitions:

LLBA	The library returns a value of 0, indicating the LONGBLA bit shall be zero in the parameter data returned by the library.
DBD	Disable Block Descriptors is ignored.
Page Control	<p>Defines the type of parameters to be returned for the Mode Sense command, values include:</p> <hr/> <p>0h (00b) = Current Values: The library returns the current parameter values, including: Parameters set in the last successful Mode Select command. Default values if saved values are unavailable or invalid. Saved values if a MODE command has not been executed since the last power-on, interface reset, or Bus Device Reset.</p> <hr/> <p>1h (01b) = Changeable Values: The library returns the changeable parameter masks. All requested pages are returned Pages indicate which parameters are changeable by the initiator All bits of changeable parameters are set to 1 All bits of parameters that are not changeable are set to 0</p>

Page Control	2h (10b) = Default Values: The library returns the default values.
	Requested pages are returned with each supported parameter set to its default. Parameters not supported by the library are set to 0. Default values for the Element Address Assignment page are based on the configuration of the library.
	3h (11b) = Saved Values: The library returns the saved values.
	Requested pages are returned with supported parameters set to saved values. Parameters not supported by the library are set to 0. This option is valid only with mode pages that can be saved.
Page Code	Specifies which pages the library returns, including:
	<ul style="list-style-type: none"> ■ 00h = Physical Configuration page ■ 18h = Protocol Specific Logical Unit page ■ 19h = Protocol Specific Port Control page ■ 1Ch = Informational Exceptions TapeAlert Control page ■ 1Dh = Element Address Assignment page ■ 1Eh = Transport Geometry page ■ 1Fh = Device Capabilities page ■ 3Fh = All pages (in the above order) except the Physical Configuration page
SubPage Code	Not Supported. The library returns a value of 0.
Allocation Length	Specifies the length of the parameter list the library returns. The maximum length is 1A4h (420d) bytes.
	<p>The length varies based on the Page Code selected:</p> <ul style="list-style-type: none"> ■ 8 bytes for the parameter list header (always present) ■ 8 additional bytes for the Protocol Specific Logical Unit Control page ■ 8 additional bytes for the Protocol Specific Port Control page ■ 12 additional bytes for the Informational Exceptions TapeAlert page ■ 20 additional bytes for the Element Address Assignment page ■ 4 additional bytes for the Transport Geometry page ■ 20 additional bytes for the Device Capabilities page ■ 412 additional bytes for the Physical Configuration page
	The library transfers the number of bytes specified by the Allocation Length or the available Mode Sense data, whichever is less.

Mode Sense (10) Data

The library returns the following mode sense data:

- A eight-byte Mode Parameter Header followed by:
- One mode page or all mode pages in the order specified in the Page Code list. The mode pages available are those defined for medium changers in the Fibre Channel standard, including a Fibre Channel Logical Unit page, a Fibre Channel Port Control page, a TapeAlert page, an Element Address Assignment page, a Transport Geometry Mode page, and a Device Capabilities page and those defined for medium changers in the SCSI standard, including a SCSI Logical Unit page and a SCSI Port Control page.
- A 412 byte Physical Configuration Page
- The data can be truncated to the length specified in the allocation length field.

Mode Sense (10) Parameter Header Definition

The following table shows the Mode Sense Parameter Header page.

TABLE 6-46 Mode Sense Parameter Header Page

Byte	Bit							
	7	6	5	4	3	2	1	0
0	MSB of Mode Data Length							
1	LSB of Mode Data Length							
2	Reserved							
3	Reserved							
4	Reserved							
5	Reserved							
6	MSB of Block Descriptor Length							
7	LSB of Block Descriptor Length							

Mode Sense (10) Parameter Header Page Definitions:

Mode Data Length	This field indicates the number of bytes of parameter information available to be transferred to the initiator, regardless of the allocation length. This field excludes the Mode Data Length byte but includes three additional Mode Parameter Header bytes and any mode pages that follow.
Block Descriptor Length	The library does not support block descriptors (00h).

Fibre Channel Logical Unit Page

The following table shows the format of the Fibre Channel Logical Unit page.

TABLE 6-47 Fibre Channel Logical Unit Page

Byte	Bit							
	7	6	5	4	3	2	1	0
0	PS (0)	SPF (0)	Page Code (18h)					
1	Page Length (06h)							
2	Reserved				Protocol Identifier (0h)			
3	Reserved							EPDC (0)
4 to 7	(MSB)	Reserved						(LSB)

Fibre Channel Logical Unit Page Definitions:

PS	The Parameters Saveable bit is set to 0.
SPF	The library returns a value of 0 for the SubPage Format bit, indicating page_0 format is being used.
Protocol Identifier	This field is set to 0h indicating the Fibre Channel protocol.
EPDC	Enable Precise Delivery Checking bit is set to 0 (not supported)

Low Voltage Differential SCSI Logical Unit Page

The following table shows the format of the SCSI (LVD) Logical Unit Page.

TABLE 6-48 SCSI (LVD) Logical Unit Page

Byte	Bit							
	7	6	5	4	3	2	1	0
0	PS (0)	SPF (0)	Page Code (18h)					
1	Page Length (06h)							
2	Reserved				Protocol Identifier (1h)			
3 to 7	(MSB)	Reserved						(LSB)

SCSI Logical Unit Page Definitions:

PS	The Parameters Saveable bit is set to 0.
SPF	The library returns a value of 0 for the SubPage Format bit, indicating page_0 format is being used.
Protocol Identifier	The field is set to 1h indicating the Parallel SCSI protocol.

Fibre Channel Port Control Page

The following table shows the format of the Fibre Channel Port Control page.

TABLE 6-49 Fibre Channel Port Control Page

Byte	Bit							
	7	6	5	4	3	2	1	0
0	PS (0)	Rsvd	Page Code (19h)					
1	Page Length (06h)							
2	Reserved				Protocol Identifier (0h)			
3	DTFD	PLPB	DDIS	DLM	DSA	ALWI	DTIPE	DTOLI
4	Reserved							
5	Reserved							
6	Reserved					RR_TOV units		
7	Resource Recovery Time Out Value (RR_TOV)							

Fibre Channel Port Specific Control Page Definitions:

PS	The Parameters Saveable bit is set to 0.
Protocol Identifier	This field is set to 0h indicating the Fibre Channel protocol.
DTFD	Disable Target Fabric Discovery <ul style="list-style-type: none"> ■ 0 = Public Loop behavior supported ■ 1 = Private Loop only supported
PLPB	Prevent Loop Port Bypass will always be 0
DDIS	Disable Discovery will always be 0
DLM	Disable Loop Master will always be 0
DSA	Disable Soft Address will always be 0
ALWI	Allow Login Without Loop Initialization will always be 0
DTIPE	Disable Target Initiated Port Enable will always be 0
DTOLI	Disable Target Originated Loop Initialization will always be 0
RR_TOV units	Resource Recovery Time Out Value Units will always be 100b = 10 second units
RR_TOV	Resource Recovery Time Out Value will always be 1Eh = 300 seconds

Low Voltage Differential SCSI Port Control Page

The following table shows the format of the SCSI (LVD) Port Control page.

TABLE 6-50 SCSI Port Control Page

Byte	Bit							
	7	6	5	4	3	2	1	0
0	PS (0)	SPF (0)	Page Code (19h)					
1	Page Length (06h)							
2	Reserved				Protocol Identifier (1h)			
3	Reserved							
4 to 5	(MSB)		Synchronous Transfer Timeout				(LSB)	
6	Reserved							
7	Reserved							

SCSI Port Control Page Definitions:

PS	The Parameters Saveable bit is set to 0.
SPF	The library returns a value of 0 for the SubPage Format bit, indicating page_0 format is being used.
Protocol Identifier	The field is set to 1h indicating the Parallel SCSI protocol.
Synchronous Transfer Timeout	<p>Indicates the maximum amount of time in 1 ms increments that SCSI target port shall wait before generating an error by doing an unexpected bus free. The SCSI target port shall only go to a BUS FREE phase if one of the following events cause the timer, once started, to not reset or reload before expiring.</p> <ul style="list-style-type: none"> ■ If there is a REQ transition when there are no outstanding REqs waiting for an ACK then load and start the timer. ■ If there is a REQ transition when there are any outstanding REqs waiting for an ACK then there is no effect on the timer. ■ If there is an ACK transition when there are outstanding REqs waiting for an ACK then load and start the timer. ■ If after an ACK transition there are no outstanding REqs waiting for an ACK then stop the timer. <p>A Synchronous Transfer Timeout field value of 0000h indicates that the function is disabled. A value of FFFFh indicates an unlimited period.</p>

Informational Exceptions TapeAlert Control Page

The following table shows the format of the Mode Sense (10) Informational Exceptions TapeAlert Control page.

TABLE 6-51 Informational Exceptions TapeAlert Control Page

Byte	Bit							
	7	6	5	4	3	2	1	0
0	PS (0)	SPF (0)	Page Code (1Ch)					
1	Page Length (0Ah)							
2	Perf (0)	Rsvd (0)	EBF (0)	EWasc (0)	DExcpt (1)	Test	Rsvd (0)	LogErr (0)
3	Reserved (0h)				MRIE (3h)			
4 to 7	(MSB) Interval Timer							(LSB)
8 to 11	(MSB) Report Count							(LSB)

Informational Exceptions TapeAlert Control Page Definitions:

PS	The Parameters Saveable bit is set to 0.
SPF	The library returns a value of 0 for the SubPage Format bit, indicating page_0 format is being used.
Perf	The performance bit is 0, which indicates acceptance of informational exception operations that cause delays.
EBF	Enable Background Functions bit will always be 0.
EWasc	Enable Warning bit will always be 0.
DExcpt	The exception bit is 1, which indicates that the library disables all information exception operations ignoring the MRIE field. Note: In this mode the software must poll the TapeAlert Log page.
Test	The test operations bit is 0, which requests that the library not generate any false/test informational exception conditions.
LogErr	The log information exception conditions bit is 0, which indicates that logging of informational exception conditions is vendor-specific.
MRIE	This field indicates the method the tape library uses to report informational exception conditions. The field is set to 3h but is ignored because the DExcpt bit is on.
Interval Timer	Bytes 4 through 7 are set to 00h, which indicates that the library will only report the informational exception condition one time.
Report Count	Bytes 8 through 11 are set to the current report counter value.

Element Address Assignment Page Definition

This table defines the Element Address Assignment page of the Mode Sense (10) command.

TABLE 6-52 Element Address Assignment Page

Byte	Bit							
	7	6	5	4	3	2	1	0
0	PS (1)	Rsvd (0)	Page Code (1Dh)					
1	Parameter Length (12h)							
2 to 3	(MSB) First Medium Transport Element Address							(LSB)
4 to 5	(MSB) Number of Medium Transport Elements							(LSB)
6 to 7	(MSB) First Storage Element Address							(LSB)
8 to 9	(MSB) Number of Storage Elements							(LSB)
10 to 11	(MSB) First Import/Export Element Address							(LSB)
12 to 13	(MSB) Number Import/Export Elements							(LSB)
14 to 15	(MSB) First Data Transfer Element Address							(LSB)
16 to 17	(MSB) Number Data Transfer Elements							(LSB)
18 to 19	Reserved (00h)							

Element Address Assignment Page Definitions:

PS	The Parameters Saveable bit specifies that the library can save this page to non-volatile memory and returns a value of 1.
Page Code	Identifies the Element Address Assignment mode page and returns a value of 1Dh.
Parameter Length	Indicates the amount of element address data following this byte and returns a value of 12h.
First Medium Transport Element Address	Identifies the address of the robot and returns a value of 0h.
Number of Medium Transport Elements	Identifies the number of hands within the library and returns a value of 0001h.
First Storage Element Address	Identifies the starting address of the cartridge tape storage cells. The default starting address is 03E8h
Number of Storage Elements	Identifies the number of cartridge tape storage cells within the library. The total number of cartridge tape storage cells depends on how the library is configured.
First Import / Export Element Address	Identifies the address of the first Import/Export element. The default starting address is 000Ah.
Number of Import / Export Elements	Identifies the total number of import/export cells.
First Data Transfer Element Address	Identifies the address of the first tape transport installed in the library. The default address is 1F4h.
Number of Data Transfer Elements	Identifies the number of tape drives in the library, and the library returns the configured count.

Transport Geometry Mode Page Definition

This table defines the Mode Sense Transport Geometry Mode page.

TABLE 6-53 Transport Geometry Mode Page

Byte	Bit							
	7	6	5	4	3	2	1	0
0	PS (0)	Rsvd (0)	Page Code (1Eh)					
1	Parameter Length (02h)							
2	Reserved (0)							Rotate (0)
3	Member Number in Transport Element Set (00h)							

Transport Geometry Mode Page Definitions:

PS	The Parameters Saveable bit is set to 0.
Page Code	This field identifies the Transport Geometry mode page. The library returns a value of 1Eh.
Parameter Length	This field indicates the number of additional types of transport geometry descriptor data to follow the header. Each descriptor has two bytes of information. The library has one transport mechanism and returns a value of 02h.
Rotate	This field identifies the ability of the transport mechanism to handle two-sided media. The library does not use multiple-sided media and returns a value of 0.
Member Number in Transport Element Set	This field identifies the specific transport element in the system to which this descriptor is applied. The library has one transport element and returns a value of 00h.

Device Capabilities Page Definition

TABLE 6-54 defines the Device Capabilities page of the Mode Sense (10) command.

TABLE 6-54 Device Capabilities Page

Byte	Bit							
	7	6	5	4	3	2	1	0
0	PS (0)	Rsvd (0)	Page Code (1Fh)					
1	Parameter Length (12h)							
2	Reserved (0h)				StorDT ¹ (1)	StorI/E ² (1)	StorST ³ (1)	StorMT ⁴ (0)
3	Reserved (0h)							
4	Reserved (0h)				MT->DT (0)	MT->I/E (0)	MT->ST (0)	MT->MT (0)
5	Reserved (0h)				ST->DT (1)	ST->I/E (1)	ST->ST (1)	ST->MT (0)
6	Reserved (0h)				I/E->DT (1)	I/E->I/E (1)	I/E->ST (1)	I/E->MT (0)
7	Reserved (0h)				DT->DT (1)	DT->I/E (1)	DT->ST (1)	DT->MT (0)
8 to 11	Reserved (00h)							
12	Reserved (0h)				MT<>D T (0)	MT<>I/ E (0)	MT<>ST (0)	MT<>M T (0)
13	Reserved (0h)				ST<>DT (0)	ST<>I/E (0)	ST<>ST (0)	ST<>MT (0)
14	Reserved (0h)				I/E<>D T (0)	I/E<>I/ E (0)	I/E<>ST (0)	I/E<>M T (0)
15	Reserved (0h)				DT->DT (0)	DT<>I/ E (0)	DT<>ST (0)	DT<>M T (0)
16 to 19	Reserved (00h)							
<p>Notes: DT - Data Transfer Element (tape drive) I/E = Import/Export Element (cartridge access port cell and the PTP cells) ST = Storage Element (cartridge tape storage cell) MT= Medium Transport (hand)</p>								

Device Capabilities Page Definitions:

PS	The Parameters Saveable bit is set to 0.
Page Code	The Page Code field identifies the Device Capabilities mode page and always contains a value of 1Fh.
Parameter Length	This field indicates the amount of device capabilities data following this byte. The library returns a value of 12h (18d).
StorDT	This field identifies the ability of a tape drive to perform the function of element storage. The library returns a value of 1.
StorI/E	This field identifies the ability of a CAP cell to perform the function of element storage. The library returns a value of 1.
StorST	This field identifies the ability of the cartridge tape storage cells to perform the function of element storage. The library returns a value of 1.
StorMT	This field identifies the ability of the hand to perform the function of element storage. The hand cannot be used as the source or destination of a move. The library returns a value of 0.
MT -> DT	This field identifies the support for the Move Medium command, where the source is the hand, and the destination is a tape drive. The library returns a value of 0.
MT -> I/E	This field identifies the support for the Move Medium command, where the source is the hand, and the destination is a CAP cell. The library returns a value of 0.
MT -> ST	This field identifies the support for the Move Medium command, where the source is the hand, and the destination is a cartridge tape storage cell. The library returns a value of 0.
MT -> MT	This field identifies the support for the Move Medium command, where both the source and the destination is the hand. The library returns a value of 0.
ST -> DT	This field identifies the support for the Move Medium command, where the source is a cartridge tape storage cell, and the destination is a tape drive. The library returns a value of 1.
ST -> I/E	This field identifies the support for the Move Medium command, where the source is a cartridge tape storage cell, and the destination is a CAP cell. The library returns a value of 1.
ST -> ST	This field identifies the support for the Move Medium command, where the source is a cartridge tape storage cell, and the destination is a cartridge tape storage cell. The library returns a value of 1.
ST -> MT	This field identifies the support for the Move Medium command, where the source is a cartridge tape storage cell, and the destination is the hand. The library returns a value of 0.
I/E -> DT	This field identifies the support for the Move Medium command, where the source is a CAP cell, and the destination is a tape drive. The library returns a value of 1.

I/E -> I/E	This field identifies the support for the Move Medium command, where both the source, and the destination is a CAP cell. The library returns a value of 1.
I/E -> ST	This field identifies the support for the Move Medium command, where the source is a CAP cell, and the destination is a cartridge tape storage cell. The library returns a value of 1.
I/E -> MT	This field identifies the support for the Move Medium command, where the source is a CAP cell, and the destination is the hand. The library returns a value of 0.
DT -> DT	This field identifies the support for the Move Medium command, where the source, and the destination is a tape drive. The library returns a value of 1.
DT -> I/E	This field identifies the support for the Move Medium command, where the source is a tape drive, and the destination is a CAP cell. The library returns a value of 1.
DT -> ST	This field identifies the support for the Move Medium command, where the source is a tape drive, and the destination is a cartridge tape storage cell. The library returns a value of 1.
DT -> MT	This field identifies the support for the Move Medium command, where the source is a tape drive, and the destination 1 element is the hand. The library returns a value of 0.
MT < > DT	This field identifies the support for the Exchange Medium command, where the source and destination 2 elements are the hand, and the destination 1 element is a tape drive. The library returns a value of 0.
MT < > I/E	This field identifies the support for the Exchange Medium command, where the source and destination 2 elements are the hand, and the destination 1 element is a CAP cell. The library returns a value of 0.
MT < > ST	This field identifies the support for the Exchange Medium command, where the source and destination 2 elements are the hand, and the destination 1 element is a cartridge tape storage cell. The library returns a value of 0.
MT < > MT	This field identifies the support for the Exchange Medium command, where the source and destination 2 elements are the hand, and the destination 1 element is the hand. The library returns a value of 0.
ST < > DT	This field identifies the support for the Exchange Medium command, where the source and destination 2 elements are a cartridge tape storage cell, and the destination 1 element is a tape drive. The library returns a value of 0.
ST < > I/E	This field identifies the support for the Exchange Medium command, where the source and destination 2 elements are a cartridge tape storage cell, and the destination 1 element is a CAP cell. The library returns a value of 0.
ST < > ST	This field identifies support for the Exchange Medium command, where the source and destination 2 elements are a cartridge tape storage cell, and the destination 1 element is a cartridge tape storage cell. The library returns a value of 0.

ST < > MT	This field identifies the support for the Exchange Medium command, where the source and destination 2 elements are a cartridge tape storage cell, and the destination 1 element is the hand. The library returns a value of 0.
I/E < > DT	This field identifies the support for the Exchange Medium command, where the source and destination 2 elements are a CAP cell, and the destination 1 element is a tape drive. The library returns a value of 0.
I/E < > I/E	This field identifies the support for the Exchange Medium command, where the source and destination 2 elements are a CAP cell, and the destination 1 element is a CAP cell. The library returns a value of 0.
I/E < > ST	This field identifies the support for the Exchange Medium command, where the source and destination 2 elements are a CAP cell, and the destination 1 element is a cartridge tape storage cell. The library returns a value of 0.
I/E < > MT	This field identifies the support for the Exchange Medium command, where the source and destination 2 elements are a CAP cell, and the destination 1 element is the hand. The library returns a value of 0.
DT < > DT	This field identifies the support for the Exchange Medium command, where the source and destination 2 elements are a tape drive, and the destination 1 element is a tape drive. The library returns a value of 0.
DT < > I/E	This field identifies the support for the Exchange Medium command, where the source and destination 2 elements are a tape drive, and the destination 1 element is a CAP cell. The library returns a value of 0.
DT < > ST	This field identifies the support for the Exchange Medium command, where the source and destination 2 elements are a tape drive, and the destination 1 element is a cartridge tape storage cell. The library returns a value of 0.
DT < > MT	This field identifies the support for the Exchange Medium command, where the source and destination 2 elements are a tape drive, and the destination 1 element is the hand. The library returns a value of 0.

Physical Configuration Page Definition

TABLE 6-55 defines the Physical Configuration page of the Mode Sense (10) command. This Mode Sense command enables the library to report a physical description of the library configuration.

This table provides an example of the information contained in each 5-byte group:

Byte	Bit
6	Bit map of drives for column 1, module 1
7	Number of CAP cells for column 1, module 1
8	Number of PTP cells for column 1, module 1
9	Number of reserved cells for column 1, module 1
10	Number of storage cells for column 1, module 1

Notes:

1. CAP = Cartridge Access Port
2. PTP = Pass-thru Port
3. Each group indicates the column #, module #, a bit map of drives, CAP cells, PTP cells, reserved cells and storage cells for the indicated library column and module.
The example above—Bytes 6 to 10—show numbers for column 1, module 1 and would break down as follows:
The bit map for drives specifies which row of this module and column contains a drive.
 - Bit 0 specifies row 1
 - Bit 1 specifies row 2
 - Bit 2 specifies row 3
 - Bit 3 specifies row 4
 - A 1 in the bit position signifies the drive is present,
A 0 zero signifies no drive at this location.

The list in **TABLE 6-55** describes the possible modules and physically accessible cell combinations. For instance, depending on the module type, the last row or rows, in the last module of the library, are not accessible. Only the accessible cells are listed in the number of the cells for that specific module and column. The physical module types do not account for customer configured options.

There are customer configured options, such as restricting the total cell count, changing caps to cells, and setting aside reserved cells. These options are reflected in the cell counts for the columns and modules.

To count physical rows of a cell type using the above information, always add storage cell rows last in a column. Generally a column within a module only has one cell type.

Two exceptions for this are the base unit CAP column (column number 8) which has CAP cells and storage cells below it. The base unit also has an area for reserved cells in column 1. If reserved cells are configured, they will come first in the row numbering.

To map SCSI addresses to module, row, column addresses, assign starting with the lowest numbered row, column and module for a cell type. Increase by row within a column of a module, and then increase columns for that module, then increase to the next module.

TABLE 6-55 Physical Configuration Page

Byte	Bit							
	7	6	5	4	3	2	1	0
0	PS (0)	Rsvd (0)	Page Code (0)					
1 to 2	(MSB) Parameter Length (199h)							(LSB)
3	Number of installed modules							
4	Module Type—Module 1							
5	Number of columns in Module 1							
6 to 10	Numbers for column 1, module 1							
11	Reserved (0h)							
12 to 16	Numbers for column 2, module 1							
17	Reserved (0)							
18 to 22	Numbers for column 3, module 1							
23	Reserved (0)							
24 to 28	Numbers for column 4, module 1							
29	Reserved (0)							
30 to 34	Numbers for column 5, module 1							
35	Reserved (0)							
36 to 40	Numbers for column 6, module 1							
41	Reserved (0)							
42 to 46	Numbers for column 7, module 1							
47	Reserved (0)							

TABLE 6-55 Physical Configuration Page (Continued)

Byte	Bit							
	7	6	5	4	3	2	1	0
48 to 52	Numbers for column 8, module 1							
53	Reserved (0)							
54 to 58	Numbers for column 9, module 1							
59	Reserved (0)							
60 to 64	Numbers for column 10, module 1							
65	Reserved (0)							
66 to 70	Numbers for column 11, module 1							
71	Reserved (0)							
72	Module Type—Module 2							
73	Number of columns in module 2							
74 to 78	Numbers for column 1, module 2							
79	Reserved (0)							
80 to 84	Numbers for column 2, module 2							
85	Reserved (0)							
86 to 90	Numbers for column 3, module 2							
91	Reserved (0)							
92 to 96	Numbers for column 4, module 2							
97	Reserved (0)							
98 to 102	Numbers for column 5, module 2							
103	Reserved (0)							

TABLE 6-55 Physical Configuration Page (Continued)

Byte	Bit							
	7	6	5	4	3	2	1	0
104 to 108	Numbers for column 6, module 2							
109	Reserved (0)							
110 to 114	Numbers for column 7, module 2							
115	Reserved (0)							
116 to 120	Numbers for column 8, module 2							
121	Reserved (0)							
122 to 126	Numbers for column 9, module 2							
127	Reserved (0)							
128 to 132	Numbers for column 10, module 2							
133	Reserved (0)							
134 to 138	Numbers for column 11, module 2							
139	Reserved (0)							
140	Module Type—Module 3							
141	Number of columns in module 3							
142 to 146	Numbers for column 1, module 3							
147	Reserved (0)							
148 to 152	Numbers for column 2, module 3							
153	Reserved (0)							
154 to 158	Numbers for column 3, module 3							
159	Reserved (0)							

TABLE 6-55 Physical Configuration Page (Continued)

Byte	Bit							
	7	6	5	4	3	2	1	0
160 to 164	Numbers for column 4, module 3							
165	Reserved (0)							
166 to 170	Numbers for column 5, module 3							
171	Reserved (0)							
172 to 176	Numbers for column 6, module 3							
177	Reserved (0)							
178 to 182	Numbers for column 7, module 3							
183	Reserved (0)							
184 to 188	Numbers for column 8, module 3							
189	Reserved (0)							
190 to 194	Numbers for column 9, module 3							
195	Reserved (0)							
196 to 200	Numbers for column 10, module 3							
201	Reserved (0)							
202 to 206	Numbers for column 11, module 3							
207	Reserved (0)							
208	Module Type—Module 4							
209	Number of columns in module 4							
210 to 214	Numbers for column 1, module 4							
215	Reserved (0)							

TABLE 6-55 Physical Configuration Page (Continued)

Byte	Bit							
	7	6	5	4	3	2	1	0
216 to 220	Numbers for column 2, module 4							
221	Reserved (0)							
222 to 226	Numbers for column 3, module 4							
227	Reserved (0)							
228 to 232	Numbers for column 4, module 4							
233	Reserved (0)							
234 to 238	Numbers for column 5, module 4							
239	Reserved (0)							
240 to 244	Numbers for column 6, module 4							
245	Reserved (0)							
246 to 250	Numbers for column 7, module 4							
251	Reserved (0)							
252 to 256	Numbers for column 8, module 4							
257	Reserved (0)							
258 to 262	Numbers for column 9, module 4							
263	Reserved (0)							
264 to 268	Numbers for column 10, module 4							
269	Reserved (0)							
270 to 274	Numbers for column 11, module 4							

TABLE 6-55 Physical Configuration Page (Continued)

Byte	Bit							
	7	6	5	4	3	2	1	0
275	Reserved (0)							
276	Module Type—Module 5							
277	Number of columns in module 5							
278 to 282	Numbers for column 1, module 5							
283	Reserved (0)							
284 to 288	Numbers for column 2, module 5							
289	Reserved (0)							
290 to 294	Numbers for column 3, module 5							
295	Reserved (0)							
296 to 300	Numbers for column 4, module 5							
301	Reserved (0)							
302 to 306	Numbers for column 5, module 5							
307	Reserved (0)							
308 to 312	Numbers for column 6, module 5							
313	Reserved (0)							
314 to 318	Numbers for column 7, module 5							
319	Reserved (0)							
320 to 324	Numbers for column 8, module 5							
325	Reserved (0)							
326 to 330	Numbers for column 9, module 5							
331	Reserved (0)							

TABLE 6-55 Physical Configuration Page (Continued)

Byte	Bit							
	7	6	5	4	3	2	1	0
332 to 336	Numbers for column 10, module 5							
337	Reserved (0)							
338 to 342	Numbers for column 11, module 5							
343	Reserved (0)							
344	Module Type—Module 6							
345	Number of columns in module 6							
346 to 350	Numbers for column 1, module 6							
351	Reserved (0)							
352 to 356	Numbers for column 2, module 6							
357	Reserved (0)							
358 to 362	Numbers for column 3, module 6							
363	Reserved (0)							
364 to 368	Numbers for column 4, module 6							
369	Reserved (0)							
370 to 374	Numbers for column 5, module 6							
375	Reserved (0)							
376 to 380	Numbers for column 6, module 6							
381	Reserved (0)							
382 to 386	Numbers for column 7, module 6							
387	Reserved (0)							

TABLE 6-55 Physical Configuration Page (Continued)

Byte	Bit							
	7	6	5	4	3	2	1	0
388 to 392	Numbers for column 8, module 6							
393	Reserved (0)							
394 to 398	Numbers for column 9, module 6							
399	Reserved (0)							
400 to 404	Numbers for column 10, module 6							
405	Reserved (0)							
406 to 410	Numbers for column 11, module 6							
411	Reserved (0)							

TABLE 6-56 Module Type Definitions

Module Type Field Definitions	
0	Module not installed
1	The last installed 4U module with drives
2	The last installed 4U module with storage cells in the back
3	A 4U module with drives
4	A 4U module with storage cells followed by a module with drives
5	A 4U module with storage cells followed by a module with storage cells
6	The last installed 4U card unit
7	A 4U card unit
8	The last installed 8U module with drives
9	The last installed 8U module with storage cells in the back, below a module with drives in the back
10	The last installed 8U module with storage cells in the back, below a module with storage cells in the back
11	An 8U module with drives
12	An 8U module with storage cells in the back between modules with drives in the back
13	An 8U module with storage cells in the back below a module containing storage cells, and above a module with drives in the back
14	An 8U module with storage cells in the back below a module containing drives, and above a module with storage cells in the back

TABLE 6-56 Module Type Definitions

Module Type Field Definitions	
15	An 8U module with storage cells in the back between modules with storage cells in the back
16	The last installed 8U module (with CAP) with drives in the back
17	An 8U module (with CAP) with drives in the back
18	The last installed 8U module (with CAP) with with storage cells in the back below a module containing drives
19	The last installed 8U module (with CAP) with with storage cells in the back below a module containing storage cells in the back
20	An 8U module (with CAP) with storage cells in the back between modules with drives in the back
21	An 8U module (with CAP) with storage cells in the back below a module containing storage cells, and above a module with drives in the back
22	An 8U module (with CAP) with storage cells in the back below a module containing drives, and above a module with storage cells in the back
23	An 8U module (with CAP) with storage cells in the back between modules with storage cells in the back
24	BASE module only, no other modules
25	BASE module with drives in the back
26	The last installed 8U multi-media module with drives
27	The last installed 8U multi-media module with storage cells in the back, below a module with drives in the back
28	The last installed 8U multi-media module with storage cells in the back, below a module with storage cells in the back
29	An 8U multi-media module with drives
30	An 8U multi-media module with storage cells in the back between modules with drives in the back
31	An 8U multi-media module with storage cells in the back below a module containing storage cells, and above a module with drives in the back
32	An 8U multi-media module with storage cells in the back below a module containing drives, and above a module with storage cells in the back
33	An 8U multi-media module with storage cells in the back between modules with storage cells in the back
34	The last installed 8U multi-media module with drives in the back
35	An 8U multi-media module (with CAP) with drives in the back
36	The last installed 8U multi-media module (with CAP) with storage cells in the back, below a module with drives in the back
37	The last installed 8U multi-media module (with CAP) with storage cells in the back, below a module with storage cells in the back
38	An 8U multi-media module (with CAP) with storage cells in the back between modules with drives in the back
39	An 8U multi-media module (with CAP) with storage cells in the back below a module containing storage cells, and above a module with drives in the back
40	An 8U multi-media module (with CAP) with storage cells in the back below a module containing drives, and above a module with storage cells in the back
41	An 8U multi-media module (with CAP) with storage cells in the back between modules with storage cells in the back
42	BASE multi-media module only, no other modules
43	BASE multi-media module with drives in the back

Move Medium

The Move Medium command (A5h) moves a cartridge tape from one specific element location to another specific element location.

The Mode Sense command provides a matrix with the valid source and destination element combinations for the Move Medium command.

The Fast Load option on the library controls the completion of the move command when the destination element is a tape drive. If the fast load option is disabled, the library performs the move motion, and waits until the tape drive load operation completes before returning status for the move command. When the fast load option is enabled, the library performs the move motion, and verifies the tape drive load starts before returning status for the move command.

TABLE 6-57 Move Medium Command

Byte	Bit							
	7	6	5	4	3	2	1	0
0	Operation Code (A5h)							
1	Ignored			Reserved (00h)				
2 to 3	(MSB) Transport Element Address							(LSB)
4 to 5	(MSB) Source Element Address							(LSB)
6 to 7	(MSB) Destination Element Address							(LSB)
8	Reserved (00h)							
9	Reserved (00h)							
10	Reserved (00h)							Invert (0)
11	Move Option		Control Byte (00h)					

Move Medium Command Definitions:

Transport Element Address	This field defines the robot element to use and should contain the element address 00h. A value of 00h indicates use of the default hand. If any other value is entered it will be ignored.
Source Element Address	This field is the element address from which the cartridge tape is to be removed. This may be a storage cell, a CAP cell, or a tape drive.
Destination Element Address	This field is the element address where the cartridge tape is to be placed. This may be a storage cell, a CAP cell, or a tape drive.
Invert	The library does not support this function and requires a value of 0.
Move Option	<p>These two bits define optional operations associated with the Move Medium command.</p> <ul style="list-style-type: none"> ■ 00 = The library performs a normal move medium operation ■ 10 = The library performs a mount operation with write protect enabled. That is, the user can read the data on the cartridge but cannot write to the cartridge. This option is valid only when the destination element address is a data transfer element. If the destination data transfer element (tape drive) does not support this feature or fails to acknowledge the write-protected mount option, the mount fails. In either case, the library returns the Hardware Error sense key (04) with an ASC of 40 and an ASCQ of 02 (Drive Error). ■ 11 = The data transfer element specified in the source element field performs a rewind, followed by a unload operation and then the move medium operation. This option is valid only when the source element address is a data transfer element. Use this option with care because it might interfere with operations being performed on the data path of the data transfer element.

Persistent Reserve In

The Persistent Reserve In (5Eh) and Persistent Reserve Out (5Fh) commands resolve contention among multiple initiators and multiple-port targets within the system.

The Persistent Reserve In command is used by initiators to obtain information about active registrations or an active reservation.

TABLE 6-58 Persistent Reserve In Command

Byte	Bit							
	7	6	5	4	3	2	1	0
0	Operation Code (5Eh)							
1	Ignored			Service Action				
2	Reserved (00h)							
3	Reserved (00h)							
4	Reserved (00h)							
5	Reserved (00h)							
6	Reserved (00h)							
7 to 8	(MSB) Allocation Length							(LSB)
9	Control (00h)							

Persistent Reserve In Command Descriptions:

Service Action This field defines the type of request that is being made to the initiator.

Valid values are 00h, 01h, and 02h.

- 00h = Returns Read Keys Data (see [TABLE 6-59](#))
- 01h = Returns Read Reservations Data (see [TABLE 6-60](#) and [TABLE 6-61](#))
- 02h = Returns Report Capabilities Data (see [TABLE 6-62](#))

Values 03h through 1Fh are reserved.

Allocation Length This field indicates how much space has been reserved for the returned parameter list. If the length is not sufficient to contain the entire parameter list, the parameter list will be incomplete. However, a partial list is not an error.

Read Keys Data

The Read Keys service action requests that the initiator return a list of all the current Reservation keys it has registered.

TABLE 6-59 shows the format of the parameter data returned in response to a Persistent Reserve In command with the Read Keys service action.

TABLE 6-59 Read Keys Data

Byte	Bit							
	7	6	5	4	3	2	1	0
0								
0 to 3	(MSB)	PRGeneration						(LSB)
4 to 7	(MSB)	Additional Length (n-7)						(LSB)
	Reservation Key List							
8 to 15	(MSB)	First Reservation Key						(LSB)
More	Additional Reservation Keys							
n-7 to n	(MSB)	Last Reservation Key						(LSB)

Read Keys Data Definitions:

PRGeneration	<p>This value is a 32-bit counter that is incremented every time a Persistent Reserve Out command requests a Register, Register & Ignore, a Clear, a Preempt, or a Preempt and Abort operation.</p> <p>It allows the application client to determine if another application client has changed the configuration.</p> <p>This counter is set to zero after a Power-On-Reset.</p>
Additional Length	This field indicates the number of bytes in the reservation key list.
Reservation Key List	These fields contain all the eight-byte reservation keys that have been registered with the library through a Persistent Reserve Out command.

Read Reservations Data

The Read Reservations service action requests that the initiator return a description of all current Reservation keys it has registered.

See [TABLE 6-60](#) for the format of the parameter data returned in response to a Persistent Reserve In command with the Read Reservations service action.

TABLE 6-60 Read Reservations Data

Byte	Bit							
	7	6	5	4	3	2	1	0
0 to 3	PRGeneration (MSB) (LSB)							
4 to 7	Additional Length (n-7) (MSB) (LSB)							
8 to n	Reservation Descriptor (MSB) (LSB)							

Read Reservations Data Definitions:

PRGeneration	<p>This value is a 32-bit counter that is incremented every time a Persistent Reserve Out command requests a Register, Register & Ignore, a Clear, a Preempt, or a Preempt and Abort operation.</p> <p>It allows the application client to determine if another application client has changed the configuration.</p> <p>This counter is set to zero after a Power-On-Reset.</p>
Additional Length	<p>This field indicates the number of bytes in the list of reservation descriptors: 0 = No Reservation held 16 = Active Reservation Data</p>
Reservation Descriptors	<p>Each persistent reservation for a logical unit has one reservation descriptor that has the format shown in TABLE 6-61.</p>

TABLE 6-61 Reservation Descriptors Format

Byte	Bit							
	7	6	5	4	3	2	1	0
0 to 7	(MSB) Reservation Key (LSB)							
8 to 11	(MSB) Obsolete (LSB)							
12	Reserved (00h)							
13	Scope				Type			
14 to 15	Obsolete (00h)							

Reservation Descriptors Format Definitions:

Reservation Key	This value indicates the reservation key for the descriptor data that follows.
Scope	The value in the Scope field indicates whether a persistent reservation applies to an entire logical unit or to an element. The only valid value is 0h. 0h = The persistent reservation applies to the logical unit
Type	This value specifies the characteristics of the persistent reservation. Valid values are 3h and 6h. <ul style="list-style-type: none"> ■ 3h = Exclusive Access: This value indicates that the initiator holding the persistent reservation has exclusive access. Some commands (such as Move Medium) are only allowed for the persistent reservation holder. ■ 6h = Exclusive Access, Registrants Only: This value indicates that any currently registered initiator has exclusive access. Some commands (such as Move Medium) are only allowed for registered I_T nexuses.

Persistent Reserve In Data for Report Capabilities

The format for the parameter data provided in response to a Persistent Reserve In command with the Report Capabilities service action is shown in [TABLE 6-62](#).

TABLE 6-62 Persistent Reserve In Parameter Data for Report Capabilities

Byte	Bit							
	7	6	5	4	3	2	1	0
0 to 1	(MSB) Length (0008h) (LSB)							
2	Reserved (00h)				SIP_C (0)	ATP_C (0)	Rsvd (0)	PTPL_C (1)
3	TMV (1)	Reserved (00h)						PTPL_A
4 to 5	(MSB) Persistent Reservation Mask (LSB)							
6 to 7	Reserved (00h)							

Persistent Reserve In parameter data for Report Capabilities Definitions:

Length	This field indicates the length in bytes of the parameter data.
SIP_C	The library will return a value of 0 for the Specify Initiator Ports Capable bit, indicating the SPEC_I_PT bit in the PERSISTENT RESERVE OUT command parameter data is not supported.
ATP_C	The library will return a value of 0, indicating the ALL_TG_PT bit in the PERSISTENT RESERVE OUT command parameter data is not supported
PTPL_C	Persist Through Power Loss Capable bit <ul style="list-style-type: none"> ■ 0 = The library does not support the persist through power loss capability for persistent reservations and the APTPL bit in the in PERSISTENT RESERVE OUT command parameter data ■ 1 = The library supports the persist through power loss capability for persistent reservations and the APTPL bit in the in PERSISTENT RESERVE OUT command parameter data
TMV	Type Mask Valid bit <ul style="list-style-type: none"> ■ 0 = The PERSISTENT RESERVATION TYPE MASK field shall be ignored ■ 1 = The PERSISTENT RESERVATION TYPE MASK field contains a bit map indicating which persistent reservation types are supported by the library.
PTPL_A	Persist Through Power Loss Activated bit <ul style="list-style-type: none"> ■ The library will return a value of 0, indicating the Persist Through Power Loss Activated bit is not supported.

The Persistent Reservation Type Mask field contains a bit map that indicates the persistent reservation types that are supported by the library.

TABLE 6-63 Read Reservations Parameter Data

Byte	Bit							
	7	6	5	4	3	2	1	0
4	WR_EX_AR (0)	EX_AC_RO (1)	WR_EX_RO (0)	Rsvd	EX_AC (1)	Rsvd	WR_EX (0)	Rsvd
5	Reserved							EX_AC_AR (0)

Read Reservations Parameter Data Definitions:

WR_EX_AR	The library returns a value of 0, indicating the Write Exclusive-All Registrants persistent reservation type is not supported.
EX_AC_RO	The library returns a value of 1, indicating the Exclusive Access-Registrants Only persistent reservation type is supported.
WR_EX_RO	The library returns a value of 0, indicating the Write Exclusive-Registrants Only persistent reservation type is not supported.
EX_AC	The library returns a value of 1, indicating the Exclusive Access- persistent reservation type is supported.
WR_EX	The library returns a value of 0, indicating the Write Exclusive persistent reservation type is not supported.
EX_AC_AR	The library returns a value of 0, indicating the Exclusive Access-All Registrants persistent reservation type is not supported.

Persistent Reserve Out

The Persistent Reserve Out (5Fh) command reserves a target for the exclusive or shared use of an initiator.

TABLE 6-64 Persistent Reserve Out Command

Byte	Bit							
	7	6	5	4	3	2	1	0
0	Operation Code (5Fh)							
1	Ignored			Service Action				
2	Scope				Type			
3	Reserved (00h)							
4	Reserved (00h)							
5 to 8	(MSB) Parameter List Length (18h)							(LSB)
9	Control (00h)							

Persistent Reserve Out Command Definitions:

Service Action	<p>This value indicates the action that will result from the Persistent Reservation Command:</p> <ul style="list-style-type: none"> ■ 00h = Register: Register or Unregister a reservation key with the library without generating a reservation. ■ 01h = Reserve: Create a persistent reservation of the scope and type specified in Byte 2. ■ 02h = Release: Remove an active persistent reservation. ■ 03h = Clear: Clear all persistent reservations for all initiators and reset all reservation keys to 0, if the requesting initiator is registered. ■ 04h = Preempt: Remove all reservations and registrations for the initiators associated with the service action reservation key in the parameter list. ■ 05h = Preempt and Abort: Perform a Preempt action and, additionally, clear the task set for all initiators associated with the service action reservation key. Also, clear any CAP locks and contingent allegiance in effect for these initiators. ■ 06h = Register and Ignore Existing Key: Register a reservation key with the library
Scope	<p>The value in the Scope field indicates whether a persistent reservation applies to an entire logical unit or to an element. The only valid value is 0h. 0h = The persistent reservation applies to the logical unit</p>
Type	<p>This value specifies the characteristics of the persistent reservation. Valid values are 3h and 6h.</p> <ul style="list-style-type: none"> ■ 3h = Exclusive Access: This value indicates that the initiator holding the persistent reservation has exclusive access. Some commands (for example, Move Medium) are only allowed for the persistent reservation holder. ■ 6h = Exclusive Access, Registrants Only: This value indicates that any registered initiator has exclusive access. Some commands (for example, Move Medium) are only allowed for registered I_T nexuses.
Parameter List Length	<p>This value should always specify a field length of 18h (24d) bytes. The parameter data for the Persistent Reserve Out command includes all fields, even when a field is not required for the specified service action.</p>

The parameter list for the Persistent Reserve Out command has this format:

TABLE 6-65 Persistent Reserve Out Parameter List

Byte	Bit							
	7	6	5	4	3	2	1	0
0 to 7	(MSB) Reservation Key (LSB)							
8 to 15	(MSB) Service Action Reservation Key (LSB)							
16 to 19	(MSB) Obsolete (LSB)							
20	Reserved (0h)				SPEC-I-PT (0)	ALL-TGT-PT (0)	Rsvd (0)	APTPL (0)
21	Reserved (00h)							
22 to 23	Obsolete (00h)							

Persistent Reserve Out Parameter List Definitions:

Reservation Key	This field contains an eight-byte value that identifies the initiator.
Service Action Reservation Key	This field contains information needed for four service actions: Register, Register and Ignore Existing Key, Preempt, and Preempt AND abort. See TABLE 6-67 for definitions of these actions.
SPEC_I_PT	The Specify Initiator Ports bit is not supported and must be set to 0.
ALL-TG-PT	The All Target Ports bit is not supported and must be set to 0.
APTPL	The Activate Persist Through Power Loss bit is not supported and must be set to 0.

TABLE 6-66 summarizes which fields are set by the application client and interpreted by the library for each service action and scope value.

TABLE 6-66 Persistent Reserve Out Service Actions and Valid Parameters

Service Action	Allowed Scope	Type	Reservation Key	Service Action Reservation Key	APTPL	ALL_TG_PT	SPEC_I_PT
REGISTER	ignored	ignored	valid	valid	valid	valid	valid
REGISTER AND IGNORE EXISTING KEYS	ignored	ignored	ignored	valid	valid	valid	valid
RESERVE	LU_SCOPE	valid	valid	ignored	ignored	ignored	ignored
RELEASE	LU_SCOPE	valid	valid	ignored	ignored	ignored	ignored
CLEAR	ignored	ignored	valid	ignored	ignored	ignored	ignored
PRE-EMPT	LU_SCOPE	valid	valid	valid	ignored	ignored	ignored
PRE-EMPT & ABORT	LU_SCOPE	valid	valid	valid	ignored	ignored	ignored

TABLE 6-67 Service Action Reservation Key Information

If the service action is...	Then the information in the field is...
Register	the new reservation key to be registered
Register and Ignore Existing Key	the new reservation key to be registered
Preempt	the reservation key of the persistent reservation being pre-empted
Preempt and Abort	the reservation key of the persistent reservation being pre-empted
See list of service action values on page on page 176 .	

Position to Element

The Position to Element command (2Bh) is supported only for compatibility with existing applications. It causes the hand to be positioned to the specified destination element address.

TABLE 6-68 Position to Element Command

Byte	Bit							
	7	6	5	4	3	2	1	0
0	Operation Code (2Bh)							
1	Ignored			Reserved (00h)				
2 to 3	(MSB)	Transport Element Address						(LSB)
4 to 5	(MSB)	Destination Element Address						(LSB)
6	Reserved (00h)							
7	Reserved (00h)							
8	Reserved (00h)							Invert (0)
9	Control Byte (00h)							

Position to Element Command Definitions:

Transport Element Address	This field defines the hand element to use and should contain the element address of the hand or 00h (0d). A value of 00h (0d) indicates use of the default hand.
Destination Element Address	This field defines the address of the element where the hand is to be positioned.
Invert	The library does not support this function and requires a value of 0.

Prevent/Allow Medium Removal

The Prevent/Allow Medium Removal command (1Eh) requests that the library enable or disable operator access to the cartridge access port (CAP).

- If allowed, the CAP may be unlocked and opened using the operator panel.
- If prevented, the CAP cannot be unlocked or opened.

This command is independent of device reservations if the Prevent bit is 0.

The library keeps Prevent/Allow data on a per-initiator basis.

- If any initiator has set a prevent state, the library prevents anyone from opening the CAP.
- If any initiator sends an Allow Media Command (Prevent bit set to 0), the library clears the prevent bit for all hosts and allows the operator to open the CAP.

During power-on and following a reset, all initiators are set to an allow state, which enables operator panel access to the CAP.

The Prevent/Allow Medium Removal command has no effect on the Pass- Thru-Port; it can only be used to affect access to the CAPs.

TABLE 6-69 Prevent/Allow Medium Removal Command

Byte	Bit							
	7	6	5	4	3	2	1	0
0	Operation Code (1Eh)							
1	Ignored			Reserved (00h)				
2	Reserved (00h)							
3	Reserved (00h)							
4	Reserved (00h)						Prevent	
5	Control Byte (00h)							

Prevent/Allow Medium Removal Command Definitions:

Prevent Bit	<p>The Prevent bit values are:</p> <ul style="list-style-type: none"> ■ 0 = The library allows operator panel access to unlock and open the indicated CAP. ■ 1 = The library prevents access to the indicated CAP.
--------------------	--

Read Element Status

The Read Element Status command (B8h) requests that the library return the status of the elements in the library.

TABLE 6-70 Read Element Status Command

Byte	Bit							
	7	6	5	4	3	2	1	0
0	Operation Code (B8h)							
1	Ignored			VolTag	Element Type Code			
2 to 3	(MSB)	Starting Element Address						(LSB)
4 to 5	(MSB)	Number of Elements						(LSB)
6	Reserved (00h)						CurData	DvcID
7 to 9	(MSB)	Allocation Length						(LSB)
10	Reserved (00h)							
11	Control Byte (00h)							

Read Element Status Command Definitions:

VolTag This bit indicates whether volume tag (VolTag) information is to be reported in response to this command:

- 0 = Volume Tag information is not reported
- 1 = Volume Tag information is reported.

Element Type Code This field specifies the particular element types selected for reporting:

- 0h = All Element Types reported
- 1h = Medium Transport Element (hand)
- 2h = Storage Element (cartridge tape storage cells)
- 3h = Import/Export Element (CAP cells and PTP cells)
- 4h = Data Transfer Element (tape drive)

For an Element Type Code of 0h, the element types are reported in ascending element address order, beginning with the first element greater than or equal to the Starting Element Address.

Starting Element Address This field specifies the minimum element address to report. Only elements with an element address greater than or equal to the Starting Element Address are reported. Element descriptor blocks are not generated for undefined element addresses. The Starting Element Address is set to a valid address for the library but does not have to be an address of the type requested in the Element Type Code.

Number of Elements	This field represents the maximum number of element descriptors to be transferred. This is an actual number of element descriptors to be transferred, not an element address range.
CurData	<p>The current data bit specifies that the library shall return element status data without causing device motion.</p> <ul style="list-style-type: none"> ■ 0 = Library operations are normal, and library mechanics may become active if needed to gather element static data. ■ 1 = The library is responding with data only; no mechanical operations are active <p>The CurData bit is effectively ignored by the library. The library will perform or not perform mechanical operations to obtain proper information at it's discretion independently of the setting of this bit.</p>
DvcID	<p>The device identification bit indicates whether the return data will contain device identification information.</p> <ul style="list-style-type: none"> ■ 0 = The library will not return device identification information. ■ 1 = The library will return device identification information only for data transfer elements.
Allocation Length	<p>This field specifies the length in bytes of the space allocated by the initiator for the transfer of element descriptors. Only complete element descriptors are transferred. Element descriptors are transferred until one of the following conditions is met:</p> <p>All available element descriptors of the type specified in the Element Type Code have been transferred, or</p> <p>The number of element descriptors specified in the Number of Elements field have been transferred, or</p> <p>There is less allocation length space available than required for the next complete element descriptor or header to be transferred.</p>

Read Element Status Data

The library returns data for a Read Element Status command with this structure:

- An eight-byte Element Status Data header, followed by
- One to four element pages, one page per element type.

A page consists of:

- An eight-byte Element Status Page header, followed by
- One or more Element Descriptors. The format of the descriptor is based on the element type reported in this page. Each element type receives a separate Element Descriptor format.

Data can be truncated based on the length specified in the allocation field.

Element Status Data Header Definition

The library sends this header once for each Read Element Status command.

TABLE 6-71 Element Status Data Header Definition

Byte	Bit							
	7	6	5	4	3	2	1	0
0 to 1	(MSB) First Element Address Reported (LSB)							
2 to 3	(MSB) Number of Elements Available (LSB)							
4	Reserved (00h)							
5 to 7	(MSB) Byte Count of Report Available (all pages, n-7) (LSB)							
8 to n	Element Status pages							

Element Status Data Header Definitions:

First Element Address Reported	This field indicates the lowest element address found of the type specified in the Element Type Codes and greater than or equal to the Starting Element Address.
Number of Elements Available	This field indicates the number of elements found of the type specified in the Element Type Codes and greater than or equal to the Starting Element Address. This number is adjusted to be less than or equal to the count specified in the Number of Elements field in the Read Element Status command.
Byte Count of Report Available	This field indicates the number of bytes of element status data available for all elements meeting the requirements of the Read Element Status command. This count does not include the Element Status Data header bytes. This value is not adjusted to match the allocation length from the command.

Element Status Page Header Definition

The library sends this header once for each type of element descriptors.

TABLE 6-72 Element Status Page Header

Byte	Bit							
	7	6	5	4	3	2	1	0
0	Reserved				Element Type Code			
1	PVolTag	AVolTag (0)	Reserved (0)					
2 to 3	(MSB) Element Descriptor Length							(LSB)
4	Reserved (00h)							
5 to 7	(MSB) Byte Count of Report Available (all pages, n-7)							(LSB)
8 to n	Element Descriptor(s)							

Element Status Page Header Definitions:

Element Type Code	This field indicates the specific element type being reported by this element descriptor page. The types are: <ul style="list-style-type: none"> ■ 01h = Medium Transport Element (hand) ■ 02h = Storage Element (cartridge tape storage cells) ■ 03h = Import/Export Element (CAP cells) ■ 04h = Data Transfer Element (tape drive)
PVolTag	This bit indicates if primary volume tag (PVolTag) information has been requested and is present. The possible values indicate: <ul style="list-style-type: none"> ■ 0 = Volume Tag information has not been requested. The data is omitted from the element descriptors. ■ 1 = Volume Tag information has been requested to be reported and is present.
AVolTag	The library does not support alternative volume tags (AVolTag) and returns a value of 0.
Element Descriptor Length	This field indicates the total number of bytes contained in a single element descriptor.
Byte Count of Descriptor Data Available	This field indicates the total number of bytes of element descriptor data available for the elements of this element type that meet the requirements of the Read Element Status command. This count does not include the Element Status Page header bytes. This value is not adjusted to match the allocation length.
Element Descriptors	<p>The following sections contain the field definitions for the four types of library elements, which are:</p> <ul style="list-style-type: none"> ■ Medium Transport Element (the hand) ■ Storage Element (cartridge tape storage cells) ■ Import/Export Element (CAP cells and PTP cells) ■ Data Transfer Element (tape drives) <p>Each element descriptor includes the element address and status flags. Each element descriptor might also contain sense key information as well as other information, depending on the element type.</p> <p>The element descriptors for the four types of elements are similar, with the exception of a few fields. Note: The differences in Bytes 02, 06, and 07 for the four element descriptors.</p> <p>The library does not support alternate volume tags. This information is not included in any of the element descriptors.</p>

Medium Transport Element Descriptor Definition

Medium transport elements are robotic components capable of physically moving cartridges. The Medium Transport Element Descriptor defines the robot characteristics.

TABLE 6-73 Medium Transport Element Descriptor

Byte	Bit							
	7	6	5	4	3	2	1	0
0 to 1	(MSB) Element Address (LSB)							
2	Reserved (00h)					Except	Rsvd (0)	Full
3	Reserved (00h)							
4	Additional Sense Code							
5	Additional Sense Code Qualifier							
6	Reserved (00h)							
7	Reserved (00h)							
8	Reserved (00h)							
9	SValid	Invert (0)	Reserved (00h)		ED	Medium Type		
10 to 11	(MSB) Source Storage Element Address (LSB)							
12 to 47	Primary Volume Tag Information Field omitted if PVolTag=0							
48	Reserved (0h)				Code Set (0)			
49	Reserved (0h)				Identifier Type (0)			
50	Reserved (00h)							
51	Identifier Length (0)							
52	Media Domain Field moved up if Primary Volume Tag Information is omitted.							
53	Media Type Field moved up if Primary Volume Tag Information is omitted.							
54 to 55	Reserved (00h) Field moved up if Primary Volume Tag Information is omitted.							

Medium Transport Element Descriptor Definitions:

Element Address	This field contains the element address of the robot.
Except	This bit indicates the current operational state of the robot: <ul style="list-style-type: none"> ■ 0 = The hand is operational. ■ 1 = The hand is in an abnormal state. The Additional Sense Code (ASC) and the Additional Sense Code Qualifier (ASCQ) fields contain information regarding the abnormal state. Other fields in the descriptor might be invalid and should be ignored.
Full	This bit indicates if the hand contains a cartridge tape: <ul style="list-style-type: none"> ■ 0 = The hand does not contain a cartridge tape. ■ 1 = The hand contains a cartridge tape. An initiator would see a cartridge in the hand during a Read Element Status only in the case of an anomaly.
Additional Sense Code	This field is valid only if the Except bit is set. In the case of an exception, it contains an ASC as defined for Request Sense data.
Additional Sense Code Qualifier	This field is valid only if the Except bit is set. In the case of an exception, it contains an ASCQ as defined for Request Sense data.
SValid	This bit indicates if the Source Element Address and Invert fields are valid: <ul style="list-style-type: none"> ■ 0 = The Source Element Address and Invert fields are not valid. ■ 1 = The Source Element Address and Invert fields are valid.
Invert	The library does not support multi-sided media and returns a value of 0.
ED	<ul style="list-style-type: none"> ■ 0 = The element is enabled (for example a magazine or drive has been installed or has been logically enabled) ■ 1 = The element is disabled
Medium Type	This field provides the type of medium currently present in the element as determined by the medium changer. The library returns the following values: <ul style="list-style-type: none"> ■ 0h = Unspecified - the medium changer cannot determine the medium type. ■ 1h = Data Medium ■ 2h = Cleaning Medium
Source Storage Element Address	This field is valid only if the SValid field is 1. This field contains the address of the last element from which the data cartridge was moved.
Primary Volume Tag Information	When the PVolTag bit is set to 1, the library returns volume tag information. When PVolTag is set to 0, this field is omitted, and the reserved fields below it are moved up. The library volume tag information includes six bytes of left-justified ASCII data that represents volume/serial number data from the cartridge tape. The field is padded to 32 bytes with 26 ASCII spaces. If the label on the cartridge tape is not readable, these 32 bytes will be set to 0. The last four bytes of the Volume Tag Information typically consist of two reserved bytes and two volume sequence bytes. The library does not support sequence numbers. These four bytes are set to 0.
Code Set	This field specifies the code set used for the identifier field and is set to 0 (not supported) for the Medium Transport Element Descriptor: 0h = Reserved

Identifier Type	The Identifier Type field indicates the format and assignment authority for the identifier and is set to 0 (not supported) for the Medium Transport Element Descriptor: 0h = Vendor Specific
Identifier Length	This field indicates the length of the Identifier field and is set to 0 (not supported) for the Medium Transport Element Descriptor. Note: That the combined length of the identifier field and the Identifier Pad is 32 bytes.
Media Domain	<p>The Media Domain field along with the Media Type field provides a hierarchy of information that indicates the type of media in the element:</p> <ul style="list-style-type: none"> ■ 01h or 53h = The element contains a DLT form factor cartridge. ■ 43h = The element contains an LTO (or future) cleaning form factor cartridge (43h is 'C'). ■ 4Ch = The element contains an LTO form factor cartridge (4Ch is 'L'). ■ FFh = The media domain cannot be determined. <p>This field is not valid if the Full bit is not set.</p>
Media Type	<p>The Media Type field along with the Media Domain field provides a hierarchy of information that indicates the type of media in the element.</p> <p>If the Media Domain field is 01h, the value reported for the Media Type field identifies in ASCII the type of DLT cartridge:</p> <ul style="list-style-type: none"> ■ S = The element contains an SDLT I cartridge. ■ 2 = The element contains an SDLT II cartridge. ■ 4 = The element contains a DLTtape S4 cartridge ■ FFh = The media type cannot be determined. <p>If the Media Domain field is 53h (53h is 'S'), the value reported for the Media Type field identifies in ASCII the type of DLT/SDLT cartridge:</p> <ul style="list-style-type: none"> ■ 1= The element contains an SDLT I cartridge. ■ 2 = The element contains an SDLT I cartridge. ■ 3 = The element contains an SDLT II cartridge. ■ 4 = The element contains a DLTtape S4 cartridge. ■ FFh = The media type cannot be determined. <p>If the Media Domain field is 43h (43h is 'C'), the value reported for the Media Type field identifies in ASCII the type of LTO cleaning cartridge:</p> <ul style="list-style-type: none"> ■ 1 = The element contains an HP Generation 1 LTO cleaning cartridge. ■ 2 = The element contains an IBM Generation 1 LTO cleaning cartridge. ■ 3 = The element contains a Quantum Generation 1 LTO cleaning cartridge. ■ U = The element contains a Universal LTO cleaning cartridge. ■ FFh = The media type cannot be determined. <p>This field is not valid if the Full bit is not set.</p> <p>If the Media Domain field is 4Ch (4Ch is 'L'), the value reported for the Media Type field identifies in ASCII the type of LTO cartridge:</p> <ul style="list-style-type: none"> ■ 1 = The element contains a 100 GB Generation 1 LTO cartridge. ■ 2 = The element contains a 200 GB Generation 2 LTO cartridge. ■ 3 = The element contains a 400 GB Generation 3 LTO cartridge ■ 4 = The element contains an 800 GB Generation 4 LTO cartridge ■ T = The element contains a 400 GB Generation 3 LTO WORM cartridge ■ U = The element contains an 800 GB Generation 4 LTO WORM cartridge ■ FFh = The media type cannot be determined <p>This field is not valid if the Full bit is not set.</p>

Storage Element Descriptor Definition

Storage elements are the main cartridge tape storage cells of the library. The Storage Element Descriptor describes a storage cell.

TABLE 6-74 Storage Element Descriptor

Byte	Bit							
	7	6	5	4	3	2	1	0
0 to 1	(MSB) Element Address (LSB)							
2	Reserved (00h)				Access (1)	Except	Rsvd (0)	Full
3	Reserved (00h)							
4	Additional Sense Code							
5	Additional Sense Code Qualifier							
6	Reserved (00h)							
7	Reserved (00h)							
8	Reserved (00h)							
9	SValid	Invert (0)	Reserved (00h)		ED	Medium Type		
10 to 11	(MSB) Source Storage Element Address (LSB)							
12 to 47	Primary Volume Tag Information (Field omitted if PVolTag=0)							
48	Reserved (0h)				Code Set (0)			
49	Reserved (0h)				Identifier Type (0)			
50	Reserved (00h)							
51	Identifier Length (0)							
52	Media Domain (Field moved up if Primary Volume Tag Information omitted.)							
53	Media Type (Field moved up if Primary Volume Tag Information omitted.)							
54 to 55	Reserved (00h, 00h) (Field moved up if Primary Volume Tag Information omitted.)							

Storage Element Descriptor Definitions:

Element Address	This field contains the element address of the storage element reported.
Access	This bit indicates access is allowed to the storage element by the hand. The library returns a value of 1.
Except	This bit indicates the operational state of the storage element: <ul style="list-style-type: none"> ■ 0 = The storage element is in a normal state. ■ 1 = The storage element is in an abnormal state, and the Additional Sense Code and the Additional Sense Code Qualifier fields contain information regarding the abnormal state. Other fields in the descriptor might be invalid, and should be ignored.
Full	This field indicates if the storage element contains a cartridge tape: <ul style="list-style-type: none"> ■ 0 = The storage element does not contain a cartridge tape. ■ 1 = The storage element does contain a cartridge tape.
Additional Sense Code	This field is valid only if the Except bit is set. In the case of an exception, it contains an ASC as defined for Request Sense data.
Additional Sense Code Qualifier	This field is valid only if the Except bit is set. In the case of an exception, it contains an ASCQ as defined for Request Sense data.
SValid	This bit indicates if the Source Element Address and Invert fields are valid: <ul style="list-style-type: none"> ■ 0 = The Source Element Address and Invert fields are not valid. ■ 1 = The Source Element Address and Invert fields are valid.
Invert	The library does not support multi-sided media and returns a value of 0.
ED	<ul style="list-style-type: none"> ■ 0 = The element is enabled (for example a magazine or drive has been installed or has been logically enabled) ■ 1 = The element is disabled
Medium Type	This field provides the type of medium currently present in the element as determined by the medium changer. The library returns the following values: <ul style="list-style-type: none"> ■ 0h = Unspecified - the medium changer cannot determine the medium type. ■ 1h = Data Medium ■ 2h = Cleaning Medium
Source Storage Element Address	This field is valid only if the SValid bit is 1. It contains the address of the last element from which the data cartridge was moved.
Primary Volume Tag Information	When the PVolTag bit is set to 1, the library returns Volume Tag Information. When PVolTag is set to 0, this field is omitted, and the reserved fields below it are moved up. The library Volume Tag Information includes six bytes of left-justified ASCII data, which represents volume/serial number data from the cartridge tape. The field is padded to 32 bytes with 26 ASCII spaces. If the label on the cartridge tape is not readable, these 32 bytes are set to 0. The last four bytes of the Volume Tag Information typically consist of two reserved bytes and 2 volume sequence bytes. The library does not support sequence numbers. These four bytes are set to 0.
Code Set	This field specifies the code set used for the identifier field and is set to 0 (not supported) for the Storage Element Descriptor: 0h = Reserved

Identifier Type	The Identifier Type field indicates the format and assignment authority for the identifier and is set to 0 (not supported) for the Storage Element Descriptor: 0h = Vendor Specific
Identifier Length	This field indicates the length of the Identifier field and is set to 0 (not supported) for the Storage Element Descriptor. Note: That the combined length of the identifier field and the Identifier Pad is 32 bytes.
Media Domain	<p>The Media Domain field along with the Media Type field provides a hierarchy of information that indicates the type of media in the element:</p> <ul style="list-style-type: none"> ■ 01h or 53h = The element contains a DLT form factor cartridge. ■ 43h = The element contains an LTO (or future) cleaning form factor cartridge (43h is 'C'). ■ 4Ch = The element contains an LTO form factor cartridge (4Ch is 'L'). ■ FFh = The media domain cannot be determined. <p>This field is not valid if the Full bit is not set.</p>
Media Type	<p>The Media Type field along with the Media Domain field provides a hierarchy of information that indicates the type of media in the element.</p> <p>If the Media Domain field is 01h, the value reported for the Media Type field identifies in ASCII the type of DLT/SDLT cartridge:</p> <ul style="list-style-type: none"> ■ S = The element contains an SDLT I cartridge. ■ 2 = The element contains an SDLT II cartridge. ■ 4 = The element contains a DLTtape S4 cartridge. ■ FFh = The media type cannot be determined. <p>If the Media Domain field is 53h (53h is 'S'), the value reported for the Media Type field identifies in ASCII the type of DLT/SDLT cartridge:</p> <ul style="list-style-type: none"> ■ 1 = The element contains an SDLT I cartridge. ■ 2 = The element contains an SDLT I cartridge. ■ 3 = The element contains an SDLT II cartridge. ■ 4 = The element contains a DLTtape S4 cartridge. ■ FFh = The media type cannot be determined <p>If the Media Domain field is 43h (43h is 'C'), the value reported for the Media Type field identifies in ASCII the type of LTO cleaning cartridge:</p> <ul style="list-style-type: none"> ■ 1 = The element contains an HP Generation 1 LTO cleaning cartridge. ■ 2 = The element contains an IBM Generation 1 LTO cleaning cartridge. ■ 3 = The element contains a Quantum Generation 1 LTO cleaning cartridge. ■ U = The element contains a Universal LTO cleaning cartridge. ■ FFh = The media type cannot be determined. <p>If the Media Domain field is 4Ch (4Ch is 'L'), the value reported for the Media Type field identifies in ASCII the type of LTO cartridge:</p> <ul style="list-style-type: none"> ■ 1 = The element contains a 100 GB Generation 1 LTO cartridge. ■ 2 = The element contains a 200 GB Generation 2 LTO cartridge. ■ 3 = The element contains a 400 GB Generation 3 LTO cartridge. ■ 4 = The element contains an 800 GB Generation 4 LTO cartridge ■ T = The element contains a 400 GB Generation 3 LTO WORM cartridge. ■ U = The element contains an 800 GB Generation 4 LTO WORM cartridge ■ FFh = The media type cannot be determined. <p>This field is not valid if the Full bit is not set.</p>

Import/Export Element Descriptor Definitions

Import/Export elements are the CAP and/or Pass-thru cells of the library. The Import/Export Element Descriptor describes a CAP cell.

TABLE 6-75 Import/Export Element Descriptor

Byte	Bit							
	7	6	5	4	3	2	1	0
0 to 1	(MSB) Element Address (LSB)							
2	OIR	CMC	InEnab (1)	ExEnab (1)	Access	Except	ImpExp	Full
3	Reserved (00h)							
4	Additional Sense Code							
5	Additional Sense Code Qualifier							
6	Reserved (00h)							
7	Reserved (00h)							
8	Reserved (00h)							
9	SValid	Invert (0)	Reserved (00h)		ED	Medium Type		
10 to 11	(MSB) Source Storage Element Address (LSB)							
12 to 47	Primary Volume Tag Information (Field omitted if PVolTag=0)							
48	Reserved (0h)				Code Set (0)			
49	Reserved (0h)				Identifier Type (0)			
50	Reserved (00h)							
51	Identifier Length (0)							
52	Media Domain (Field moved up if Primary Volume Tag Information omitted.)							
53	Media Type (Field moved up if Primary Volume Tag Information omitted.)							
54 to 55	Reserved (00h, 00h) (Field moved up if Primary Volume Tag Information omitted.)							

Import/Export Element Descriptor Definitions:

Element Address	This field contains the element address of the import/export element reported.
OIR	Operator Intervention Required bit <ul style="list-style-type: none"> ■ 0 = No operator intervention required to make the CAP accessible ■ 1 = Operator intervention required to make the CAP accessible
CMC	This bit is set to zero to indicate the import/export element is a CAP. A CMC bit of zero indicates that exports are to the operator's domain and imports are from the operator's domain. <ul style="list-style-type: none"> ■ Media shall not leave the domain of the media changer when prevented by the PREVENT ALLOW MEDIA REMOVAL command (see SPC).
InEnab	This bit indicates the import/export element supports the movement of cartridge tapes into the library. The library returns a value of 1.
ExEnab	This bit indicates that the import/export element supports the movement of cartridge tapes out of the library. The library returns a value of 1.
Access	This bit indicates whether access is allowed to the CAP element by the hand. <ul style="list-style-type: none"> ■ 0 = The CAP is open and cannot be accessed by the hand. Or the magazine at the requested Element Address has been removed. Thus the Full and Primary Volume Tag information cannot be determined, and should be ignored. More information about this condition is available through the Additional Sense Code and Additional Sense Code Qualifier fields. ■ 1 = The CAP is closed and accessible.
Except	This bit indicates the operational state of the import/export element: <ul style="list-style-type: none"> ■ 0 = The import/export element is in the normal state. ■ 1 = The import/export element is in an abnormal state, and the Additional Sense Code and the Additional Sense Code Qualifier fields contain information regarding the abnormal state. Other fields in this descriptor might be invalid, and should be ignored.
ImpExp	This bit indicates how the cartridge tape was placed in the element: <ul style="list-style-type: none"> ■ 0 = The cartridge tape in the import/export element was placed there by the library hand as part of an export operation. ■ 1 = The cartridge tape in the import/export element was placed there by an operator as part of an import operation.
Full	This bit indicates if the import/export element contains a cartridge tape: <ul style="list-style-type: none"> ■ 0 = The import/export element does not contain a cartridge tape. ■ 1 = The import/export element does contain a cartridge tape.
Additional Sense Code	This field is valid only if the Except bit is set. In the case of an exception, it contains an ASC as defined for Request Sense data.
Additional Sense Code Qualifier	This field is valid only if the Except bit is set. In the case of an exception, it contains an ASCQ as defined for Request Sense data.
SValid	This bit indicates if the Source Element Address and Invert fields are valid: <ul style="list-style-type: none"> ■ 0 = The Source Element Address and Invert fields are not valid. ■ 1 = The Source Element Address and Invert fields are valid.
Invert	The library does not support multi-sided media. The information reported is 0.

ED	<ul style="list-style-type: none"> ■ 0 = The element is enabled (for example a magazine or drive has been installed or has been logically enabled) ■ 1 = The element is disabled
Medium Type	<p>This field provides the type of medium currently present in the element as determined by the medium changer.</p> <p>The library returns the following values:</p> <ul style="list-style-type: none"> ■ 0h = Unspecified - the medium changer cannot determine the medium type. ■ 1h = Data Medium ■ 2h = Cleaning Medium
Source Storage Element Address	<p>This field is valid only if the SValid bit is 1. It contains the address of the last element from which the data cartridge was moved.</p>
Primary Volume Tag Information	<p>When the PVolTag bit is set to 1, the library returns Volume Tag Information. When PVolTag is set to 0, this field is omitted, and the reserved fields below it are moved up.</p> <p>The library Volume Tag Information includes 6 bytes of left-justified ASCII data which represents volume/serial number data read from the cartridge tape. The field is padded to 32 bytes with 26 ASCII spaces. If the label on the cartridge tape is not readable, these 32 bytes will be set to 0.</p> <p>The last four bytes of the Volume Tag Information consist of two reserved bytes and two-volume sequence bytes. The library does not support sequence numbers. These four bytes are set to 0.</p>
Code Set	<p>This field specifies the code set used for the identifier field and is set to 0 (not supported) for the Import/Export Element Descriptor</p> <p>0h = Reserved</p>
Identifier Type	<p>The Identifier Type field indicates the format and assignment authority for the identifier and is set to 0 (not supported) for the Import/Export Element Descriptor:</p> <p>0h = Vendor Specific</p>
Identifier Length	<p>This field indicates the length of the Identifier field and is set to 0 (not supported) for the Import/Export Element Descriptor.</p> <p>Note: That the combined length of the identifier field and the Identifier Pad is 32 bytes.</p>
Media Domain	<p>The Media Domain field along with the Media Type field provides a hierarchy of information that indicates the type of media in the element:</p> <ul style="list-style-type: none"> ■ 01h or 53h = The element contains a DLT form factor cartridge. ■ 43h = The element contains an LTO (or future) cleaning form factor cartridge (43h is 'C'). ■ 4Ch = The element contains an LTO form factor cartridge (4Ch is 'L'). ■ FFh = The media domain cannot be determined. <p>This field is not valid if the Full bit is not set.</p>

Media Type

The Media Type field along with the Media Domain field provides a hierarchy of information that indicates the type of media in the element.

If the Media Domain field is 01h, the value reported for the Media Type field identifies in ASCII the type of DLT cartridge:

- S = The element contains an SDLT I cartridge.
- 2 = The element contains an SDLT II cartridge.
- 4 = The element contains a DLTtape S4 cartridge.
- FFh = The media type cannot be determined.

If the Media Domain field is 53h (53h is 'S'), the value reported for the Media Type field identifies in ASCII the type of DLT/SDLT cartridge:

- 1 = The element contains an SDLT I cartridge.
- 2 = The element contains an SDLT I cartridge.
- 3 = The element contains an SDLT II cartridge.
- 4 = The element contains a DLTtape S4 cartridge
- FFh = The medium type cannot be determined.

If the Media Domain field is 43h (43h is 'C'), the value reported for the Media Type field identifies in ASCII the type of LTO cleaning cartridge:

- 1 = The element contains a HP Generation 1 LTO cleaning cartridge.
- 2 = The element contains an IBM Generation 1 LTO cleaning cartridge.
- 3 = The element contains a Quantum Generation 1 LTO cleaning cartridge.
- U = The element contains a Universal LTO cleaning cartridge.
- FFh = The media type cannot be determined.

This field is not valid if the Full bit is not set.

If the Media Domain field is 4Ch (4Ch is 'L'), the value reported for the Media Type field identifies in ASCII the type of LTO cartridge:

- 1 = The element contains a 100 GB Generation 1 LTO cartridge.
- 2 = The element contains a 200 GB Generation 2 LTO cartridge.
- 3 = The element contains a 400 GB Generation 3 LTO cartridge.
- 4 = The element contains an 800 GB Generation 4 LTO cartridge.
- T = The element contains a 400 GB Generation 3 LTO WORM cartridge.
- U = The element contains an 800 GB Generation 4 LTO WORM cartridge.
- FFh = The media type cannot be determined.

This field is not valid if the Full bit is not set.

Data Transfer Element Descriptor Definitions

Data transfer elements are the tape drives in the library. The Data Transfer Element Descriptor Definitions page describes a tape drive. The following table shows the data returned when the **DvcID bit in the command is set to 0**.

TABLE 6-76 Data Transfer Element Descriptor When DvcID = 0

Byte	Bit							
	7	6	5	4	3	2	1	0
0 to 1	(MSB) Element Address (LSB)							
2	Reserved (0h)				Access	Except	Rsvd (0)	Full
3	Reserved (00h)							
4	Additional Sense Code							
5	Additional Sense Code Qualifier							
6	Reserved (00h)							
7	Reserved (00h)							
8	Reserved (00h)							
9	SValid	Invert (0)	Reserved (00h)		ED	Medium Type		
10 to 11	(MSB) Source Storage Element Address (LSB)							
12 to 47	Primary Volume Tag Information (Field omitted if PVolTag = 0)							
48	Reserved (0h)				Code Set (0)			
49	Reserved (0h)				Identifier Type (0)			
50	Reserved (00h)							
51	Identifier Length (0)							
52	Media Domain (Field moved up if Primary Volume Tag information omitted.)							
53	Media Type (Field moved up if Primary Volume Tag information omitted.)							
54	Transport Domain (Field moved up if Primary Volume Tag information omitted.)							
55	Transport Type (Field moved up if Primary Volume Tag information omitted.)							
56 to 87	(MSB) Transport Serial Number (LSB)							

Data Transfer Element Descriptor When DvcID = 0 Definitions:

Element Address	This bit contains the element address of the data transfer element reported.
Access	This bit indicates access is allowed to the data transfer element by the hand: <ul style="list-style-type: none"> ■ 0 = Access is not allowed to the tape drive element by the hand. This will be the case when a cartridge tape is loaded and in use by the tape drive. The tape is set to ejected before it becomes accessible. ■ 1 = The tape drive is accessible.
Except	This bit indicates the operational state of the data transfer element: <ul style="list-style-type: none"> ■ 0 = The data transfer element is in the normal state. ■ 1 = The data transfer element is in an abnormal state, and the Additional Sense Code and the Additional Sense Code Qualifier fields contain information regarding the abnormal state. Other fields in this descriptor might be invalid, and should be ignored.
Full	This bit indicates if the data transfer element contains a cartridge tape: <ul style="list-style-type: none"> ■ 0 = The data transfer element does not contain a cartridge tape. ■ 1 = The data transfer element does contain a cartridge tape.
Additional Sense Code	This field is valid only if the Except bit is set. In the case of an exception, it contains an ASC as defined for Request Sense data.
Additional Sense Code Qualifier	This field is valid only if the Except bit is set. In the case of an exception, it contains an ASCQ as defined for Request Sense data.
SValid	This bit indicates if the Source Element Address and Invert fields are valid: <ul style="list-style-type: none"> ■ 0 = The Source Element Address and Invert fields are not valid. ■ 1 = The Source Element Address and Invert fields are valid.
Invert	The library does not support multi-sided media and returns a value of 0.
ED	<ul style="list-style-type: none"> ■ 0 = The element is enabled (for example a magazine or drive has been installed or has been logically enabled) ■ 1 = The element is disabled
Medium Type	This field provides the type of medium currently present in the element as determined by the medium changer. The library returns the following values: <ul style="list-style-type: none"> ■ 0h = Unspecified - the medium changer cannot determine the medium type. ■ 1h = Data Medium ■ 2h = Cleaning Medium
Source Storage Element Address	This field is valid only if the SValid bit is 1. It contains the address of the last element from which the data cartridge was moved.
Primary Volume Tag Information	<p>When the PVolTag bit is set to 1, the library returns Volume Tag Information. When PVolTag is set to 0, this field is omitted, and the reserved fields below it are moved up.</p> <p>The library Volume Tag Information includes 6 bytes of left-justified ASCII data which represents volume/serial number data read from the cartridge tape. The field is padded to 32 bytes with 26 ASCII spaces. If the label on the cartridge tape is not readable, these 32 bytes will be set to 0.</p> <p>The last four bytes of the Volume Tag Information have two reserved bytes and two volume sequence bytes. The library does not support sequence numbers. These four bytes are set to 0.</p>

Code Set	This field specifies the code set used for the identifier field and is set to 0 (not supported) for the Data Transfer Element Descriptor (DvcID = 0): 0h = Reserved
Identifier Type	The Identifier Type field indicates the format and assignment authority for the identifier and is set to 0 (not supported) for the Data Transfer Element Descriptor (DvcID = 0): 0h = Vendor Specific
Identifier Length	This field indicates the length of the Identifier field and is set to 0 (not supported) for the Data Transfer Element Descriptor (DvcID = 0) Note: That the combined length of the identifier field and the Identifier Pad is 32 bytes.
Media Domain	The Media Domain field along with the Media Type field provides a hierarchy of information that indicates the type of media in the element: <ul style="list-style-type: none"> ■ 01h or 53h = The element contains a DLT form factor cartridge. ■ 43h = The element contains an LTO (or future) cleaning form factor cartridge (43h is 'C'). ■ 4Ch = The element contains an LTO form factor cartridge (4Ch is 'L'). ■ FFh = The media domain cannot be determined. This field is not valid if the Full bit is not set.
Media Type	The Media Type field along with the Media Domain field provides a hierarchy of information that indicates the type of media in the element. If the Media Domain field is 01h, the value reported for the Media Type field identifies in ASCII the type of DLT cartridge: <ul style="list-style-type: none"> ■ S = The element contains an SDLT I cartridge. ■ 2 = The element contains an SDLT II cartridge. ■ 4 = The element contains a DLTtape S4 cartridge. ■ FFh = The media type cannot be determined. <ul style="list-style-type: none"> ■ If the Media Domain field is 53h (53h is 'S'), the value reported for the Media Type field identifies in ASCII the type of DLT/SDLT cartridge: <ul style="list-style-type: none"> ■ 1 = The element contains an SDLT I cartridge. ■ 2 = The element contains an SDLT I cartridge. ■ 3 = The element contains an SDLT II cartridge. ■ 4 = The element contains a DLTtape S4 cartridge. ■ FFh = The media type cannot be determined. If the Media Domain field is 43h (43h is 'C'), the value reported for the Media Type field identifies in ASCII the type of LTO cleaning cartridge: <ul style="list-style-type: none"> ■ 1 = The element contains a HP Generation 1 LTO cleaning cartridge. ■ 2 = The element contains an IBM Generation 1 LTO cleaning cartridge. ■ 3 = The element contains a Quantum Generation 1 LTO cleaning cartridge. ■ U = The element contains a Universal LTO cleaning cartridge. ■ FFh = The media type cannot be determined. This field is not valid if the Full bit is not set.

Media Type (cont.)	<p>If the Media Domain field is 4Ch (4Ch is 'L'), the value reported for the Media Type field identifies in ASCII the type of LTO cartridge:</p> <ul style="list-style-type: none"> ■ 1 = The element contains a 100 GB Generation 1 LTO cartridge. ■ 2 = The element contains a 200 GB Generation 2 LTO cartridge. ■ 3 = The element contains a 400 GB Generation 3 LTO cartridge. ■ 4 = The element contains an 800 GB Generation 4 LTO cartridge. ■ T = The element contains a 400 GB Generation 3 LTO WORM cartridge. ■ U = The element contains an 800 GB Generation 4 LTO WORM cartridge. ■ FFh = The media type cannot be determined. <p>This field is not valid if the Full bit is not set.</p>
Transport Domain	<p>The Transport Domain field with the Transport Type field provide a hierarchy of information that indicates the type of data transfer element installed:</p> <ul style="list-style-type: none"> ■ 01h = The transport supports DLT/SDLT form factor cartridges. ■ 4Ch = The transport supports LTO form factor cartridges (4Ch is 'L'). ■ FFh = The transport domain cannot be determined.
Transport Type	<p>If the Transport Domain field is 01h, the value in the Transport Type field indicates that the drive installed is:</p> <ul style="list-style-type: none"> ■ 15h = A Quantum SDLT 320 drive ■ 17h = A Quantum SDLT 600 drive ■ 18h = A Quantum DLT S4 drive ■ FFh = The type cannot be determined. <p>If the Transport Domain field is 4Ch (4Ch is 'L'), the value in the Transport Type field indicates that the drive installed is:</p> <ul style="list-style-type: none"> ■ 33h = An HP Generation 2 LTO drive ■ 34h = An IBM Generation 2 LTO drive ■ 35h = A Quantum Generation 2 LTO drive ■ 36h = An HP Generation 3 LTO drive. ■ 37h = An IBM Generation 3 LTO drive. ■ 38h = A Quantum Generation 3 LTO drive. ■ 39h = An HP Generation 4 LTO drive. ■ 3Ah = An IBM Generation 4 LTO drive ■ FFh = The type cannot be determined.
Transport Serial Number	<p>Thirty-two ASCII characters represent the unique transport serial number.</p> <p>For tape drives with less than 32 bytes of ASCII serial number data, the value is left-justified and the unused LSB bytes contain ASCII blanks.</p> <p>If the serial number is not available from a tape drive that should support an ASCII serial number, ASCII blanks are returned.</p> <p>Left justification in this 32-byte field provides space for serial numbers of varying lengths.</p>

Data Transfer Element Descriptor Definitions

Data transfer elements are the tape drives in the library. The Data Transfer Element Descriptor Definitions page describes a tape drive. The following table shows the data returned when the **DvcID bit in the command is set to 1**.

TABLE 6-77 Data Transfer Element Descriptor When DvcID = 1

Byte	Bit							
	7	6	5	4	3	2	1	0
0 to 1	(MSB) Element Address (LSB)							
2	Reserved (0)			Access	Except	Rsvd (0)	Full	
3	Reserved (00h)							
4	Additional Sense Code							
5	Additional Sense Code Qualifier							
6	Reserved (00h)							
7	Reserved (00h)							
8	Reserved (00h)							
9	SValid	Invert (0)	Reserved (00h)		ED	Medium Type		
10 to 11	(MSB) Source Storage Element Address (LSB)							
12 to 47	Primary Volume Tag Information (Field omitted if PVolTag = 0)							
48	Reserved (0h)				Code Set (2)			
49	Reserved (0h)				Identifier Type (0)			
50	Reserved (00h)							
51	Identifier Length (x)							
52 to 52+x-1 (x bytes)	Identifier							
32-x bytes	Identifier Pad							
84	Media Domain							
85	Media Type							
86	Transport Domain							
87	Transport Type							

Data Transfer Element Descriptor (DvcID = 1) Definitions:

Element Address	This bit contains the element address of the data transfer element reported.
Access	This bit indicates access is allowed to the data transfer element by the hand: <ul style="list-style-type: none"> ■ 0 = Access is not allowed to the tape drive element by the hand. This will be the case when a cartridge tape is loaded and in use by the tape drive. The tape must be ejected before it becomes accessible. ■ 1 = The tape drive is accessible.
Except	This bit indicates the operational state of the data transfer element: <ul style="list-style-type: none"> ■ 0 = The data transfer element is in the normal state. ■ 1 = The data transfer element is in an abnormal state, and the Additional Sense Code and the Additional Sense Code Qualifier fields contain information regarding the abnormal state. Other fields in this descriptor might be invalid, and should be ignored
Full	This bit indicates if the data transfer element contains a cartridge tape: <ul style="list-style-type: none"> ■ 0 = The data transfer element does not contain a cartridge tape. ■ 1 = The data transfer element does contain a cartridge tape.
Additional Sense Code	This field is valid only if the Except bit is set. In the case of an exception, it contains an ASC as defined for Request Sense data.
Additional Sense Code Qualifier	This field is valid only if the Except bit is set. In the case of an exception, it contains an ASCQ as defined for Request Sense data.
SValid	This bit indicates if the Source Element Address and Invert fields are valid: <ul style="list-style-type: none"> ■ 0 = The Source Element Address and Invert fields are not valid. ■ 1 = The Source Element Address and Invert fields are valid.
Invert	The library does not support multi-sided media and returns a value of 0.
ED	<ul style="list-style-type: none"> ■ 0 = The element is enabled (for example a magazine or drive has been installed or has been logically enabled) ■ 1 = The element is disabled
Medium Type	This field provides the type of medium currently present in the element as determined by the medium changer. The library returns the following values: <ul style="list-style-type: none"> ■ 0h = Unspecified - the medium changer cannot determine the medium type. ■ 1h = Data Medium ■ 2h = Cleaning Medium
Source Storage Element Address	This field is valid only if the SValid bit is 1. It contains the address of the last element from which the data cartridge was moved.
Primary Volume Tag Information	When the PVolTag bit is set to 1, the library returns Volume Tag Information. When PVolTag is set to 0, this field is omitted, and the reserved fields below it are moved up. The library Volume Tag Information includes 6 bytes of left-justified ASCII data which represents volume/serial number data read from the cartridge tape. The field is padded to 32 bytes with 26 ASCII spaces. If the label on the cartridge tape is not readable, these 32 bytes will be set to 0. The last four bytes of the Volume Tag Information have two reserved bytes and two volume sequence bytes. The library does not support sequence numbers. These four bytes are set to 0.
Code Set	This field specifies the code set used for the identifier field: 2h = The identifier contains ASCII graphic codes (code values 20h through 7Eh).

Identifier Type	<p>The Identifier Type field indicates the format and assignment authority for the identifier:</p> <p>0h = No assignment authority was used, and consequently there is no guarantee that the identifier is globally unique. In other words, the identifier is vendor specific.</p>
Identifier Length	<p>This field indicates the length of the Identifier field. Note: That the combined length of the Identifier field and the Identifier Pad is 32 bytes.</p>
Identifier	<p>This field contains the device identification of the type indicated in the Identifier Type field and in the format specified in the Code Set field.</p>
Identifier Pad	<p>This field contains binary zeros if the identifier is binary. This field contains ASCII blanks if the identifier is ASCII. The number of zeros or blanks depends on the length of the Identifier field. Note: That the combined length of the Identifier field and the Identifier Pad is 32 bytes.</p>
Media Domain	<p>The Media Domain field along with the Media Type field provides a hierarchy of information that indicates the type of media in the element:</p> <ul style="list-style-type: none"> ■ 01h or 53h = The element contains a DLT form factor cartridge. ■ 43h = The element contains an LTO (or future) cleaning form factor cartridge (43h is 'C'). ■ 4Ch = The element contains an LTO form factor cartridge (4Ch is 'L'). ■ FFh = The media domain cannot be determined. <p>This field is not valid if the Full bit is not set</p>
Media Type	<p>The Media Type field, along with the Media Domain field, provides a hierarchy of information that indicates the type of media in the element.</p> <p>If the Media Domain field is 01h, the value reported for the Media Type field identifies in ASCII the type of DLT/SDLT cartridge:</p> <ul style="list-style-type: none"> ■ S = The element contains an SDLT I cartridge. ■ 2 = The element contains an SDLT II cartridge. ■ 4 = The element contains a DLTtape S4 cartridge ■ FFh = The media type cannot be determined. <p>If the Media Domain field is 53h (53h is 'S'), the value reported for the Media Type field identifies in ASCII the type of DLT/SDLT cartridge:</p> <ul style="list-style-type: none"> ■ 1 = The element contains an SDLT I cartridge. ■ 2 = The element contains an SDLT I cartridge. ■ 3 = The element contains an SDLT II cartridge. ■ 4 = The element contains a DLTtape S4 cartridge. ■ FFh = The media type cannot be determined. <p>If the Media Domain field is 43h (43h is 'C'), the value reported for the Media Type field identifies in ASCII the type of LTO cleaning cartridge:</p> <ul style="list-style-type: none"> ■ 1 = The element contains an HP Generation 1 LTO cleaning cartridge. ■ 2 = The element contains an IBM Generation 1 LTO cleaning cartridge. ■ 3 = The element contains a Quantum Generation 1 LTO cleaning cartridge. ■ U = The element contains a Universal LTO cleaning cartridge. ■ FFh = The media type cannot be determined. <p>This field is not valid if the Full bit is not set.</p>

Media Type (cont.)	If the Media Domain field is 4Ch (4Ch is 'L'), the value reported for the Media Type field identifies in ASCII the type of LTO cartridge: <ul style="list-style-type: none">■ 1 = The element contains a 100 GB Generation 1 LTO cartridge.■ 2 = The element contains a 200 GB Generation 2 LTO cartridge.■ 3 = The element contains a 400 GB Generation 3 LTO cartridge.■ 4 = The element contains an 800 GB Generation 4 LTO cartridge.■ T = The element contains a 400 GB Generation 3 LTO WORM cartridge.■ U = The element contains an 800 GB Generation 4 LTO WORM cartridge.■ FFh = The media type cannot be determined. This field is not valid if the Full bit is not set.
Transport Domain	The Transport Domain field with the Transport Type field provide a hierarchy of information that indicates the type of data transfer element installed: <ul style="list-style-type: none">■ 01h = The transport supports DLT/SDLT form factor cartridges.■ 4Ch = The transport supports LTO form factor cartridges (4Ch is 'L').■ FFh = The transport domain cannot be determined.
Transport Type	If the Transport Domain field is 01h, the value in the Transport Type field indicates that the drive installed is: <ul style="list-style-type: none">■ 15h = A Quantum SDLT 320 drive■ 17h = A Quantum SDLT 600 drive■ 18h = A Quantum DLT S4 drive■ FFh = The type cannot be determined If the Transport Domain field is 4Ch (4Ch is 'L'), the value in the Transport Type field indicates that the drive installed is: <ul style="list-style-type: none">■ 33h = An HP Generation 2 LTO drive■ 34h = An IBM Generation 2 LTO drive■ 35h = A Quantum Generation 2 LTO drive■ 36h = An HP Generation 3 LTO drive.■ 37h = An IBM Generation 3 LTO drive.■ 38h = A Quantum Generation 3 LTO drive.■ 39h = An HP Generation 4 LTO drive.■ 3Ah = An IBM Generation 4 LTO drive■ FFh = The type cannot be determined

Release (6)

The 6-byte Release command (17h) enables the initiator to release unit or element reservations of the library as set using a previous Reserve command.

Performing a unit release of a library that has no active reservations is not considered an error. Only the initiator that performed the reservation can release the reservation. If another initiator attempts to release a unit reservation, the library returns good status, but does not release the reservation.

TABLE 6-78 Release Command (6)

Byte	Bit							
	7	6	5	4	3	2	1	0
0	Operation Code (17h)							
1	Ignored			Reserved (0h)				Element
2	Reservation Identification							
3	Reserved (00h)							
4	Reserved (00h)							
5	Control Byte (00h)							

Release Element Definitions:

Element	<p>This bit indicates if the release is an element release:</p> <ul style="list-style-type: none"> ■ 0 = The library or any elements reserved by the initiator are to be released from reserved status. ■ 1 = The reserved elements associated with the Reservation Identification field from this initiator are to be released from reserved status.
Reservation Identification	<p>This field is a value established by the initiator in a previous Reserve command.</p> <p>The field identifies the specific element reservation to be released.</p> <p>If an invalid Reservation Identification is specified, the library returns a Check Condition status. If the Element bit is 0, ignore this field.</p>

Release (10)

The 10-byte Release command (57h) enables the initiator to release unit reservations of the library as set using a previous Reserve command and optionally to perform a release for a third party initiator.

Performing a unit release of a library that has no active reservations is not considered an error. Only the initiator that performed the reservation or the third party for which the reservation was made can release the reservation. If another initiator attempts to release a unit reservation, the library returns good status, but does not release the reservation.

TABLE 6-79 Release (10) Command

Byte	Bit							
	7	6	5	4	3	2	1	0
0	Operation Code (57h)							
1	Ignored			3rdpty	Reserved (0h)		LongID (0)	Obsolete
2	Reserved (00h)							
3	Third Party Device Id							
4-6	Reserved (00h)							
7 to 8	(MSB)	Parameter List Length						(LSB)
9	Control Byte (00h)							

Release (10) Command Definitions:

3rdpty	This field indicates whether the reservation is on behalf of a third party or not. <ul style="list-style-type: none"> ■ 0 = The reservation is on behalf of the calling requester. ■ 1 = The reservation is on behalf of a specified Third party Device Id.
LongID	The LongID field indicates whether device IDs greater than 255 are required. The library only accepts a value of 0. LongIDs are not supported.
Third Party Device ID	The ID of the third Party device.
Parameter List Length	This field indicates the length in bytes of the Parameter List that follows the command. Ignore this field if the Element bit is not set.

Report LUNS

The Report LUNS command (A0h) returns to the initiator the known LUNs to which the initiator can send commands.

TABLE 6-80 Report LUNs Command

Byte	Bit							
	7	6	5	4	3	2	1	0
0	Operation Code (A0h)							
1	Ignored			Reserved (0h)				
2	Select Report							
3 to 5	Reserved (0h)							
6 to 9	(MSB)	Allocation Length						(LSB)
10	Reserved (00h)							
11	Control Byte (00h)							

Report LUNs command Definitions:

Select Report This field specifies the type of logical unit addresses that shall be reported.

- 00h = LUN addresses reported shall be limited to the following addressing:
 - LUN addressing method;
 - Peripheral device addressing method; and
 - Flat space addressing method.
- 02h = All LUNS accessible to the initiator for this port are accessible

Allocation Length This field specifies the number of bytes that the initiator has allocated for data to be returned from the Report LUNs command. The Allocation must be at least 16 bytes. If it is less, a check condition is returned with the sense key set to illegal request and the additional sense data set to invalid field in the command descriptor block (CDB).

Report LUNs Data Definition

The library returns the following data for the Report LUNs command.

TABLE 6-81 Report LUNs Data

Byte	Bit							
	7	6	5	4	3	2	1	0
0 to 3	(MSB) LUN list length							(LSB)
4 to 7	Reserved (0)							
8 to 15	(MSB) First LUN Descriptor							(LSB)
n -7 to n	(MSB) Last LUN Descriptor (n)							(LSB)

Report LUNs Data Definitions:

LUN list length	The library returns the length in bytes of the LUN list that is available for transfer. It is equal to 8 times the number of available logical units for the initiator. For example: If the allocation length is 16 bytes and 2 logical units are available, this command will return the 8-byte header and 1 logical unit descriptor; however, the LUN list length will still be 16 because 16 bytes were available if the allocation length was sufficient.
------------------------	--

TABLE 6-82 LUN Descriptor

Byte	Bit							
	7	6	5	4	3	2	1	0
0	Address Method		Bus ID (0h)					
1	Single Level LUN Address							
2 to 3	Second Level LUN Address (00h)							
4 to 5	Third Level LUN Address (00h)							
6 to 7	Fourth Level LUN Address (00h)							

LUN Descriptor Data:

Address Method	This is set to 0h indicating single level LUN addressing is used.
Bus ID	This is set to 0h indicating a logical unit at the current level.
Single Level LUN Address	This is the value of the LUN
Second, Third, and Fourth Level LUN Address	Set to 00h for single level addressing

Request Sense

The Request Sense command (03h) requests the library transfer sense data to the initiator.

Note – A reset or an abort message clears the contingent allegiance.

TABLE 6-83 Request Sense Command

Byte	Bit							
	7	6	5	4	3	2	1	0
0	Operation Code (03h)							
1	Ignored			Reserved (00h)				Desc (0h)
2	Reserved (00h)							
3	Reserved (00h)							
4	Allocation Length							
5	Control Byte (00h)							

Request Sense Command Definitions:

Desc	The Desc bit indicates which sense data format shall be returned. The library returns a value of 0, indicating fixed format sense data is returned.
Allocation Length	This field specifies the number of bytes that the initiator has allocated for returned sense data. The library provides a maximum of 14h (20d) bytes of sense data.

Sense Data

Sense data is available when:

- The previous command to the specified I_T_L nexus terminated with Check Condition status. Multiple errors might occur during the processing of a single SCSI command. The sense key reflects the first error that occurred.
- The previous command to the specified I_T_L nexus terminated with an unexpected bus free error. (Sense data might be available in this case, but not always.)
- The Request Sense command was issued to an unsupported LUN. In this case, the library does not return a check condition and returns sense data:
 - Sense Key set to Illegal Request (05h)
 - ASC set to Logical Unit Not Supported (25h)
 - ASCQ set to 00h

If no sense data is available for the specified I_T_L nexus, the library returns sense data:

- Sense Key set to No Sense (0h)
- ASC set to No Additional Sense Information (00h)
- ASCQ set to 00h

The library returns Check Condition status for a Request Sense command only to report errors specific to the command itself.

For example:

- A non-zero reserved bit is detected in the CDB.
- An unrecoverable parity error is detected on the data bus.

If a recovered error occurs during the execution of a Request Sense command, the library returns the sense data with Good status. If the library returns a Check Condition status for a Request Sense command, the sense data might be invalid.

For example:

- A non-zero reserved bit is detected in the CDB.
- An unrecoverable parity error is detected on the data bus.

If a recovered error occurs during the execution of a Request Sense command, the library returns the sense data with Good status. If the library returns a Check Condition status for a Request Sense command, the sense data might be invalid.

Request Sense Data Definitions

TABLE 6-84 shows the Request Sense Data Definitions.

TABLE 6-84 Request Sense Data

Byte	Bit							
	7	6	5	4	3	2	1	0
0	Valid (0)	Error Code (70h)						
1	Segment Number (00h)							
2	Reserved (0h)				Sense Key			
3 to 6	(MSB)	Information (00h)						(LSB)
7	Additional Sense Length (n-7)							
8 to 11	(MSB)	Command Specific Information (00h)						(LSB)
12	Additional Sense Code							
13	Additional Sense Code Qualifier							
14	Field Replaceable Unit Code (00h)							
15	SKSV	C/D	Reserved (0)		BPV (0)	Bit Pointer (0h)		
16 to 17	(MSB)	Field Pointer						(LSB)
18	Reserved (00h)							
19	Reserved (00h)							

Request Sense Data Definitions:

Valid	This bit indicates if the Information field contains valid data. The library does not return data in the Information field. The value is 0.
Error Code	This bit indicates if the error is current or deferred. The library returns only current errors. The value is 70h.
Segment Number	The library does not support segment numbers and returns a value of 00h.
Sense Key	The Sense Key (SK) field, with the Additional Sense Code and Additional Sense Code Qualifier fields, describes the error.
Information	The library does not support this field and returns a value of 00h.
Additional Sense Length	This field indicates the Additional Sense Length provided by the library excluding this byte. The typical value is 0Ch (12d).
Command Specific Information	The library does not support this field and returns a value of 00h.
Additional Sense Code	The Additional Sense Code (ASC) field, with the Sense Key and Additional Sense Code Qualifier fields, describes the error.
Additional Sense Code Qualifier	The Additional Sense Code Qualifier (ASCQ) field, with the Sense Key and Additional Sense Code fields, describes the error.
Field Replaceable Unit Code	The library does not support this field and returns a value of 00h.
SKSV (Sense Key Specific Valid)	When the Sense Key Specific Valid bit is set to 1, the fields C/D and Field pointer are valid. Otherwise, ignore these fields.
C/D (Command/Data)	Command/Data indicates whether the Check Condition status resulted from an illegal parameter in either the command descriptor block (Command) or the parameter list (Data) <ul style="list-style-type: none"> ■ 0 = Illegal parameter in the parameter list. ■ 1 = Illegal parameter in the command descriptor block.
BPV (Bit Pointer Valid)	The library does not support the Bit Pointer Valid (BPV) field and returns a value of 0.
Bit Pointer	The library does not support this field and returns a value of 0h.
Field Pointer	This field contains the number of the byte where the error occurred. Byte numbers start at 00. When a multiple-byte field is in error, the Field Pointer contains the value of the most significant byte of the field, which is the byte with the lowest byte number. For example, if a field consists of bytes 02, 03, and 04, the most significant byte is 02.

Sense Key

The Sense Key field provides basic information about an error.

[TABLE 6-85](#) lists the Sense Keys with an explanation for each code. The Sense Key field, with the Additional Sense Code and Additional Sense Code Qualifier fields, provides a description about the error.

See [“Additional Sense Codes and Qualifiers”](#) on page 212 for more information.

TABLE 6-85 Sense Key Code Descriptions

Code	Error	Description
0h	No Sense	Indicates there is no specific sense key information to be reported. A sense key of 0 indicates a successful command.
2h	Not Ready	Indicates the addressed logical unit is not ready for library motion commands (library is not initialized, device is not ready).
4h	Hardware Error	Indicates the device detected an unrecoverable hardware failure while performing the command or during a self-test.
5h	Illegal Request	Indicates an illegal parameter in the command descriptor block or in the parameter list data.
6h	Unit Attention	Indicates a power-on or reset has occurred to the device, or a not ready-to-ready transition has occurred, or an I/O element has been accessed. Also, this may indicate mode parameters have changed, or the microcode has been changed.
Bh	Aborted Command	Indicates the device aborted the command. The initiator might be able to recover by trying the command again.

Additional Sense Codes and Qualifiers

Bytes 12 and 13 of the sense data contain the Additional Sense Code (ASC) and Additional Sense Code Qualifier (ASCQ) fields. These codes provide additional device-specific information about the error or exception.

Each code contains a unique combination of the sense key, additional sense code, and additional sense code qualifier. The following pages describe the error codes for the library grouped by type of sense key.

No Sense Key

The library returns a No Sense Key (00h) when sense is requested, but no error has occurred. The ASC and ASCQ values are zero.

Not Ready Sense Key Codes

If a command is sent when the library is not ready, it generates a Not Ready error code. The following codes describe the conditions of the library that can generate Not Ready codes.

TABLE 6-86 Not Ready Sense Keys

Description	Sense Key	ASC	ASCQ
Not Ready, Cause Not Reportable	2h	04h	00h
Not Ready, In Process of Becoming Ready	2h	04h	01h
Not Ready, Manual Intervention Required	2h	04h	03h
Not Ready, Maintenance Mode	2h	04h	81h
Not Ready, Cartridge Access Port Open	2h	3Ah	02h
Not Ready, Cleaning Cartridge Installed	2h	30h	03h

Not Ready, Cause Not Reportable

The library detected a not ready state after execution of the command was started.

Not Ready, In Process of Becoming Ready

The library is initializing and performing an audit. Initialization occurs in a number of situations, including power-on, after the door has been opened then closed, as part of the Send Diagnostic command, when requested from the operator panel, and as part of a recovery during certain failures.

Not Ready, Manual Intervention Required

Manual intervention errors include: the front door is open, the CAP is open, the library is in maintenance mode, or the library is in an inoperable state.

- If the library front door is open, closing the door causes the library to reinitialize and go into a ready state.
- If the library is in an inoperable state, reinitialize the library using the operator panel.
- If the library is in maintenance mode, take the library out of this mode using the operator panel or CSE port.

Not Ready, Maintenance Mode

The library was placed in maintenance mode from the operator panel or CSE port.

Not Ready, Cartridge Access Port Open

The library detected that the CAP is open and a SCSI command was issued to access the CAP.

Not Ready, Cleaning Cartridge Installed

The library is performing an Auto Clean function on the data transfer element (tape drive) requested.

Note – While the cleaning cartridge remains in the drive, the library processes host commands normally. If a host requests a data mount to the drive being cleaned, then the library rejects the command and sends the Not Ready sense key (02), with ASC 30 and ASCQ 03 (Cleaning Cartridge Installed).

The host receives the data mount error for the duration of the cleaning time. Cleaning times vary, depending on the type of drive, the cleaning cartridge, robotic times, and potential retry operations. The time required to clean a 9840 is about 30 seconds. The time required to clean a DLT drive varies with the number of times the cleaning tape is used. The tape is good for 20 uses. Each time you use it takes longer than the last time because the operation goes farther on the tape cartridge. The longest cycle, cleaning cycle (20), takes approximately 5 minutes and 15 seconds.

Hardware Error Sense Key

The library generates a Hardware Error sense key if a hardware or firmware error is detected during command execution. The following pages describe the conditions that generate hardware errors.

TABLE 6-87 Hardware Error Sense Keys

Description	Sense Key	ASC	ASCQ
Hardware Error, General	4h	40h	01h
Hardware Error, Tape Drive	4h	40h	02h
Hardware Error, Cartridge Access Port	4h	40h	03h
Hardware Error, Imbedded Software	4h	44h	00h
Hardware Error/Media Load/Eject Failed	4h	53h	00h

Hardware Error, General

The library generates a general hardware error when it detects an internal electronics error during a command. This includes the electronics, vision system, and robotics of the library.

Hardware Error, Tape Drive

The library generates a tape-drive error when an operation to the drive fails. The problem could be the tape drive or the interface between the library and tape drive.

Hardware Error, CAP

The library generates a hardware error when the CAP fails.

Hardware Error, Embedded Software

The library generates a hardware error when an unexpected condition is detected by the embedded software that controls the SCSI interface. This error is used for arbitrary limitations of the embedded software.

Hardware Error, Media Load/Eject Failed

The library generates a hardware error when a load or eject fails to complete.

Illegal Request Sense Key

Any illegal parameters in a command descriptor block (CDB) or parameter list for a particular command generate an Illegal Request sense key (see [TABLE 6-88](#)).

In some cases, additional information is available in Byte 15 of the sense data, which includes the sense-key-specific-value (SKSV) and command/data (C/D) fields. This information indicates the byte in the command descriptor block or the parameter list, which is in error.

If available, the SKSV bit in the sense data is set to 1.
See [“Request Sense” on page 208](#) for more information.

TABLE 6-88 Illegal Request Sense Keys

Description	Sense Key	ASC	ASCQ	SKSV
Parameter Length Error	5h	1Ah	00h	Yes
Invalid Command	5h	20h	00h	Yes
Invalid Element	5h	21h	01h	No
Invalid Field in CDB	5h	24h	00h	Yes
Logical Unit Not Supported	5h	25h	00h	No
Invalid Field in Parameters	5h	26h	00h	Yes
Invalid Release of Persistent Reservation	5h	26h	04h	No
Incompatible Medium	5h	30h	00h	No
Saving Parameters Not Supported	5h	39h	00h	Yes
Medium Not Present, Drive Not Unloaded	5h	3Ah	00h	No
Medium Magazine Removed	5h	3Bh	12h	No
Destination Element Full	5h	3Bh	0Dh	No
Source Element Empty	5h	3Bh	0Eh	No
Magazine Removed	5h	3Bh	12h	No
Insufficient Resources	5h	55h	03h	No

Unit Attention Sense Key

The library generates a Unit Attention sense key for *all* initiators if the library needs to inform the host of an asynchronous event. The following pages describe library conditions that generate Unit Attention errors.

TABLE 6-89 Unit Attention Sense Keys

Description	Sense Key	ASC	ASCQ
Power-On Occurred	6h	29h	01h
SCSI Bus Reset	6h	29h	02h
Bus Device Reset Message	6h	29h	03h
LUN Reset	6h	29h	03h
Target Reset	6h	29h	03h
Not Ready-to-Ready Transition	6h	28h	00h
CAP Element Accessed	6h	28h	01h
Mode Parameters Changed	6h	2Ah	01h
Reservations Preempted	6h	2Ah	03h
Reservations Released	6h	2Ah	04h
Registrations Preempted	6h	2Ah	05h
Microcode Has Been Changed	6h	3Fh	01h
LUN Data Has Changed	6h	3Fh	0Eh

Power On

The library generates this type of Unit Attention when the library is powered-on, IPLed from the operator panel, or reset over the interface. A Unit Attention is generated for all initiators.

SCSI Bus Reset

The library generates this type of Unit Attention to all initiators after the SCSI bus is clear of all I/O processes following a hard reset.

Bus Device Reset Message

The library generates this message to all initiators after the library is clear of all I/O processes following a hard reset.

LUN Reset

The library generates this type of Unit Attention to all initiators after the library is clear of all I/O processes following the LUN reset.

Target Reset

The library generates this type of Unit Attention to all initiators after the library is clear of all I/O processes following the Target reset.

Not Ready to Ready Transition

The library generates this type of Unit Attention when the library transitions to a ready state from a not ready state. This transition can occur following any conditions that cause a not ready state. A Unit Attention is generated for all initiators.

CAP Element Accessed

The library generates this type of Unit Attention when the operator opens and closes the CAP. Issue a Read Element Status command to obtain an updated inventory. A Unit Attention is generated for all initiators.

Note – After running Send Diagnostic page code 80 or 81, this Unit Attention sense key will be returned at completion, which indicates that the inventory has changed.

Mode Parameters Changed

The library generates this type of Unit Attention when a different initiator performs a Mode Select operation. Issuing a Mode Sense command can retrieve the current parameters. This Unit Attention is issued for all initiators except the one that performed the Mode Select.

Persistent Reservations/Registrations Preempted or Released

The library generates these types of Unit Attention sense keys when one initiator has its persistent reservations or registrations cleared by another initiator.

Microcode Has Been Changed

The library issues this Unit Attention sense key after executing a Write Buffer command to update the functional microcode for the library.

LUN Data Has Changed

The library generates this type of Unit Attention to all initiators that are affected when the library LUN configuration has changed.

Aborted Command Sense Key

The library generates an Aborted Command error code when a SCSI command is aborted because of a SCSI protocol error. The initiator might not register a Check Condition status related to these errors because of the nature of the aborted commands, but the sense data is available. The following pages describe the conditions of the library that generates Aborted Commands.

TABLE 6-90 Aborted Command Sense Keys

Description	Sense Key	ASC	ASCQ
Mechanical Positioning Error	0Bh	15h	01h
SCSI Parity Error	0Bh	47h	00h
Initiator Detected Error	0Bh	48h	00h
Command Phase Error	0Bh	4Ah	00h
Data Phase Error	0Bh	4Bh	00h
Command Overlap	0Bh	4Eh	00h

Mechanical Positioning Error

The library detected an error while trying to position the PTP and the operation could not be completed.

SCSI Parity Error

The library detected a parity error during a data transfer operation, or the host rejected a Restore Pointers message.

Initiator Detected Error

The library receives an Initiator Detected Error message from the initiator, and the operation could not be completed.

Command Phase Error

The library detected a command phase error and the operation could not be completed.

Data Phase Error

The library detected a data phase error and the operation could not be completed.

Command Overlap

The library detected another command from an initiator while one was already in process.

Request Volume Element Address

The Request Volume Element Address command (B5h) requests that the library return the results of a previous Send Volume Tag command.

TABLE 6-91 Request Volume Element Address Command

Byte	Bit							
	7	6	5	4	3	2	1	0
0	Operation Code (B5h)							
1	Ignored			VolTag	Reserved (0h)			
2 to 3	(MSB)	Starting Element Address						(LSB)
4 to 5	(MSB)	Number of Elements						(LSB)
6	Reserved (00h)							
7 to 9	(MSB)	Allocation Length						(LSB)
10	Reserved (00h)							
11	Control Byte (00h)							

Request Volume Element Address Command Descriptions:

VolTag (Volume Tag)	<p>This bit indicates whether volume tag (VolTag) information is to be reported in response to this command:</p> <ul style="list-style-type: none"> ■ 0 = Volume Tag information is not reported. ■ 1 = Volume Tag information is reported.
Starting Element Address	<p>This field specifies the minimum element address to report. Only elements with an address greater than or equal to the Starting Element Address are reported.</p> <p>The Starting Element Address must be a valid address for the library but does not have to be an address of the type requested in the Element Type Code.</p>
Number of Elements	<p>This field represents the maximum number of element descriptors to be transferred.</p>
Allocation Length	<p>This field specifies the length in bytes of the space allocated by the initiator for the transfer of element descriptors. Only complete element descriptors are transferred. Element descriptors are transferred until one of the following conditions is met:</p> <ul style="list-style-type: none"> All available element descriptors of the type specified in the Element Type Code have been transferred. The number of element descriptors specified in the Number of Elements field has been transferred. There is less allocation length space available than required for the next complete element descriptor or header to be transferred.
Request Volume Element Address Data	<p>The library returns data for a Request Volume Element Address command in:</p> <ul style="list-style-type: none"> ■ An eight-byte Volume Element Address header, followed by ■ One to four element pages, one page per element type. A page consists of: <ul style="list-style-type: none"> ■ An eight-byte Element Status Page header, followed by ■ One or more Element Descriptors. <p>The format of the descriptor is based on the element type reported in this page. There is a separate Element Descriptor format for each element type. The data can be truncated based on the length specified in the allocation length field.</p>

Volume Element Address Header Definition

The Volume Element Address Header is sent once for each command.

TABLE 6-92 Volume Element Address Header

Byte	Bit							
	7	6	5	4	3	2	1	0
0 to 1	(MSB) First Element Address Reported (LSB)							
2 to 3	(MSB) Number of Elements Available (LSB)							
4	Reserved (0h)				Send Action Code (5h)			
5 to 7	(MSB) Byte Count of Report Available (all pages, n-7) (LSB)							
8 to n	Element Status pages							

Volume Element Address Header Definitions:

First Element Address Reported	This field indicates the lowest element address found of the type specified in the Element Type Codes and greater than/equal to the starting address.
Number of Elements Available	This field indicates the number of elements found of the type specified in the Element Type Codes and greater than or equal to the Starting Element Address. This number is adjusted to be less than or equal to the count specified in the Number of Elements field.
Send Action Code	This field contains the value of the send action code field from the previous Send Volume Tag command. The value is 5h.
Byte Count of Report Available	This field indicates the number of bytes of element status data available for all elements that meet the requirements of the Request Volume Element Address command. This count does not include the Element Status Data header bytes. This value is not adjusted to match the allocation length from the command.
Element Status Pages	The element pages returned by a Request Volume Element Address command are the same format as returned by the Read Element Status command. See “Read Element Status” on page 181 for more information.

Reserve (6)

The 6-byte Reserve command (16h) allows the initiator to perform unit reservations or element reservations. Unit reservations are reservations of the library as a whole. Element reservations are reservations of specific elements of the library.

TABLE 6-93 Reserve Command

Byte	Bit							
	7	6	5	4	3	2	1	0
0	Operation Code (16h)							
1	Ignored			Obsolete (0h)				Element
2	Reservation Identification							
3 to 4	(MSB) Element List Length (LSB)							
5	Control Byte (00h)							

Reserve (6) Command Definitions:

Element	This bit indicates if the reserve is an element reserve. The library supports reservation at the element level: <ul style="list-style-type: none"> ■ 0 = The entire library unit is reserved. ■ 1 = A series of elements—identified by the Reservation Identification field and specified by the Element List Descriptor—is reserved.
Reservation Identification	This field is a value established by an initiator to identify a specific element reservation request. The library supports a maximum of 64 element reservations. Note – Ignore this field if the Element bit is not set.
Element List Length	This field indicates the length in bytes of the Element List that follows the command. The list may include a maximum of 16 Element List Descriptors, each of which is 6 bytes long. Valid values are 0, 6, and increments of 6 up to the maximum of 60h (96d). If the value is 0 and the Element bit is set, no elements are reserved. Note – Ignore this field if the Element bit is not set.

Element List Descriptor Definitions

An Element List is required if the Element bit is set. The list consists of 0 to 16 instances of the Element List Descriptor.

TABLE 6-94 Element List Descriptor

Byte	Bit							
	7	6	5	4	3	2	1	0
0 to 1	(MSB) Reserved (00h) (LSB)							
2 to 3	(MSB) Number of Element (LSB)							
4 to 5	(MSB) Element Address (LSB)							

Element List Descriptor Definitions:

Number of Elements	This field indicates the number of elements of a specific type (cartridge tape storage cells, CAP cells, or tape drives) to be reserved. If the value of this field is 0, all elements starting at the Element Address through the last element address for that library are reserved
Element Address	This field indicates the address of the element or the starting address of a series of elements to be reserved.

Other Commands and Reservations

Unit and element reservations are released or canceled by:

- A “Release” command from the same initiator
- A Task Management reset:
 - Bus Device Reset Message
 - Target Reset
 - LUN Reset
- An interface reset
- A power-on reset of the library

If the library is reserved as a unit, the library processes only the following commands from another initiator:

- Prevent/Allow Medium Removal with Prevent bits set to 0
- Inquiry
- Release (the reservation is not released)
- Request Sense
- Report LUNs
- Log Sense

All other commands result in a Reservation Conflict status (18h).

An element reservation may be used to modify or supersede a previous element reservation by the same initiator. If the superseding reservation does not result in any reservation conflicts or error conditions, the previous reservation is released, and the new reservations are completed. A unit reservation of the library supersedes any previous element reservations by the same initiator.

Reserve (10)

The 10-byte Reserve command (56h) allows the initiator to perform unit reservations. Unit reservations are reservations of the library as a whole.

Another capability of the Reserve (10) command as opposed to the Reserve (6) command is the ability to do third party reservations. The third party reservation allows the reservation of a logical unit within a logical unit on behalf of another SCSI device.

TABLE 6-95 Reserve (10) Command

Byte	Bit							
	7	6	5	4	3	2	1	0
0	Operation Code (56h)							
1	Ignored			3rd Pty	Reserved		LongID (0)	Obsolete
2	Obsolete							
3	Third Party Device Id							
4-6	Reserved							
7 to 8	(MSB)	Parameter List Length						(LSB)
9	Control Byte (00h)							

Reserve (10) Command Descriptions:

3rd Pty	This field indicates whether the reservation is on behalf of a third party or not: <ul style="list-style-type: none"> ■ 0 = The reservation is on behalf of the calling requester. ■ 1 = The reservation is on behalf of a specified Third party Device Id.
LongID	The LongID field indicates whether device IDs greater than 255 are required. The library only accepts a value of 0. LongIDs are not supported.
Third Party Device Id	The ID of the third-party device.
Parameter List Length	This field indicates the length in bytes of the Parameter List that follows the command.

Other Commands and Reservations

Unit and element reservations are released or canceled by:

- A Release command from the initiator that owns the reservation (original initiator or the third party)
- A Task Management reset:
 - Bus Device Reset Message
 - Target Reset
 - LUN Reset
- An interface reset
- A power-on reset of the library

If the library is reserved as a unit, the library processes only the following commands from another initiator:

- Prevent/Allow Medium Removal with Prevent bits set to 0
- Inquiry
- Release (the reservation is not released)
- Report LUNs
- Request Sense
- Log Sense

All other commands result in a Reservation Conflict status (18h).

Send Diagnostic

The Send Diagnostic command (1Dh) requests the library to perform a self-diagnostic test. The library may support some self tests in the future but for now considers this command to be a no-operation.

The self-test includes initialization diagnostics and calibration of the library. The extended diagnostics provide random cartridge motions and additional calibration features.

The library disconnects while a diagnostic test is being performed, then reconnects when the diagnostic test completes. This disconnected time can be several minutes, and time-outs should be adjusted accordingly.

The library returns status based on the diagnostic test result. The Receive Diagnostic command is not used.

TABLE 6-96 Send Diagnostic Command

Byte	Bit							
	7	6	5	4	3	2	1	0
0	Operation Code (1Dh)							
1	Ignored			PF	Rsvd (0)	SelfTest (1)	DevOfl (0)	UnitOfl (0)
2	Reserved (00h)							
3 to 4	(MSB) Parameter List Length							(LSB)
5	Control Byte (00h)							

Send Diagnostic Command Descriptions:

PF	The library supports the page format (PF) specified by SCSI-3. The value of PF should be 1. However, the library accepts a 0 for self test.
SelfTest	The library returns a value of 1, indicating a request to the library to complete the library's default test.
DevOfl	This feature is not supported by the library; the value is set to 0.
UnitOfl	This feature is not supported by the library; the value is set to 0.
Parameter List Length	For the self-test option, a value of 0h is required. For extended diagnostics, a value of 8h is required. (not supported)

Send Diagnostic Data

For extended diagnostics, the initiator must provide Send Diagnostic parameter data in a parameter list that include.

- A page code
- Diagnostic parameters

TABLE 6-97 Send Diagnostic Data

Byte	Bit							
	7	6	5	4	3	2	1	0
0	Page Code							
1	Reserved (00h)							
2 to 3	(MSB) Page Length (0004h)							(LSB)
4 to 7	(MSB) Diagnostic Parameters							(LSB)

Send Diagnostic Data Definitions:

Page Code	This field specifies which extended diagnostic test is to be executed: 90h = Uncalibrate
Page Length	This field specifies the number of bytes in the parameter list, which follows. The value is always 0004h.
Diagnostic Parameters	This field is reserved and is set to 0h.

Diagnostic Operations

Because the Receive Diagnostic command is not supported, check the error log (also referred to as the events log) following a diagnostic failure. This provides specific details of the error. The error log is available via a log sense command or from the operator panel.

The uncalibrate diagnostic (page code 90h) uncalibrates all target data. This forces the library to recalibrate during subsequent operations.

Note – The library generates a Not Ready to Ready Unit Attention Sense Key for all other initiators after diagnostic operations have completed.

Send Volume Tag

The Send Volume Tag command (B6h) is a request for the library to transfer a volume tag template. The template corresponds to a VOLSER label template and is used by the library to search for desired elements. A subsequent Request Volume Element Address command is used to transfer the results of this search.

TABLE 6-98 Send Volume Tag Command

Byte	Bit							
	7	6	5	4	3	2	1	0
0	Operation Code (B6h)							
1	Ignored			Rsvd (0)	Element Type Code			
2 to 3	(MSB) Starting Element Address							(LSB)
4	Reserved (00h)							
5	Reserved (00h)			Send Action Code (5h)				
6	Reserved (00h)							
7	Reserved (00h)							
8 to 9	(MSB) Parameter List Length							(LSB)
10	Reserved (00h)							
11	Control Byte (00h)							

Send Volume Tag Command Descriptions:

Element Type Code	<p>This field specifies the element types selected for reporting by this command:</p> <ul style="list-style-type: none"> ■ 0h = All Element Types reported ■ 1h = Medium Transport Element (hand) ■ 2h = Storage Element (cartridge tape storage cells) ■ 3h = Import/Export Element (CAP cells and PTP cells) ■ 4h = Data Transfer Element (tape drive) <p>For an Element Type Code of 0h, the element types are reported in ascending element address order, beginning with the first element greater than or equal to Starting Element Address.</p>
Starting Element Address	<p>This field specifies the element address at which to start the search. Only elements with an element address greater than or equal to the Starting Element Address are reported.</p> <p>The Starting Element Address must be a valid address for the library, but does not have to be an address of the type requested in the Element Type Code.</p>
Send Action Code	<p>This field specifies the function to be performed. The library only supports the translate and search primary volume tag function. The value is 5h.</p>

Parameter List Length	This field indicates the length in bytes of the Parameter List that follows the command: <ul style="list-style-type: none"> ■ 00h = No data is transferred ■ 28h = A Volume Identification Template is transferred ■ A value of 0 is not considered an error.
------------------------------	--

Send Volume Tag Parameter List

The Send Volume Tag command requires a parameter list that defines the volume template to search for.

TABLE 6-99 Send Volume Tag Parameter List

Byte	Bit							
	7	6	5	4	3	2	1	0
0 to 31	(MSB)	Volume Identification Template						(LSB)
32	Reserved (00h)							
33	Reserved (00h)							
34 to 35	(MSB)	Minimum Volume Sequence Number						(LSB)
36	Reserved (00h)							
37	Reserved (00h)							
38 to 39	(MSB)	Maximum Volume Sequence Number						(LSB)

- **Volume Identification Template**
This ASCII field specifies a volume identification search template. A maximum of 6 ASCII characters may be used. The first 00 hex terminates the volume identification search template. The remaining characters are set to 0.
- Characters allowed are the same as those used on the cartridge VOLSER labels and include characters A through Z, digits 0 through 9, and special characters that include the dollar sign (\$), the pound character (#), and the ASCII space character.
The wild-card characters "*" and "?" (2Ah and 3Fh) also may be used.
- **Minimum Volume Sequence Number**
Sequence numbers are not supported on the library; ignore this field.
- **Maximum Volume Sequence Number**
Sequence numbers are not supported on the library; ignore this field.

Test Unit Ready

The Test Unit Ready command (00h) allows the initiator to determine if the library is powered-on and ready to accept additional commands. This is not a request for a library self-test.

The Test Unit Ready command returns a Good status if the library is ready to accept additional commands. This command also returns a Check Condition if the library is not ready or if there are pending Unit Attentions.

TABLE 6-100 Test Unit Ready Command

Byte	Bit							
	7	6	5	4	3	2	1	0
0	Operation Code (00h)							
1	Ignored			Reserved (00h)				
2	Reserved (00h)							
3	Reserved (00h)							
4	Reserved (00h)							
5	Control Byte (00h)							

Write Buffer

The Write Buffer command (3Bh) updates the functional microcode for the library. A sequence of one or more Write Buffer commands that updates the microcode is called a download.

A change in the initiator from one Write Buffer command to another in a multiple-transfer download is considered a new download process request, and terminates the active process.

This allows another initiator to download microcode if the first initiator goes down before completing its download request.

Caution – Potential IPL problem: Make sure that the download of the microcode has completed successfully before you attempt to IPL the library. The IPL will fail if the download has been unsuccessful. For more information about downloading microcode, refer to the library installation manual.

A successful download writes new microcode to the flash memory and resets the library after the final Write Buffer command completes.

The library performs block verification on the first 32 bytes of data and a CRC over the entire image after the last command. A unit attention is set for all initiators other than the initiator that requested the download with the additional sense code set to Microcode Has Been Changed.

TABLE 6-101 Write Buffer Command

Byte	Bit							
	7	6	5	4	3	2	1	0
0	Operation Code (3Bh)							
1	Ignored			Reserved (0h)		Mode		
2	Buffer ID (00h)							
3 to 5	(MSB) Buffer Offset							(LSB)
6 to 8	(MSB) Parameter List Length							(LSB)
9	Clear Partial Images		Control Byte (00h)					

Write Buffer Command Descriptions:

Mode	<p>This field indicates the type of download to be performed. The library supports two modes:</p> <hr/> <p>110b = Download Microcode with Offsets</p> <ul style="list-style-type: none"> ■ This mode is used for multiple transfer downloads. ■ The first Write Buffer command must contain data for the start of the image ■ The remaining commands must send data in order. ■ The library does not check for data overlap. It is up to the initiator to keep track of the amount of microcode transferred and the microcode placement. ■ This mode cannot be used exclusively to download microcode. It is used for all Write Buffer commands in a download except for the last one. <hr/> <p>111b = Download Microcode with Offsets and Save</p> <ul style="list-style-type: none"> ■ This is the last Write Buffer command to tell the library that the download is finished. ■ A change to this mode from any other mode is considered a new download request, and terminates any active download.
Buffer ID	<p>This field defines the region of memory to be modified. Currently only a value of 00h is supported. A non-zero value returns a Check Condition status with an Illegal Request sense key. The additional sense code is set to Invalid Field in CDB that identifies Byte 2.</p>
Buffer Offset	<p>This field identifies the offset from the start address of the load area into which the data is placed. For modes 100b and 101b, this field is set to 0.</p> <p>A non-zero results in a Check Condition status with an Illegal Request Sense Key. The additional sense code set to Invalid Field in CDB that identifies Byte 3 (the parameter list length). For modes 110b and 111b, this field is ignored.</p>
Parameter List Length	<p>This field indicates the number of bytes being sent to the library. A length of 0 is allowed for mode 111b only. Blocks are limited to a maximum of 16,384 bytes. The length value must be an even number; an odd number results in a Check Condition with an Illegal Request sense key. The ASC will be set the Invalid Field in CDB identifying Byte 6. Any other error also results in a Check Condition status with an Illegal Request sense key. The ASC will be set to Invalid Field in CDB identifying Byte6.</p>
Clear Partial Images	<p>This field is used to clear any partial images currently stored as a result of prior Write Buffer commands using the Download Microcode With Offsets mode. The value is set to 01b and the mode is set to Download Microcode With Offsets.</p>

Cell Maps

This appendix describes the SL500 Library System walls, cartridges cells (slots), and location scheme.

Library Walls

There are three types of walls in the library:

- *Left side wall*, which consists of 4-cartridge cell arrays
- *Right side wall*, which consists of 3-cartridge cell arrays and 1 CAP array
- *Rear wall*, which consists of either 3-cartridge expansion cell arrays or 1 drive array

[FIGURE A-1 on page 237](#) and [FIGURE A-2 on page 238](#) show valid slot and drive locations.

Cartridges placed in cells lie flat, hub down and parallel to the floor. To prevent slippage, cartridges are held within their cell by internal retainer clips.

Cartridge Cell Locations – Data Cartridges

Cartridge locations in previous libraries were listed by Panel, Row, and Column.

Cartridge cell designations within a SL500 library require four parameters LSM, Module, Column, Row:

1. **LSM (Library number)** — Within a library or library complex
2. **Module** — Modules are numbered 1,2,3... etc., from the top of the library to the bottom
3. **Column number** – Columns are represented by numbers 1 through 11. Column 1 is the front most column on the left side of the library, and columns increase to column 4 along the left wall. Column 5 is on the right side of the library closest

to the rear wall, and the columns increase to column 8 at the front of the right wall. The rear wall of the library is column 9 for drives, or 9 through 11 for expansion cells.

4. **Row number** – The row numbers start at 1 in a module for the first accessible row within a column. Columns under drives start row 1 in the third cell position since the top two cells are not accessible.

FIGURE A-1 on page 237 through FIGURE A-2 on page 238 illustrate where these terms apply; Table A-2 on page 239 shows slot counts for different LTO cartridge configurations.

Column numbering starts with 1 at the front of the front column and continues to 4 at the back left. Then column 5 is at the back right and proceeds to column 8 at the right front. If drives are in the module, the drives are column 9. If Storage cells are in the back, column 9 starts at the left back column and proceeds to the right to column 11 in the back.

Cell Maps

FIGURE A-1 on page 237 and FIGURE A-2 on page 238 show valid slot and drive locations.

Table A-2 on page 239 shows slot counts for different LTO cartridge configurations.

Default Element Mapping

The following rules apply to the default element mapping

- The medium transport element (hand) is element 0d
- The first import/export element (CAP) is element 10d
- The first data transfer element (drive) is element 500d
- The first storage element (slot) is element 1000d

The following tables shows the default first element and last element addresses in the SL500 library.

TABLE A-1 First and Last Element Addresses

Type of Element	First Element Address	Variables Affecting Last Element Address	Last Element Address
Hand	0d	None	0d
SL500 CAP slots	10d	None	55d
Drives	500d	None	518d
SL500 capacity	1000d	None	1628d

FIGURE A-1 Base Module Slots

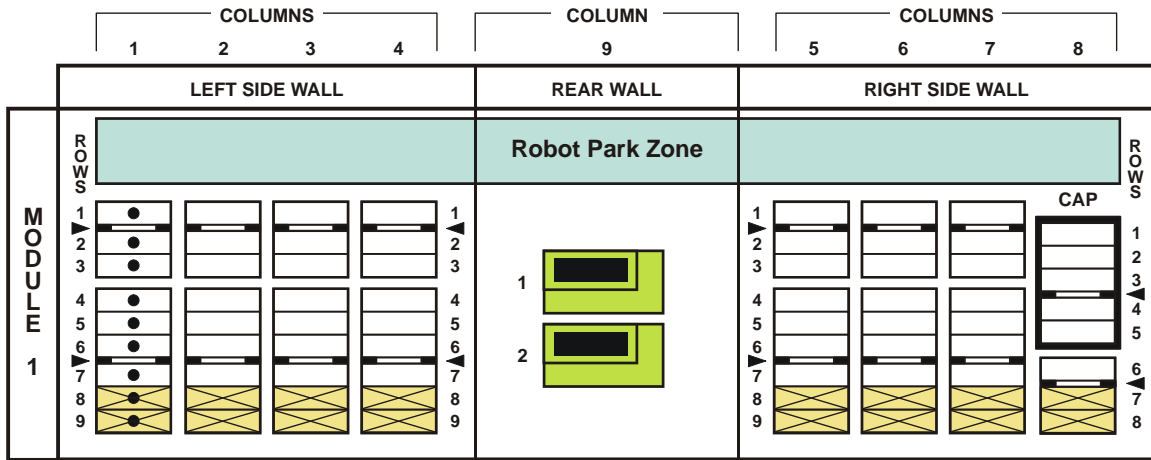

L204_165

1. Slots available for customer data cartridges
2. Slots only available when an expansion module is installed
3. Slots for cleaning and diagnostic cartridges
4. Array targets
5. Tape drives

FIGURE A-2 Base Module and Drive Expansion Module Slots

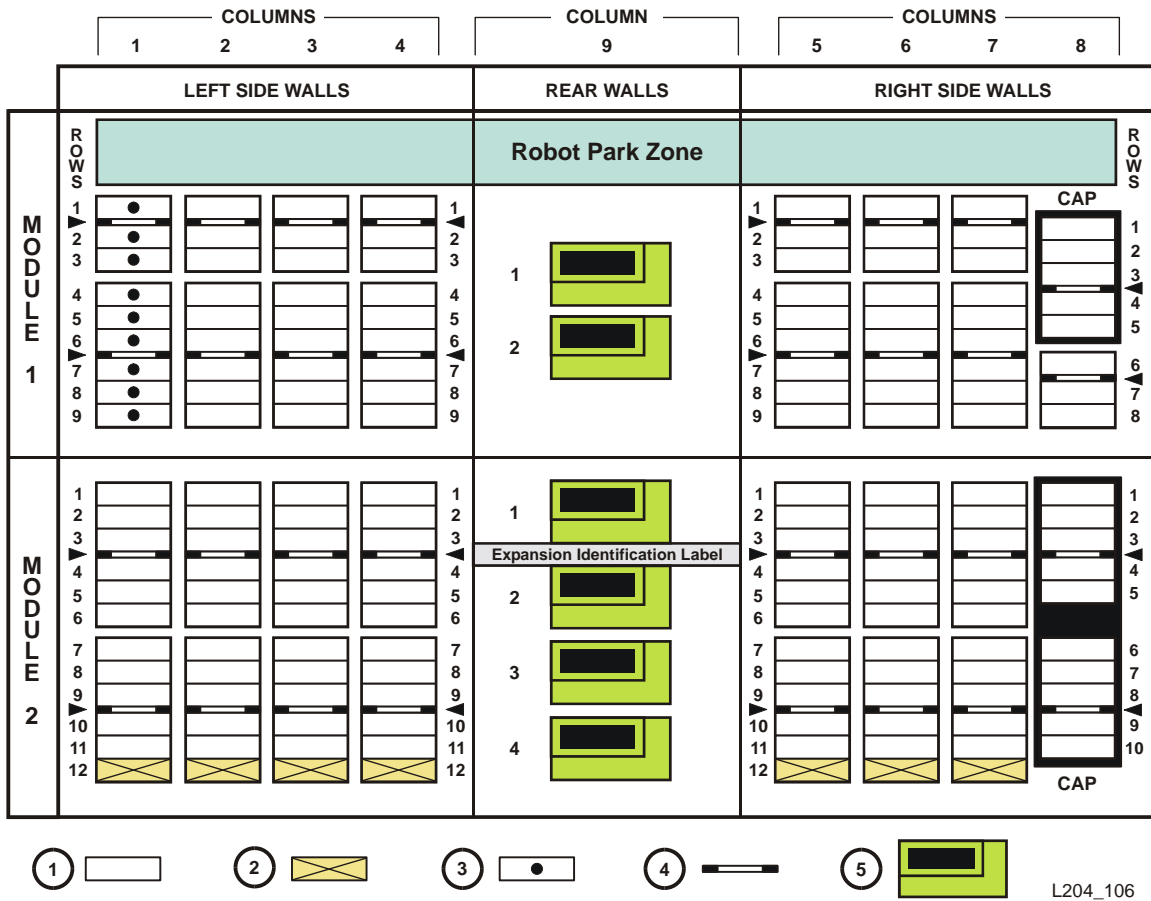

L204_106

1. Slots available for customer data cartridges
2. Slots only available when an expansion module is installed
3. Slots for cleaning and diagnostic cartridges
4. Array targets
5. Tape drives

At FRS, the library only supports LTO Ultrium Linear Tape-Open (LTO) Generation 2 tape drives. The following table shows how many LTO cartridges can be placed in the library, depending on the modules installed.

TABLE A-2 Slot Counts for Different Configurations

	Base module	Drive Expansion Module	Total Slots	Playground	CAPs as Storage Slots	Maximum Drives
Base module	43		43	7		2
Base module + 1 drive expansion module	57	77	134	9	10	6
Base module + 2 drive expansion modules	57	161	218	9	20	10
Base module + 3 drive expansion modules	57	245	302	9	30	14
Base module + 4 drive expansion modules	57	329	386	9	40	18

Note: When the CAP slots are used for storage slots, add the number in that column to the number in the total slots column.

Diagnostic and Cleaning Cartridge Locations

A total of 7 cells (base unit only) or 9 cells (with expansion modules) may contain diagnostic and cleaning cartridges. The customer may elect to not set any reserved cells, in which case these are just normal storage cells.

Locations of these cells are within the arrays positioned on Column 1, the front most column on the left side of the library in the Base Module.

Since the safety barrier may be moved during a maintenance activity, online customer access to these cell locations would not be allowed; this is why the area is reserved for non-data cartridges.

Partitioning Overview

The SL500 library can now be partitioned into various sections. Briefly stated, this means that instead of one library—with all its cartridge slots, tape drives, and CAPs—being a single entity, the library and these components can now be divided into multiple sections, up to a maximum of eight partitions. Each partition can be accessed by one host or multiple hosts.

Partitioning—Feature

If your customer has ordered the partitioning feature for the library, you must work with the systems administrators who will be involved with assigning the partitions.

Note: – *Important:* You must enable the partitioning feature through the CLI port. To do this, you must obtain advanced service permission and the advsrv password. You must contact support and supply the customer's site location and the machine's serial number.

Partitioning is an option. Licensing is required to enable the feature.

Clear communication and cooperation among system programmers, network administrators and Sun service representatives are essential. Be sure to share this information with all those involved in the partitioning effort and, if need be, correspond with other members of the Sun service community when assistance is required.

Note: – *It is best that all questions are answered before attempting to partition a library.*

Partitioning—General

Partitioning has terms associated with it that you and your customer must understand to effectively use the feature. In certain cases, these terms redefine some concepts that are familiar with users of the traditional, non-partitioned library configuration.

A “partition” is defined as the process of dividing portions of a library into discrete sections. The partitioning feature offers great flexibility for users. A partition can be as small as a single storage slot, a single CAP slot, or one tape drive if desired. A library can also contain multiple partitions. Customers could also set up a single and/or multiple partitions that are accessible by single or multiple hosts.

The key to understanding partitioning is knowing what partitions exist, their boundaries, and who has access to the specific partitions that are configured.

Setting up a partition requires some important considerations:

- If one partition designates several tape drives solely to its partition, no other partitions can use these tape drives.
- Partition users must also anticipate how much storage area is needed for their resident tape volumes and the amount of free slots required.
- CAP assignments are also critical. CAP slots can be specifically assigned to certain partitions or left open for common use. This will be discussed in detail later.

Storage slots and drives that are *not* assigned a partition within a partitioned library cannot be accessed. A customer could leave an area of slots unassigned, for example, in preparation for a planned future partition.

The SCSI element numbering within partitioned libraries is continuous for each partition, even if slot locations for each partition are non-contiguous. Using [FIGURE 0-1](#) as an example, if one partition owns the base and cartridge expansion modules, SCSI element numbering begins at the first available slot in the base module and continues through the cartridge expansion module slots. For the partition owning the driving expansion module, the first slot in that module will begin the element numbering for that partition and continue throughout the module.

Partitioning—Access Control

Host definitions are assigned to specific partitions. Customers can assign multiple host definitions to a single partition. However, they cannot assign the same host definitions to multiple partitions. For example, Partition 1 could be set up for hosts 2, 3, and 4; Partition 2 could have hosts 1 and 5 for host definitions. They could not, however, assign host 1 or 5 to *both* Partitions 1 and 2.

The host definition consists of:

- Host ID (WWN)
- Port number
- Logical unit number (LUN)

FIGURE 0-1 Partitioning a Library

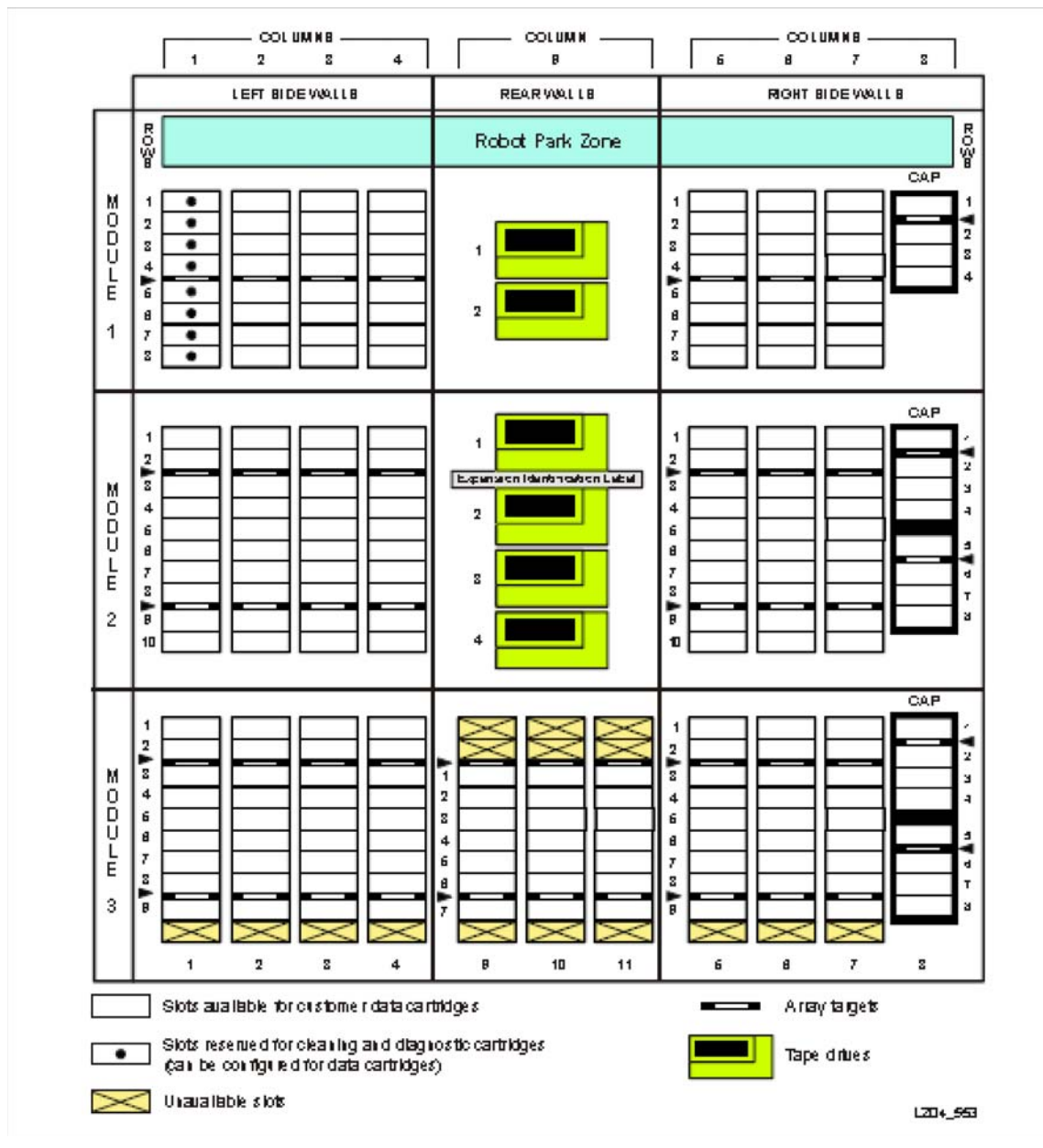

Partitioning—Location Numbering

Location numbering is composed of four digits: Library number, Module number, Row number, and Column number.

In a non-partitioned library configuration, the location number for the library always begins with the number “0.” For partitioned libraries, however, the library number will change to the partition number.

If Partition 1 was composed of the entire base module, locating a cartridge in module 1, row 8, column 1 in the base module would translate into the following: 1, 1, 8, 1.

If Partition 2 was composed of the entire drive expansion module, row 10, column 1 would translate into 2, 2, 10, 1.

Partitioning—CAP Behavior

Whereas cartridge slots and drives can be partitioned, CAPs (or CAP slots) can be configured for:

- Assignment to a specific partition only (split assigned CAP)
- Common use for those partitions that do not specifically assign slots (common CAP)
- A combination of specific slots and common slots (mixed CAP)

Customers could conceivably partition two slots in an 8-slot CAP to a single partition and the remaining slots to a second partition, for example.

For partitioned libraries, these three configuration options for CAP assignments are explained below.

Split Assigned CAPs

As cartridge slots and tape drives can be partitioned, CAPs or CAP slots can be assigned to the sole use of a partition. When specific CAP slots are assigned to a *specific partition*, the split assigned CAP option is enabled

Careful planning in regard to anticipated CAP usage is required when using this option. *Only those CAP slots designated as split assigned can be used by the partition assigning them.*

Split Assigned CAPs—Example

The library (see [FIGURE 0-1 on page 243](#)) is composed of a base, drive and cartridge expansion modules. All cartridge slots, drives and CAP slots in the base module comprise Partition 1. All cartridge slots, drives and CAP slots in the drive expansion and cartridge expansion modules are assigned to Partition 2. Each partition has access to *only* the components configured for it.

If Partition 1 requests a CAP *import* operation, the procedure is:

- The operator selects Partition 1’s CAP through either the local operator panel or StreamLine Library Console.
- The CAP button on the base module is pressed.
- The top CAP door is opened. All remaining CAP doors remain closed.

- The operator completes the operation.

If Partition 2 requests a CAP *import* operation, the procedure is:

- The operator selects Partition 2's CAP through either the local operator panel or StreamLine Library Console.
- The CAP button on the base module is pressed.
- The top CAP door remains closed. All remaining CAP doors open.
- The operator completes the operation.

Multiple split CAP assignments are available within a library. This is in contrast to common assigned CAPs (see below).

Note – As the default behavior, if *no* partition has selected a CAP through the operator panel or StreamLine Library Console, the library will behave as if all split configured CAPs have been assigned to the CAP button. When the button is pressed, all CAP doors that are designated as split assigned will open to expose *all* split configured CAP slots, provided that no common configured CAP slot containing a cartridge is exposed.

Common Unassigned CAPs

The common (or unassigned) CAP configuration is present when there are no specified CAP slots designated (split assigned) to a partition or partitions. Strictly speaking, one does not “configure” or “assign” a CAP as common—any CAP slots that are not split assigned are available for mutual use among the remaining, unassigned partitions. Keep in mind that common CAPs are a single unit, shared among those partitions that have no split assigned CAPs.

Common Unassigned CAPs—Example

Referring to [FIGURE 0-1 on page 243](#), Partition 1 is set up to contain all cartridge slots and drives in the base module for a single host. The remaining cartridge slots and drives are a second partition used only by a second host. However, no CAP slots are explicitly assigned for a partition—both partitions can use all CAP slots.

An example of an *import* operation sequence for a common CAP would be:

- The operator selects the CAP through either the local operator panel or StreamLine Library Console.
- An operator presses the CAP button.
- All CAP doors open.
- A cartridge is placed in any CAP slot.
- The CAP door is closed.
- The cartridge is placed into a slot within the requesting host's partition.

In a second instance, assume that Partition 2 requests a CAP *export* operation of a cartridge. Since it is a common CAP, the operation would be:

- The operator selects the CAP through either the local operator panel or StreamLine Library Console.
- The VOLSER of the cartridge to be exported is entered.
- The cartridge is placed in any CAP slot.

- All CAP doors open.
- The operator completes the operation.

For common CAPs, slots may be used by all partitions who do not specifically assign them. However, only one partition can select a CAP for operation at one time. The operation must be completed before the CAP is released to someone else through either the operator panel or StreamLine Library Console.

Mixed CAPs

A mixed CAP option is present when both split CAP and common CAP configurations are present within a library.

Mixed CAPs—Example

Referring again to [FIGURE 0-1 on page 243](#), Partition 1 contains only the cartridge in module 1, column 5, row 1, and drive number 1 and the single CAP slot 1 in the base module. The remaining storage slots and drives are divided among partitions 2, 3, and 4. The remaining CAP slots are left unassigned. These unassigned CAP slots are usable by partitions 2, 3, and 4, but CAP slot 1 in the base module can only be used by Partition 1.

If Partition 1 requests a CAP *export* operation, the procedure is:

- The operator selects its CAP through either the local operator panel or StreamLine Library Console.
- The VOLSER of the cartridge to be exported is entered.
- The cartridge is placed into the top CAP slot of module 1's CAP.
- The top CAP door is opened. All remaining CAP doors remain closed.
- The operator completes the operation.

If Partitions 2 through 4 request an *export* operation, the procedure is:

- The operator selects a CAP through either the local operator panel or StreamLine Library Console. For this example, assume that Partition 2 has selected the top CAP for placement of the cartridge.
- The VOLSER of the cartridge to be exported is entered.
- The cartridge is placed into any module 1 CAP slot *except* the top one.
- All CAP doors open.
- The operator closes all CAP doors.

Within mixed assigned CAP environments:

- For common CAPs, one or more partitions can share those CAP slots not designated as split assigned.
- For split assigned CAPs, *several* configurations are possible. For example, the 4-slot CAP in a base module could be split assigned to Partition 1; the top four slots in the drive expansion module's CAP could be split assigned to Partition 2; the bottom four slots in the drive expansion module's CAP could be split assigned to Partition 3, and so forth. To fulfill the mixed definition, however, there must also be common CAP slots available.

The CAP Button—Its Function in Partitioned Libraries

A significant difference between a non-partitioned library's CAPs and those of a partitioned library must be noted. For a non-partitioned library, pressing the CAP button opens all CAPs that are configured as CAPs. *In a partitioned library, each partition must first have its CAP selected, using the operator panel or StreamLine Library Console. This will dedicate the CAP button to the use of those partitions that selected a CAP or CAPs for operation.* After selection, pressing the CAP button will open *only* the CAP doors assigned to that partition.

If *not* selected by any partition, pressing the CAP button will open only those CAP slots that are split assigned (see the note [on page 245](#)).

An important thing to remember is that if multiple partitions are assigned to the same CAP slots (that is, common slots)—and that CAP is selected for use by one partition—the CAP import/export operation must be completed and the new partition assignment made, before another member of that partition can gain access for CAP operations.

Partitioning—Problem Scenarios

This section describes problems that may arise in partitioned libraries. Generally speaking, customers who use the partition feature must:

- Know the partition boundaries
- Know the CAP assignment characteristics for each partition
- Select a CAP before performing a CAP operation
- Complete the CAP operation in order to release the CAP to other partitions. As a safeguard, a CAP will *not* open to expose a cartridge that belongs to a partition that has *not* selected the CAP.

Cartridge Importing

The customer wishes to import a cartridge into a partitioned library's CAP. The operator presses the CAP button, but no CAP doors open.

- In this case, a CAP owned by that partition was not selected through the operator panel or StreamLine Library Console. In partitioned libraries, CAPs must be assigned to a partition.

The customer has the CAP in module 1 configured as a split CAP. The top slot belongs to Partition 1 and the remaining slots belong to Partition 2. Partition 2 selects the CAP in the base module, presses the CAP button and opens the CAP to import a cartridge. The operator places the cartridge into the *top slot* and closes the CAP door.

- In this case, Partition 2 does not own the top slot; therefore, the CAP door will re-open and the cartridge must be removed by the operator and placed in the proper CAP slot.

The customer selects the correct CAP for an import operation, but the CAP does not open.

- One possibility is that there are no empty cartridge slots for the operation—the cartridge partition is full.

A customer tries to select a CAP, but its status is listed as “inaccessible” (or CAP open, or a unit check is posted, depending on host software)

- The CAP requested is currently selected by another partition which can also access the CAP. That host’s CAP operation has not been completed. This exemplifies the need for cooperation and communication among hosts using a partitioned library.

Cartridge Exporting

The customer has four cartridge slots within a base module as Partition 1; one CAP slot (the top one again) is a split CAP with only the top CAP slot configured. Partition 1 selects the top CAP, then follows the procedure to export all four cartridges.

- In this situation, the top CAP will open each time a cartridge is placed in the top slot. The CAP must be opened/closed four times to complete the command.

A customer tries to select a CAP, but its status is listed as “inaccessible.”

- The CAP requested is currently selected by another partition which can also access that CAP.
- Another partition has exported a cartridge to one of the three bottom slots in the CAP, but the CAP door has not been opened yet to retrieve the cartridge.

Remember:

- A CAP will *not* open to expose a cartridge for a partition that is not assigned to the CAP button.
- A CAP operation must be completed in order to release the CAP to other partitions.

Partitioning—Removing the Feature

If the customers for your library decide that they wish to remove the partitioning feature, they simply remove all partitions and it will revert to a non-partitioned library configuration.

Partitioning—Configurations

For CLI configuration entries, you must keep the following in mind for partitioned libraries:

1. Library firmware must be version 1220 or higher.
2. Be sure you have configured the reserved slots for diagnostic cartridges (use the reserved <number of cell> | <print> command) *before* enabling partitioned. The reserved slots will appear as black (unavailable, masked from the customer's cartridge database) when the customer displays the library interior in StreamLine Library Console.

Note – You cannot adjust reserved slots *after* the library is partitioned.

3. To configure CAP characteristics for entry/ejection of cartridges (as opposed to storage) you must use the cap <module#> <io|storage> command in [TABLE B-1 on page 250](#)), to specify the CAPs in *each module* as “io” (input/output) *before* enabling partitioning.

Note – Once a library is partitioned, any change to CAP configurations requires the library resource affected to be re-partitioned.

4. You must know the cartridge label orientation used by each partition within a partitioned library and enter this information through the orientlabel <host|oppanel> command (see [TABLE B-1 on page 250](#)).
5. You must login to the CLI port with the advsrv user ID to enable the feature (see [TABLE B-1](#))

Library and Tape Drive Configurations

Note – You might not be able to use the StreamLine Library Console to configure the library and tape drives. Use the CLI commands in the following tables or type `help lib` or `help drive` for a list of the commands.

TABLE B-1 CLI Commands for Library Configuration

<code>allowpartitions <print on off></code>	Enables/disables the partitioning feature.
	Note: You must have an <code>advsrv</code> password for this command.
<code>autoclean print (firmware level 1022)</code>	Shows the library's current setting
<code>autoclean <on off></code> (firmware level 1022)	Sets the auto clean option on or off. <i>On</i> causes tape drives to be automatically cleaned when needed. <i>Off</i> disables automatic cleaning. If the host software is handling tape drive cleaning, set the option to off.
<code>cap <module#> <io storage></code>	Configures the specific module's CAP as input/output or storage
<code>cartridge print</code>	Shows the location, volume serial number, and media type for all cartridges
<code>cartridge print reserved</code> (firmware level 1022)	Shows the location, volume serial number, and media type for reserved cartridges
<code>clearcartcount print</code> (firmware level 1022)	Shows the library's current list of cleaning cartridges and cleaning counts
<code>clearcartcount <label> count</code> (firmware level 1022)	Sets the number of times a particular cleaning cartridge can be used. The cartridge must be in the cleaning list. The cleaning list is not complete until the audit is finished.
<code>cleanwarnthreshold print</code> (firmware level 1022)	Shows the library's current warning threshold count for cleaning cartridges
<code>cleanwarnthreshold <count> <drivetype></code> (firmware level 1022)	Sets a warning threshold count for the number of cleans a cartridge can perform for a given tape drive type before a warning is issued. <code><drivetype></code> is "lto" or "dlt". If the value is set to 0, no warning is issued.
<code>lib getconfig</code>	Shows the library configuration

TABLE B-1 CLI Commands for Library Configuration (Continued)

lib setconfig	Sets the specified library's Fibre Channel or SCSI configuration
orientlabel <host oppanel> <all left8 left7 left6 right6 right7 right8> <partition> <i>See Note at Right</i>	Sets the host (Sun) orientlabel parameter. This option causes the bar-code label on the cartridge to be presented to the host interface as all or fewer characters, selected from the left or right of the physical label. Note: For partitioned libraries, you must enter the label orientation for each partition (the "<partition>" field has been added for this feature).
upsidedowndetect <on off>	Sets the upsidedowndetect option. On is the default setting and allows the library to detect upside down SDLT cartridges in <i>mixed-media</i> libraries. Off disables the checking function.

TABLE B-2 CLI Commands for Tape Drive Configuration

drive all (firmware level 1022)	Shows information for all tape drives
drive <addr> clean (firmware level 1022)	Cleans the specified tape drive. A label may be specified when prompted.
drive <addr> getconfig drive 0,1,1,9 getconfig	Shows a specified tape drive's Fibre Channel or SCSI configuration
drive <addr> gettime	Shows a specified tape drive's time of day (TOD) clock setting
drive <addr> info	Shows a specified tape drive's information
drive <addr> setconfig	Sets a specified tape drive's Fibre Channel or SCSI configuration
drive <addr> settime	Sets a specified tape drive's time of day (TOD) clock
drive <addr> state	Shows a specified tape drive's operational state.

Partitioning—Library Console

Once enabled, customers can set a library's partitions through the StreamLine Library Console interface. The basic procedures are described in the *SL500 User's Guide*, part 96116, and the following sections.

Glossary

This glossary defines terms and abbreviations in this and other product related publications.

Numerics

2N A PDU that supplies power to the redundant AC power grid and the third and fourth accessory racks. *See also* N+1.

A

access door A door on either side of the front facade through which service personnel can enter the library. Optional CAPs are attached to the right access door.

accessory rack An area of the drive and electronics module that is used for Product Name library electronic and power equipment and for other standard 19-inch rack-mount electronic equipment. Up to four racks are permitted in the electronics/drive assembly. Rack-mount equipment must be on the approved equipment list.

array A partitioned unit that holds multiple objects, such as cartridges or tape drive tray assemblies.

asynchronous (ASYNC) Not synchronized; not occurring at regular, predetermined intervals. Asynchronous transmissions send one data character at a time, at irregular intervals, rather than in one steady stream; a start bit and a stop bit notify the receiver when the transmission begins and ends. *Contrast with* synchronous. (GLS Glossary)

audit *See* host audit and security audit.

automation bezel A tape drive attachment with a locator target for positioning gets and puts to the tape drive.

B

backplane The main circuit board inside electronic equipment that contains the central processing unit, the bus, memory sockets, expansion slots, and other components. (GLS Glossary)

bar code line scan camera A component of the robot that is used for cartridge identification and position calibration.

blind mate connector A connector that allows hot plugging instead of manually placing a cable between two fixed connectors.

bulk load Manually loading cartridges into the library, for example, during library installation.

C

CAP *See* cartridge access port.

card *Synonymous with* printed wire assembly.

cartridge access port (CAP) A device in the library that allows an operator to insert or remove cartridges during library operations. (GLS Glossary)

Synonymous with import/export mail slot in SCSI and open system libraries.

cartridge bias Left or right justification of a cartridge within a storage cell, CAP, or tape drive.

cartridge mover *See* robot.

cartridge proximity detector A component that determines if a cell is empty or contains an unlabeled cartridge during a label reading error recovery procedure. *Synonymous with* empty cell detector.

CCD (1) Charge couple device.

(2) Cell contents database.

cell The location in the library in which a tape cartridge is stored. *Synonymous with slot.*

cell array An array that holds multiple cartridges when not in use.

The Product Name library uses 8-cell, 13-cell, and 14-cell arrays for cartridge storage.

cleaning cartridge A tape cartridge that contains special material to clean the tape path in a transport or drive. (GLS Glossary)

CLI Command line interface.

cold swap To remove and replace a system component (typically one such as a logic board that has no redundant backup) after system operations have been stopped and system power has been disabled. *Contrast with hot swap.* (GLS glossary)

CompactPCI (cPCI®) Industry standard bus used for card-to-card bus expansion.

cPCI *See* CompactPCI.

customer interface module The front module of the SL500 library at which the customer has access to the touch screen operator panel and service personnel have access to the library and service bay.

D

data cartridge A term used to distinguish a cartridge onto which a tape drive may write data from a cartridge used for cleaning or diagnostic purposes. (GLS Glossary)

diagnostic cartridge A data cartridge with a “DG” label that is used for diagnostic routines. (GLS Glossary)

DLE Data link escape.

drive and electronics module The module in an Product Name library that houses the electronics control module, power distribution units (PDUs), power supplies, accessory racks and equipment, and tape drives for the library.

drive array assembly An array that is installed in the drive and electronics module for mounting tape drive tray assemblies. The drive and electronics module holds up to four array

assemblies, and each array holds up to 16 tape drive tray assemblies.

drive bay A partitioned section of the tape drive array assembly that holds one tape drive tray assembly.

drop-off cells Cells used to hold a cartridge in the event of a robot failure that occurs while a cartridge is in the robot hand.

E

ECM *See* electronics control module.

electronics control module The assembly that:

- Processes commands from a host system
- Coordinates the activities of robots, elevators, pass-thru ports, and tape drives
- Monitors status inputs from sensors and switches

elevator The device that transports cartridges vertically, across rail boundaries.

emergency power-off (EPO) (1) A safety scheme that allows a “power down” of a subsystem or a system as a whole instead of powering it down component-by-component. (GLS Glossary)

(2) A safety switch on a machine or in a data center that allows a user to immediately power down a machine or a data center power supply by cutting off the external source power. (GLS Glossary)

Enterprise Systems Connection (ESCON) (1) A set of fiber-optic based products and services developed by IBM that allows devices within a storage environment to be dynamically configured. A channel-to-control unit I/O interface that uses optical cables as a transmission medium. (GLS Glossary)

environmental monitors A collective term for the sensors that track temperatures, fan speeds, and the status of various other mechanism within a library.

EPO *See* emergency power-off.

ESCON *See* Enterprise Systems Connection.

Ethernet A local-area, packet-switched network technology. Originally designed for coaxial cable, it is now found running over shielded, twisted-pair cable. Ethernet is a 10- or 100-megabytes-per-second LAN. (GLS Glossary)

export The action in which the library places a cartridge into the cartridge access port so that the operator can remove the cartridge from the library. *Synonymous with eject.*

F

failover The act of moving to a secondary or redundant path when the primary path fails.

FFC Flat flexible cable.

Fibre Channel A bidirectional, full-duplex, point-to-point, serial data channel structured for high performance capacity. The Fibre Channel is an interconnection of multiple communication ports, called N_Ports. These N_Ports are interconnected by a switching network, called a fabric, to a point-to-point link, or an arbitrated loop. Fibre Channel is a generalized transport mechanism with no protocol of its own. A Fibre Channel does not have a native input/output command set, but can transport existing Upper Level Protocols (ULP) such as SCSI and IPI. Fibre Channel operates at speeds of 100 MB per second (full speed), 50 MB per second (half speed), 25 MB (quarter speed), or 12.5 MB (eighth speed). Fibre Channel operates over distances of up to 100 m over copper media or up to 10 km over optical links. (GLS Glossary).

fibre connection (FICON) An IBM S/390-based channel architecture that provides up to 256 channels in a single connection, each having a capacity of 100 MB per second. (GLS Glossary)

FICON *See* fibre connection.

front controller module The module that houses the controller for the elevators, CAPs, turntables, and safety barrier.

front facade The external portion of the customer interface module, between the access doors, that holds the:

- Membrane keypad
- Product logos

- Optional touch screen operator control panel

G

get An activity in which a robot obtains a cartridge from a cell or drive. (GLS glossary)

gripper (1) The portion of the hand assembly that grasps the cartridge. (GLS Glossary)

(2) The part of the hand assembly that grasps and holds a cartridge during transport.

H

hand assembly A part of the library robot whose function is to grasp cartridges and move them between storage cells and drives. A camera on the hand assembly reads cartridge volume labels. (GLS Glossary)

See also bar code line scan camera.

HBZ module *See* front controller module.

host audit The process of updating the cartridge VOLIDs and locations (collected by a security audit) in a host CDS. This audit is initiated by a host command.

Host Software Component (HSC) (1) A host-resident software package, implemented on mainframe operating systems (such as MVS), that influences device allocation and intercepts mount and dismount requests to automate these requests.

(2) That portion of the automated cartridge system (ACS) that executes on host systems attached to an automated library. This component acts as the interface between the operating system and the rest of the ACS.

(3) Host-resident software that controls the automated cartridge system (ACS). The library database records cell status, characteristics, and disposition of all cartridges stored in the library.

hot swap Removal and replacement of a system component while system power remains on and system operations continue. *Contrast with cold swap. Contrast with hot-pluggable. Synonymous with online servicing.*

hot-pluggable The capability that allows a CSE to replace FRUs while power to the FRU is maintained. This feature allows hardware maintenance actions and hardware upgrades to proceed without disrupting subsystem availability. *Contrast with* hot swap. (GLS Glossary)

I

import The process of placing a cartridge into the cartridge access port so that the library can insert it into a storage cell. (GLS Glossary)

Synonymous with enter.

interlock switch A switch that disconnects power to library mechanisms, excluding tape drives, when the front door is opened. (GLS Glossary)

K

keypad interface *See* membrane keypad.

L

LibCam Monitoring A feature that provides two cameras, one for each leg of the horseshoe, for viewing activity inside the library. The touch screen operator control panel is required.

library camera *See* LibCam Monitoring.

library complex (1) Two or more Product Name libraries attached to each other with PTPs.

(2) Two Product Name libraries attached to each other with PTPs in which one library is the Master library and the other is the Standby library for pass-through purposes.

library controller (LC) The HBC card within the Product Name library that controls operations and communicates with the operator panel.

library operator panel *See* touch screen operator control panel.

logical library A virtual representation of a physical library. *Synonymous with* virtual library partition.

M

magazine A removable array that holds cartridges and is placed into the cartridge access port (CAP). (GLS Glossary).

master (pass-thru port) The side of a pass-thru port (PTP) that contains the electronics that control the actions of the PTP. *See also* standby (pass-thru port). (GLS Glossary)

membrane keypad A keypad mounted on the front facade used to monitor the status of the SL500 library and to operate the CAPs.

N

N+1 A PDU that provides power to the redundant AC power grid. *See also* 2N.

O

online replacement Replacement or service of a module while the library remains operational. The service person may be required to power off the module before removing or replacing it. *Synonymous with* hot swap.

operator panel *See* touch screen operator control panel.

P

pass-thru port (PTP) A mechanism that enables a cartridge to pass through from one library to another in a multiple modular library system.

PCI Peripheral component interconnect.

PDU *See* power distribution unit.

physical library A single Product Name library consisting of a customer interface module, robotics interface module, and an drive and electronics module, with one to three Storage Expansion Modules optional. *See also* logical library.

PLC Power line communications.

PLI *See* primary library interface.

power distribution unit (PDU) A device for the distribution of AC line power from one inlet to multiple outlets. Multiple PDUs provide higher availability because the power continues if one PDU (or its alternating current [AC] source if the PDUs use separate AC sources) loses power. (GLS Glossary)

power grid A power circuit that minimizes power failures that cause the library to cease operations.

An Product Name library has five power grids, two for AC power and three for DC power.

power/communication bus rail A rail that sits on the robot track to provide 48 VDC power and communication to the robot.

primary library interface (PLI) The communication path between the operator panel and the library controller (the HBC card.) This consists of Ethernet with TCP/IP and XML.

PTP *See* pass-thru port.

put An activity in which a robot places a cartridge into a cell or drive. (GLS Glossary)

PWA Printed wiring assembly.

R

rail (1) That portion of the upper robot track assembly that provides power and communication to the robot.

rail assembly The mechanism on which the robot travels between cartridge arrays and tape drives.

reach mechanism A component of the robot that moves the gripper to get or put a cartridge at a designated location.

remote operator console The customer's operator panel that interfaces with the PLI. *See also* security software layer.

robot A mechanism that moves horizontally along a track in the Product Name to transport tape cartridges to and from other locations in the library. *Also called* an S-bot or t-bot.

robotics interface module The module containing the curved rails and pass-through port (PTP) assemblies.

S

safety barrier A motor-driven barrier that separates the service areas of the front interface assembly from the rest of the library so that service personnel can safely repair or replace failed library mechanisms while the library continues normal operations.

S-bot Small robot.

security audit The process of reading and storing in Product Name library memory the VOLIDs and locations of all cartridges in the library. *See also* host audit.

security software layer (SSL) The communication path between the PLI and the remote operator console.

service area An area between the access doors of the customer interface module and the safety barrier in which an inoperable robot is stored for service and other mechanisms can be repaired or replaced.

SL500 *See* StreamLine™ 500 Modular Library System.

SSi System Server infrastructure.

standby (pass-thru port) The side of a pass-thru port (PTP) that operates in response to actions initiated by the master side of the PTP. *See also* master (pass-thru port). (GLS Glossary)

storage expansion module An optional module for the Product Name library that provides up to 1728 additional cartridge storage slots. From one to three modules can be attached to each library.

StreamLine™ 500 Modular Library System An automated tape library comprised of:

- Base module containing the robotics unit
- Drive expansion module
- Cartridge expansion module

T

tape cartridge A container holding magnetic tape that can be processed without separating the tape from the container. The library uses data, diagnostic, and cleaning cartridges. These cartridges are not interchangeable.

tape drive An electromechanical device that moves magnetic tape and includes mechanisms for writing and reading data to and from the tape. (GLS Glossary)

tape drive tray assembly The mechanical structure that houses a tape drive, fan assembly, power and logic cards, cables, and connectors for data and logic cables. *Synonymous with* drive tray assembly.

tape storage area The area in the Product Name library where cartridges are stored.

tape transport interface (TTI) An interface to control/monitor tape movement. (GLS Glossary)

t-bot Tall robot.

touch screen operator control panel An optional feature consisting of a flat-panel display with a touch screen interface and a panel mount computer. This feature is attached to the front facade.

track The horizontal path upon which a robot travels.

track drive mechanism The component that moves the robot along the track between the cell arrays, CAPs, and tape drives.

TTI *See* tape transport interface.

turntable A mechanism that transfers cartridges between the aisles within a single library.

U

U A standard unit of measurement of vertical space inside a rack-mount cabinet equal to 44.5 mm (1.75 in.). (GLS Glossary)

UART Universal asynchronous receiver/transmitter. (GLS Glossary)

V

vacancy plate A plate that covers an unused bay, such as a drive bay or power supply bay.

W

wrist A mechanism in the robot assembly that allows the robot to access the outer and inner storage walls.

Index

Numerics

8B/10B encoding 45

A

abort

 exchange 57

 message 25

 sequences 57

about the interface 1

ABTS 57

ABTX 57

A-cable to P-cable adapter 12

ACK signal 18

Acknowledge signal 18

acquiring addresses 47

adapter, description of 12

address failures 48

ADISC 57, 79

ADVC 57

advise credit 57

AL_PA 46

AL_PD 47

AL_PS 47

AL_TIME 65

alert messages in manual xxiv

Allowed (definition of) 42

arbitrate to win loop 34

arbitrated loop

 physical address 46

 timeout value 65

Arbitration phase 17

arrays, locating cartridges 229

asynchronous

 negotiation 27

 transfers 17

ATN signal 18

Attention

 condition 20

 signal 18

attributes, task 77

B

basic link

 data frame 56

 services 57

BB_Credit 67, 68

benefits of SCSI 3

BSY signal 18

buffer-to-buffer credit 67, 68

bus

 conditions 20

 device reset message 26

 phases 15

 signals 18

Bus Free phase 16

Busy signal 18

busy status 28

C

C/D signal 18

cable

 adapter 12

 interconnections 12

 length, maximum 40

 maximum lengths 7

 SCSI interface 8

camp on 54, 55

cartridges

 locations

 data 229

 diagnostic & cleaning 233

 placement in cells 229

caution

 LVD cable impedance 8

 signal interference 8

CDB 86

cell

 data cartridge locations 229

 described 229

 diagnostic & cleaning cartridges 233

 maps 230

check condition 28

Class 3 service

 general 53

 parameters 55

 Fabric login 55

- port login 54
- clearing effects, Fibre Channel 80
- close latencies 51
- codes
 - FCP response 74
- Command
 - phase 17
 - signal 18
- command
 - complete message 25
 - confirmation, Fibre Channel 76
 - control byte 87
 - descriptor blocks 86
 - information unit 72
 - pointers 23
- Commands
 - operation code 86
- commands
 - no operation (NOP) 57
 - Release 199
 - status byte 28
- commands and data, PRLI 69
- commands, Fibre Channel
 - basic 57
 - extended 57
 - link service 56
- commands, Fibre Channel. See also commands 57
- company ID 52
- conditions, SCSI bus
 - Attention 20
 - Contingent Allegiance 21
 - general 20
 - Parity Error 20
 - Unit Attention 22
- connection status block 58
- connectors, types of 10
- Contingent Allegiance condition 21
- control byte 87
- CRC, (cyclic redundancy check) 64
- credits, zero 51
- current pointers 23
- cyclic redundancy checks 64

D

- Data
 - Bus parity signal 18
 - Bus signal 18
- data
 - and response, in same sequence 69
 - field size 67, 68
 - Information Transfer phase 17
 - information unit 73
 - phase 17
 - pointers 23
 - signal 18
 - transfers, wide 27
- Data Bus
 - parity signal 18
 - signals 18
- DB signal 18
- decoding 45
- dedicated simplex 54
- delimiters
 - end-of-frame 46
 - start-of-frame 53
- device
 - reservations 82
 - states 44
- differential
 - alternatives 7
 - sense signal 11
- disconnect message 25
- discover
 - address 57
 - parameters 57
 - SCSI target
 - private loop 78
 - public loop 78
- disparity 45

E

- E_D_TOV 65
- echo 57
- encoding 45
- end-of-frame delimiters 46
- EOF 46
- errors
 - detection 43

- link error status block 59
- sequence 64
- errors. See also failures
- establish
 - image pair, PRLI 69
 - streaming 57
- ESTC 57
- estimate credit 57
- ESTS 57
- examples
 - bus conditions 20
 - bus phases 16
 - pointer operation 23
 - Reselection phase 17
 - Selection phase 17
 - Unit Attention condition 22
- exchange
 - identifier 61
 - management 62
 - originator 62
 - read status block 59
 - responder 62
- extended link
 - data frame 56
 - service commands 57

F

- F_CTL features 56
- fabric
 - attachment initialization 51
 - login 58
- failures
 - error detection 43
 - loop 49
- failures. See also errors 64
- FAN 78
- fast load 29
- FC Tape terms 42
- FC-0
 - and device states 44
 - and initialization 44
 - defined 44
- FC-1
 - and initialization 45
 - defined 45

- disparity 45
- encoding/decoding 45
- FC-2
 - Class 3 service 53
 - frame format/header 61
- FC-3 67
- FC-4 69
- FCP
 - other features 78
 - task attributes 77
- FCP_RSP 74
- FC-PH 4
- features
 - fast load 29
 - multiple initiators 29
- fiber-optic cables
 - connectors xxvii
 - handling precautions xxviii
 - installation xxvii
- Fibre Channel
 - basic link service commands 57
 - class 3 service
 - parameters, Fabric login 55
 - parameters, port login 54
 - clearing effects 80
 - command confirmation 76
 - extended link service commands 57
 - FC-0 44
 - FC-1 45
 - FC-3 67
 - FC-4 69
 - frame format 61
 - levels 41
 - link service commands 56
 - response to link services 60
 - See also commands
 - tape terms 42
 - terms in manual 42
 - timers 65
 - versions 67, 68
- FLOGI 58
- format
 - status byte 28
- frame
 - control features 56
 - header

- contents 61
- exchange management 62
- format 61
- illustration of 61
- sequence management 63

G

- GAID 58
- GBIC 5
- get alias 58
- glossary 247
- good status 28

H

- hardcopy publications xxv
- head of queue 77
- header frame, contents of 61
- high-voltage differential SCSI (HVD)
 - compatibility 11
 - TERMPWR 11
- HSSDC 40

I

- identifier, sequence 63
- identify messages 26
- implementation of SCSI 3
- Information Transfer phase 17
- Information Units
 - command 72
 - data 73
 - response 73
 - transfer ready 73
- initialization completion
 - private loop 49
 - public loop 49
- initiator
 - control 54, 55
 - definition of 42
 - detected, error message 25
- initiators, multiple support 29
- installation, fiber-optic cables xxvii
- interconnections, wide to narrow bus 12
- interface cables
 - construction 8
 - daisy-chain 9

- maximum lengths 7
- minimum lengths 7
- part numbers 9
- types of 8

- interlock 56
- intermix mode 54, 55
- Invokable (definition of) 42

L

- label, laser product xxvii
- laser product label xxvii
- latencies 51
- LIFA 47
- LIHA 47
- LILP 49
- link
 - error status block 59
- link service
 - commands 56
 - extended commands 57
 - responses to 60
- LIP 36
- LIPA 47
- LIRP 48
- LISA 48
- LISM 48
- locations
 - data cartridges 229
 - diagnostic & cleaning cartridges 233
- login credits 51
- LOGO 52, 58
- logout services 58
- loop
 - addresses 47
 - failures 49
 - master 48
- loop initialization
 - fabric assigned address 47
 - hard assigned 47
 - loop position 49
 - previously acquired 47
 - protocol 36
 - report position 48
 - soft assigned 48

- loop port state machine 36
- low-voltage differential SCSI (LVD)
 - cable impedance 8
 - characteristics 7
 - compatibility 11
 - terminators 10
 - TERMPWR 11

LPSM 36

M

- management, Fibre Channel
 - error detection 43
 - exchange 62
 - sequence 63

master loop initialization 48

Message

- phases 17
- signal 18

messages

- abort 25
- bus device reset 26
- command complete 25
- disconnect 25
- extended message 25
- identify 26
- initiator detected error 25
- no operation 26
- overview 24
- parity error 26
- reject 26
- restore pointers 25
- save data pointers 25

MSG signal 18

multiple initiator support 29

N

N_Port

- alias 58
- and jitter 36

negotiations

- synchronous & asynchronous 27
- wide 27

no operation (NOP), command 57

no operation message 26

NOP (no operation command) 57

notes, description of xxiv

numbering

- cartridges

- data cell locations 229

- diagnostic & cleaning cartridges 233

O

open

- latencies 51
- originators 51
- sequence 63

optional headers 56

options, SCSI 8

ordered queue 77

organization of information in this manual xxiii

originator, exchange 62

OX_ID 62

P

parity

- message error 26

parity error

- defined 20

part numbers

- adapter, P-cable to A-cable 12

Partners Web site xxv

payload response 74

PDISC 79

phases, SCSI bus

- Arbitration 17

- Bus Free 16

- figure of 16

- general 15

- Information Transfer 17

- Command 17

- Data 17

- Message 17

- Status 17

- Reselection 17

- Selection 17

placement, data cartridges into cells 229

pointers

- description 23

- disconnection 23

- reselection 23

precautions, handling fiber-optic cables xxviii
private loop initialization completion 49
PRLI 58
PRLO 58
process
 login (PRLI) 58
 logout (PRLO) 58
Process Associator 69
Prohibited (definition of) 42
protocol, message 24
PTP-CMC bit 188
public loop initialization completion 49
Publications, related to this manual xxiv

Q

quality of service 58
queue types
 head of queue 77
 ordered 77
 simple 77
 untagged 77

R

R_A_TOV 66
R_CTL features 56
R_T_TOV 49, 65
RCS 58
read
 connection status 58
 timeout value 59
REC_TOV 66
receiver_transmitter timeout 65
recipient control 54, 55
registered state change status 59
reinstate recovery qualifier 59
reject message 26
related publications xxiv
relative offset 67
Release command 199
remove connection 57
report node capabilities 59
REQ signal 18
request sequence initiative 59

Request signal 18
Required (definition of) 42
RES 59
Reselection phase 17
reservation
 conflict 29
 device 82
Reserve command
 element list definitions 218
Reset
 signal 18
 types 21
residual checking 73
resource
 allocation timeouts 66
 recovery timeout 66
responder, exchange 62
response, Fibre Channel
 codes 74
 information unit 73
 payload 74
 to link services 60
restore pointers message 25
RLS 59
RMC 57
RNC 59
routing control 56
RR_TOV 66
RRQ 59
RSCN 59, 78
RSI 59
RSS 59
RST signal 18
RTV 59
running disparity 45
RVCS 59
RX_ID 62

S

safety
 fiber optics xxvi
 laser product label xxvii
same sequence transmissions 69

- saved pointers 23
- SCN 59
- SCR 59
- SCSI
 - adapters 12
 - alternatives 7
 - benefits 3
 - bus phases 15
 - bus signals 18
 - characteristics 7
 - characteristics of 7
 - conditions, description of 20
 - connectors 10
 - implementation 3
 - interface cables 8
 - low-voltage differential (LVD) 7
 - minimum lengths 7
 - options 8
 - overview 1
 - phases 15
 - phases, figure of 16
 - signal source 18
 - signal sources 19
 - single-ended 7
 - special signals 11
 - terminators 10
- SEL signal 18
- Select signal 18
- Selection phase 17
- selective resets 49
- sense length 74
- SEQ_CNT 63
- SEQ_ID 63
- sequence
 - chaining 56
 - concurrent 67
 - errors 64
 - identifier 63
 - management 63
 - open 63
 - retransmission request 60
 - status block 59
- sequential delivery 54, 55
- service, Fibre Channel
 - options 54, 55
 - parameters
 - class 3 55
 - port login, class 3 54
- signals
 - direction & source 18
 - sources 19
 - table of 19
- simple queue 77
- single-ended SCSI
 - cable impedance 8
 - characteristics 7
 - compatibility 11
 - terminators 10
- slots (See also cell) 229
- SOF 53
- SRR 60
- stacked requests 54, 55
- start-of-frame delimiters 53
- state change
 - notification 59
 - registration 59
- status byte, SCSI
 - description of 28
- Status phase 17
- status, SCSI
 - busy 28
 - byte format 28
 - check condition 28
 - good 28
 - reservation conflict 29
- synchronous
 - negotiations 27
 - transfers 94
- system, message 24

T

- Target (definition of) 42
- target discovery 78
- task attributes 77
- terminator
 - power 11
 - types 10
- terms
 - FC Tape 42

- StorageTek 42
- test process login state 59
- third party process logout 59
- timeout values
 - arbitrated loop 65
 - error detect 65
 - read exchange concise 66
 - receiver_transmitter 65
 - resource allocation 66
 - resource recovery 66
 - upper level protocol 66
- timeouts, SCSI 29
- timers 65
- TPRLO 59
- transfer ready information unit 73
- transmission word 42

U

- ULP_TOV 66
- Unit Attention condition 22
- untagged queue 77
- Upper Level Protocol timeout 66

V

- VC status 59

W

- walls 229
- warning
 - eye hazard from laser xxvi
 - radiation from laser xxvi
- wide data transfers 27

X

- XFER_RDY Disabled 69

Z

- zero credits 51

Sun Microsystems, Inc. 4150 Network Circle, Santa Clara, CA 95054 USA Phone 1-650-960-1300 or 1-800-555-9SUN Web sun.com



ARGENTINA: 5411-4317-5636 • AUSTRALIA: 1-800-550-786 • AUSTRIA: 43-1-601-26-0 • BALKANS: 301-6188-111 • BELGIUM: 32-2-704 89 83 • BRAZIL: 55-11-51872100 • BRUNEI: 65-216-8333 • CANADA: 1-800-422-8020 (GENERAL); 416-964-2001 (LEARNING MANAGEMENT SYSTEM SALES, TORONTO) • CHILE: 562-372-4500 • COLOMBIA: 571-629-2323
CZECH REPUBLIC: 420 2 33009311 • DENMARK: 45 4556 5040 • EGYPT: 00 202 570 9442 • FINLAND: 358-9-525-551 • FRANCE: 33-1-41-33-17-17 • GERMANY: 49-89-460-08-2788 • GREECE: 30-01-6188101 • HONG KONG: 852-2877-7077 • HUNGARY: 361-202-4415 • INDIA: 91-80-229-8989 • INDONESIA: 65-216-8333 • IRELAND: 353-1-668-4377
ISRAEL: 972-9-9710500 • ITALY: 39-02-9259511 • JAPAN: 81-3-5779-1820 • KOREA: 82-2-3453-6602 • MALAYSIA: 603-2116-1887 • MIDDLE EAST: 00 9714 3366333 • MEXICO: 525-261-0344 • NETHERLANDS: 31-33-4515200 • NEW ZEALAND: 0800-786-338 • NORTH WEST AFRICA: 00 9714 3366333 • NORWAY: FROM NORWAY: 47-22023950, TO NORWAY: 47-23369650 • PAKISTAN: 00-9714-3366333 • PEOPLE'S REPUBLIC OF CHINA: 8610-6803-5588 • PHILIPPINES: 632-885-7867 • POLAND: 48-22-8747848 • PORTUGAL: 351-21-413-4000 • RUSSIA: 7-095-935-8411 • SAUDI ARABIA: 00 9714 3366333 • SINGAPORE: 65-216-8300 • SOUTH AFRICA: 27-11-256-6300 • SPAIN: 34-902-210-412 • SRI LANKA: 65-2168333 • SWEDEN: 46-8-631 22 00 • SWITZERLAND: 41-1-908-90-50 (GERMAN) 41-22-999-0444 (FRENCH) • TAIWAN: 886-2-25185735 • THAILAND: 662-344-6855 • TURKEY: 90 212 335 22 00 • UNITED KINGDOM: 44-1276-416-520 • UNITED STATES: 1-800-422-8020 • VENEZUELA: 582-905-3800 • VIETNAM: 65-216-8333 • WORLDWIDE HEADQUARTERS: 1-650-960-1300

SUN™ THE NETWORK IS THE COMPUTER ©2006 Sun Microsystems, Inc. All rights reserved. Sun, Sun Microsystems, and the Sun logo are trademarks or registered trademarks of Sun Microsystems, Inc. in the United States and other countries.