

Oracle® Balanced Scorecard

Administration Guide

Release 11i.6 for MS Windows

September 2001

Part No. A90875-01

ORACLE®

Oracle Balanced Scorecard Administration Guide, Release 11i.6

Part No. A90875-01

Copyright © 1996, 2001, Oracle Corporation. All rights reserved.

Primary Authors: Claudia Castro

Contributing Authors: Henry Camacho, Mauricio Eastmond, Patricia Perdomo, Kris Sudharsan, Jui Wang, Julie Yu, Christine Monk, Christopher Andrews

Contributors: German Arciniegas

The Programs (which include both the software and documentation) contain proprietary information of Oracle Corporation; they are provided under a license agreement containing restrictions on use and disclosure and are also protected by copyright, patent, and other intellectual and industrial property laws. Reverse engineering, disassembly, or decompilation of the Programs is prohibited.

The information contained in this document is subject to change without notice. If you find any problems in the documentation, please report them to us in writing. Oracle Corporation does not warrant that this document is error free. Except as may be expressly permitted in your license agreement for these Programs, no part of these Programs may be reproduced or transmitted in any form or by any means, electronic or mechanical, for any purpose, without the express written permission of Oracle Corporation.

If the Programs are delivered to the U.S. Government or anyone licensing or using the programs on behalf of the U.S. Government, the following notice is applicable:

Restricted Rights Notice Programs delivered subject to the DOD FAR Supplement are "commercial computer software" and use, duplication, and disclosure of the Programs, including documentation, shall be subject to the licensing restrictions set forth in the applicable Oracle license agreement. Otherwise, Programs delivered subject to the Federal Acquisition Regulations are "restricted computer software" and use, duplication, and disclosure of the Programs shall be subject to the restrictions in FAR 52.227-19, Commercial Computer Software - Restricted Rights (June, 1987). Oracle Corporation, 500 Oracle Parkway, Redwood City, CA 94065.

The Programs are not intended for use in any nuclear, aviation, mass transit, medical, or other inherently dangerous applications. It shall be the licensee's responsibility to take all appropriate fail-safe, backup, redundancy, and other measures to ensure the safe use of such applications if the Programs are used for such purposes, and Oracle Corporation disclaims liability for any damages caused by such use of the Programs.

Oracle is a registered trademark of Oracle Corporation. Other names may be trademarks of their respective owners.

Contents

Send Us Your Comments	xv
Preface.....	xvii
Intended Audience	xvii
Assumptions.....	xviii
Structure.....	xviii
Related Documents.....	xix
Training and Support.....	xix
Training.....	xix
Support.....	xix
Do Not Use Database Tools to Modify Oracle Applications Data	xx
About Oracle Corporation.....	xx
Thank You.....	xxi
1 Overview	
BSC Components.....	1-2
Design and Administration Tools.....	1-2
BSC Setup	1-2
BSC Architect	1-3
BSC Manager.....	1-4
Web-Based Viewer	1-4
User Types	1-4
General.....	1-5

2 Setup

Logging into BSC Setup	2-1
Setting Up the Database	2-3
Configuring the System	2-4
Adding a New System	2-5
Modifying a System.....	2-7
Deleting a System	2-8
Upgrading a System from a Previous Version	2-9
Importing a System	2-10
Upgrading to a New Version	2-12
Migrating a System	2-15
Creating the Database Link	2-16
Performing the Migration.....	2-17
Database Setup and Export	2-19

3 BSC Builder

Defining General System Properties	3-1
Editing System Name.....	3-1
Configuring System Images	3-2
Defining System Currency	3-3
Creating and Modifying Groups	3-4
Editing Group Properties	3-6
Removing Groups.....	3-7
Using a Source System	3-8
Creating Indicators and Defining Indicator Properties	3-9
Special Note About P&L Indicators	3-11
Copying KPIs Between Groups	3-11
Moving KPIs.....	3-13
Creating Tabs for Custom Scorecards	3-13
Assigning KPIs to Tabs	3-16
Types of Indicators	3-16
Master and Shared KPIs	3-16
Creating Master or Shared KPIs.....	3-17
Effect on Input Tables	3-21
Using the List Button	3-21

Additional List Button Functionality.....	3-23
Setting Up the List Button	3-24
Restrictions on Use of the List Button	3-27
Filtering Dimensions by Tab.....	3-27
Difference Between List Button and Filter By Tab.....	3-28

4 KPI Designer Wizard

Formatting the Layout of Balanced Scorecard Main Views	4-2
Configuring the Scorecard View	4-3
Formatting Directional Lines	4-4
Configuring Additional Views.....	4-4
Configuring the Strategy Map View.....	4-5
Enable Drag & Drop Mode	4-6
Adding Indicators	4-6
Adding Lines.....	4-6
Adding Division Lines.....	4-6
Adding Labels.....	4-7
Zooming In and Out and Increasing and Decreasing the Font Size	4-7
Saving Your Changes.....	4-7
Setting KPI Properties in the Strategy Map View.....	4-9
Setting the Background Color	4-9
Removing a KPI.....	4-9
Enabling the Shadow	4-9
Enabling the Alarm Border.....	4-9
Configuring Custom Views	4-9
Configuring the Custom View	4-10
Loading your base image	4-10
Adding Indicators	4-11
Drag and Drop Indicators	4-11
Additional Options for Indicators in Custom View.....	4-12
Configuring Key Performance Indicators.....	4-13
Configuring Master and Shared KPIs.....	4-13
.....	4-18
Creating Analysis Groups and Options	4-18
Creating Analysis Groups.....	4-20

Analysis Options	4-20
Using Dynamic Dimensions	4-21
Using Datasets and Data Sources.....	4-21
Assigning a Dataset to an Analysis Option	4-21
Setting Properties for a Dataset	4-23
Assigning a Data Source to a Dataset	4-25
Formula Datasets	4-26
Defining Rollup Properties for a Data Source	4-30
Configuring Forecasts	4-35
Configuring Multiple Series KPIs	4-40
Designing Data Dimensions.....	4-44
Creating Data Dimensions	4-44
Creating Dimension Groups	4-47
Assigning Dimensions to Dimension Groups.....	4-48
Dimension Relationships.....	4-49
Assigning Dimension Groups to Dimension Sets	4-52
Moving Dimensions	4-54
Moving Dimension Groups	4-55
A Note about Moving Dimensions	4-55
Defining Key Items.....	4-55
Dimension Properties in Dimension Set	4-57
Assigning Dimensions Sets to Analysis Options.....	4-58
Dimensions - Notes	4-59
Defining Global KPI Settings	4-59
Periodicity.....	4-60
Calculations	4-64
Year to Date Calculation as the Default Entry Method	4-65
Benchmarks	4-66
Fiscal Year and Month	4-68
Cause and Effect	4-69
Alarm Colors	4-71
Specifying User Buttons	4-80
Messaging	4-80
Custom Help.....	4-80
Configuration of Custom Help.....	4-80

Exporting to Excel	4-83
Link Options	4-83
Projection	4-85
User Wizard	4-85
Creating What-If Simulations	4-90
Color Triggers in What-if Simulations	4-98
Special Note About P&L Indicators.....	4-99

5 Metadata Optimizer

Metadata Optimizer and the Design Process	5-2
Configuring Metadata Optimizer	5-3
Setting Configuration Options	5-3
Selecting Calculated and Pre-Calculated KPIs.....	5-4
BSC Calculation Capabilities	5-6
Normal (BSC) Calculated KPIs.....	5-6
Pre-Calculated KPIs	5-7
Running the Metadata Optimizer	5-8
Documenting the Input Tables.....	5-8
system[n].txt.....	5-9
systree[n].xls.....	5-12
mdresult[n].txt	5-13
Populating the Tables	5-15
General	5-16

6 BSC Loader

Loading and Maintaining Dimensions	6-1
Load Dimension Values Before the Input Tables	6-2
Maintaining Dimension Tables	6-2
Updating Dimension Values in Dimension Tables	6-2
Loading BSC Tables	6-4
Define Data Source	6-4
Submitting the Process to the Oracle Applications Concurrent Manager	6-6
Note About Populating Pre-Calculated KPIs Tables	6-6
Change Current Year	6-9
Delete Data	6-9

General.....	6-9
7 Populating and Deploying BSC	
Loading Actual Data in BSC.....	7-2
Creating an Implementation System (Using Actual Test Data)	7-2
Updating KPIs in Implementation Stage.....	7-3
Modifying KPIs in Production Stage (Using Actual Production Data)	7-4
8 BSC Administrator	
Overview of Administrator.....	7-1
Defining Responsibilities.....	7-2
Providing Tab (Scorecard) Access.....	7-2
Global List Values.....	7-3
Dimension Value Filtering (Global List Values)	7-3
Dimension Value Security (Item Values)	7-3
KPI Security	7-4
Using the Administrator.....	7-4
User Information	7-4
Tab Security	7-5
Indicator Security	7-8
Assigning Access to KPIs by Responsibility and Tab	7-9
.....	7-10
A Oracle Applications Security	
B Scheduling Concurrent Requests	
C Multi-User Functionality	
Working in a multi-user environment.....	C-1
Working with multiple users in Architect	C-2
Synchronizing changes between multiple users.....	C-3
Locking mechanism for multiple users working in Architect or Manager.....	C-3
Synchronizing mechanism for populating changes to the Viewer	C-4
Publishing mechanism for applying changes to indicators	C-4

Communicating changes to multiple users	C-4
Locking applications at different levels	C-5
Multi-user logic in the system, tab, and KPI levels	C-6
System Level	C-6
Tab Level.....	C-6
Key Performance Indicator Level	C-7
Global Behavior by modules in multi-user environment.....	C-9
Transactions at System Level.....	C-9
Transactions by Module	C-10
BSC Builder	C-10
KPI Designer	C-12
Metadata Optimizer.....	C-14
Loader	C-15
Security in Administrator.....	C-15
Working with multiple users in the Viewer	C-15

List of Figures

1-1	Login Screen	1-2
1-2	Architect Welcome Screen.....	1-3
2-1	Setup Login Screen	2-2
2-2	System Configuration Tab.....	2-4
2-3	System Configuration Tab.....	2-6
2-4	System Configuration Tab.....	2-8
2-5	System Configuration Tab.....	2-9
2-6	Import Tab	2-11
2-7	System Version Tab, 1.5 to 4.0	2-13
2-8	System Version Tab, 4.0 to 4.0	2-14
2-9	System Migration Tab	2-17
2-10	Target System Name List	2-17
2-11	Responsibility Mapping Frame	2-18
2-12	Filters Frame.....	2-18
2-13	Overwrite Target System Check Box.....	2-19
3-1	Renaming the Default Template and Groups	3-2
3-2	System Images Window	3-3
3-3	Define System Currency.....	3-4
3-4	Template With Sample Groups	3-5
3-5	New Target System	3-6
3-6	Group Properties Window	3-7
3-7	Source System Window.....	3-9
3-8	Dimensions Mapping Window	3-12
3-9	Builder Tabs Window	3-14
3-10	Tab Properties	3-15
3-11	Master Tab Selected.....	3-18
3-12	Shared KPIs Selected in Tab.....	3-19
3-13	Shared KPIs With Two Number Stamps.....	3-20
3-14	List Button	3-22
3-15	Main KPI View Without List Button Enabled	3-22
3-16	Main KPI View With List Button Enabled	3-22
3-17	List Button Dimensions	3-23
3-18	KPI View, No List Button Dimensions Selected	3-24
3-19	KPI View, Region Dimension Selected in List Button.....	3-24
3-20	Dimension Relationships Window	3-25
3-21	Tabs Window, List Button Activated	3-26
3-22	Regional VPs Tab With Filtering Button Selected	3-29
3-23	Filtering Window for Regional VPs Tab	3-30
4-1	Edit Views Icon.	4-5
4-2	Strategy Map View	4-8

4-3	KPI Pop-Up Menu	4-9
4-4	Sales Growth KPI, Configuration Options Disabled.....	4-15
4-5	Sales Growth KPI - Configuration 2	4-16
4-6	Sales Growth KPI - Configuration 3	4-17
4-7	Dependent Analysis Group With Analysis Options.....	4-19
4-8	Independent Analysis Option	4-19
4-9	Dependent Analysis Group With Dependent Groups	4-19
4-10	Assign Dataset Window.....	4-22
4-11	Edit Data Properties Window.....	4-24
4-12	Edit Data Properties Window, Formula Tab.....	4-27
4-13	Edit Source Properties Window, Source Properties Tab	4-28
4-14	Edit Source Properties Window, Source Columns Tab	4-31
4-15	Profit Margin KPI View, Monthly Rollup.....	4-32
4-16	Profit Margin KPI View, Quarterly Rollup.....	4-33
4-17	Total Assets KPI View, Monthly Rollup	4-34
4-18	Total Assets KPI View, Quarterly Rollup	4-35
4-19	Edit Data Properties Window, Dataset Source Tab.....	4-37
4-20	Assign Dataset Window, Multi Series Tab.....	4-42
4-21	Assign Dataset Window, Multi Series Tab, New Series Added.....	4-43
4-22	Define Dimensions Tab	4-45
4-23	Add Dimension Window	4-46
4-24	Dimension Relationships Window	4-49
4-25	Relationship Properties Window	4-50
4-26	Dimension Properties Window.....	4-51
4-27	Assign Dimensions Tab.....	4-53
4-28	Hierarchy of Dimensions to Analysis Options	4-54
4-29	Define Key Items Window	4-56
4-30	Dimension Properties Window.....	4-57
4-31	KPI Window Main Pop-Up Menu	4-60
4-32	Periodicity Window	4-61
4-33	Periodicity Properties Window, Non-Annual Periodicity	4-62
4-34	Periodicity Properties Window, Annual Periodicity	4-62
4-35	Using Periodicity Properties to Enable the Period View Scroll Bar.....	4-63
4-36	Calculations Window	4-64
4-37	Benchmark Settings Window	4-67
4-38	Benchmark Properties Window	4-67
4-39	Define Fiscal Year and Month Window.....	4-69
4-40	Cause and Effect Indicators	4-70
4-41	Define Cause and Effect Indicators.....	4-71
4-42	Define Color Triggers Window.....	4-73
4-43	Prototype Color Menu.....	4-78

4-44	Customizing Alarm Colors	4-79
4-45	Custom Help Settings Window	4-81
4-46	Custom Help Button Properties	4-82
4-47	User Buttons Options Screen	4-84
4-48	Link Properties, Link Entered	4-84
4-49	User Wizard, Parent Options Window	4-86
4-50	User Wizard, Child Options Window	4-87
4-51	User Wizard, Periodicity Options Window	4-88
4-52	User Wizard, Calculation Options Window	4-89
4-53	User Wizard, Dimension Level Options Window	4-90
4-54	Financial Simulation Window	4-92
4-55	Assign Data and Define Formula Window	4-95
4-56	Simulation Tree Dataset Window	4-96
4-57	Edit Node Properties Window	4-99
4-58	Profit and Loss Indicator	4-100
5-1	BSC Design Process	5-2
5-2	Metadata Optimizer Configuration Options Window	5-3
5-3	Metadata Optimizer KPI Calculation Options Window	5-4
5-4	Metadata Optimizer Progress Window	5-8
5-5	Metadata Optimizer Confirmation Window	5-9
5-6	Sample Contents of systree[n].xls File	5-12
6-1	Load Tables Window	6-4
6-2	Define Data Source Window	6-5
7-1	Stages of the BSC Design Process	7-2
8-1	User Information Security Window	7-5
8-2	Tab Security Window	7-6
8-3	Available Tabs List	7-7
8-4	Selecting Tabs From the Available Tabs List	7-7
8-5	Start Date Field	7-7
8-6	End Date Field	7-8
8-7	Indicator Security Window	7-9
8-8	Responsibility Assignments Menu	7-9
8-9	Tab Name Menu	7-10
8-10	Selecting Available Indicators	7-10
A-1	Oracle Applications Login Window	A-2
A-2	Oracle Applications Navigator, Responsibility Definition	A-3
A-3	Oracle Applications, Responsibilities Window	A-4
A-4	Oracle Applications Navigator, User Node	A-5
A-5	Oracle Applications, Users Window	A-6
A-6	BSC Administrator, Tab Security	A-7
A-7	BSC Administrator, Indicator Security	A-8

B-1 Oracle Applications Navigator..... B-1
B-2 Oracle Applications, Requests Window B-2

Send Us Your Comments

Oracle Balanced Scorecard Administration Guide, Release 11i.6

Part No. A90875-01

Oracle Corporation welcomes your comments and suggestions on the quality and usefulness of this document. Your input is an important part of the information used for revision.

- Did you find any errors?
- Is the information clearly presented?
- Do you need more information? If so, where?
- Are the examples correct? Do you need more examples?
- What features did you like most?

If you find any errors or have any other suggestions for improvement, please indicate the document title and part number, and the chapter, section, and page number (if available). You can send comments to us in the following ways:

- Electronic mail: bisdoc_us@oracle.com
- FAX: telephone number Attn: Oracle Balanced Scorecard
- Postal service:
Oracle Corporation
Oracle Balanced Scorecard Documentation
500 Oracle Parkway, 30p1112
Redwood Shores, CA 94065
USA

If you would like a reply, please give your name, address, telephone number, and (optionally) electronic mail address.

If you have problems with the software, please contact your local Oracle Support Services.

Preface

Welcome to Release 11i.6 of *Oracle Balanced Scorecard Administration Guide*.

This guide describes how to administer Oracle Balanced Scorecard, as well as create balanced scorecards for your organization.

This guide contains the following information:

- ❑ Basic features of OBSC Architect (KPI Designer, BSC Builder and Metadata Optimizer) and OBSC Manager (BSC Loader and OBSC Administrator) client modules
- ❑ How to setup and administer OBSC using OBSC Setup and OBSC Administrator
- ❑ How to populate and update your OBSC system using Metadata Optimizer and BSC Loader
- ❑ How to use KPI Designer, BSC Builder and OBSC Setup to customize balanced scorecards for your organization

This preface explains how this publication is organized and summarizes its intended audience, assumptions, and other sources of relevant information.

Intended Audience

This guide is intended for any users involved with installing and administering Balanced Scorecard and using KPI Designer and OBSC Builder to create balanced scorecards, including:

- ❑ Internal and external consultants
- ❑ Analysts who are designing balanced scorecards

- ❑ Financial analysts
- ❑ Systems administrators

Assumptions

This guide assumes that you have a basic understanding of your organization, its strategy and key performance indicators, and the balanced scorecard theory. This guide also assumes that you have a working knowledge of Oracle Balanced Scorecard. If you are not familiar with this application, we suggest you attend one or more of the related training classes that are available through Oracle Education Services. See "Training and Support" on page -xix for more information about Oracle training.

Structure

This guide contains eight chapters and three appendixes:

Chapter 1	Overview
Chapter 2	Setup
Chapter 3	BSC Builder
Chapter 4	KPI Designer Wizard
Chapter 5	Metadata Optimizer
Chapter 6	BSC Loader
Chapter 7	Populating and Deploying BSC
Chapter 8	BSC Administrator
Appendix A	Oracle Applications Security
Appendix B	Scheduling Concurrent Requests
Appendix C	Multi-user Functionality

Related Documents

You can choose from many sources of information, including documentation, training, and support services, to increase your knowledge and understanding of Balanced Scorecard.

For more information, see the following manuals:

- *Oracle Balanced Scorecard Installation Guide*
- *Oracle Balanced Scorecard User's Guide*
- *Oracle Applications System Administrator's Guide*
- *Oracle Applications Installation Guide*

Training and Support

Training

Oracle offers a complete set of formal training courses to help you and your staff master each application product.

You have a choice of educational environments. You can attend Oracle applications courses at any Oracle Education Center, or you can arrange for Oracle trainers to teach at your facility. In addition, Oracle training professionals can tailor standard courses or develop custom courses to meet your needs.

Support

From on-site support to central support, Oracle's experienced professionals provide the help and information you need to keep Balanced Scorecard working for you. This team includes your technical representative, account manager, and Oracle's large staff of consultants and support specialists with expertise in your business area, in managing an Oracle server, and in your hardware and software environments.

Do Not Use Database Tools to Modify Oracle Applications Data

We STRONGLY RECOMMEND that you never use SQL*Plus or any other tool to modify Oracle Applications data unless otherwise instructed.

Oracle provides powerful tools you can use to create, store, change, retrieve, and maintain information in an Oracle database. If you use Oracle tools such as SQL*Plus to modify Oracle Applications data you risk destroying the integrity of your data and you lose the ability to audit changes to your data.

Because Oracle Applications tables are interrelated, any change you make using Oracle Applications can update many tables at once. But when you modify Oracle Applications data using anything other than Oracle Applications, you may change a row in one table without making corresponding changes in related tables. If your tables get out of synchronization with each other, you risk retrieving erroneous information and unpredictable results throughout Oracle Applications.

When you use Oracle Applications to modify your data, the system automatically checks that your changes are valid. Oracle Applications also keeps track of who changes information. If you enter information into database tables using database tools, you may store invalid information. You also lost the ability to track who has changed your information because SQL*Plus and other database tools do not keep a record of changes.

About Oracle Corporation

Oracle Corporation develops and markets an integrated line of software products for database management, applications development, decision support, and office automation, as well as Oracle Applications, an integrated suite of more than 170 software modules for financial management, supply chain management, manufacturing, project systems, human resources, and sales and service management.

Oracle is the world's leading supplier of software for information management, and the world's second largest software company. Oracle offers its database, tools and applications products, along with related consulting, education, and support services in over 140 countries.

Thank You...

Thank you for using *Oracle Balanced Scorecard*.

We value your comments and feedback. At the front of this guide is a reader's comment form you can use to comment on this product. Mail your comments to the following address or call us directly at (650) 506-7000.

Oracle Corporation
Oracle Balanced Scorecard Documentation
500 Oracle Parkway
Redwood Shores, CA 94065
USA

Overview

Oracle Balanced Scorecard (BSC) is part of Oracle's E-Business Intelligence applications. E-Business Intelligence applications support the implementation of strategic management techniques, with the ultimate goal of increasing shareholder value.

The Balanced Scorecard is a strategic measurement and management system that translates an organization's strategy into a comprehensive set of key performance indicators (KPIs). The Balanced Scorecard goes beyond the traditional emphasis on achieving financial objectives to include the performance drivers of these financial objectives. The Balanced Scorecard does this by measuring performance across four perspectives: financial, customer, internal business process, and learning and growth.

Oracle Balanced Scorecard turns the Balanced Scorecard into an active management tool by enabling its deployment across the enterprise. It links strategy to management action by placing the company's key performance indicators right on managers' desktops, giving them direct and quantifiable targets to achieve - targets directly in line with company strategy. By illustrating the cause-and-effect relationships between KPIs, Oracle Balanced Scorecard gives managers a clear understanding of how their decisions impact both their direct area of responsibility and overall company strategy.

In this chapter you'll learn about:

- ❑ BSC design and administration tools
- ❑ BSC's end-user viewer
- ❑ BSC target users

BSC Components

The Oracle Balanced Scorecard design and administration tools include BSC Setup, BSC Architect and BSC Manager. BSC Setup is used to import and upgrade systems from Release 1.5 to Release 11i.6, and migrate an upgraded system from a personal database system to an Oracle Applications database. BSC Setup also lets you register new BSC systems on your computer, so that you can connect from BSC Architect to the database. The BSC Architect contains the components used to design and configure scorecards and load and configure data in the BSC tables.

Design and Administration Tools

These are the tools the system administrator and the designer of BSC use. The set of design and administration tools is BSC Setup, BSC Architect, and BSC Manager. These are client-side modules which require Oracle 8.0.6 client utilities to work.

When logging into Architect and Manager, choose the language you want to use to configure and see your system from the list of supported languages. The user name and password are SYSADMIN for Enterprise Oracle Applications databases.

Figure 1–1 Login Screen

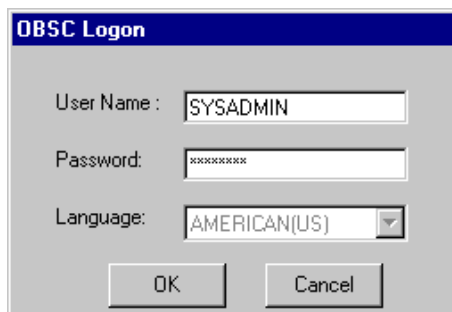

BSC Setup

The Setup Module is used for all tasks related to setting up and managing balanced scorecard systems in the database. This module allows administrators to register the database, import and upgrade balanced scorecard systems from previous versions, and migrate data from one source to a target system in the database.

BSC Architect

When you launch Architect you will see a screen with all the components you will use for your design stage. The entire configuration done in the wizards can be reviewed in the BSC Viewer from a browser window in a three tier architecture. This will allow designers to confirm how end users will see the final configuration of the main views and indicators.

Figure 1–2 Architect Welcome Screen

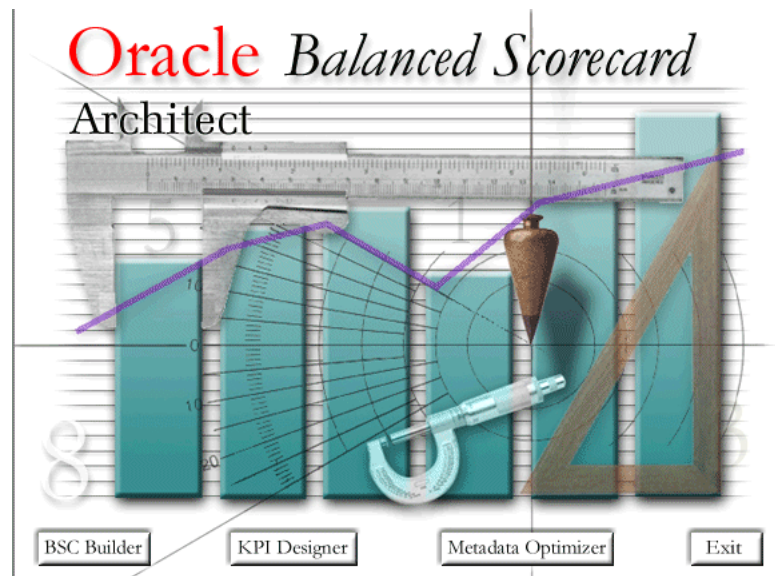

Once balanced scorecards have been set up in the database, they are configured and customized by the administrator using the Architect. There are three sub-modules within the Architect:

- **BSC Builder:** Used to define groupings, indicators and organizational tabs.
- **KPI Designer:** Used to configure the details of each KPI.
- **Metadata Optimizer:** Used to examine all the KPIs that have been defined in the system and creates the necessary input tables which must be filled to populate the balanced scorecard with data.

BSC Manager

The BSC Manager contains the tools needed to load data into the BSC tables and to define security roles. There are two sub-modules in the Manager:

- Loader - once the input tables have been populated, the Loader takes the data from the input tables and populates the system tables that are read by the graphing engine. It is also used to maintain and populate master tables, change the fiscal year or delete data from the system.
- Administrator - the Administrator is used to configure user security (for example, to allow access to only certain tabs for a user). This module is associated to responsibilities and users defined through Oracle Applications (responsibilities and users must be predefined through FND forms). For more information on this, consult the *Oracle Applications Administration Guide*.

Web-Based Viewer

With this release the BSC Viewer is HTML-based, and can be run through a browser such as Netscape Communicator or Internet Explorer. The new HTML-based user front end makes it easier to deploy the OBSC application to a large number of users throughout the enterprise. It also reduces implementation costs when compared to traditional client-server applications.

User Types

Three user types, listed in the table below, can be defined in the Oracle Balanced Scorecard. Each type of user uses a different client component. These user levels can be defined in the BSC Manager.

Table 1-1 User Types

User	Primary Function	Using What Component
Designer	Configures the overall scorecard system, including specific KPI details.	Setup and Architect
Administrator	Loads and updates the data in the balanced scorecard. Also defines and maintains end-user security.	Manager
End-User	Final consumer of the balanced scorecard. Uses and analyzes data in the BSC.	Viewer

►►To completely deploy BSC enterprise wide:

1. Install the application. For installation instructions, refer to the *Oracle Balanced Scorecard Install Guide*.
2. Designers use these tools to perform the indicated tasks:
 - BSC Builder wizard (BSC Architect) - used to define groupings and KPIs (Key Performance Indicators) on the balanced scorecard
 - KPI Designer wizard (BSC Architect) - used to design the main views and indicator details
 - Metadata Optimizer wizard (BSC Architect) - used to create the empty input table structures
3. Administrators populate the input tables with actual client data.
4. Administrators use these tools to perform the indicated tasks:
 - BSC Loader wizard (BSC Manager) - used to load the input tables back into the application
 - BSC Administrator wizard (BSC Manager) - used to define users, access rights and security
5. Deploy the application to end users throughout the enterprise.
6. Continuously update the application with actual & target data.

General

►►To login to BSC Architect:

1. Log into BSC Architect and BSC Manager.
Use SYSADMIN/SYSADMIN as the user name and password to log into any of the modules in BSC Architect and BSC Manager.

Use this tool to register a system in your local machine, import and upgrade a Balanced Scorecard system from a previous version, and migrate data between source and target databases.

This chapter includes the following sections:

- ❑ Introduction to terms
- ❑ Register new systems
- ❑ Upgrade the system version from Release 1.5 to Release 11i.6
- ❑ Migrate a BSC system to an Oracle Applications database

Logging into BSC Setup

►►To login to BSC Setup:

1. Launch BSC Setup from your Window NT shell. The login screen appears:

Figure 2–1 Setup Login Screen

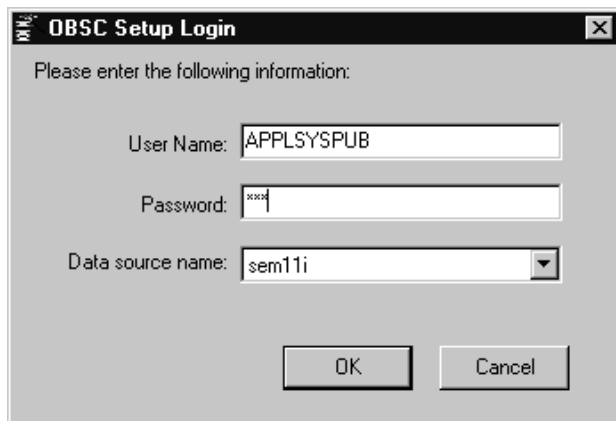

Note: When connecting to BSC Setup, the user name/password are defaulted to APPLSYSPUB/PUB.

2. Select the Data Source Name for the database where this BSC system will reside. This will be the same Data Source Name you defined during the installation process. Remember the relationship: System Name > Data Source Name > Service Name > Oracle Database. Therefore the Data Source Name will point to an Oracle database. User name and password are defaulted with the appropriate parameter APPLSYSPUB/PUB password and should not be modified unless you use a different Oracle system password. Login could fail for any of these reasons:
 - Listener on the server is down
 - Database is down
 - Service name has not been defined and setup
 - Incorrect password
 - User lacks administrative rights
3. When you are finished, click OK to open the main Setup screen. The screen opens in the System Configuration tab.

Setting Up the Database

The System Configuration tab allows you to register new BSC systems on your computer so that you can connect from BSC Architect to the database and start the design phase. The Registered System Name is a pointer to that system in the database.

►► Before registering a new BSC system:

1. Confirm that you have defined the service name and data source name as indicated in the BSC Architect post-installation tasks in the *Oracle Balanced Scorecard Install Guide*.
2. Follow the steps described in Configuring the System on page 2-4.

Configuring the System

Existing BSC systems can be registered, modified and maintained in the System Configuration tab.

Figure 2–2 System Configuration Tab

The screenshot shows a window titled "Setup" with two tabs: "System Configuration" (selected) and "System Migration".

Choose action:

- Add
- Modify
- Delete

Choose registered system name:

- Registered system name: Sem11i
- Description: Sem11i
- Data source name: sem11i
- Service name: sem11i
- GWYUID: APPLSYSPUB/PUB
- FNDNAM: APPS
- NCA Connection: (empty)
- Server id: (empty)
- APPS database

Buttons: OK, Cancel

A Registered System Name - called that because it is used to "register" a shared BSC system on a personal computer - is the name that identifies a BSC system in the database; it is just a pointer to that system. The Registered System Name is specific to, and saved on, a personal computer. Registered System Names appear in the "Open Project" window, whenever the Architect or Manager is launched.

The BSC Setup allows you to add a new Registered Name, to modify the properties for a Registered Name, and to delete a Registered Name.

Note that when adding a new Registered Name and modifying the properties for a System Name, no changes will occur in the database; all the changes will be taken

on the local PC where this wizard is run. Remember, the Registered System Name is a pointer to a BSC system in the database.

Adding a New System

Adding a new system name will register the system and add a new line in the Open Project Window.

Note: You can only have one schema per database in Oracle Applications.

If you are using an Oracle Applications database, you can register your database through the System Configuration tab. In the tab, the APPS checkbox is automatically selected. Four fields are exposed:

Figure 2–3 System Configuration Tab

The GWYUID field houses your gateway ID. The name of your Apps database is displayed in the FNDNAM field. The NCA Connection (URL) and Server ID fields are not required.

Note: This is the only step that you need to perform in the BSC Setup if you want to start with a new system in your Oracle Applications database. Review the other sections in this chapter only if you want to import and upgrade systems from previous versions, or migrate a source system to your Oracle Applications database.

►► Registering the Apps database:

1. Select the Add New System Radio button.
2. Fill in the following fields:

System Name: This is the name that is being registered in your machine pointing to your database. The name you give here will appear in the Project Name window. The system name must be fewer than 15 characters and cannot contain spaces.

Description: Enter a description of the system. The description must be fewer than 80 characters.

Data Source Name: Select the data source name that connects to the correct Oracle Service Name. You can review the data source name by navigating to Start > Settings > Control Panel > ODBC, as described in the *Oracle Balanced Scorecard Install Guide*.

Service Name: This display field shows you the service name to which the data source name connects. You can review your configuration by navigating to Oracle Net8 Easy Config, as described in the BSC Architect post-installation tasks in the *Oracle Balanced Scorecard Install Guide*.

3. Select OK when finished to save your new system.

Modifying a System

Modifying the Registered Name lets you change all the above properties for any BSC system that has been defined on your computer.

►►To modify a registered name:

1. Select the Modify radio button
2. From the Registered System Name drop down list, select the Registered Name you wish to modify properties for.
3. Modify any properties you wish to in the Description, Data Source Name, and Service Name fields. Refer to the field descriptions above.
4. Click OK to save changes.

Figure 2–4 System Configuration Tab

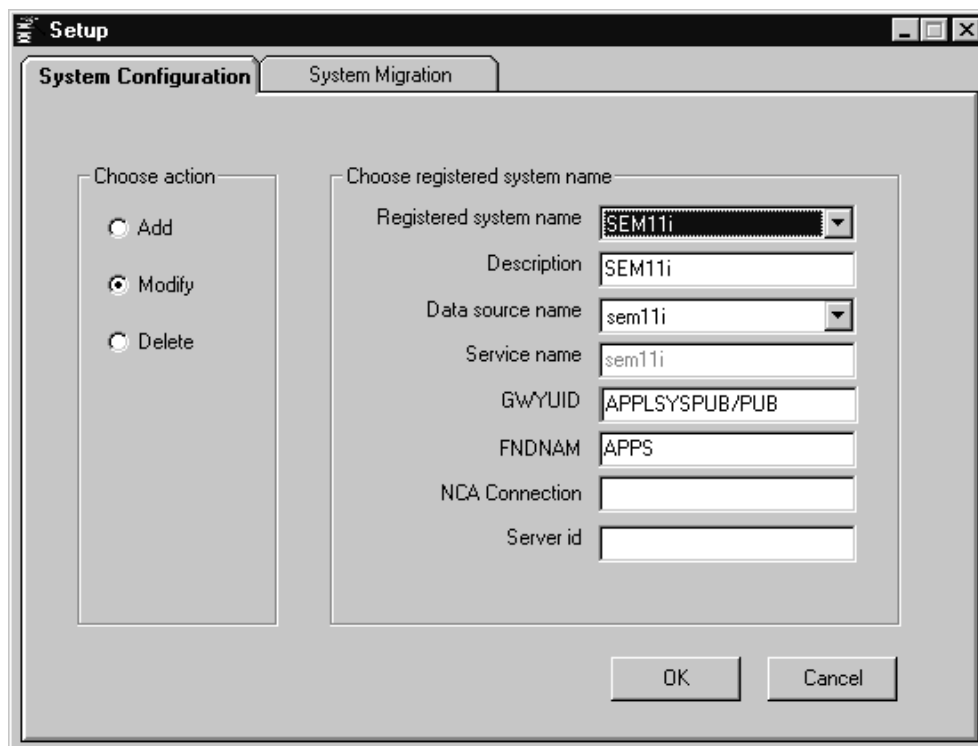

Deleting a System

Deleting a Registered System Name only removes the Registered System Name from the computer where the database is registered and from the Open Project window. It does not actually remove a BSC system from the database.

Figure 2-5 System Configuration Tab

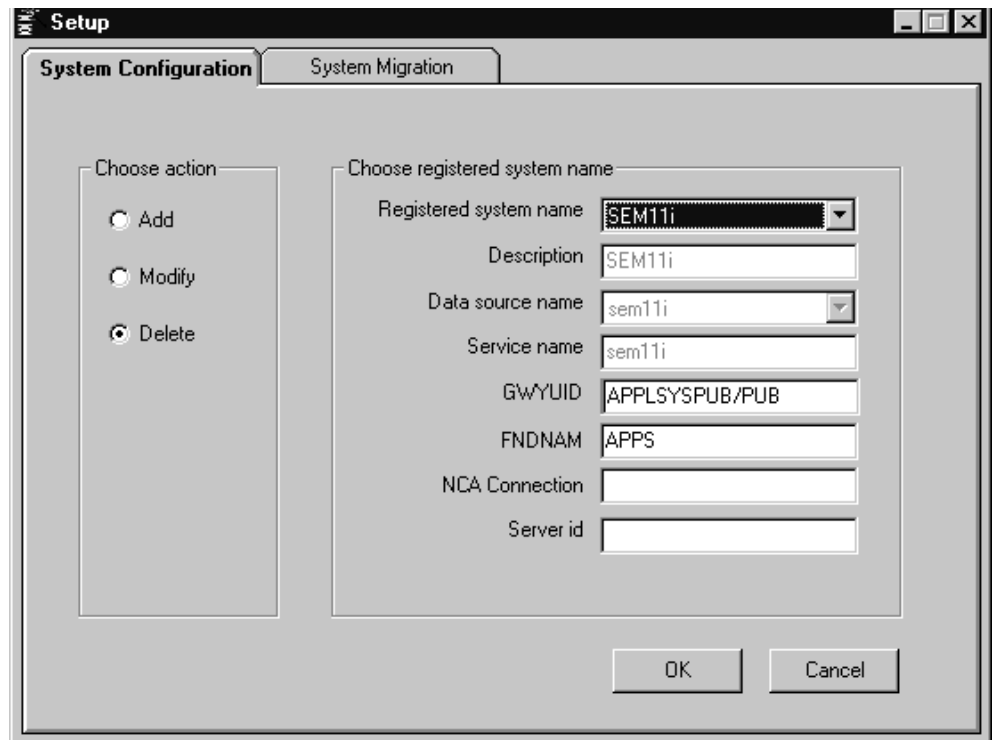

►► **To delete a registered system name:**

1. Select the Delete radio button.
2. From the System Name drop down list, select the System Name you wish to delete.
3. Click OK to delete the system

Upgrading a System from a Previous Version

If you already have a BSC system running in an Oracle 8 database, you can install BSC Architect for Release 11i.6 and navigate directly to the upgrade function. For more information, see [Upgrading to a New Version](#) on page 2-12.

To upgrade, you must first register your system using the new BSC Setup for Release 11i.6. In order to do this properly, you must first complete all the steps as outlined in the *Oracle Balanced Scorecard Install Guide*. Then, complete these steps:

1. Verify the service name and data source name using Oracle 8.0.6 utilities and 8.0.6 ODBC driver.
2. Register your system in the System Configuration tab.
3. Upgrade the system.
4. Migrate the upgraded system to an Oracle Applications database.

If you have a .dmp file from a previous version, such as version 1.5, complete these steps:

1. Import the system.
2. Upgrade the system.
3. Migrate the upgraded system to an Oracle Applications database.

Importing a System

Importing a system lets you import a .dmp dump file from a previous version to another schema that can be upgraded and then migrated to an Oracle Applications database. The .dmp file must have been created by the export feature to ensure compatibility. When importing, everything in the .dmp file, including any actual data that may have been included in the original system, is imported.

Note: This functionality is only available for the purpose of importing and upgrading an existing system from a previous version. To perform the import, you must connect to the source system database which is a non-Oracle Applications database. Once connected, the tabs for Import and Upgrade are enabled. Once imported and upgraded, you can migrate the system to an Oracle Applications database.

Figure 2–6 Import Tab

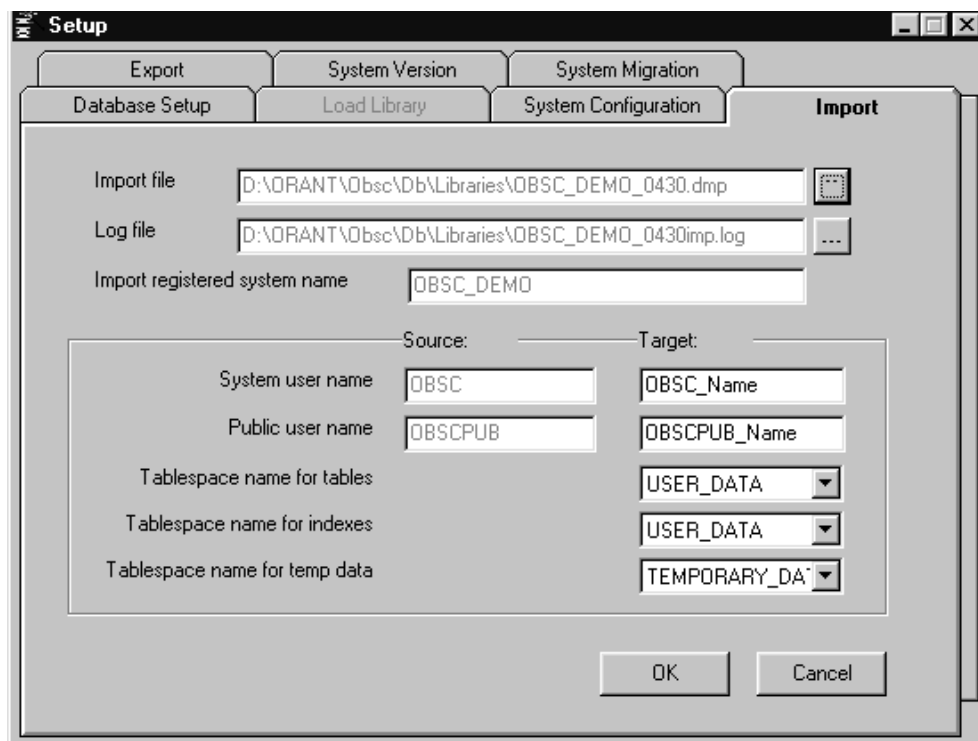

Note: To login to BSC Setup for importing and upgrading purposes, use SYSTEM/MANAGER as the user name/password instead of the default APPLSYSPUB/PUB.

►►To import a system:

1. In the Import File text box, select the .dmp file you wish to import using the square to the right of the field. When you select the file, most of the fields on the screen will be automatically populated:

Log File: Lists the log file that will be generated by the import utility. You may change it by clicking on the square to the right of the field. The log file will save all the information of events that occurred during the importing process. To interpret this file in case of errors, consult your system administrator or *Upgrading Oracle Applications*.

Import Registered System Name: Shows the System Name you are importing. The System Name refers to the BSC source system name which was exported.

Note: You cannot use a directory or file name that has a space in it. For example, the directory "d:\Log File" is not acceptable, but "d:\log_file" is.

2. In the Source-Target area, all the fields on the Source side will be populated automatically. You have to populate the Target side with appropriate schema names. Please provide the following schema names for this system:

System User Name (OBSC schema)
Public User Name (OBSCPUB schema)

3. You will also have to provide the correct tablespace names for tables, indexes and Temp data.
4. Click OK when you have finished completing all the fields to run the Import process.
5. When the import process is finished you will be prompted to provide a Registered Name. The Database Setup Wizard will also display a dialogue informing you of the log file location and its name.
6. The new imported system can now be accessed.

Note: If a system by the same name already exists, Setup will ask if you want to overwrite the existing system. Choose Yes to completely replace the old system.

Upgrading to a New Version

You must perform this step if you have a system in a previous version that you want to migrate to your Oracle Applications database. To upgrade your system, you must connect to your original source system database (for example, Oracle 8.0.4) and register your system using the new version of BSC Setup for Release 11i.6. Before you upgrade:

1. Verify the service name and data source name using Oracle 8.0.6 utilities and 8.0.6 ODBC driver.
2. Register your system in the System Configuration tab.

For example if you have a system previously created in version 1.5 and you want to work with this system in the new version, you must first do an upgrade selecting the setup System Version tab and the system to upgrade. The left side of the System Version tab lists the System Version and lets you upgrade your system. The right side lists the version of each application component installed on your computer. If your versions are identical the Upgrade button will be disabled.

Figure 2–7 System Version Tab, 1.5 to 4.0

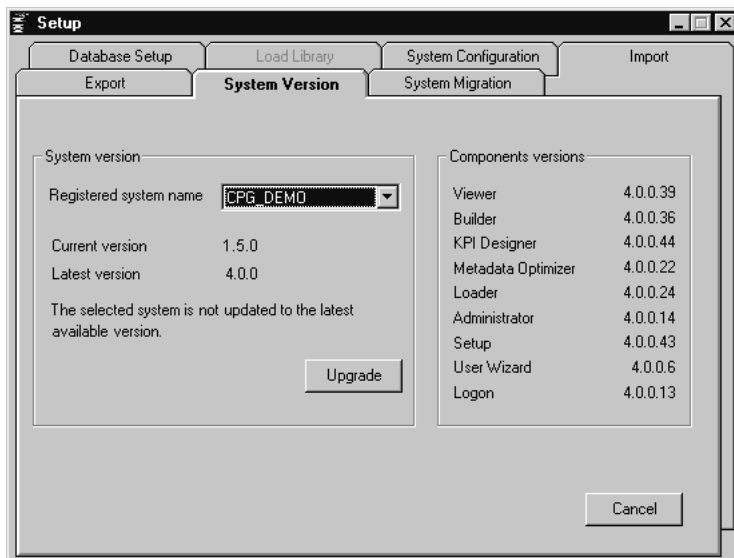

Note: This tab is enabled only when you connect to your source system database to perform the upgrade. Once the upgrade is complete, you can migrate the system to an Oracle Applications database, and you will no longer require this utility.

Note: If you are using a temporary 8i database to perform your upgrade and migration to Applications and if your non-applications database system contains a considerable number of tables and columns per table (more than 100), you may want to review the Oracle 8i block size. The right definition for these type of systems is "db_block_size=8,192". For more information consult your Oracle 8i documentation.

Figure 2–8 System Version Tab, 4.0 to 4.0

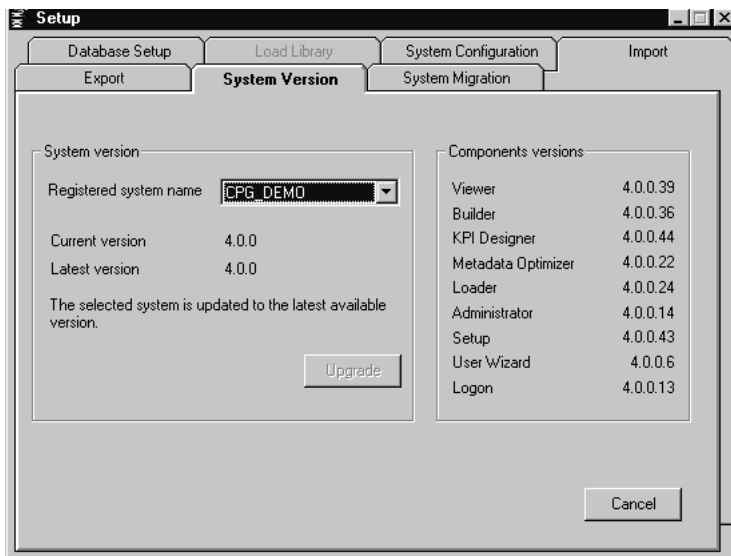

►► To upgrade the system version:

1. From the Registered System Name drop-down list, select a system to upgrade. You are asked for your user name and password. You are required to use an administrator level password. The password for systems in previous versions is BSCADMIN for both user name and password.
2. The Current Version field displays the version of your system. The Latest version field indicates the version of your BSC application currently installed. The two versions should match for BSC to function correctly.

3. If the current system version is less than the Latest version, you must upgrade your system.
4. Click on the Upgrade button to upgrade your system. You will receive a message indicating the upgrade has finished successfully.

Note: You are not able to upgrade an Apps database using the Setup wizard. This is done through the Oracle Applications environment. For more information, see *Oracle Applications Administration Guide*.

Once you have upgraded and migrated the system to an Oracle Applications database, you will not use this upgrade utility again. All upgrades in Oracle Applications are managed through patches. For more information, see *Oracle Balanced Scorecard Install Guide*.

Migrating a System

System migration lets you migrate data, system tables and metadata from a source system to a target system. You can specify three ways to migrate data:

- **All System:** Use this option to migrate the entire system (all tabs and all KPIs accessible to the source responsibility) to the target system.
- **By Tab:** Use this option to migrate only KPIs belonging to specific tabs accessible to the source responsibility. For example, you may want to migrate KPIs on the Operations, Quality and Sales tabs, but not the KPIs on the Finance or Marketing tabs. You can only migrate data that is accessible to the source responsibility you choose.
- **By KPI:** You can go directly to the KPI level by specifying specific KPIs. Again, the source responsibility you specify must have access to the KPIs you want to migrate. For instance, if the Chief Financial Officer only has access to the KPIs for Market Share, Sales Volume, and Unit Price, only those KPIs will migrate to the target system.

In both cases, to migrate everything at once, use the Administrator responsibility, which has access to all KPIs, as your source responsibility. When you perform a system migration, all data in the target system is **overwritten**. The KPIs in the target system appear in the same tabs with the same dimensions and data set configuration as the source.

Several restrictions apply in a system migration:

- ❑ Before you perform a migration, both the source and target systems must already exist. This means that both source and target systems must contain all system objects required to run the system. This includes Metadata tables, views, sequences, synonyms, packages and so forth. A database link must also be created before migration can occur (see "Creating the Database Link" on page 2-16).
- ❑ You must always execute the system migration from the target database. In other words, to perform the migration, you connect to the target database, and the migration process pulls data from the data source.

Note: Be completely sure that when you run the Migration process there are no other users connected or using the source system. If you find problems because there are other users connected or using the system, they must logout the source system and you also will have to logout the Setup and login again to be able to run the process properly.

Creating the Database Link

Before the user can execute the migration, the System Administrator must create the database link by doing the following steps:

1. Open SQL plus.
2. Connect to the target system. Since the target is an enterprise database that connects to the APPS schema, type the following:

```
connect Apps/Apps@Appsschema
```

3. Run the script bscsdbl.sql. This script is located in the BSC home directory (for example, d:\ORANT8i\OBSC\DB\Admin\sql). To run the script, login with the user name \password SYSTEM\MANAGER and, using the schema name, password and service name of the source system, execute:

```
@ d:\ORANT8i\OBSC\DB\Admin\sql\bscsdbl.sql <schema name> <pwd> <service name>
```

As previously noted, this script asks for the schema name, password and service name of the source system. The database link to the source system is called BSC_SRC_DBLINK.

Performing the Migration

►► To perform a system migration:

1. Log in as the BSC Administrator and select the System Migration tab to bring it forward.

Figure 2–9 System Migration Tab

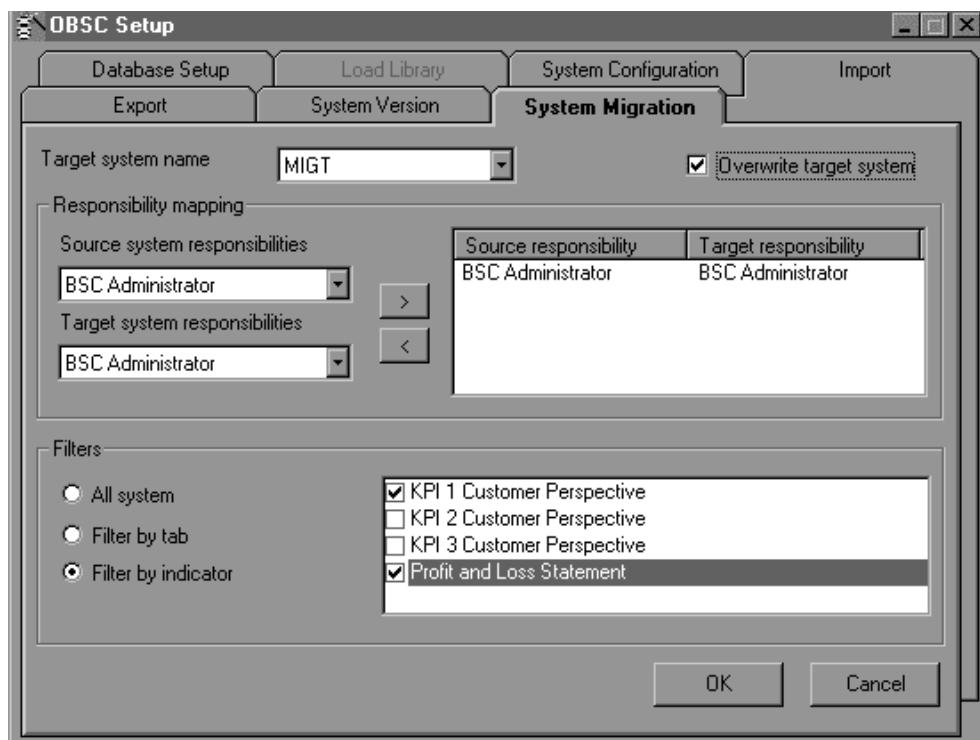

2. Select the target system from the Target System Name pull-down list. The system prompts you for a user name and password. Enter both and click OK.

Figure 2–10 Target System Name List



- Use the Source and Target System Responsibilities pull-down menus to select one or more responsibilities to map. As you select each responsibility you wish to map, click the (>) button to assign your mapping. You can map multiple source responsibilities to one target responsibility; one source responsibility to multiple target responsibilities; or a single source responsibility to one target responsibility. The migrated KPIs are assigned to the target responsibilities in the same way that they are assigned to the corresponding responsibilities in the source system.

Figure 2–11 Responsibility Mapping Frame

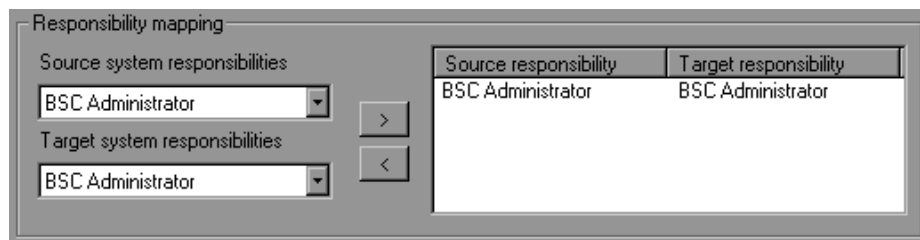

- Choose a filtering method from the radio button list. You can filter the whole system, by tab (scorecard) or by indicator. If you select Filter by Tab or Filter by Indicator, a list of tabs or KPIs accessible to your chosen source responsibility appears in the Filters pane. Use the check box beside each KPI to select those you want to migrate.

Figure 2–12 Filters Frame

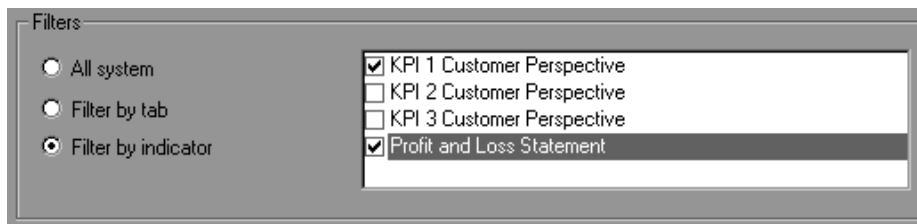

- Check the Overwrite Target System box. This ensures that migration will occur. If you do not check this box, nothing will happen; the purpose of the box is to alert the user that system data will be overwritten.

Figure 2–13 *Overwrite Target System Check Box*

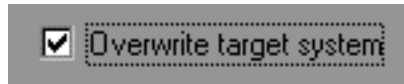

6. Click OK. The source system migrates to the target system.

Database Setup and Export

The Database Setup Tab and Export Tab in the BSC Setup are required only for consultants who may not have access to an Oracle Applications database, and may need to work with a temporary schema during the design phase using BSC Architect.

Note: All functionality in Release 11i.6 works on top of an Oracle Applications Database environment. The only steps where you may be required to connect to a Non-Oracle database would be when you Import and Upgrade a previous version system. When you upgrade a previous version, the Import and System Version functions would be available as an intermediate step to migrate to Applications Environment; however, other functions such as Database Setup and Export will be visible, but not required under the Applications environment.

BSC Builder

When creating a new system, the BSC Builder wizard will guide you through a process that helps you to complete the basic steps to configure your scorecard structure and define the system properties before going to KPI designer to configure the different indicator details.

In this process you basically:

- Define general system properties including system name, system images and general currency.
- Create a scorecard structure, adding the main groups with their correspondent indicators.
- Define different scorecards for the organization.
- Add indicators to one or multiple scorecards.
- Define other properties per scorecard such as filtering or common dimensions views.

Defining General System Properties

When you define general system properties, you can edit the system name, configure system images, and define a system currency.

Editing System Name

You can rename your system from BSC Builder by editing the existing name appearing in the first line of the BSC Builder window.

1. Right-click on the highest level node in the target system hierarchy (right panel). The name of the node is selected.

Figure 3–1 Renaming the Default Template and Groups

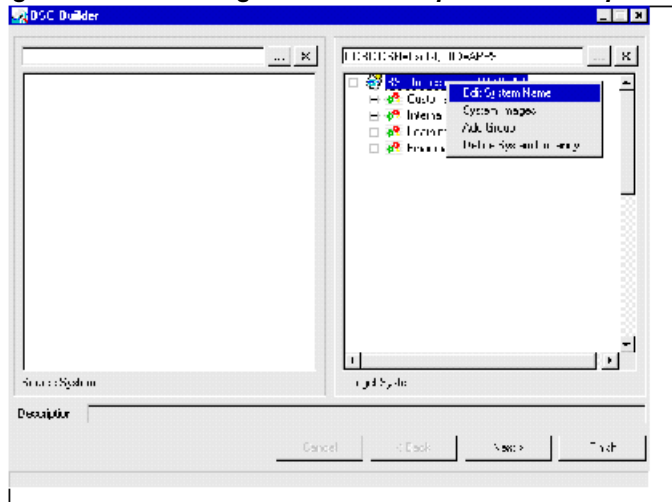

2. Select Edit System Name from the pop-up menu. A cursor appears at the end of the system name, showing that the title can now be edited.
3. Enter a new system name and click Enter. The name must be 20 characters or less. The new name now appears on the target system hierarchy.

Configuring System Images

Using the Builder, you can include system images into your system. You can import a company logo image that you will see in both design mode and in the Viewer.

►► To configure the company logo:

1. Right click on the system title in the Builder. The system title is located directly above the names of the groups in the Builder.
2. From the pop-up menu, select System Images. The System Images window is displayed.

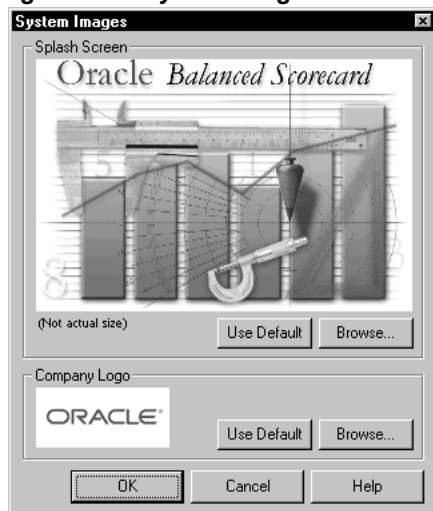
Figure 3–2 System Images Window

3. To change the company logo, click on Browse from the Company Logo frame and select a valid image file, such as a .jpg or .gif file. The optimal size for the image is 340 width x 100 height.

Note: The Company Logo image must be either a GIF or JPG file. These are the only image file types supported in this version.

4. Click OK to save your changes.

Note: If your logo is bigger than the specified size, the application can accommodate the picture on the screen taking space reserved for other elements on the graphs or views.

Defining System Currency

You can define in BSC Builder the type of currency you want to use for the system. Since this is a general property, the currency symbol you define here is going to affect all indicators and measures defined in the system.

To define the currency symbol, do the following:

1. Choose Define System Currency function.

Figure 3–3 Define System Currency

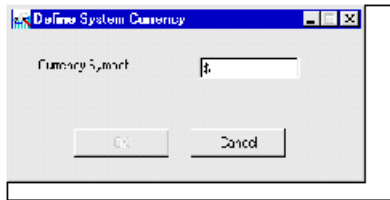

2. In the pop-up window, enter the currency symbol you want to use for your system.

Note: A valid currency symbol can have up to four characters as a maximum.

3. Click OK to save your changes.

Creating and Modifying Groups

The first step in building a scorecard structure is to define a target system hierarchy. The hierarchy contains a nested web of groups, each containing a set of indicators. You can have different types of indicators in each group. When you first open Builder you see a template with sample groups and sample indicator names:

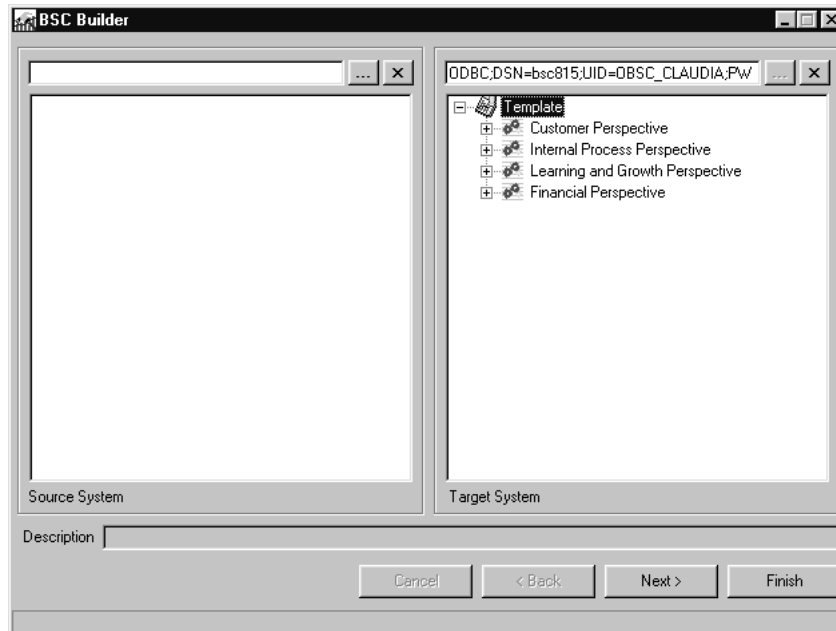
Figure 3–4 *Template With Sample Groups*

The first time you launch the Builder, the Source panel (left panel) is blank. In the Target panel you see the hierarchy for a template target system. To rename a new target system, rename the template and use the sample indicators and groups as desired.

Once you have named your target system you can start adding groups. A group can represent a balanced scorecard group or any type of user-defined grouping you find appropriate for the given balanced scorecard (such as strategic objectives). You can either use the groups provided with the template or create new groups.

▶▶ To create a new group:

1. Hold down the right mouse button on the system title.

Figure 3–5 New Target System

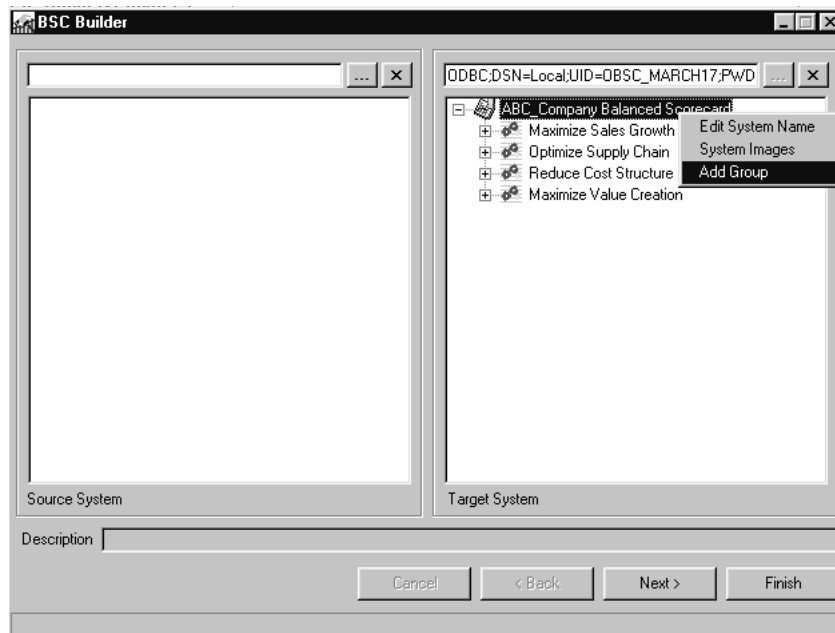

2. From the pop-up menu that appears, select Add Group. A new group appears at the bottom of the list.
3. To edit the title of the new group, highlight the group title and hold down the right mouse button.
4. From the pop-up menu, select Edit System Name. A cursor appears at the end of the group name indicating that the title can now be edited.
5. Enter a new group name and click Enter. The group name now appears in the target system hierarchy.

Editing Group Properties

Group properties define the layout of how a group appears in the balanced scorecard window. Use the Group Properties window to arrange the alarm boxes in relation to the indicator titles, and to specify where the group title appears in relation to the box containing the group's indicators.

▶▶ To edit a group's properties:

1. Highlight the selected group and hold down the right-mouse button to display the pop-up menu.
2. Select Group Properties. The Group Properties window appears.

Figure 3–6 Group Properties Window

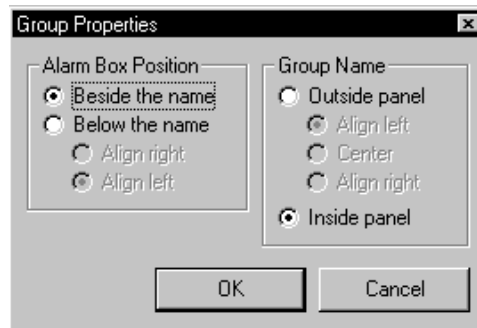

3. In the Alarm Box Position panel, click a radio button to specify where you want the alarm boxes to appear in relation to the group's indicators.



WARNING: When you choose "Below the name" for the Alarm Box Position, you can have only one indicator in that group.

4. In the Group Name panel, click a radio button to specify where you want the group title to appear in relation to the panel box.
5. Click OK to save your changes, or Cancel to cancel and restore the default settings.

Removing Groups

Groups can easily be removed from the system, but it's important to consider the design implications before doing so. Deleting a group causes any indicators or data associated with the group to be removed permanently from the database. If the group you wish to remove does include indicators or data that you wish to keep, then you may want to relocate the indicators to another group before removing the group from the system.

►► To remove a group:

1. Delete KPIs belonging to the group or relocate them.
2. Hold down the right mouse button on the group name.
3. From the pop-up menu, select Delete Group. A dialog box appears asking, "Are you sure you want to delete [your group name here]".
4. Click Yes. The group is removed from the hierarchy.

Using a Source System

If you plan to copy KPIs from a source system, you'll need to install and identify a source scorecard or library. You can open several different sources if necessary. To do this, locate the first source and copy the required KPIs. Then, locate the second source and again copy KPIs. Continue loading sources and copying elements, till you have copied all the required KPIs.

Note: You can only have one schema per database; therefore, ensure that your source or library systems is in a separate Oracle Applications instance.

►► To select a source library or scorecard:

1. Open the Builder main window.

Figure 3–7 Source System Window

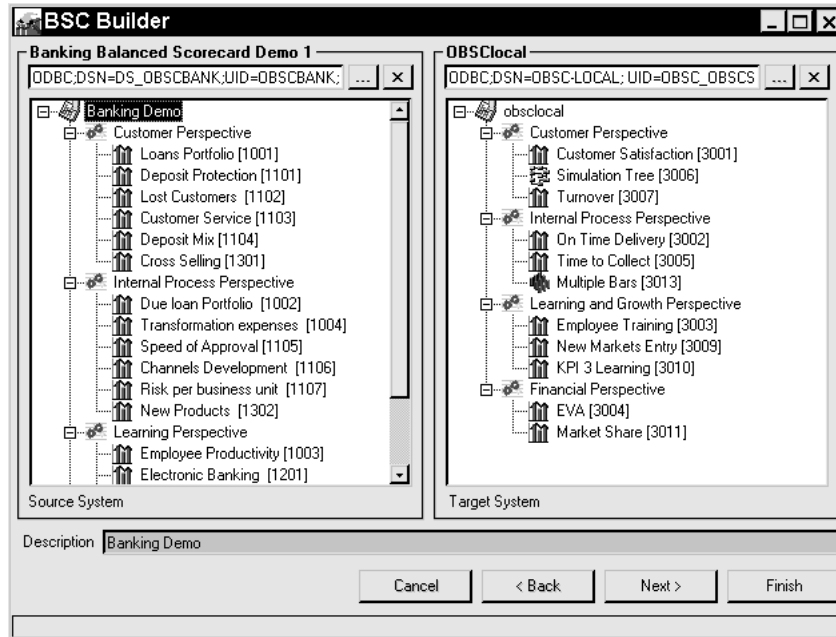

2. At the top of the Source System panel, click the browse button. If source libraries or scorecards have been installed, an Open Project window appears.
3. Select a scorecard or library, then enter the User Name and Password for the source system. The hierarchy of the selected source now appears in the Source System panel.
4. In the Source System panel, highlight the indicator you wish to copy by clicking it with the left mouse button.
5. Hold down the left mouse button and drag the indicator from the Source panel to the desired group in the Target System panel.

Creating Indicators and Defining Indicator Properties

Key performance indicators are the basic informational units of the balanced scorecard. Indicators may represent critical success factors or organizational objectives. In the final balanced scorecard, each KPI will have its own indicator window with data display and data analysis options, which are typical analytical metrics related to the indicator objective.

Once the groups have been created, you can start creating indicators associated to each group. There are four different types of indicators:

Table 3–1 *Indicator Types*



Single Bar Indicator: This indicator is used to represent a single data series. It usually presents a historical trend (one bar across time) compared to one or multiple benchmarks represented in lines.



Multiple Bars Indicator: This indicator is used to display multiple series of data across time. Although the default mode is bar, this type of KPI can display multiple series of data in bars, lines or areas. Use a multiple series KPI when you wish to break out indicator data into subcomponents. For example, if the KPI is “Customer Deposits”, a multiple series KPI might display separate series for “Checking”, “Savings” and “CDs”.



Simulation Tree Indicator: This type of indicator is used to perform “what-if” analysis. A simulation tree allows scorecard users to simulate the impact of changes in leading analytical metrics into lagging analytical metrics. The simulation tree indicator can be a powerful tool for data analysis and strategic planning.



Profit and Loss Indicator: The P&L Indicator displays accounts in the form of horizontal bars to provide the user with a graphical view of what accounts contribute to revenues, and what accounts consist of expenses. The bottom-most horizontal bar shows the total of revenues - expenses to show profits or losses.

►► To create a new indicator:

1. In the Target System panel, hold down the right-mouse button on the group title.
2. From the pop-up menu that appears, select New Indicator.
3. From the New Indicator sub-menu select one of the following options:
 - Single Bar
 - Multiple Bars
 - Simulation Tree
4. A new indicator appears within the designated group.
5. To edit the title of the new indicator, hold down the right mouse button on the indicator title. From the pop-up menu, select Edit Caption. A cursor appears at the end of the group name indicating that the title can now be edited.
6. Enter a name and click Enter. The group name now appears in the target system hierarchy.

Special Note About P&L Indicators

1. One sample P&L indicator comes with the initial template that appears the first time you open BSC Builder. If you are planning to use a summary of your Profit and Loss in the scorecard, do not delete this indicator from your template.
2. Administrators can either use this indicator or delete it if they don't want to use it.
3. New P&L indicators cannot be added. However, you can use the Builder to copy an unlimited number of additional P&L indicators into the system from other BSC systems or duplicate P&L indicators (copied from the same system).
4. These indicators can then be modified by the administrator upon request.

Copying KPIs Between Groups

You may copy a KPI from one group to another in the Builder.

►► To copy a KPI:

1. Click on the KPI to highlight it.
2. Drag the KPI to the new group you wish to put it under (the new group's name will be highlighted) and let go.
3. Select "Copy Indicator" from the pop up menu that comes up.
4. Next you will have to map entities that exist on the KPI you just copied to the various entities defined in the BSC system. These entities include dimensions, dimension groups, and Data definitions (datasets). If dimensions cannot be mapped, new dimensions may be created in the BSC system or you may use the default options.
5. To help you map dimensions, the Builder will display the Dimensions Mapping window.

Figure 3–8 *Dimensions Mapping Window*

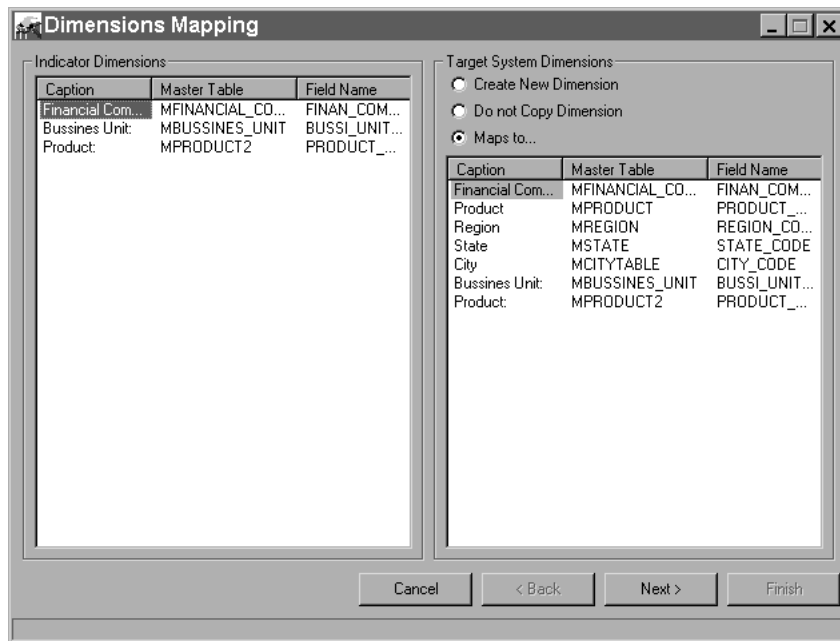

6. The right panel of this window shows the dimensions defined in the KPI you are copying. The left side shows all dimensions defined in the system. Using this dialogue you have to map each of the KPIs dimensions to a system dimension. Note that if you are copying a KPI within the same system, all KPI dimensions will already be defined as system dimensions, and the system will recognize this.
7. To map a KPI dimension to a system dimension: Highlight the KPI dimension you wish to map on the left panel, and then highlight the system dimension on the right side that it maps to. Continue with each KPI dimension until all have been mapped. While doing this, make sure the "Maps to..." radio button is selected at the top right of the screen.
8. If the KPI dimension you have highlighted does not map to a current system dimension you may create a brand new system dimension. Simply select the "Create New Dimension" while mapping dimensions. The Builder will ask you for the name of the new dimension later in the mapping process, and will create the dimension.
9. You may also select not to copy a KPI dimension. If this is the case, when you have the KPI dimension that you don't want copied highlighted, make sure you select the "Do Not Copy Dimension" radio button. The dimension will not be copied.
10. After you have selected all the dimension mappings, click Next.
11. You will next have to map Dimension Groups and Data Definitions (also known as Datasets). Follow the same procedure as in steps 7-9, above.

Moving KPIs

Moving KPIs is similar to Copying KPIs, above. Simply follow steps 1 and 2 above but when the pop up menu comes up select "Move KPI". The KPI is moved to the new group and no mappings have to occur.

Creating Tabs for Custom Scorecards

Once the required groups and indicators have been created in the Builder main window, click the Next button to begin creating and editing tabs to which indicators and groups will be assigned. Any groups or indicators you created or modified in the main window will be listed on the tabs.

Figure 3–9 Builder Tabs Window

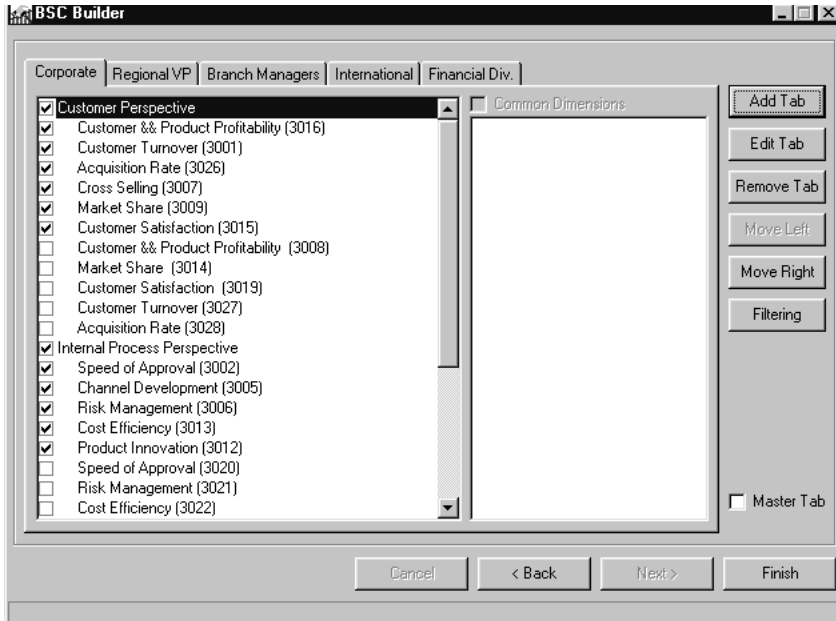

Each tab is an individual scorecard that typically represents a particular organizational role or division. The design of tabs depends on the business structure and how you want to present different sets of indicators to different organizational units. For instance, one tab may contain a Corporate scorecard with a complete set of indicators for the organization, while other tabs may contain subsets of KPIs or KPIs relevant for a particular division or unit.

Be aware during the design process that in the actual implementation, you can define security by tab and by KPI. This may affect the number or organization of tabs you create.

Key performance indicators are classified into groups which represent organizational perspectives or strategic objectives. These groups include the title of the strategic objective associated with the enclosed indicators.

Note: The tabs or scorecards created in BSC Builder will be displayed in BSC Architect in the same way. However when you use the BSC Viewer the graphic interface does not display tabs. The scorecards created in this step are represented in your List of Scorecards window in the BSC Viewer.

▶▶To create and edit a tab:

1. If you are creating a new tab, click the New Tab button. If you wish to edit an existing tab, click the tab to bring it forward and then click Edit Tab. In both cases, the Tab Properties window appears.

Figure 3–10 Tab Properties

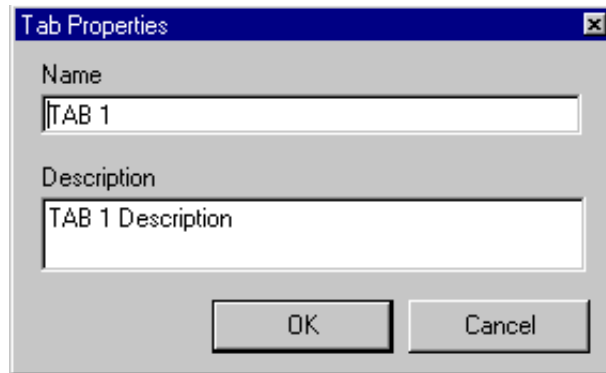

2. Enter a title for the tab in the Tab Name field. Because this is the title that appears on the tab itself, it's helpful to keep it brief.
3. Click OK to save your changes, or Cancel to cancel.
4. Select the groups and KPIs that should appear on the tab by checking the appropriate indicator checkboxes.
5. Continue creating and editing tabs as required by the Balance Scorecard specification.
6. When you are done, click Finish to save your changes.

▶▶To change the tab order:

1. Activate the tab you wish to move by clicking on it and ensuring it shows on top of the other tabs.
2. Click the Move Left or Move Right buttons to move the selected tab left or right.

Assigning KPIs to Tabs

If you have more than one tab, you can assign KPIs to individual tabs by selecting and deselecting them in the tab window. To have a KPI show up on a tab, ensure that it is selected by placing a checkmark in the box to the left of the KPI name.

Please note that you must assign each KPI to at least one tab (you cannot leave any unassigned KPIs), and only master KPIs can be assigned to more than one tab (see "Master and Shared KPIs" on page 3-16). If you only have one tab, all KPIs in the system must be assigned to that tab.

When a KPI is checked in multiple tabs, it is assigned a new number but retains the name and number stamp of the master KPI. Groups can also be selected and deselected from tabs. If you wish to remove a whole group from tab you must first deselect all the KPIs underneath that group.

Types of Indicators

- Normal KPI: A KPI specific to one tab that does not need to be shared with any other tab. If a KPI is not to be shared among tabs, make sure it is *not* selected in the Master tab.
- Shared KPI: A KPI assigned to more than one tab.
- Master KPI: A KPI on which shared KPIs can be based. If a KPI is to be shared among tabs, it must be defined as a master KPI.

Master and Shared KPIs

While many KPIs belong logically in only one specific tab, there may be instances where you wish to *share* KPIs between and among tabs. For instance, there are cases where you will want a KPI to be visible to different organizational units with small variations in its view but the same overall meaning and purpose. These variations could be analytical dimensions or metrics that are emphasized in one case but not another.

Rather than copy and recreate the same indicator in different tabs, Builder allows you to *share* a master indicator that can be customized in different views - hiding or exposing options that are relevant for a particular tab but not for another.

A shared indicator is a copy or mirror of a master KPI, retaining the structure of the master but with a view that can be reconfigured. While the variations possible on a shared KPI are not structural, it is possible to define a different view of dimensions, periodicity, analysis and/or calculations by tab.

For instance, you may choose to create a master KPI for Sales Growth, with the goal of using it in multiple tabs representing different organizational units. Using a shared KPI, you could emphasize different dimensions for Marketing personnel (for instance, Distribution Channel and Customer Type) than for a Regional Vice President (for instance, Region and City).

Builder only allows the definition and selection of normal, master and shared KPIs. The actual configuration of the KPI - its analysis options, dimensions, calculations, periodicity and benchmarks - happens in KPI Designer (see: "Analysis Options").

Creating Master or Shared KPIs

Before defining a KPI as a master KPI, ensure that you are as close as possible to defining your entire set of KPIs for all tabs. You can create KPIs by copying predefined ones from libraries or other BSC systems, or by copying indicators from the same system into another group. If this is not done before master KPIs are defined, it can complicate the task of ensuring consistency with each indicator. For instance, any tab that contains indicators created *after* defining the master KPIs and tab may have to be reconfigured in other ways.

►►To create a master or shared KPI:

1. Whether your objective is a master or shared KPI, begin by creating or copying indicators and groups as described in "Creating and Modifying Groups" and "Creating Indicators and Defining Indicator Properties".
2. Use the Master check box to define one tab as the Master tab. After choosing a Master tab and selecting indicators in this tab, you will be able to share indicators in other tabs.

Figure 3–11 Master Tab Selected

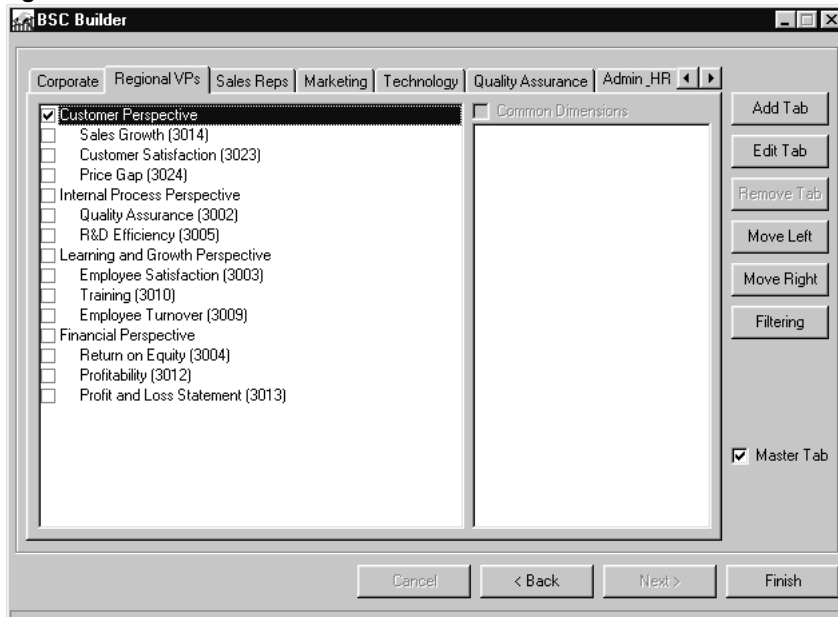

3. Check the box beside all KPIs you wish to share between tabs. In Figure 3–12, Sales Growth, Customer Satisfaction and ROE are selected in the Master tab. This exposes those KPIs for selection in the Sales Reps tab as shared KPIs:

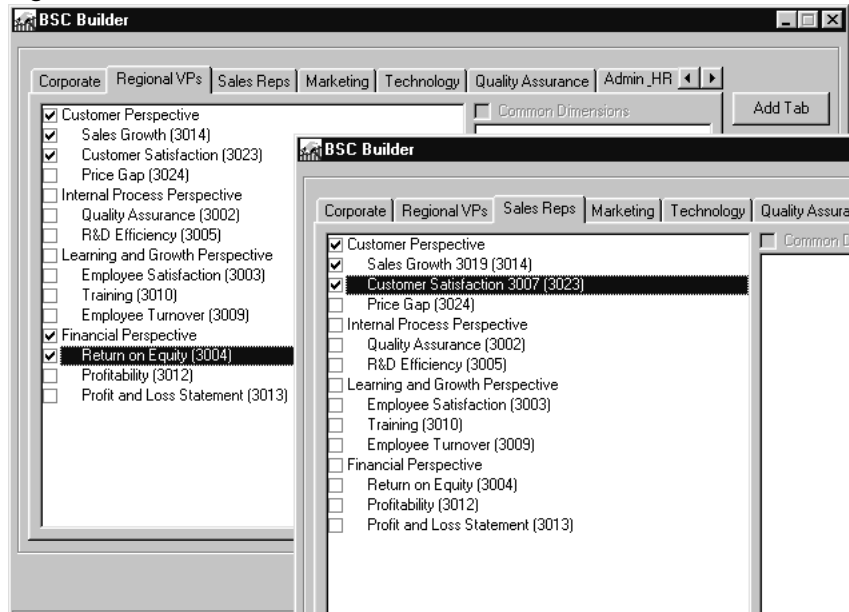
Figure 3–12 Shared KPIs Selected in Tab

4. Individually, click the label of each tab in which you want to share a master KPI and select that KPI by clicking its check box.
5. While each shared KPI is assigned a new number, it retains its master number. For instance, in the Sales Rep tab below, both the Sales Growth and the Customer Satisfaction KPI have two number stamps: one for the master KPI, and one for the shared KPI.

Figure 3–13 Shared KPIs With Two Number Stamps

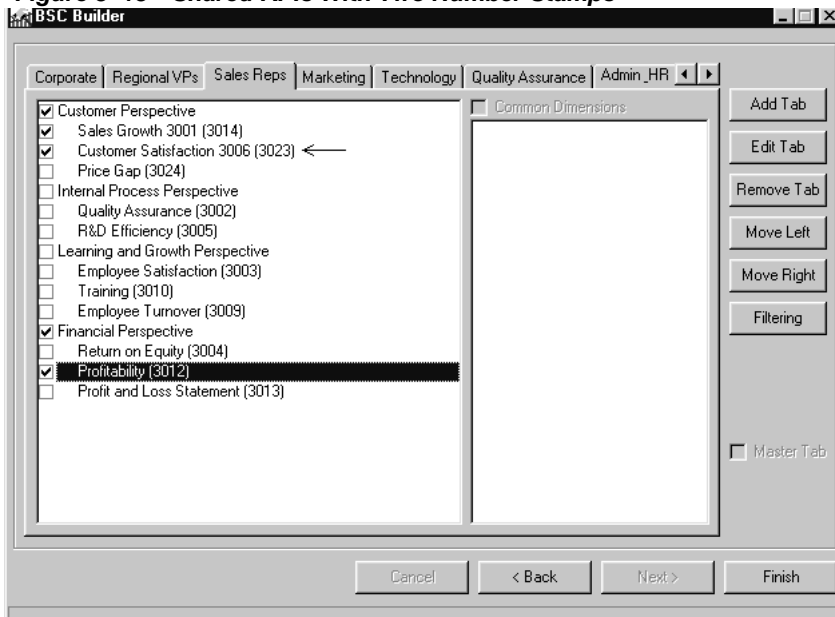

►► To change a master KPI into a normal KPI:

1. Unassign the KPI from all tabs where it is selected
2. Unassign the KPI from the Master tab
3. Assign the KPI to the preferred tab (for more information on assigning KPIs to tabs, see "Assigning KPIs to Tabs" on page 3-16).

►► To rename a master KPI:

1. Go to the main screen of BSC Builder.
2. Click the name of the KPI you wish to modify, then hit F2 to modify its name.
3. Builder synchronizes the changes across all tabs containing that KPI.

►► To delete a master KPI:

1. Deselect it from all tabs where it is shared
2. Return to the first screen of BSC Builder
3. Right-click on the indicator
4. Choose "Delete Indicator."

Effect on Input Tables

One of the main purposes of the master/shared KPI structure is to optimize the number of input tables in BSC. If an indicator is copied rather than shared, Metadata Optimizer generates multiple tables, requiring the user to populate data in more than one table and likely duplicate data between tables. With the master/shared KPI structure, input tables are shared, minimizing duplication of effort and time and data replication.

In the case of precalculated KPIs, Metadata Optimizer will optimize the tables so that input tables for common datasets are shared across KPIs with the same dimension configuration. As a result, if the user configures master and shared KPIs to show different views of the KPI in different tabs, this may reduce the number of tables, thereby reducing data entry overhead for each KPI.

Note: If the user creates a shared KPI using a master that was in production mode (i.e., already contains data), the user needs to rerun Metadata Optimizer and BSC Loader on the input table that feeds the master KPI. This is done to make sure the shared KPIs show the updated information and color.

Note: Be aware that every time you modify a master KPI every shared KPI will be affected with the change. This is especially important when you configure your master and shared KPIs in KPI Designer. For instance if you add or delete dimensions, add analysis options, add datasets, etc, all the shared KPIs depending on this master are going to be refreshed. This means previous changes done to shared KPIs are reset based on the master modifications.

Using the List Button

When activated, the List button appears on the bottom right of a balanced scorecard main panel in Design mode, next to the Exit button:

Figure 3–14 List Button



Once configured, the List will appear as a "View By" option in the Viewer for all of the main views that are defined, including Scorecard View, Strategy Map View, and others. The List button is used to "filter" the main panel of a BSC system by different dimension values. For example, suppose the alarm boxes for a corporate balanced scorecard have these values:

Figure 3–15 Main KPI View Without List Button Enabled

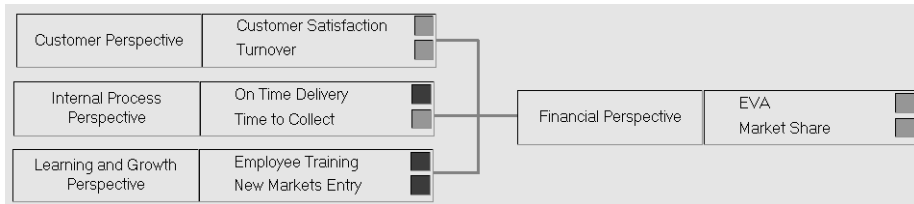

Using the List button, a user could view the same balanced scorecard, but for a specific dimension value. For example, if Region is one of the available dimensions, the South Region could have the following values:

Figure 3–16 Main KPI View With List Button Enabled

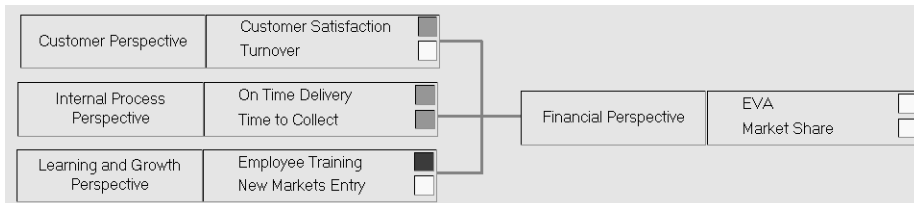

When a user clicks on the List button, they can see all of the valid dimensions by which their balanced scorecard can be viewed. In this example, several dimensions

have been set up by which the user can view the scorecard: Region, State, and City. The valid dimension values for the South region are shown below:

Figure 3–17 List Button Dimensions

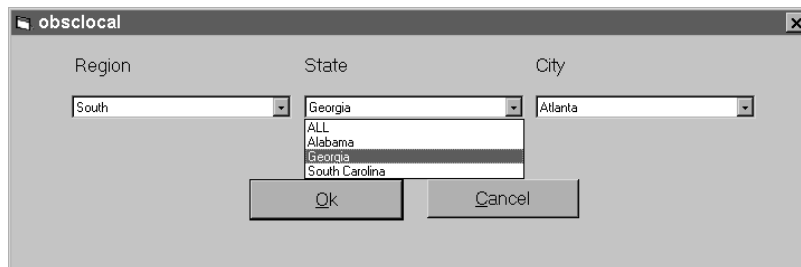

The user can choose any possible combination of dimensions and dimension values, being restricted only by the relevant parent-child relationships. (In the above example, the user could not choose a state that is not in the South region. The system automatically restricts this by allowing the user to only pick the valid children values, depending on the parent value they selected).

In this case the user has chosen to see the balanced scorecard for Atlanta, Georgia by selecting those respective dimension values. When the user clicks OK, the panel will display the alarm box values for Atlanta.

Using the BSC Administrator, a user could also be limited to a certain set of dimension values. If the above user was the Atlanta manager, they could be restricted to seeing only Atlanta data. If this was the case, the user's list button would be deactivated and the panel alarms would always be for Atlanta.

Additional flexibility could be achieved with the List button. If our user was the South manager, for example, they would have the Region dimension locked, but would be able to select any Southern state and city when clicking on the List button.

Additional List Button Functionality

It is important to understand that dimensions become available to the List button *only when they are common to every KPI on the tab*. If dimensions are not common to every KPI on a tab, you can filter using the Filter button (see "Filtering Dimensions by Tab" on page 3-27). For example, the Region dimension must exist on every KPI in the tab in order to become available to the List button. In the example used above, all three dimensions (Region, State, and City) exist on every KPI on the tab, this is why they are available as List button dimensions.

Since List button dimensions are identical to KPI dimensions, whenever a specific dimension value is selected using the List button, and then the user enters a KPI, that KPI will display only the data for the selected dimensions. For example, if the user doesn't choose any List button dimensions, when they go into the KPI, they will have all three dimensions List buttons available to use. In the example below, they are Region, State, and City. (Customer Type is an independent dimension).

Figure 3–18 KPI View, No List Button Dimensions Selected

The screenshot shows the 'Customer Satisfaction' KPI view. At the top, there is a header with 'Customer Satisfaction' on the left and 'ORACLE' on the right. Below the header is a search bar. Underneath the search bar are four dropdown menus labeled 'Region', 'State', 'City', and 'Customer Type'. Each dropdown menu has 'ALL' selected, indicating that all dimensions are currently available for selection.

However, if using the list button they select to see the South region, they will not have this dimension available when they return to the KPI. They will have the following dimensions:

Figure 3–19 KPI View, Region Dimension Selected in List Button

The screenshot shows the 'Customer Satisfaction' KPI view after the 'Region' dimension has been selected. The 'Region' dropdown menu is no longer present. Instead, there are three dropdown menus labeled 'State', 'City', and 'Customer Type', each with 'ALL' selected. This indicates that the KPI is now filtered by the selected region, and only the remaining dimensions are available for further selection.

Notice that the Region dimension is not available because the whole KPI is already filtered on the South region.

Setting Up the List Button

Setting up the List button involves both the KPI Designer and the Builder. Follow steps 1-2 in KPI Designer and steps 3-6 in BSC Builder.

►► To set up the list button:

1. Add dimensions to KPIs. Ensure that the dimensions you wish to add to the list button exist on every KPI on the tab. In addition, the dimensions must be in the same order (from left to right) on every KPI. To ensure this, you may want to

group List button dimensions in a common Dimension Group and Dimension Set in the Dimension definition window, and assign the group as a whole to KPIs. Dimensions with COMPARISON as their default value cannot be included in the list.

- List button dimensions must be related through parent-child relationships. Independent dimensions cannot be part of a List button configuration. For example Region, State, and City have a parent-child relationship and can therefore be part of a List button configuration. But Customer Type is an independent dimension from the three geography dimensions (any customer type can be in any region, city, or state); therefore Customer Type cannot be in the List button configuration. However, Customer Type by itself could be a List button dimension. Ensure that your selected dimensions have been defined with the proper parent-child relationships in Define Dimensions in the KPI Designer.

Figure 3–20 Dimension Relationships Window

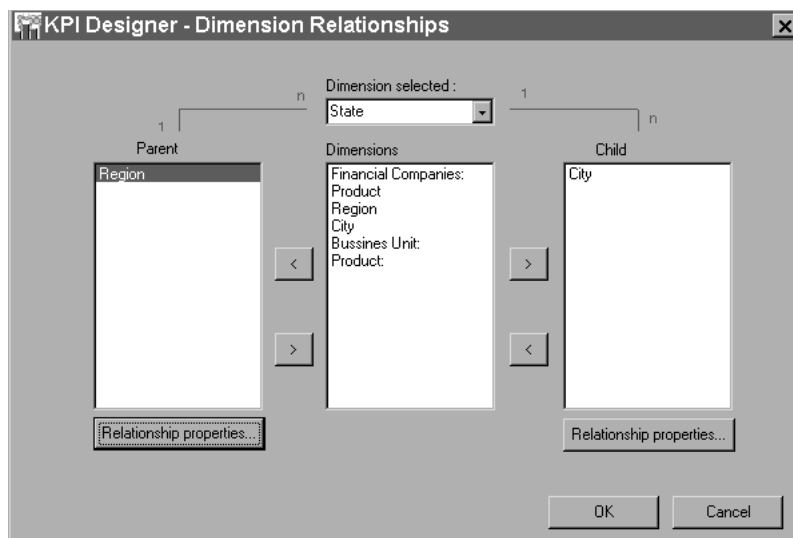

- After you have added dimensions to KPIs and defined the relationship between dimensions, go back to the Builder and go to the second window, where tabs can be defined and KPIs selected for each tab. Click the checkbox for the List Button, which is on the right side of the screen.

- When you click this checkbox you will see activated the possible dimensions that are available to the List button. These dimensions will be displayed based on meeting the following criteria: a dimension has to exist on all KPIs on the tab, it must be in a proper parent-child relationship, and it must always be assigned to a KPI in the same order, left to right, as the other dimensions.

Figure 3–21 *Tabs Window, List Button Activated*

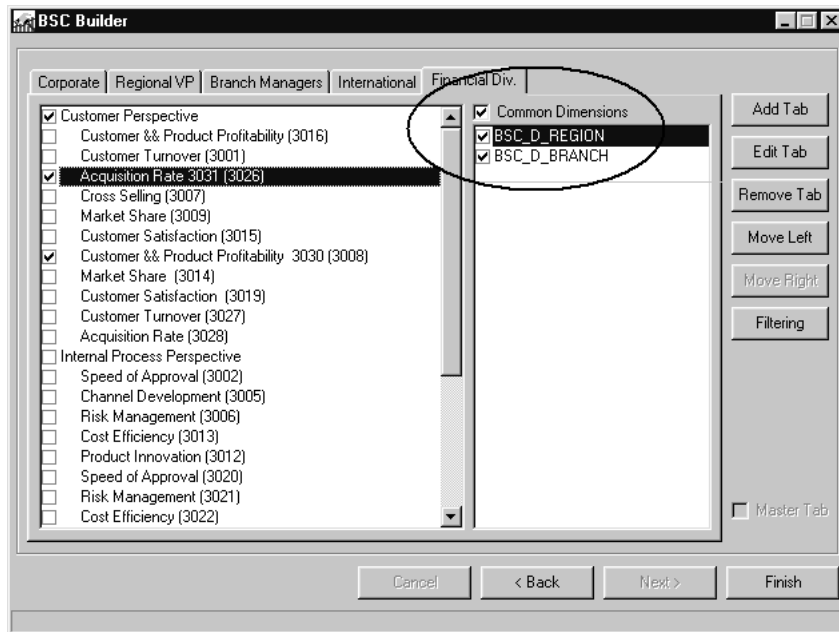

Note that the dimensions will be described by their dimension table name, and not by their given name.

- Select the dimension you would like to see in the List button configuration using the checkbox. You will notice that you cannot select a child dimension without selecting the parent first.
- Follow this procedure for all tabs that need the List button set up.

Note: If KPIs have different dimension sets defined by analysis option, all analysis options that modify dimensions must have the identical dimension configuration. Otherwise, the List button will not work.

Restrictions on Use of the List Button

- ❑ For dimensions to be available to the List button, they have to be defined as a parent-child relationship.
- ❑ An independent dimension cannot be part of List button dimensions, unless it is the only dimension available.
- ❑ The Parent dimension in a parent-child dimension has to be one of the List button dimensions.
- ❑ Parent-child relationships have to be one to many, not many to many. For example a state-city relationship is OK because a state can have many cities, and any one city belongs to just one state, but a state-products relationship is not because a product can be sold in many states, and a state can have many products.
- ❑ Any dimension used in the List button cannot be configured as a default COMPARISON dimension in the KPI. The user can manually select COMPARISON for that dimension, but the KPI cannot have that dimension as a default view (when the user first goes in). The KPI Designer will disable the List button if COMPARISON is selected on a dimension.
- ❑ List button dimensions have to be common to all KPIs, and they have to be in the same exact order on all KPIs. For example, if Region, State, City are the common dimensions, they have to be in this order on all KPIs in order to be available for the List button.
- ❑ List button relationships can only be defined from left to right on the KPI. For example: Region > State > City is OK, but Region > City > State is not.

Filtering Dimensions by Tab

The Filtering button lets you define which dimension values you want to see in each tab. The filter applied over a dimension in a tab affects all indicators using that dimension in that tab. This feature is useful when you want to show only a set of data for a particular dimension within a tab. For instance, on the Southwest

Division tab, you may wish to display only the regions, products, or other business dimensions belonging to the Southwest Division.

The main purpose of filters is to allow users to define different sets of dimension values for all indicators that belong to a tab. Typically, different tabs representing different organizational units may have different sets of products or geographies associated with them. As an example of filtering by the product dimension, while the Corporate tab may show all products, the Brewery Division tab may show only products relevant to its associated division (such as light beers), while the Soft Drink division tab may only show soft drink products.

Difference Between List Button and Filter By Tab

The List button and filter by tab features are similar but not identical. For instance, you can only filter one value with the List button, while using filter by tab, you can select multiple values per dimension. In addition, the restrictions that apply to the List button definition - i.e., the need for a common dimension across all KPIs in a tab - are not necessary for the filter by tab feature to function. Filter by tab can be applied to all KPIs using a selected dimension even if other indicators do not share this dimension.

Note: Generally, filtering a dimension by tab overrides the List button values. For instance, if you are already filtering by region (a dimension common to all KPIs in a specific tab), and a List by Region is defined, KPI Designer will display only data associated with the region being filtered.

To filter dimensions by tab, you will need KPI Designer, Metadata Optimizer and BSC Builder. Complete step 1 and 7 in KPI Designer, step 2 in Metadata Optimizer and steps 3-6 in BSC Builder.

►► To filter dimensions by tab:

1. First define all indicators, dimensions and dimension relationships using KPI Designer (see Chapter 4, "KPI Designer Wizard", section titled "Designing Data Dimensions").
2. Next, use Metadata Optimizer to configure dimension tables and populate the values for these tables.

Note: If you later make modifications to your filters or structural modifications, you must rerun Metadata Optimizer to reconfigure the dimension tables.

3. Relaunch BSC Builder and navigate to the main tabs window. Select the tab by which you want to filter.

Figure 3–22 Regional VPs Tab With Filtering Button Selected

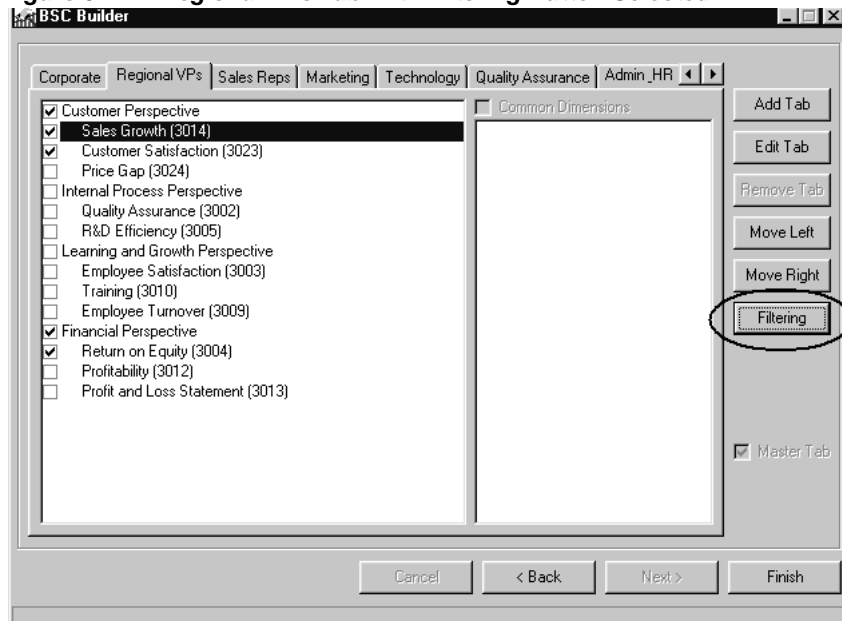

4. Click the Filtering button. A dialog box appears.

Figure 3–23 Filtering Window for Regional VPs Tab

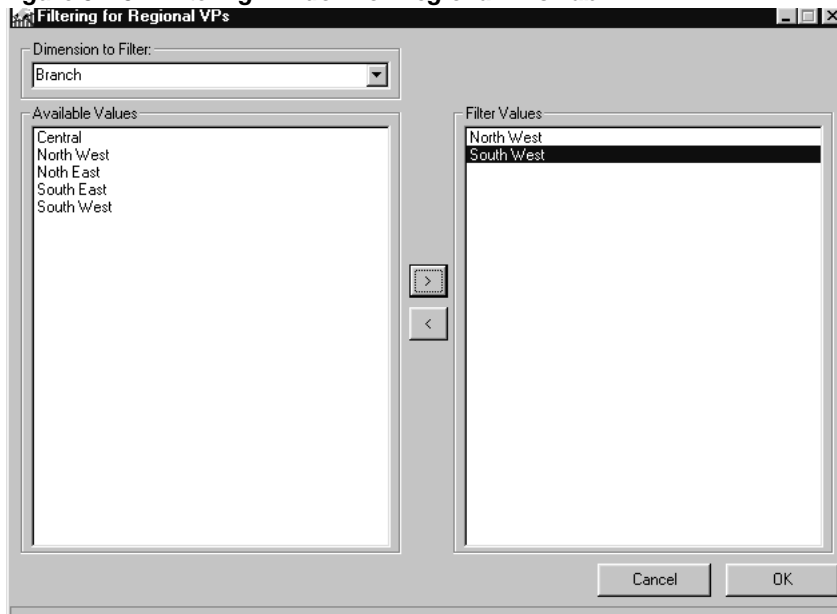

5. Select a dimension from the pull-down list to show the list of Available Values for that dimension.

Note: When filtering a child dimension, its parent must be filtered first. For instance, to filter by district (a child of region), you must filter by region first, then by district.

6. Choose the value, then choose the right-arrow button. The selected value moves to the Filtered Values frame. To remove a value, choose the value, then choose the left-arrow button. To choose all values at once, choose the double-right-arrow button. To remove all values at once, choose the double-left-arrow button. Choose OK.
7. Exit BSC Builder and launch KPI Designer. Select the tab that you want to filter and choose the KPI the filter was applied to. The KPI shows only the data associated with the filtered field. For example, if you selected Country, the KPI would only show dimension values for the country associated with that tab.

KPI Designer Wizard

Once the underlying structure of a balanced scorecard has been created using the BSC Builder wizard, you are ready to begin the next phase of the design process. With KPI Designer, you format the layout of the scorecard's main window and each of the KPI indicator windows. KPI Designer also lets you specify all the details for each KPI including the analysis options, dimensions, and general settings.

The design steps facilitated by KPI Designer are:

- ❑ **Design and Create Additional Views:** The KPI designer will create a default view when you create scorecards, groups, and indicators using BSC Builder. KPI designer allows you to define the characteristics for this view and create additional views, as required, to reflect your strategy.
- ❑ **Formatting the Layout:** Layout determines the indicator group panels and directional lines that will appear on the balanced scorecard's main window and for each tab.
- ❑ **Creating Analysis Options:** Each analysis option represents a unique set of data associated with the key performance indicator. Each indicator can have multiple analysis options but only one options will be the default for the indicator. The status of the default analysis option determines how indicator status is reported on the main window. Again it's important to plan ahead, since determining which analysis option is of primary importance to the KPI is critical to the success of your scorecard.
- ❑ **Creating Analysis Groups:** Analysis options are typically arranged into groups. These groups are interactive, since the user must select an analysis option from each independent group to specify which view of the data is displayed. To effectively design analysis groups, you need to think carefully about the type of information that should be displayed in each indicator window.

- ❑ **Designing Data Dimensions:** Data dimensions are drill downs into specific views of the data. Here you create data dimensions, which you can then assign to each analysis option, if desired.
- ❑ **Defining Global Settings:** Oracle Balanced Scorecard enables you to define global settings for the entire balanced scorecard, as well as custom settings for each indicator and analysis option. At this step, you define settings for periodicity, calculations, benchmarks, fiscal year, cause and effect relationships, and color triggers.
- ❑ **Specifying User Buttons:** User buttons give scorecard users access to additional features and tools. As the person who is designing the balanced scorecard, you activate the user buttons required for your balanced scorecard.
- ❑ **Using Datasets and Sources:** Each analysis option must be assigned to a dataset. Each dataset will be reflected in the input tables for the KPI. Properties must be set for both the datasets and data sources.
- ❑ **Creating What-if Simulations:** What-if simulations allows users to simulate the effects of changes in the performance of key factors on overall results. A what-if simulation can demonstrate how to improve the performance of key factors by simulating the impact of related variables. Creating a What-if Simulation is an advanced procedure and is usually done after the rest of the balanced scorecard design is in place.

These design tasks may be completed in the order listed here, or you can re-arrange steps as you evolve your own design process. It is important, however, to complete all these steps in the course of the design process.

Formatting the Layout of Balanced Scorecard Main Views

Use the KPI Designer to format the layout of the Balanced Scorecard views and indicators belonging to each scorecard. You, as the designer, have multiple alternatives to design and create multiple scorecard views that represent your scorecard and your strategy.

When you first open the KPI Designer the default view is the Scorecard view. This view reflects the configuration that was previously done in BSC Builder, including the scorecards (tabs), groups, and indicators that you created. You can modify the layout of this view to meet your own representation of scorecard and strategy. Besides this default view, additional views can be enabled and created. If you have created multiple scorecards (tabs), each scorecard can be individually formatted with particular characteristics and set of views. For each scorecard you can

configure the following views: Scorecard View, Strategy Map View, and as many "Custom Views" as you need.

Configuring the Scorecard View

The Scorecard View is the default view that appears the first time you open the KPI Designer. You can assign another view as the default view in a later step. The main characteristic of the Scorecard View is that it represents the Groups of Indicators that belong to a Scorecard. The Group name that you created in the BSC Builder is represented in this view. Initially, the different groups will be located randomly in the view.

KPI Designer lets you move groups in two ways. You can enable Drag Drop Mode and manually relocate the group to an approximate location on the scorecard. If you wish to move the group to a precise location, use the editing window to specify the coordinates.

►►To move a group panel:

1. Right-click inside main window area of the scorecard or strategy map main view.
2. From the pop-up menu, select Enable Drag Drop Mode.
3. Click inside the area of a group panel.
4. Hold down the left mouse button and drag the group panel to the desired location.
5. Repeat steps 3 and 4 for each group.
6. Fine tune the placement of the panels by using the group editing window to specify a panel's precise coordinates on the window.
7. When you are finished making changes, click the Save button to save, or Cancel to cancel.

►►To specify a panel's precise location:

1. Right-click in the area of the group panel. Be careful not to click near a KPI since this will display the KPI's indicator window instead.
2. From the pop-up menu that appears, select Edit Group Position to display an editing window.

3. Use the scroll bars beside the Top and Left options to incrementally adjust the placement of the panel on the window.
4. Use the scroll bars beside the Height and Width options to incrementally adjust the size of the group panel.
5. When you are finished making changes, click the Save button to save, or Cancel to cancel.

Formatting Directional Lines

Directional lines can be used to show the relationships between groups of indicators.

►► To create and edit lines:

1. Right-click in the area outside of the group panels.
2. When the pop-up menu appears, select Add a Line.
3. From the sub-menu, select Vertical Line or Horizontal Line. A new line appears on the screen.
4. Right-click directly on the line to display a pop-up menu.
5. Select Edit Line Properties to display an editing box.
6. Use the scroll bars beside the Top and Left options to incrementally adjust the position of the line on the window.
7. Use the scroll bars beside the Height and Width options to incrementally adjust the size of the line.
8. Add an arrow to the line by selecting the Arrow Up or Down radio button. Remove an existing arrow by clicking None. (None is the default.)
9. When you are finished making changes, click Save to save or Cancel to cancel.

Configuring Additional Views

As a designer, you have the ability to define and design multiple scorecard views that represent your strategy according to your preferences. Typically there are three ways in which a view can be defined in KPI Designer. Notice that all views for an scorecard (tab) have the same indicators, but the representation changes:

- Scorecard View:** The Scorecard View is the basic representation of your scorecard. It displays the groups in which your indicators are organized and the

groups can be displayed in any order to represent the relationships between groups.

- ❑ **Strategy Map View:** The main purpose of this view is to be able to represent the cause and effect relationships between indicators. The indicators are usually organized by perspective.
- ❑ **Custom Views:** This view is intended to give total flexibility in the graphical design of the scorecard view. The designer can use any other application to create a "gif or jpeg" image that represents the company or division strategy. You can create as many "custom views" as you want per Scorecard.

To configure any of the additional Views or switch between the different views available, use the Icon available in KPI Designer at the bottom menu bar in the KPI Designer. This button only appears in Design Mode (not in BSC Viewer).

Figure 4–1 Edit Views Icon.



Initially, the The top part lets you select the views configured in design, or the bottom part lets you create additional views.

To enable additional views go to the "Edit Views" option. Initially the default option presented in this menu is the Strategy Map View.

You can enable the Strategy Map View or create additional "Custom Views" by clicking the " ADD" button.

The creation and options available of each particular view is described in detail in the following section.

Configuring the Strategy Map View

To configure the Strategy Map View, first activate the "Edit Views" option as explained in the previous section using the following icon available at the KPI Designer.

When you enable this option, a menu to edit the views will appear containing the Scorecard View (which is the initial default) and the Strategy Map View.

If you want to enable the Strategy Map View as one of your Scorecard Views, position your mouse on the "Strategy Map View" option:

You have 2 options available in this menu: "Enabled" and "Set as Default".

- To enable the Strategy Map View select the "Enabled" checkbox.
- If you want the Strategy Map View to be your default View in BSC Viewer, select the Default checkbox. Notice that you could choose any view to be your primary default view, but only one view can be your default.

Once you enable the View and click OK. The icon to select and Edit Views will contain your new view Strategy Map View option.

This functionality is available for the end user in BSC Viewer only if you enable the "Projection" user button in your indicator. Remember this must be enabled or disabled per Indicator, it is not a global property.

Note: The top part of this menu lets you switch between the views available. In this case, between Scorecard View and Strategy Map View. The bottom part of this menu "Edit Views" option lets you create additional "Custom Views".

Initially the Strategy Map view will consist of an empty screen. To this view you may add KPIs, but only those that have been assigned to the tab in BSC Builder. You may also position KPIs, establish horizontal and vertical divisor lines, add labels, add lines and arrows, and modify the zoom and font to make an attractive fit on the screen. Each KPI is represented by a square box, or node.

Enable Drag & Drop Mode

To be able to move items on the screen by clicking and dragging them you must first enable drag and drop mode. To enable drag and drop mode, right-click on an empty part of the screen and from the pop-up menu that comes up select Enable Drag & Drop Mode. A check to the left of the menu item will confirm your selection

Adding Indicators

To add an indicator right click on an empty area of the screen and select Add Indicator from the pop-up menu. You will notice that you are only given a selection of the KPIs that have been assigned to this tab in BSC Builder. If you do not see a KPI you will have to go back and add it using BSC Builder.

Adding Lines

All lines in the Strategy Map view are arrows. To add a line select Add Line from the pop-up menu and then choose either vertical or horizontal.

Adding Division Lines

Division lines are long, clear, beveled lines run either horizontally or vertically on the screen, either from top to bottom of the view if a vertical line, or from side to side of a horizontal line. They cannot be shortened and they are generally used as "swimming lanes" to delineate perspectives or strategic objectives that KPIs may belong to. To add a division line right click on an empty area of the screen and select Add Division Line from the pop-up menu and then choose either vertical or horizontal. To move a division line click on it with your mouse and drag it to its new location.

Adding Labels

Labels can be added and placed anywhere on the screen. To add a label, select Label from the pop-up menu. To edit the label, click on it and type.

Zooming In and Out and Increasing and Decreasing the Font Size

Using the Zoom In and Out and Increase and Decrease Font Size features you can achieve an elegant fit of your KPI's on the Strategy Map view. Zoom in and use a larger font when you only have a few KPIs, and zoom out and use a smaller font when you have a large number of KPIs you must show on the screen.

Saving Your Changes

Use the Save button to save the changes you have made.

Note: Ensure that you see all the indicator boxes in the KPI Designer when you use the Zoom In or Zoom out property. If you use this property and leave boxes out of the KPI Designer area, you will not see all the indicator boxes in the Viewer.

Figure 4-2 Strategy Map View

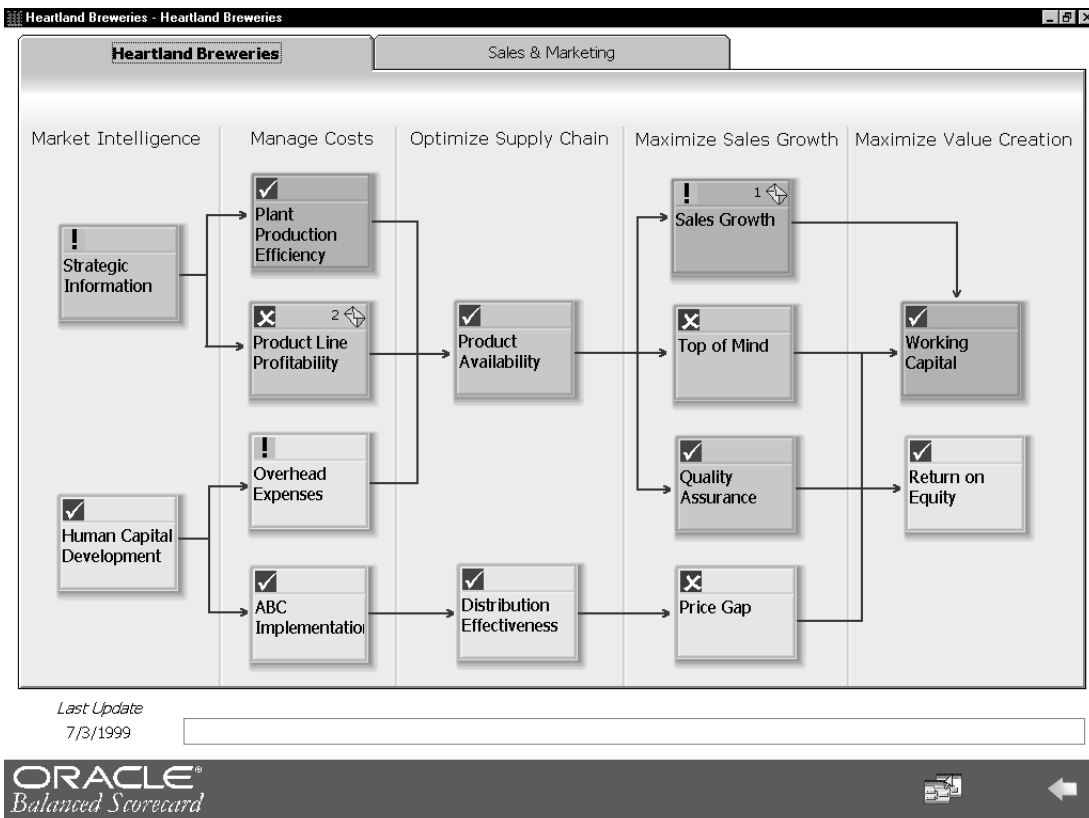

Setting KPI Properties in the Strategy Map View

Several properties are available for each KPI in the Strategy Map view. They are available by right clicking on an individual KPI. Right-clicking on a KPI brings up the following menu:

Figure 4–3 KPI Pop-Up Menu

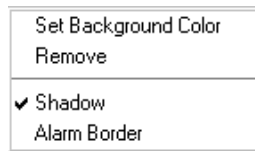

Setting the Background Color

The background color of the KPIs may be set by selecting the first menu item. Background colors are useful to identify different strategic objectives, or other themes running through KPIs in the Strategy Map view.

Removing a KPI

To remove a KPI from the Strategy Map view select Remove from the pop-up menu

Enabling the Shadow

To enable the shadow, select Shadow from the pop-up menu. When a checkmark is next to the menu item it means the shadow is enabled. To remove the shadow select the menu item again to remove the checkmark.

Enabling the Alarm Border

In addition to the colored square at the top left of the KPI, the status of the indicator (red, yellow, or green) can be identified by a border which also changes colors to indicate status. To enable this alarm border select Alarm Border from the pop-up menu and ensure the checkmark is next to the menu item. To remove the alarm border select Alarm Border again to remove the checkmark.

Configuring Custom Views

The purpose of the Custom View creation is to give the user total flexibility in the graphic design that represents the scorecard. While Scorecard View and Strategy Map view leads the designer user to a pre-defined layout structure of the view, the custom view leaves the graphic design entirely to the user preferences. In this case, the designer can produce an image in any external program, import it to the KPI designer, and then accommodate the key performance indicators in any place in the graph. This process is described in this section.

To configure a Custom View, first activate the "Edit Views" option as explained in the previous section using the following icon available at the KPI Designer.

Initially when you enable this option, a menu to edit the views will appear containing the Scorecard View (which is the initial default) and the Strategy Map View.

If you want to enable a Custom View as one of your Scorecard Views, click the Add button.

The initial name of the view added is "Custom View 1". You can rename this view with any name that better fits your view description. To rename the view, overwrite the name appearing in the Properties box and write your own description.

In addition, you have 2 options available in this menu: "Enabled" and "Set as Default". To enable the Custom View, select the "Enabled" checkbox.

If you want the Custom View to be your default View in BSC Viewer, select the Default checkbox. Notice that you could choose any view to be your primary default view, but only one view can be your default.

Once you enable the View and click OK. The icon to select and Edit Views will contain your new view Custom View option:

Note: The top part of this menu lets you switch between the views available. In this case, between Scorecard View, Strategy Map View and a Custom View. The bottom part of this menu "Edit Views" option lets you create additional "Custom Views".

Remember you can create as many "Custom Views" as you want, following the same procedure just described.

Configuring the Custom View

Initially, the Custom view will consist of an empty screen. Your right mouse click will enable the menu options available:

Loading your base image

The first action you will need to perform to get your Custom View is to Load your base image. You can use any other graphical application such as Paint Shop pro, Visio, or any other you prefer to design externally your base image. The image you import to the KPI designer Custom View must be saved as a "gif" or "jpeg" file. Only these 2 formats are supported.

Once you have ready your "gif" or "jpeg" base image created in any application of your preference, click in the "Load Image" menu to proceed with the import process:

When you click on the "Load Image" menu, a typical browse window will appear to select the "gif" or jpeg" file to import:

Once you select your image, the picture will appear in the KPI Designer Custom View. If the image is bigger that the normal size area, KPI designer will display scroll bars to see the complete picture.

For the purpose of this explanation, see the following "gif" file as an example:

Once the file has been imported into the KPI Designer you can start adding indicators to your picture according to your preferences.

Adding Indicators

To add an indicator, right click on an empty area of the screen and select "AddIndicator" from the pop-up menu. You will notice that you are only given a selection of the indicators that have been assigned to this tab/scorecard in BSC Builder. If you do not see an indicator you want in this view, you will have to go back and add it using BSC Builder.

When you add an Indicator, two elements are added to the view:

- Indicator Name Link
- Alarm color associated to the indicator

You can drag and drop the indicator or the color alarm box to the place that fits better in your image according to your design.

Drag and Drop Indicators

To be able to move the indicator name or color alarm box on the screen by clicking and dragging them you must first enable drag and drop mode. To enable drag and drop mode, right-click on an empty part of the screen and from the pop-up menu that comes up select Enable Drag & Drop Mode. A check to the left of the menu item will confirm your selection.

After you finish adding and placing all indicators and their corresponding alarm boxes, you can disable the "Drag and Drop" mode and you will have active links to the indicators in the view.

Note: It is important to notice that during the "drag and drop" process, both elements: the indicator and alarm box are moved separately, then it is responsibility of the designer to place the color besides to the corresponding indicator. Both the designer and end user will see a ToolTip in the alarm box with the indicator name to make easier the process of association.

Additional Options for Indicators in Custom View

As shown in the following figure, there are some options available in KPI Designer to refine your Custom View design. These options apply basically to the text of the indicator that has been added to the view.

Show or Hide Text In some cases, it is possible that you may want to import your image with the Indicator text description already. In this case you may need to add your active link or hot spot to your existing text without adding the Indicator Name again. To do this, you can right click on your indicator text and use the property "Show Text". By default the text is added when you add the indicator, but you can hide the text and just leave the color alarm box using this property. If you decide to hide the text, the property "Show Text" will not display the checkmark in the menu.

Set Font and Properties When you add indicators to your imported image it is possible that the Indicator Text does not fit in your box or graphic design, as you need. It may be too small or too big. KPI Designer gives you some options to decide the font size that better fits in your design. There are four sizes of font available from Small (6 points), Medium (8.4 points), Large (12 points) and Extra-large (16 points). You may want to try each one of them until you find the best size for your image.

It is also possible to change some other properties in the indicator text font such as style: Italic or Bold, or the color of the font to match with your design colors backgrounds.

Remove Indicator This option allows you to remove the indicator name text and the associated color alarm box from your Custom View. Notice that the indicator is not removed from the tab/scorecard, it is only removed from your view.

Note for all Views: It is important for the designer or consultant working with these views, to review continuously how the designs of Scorecard, Strategy Map or Custom Views look in the final HTML Viewer. Some minor resizing issues may occur depending on resolutions used by the final end users, or when fonts too small are used. Particularly in the Strategy Map View, be careful using the Zoom in and Zoom out options to be sure the design and indicator names are readable in the final Viewer.

Configuring Key Performance Indicators

The first part of this section describes the procedure for configuring master and shared KPIs. The rest of the section describes how to configure a KPI completely, including how to create analysis groups and options; how to use datasets; how to design data dimensions; and how to define global KPI settings.

Configuring Master and Shared KPIs

While many KPIs belong logically in one tab, you may wish to share KPIs between tabs. For instance, you may want a KPI to be visible to different organizational units with small variations in its view but with the same overall meaning and purpose.

Rather than copy and recreate the indicator in different tabs, you can share a master indicator that can be customized in different views, hiding or exposing options that are relevant for a particular tab. Once this functionality has been enabled in BSC Builder (see Chapter 3, "BSC Builder", section titled "Configuring Master and Shared KPIs"), you can use KPI Designer to do final configuration of your KPIs.

For instance, suppose the Sales Growth KPI is configured as a master KPI in the Regional VP tab but is shared with the Marketing and Corporate tabs. The Corporate tab might show a high-level view of the KPI showing Sales Growth by Country, Region and Product but hide other options such as market share, number

of units and so forth. By contrast, the Marketing tab, while retaining the same indicator structure, might show more options related to product and customer type. All these options are configured in KPI Designer through the User Wizard.

Note: If the user creates a shared KPI using a master that was in production mode (i.e., already contains data), the user needs to rerun Metadata Optimizer and BSC Loader on the input table that feeds the master KPI. This is done to make sure the shared KPIs show the updated information and color.

►►To configure the master KPI:

1. Follow the steps to create a master KPI in Chapter 3, "BSC Builder", section titled "Master and Shared KPIs" on page 3-15.
2. Define the complete set of dimensions, analysis options, periodicity, calculations, benchmark, data series and all the properties for data and dimensions. All these steps are described in subsections of the "Configuring Key Performance Indicators" section which begins on page 4-13. Remember that the design of the master KPI has to be completed before shared/dependent KPI are intended to configure since any modification in the master affects and resets shared KPIs.
3. Once the master is defined, enable the User Wizard from the Master Tab. You will use this wizard to define all possible hide or show analysis options, series, dimensions, calculations and benchmarks for that the Shared KPI. For more information, see "User Wizard" on page 4-86.

►► To configure shared KPIs:

1. Go to a second tab and click on the shared KPI. When you try to launch the same KPI in a tab different than the Master you will notice (as in Figure 4–4) the KPI designer main menu is disabled except for cause and effect. The User Wizard option has to be previously enabled from the Master KPI and appears enabled as an icon.

Figure 4–4 Sales Growth KPI, Configuration Options Disabled



2. Launch the User Wizard using the icon in order to define which of the options are going to be hidden or showed in the particular shared KPI (see "User Wizard"). Remember that this process is done by tab, so you can choose different set of options to show or hide depending on the tab. When you are finished, the shared KPI incorporates all the changes you have made; any fields or dimensions you unchecked will be hidden. For instance, in the Sales Growth KPI, you chose to expose Country, Region and Product dimensions but hide the other dimensions. With this Dimension Level Lists configuration, the KPI appears as shown in Figure 4–5, "Sales Growth KPI - Configuration 2".

Figure 4–5 Sales Growth KPI - Configuration 2



Suppose you opted for a different Dimension Level Lists configuration. For instance, you might choose to hide the Country, City and Branch dimensions but expose the rest of the dimension set. With this configuration enabled, your Sales Growth KPI appears as shown in Figure 4–6, "Sales Growth KPI - Configuration 3".

Figure 4-6 Sales Growth KPI - Configuration 3

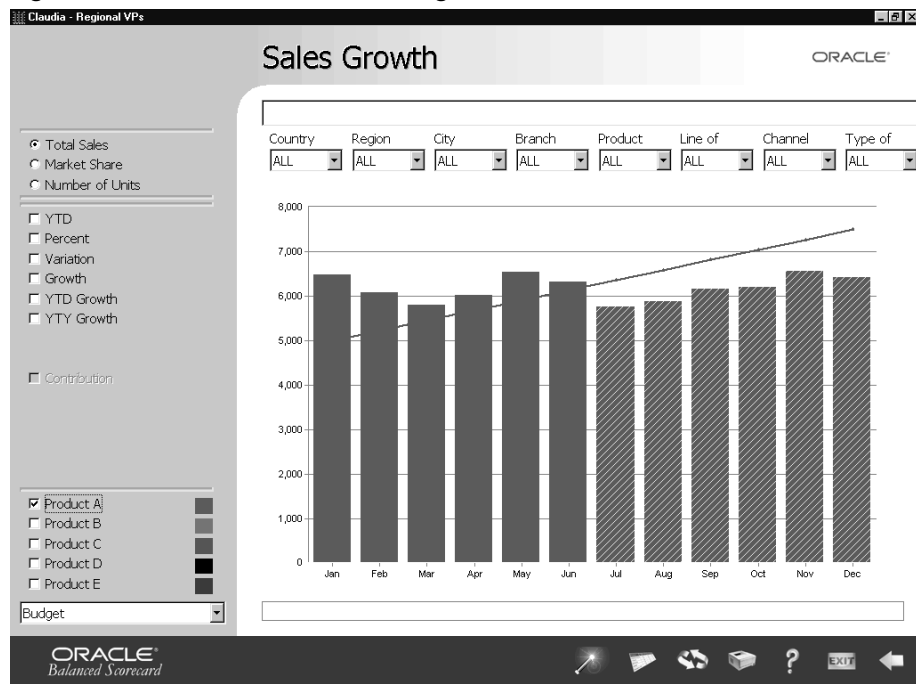

Note: If the user creates a shared KPI using a master that was in production mode (i.e., already contains data), the user needs to rerun Metadata Optimizer and BSC Loader on the input table that feeds the master KPI. This is done to make sure the shared KPIs show the updated information and color.

Note: Be aware that every time you modify a master KPI every shared KPI will be affected with the change. This is especially important when you configure your master and shared KPIs in KPI Designer. For instance if you add or delete dimensions, add analysis options, add datasets, etc, all the shared KPIs depending on this master are going to be refreshed. This means previous changes done to shared KPIs are reset based on the master modifications.

Creating Analysis Groups and Options

Analysis options allow the user to analyze the data from various viewpoints using different measurements associated with the KPI. Analysis groups allow you to organize related analysis options together.

The first analysis group is important since this serves as the parent group for any other analysis groups you create. The parent analysis group should reflect the core measurements or variables you wish to associate with the indicator. The default analysis option in the parent group is extremely important. This is the core measurement you wish to associate with the indicator. Results for this one variable determine the indicator's alarm color on the main panel. You can set any analysis option in the group as the default option.

Subsequent analysis groups include secondary measures which focus on more detailed data. Subsequent groups can be dependent or independent in relation to analysis options in the parent analysis group.

Dependent groups include variables that are associated with a specific analysis option in the parent group. The parent analysis option must be selected for the dependent group to be displayed. In the example below, when the parent analysis option, "Loans Portfolio" is selected, a dependent group related to loans is displayed.

Example 4–1 *Dependent and Independent Analysis Groups and Options*

Case 1. Dependent Analysis Group with 6 analysis options dependent on Loans Portfolio:

Figure 4–7 *Dependent Analysis Group With Analysis Options*

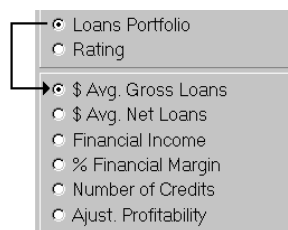

Case 2: Analysis Option "Rating" does not contain any dependent group:

Figure 4–8 *Independent Analysis Option*

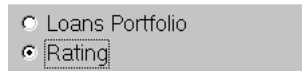

Case 3: Dependent Analysis Group with 2 dependent analysis groups:

Figure 4–9 *Dependent Analysis Group With Dependent Groups*

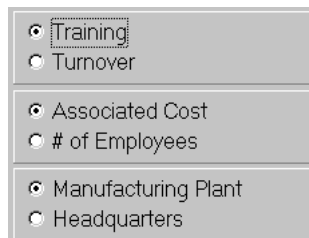

Independent groups are not related to any specific option, they are relevant to all variables in the parent analysis group. An option from the independent group must always be selected when viewing data. In the example below, the parent analysis option "Rating" doesn't contain any dependent groups.

Creating Analysis Groups

When you first open an indicator window in KPI Designer, a blank template is displayed which includes a sample analysis group and option.

►► To create an analysis group:

1. Click an indicator on the KPI Designer main window. A template window for the selected indicator appears.
2. Right-click in the area at the right of the window.
3. From the pop-up menu, select Add Analysis Group.

4. A dialog box appears asking if you want the new group to be dependent. If you want the new group to be dependent on another group, click the radio button of the parent group to select it, then click Yes in the dialog box. Click No if the group should be independent. A new analysis group with a sample option appears in the right panel.

Analysis Options

Once an analysis group is created, you are ready to populate it with analysis options. Each analysis option represents a unique set of data that can be displayed in the indicator window. You must designate one of the options as the default selection. *Default options are important since they determine the alarm color for the indicator.*

►► To create an analysis option:

1. Right-click inside the area of the group panel to which you wish to add the analysis option.
2. From the pop-up menu, select Add Analysis Option. The KPI Designer Analysis Options Property window appears.
3. In the Caption field, enter a title for the analysis option. This title will appear beside the radio button in the indicator window.
4. In the Description field, enter a brief description of the analysis option.
5. Check the Default Box if you want this to be the default analysis option.
6. Click OK to save your changes or Cancel to cancel.

Using Dynamic Dimensions

You can specify which dimensions appear when you select an analysis group in the KPI Designer window.

►► To modify which dimensions appear:

1. Right-click in the area inside the group at the top left corner of the screen.
2. From the pop-up menu, select Analysis Group Properties. A properties window appears.
3. Click in the checkbox beside Modifies Dimension Set to create a checkmark.
4. Click OK to save, or Cancel to cancel.

Using Datasets and Data Sources

Each combination of analysis options must be assigned a dataset. A dataset identifies the specific set and type of data that displays in a KPI's indicator window when the analysis option combination is selected.

In prototype mode, the dataset specification also controls how random data appears in the KPI indicator window. Later on, when the system administrator inputs actual data, the dataset is used to identify the type of data the user should be prompted for in the input tables and whether a formula is required or not.

Formula-based datasets consist of two data sources and an operation which defines the relationship between them. Formulas for datasets must be based on an addition, subtraction, multiplication or division operation.

Note: If you want to associate a dataset with a formula of more than two operands, you must follow a special procedure (you cannot use the Formula tab). For more information, see "Formula Datasets With More Than Two Operands" on page 4-27.

Assigning a Dataset to an Analysis Option

The following procedure associates an analysis option with a particular dataset.

►►To assign a dataset to an analysis option:

1. Select the analysis option you wish to assign to a dataset.
2. Right-click in the area beneath the analysis group panels to display the pop-up menu.
3. Select Assign Datasets. The Assign Datasets window appears.

Figure 4–10 Assign Dataset Window

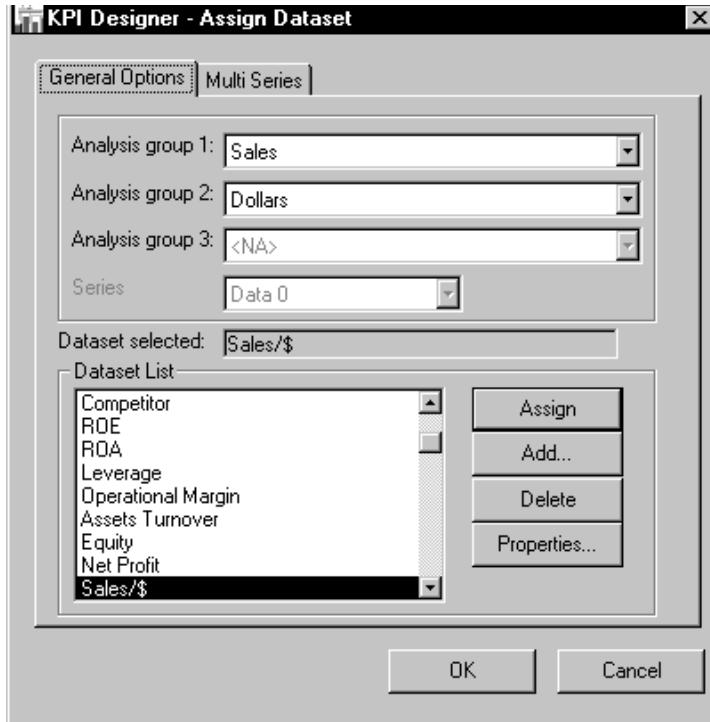

4. The Current Selection panel displays the current analysis options. Verify that the selection is the one you wish to change. Change the selection using the drop-down arrows.
5. If the dataset you wish to assign does not appear in the Dataset list, click the Add button. The Add Dataset window appears.
6. Enter a name for the new data set and a brief description. Note that data set names cannot be the same as certain keywords (for example, SQL commands or functions).
7. Click OK to save your changes or Cancel to cancel. Once the dataset appears in the list, you are ready to assign it to the analysis option.

8. Click Assign. The selected dataset is assigned to the analysis option. The Dataset selected field confirms your selection.

Note: OBSC releases 4.2 and 4.3 only support up to 1,000 datasets per system.

Setting Properties for a Dataset

Dataset Properties are used to define data ranges for the dataset, which calculations are available, the indicator color method, the numerical format, and how random data will be displayed in the prototype. Each of these can be set using the Edit Data Properties window.

►► To define dataset properties:

1. In the Assign Dataset window, select the dataset you wish to edit from the Dataset list.
2. Click the Properties button to display the Edit Data Properties window.

Figure 4–11 Edit Data Properties Window

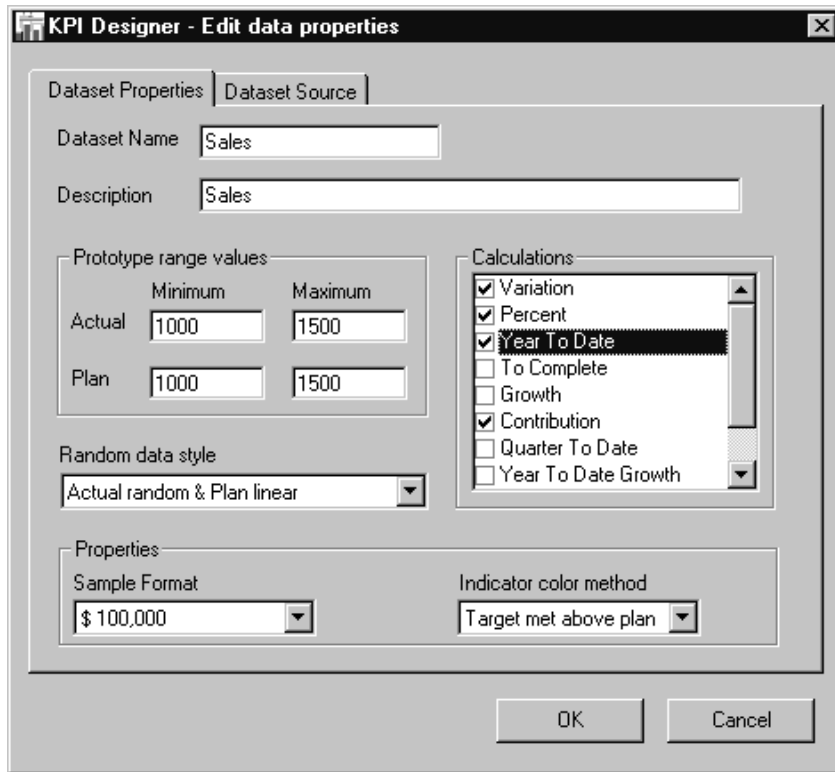

3. Verify that the selected Dataset name and Description are correct.
4. KPI Designer supplies random data to an indicator window while you are in prototype mode. Use the Prototype range values panel to select the range values for the prototype scorecard. In the Prototype range values panel, create a data range for simulations of “Actual” data by setting a minimum value for the First period and maximum value for the Last period.
5. Next set the minimum and maximum values for the First period and Last period for the simulated “Plan” data.
6. Use the Random data styles panel to select the presentation style of random data in the prototype.

- **Actual-Random Plan-Linear:** Displays simulations of actual data as random. Simulations of plan data are displayed as a straight line between the start and end of the specified range values.
 - **Linear-Actual Plan-Linear:** Displays simulations of both the actual data and plan data as linear.
 - **Actual-Random Plan-Random:** Displays random simulations for both the actual data and plan data.
7. In the Calculations panel, select the calculations that you want to make available with this dataset. To activate them, they must be selected on the Calculations window for the KPI.
 8. Use the Sample Format drop-down menu in the Properties panel to select a format for displaying numerical values.
 9. Select a color method using the Indicator color method drop-down menu:
 - **1-Target Met Above Plan:** Color shows when actual results are above the plan for targeted values. Example: revenues or sales.
 - **2-Target Met Below Plan:** Color shows when actual results are below planned values. Example: Production costs, employee turnover.
 - **3-Target Met Within Ranges:** Color shows when actual results are between specified range values (for example, Inventory).

Assigning a Data Source to a Dataset

Every data source is associated with a dataset. The dataset serves as a conceptual framework for the data while the data source contains the actual data content stored in the database. When a dataset is created a data source of the same name is automatically generated and assigned by the system.

►►To assign a data source to a dataset:

1. Right click in the gray area below the analysis group panels to display the pop-up menu.
2. Select Assign Datasets.
3. When the Assign Datasets window appears, select a dataset and click the Properties button to display the Edit Dataset Properties window.
4. Click the Dataset Source tab to bring it forward.

5. From the Datasource list select the source you wish to assign to the dataset and click Assign. If the source you wish to assign is not yet in the Source list, click the Add button.
6. In the Add Source window, enter the name of the source you wish to add and click OK. The new source now appears in the Source list.
7. Assign the source to the dataset by selecting the source name and clicking Assign. The Source selected field at the top of the window confirms your selection.

Formula Datasets

There are two types of datasets. Standard datasets have a single source. Formula datasets, on the other hand, are defined by two data sources and an operation which describes the relation between them.

Note: If you wish to create a formula of more than two operands, use the process described in "Formula Datasets With More Than Two Operands" on page 4-27.

►►To create a formula dataset:

1. Using the instructions provided above, create the first dataset, define it's properties and assign it to a data source.
2. Create the second dataset, define it's properties and assign it to a data source.
3. Create a third dataset.
4. Click the Formula checkbox to display the Formula tab. Click the Formula tab to bring it forward.

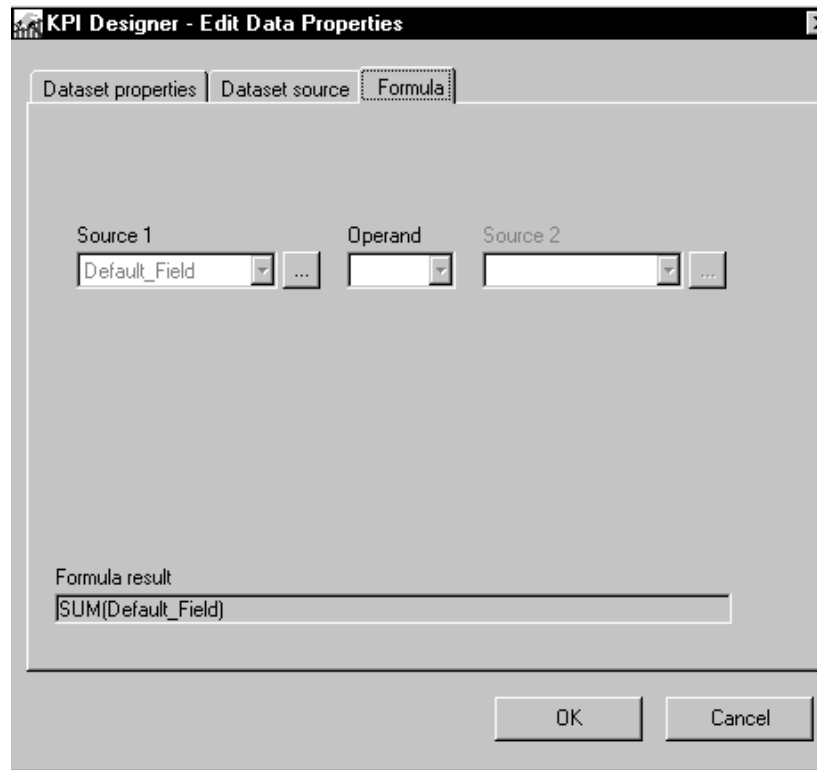
Figure 4–12 *Edit Data Properties Window, Formula Tab*

5. In the Source 1 field, use the pull-down menu to select the first data source for the formula.
6. Use the Operand pull-down menu to select an operation. Options include addition, subtraction, multiplication, and division.
7. In the Source 2 field, use the pull-down menu to select the second data source for the formula. The Formula result field at the bottom of the window displays the resulting formula.
8. Click **OK** to save your changes or **Cancel** to cancel.

Formula Datasets With More Than Two Operands Normal formula datasets are limited to two operands. However, it is possible to create datasets with more than two operands.

►► To create a formula dataset with more than two operands:

1. Log into KPI Designer and choose the KPI containing the dataset in question.
2. Right-click in the area below the analysis groups in the right frame to launch the main pop-up menu, and choose Assign Dataset.
3. From the dataset list in the lower left panel of the Assign Dataset screen, click once on the appropriate dataset, then click the Properties button. The Edit Data Properties window appears.
4. Click the Data Source tab to bring it forward.
5. Add a new source to the Source List by clicking the Add button.
6. Select your new source in the list by clicking once, then click Properties to open the Edit Source Properties dialog box.

Figure 4–13 *Edit Source Properties Window, Source Properties Tab*

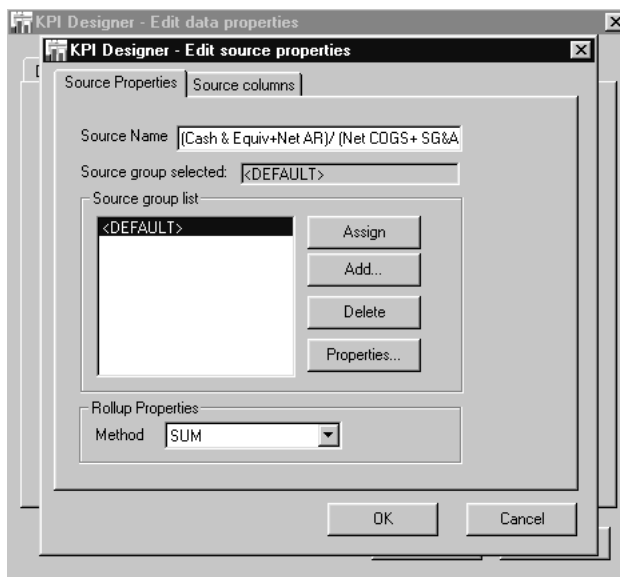

7. In the Source Name field, type in the desired formula you wish to associate with your new source. The formula cannot exceed the 320-character limit.
8. Click OK to return to the Dataset Source window.

9. Now, click the Formula check box and click the Formula tab to bring it forward. Your new source list includes the formula you just defined as a single source. Now you can perform operations on this formula, letting you define complex formulas.

Creating Source Group Lists This optional feature is helpful when you are creating very large scorecards with many indicators and analysis options. Organizing related data sources into Source groups lets you manage the system more easily. If of the same periodicity, the data for all the data sources in a given group are written to the same table in the database, making input and management easier for the system administrator.

There are several different methods that can be used for assigning data sources to groups. With the first method, you create all your data sources and then add these sources to groups. As a second method, you may create sources and groups at random as you work through the scorecard design. Use whichever method suits your personal work style. The instructions provided below are based on the first method and assumes you have already created your data sources.

►► To create source groups and assign data sources:

1. Right-click in the area below the analysis group panels to display the pop-up menu.
2. Select Assign Datasets. The Assign Datasets window appears.
3. Select any dataset from the Dataset list and click Properties. The Edit Data Properties window appears.
4. Click the Data source tab to bring it forward, highlight a data source in the Source list, and click Properties. The Edit Source Properties window appears.
5. Add a group to the Source group list by clicking the Add button.
6. When the Add Group window appears, enter a name for the group in the description field.
7. Click OK to save, or Cancel to cancel.
8. Add all the remaining source groups required by your balanced scorecard.
9. Next assign a data source to the newly created source group. Return to the Dataset source tab in the Edit Data Properties window.

10. Select a data source from the Source list and click Properties. The Edit Source Properties window appears. The name of the selected data source, appears in the Source name field. Confirm that this is correct.
11. Select a group from the Source group list and click Assign. The Source group selected field now shows the name of the source group assigned to the data source.
12. Click OK to save your changes, or Cancel to cancel.

Defining Rollup Properties for a Data Source

Use the define properties feature to assign “rollup properties” for a data source. Rollup properties determine how accumulated data for the data dimension will be summarized in the “ALL” dimension of an indicator window.

►►To assign roll-up properties for a data dimension:

1. Open the Assign Dataset window.
2. Click Properties to open the Edit Data Properties window and then click the Dataset Source tab to bring it forward
3. Select a source from the Source list and click Properties to display the Edit Source Properties window:
4. From Rollup Properties, use the pull-down menu to select a method. Methods available include:
 - SUM: Summation of values
 - AVG: Average of values
 - MAX: Maximum of values
 - MIN: Minimum of values
5. Click the Source Columns tab to bring it forward. Use this tab to define the type of account on which your data is based (Balance or Statistics).

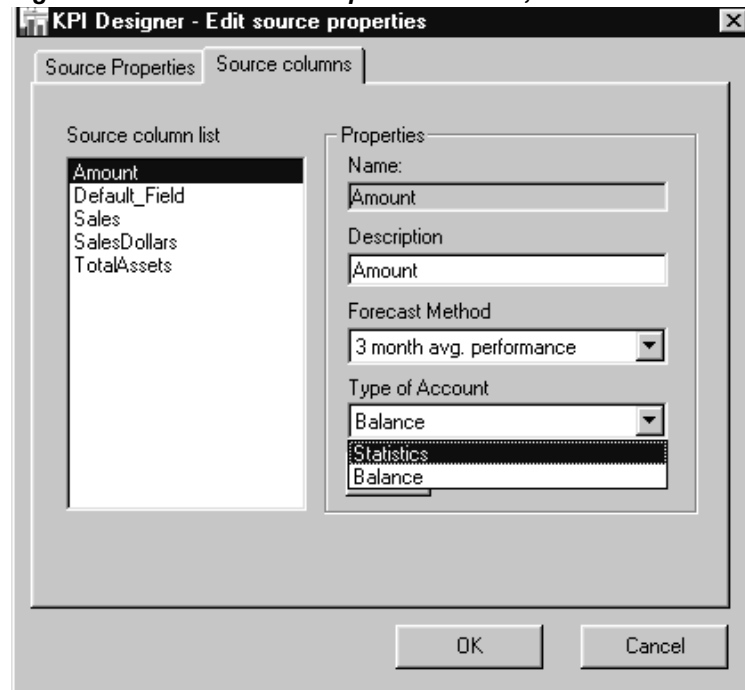
Figure 4–14 Edit Source Properties Window, Source Columns Tab

6. Select an account type from the Type of Account pull-down list.

Statistic: Values are added/accumulated period-by-period or for year-to-date purposes.

Balance: Values are not accrued period-by-period or for year-to-date purposes.

Example 4–2 Rollup Properties for Statistic Accounts

For statistical accounts, if the user clicks on YTD or goes from one periodicity to another, values are added/accumulated period-by-period. Figure 4–15 and Figure 4–16 show the KPI view for Profit Margin, a statistical KPI. When moving from a monthly to a quarterly periodicity, values are added/accumulated, so the quarterly profit margin is net income for all three months of the quarter divided by sales for all three months of the quarter.

Figure 4–15 Profit Margin KPI View, Monthly Rollup

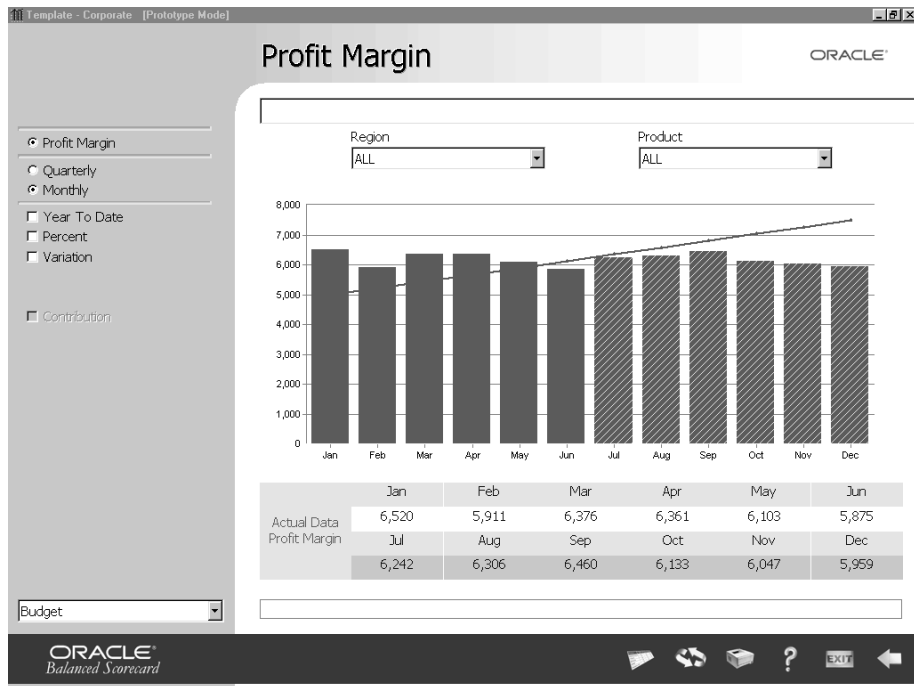
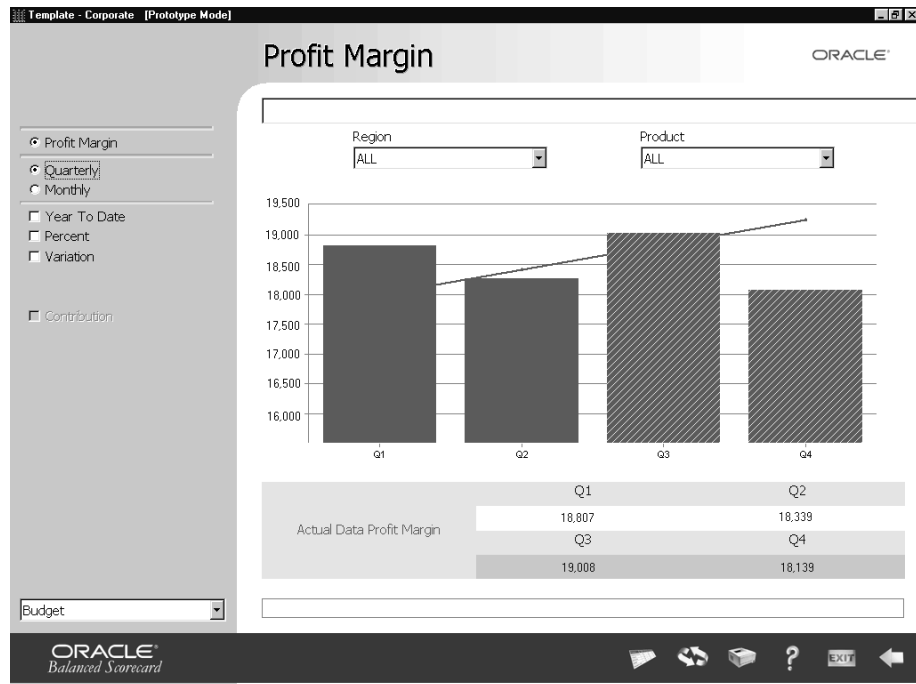

Figure 4–16 Profit Margin KPI View, Quarterly Rollup



Example 4–3 Rollup Properties for Balance Accounts

For Balance Accounts such as Total Assets (see Figure 4–17 and Figure 4–18), if the user changes periodicity (e.g., goes from monthly to quarterly periods), the quarterly KPI view shows the last value of the period. Since Total Assets is a balance account (a snapshot at a point in time), it is not accumulated across periods.

Note: The YTD check box in KPI view is automatically disabled in Balance accounts since it does not apply there.

Figure 4–17 Total Assets KPI View, Monthly Rollup

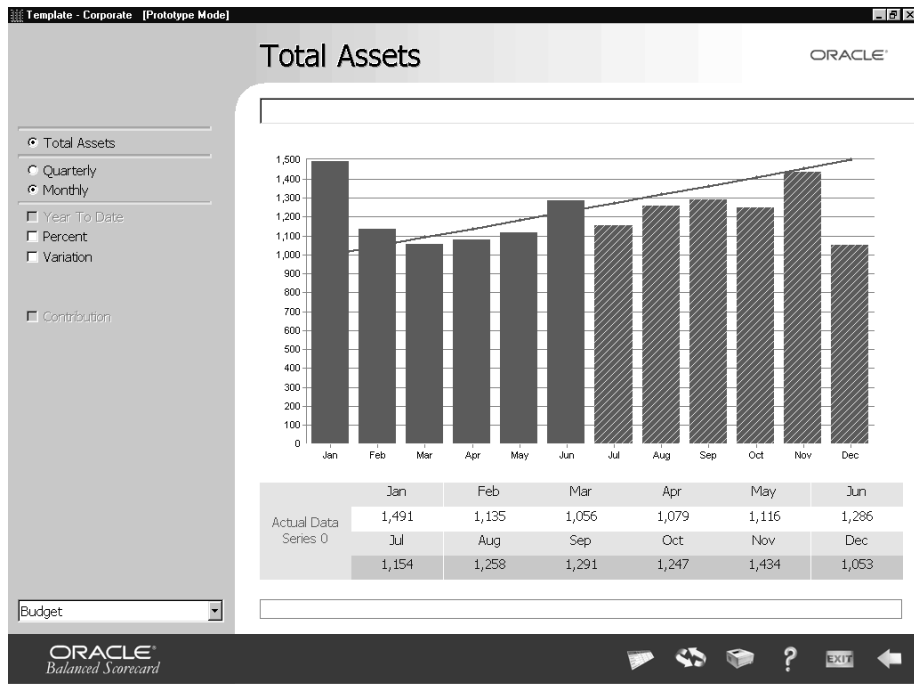
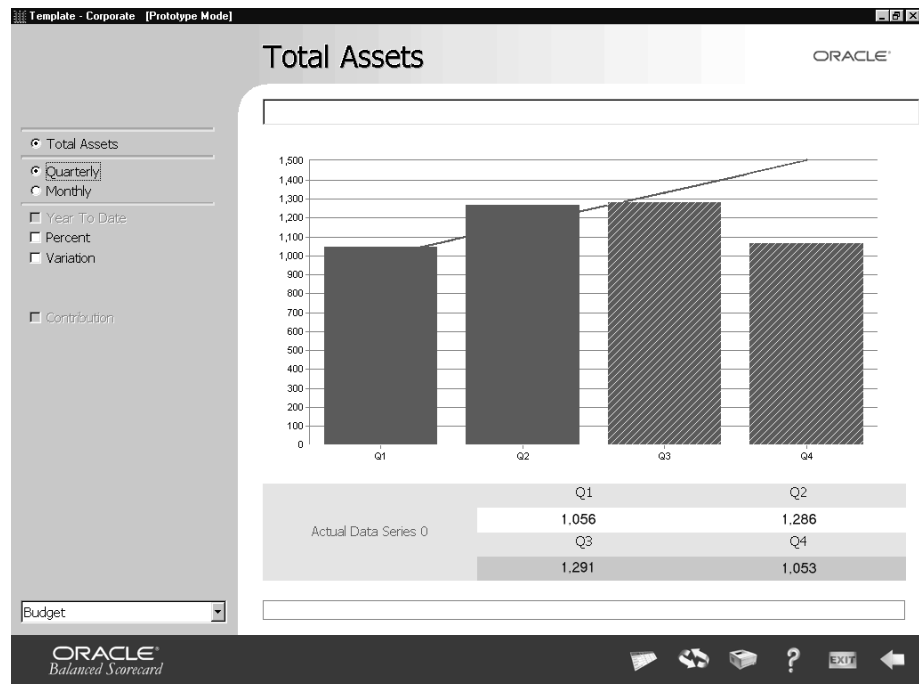

Figure 4–18 Total Assets KPI View, Quarterly Rollup

Configuring Forecasts

Forecasts are calculated by the Oracle Balanced Scorecard to provide users with an estimate of KPI performance for future periods. These forecasts are represented by the shaded vertical bars on an indicator. BSC automatically calculates forecasts beginning with the first period subsequent to the last period of actual data entered, continuing through the last period of the fiscal year.

There are three types of forecasts available to the Oracle Balanced Scorecard. These are selected by the administrator when building the balanced scorecard, and are specific to each analysis option combination, meaning there can be more than one forecast method per KPI. The different methods are:

- **Plan-based:** The plan-based forecasting method calculates the average performance to plan for the last three months and applies that ratio to the plan for each of the succeeding periods to come up with forecasts for those periods.

- **Moving Average:** The moving average forecasting method calculates a moving average for the past year (or less time periods if a year of data does not exist yet). The moving average includes actual and past forecasted data.
- **Custom:** The custom forecasting method allows clients to load in their own forecast data.

Forecast methods are assigned to individual datasets through the data set's data source. Individual data set are then assigned to unique analysis option combination on KPI, therefore projection methods are said to be assigned to analysis option combinations.

►► To select a forecast method:

1. From the KPI Designer pop-up menu select Assign Dataset.
2. Select a Data set by highlighting it. Click on Properties to go to the dataset properties window.
3. Select the Dataset Source tab.
4. Select a dataset source by highlighting it. You may select any of the dataset sources in the system, but you will probably want to select the one which is assigned to your dataset. In the example below "Sales" is the dataset source for the "Sales/\$" dataset.

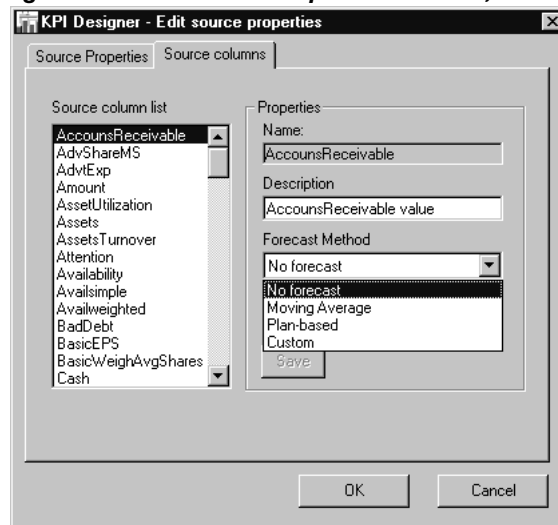
Figure 4–19 Edit Data Properties Window, Dataset Source Tab

5. Click on the Properties button to enter data set source properties.
6. In the Data Source Properties window, click on the Source Columns tab.
7. Select the data source for which you wish to change the forecast method.
8. In the Forecast Method drop down list, select the appropriate forecast method.
9. You may select another data source to modify its forecast method if you wish.
10. When you are finished, click OK to save and return.

Sample Forecast Configurations The following table lists sample actual-to-plan scenarios and the forecasting results under different period plan value scenarios .

Since some calculations cannot be performed using zero or null, the forecast calculation will vary if these instances are encountered.

Table 4–1 Sample Forecast Configurations

Case	Sum of 3 or Less Periods*		Calculation	Formula	If Future Period Plan Value is:		
	Actual	Plan			= 0	= Null	<> 0
A	> 0	> 0	Percent Ratio (PR)	$PR = (\Sigma \text{ Actual}) \div (\Sigma \text{ Plan})$	0	No Projection	PR * Plan
B	< 0 < 0 > 0	< 0 > 0 < 0	Absolute Average (AA)	$AA = \frac{[(\Sigma \text{ Actual}) - (\Sigma \text{ Plan})]}{(\# \text{ of Actual Periods } \leq 3)}$	AA	AA	AA + Plan
C	<> 0	Null or = 0	Average	$Avg = \frac{(\Sigma \text{ Actual})}{(\# \text{ of Actual Periods } \leq 3)}$	Avg.	Avg.	Avg. + Plan
D	Null or = 0	Null or = 0	Plan		0	No Projection	Plan
E	Null or = 0	<> 0	No Projection		No Projection	No Projection	No Projection

- ❑ Plan based forecast data is based on the last three or less periods of actual data: If less than three periods of actual data exist, then the system will use either the last 2 periods, or the last period, depending on what is available.
- ❑ Only the current fiscal year is used, so if only two periods of actual data exist for that year, BSC will not use the last period of last year to figure out the sum.
- ❑ If a period is Null when the Actual or Plan totals are calculated the sum is Null.

This example uses the formula:

$$\text{Percent Ratio (PR)} = (\Sigma \text{ Actual}) \div (\Sigma \text{ Plan})$$

The Σ is for the last three or less months.

Table 4–2 Actual and Plan Numbers for 5-month Period

Month	Actual	Plan
May	10	15
June	20	25

Table 4–2 Actual and Plan Numbers for 5-month Period

Month	Actual	Plan
July	30	25
August	40	50
September	50	NULL

Table 4–3 Example Forecast

Current Period	PR	Future Month	Plan	Forecast
June	$30 / 40 = .75$	July	25	$.75 * 25 = 18.75$
		August	50	$.75 * 50 = 37.5$
		Sep	NULL	No forecast
July	$60 / 65 = .923$	August	50	$.923 * 50 = 46.15$
		September	NULL	No forecast
August	$120 / 100 = 1.2$	September	NULL	No forecast

Example 4–4 Moving Average Example

The following table illustrates how the forecast is calculated using the moving average method when the current month is June. The moving average is calculated by taking the average of the last 12 periods of data, including both actual and forecasted numbers. (If less than a year of actual data exists the system will use whatever is available, up to year maximum). This table shows how the forecast is calculated when the current month is June.

Table 4–4 Moving Average Method

Month	Last Year Actual	Current Year Actual	Forecast	Formula
May	10	12	last	months
June	20	22	current	month
July	30		65.33	average of last 12 months
August	40		68.28	average of (July forecast + last 11 months)

Table 4–4 Moving Average Method

Month	Last Year Actual	Current Year Actual	Forecast	Formula
September	50		70.63	average of (July + August forecasts + last 10 months)
October	60		72.35	average of (July + August + September forecasts + last 9 months)
November	70		73.38	continues in same fashion
December	80		73.67	continues in same fashion
January	90		73.14	continues in same fashion
February	100		71.73	continues in same fashion
March	110		69.38	continues in same fashion
April	120		65.99	continues in same fashion

Custom Loading in custom forecasts are performed in the input files. Data is loaded in the KPIs respective input table with Type = 90 to identify the data as custom forecast data.

Configuring Multiple Series KPIs

Information for some KPIs is best displayed as a multiple series. This allows aspects or subcomponents of the indicator data to be broken out and viewed separately. For example, a KPI related to Customer Deposits may include a multiple series of three subcomponents: Checking, Savings, and CD's.

Each component of a multiple series KPI may be formatted with a separate color using one of several of stacking options to visually delineate the data even further. Multiple Bar KPIs must be defined in the BSC Builder at the time the indicator is created. In KPI Designer, you assign data set properties for the multiple bar KPI and define the formatting options.

General Configuration Rules for Multiple Series KPIs

- ❑ You will be able to create multiple series that can be displayed with the Left Y Axis or Right Y-Axis as the reference axis.
- ❑ There are 2 types of graph types: Stack or Non-Stack. Each series can be represented in: Bars, Lines or Area.
- ❑ For each series you can decide if the series will have a plan or benchmarks for reference.
- ❑ One of the series can be selected as default. This default will drive the color of this indicator in the main panel.
- ❑ The plan and benchmarks are always represented in Lines.

Note: When a user defines two series using the same side of the scale but different format, only the first one is taken into account. The second one and following are not shown.

►►To configure a multiple series KPI:

1. Navigate to the Assign Datasets window by right-clicking in an open area in KPI view and selecting Assign Dataset. Click the Multi-Series tab to bring it forward.

Figure 4–20 Assign Dataset Window, Multi Series Tab

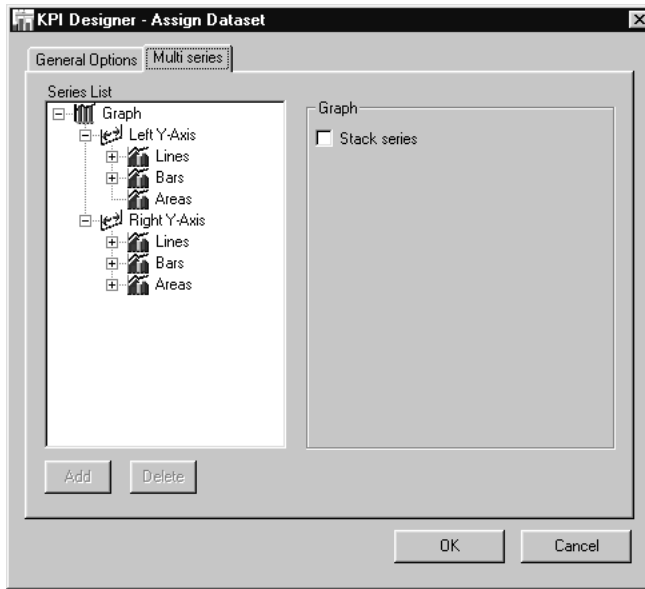

2. At the first level of this window, decide the type of graph: Stack or Non-Stack. If you select Stack, all the series will be stack one on top of another. Use this option for multiple series that you want to represent in a single bar broken in different related portions.
3. To stack series, they must be of the same type (bar, lines, etc). Since the plan and other benchmarks are always represented in lines, it is not recommended to use Stack for Line Series to avoid confusion.
4. Once you have decided the type of graph, start creating the different series you want to represent in the KPI. The series can be created as Lines, Bars or Areas. Click Add to create a series.

Lines: Series data is displayed as line.

Bar: Displays data as bar on the graph.

Area: Displays data as an area of color on the graph.

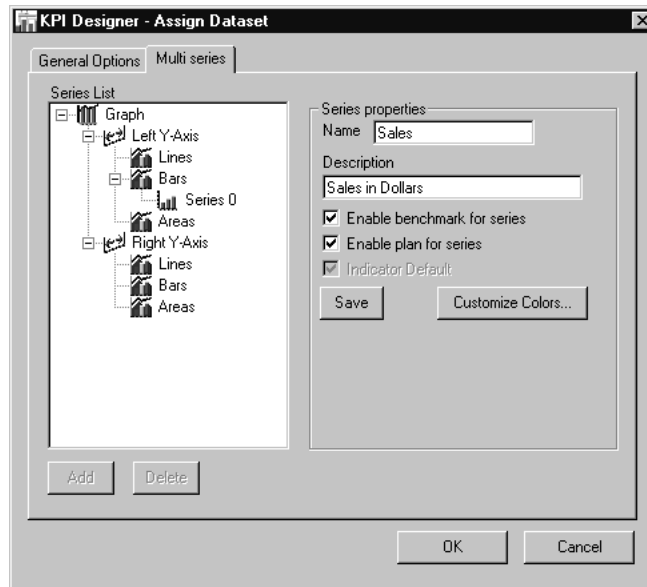
Figure 4–21 Assign Dataset Window, Multi Series Tab, New Series Added

5. You can create series to be displayed in the X or Y axis with different scales.
6. You can also drag and drop series from one group to another. For instance drag and drop Series 1 in Lines to the Bars or Area.
7. Give properties to each Series.

Name: Name of the series

Description: Description for each series

Enable benchmarks for series: When you want to display benchmarks with the series

Enable plan for series: When you want to display plan with the series

Indicator Default: This is the indicator default that will drive the color in the main panel. The first time you enter in the indicator this series is going to be displayed as default.

8. Click the Customize Colors button to select a custom color for each series. You can select colors for all the benchmarks in KPI Designer (see "Benchmarks" on page 4-67). When you are finished choosing colors, click OK.

9. Click on the Save button to save your series.
10. Repeat the above steps to set properties for each remaining series in the series list.
11. Click OK to save your changes or Cancel to cancel.
12. In the Assign Datasets window, assign a dataset to each series.

Designing Data Dimensions

Data dimensions are drill downs into specific views of the data. Dimension sets can include all the dimensions or drill downs assigned to a particular analysis option. Each analysis option combination is associated with a unique dimension set. These dimension sets are displayed in pull-down menus which appear above the indicator graph when the analysis option is selected. A dimension set includes all the dimension groups created for a given indicator.

Data Dimensions are first added and defined in the Dimensions window. Once created, they must be assigned to dimension groups. Finally, dimensions sets are assigned to specific analysis options.

Creating Data Dimensions

Create data dimensions and define their properties using the Define Dimensions tab in the Dimensions window.

►► To create data dimensions:

1. From the main pop-up menu, select Define Dimensions and Dimension Sets. The Dimensions window appears.

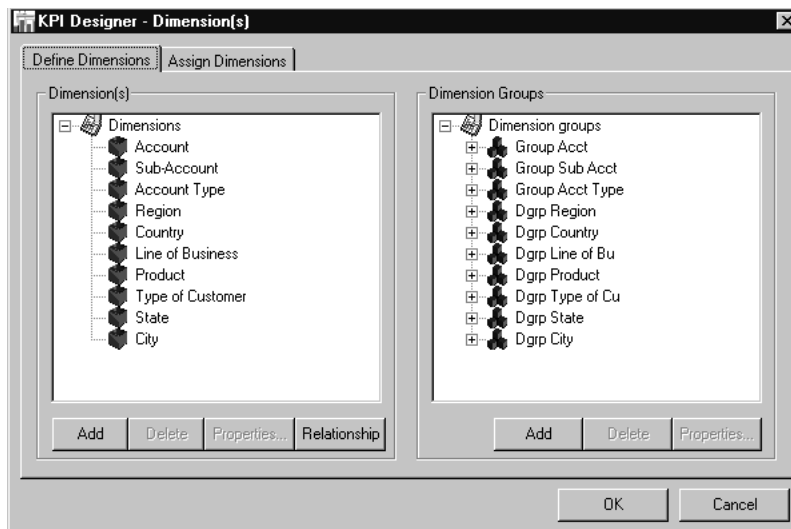
Figure 4–22 Define Dimensions Tab

2. Click the Define Dimensions tab to bring it forward.
3. Click the Add button below the Dimensions panel to display the Add Dimension window.

Figure 4–23 Add Dimension Window

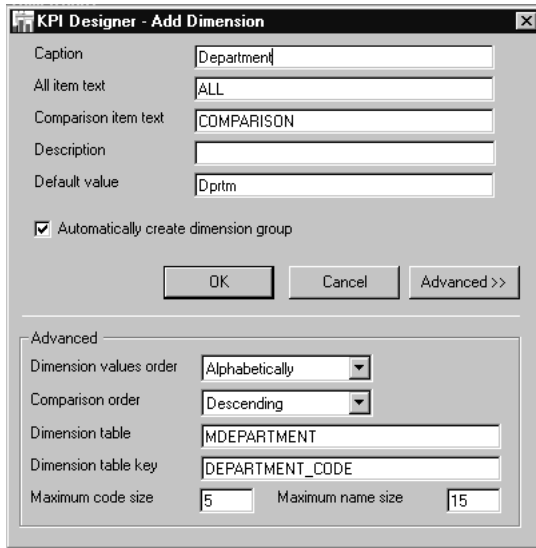

4. Enter a title for the dimension in the Caption field.
5. In the All item text field, enter a title for sum or total.
6. In the Comparison item text field, enter a title for the comparison between dimension values.
7. Default values are prototype dimension values. If you wish you can edit this value. The Default value is an abbreviation of the dimension caption and is only used for the prototype mode.
8. Check the Automatically create dimension group check box if you want a new group to be automatically created for the dimension. You can also create your own groups with selected dimensions by unchecking the automatic option.

Note: You need to create groups because you can only assign groups to KPIs. You cannot assign dimensions to KPIs.

9. Click the Advanced button to display additional options.

10. Use the Dimension values order poplist to select the order in which dimension values are displayed. Valid values are:
 - **Alphabetically:** Sorted alphabetically
 - **System code:** Sorted in the order they were loaded into the table. BSC assigns sequential numbers to records as they are entered or imported.
 - **User code:** Sorted by the user code column.
11. Use the Comparison order poplist to select the order comparison dimensions are displayed. Possible values are:
 - **Descending:** Items are displayed in descending value order.
 - **Ascending:** Items are displayed in ascending value order.
 - **Same as Drill Items:** Same order as defined in the Dimensions Order poplist.

Note: When dimensions are analyzed in Comparison in YTD, the order that will be displayed is always *descending*.

12. It is also possible to edit the Dimension table and Dimension table key fields from this window, but it is not generally recommended since errors generated here can cause database errors or permanent loss of data. The Master Table is the dimension table, where dimension values are held.
13. You can also set the maximum field size (in characters) for the dimension code and dimension name by changing the appropriate values in the Maximum Code Size and Maximum Name Size fields. Note that once you expand the size, you cannot make it smaller.
14. Click OK to save your changes, or Cancel to cancel. The new dimension appears in the Dimension panel. If you selected the Automatically create dimension group checkbox, the new dimension will also appear in the right panel along with a newly created group.
15. Continue adding dimensions, until you've created all the dimensions required by your scorecard.

Creating Dimension Groups

Dimension groups are used to group dimensions. It is important to note that if the user has selected to, a dimension group is created automatically for each dimension that is created. This is done because only dimension groups can be assigned to

indicators, dimensions by themselves cannot. The system therefore attempts to save users from having to define a group for every dimension they define; the dimension group is automatically defined when a dimension is created, and the dimension is placed in the group.

Dimension groups are very useful to group dimensions if often the same dimensions will be assigned to various indicators. This way just one group (containing a number of dimensions) can be assigned to an indicator.

►► To create a dimension group:

1. From the main pop-up menu, choose Define Dimensions and Dimension Sets.
2. Click the Define Dimensions tab to bring it forward.
3. Click the Add button under Dimension Groups.
4. Enter a caption for the new dimension group.

Assigning Dimensions to Dimension Groups

►► To assign dimensions to dimension groups

1. From the main pop-up menu, choose Define Dimensions and Dimension Sets.
2. Click the Define Dimensions tab to bring it forward.
3. Click the Relationships button to open the Relationships dialog box.
4. Select a dimension from the left panel and drag it to the right panel.
5. Continue selecting and dragging dimensions to groups until all the required groups appear in the Dimension Groups panel.

Dimension Relationships

Figure 4–24 *Dimension Relationships Window*

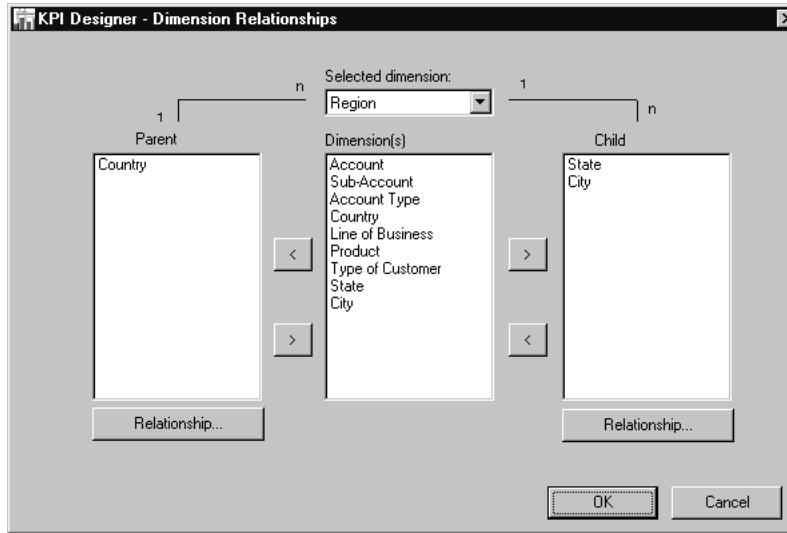

Dimension relationships allow you define parent-child relationships between dimensions. This function is crucial for the proper operation of BSC, including the dimensions and List button features. In addition, input and system table layouts depend very much on having the dimension relationships set up properly.

A parent dimension value has one or more child dimension values that roll up into it. For example, assume the parent dimension is STATE and the child dimension is CITY. Various CITY values (e.g., Sacramento, San Francisco, Los Angeles, and San Diego) roll up into a specific STATE value (e.g., California).

A parent dimension can also roll up into another parent dimension. For example, the STATE dimension can roll up into the REGION dimension (e.g., California, Washington, Oregon, Arizona, and Utah all roll up into the Western region).

You can use parent-child relationships for reporting and other application purposes.

Defining dimension relationships is very simple. Bring up the dimension relationships window by clicking on the Relationship button from the Define Dimensions tab.

▶▶ To define relationships

1. From the main pop-up menu, choose Define Dimensions and Dimension Sets.
2. Click the Define Dimensions tab to bring it forward.
3. Click the Relationships button to open the Relationships dialog box.
4. In the Dimensions (middle) panel, you will see all dimensions defined in the system.
5. Select a dimension to define relationships for in the drop down box at the top of the screen.
6. Using the < and > buttons on either side of the Dimensions panel, move dimensions to the Parent or the Child panels to indicate if the dimension is a parent or a child of the dimension selected at the top of the screen.
7. As you select other dimensions at the top of the screen, the system will automatically display the define relationships.
8. Click OK when you are finished.

Relationship Properties The Relationship Properties window allows you select if the relationship will be a one-to-many (1:n) or a many-to-many (m:n) relationship. All relationships are by default defined as 1:n relationships. To define a relationship as m:n you must use the relationship properties window.

▶▶ To define relationship properties:

1. Click on the Relationship Properties button underneath either the Child or the Parent panel to bring up the window shown below.

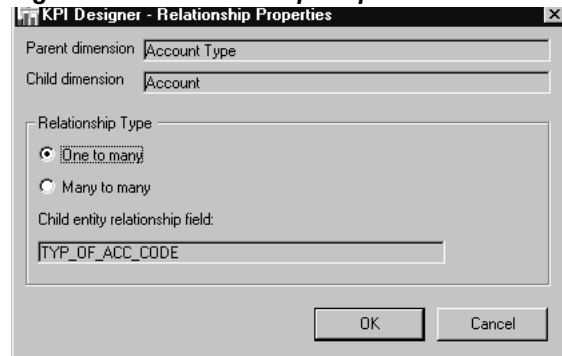
Figure 4–25 Relationship Properties Window

2. At the top of the screen the parent and child dimensions will be displayed.
3. Using the appropriate radio button, select if relationship will be One to Many or Many to Many.
4. No other options are available to change. Click OK when finished to exit.

Dimension Properties in Dimension Group The Dimension properties in the dimension group allow you to specify more advanced settings for the dimension, as it behaves when it is part of a specific group. The settings here help define what should be shown in the dimension, and the settings are dimension group-specific.

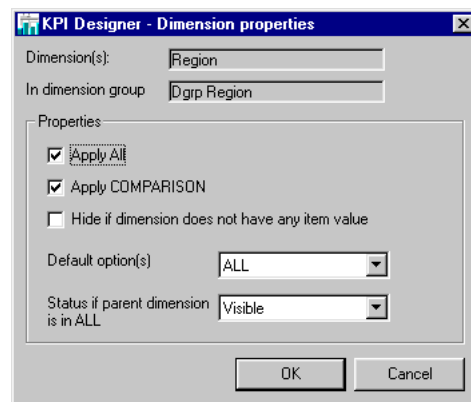
Figure 4–26 Dimension Properties Window

The top part of the screen indicates the dimension and the dimension group that have been selected. These settings will affect this dimension, but only in the dimension group selected; the same dimension can have different settings in another group.

►► **To set the dimension properties:**

1. Check any of the following three checkboxes to set the related property for the dimension and dimension group combination:

Apply ALL: Check this box to display the ALL value in the list of dimension values. ALL is the summary calculation of all of the dimension values.

Apply COMPARISON: Check this box to display the COMPARISON value in the list of dimension values. COMPARISON allows the user to view all the dimension values for the selected dimension compared against one another.

Hide if dimension does not have any item value: Check this box to hide the dimension if there are no related dimension values.

2. Choose a Default option from the poplist. This is the default value for the dimension (when the user first enters into the KPI). The two options are ALL or COMPARISON. This is a Dimension Group-specific setting, so it will take effect whenever the dimension is assigned to a KPI via this Dimension Group.

Note: A Dimension can be assigned to KPI via many Dimension Groups. This setting only applies to the Dimension Group you are modifying.

You can override this setting at the KPI level by selecting a specific value to be the default dimension value that is shown when the user enters the KPI. For example, selecting Maryland as the default dimension value for the States dimension causes the alarm color to be calculated using Maryland actual vs. plan. Maryland is also displayed as the default dimension when a users enters the KPI.

3. Choose a value for the Status if parent drill is in ALL field. This value determines the properties of the dimension if the parent dimension shows ALL. You may choose to hide this child dimension if appropriate. Valid options are Hide, Disable, or Visible.

Assigning Dimension Groups to Dimension Sets

The next step of the design process is to assign the newly created dimension groups in a dimension set.

►► To assign dimension groups and sets to a KPI:

1. Click the Assign Dimensions tab to bring it forward. The left panel shows a list of all the available dimension groups. The right panel shows the current KPI and the dimension sets created for the indicator.

Figure 4–27 Assign Dimensions Tab

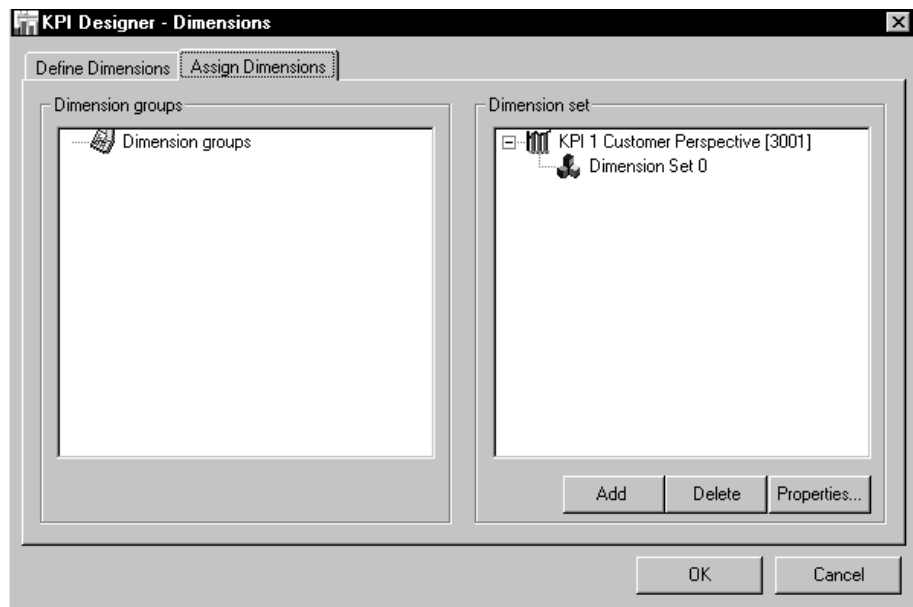

2. To add a dimension group to the KPI, select a group in the Dimension Groups panel and drag it to the Dimension Set panel. The group now appears in the right panel.
3. Continue dragging and dropping groups from the Dimension Groups panel to the Dimension Set panel, until all the required groups have been copied.
4. If you need to add an additional dimension set to the KPI, click the Add button. A new dimension set appears in the list.

5. Rename the new dimension set by selecting it, then clicking the Properties button. A Properties window appears.
6. Enter a title for the dimension set in the Caption field and click OK.
7. Continue adding groups and dimension sets to the KPI until the required hierarchy is complete.

Figure 4–28 Hierarchy of Dimensions to Analysis Options

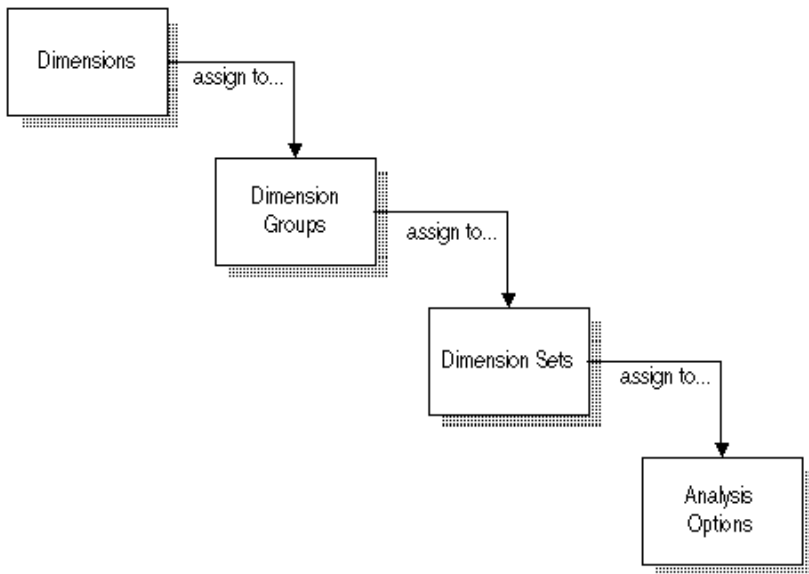

8. Continue adding dimensions to groups until the required dimension set is complete.
9. When you are finished, save your changes by clicking OK.

Moving Dimensions

Dimensions may be moved hierarchically (up and down) within a dimension group. To move dimensions, you must be in the Define Dimensions tab, in the Dimensions Groups panel.

1. Click the dimension you would like to move to highlight it.

2. Click on the same dimension again and drag it to its new location, above or below another dimension.
3. Release the mouse button. The dimension is placed in the new location within the dimension group.

Moving Dimension Groups

Dimension groups may be moved hierarchically within a dimension set. To move a dimension group, you must be in the Assign Dimensions tab, in the Dimension Set panel.

1. Click the dimension group you would like to move to highlight it.
2. Click on the same group once again and drag it to its new location, above or below a current group.
3. Let go of the mouse button. The dimension group along with its specific dimensions will be in the new location on the KPI.

A Note about Moving Dimensions

It is important to note that changing the location of dimensions on a KPI may also affect the List button or dimension relationships. The List button may be affected because in order for the List button to work properly, each KPI must have the dimension that will appear in the List button in the same order (e.g. Region, State, City) from left to right. Dimension relationships may be affected because on a KPI parent dimensions must always be shown to the left of child dimensions. Modifying the location of dimensions should therefore be undertaken carefully due to the potential effects on other KPIs and on the overall scorecard.

Defining Key Items

Define Key Items allows the administrator to define a specific dimension value to be the default dimension setting for that KPI. For example the dimension value "Texas" could be defined as the default for the "States" dimension. Defining "Texas" as the default for the dimension has two consequences:

Note: The key item defined will drive the color in the KPI in the main panel.

1. Texas will be the dimension value that all users will always see when they enter into the KPI.
2. The main view alarm color will be calculated based on the actual vs. plan for Texas. (For example it could be calculated as actual vs. plan for all Products, for all Delivery Types, in Texas).

This option can only be used after dimension values have been loaded into the BSC system. In addition, if a specific dimension value is selected to be the default and no data exists for that dimension value, the indicator color will be gray.

To select a default specific dimension value:

1. From the KPI Designer pop-up menu, select Define Key Items.

Figure 4–29 Define Key Items Window

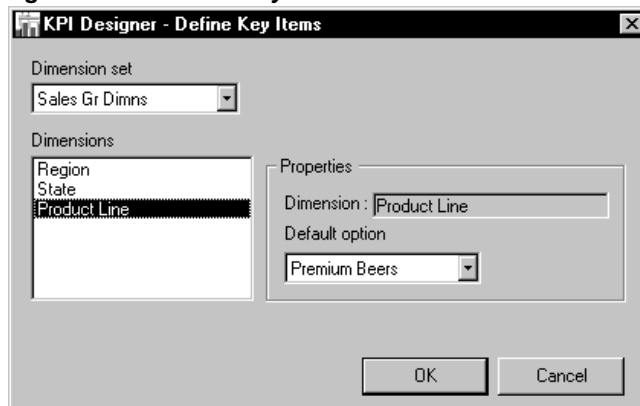

2. If your KPI has more than one dimension set assigned to it you may select the dimension set which you want to modify using the "Dimension set" drop down menu.
3. In the Dimensions pane highlight a dimension for which you want to select a specific value.
4. Using the "Default option" drop down menu select the specific dimension value you want to make the default for the indicator.
5. You may select a new dimension from the Dimension pane and repeat step 4. If your KPI has multiple dimension sets you may also select a new Dimension set and repeat steps 3 and 4.
6. Click OK to save your settings and exit.

Note: Only one of the dimensions in a dimension relationship can be selected to default to a specific value at any one time. For example, if Region is the parent of State you may select a specific value for either Region (such as "South") or State (such as "Texas"), but not for both.

The "DEFAULT <T>" or "DEFAULT <C>" selections in the "Default option" drop-down menu refer to the "Default option" setting defined in the Dimension Group - Dimension Properties window. The <T> indicates that the default for this dimension is a Trend (vertical bar) graph, and <C> indicates that the default for this dimension is a Comparison graph. For more information on the Dimension Group - Dimension Properties window, see "Dimension Properties in Dimension Group" on page 4-51.

Dimension Properties in Dimension Set

The advanced dimension properties window lets you change several properties for the selected dimension. Dimension properties on this screen are indicator-specific and they must be set for each indicator that the dimension is on. This screen allows you control the location of a dimension, its interaction with other dimensions on the KPI, and its ability to be manipulated by the user through the user wizard.

Figure 4–30 *Dimension Properties Window*

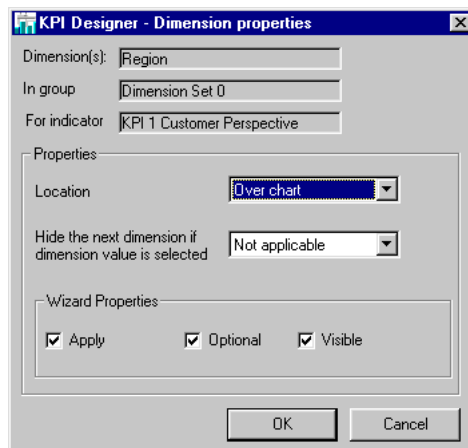

The top part of the screen indicates the dimension that is selected. This is the dimension for which properties are set. The dimension name, dimension set it belongs to, and KPI it belongs to are displayed in the Drill, In group, and "for indicator" fields.

►► **To set the drill properties:**

1. In the Properties region, select the Location where the dimension will be displayed on the KPI window. You can set the location to Over Chart or Top-Right Corner, or you can choose to Hide the dimension from view.
2. Hide the next dimension if dimension value is selected: If a dimension value is selected for this dimension (in this example, the Product dimension), you may hide another dimension that also appears on the KPI. Select the dimension to be hidden using the drop down box. For example, if there are two dimensions on a KPI (Product and Region), whenever the user selects Product B (a dimension value), the whole Region dimension can be hidden. However, if ALL products are selected, the Region dimension will be visible.
3. In the Wizard Properties region, mark or unmark the following checkboxes to change how much control the user has over modifying and displaying the dimension:

Wizard Properties - Apply: Check this box if you want to give the user the ability to modify properties for the dimension selected.

Wizard Properties - Optional: Check this box to make this dimension Optional for the user. If this box is checked, the user will be able to hide and unhide this dimension using the User Wizard.

Wizard Properties - Visible: If this box is checked, the dimension is visible to the user when the user enters the KPI. If this box is unchecked, the dimension is not visible to the user. This property is also referred to as "default visible" since it is setting the default for what dimensions the user can see when he enters the KPI.

Assigning Dimensions Sets to Analysis Options

To establish dynamic dimensions, each analysis option can be assigned it's own set of data dimensions. You must have more than one dimension set available to enable this option.

►► To assign a dimension set to an analysis option:

1. Right-click inside the top left corner of the analysis group for the analysis option. A pop-up menu will appear.
2. Select Analysis Group Properties from the menu.
3. When the properties window appears, select the Modifies Dimension Set checkbox and click OK.
4. Select an analysis option by clicking the option's radio button
5. Right-click in the analysis group panel to display the pop-up menu.
6. From the menu, select Edit Analysis Option. The Analysis Option Properties window appears.
7. In the Dimension set configuration panel, select a dimension set from the pull-down menu. Once a dimension set has been selected, the dimensions included in that set are listed in the Dimension selected field.
8. Click OK to save your changes, or Cancel to cancel.
9. Continue selecting analysis options and assigning them to dimension sets until all analysis options have been assigned.

Note: By default, the first dimension set assigned to the first analysis option will be assigned to the other analysis options.

Dimensions - Notes

- ❑ The maximum number of dimensions in a KPI that can be configured as a Comparison default is 1.
- ❑ A KPI dimension must either default to ALL or Comparison, not to an individual dimension value.
- ❑ A dimension can at maximum have one parent and one child.
- ❑ Parent-child dimensions must be defined from left to right on the KPI (e.g., Region > State > City).
- ❑ You cannot have circular dimensions (e.g., Region > State > City > Region).

Defining Global KPI Settings

Oracle Balanced Scorecard enables you to specify global settings for each KPI, as well as settings for a single analysis option or dataset. Settings include periodicity, calculations, benchmarks, cause and effect relationships, color triggers and user buttons.

Note: This section pertains only to global KPI settings, not to all the KPIs within a balanced scorecard.

Global settings can be overridden by specifying custom settings for individual analysis options. Right-click in the area below the analysis option panels to display a pop-up menu for global settings.

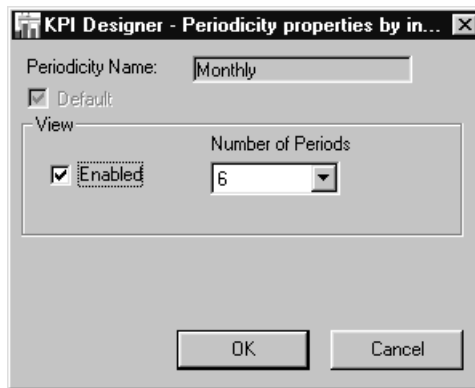
Figure 4–31 KPI Window Main Pop-Up Menu

Periodicity

This feature enables scorecard users to analyze data using a variety of periodicity options. Use the Periodicity panel to select which options will be available with the balanced scorecard. Once selected, these options appear on the indicator window below the analysis groups.

►► To set periodicity options for a scorecard:

1. Right-click in the area beneath the analysis group panels, to display a pop-up menu.
2. Select Define Periodicity to display the Periodicity window.

Figure 4–32 Define Periodicity Window

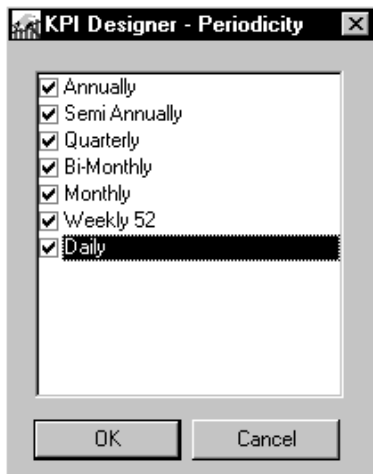

3. Enable or disable periodicity options by clicking the checkbox beside each respective option.
4. When you are finished selecting periodicity options, click OK to save or Cancel to cancel. The options you selected will appear in a panel at the right of the screen beneath the analysis group panels.

Configuration of Period View Scroll Bar (optional)¹

5. Set properties for each periodicity option by clicking the option and holding down the right-mouse button to display the pop-up menu.
6. Select Properties to display the Periodicity Properties window. If you have defined non-annual periodicity, the Periodicity Properties window appears this way:

¹ If the user does not do these steps, the BSC Viewer will show all the periods default.

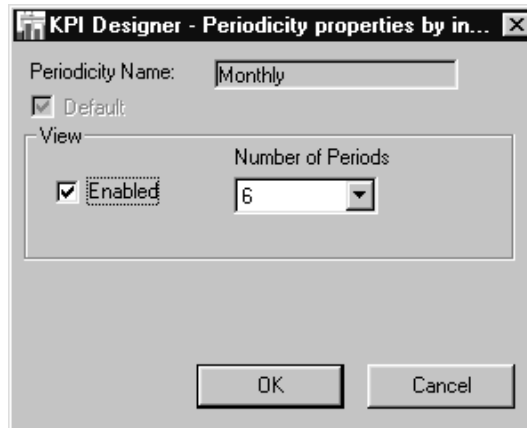
Figure 4–33 *Periodicity Properties Window, Non-Annual Periodicity*

If you have defined annual periodicity, you will see the Periodicity Properties window.

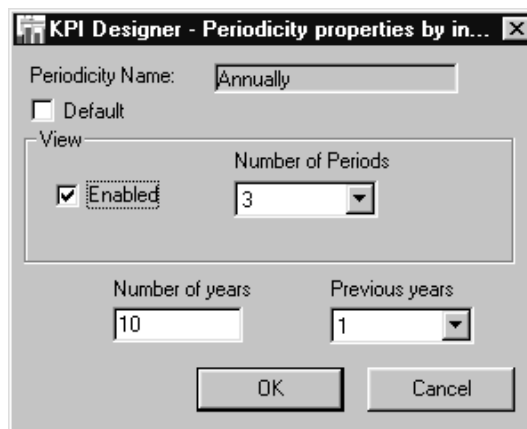
Figure 4–34 *Periodicity Properties Window, Annual Periodicity*

Default: Define this periodicity as the default periodicity.

Enabled: Enable the optional period view scroll bar. When enabled, the period view scroll bar appears in KPI view and lets you control the number of periods that display at one time in a KPI graph.

Number of Periods: Number of periods visible in the graph at the same time.

If you are setting properties for the periodicity named Annually, enter the following additional fields, which are needed because the annual periodicity does not have a fixed number of periods:

Number of Years: The number of years available.

Previous Years: The number of previous years.

Example 4-5 Six Periods Defined, Period View Scroll Bar Enabled

If the number of periods is defined as six, then the KPI graph will show six months at a time. A scroll bar at the bottom of the KPI screen lets you see the other six months. You can also use the period scroll bar to control the number of periods that display at once.

Figure 4-35 Using Periodicity Properties to Enable the Period View Scroll Bar

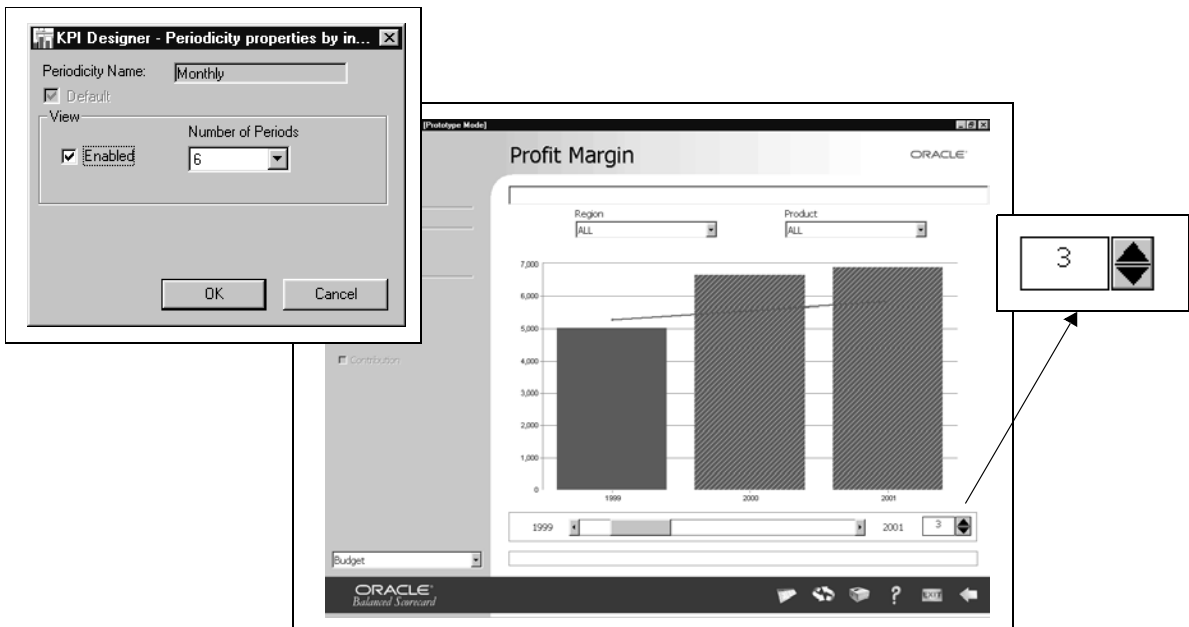

7. Click OK to save your changes or Cancel to cancel.

Calculations

The Calculations feature offers a variety of standard calculations which you, as the person who is designing the balanced scorecard, can activate for scorecard users. Once activated the Calculations options appear on the right side of the window below the analysis group panels.

►► To activate calculations for the scorecard:

1. Right-click in the area beneath the analysis group panels to display a pop-up menu.
2. Select Define Calculations. The Calculations window appears.
3. Enable or disable calculations by clicking the checkbox beside each calculation option.

Note: Individual calculations can be disabled for individual analysis options. See "Setting Properties for a Dataset" on page 4-23.

Figure 4-36 Calculations Window

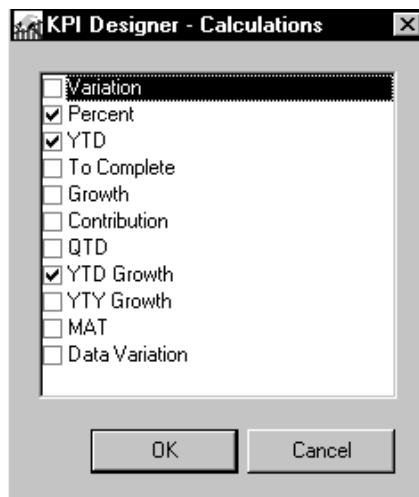

- **Variation:** Shows the amount that actual results vary from the benchmark.
- **Percent:** Shows the actual results as a percentage of the benchmark.

- **YTD:** Shows the accumulated results for the current year.

Note: In the KPI view for balance accounts such as total assets, YTD will be disabled since it does not apply.

- **To Complete:** Calculates the previous period and actual period relative to the plan. The difference between accumulated results and the targeted goal is then distributed equally over the remaining periods. This gives a picture of the challenge ahead by showing the results yet to be achieved towards the targeted plan.
 - **Growth:** Shows the percentage change between the preceeding period and the current period.
 - **Contribution:** This calculation is only available for comparison graphs. Shows how much each data dimension element contributes to the total results for that dimension.
 - **QTD:** Results for the quarter to date
 - **YTD Growth:** Compares the current period versus the last period of the previous year (final results for the previous year). For example, March 1999 is compared versus October 1998, the last fiscal month of the previous year.
 - **YTY Growth:** Calculates the growth between the current period versus the same period in the previous year.
 - **MAT:** Shows the moving average for the last twelve months. Taking the average of the last twelve months shows a smoothed trend that lets you analyze results without monthly deviations.
 - **Data Variation:** This calculation is used for multiple bar indicators. The amount of variation between any two series in the same period is calculated.
4. Click OK to save your changes or Cancel to cancel.

Year to Date Calculation as the Default Entry Method

The Year to Date (YTD) calculation can be set as the default entry method into the KPI. This means that when users enter the KPI the YTD calculation will be automatically selected. Selecting YTD as the default method will also cause the alarm colors on the main views to be calculated as Total YTD Actual vs. Total YTD Plan.

1. You must have YTD as an active calculation already on the KPI. If it is not there, add it
2. Right-click on YTD, and select Calculation Properties.
3. In the Calculation Properties window, select the Default checkbox to make YTD the default entry method into this KPI.
4. Click OK to save.

Note: You can only choose YTD as the default calculation. If the current data set does not have YTD as a calculation, this option is not available. For instance, for balance accounts such as total assets, YTD calculations will be disabled.

Benchmarks

Oracle Balanced Scorecard uses benchmarks to calculate the status of an indicator. Two default benchmarks are included with every scorecard:

Budget: The default benchmark for calculating alarm colors. It is defined as Data Type 1. This benchmark is populated with user-defined data, and can be renamed if necessary.

Previous Year: Previous Year compares actual results with results from the previous year. Oracle Balanced Scorecard also lets you define custom benchmarks.

For all balanced scorecards, the KPI alarm colors shown in the main window are always calculated as your actual data compared against the benchmark Data Type 1—by default, the Budget benchmark.

►► To define a benchmark:

1. Right-click in the area beneath the analysis group panels, to display a pop-up menu.

2. Select Define Benchmarks to display the Benchmark Settings window. The left panel shows a list of available benchmarks. The right panel shows a list of the Selected benchmarks.

Figure 4–37 Benchmark Settings Window

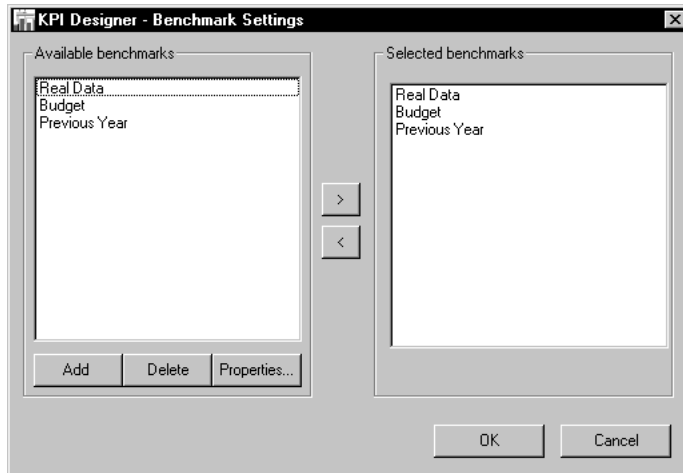

3. To add a benchmark to the list of Available benchmarks, click Add.
4. Give the new benchmark a title by clicking Properties. The Benchmark Properties window appears.

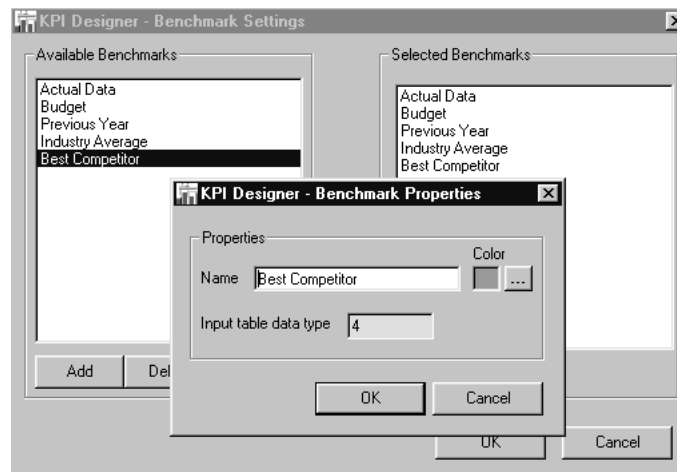
Figure 4–38 Benchmark Properties Window

5. In the Name field, enter a title for the benchmark. The Data type field displays a number which is automatically assigned to the benchmark. This number is used by the database.
6. Click the Color button to display a color palette. Select a basic or custom color for the benchmark line and click OK. The Data type field displays a number which is automatically assigned to the benchmark. This number is used by the database to specify data corresponding to this benchmark.
7. Repeat steps 2 through 5, to create additional benchmarks as required your balanced scorecard specification.
8. If you wish to remove a benchmark from the Available benchmarks list, click Delete. You cannot remove, Actual, Budget, or Previous Year since these are system defaults. If you try to remove Budget, the system gives you a warning since this will effect the color of the KPI's alarm box.
9. Select a benchmark to include with the current indicator by highlighting a benchmark in the Available benchmarks panel and clicking the right arrow button. A copy of the benchmark is moved to the Selected benchmarks panel.
10. Continue selecting benchmarks and moving them to the Selected benchmarks panel until all the required benchmarks have been selected.
11. If you wish to remove a benchmark from the selection list, click the left arrow button.

Fiscal Year and Month

Because the fiscal year varies from organization to organization, it's important to define this setting for each new balanced scorecard you create. All time periods in BSC are based on the fiscal year. For example, fiscal year 1999 beginning June means June 1998 to May 31, 1999.

►► To define fiscal year and month:

1. Right-click in the area beneath the analysis group panels to display the pop-up menu.
2. Select Define Fiscal Year to display an editing window.
3. Enter the current fiscal year and use the Beginning of the fiscal year pull-down menu to select a month.

Figure 4–39 Define Fiscal Year and Month Window

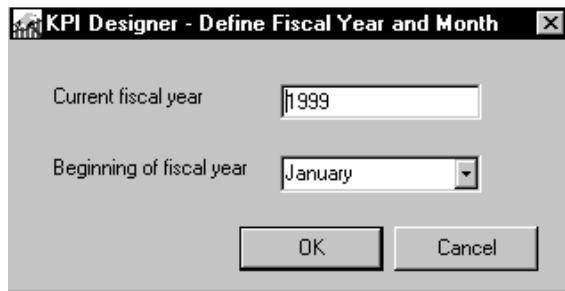

4. Click OK to save your changes or Cancel to cancel.

Cause and Effect

Scorecard users can click the Cause-Effect button in an indicator window to display a Cause and Effect Matrix. This matrix shows the relationship of the current indicator to the other balanced scorecard indicators. Cause Indicators are listed in the left-hand column. These are indicators that influence the status of the current indicator. Effect Indicators are listed in the right-hand column. The status of the Effect indicators is influenced or effected by results for the current indicator.

By analyzing the cause and effect relationships between indicators, it's possible for users to understand which variables are responsible for current results. This information is also important when devising strategies for resolving organizational problems.

When designing balanced scorecards, it's important to think carefully about the relationships between indicators. The effectiveness of the Cause-Effects Matrices as an analysis tool depends on accurate assessment and documentation of these relationships by the scorecard designer. Cause and Effect is one of the most important features in the balanced scorecard theory and to define it, a previous conceptual process needs to be developed to come up with a complete Cause and Effect scorecard model.

Figure 4–40 Cause and Effect Indicators

Cause Indicators	Effect Indicators
Product Availability	Product Line Profitability
Top of Mind	Return on Equity
Quality Assurance	
Price Gap	

Note: You cannot select an indicator to be a cause or an effect of itself.

►► To define cause and effect relationships for an indicator:

1. Right-click in the area beneath the analysis group panels, to display a pop-up menu.
2. Select Define Cause and Effect to display the Cause and Effect editing window.

Figure 4–41 Cause and Effect Editing Window

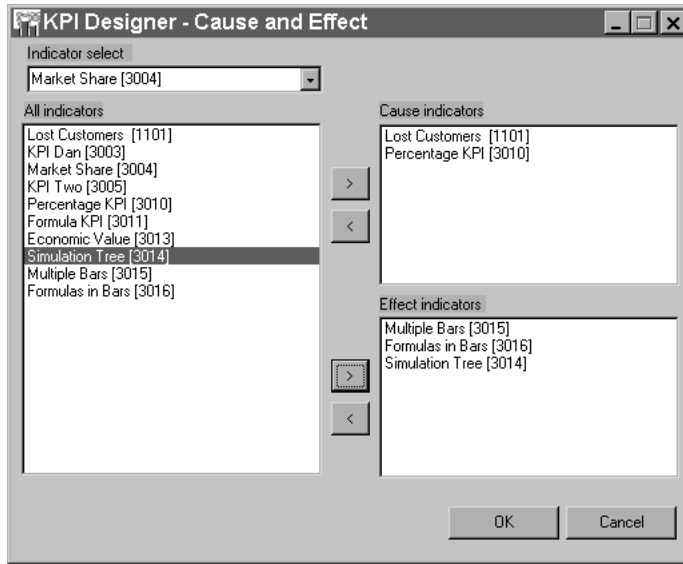

3. Use the Indicator Selected pull-down menu to select an indicator. The All indicators panel displays a list of all the available indicators. The Cause and Effect indicator panels show lists of cause and effect indicators.
4. Move items to the Cause indicator panel by highlighting an item in the All indicators panel, then clicking the right arrow button beside the Cause indicators panel. The item is now listed with the Cause indicators.
5. To remove an item from the Cause indicator panel, click the left arrow button.
6. Move items to the Effect indicator panel by highlighting an item in the All indicators panel, then clicking the right arrow button beside the Effect indicators panel. The item is now listed with the Effect Indicators.
7. When you are finished selecting cause and effect indicators, click OK to save your changes or Cancel to cancel.

Alarm Colors

The alarm colors in Balanced Scorecard denote when and by what margin a value in the Scorecard deviates from the planned value. For instance, you can define a trigger value for any KPI (such as ROE) at which that KPI's color will change if the trigger value is reached. For example, if you were targeting an ROE of 20%, and you set a trigger to this value, the color of the KPI would change if your ROE fell below 20%.

The definition of trigger values (and percent deviation from these values) is one of several factors determining the alarm color. These factors include:

- How the color trigger is defined (what value)
- How the default analysis option is defined (monthly or year-to-date)
- How dimension properties are defined (all, comparison or modified comparison)
- How the color method is specified (target met above plan, target met below plan, or target met between ranges)
- Prototype color (during prototype stage only)
- User-customization of default colors (other than red, yellow and green)

Color Triggers Color triggers are threshold values (percents of planned performance) at which alarm colors are defined to change in the KPI view panel. This is done to alert the user that that KPI's actual performance deviates from planned performance by the specified percent of plan.

►► To define the threshold of a color trigger:

1. In KPI Designer, click on the tab containing the KPI whose trigger you want to modify, then click the box beside that KPI to launch the KPI window. In the KPI window, right-click in the area below the analysis options to bring up a pop-up menu. From this menu, select Define Color Triggers to open the color trigger definition window:

Figure 4–42 Define Color Triggers Window

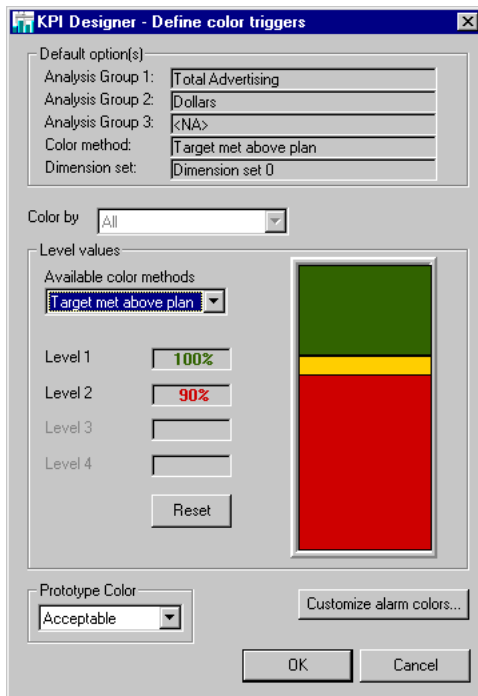

2. Position the cursor over a color threshold's boundary line on stoplight panel. The cursor turns to a double-arrow.

3. Hold down the left mouse button over the boundary line and drag up or down to adjust the color level. The percentage value in the Levels field changes to reflect your adjustment.
4. Continue adjusting the color trigger levels to reflect your balanced scorecard specification.
5. When you are finished, do one of the following:
 - Click Okay to save your changes and close the editing window.
 - Click Cancel to cancel your changes and close the editing window.
 - Click Reset to restore the previously saved settings and leave the editing window open.

Definition of Default Analysis Option Alarm colors are driven by how you have defined the default analysis option (see "Analysis Options" on page 4-20 for a detailed description of this process). The default options can be defined as:

- Monthly: The color will apply to the data for that particular month.
- YTD: The color will apply to the data for the year to date (for instance, Sales YTD through the month of June, as opposed to Sales *during* the month of June).

Note: The YTD check box in KPI view is automatically disabled in Balance accounts since it does not apply there.

Definition of Dimension Properties Alarm colors are also influenced by how dimension properties are defined. The default value for any dimension can be All, Comparison or a specific dimension value or item (such as "Texas" for a States dimension).

"All" and Item For "All" and item dimension values, the main view color reflects actual vs. benchmark for the dimension values shown on the KPI screen when the user enters the KPI.

Comparison The "Color By" drop down list is only active if one of the KPI dimensions is set to default to "Comparison". If this is the case, this drop down lets you select how the view alarm color will be calculated. If you select "Minimum Common Color", the alarm color will be calculated based on the minimum common color method. This is the standard comparison color method.

When selected, the comparison method calculates a color for each value within a dimension, then defines the view alarm to be the least common color among those dimension value colors. For example, if one dimension value is calculated yellow and all others are calculated green, the KPI's alarm color will be yellow. Each dimension value is calculated as actual vs. benchmark against the percentages defined for that particular KPI. This affects alarm colors in the following ways:

- If any dimension value is red, the KPI color on the main view is red.
- If any dimension value is yellow and not red, the KPI color on the main view is yellow.
- If all dimension values are green, the KPI color on the main view is green.

If you select "All", the alarm color will be calculated based on the dimension total. This is the same as having the dimension default to ALL, and is called the "Modified Comparison" color method.

Modified Comparison The Comparison dimension can be configured by the administrator to calculate the alarm view color based on actual vs. benchmark for the "All" value for that dimension. This is an alternative for clients who like the comparison mode, but find that the "least common color" method is not satisfactory. The administrator should take care to educate users on how the KPI will be calculated because this is the ONLY exception to the rule stating that whatever analysis option and dimension values the user first sees on the KPI is how the alarm color is calculated.

Combining Methods On any one KPI, the above methods may be combined, with some restrictions to maintain the integrity between dimension parent-child relationships. The KPI Designer will automatically maintain the proper restrictions in the system as a KPI is being build or modified. With the one exception listed above, the cardinal rule always applies that the view alarm color is ultimately calculated by the default values - the values that the user sees when first entering the KPI.

Other Notes \ If BSC contains KPIs that are updated with actual at different times, the alarm colors will reflect these different actual periods. For example, if KPI 1 was last updated in March, and KPI 2 was last updated in April, the alarms will be based on these respective months.

- ❑ If a KPI has several periodicities, the alarm color will be based on the default periodicity.
- ❑ KPI Alarm colors are always calculated on actual data vs. the benchmark coded "1" (in the KPI Designer) which is defaulted as plan. It is not possible to calculate alarm colors against other benchmarks.
- ❑ The name of the Code 1 benchmark may be changed in the KPI Designer, but the name is global across all scorecards and not KPI-specific.
- ❑ When no benchmark data has been loaded for a KPI, its default alarm color is dark gray. Should you want to change this color default, you can do so by choosing Define Color Triggers > Customize Alarm Colors from the main pop-up menu.
- ❑ When having a benchmark is not appropriate for a KPI, all benchmarks can be removed from the KPI, and the default view color will be light gray.
- ❑ For multiple bar KPIs, the alarm color is based on the default data series, which is the series the BSC Viewer will always show first when a user goes into the KPI. This default can be set by the administrator. In order to have an alarm color for a multiple bar KPI, the default series must have Code 1 benchmark data.
- ❑ If a KPI is modified in production mode, it can affect the alarm color. You may have to run Loader again after modifying a KPI to reactivate its color. KPIs that have been modified in production mode may appear in light grey until Loader is rerun.

Calculating color for trend graphs: If the default setting for a KPI is a trend graph, then the alarm color is calculated by taking the current month's actual data versus the plan for the first dimension and default analysis option combination. The system then uses the color trigger percentages to calculate the correct color.

Calculating color for comparison graphs: If the default setting for the indicator is a comparison graph, then the color is determined by using the color trigger percentages to calculate a separate color for each dimension value (each bar on the comparison graph) for the default analysis option combination of the comparison dimension. For default alarm colors of red, yellow and green, the colors are reported as follows:

- If any dimension value is red, the KPI color on the main panel is red.
- If any dimension value is yellow and not red, then the KPI color is yellow.
- If all dimension values are green, then the color is green.

Calculating color for simulation trees: If the default setting for the indicator is a simulation tree, the color is determined by comparing actual to planned performance for a specific node of the tree that you choose.

Definition of Color Method The third factor influencing the appearance of alarm colors is the definition of color method. The color method can vary depending on the type of KPI and the configuration of the KPI view (trend or comparison).

►► **To define a color method:**

1. Select the default option for the analysis group by clicking its radio button.
2. Right-click in the area beneath the analysis group panels, to display a pop-up menu.
3. Select Assign Dataset.
4. In the Assign Datasets window, click the Properties button.
5. Select the Dataset Properties tab to bring it forward.
6. In the Properties panel, select an indicator color method.
 - **1-Target Met Above Plan:** The green (or user-specified) color shows when actual results are above the plan for targeted values. Example: revenues or sales.
 - **2-Target Met Below Plan:** The green (or user-specified) color shows when actual results are below planned values. Example: Production costs, employee turnover.
 - **3-Target Met Within Ranges:** Green (or user-specified) color shows when actual results are between specified range values. Example: Inventory. Click OK to save changes

Note: Only the color methods defined in the indicator will be shown in the Available Color Methods poplist.

7. Click OK again to save your changes and close the Assign Data set window.
8. Right-click in the area below the analysis group panels to display the pop-up menu and select Define Color Triggers. The Define Color Triggers editing window appears. The top panel, shows the selected color method for the default analysis options in each group. This information describes how the alarm color for the indicator will be displayed on the main window.

In the lower panel, the Available color methods pull-down menu displays the color methods that have been assigned to the KPI by evaluating *all* datasets. The Level fields shows the percentage at which the various color levels are triggered.

Note: Only the default alarm color method, identified in the top part of the window, will affect the alarm colors on the main panel.

Prototype Color The Prototype color drop down list is only used during the prototype stage of a BSC system, before actual data is loaded into the application. Using this drop down list the KPI alarm color on the main view can be set while in prototype mode only. This facilitates presentation and provides for a more consistent demonstration of the product. In addition, the default KPI window settings (actual vs. plan) will be set by the application to match the alarm color on the main view.

Figure 4–43 *Prototype Color Menu*



User-Customization of Alarm Colors If the user wants to modify the default alarm colors (red, yellow and green), he/she can customize alarm colors using the "Customize alarm colors" button. To access this feature:

1. Within a KPI, right-click the open area to the right of the KPI graph control panel and choose "Define Color Triggers" from the pop-up menu.
2. Click the "Customize alarm colors" button. The Customization window appears.

Figure 4-44 Customizing Alarm Colors

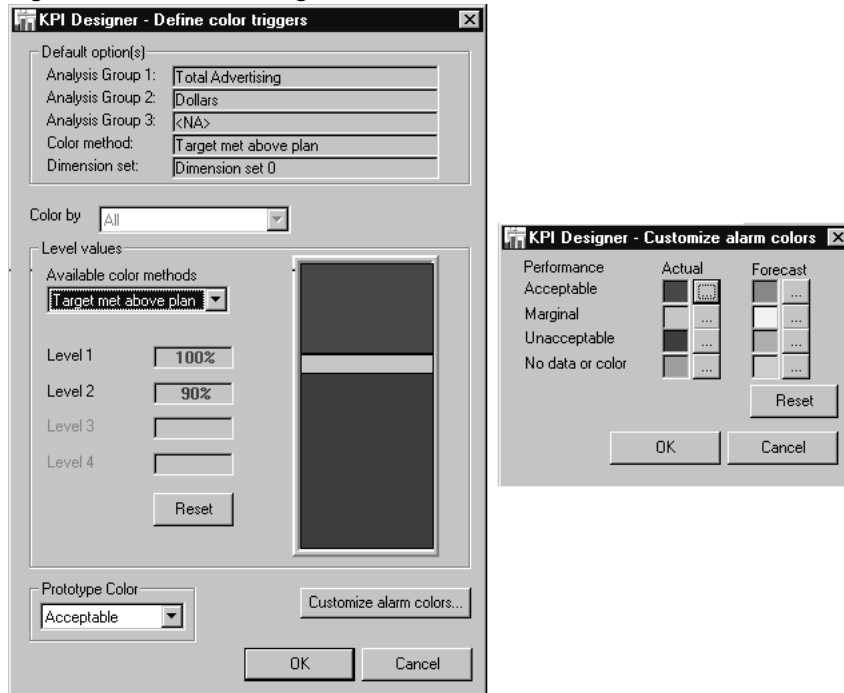

3. You can select colors for actual and forecast periods. Use the Acceptable row for above plan, the Marginal row for slightly below plan, the Unacceptable row for below plan and the No Data or Color row for no data. When you have chosen your colors, click OK.
4. Click OK again to close the "Define color triggers" dialog box.

Now your color triggers should display with your custom color configuration.

Note: Be aware as designer of the system that the default alarm colors reflects the traditional traffic light approach: Green, Yellow and Red. If new alarm colors are customized you are changing this paradigm and it will be necessary to communicate the new meaning of colors to the organization.

Specifying User Buttons

This feature enables you to specify which user buttons will be activated for a balanced scorecard. Access the User Buttons panel by right-clicking in the-area below the analysis group panels. When the pop-up menu appears, select Specify User Buttons. The set of available buttons is as follows:

- **Messaging:** Enables e-mail access.
- **Custom help:** Provides access to multimedia help and other on-line support tools.
- **Exporting to Excel:** Exports data from the current indicator window to an Excel spreadsheet.
- **Link Options:** Allows the user to launch a designated application.
- **Projection:** Enables the user to turn on or off the projection bars in the indicator window.
- **User Wizard:** Enables the User Wizard. This wizard allows users to customize their view of their individual scorecards.

Messaging

This functionality is being reviewed for implementation in future releases. It is not yet available.

Custom Help

The Custom Help feature gives users access to multimedia help and other on-line support or education tools via URLs that can be defined to be launched in the Viewer. The different Links configured in this section will be available in the Indicator page in the Viewer as links that can be accessed by the end user.

Configuration of Custom Help

►► To enable the custom help feature:

1. In the User Buttons window, check the Custom Help check box.
2. Click Properties to display the Custom Help settings window.

Figure 4–45 Custom Help Settings Window

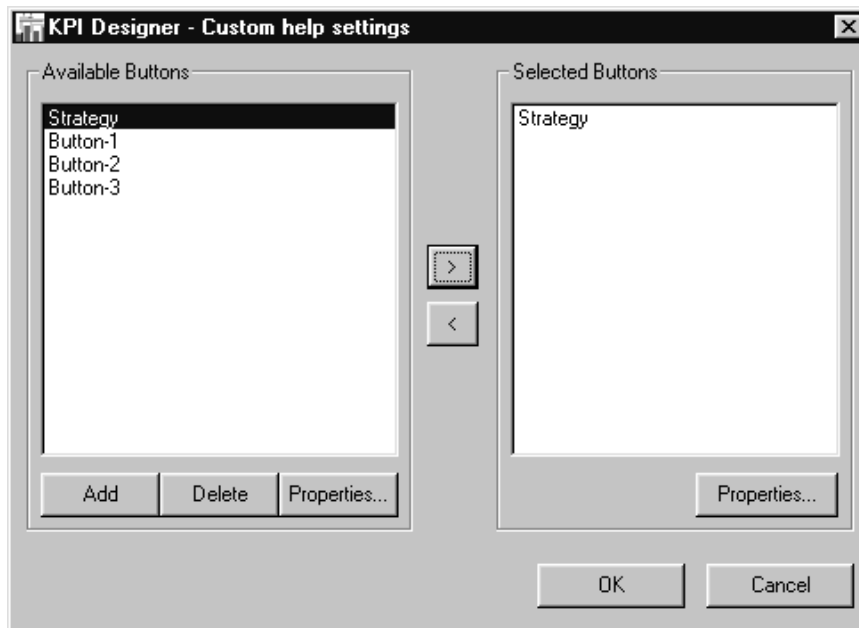

3. To add a button to the Available buttons pane, click Add. A blank button is added to the list.
4. Click Properties to edit the new button's properties.

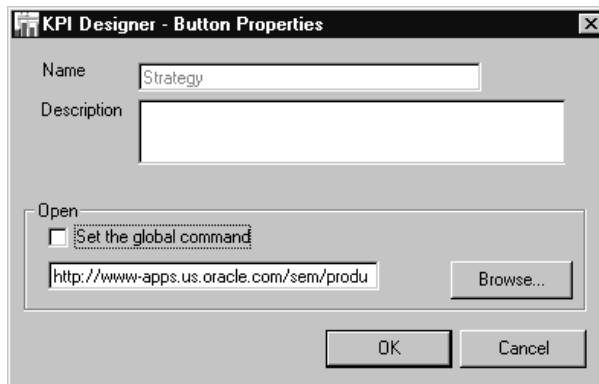
Figure 4–46 Custom Help Button Properties

5. In the Button Properties window, enter a name for the button in the Name field.
6. Enter a text description of the button's function in the Description field.
7. Configure the file or URL you want to launch from each button giving the URL address where the file resides. Usually files must reside in the Web server. But for local demo purposes you could also define a local HTML page with local links to your local files.
8. Click OK to save your changes, or Cancel to cancel.
9. Use the arrows to move the buttons you just defined from the Available Buttons region to the Selected Buttons region. The buttons in the Selected Buttons region are those that will be available to users as Links.
10. Choose the Properties button.
11. Repeat step 7 to select the executable to be launched.
12. If you want to use the global command executable for the button, check the Select the Global Command checkbox. This will put the file defined in the command list as the file to be launched for this button.

Note: The Custom Help can only be launched from the BSC Viewer browser window.

Note: For both Links and Custom Help, the user must have the required plug-ins to be able to open the files to be launched.

Exporting to Excel

Activating this button allows the end user to export data from the current indicator window to an Excel spreadsheet. At design mode the consultant or designer must decide which indicators are relevant for the end user to enable this function. The user button has to be enabled per Indicator.

To enable this property, right click on the KPI designer main menu, enable the "Define User Buttons" option, and then use the check box next to "Export to Excel" to enable this option in your indicator.

There is no need to set properties or path names since the software automatically accomplishes this function. For more information on how data is exported in the Viewer, see the "Export Data To Excel" section of the *Balanced Scorecard User Guide*.

Link Options

The Links feature makes it possible to launch a URL while working from within Oracle Balanced Scorecard. It is possible to configure a single or several different URLs to launch using the Links button.

▶▶ To enable the Links button:

1. In the User Buttons window, check the Links check box:

Figure 4–47 User Buttons Options Screen



2. Click Properties to display the Links Properties window.

Figure 4–48 Link Properties Window

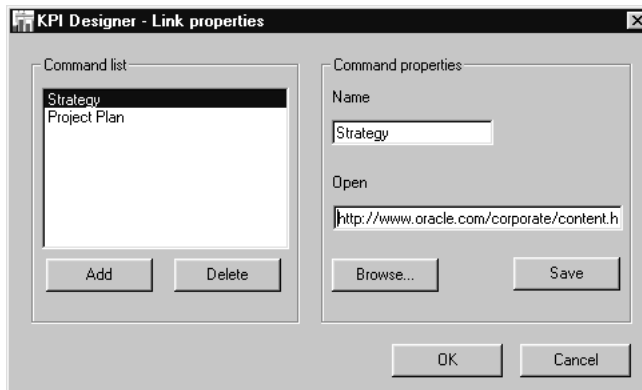

3. Click the Add button in the Command List panel to add a new link or URL.
4. In the Command Properties panel enter a name for the URL you wish to add.

5. In the Open field, enter the URL.
6. Click Save to save your changes, or Cancel to cancel. When you save a link, it is stored in the links list and can be accessed later through the BSC Viewer Links section.
7. Continue adding links until all the required links are configured.
8. Click OK to save your changes and close the Link Properties window, or click Cancel to cancel your changes and close the window.

With the Links feature enabled, the end-user will have access to the Links section in the BSC Viewer with all the URLs you have defined.

Projection

Activating the Projection button enables the user to temporarily turn off the forecast bars which are calculated internally by the system and display only actual data.

Note: This functionality is available for the end user in BSC Viewer only if you enable the "Projection" user button in your indicator. Remember this must be enabled or disabled per Indicator, it is not a global property.

User Wizard

The User Wizard is the tool that allows configuration of shared KPIs. You can use this wizard to hide or show options previously defined in a master KPI (see "Configuring Master and Shared KPIs"). Check the User Wizard checkbox in the User Buttons window to enable this feature.

►►To configure indicators with the User Wizard:

1. Enter the tab containing the KPIs whose analysis groups and options you want to configure.
2. Enable the User Wizard by right-clicking and selecting Define User Buttons. On the User Buttons screen, check User Wizard to enable the button. When you exit this screen, you should see the User Wizard button. Click the button to launch the wizard.
3. Click Next to show the Analysis Group window. Use this window to select the options you want to configure. When you select options, you will be able to

change the configuration of its dependent dimensions, periodicity and calculations on subsequent screens.

Figure 4–49 *User Wizard, Parent Options Window*

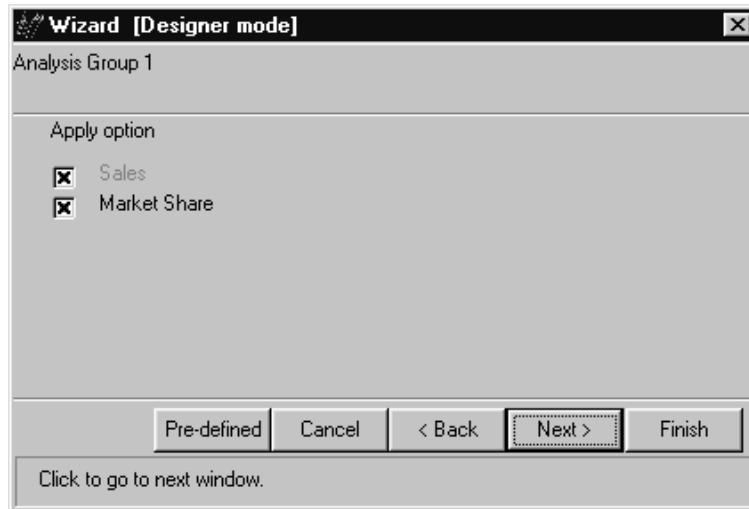

4. For each option in the analysis group on the tab, select the dependent options to expose. Use the Dependency window to scroll through each option in the group, selecting and deselecting options.

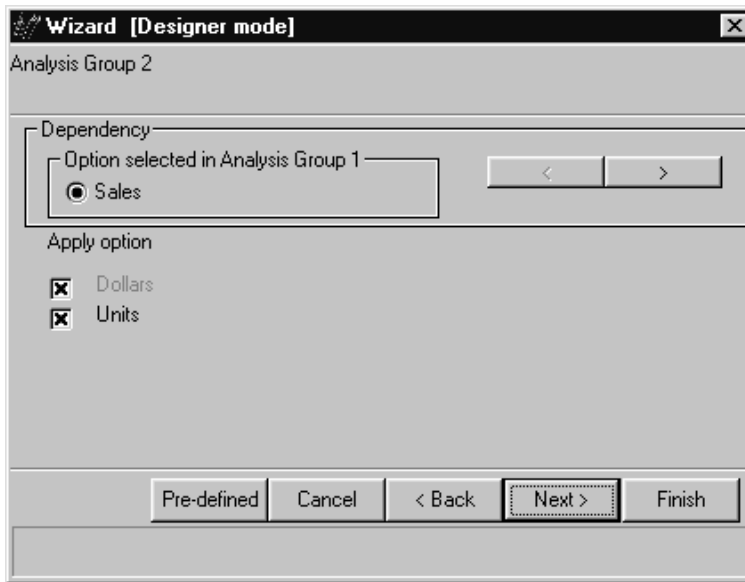
Figure 4–50 User Wizard, Child Options Window

5. Click Next to select the periodicity options you want to hide or show in this Indicator for this tab. Depending on your selections, you can show multiple options for the same KPI. For instance, the same KPI could be displayed with monthly, quarterly or annual data by checking or unchecking the boxes that will be exposed depending on your selections in this screen.

Figure 4–51 User Wizard, Periodicity Options Window

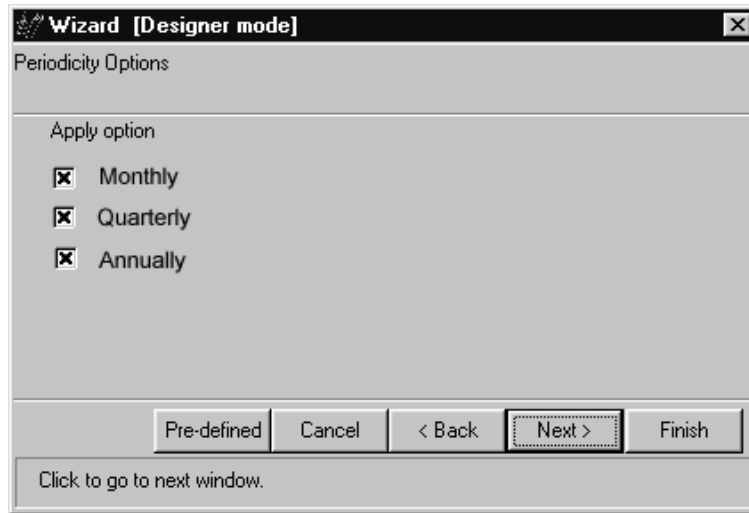

6. On the next screen, you can select the calculations that you want to show or hide in this tab from the set of calculations configured for the Master KPI. Contribution calculations will only be enabled in a comparison (trend) graph.

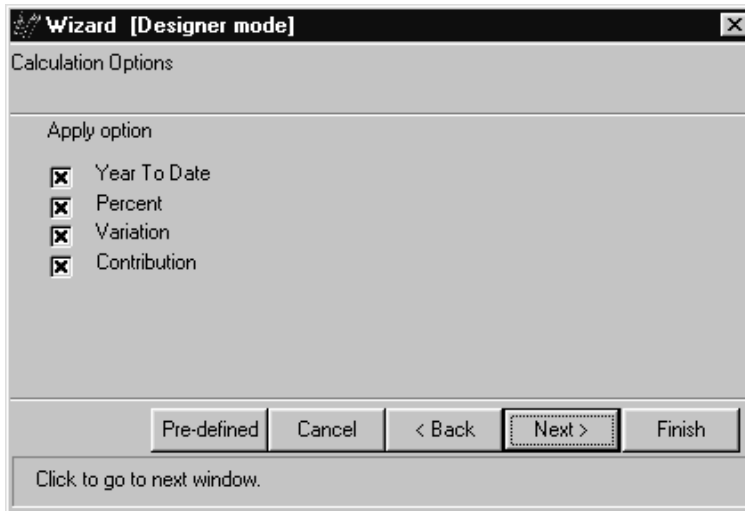
Figure 4–52 User Wizard, Calculation Options Window

7. On the next screen, you can select the dimension levels that you want to show or hide from the set of dimensions configured for the Master KPI. Note that if dimensions are unexposed, you can still drill to them by clicking on a series in the KPI screen. The options you apply on this screen determine which options appear in the pull-down menu for dimensions on the KPI window for that KPI.

Figure 4–53 User Wizard, Dimension Level Options Window

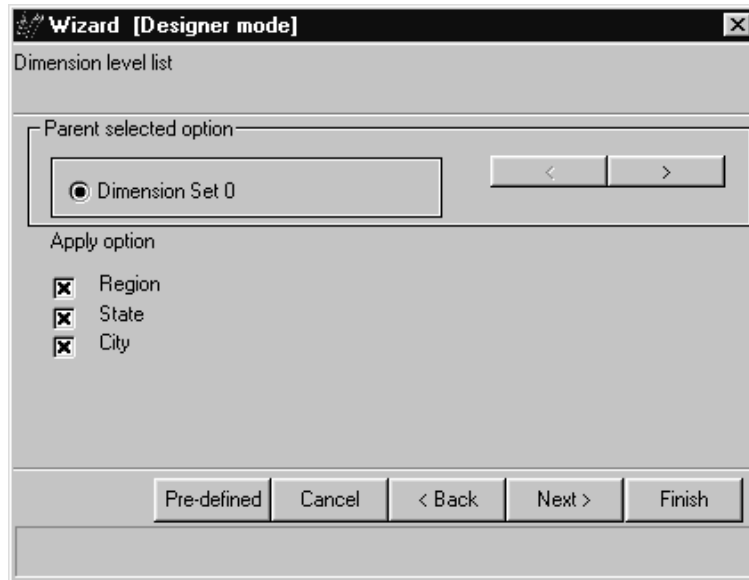

8. Repeat this process for all tabs and KPIs whose analysis options you want to configure.

Creating What-If Simulations

What-if Simulation KPIs enable Balanced Scorecard users to simulate the impact of changes in indicator performance on overall results. They are usually associated financial indicators. Simulation indicators must be defined in the BSC Builder at the time the KPI is created.

A “what-if simulation” or simulation tree uses nodes to represent data variables and directional lines to map out the relationship between variables and overall performance.

Note: Nodes are not necessarily KPIs, but can be if so defined.

Indicator nodes must first be created and labelled, then moved into position on the indicator window. Once the nodes are positioned, directional lines can be added to show the relationship between them. If you wish to include data dimensions or

other settings for the simulation tree, these must also be defined. A navigation feature allows users to click an indicator node to see a graph representing data for the node. As the scorecard designer, you choose whether to enable this feature. Finally, datasets must be assigned to the simulation tree and formulas defined for each node.

The Simulation KPI works by defining two types of nodes:

- **Source nodes:** Nodes that represent raw, or not calculated, data. These nodes can be changed by the user during Simulation using a scroll bar to simulate higher or lower values. To populate these nodes with raw data, datasets are assigned to nodes. These datasets are identical to the datasets used for analysis options - they specify data sources and requirements. When actual data is entered into the system, these datasets will be populated with data, and since a node is always assigned a dataset, the node will represent that actual, raw data.
- **Formula nodes:** Nodes calculated based on the Source nodes. These nodes cannot be directly changed by the user; they respond to the changes made in the Source nodes.

What-if simulations for large scorecards can become quite complex. For this reason, designers often find it helpful to diagram a proposed simulation tree on paper before beginning the design process in Oracle Balanced Scorecard.

▶▶ To set up a simulation indicator window:

1. In the KPI Designer main window, click a simulation indicator to display the indicator's window. A blank simulation window appears showing a sample node, data dimension and analysis option.

Figure 4–54 Financial Simulation Window

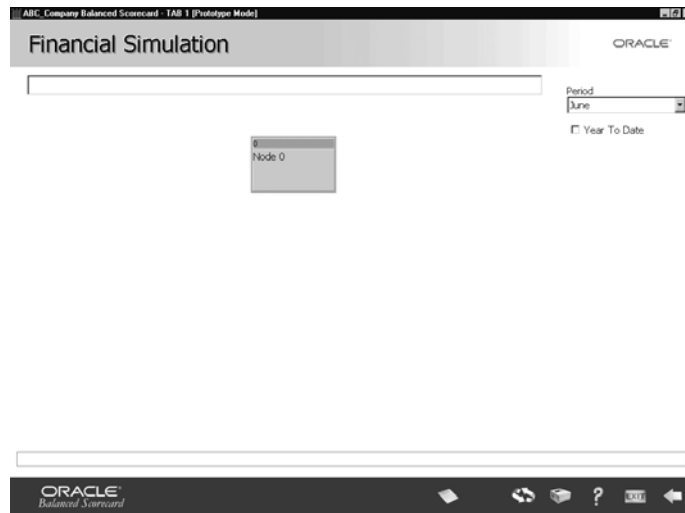

2. Enable drag and drop mode by right-clicking to display the pop-up menu and selecting Enable Drag Drop Mode.
3. Add a node by displaying the pop-up menu and selecting Add Node. The Add Node window appears.
4. Enter a Name and Description for the node.
5. Check the Apply color using benchmark checkbox to apply color to the benchmark.
6. Select a numerical format from the Sample format pull-down menu.
7. Select a Color method from the pull-down menu.
8. Click OK to save your changes, or Cancel to cancel.
9. Create all the nodes needed for the simulation window. Newly created nodes are stacked in the upper left corner of the window. You will drag them to their desired location in subsequent steps.

10. Right-click in the area to display the pop-up menu and select Enable Drag Drop Mode.
11. Arrange the nodes to your preferred layout by holding down the left-mouse button on the top node in the stack and dragging it to the desired location.
12. Once the nodes are arranged click the save icon to save your changes. If you forget to save before making further formatting changes, your layout will be lost.
13. Add directional lines and labels as needed. Display the main pop-up menu and select a formatting option.
 - **To add a vertical line:** From the pop-up menu, select Add Vertical Line. A line appears on the window. Click directly on the line to display another pop-up menu and select Edit Line Properties. Use the editing window that appears to edit the size and position of the vertical line.
 - **To add a horizontal line:** From the pop-up menu, select Add Horizontal Line. Use the instructions provided above to adjust the size and position of the line.
 - **To add a label:** From the pop-up menu, select Add Label. A blank label appears on the screen. Click the label to display a pop-up menu and select Edit properties. Enter a caption for the label and click OK. Enable Drag Drop Mode, then drag the label to the desired location.
 - **To add an arrow:** First, add the vertical or horizontal line, as described above. Double-click on the line to open the Line Properties window. At the bottom of this window, select the Up or Down arrow option.
14. If you wish to include dimension sets with the simulation indicator, right-click to display the pop-up menu and select Define Dimension and Dimension Sets. Assign dimensions sets to the simulation window. Click OK to save your changes.



Note: When a simulation tree contains a dimension with Comparison as a default property and "No ALL or Item", the color will be calculated as "ALL or Item" taking the formula defined between datasets.

15. From the main pop-up menu, select Define periodicity to set periodicity options for the simulation window. Define periodicity options for the simulation indicator.

Note: The simulation indicator supports only one periodicity at a time.

16. From the main pop-up menu, select Define Calculations to select calculations for the simulation.
17. From, the main pop-up menu select, Navigation to enable the navigation feature. This allows users to click a node to display a graph showing node data.
18. Before assigning datasets to nodes, you must first define the available datasets for this Simulation KPI. To do this, see "To define available datasets for a simulation KPI:" on page 4-95.
19. Click the Datasets button to add required datasets to the simulation tree.
20. In the Simulation Tree Dataset window, select datasets to use in the simulation tree. Click OK to save your changes.
21. In the Data Assign and Formula Definition window, create formulas for each node. Click OK to save your changes.

▶▶ To define available datasets for a simulation KPI:

1. Display the Data Assign and Formula Definition window by clicking Assign Data and Formulas in the main pop-up menu.

Figure 4–55 Assign Data and Define Formula Window

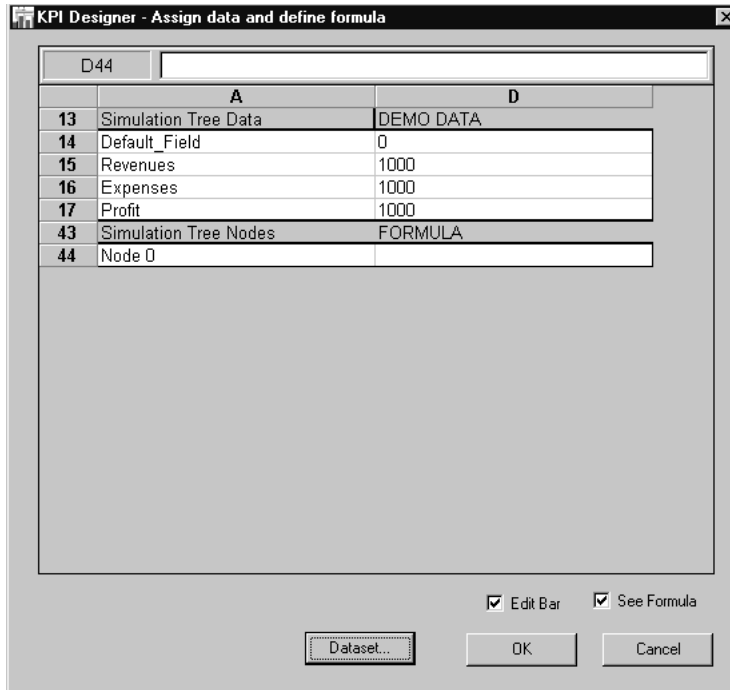

The window is divided into two halves. The top half - called Simulation Tree Data - displays all of the available datasets for this indicator. The bottom half - called Simulation Tree Nodes - displays the Nodes that have been defined on the KPI.

Both the top and bottom parts of the screen are in turn divided into two columns, A and D. For Simulation Tree Data, column A displays the name of the dataset, and column D—also titled "DEMO DATA"—displays the current value of this dataset. If actual data has not yet been loaded into the BSC then this number will be a default, randomly generated number.

For Simulation Tree Nodes, column A displays the Node name, and column D—also titled "FORMULA"—displays the source data for the node. The source for the node can either be a dataset from DEMO DATA, or it can be a formula

based on other node sources. Row 44 under Simulation Tree Nodes is reserved to type the formula of the default node that is going to drive the color. For this definition you need to have previously defined a default node (see "To define the node that determines color calculation:" on page 4-99). After choosing the datasets that you need in the simulation tree, define the formula that is going to drive the default node using any of the datasets previously defined. This calculation will be the basis to determine the color of the simulation tree in the panel. Type the formula as you type formulas in Excel spreadsheets using the symbols +, -, /, etc.

Note: Mark/unmark the Edit Bar checkbox to display or hide the editing bar (the area above the grid in the figure above). Mark/unmark the See Formula checkbox to toggle between displaying formulas or their calculated results. In the figure above, the window is displaying formulas.

2. Click the Dataset button. This will bring up the Simulation Tree Dataset window, shown below.

Figure 4-56 *Simulation Tree Dataset Window*

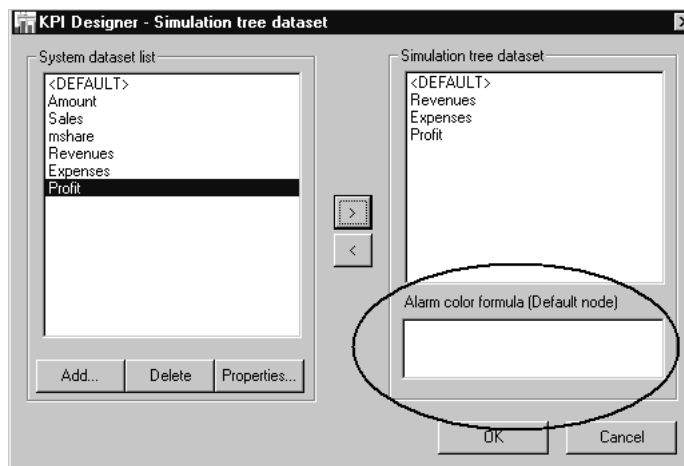

3. The left side of the window shows all the datasets that have been defined in your BSC system. Remember, these are the same datasets as those used for analysis options. The right side shows the datasets available to this Simulation KPI.

4. Highlight any datasets you want to make available to this Simulation KPI and click the right arrow to bring them over to the right side. You cannot make more datasets available for this KPI than the total number of nodes defined on the KPI.
5. If you wish to add datasets, click on the Add button. Provide a name and description for the dataset.
6. To change properties for this KPI, click on the Properties button. This will bring up the standard Edit Dataset Properties window, which was described in "Setting Properties for a Dataset" on page 4-23 of this manual.
7. Click OK to return to the Data Assign and Formula Definition window.
8. Create Source and Formula nodes as needed. The grid area in the window functions exactly like a spreadsheet. To create a Source node, whose source is a dataset:
 - Under Simulation Tree Nodes, select the node you wish to assign a dataset to.
 - Under the FORMULA column for that node, type in "[cell number]", where [cell number] is the Simulation Tree Data DEMO DATA cell for the dataset you wish to assign to this node. In the example below, the node "Revenues" has been assigned the dataset "DollarsRevenues", by making its FORMULA value "=D14", which is the DEMO DATA cell for "DollarsRevenues".

Creating a Formula node, which will be a calculated node, is very similar. Instead of making the FORMULA value for this node equal a Simulation Tree Data DEMO DATA field, you base the value on a formula involving other Simulation Tree Nodes FORMULA fields. In the example above, the Profit node will reflect the calculation of "=D44-D45", which reflects the "Revenues" node minus the "Expenses" node.

Important: When creating items under the Simulation Tree Nodes area of the Data Assign & Formula Definition window, be aware that:

- When defining a dataset in Simulation Tree Data as the source for a Node, the FORMULA column must reference cells in the DEMO DATA column, under the Simulation Tree Data column.
 - If the source for a Node is a formula, the FORMULA column must reference other cells in the FORMULA column under the Simulation Tree Nodes column.
 - Most common Excel spreadsheet formulas can be used under the FORMULA column. You may want to establish the simulation formulas in Excel, and simply copy them here, making sure to change the cell references.
 - All formulas must be referenced to nodes, *not data*.
 - A node whose data set is a formula cannot be simulated.
-
-

Color Triggers in What-if Simulations

Color triggers for nodes define what values cause the colors to change. Values are based on percentage deviancy from actual. For example, at 90% of actual, the color will turn red. Anything above 90% up to 105% is yellow, and anything above 105% should be green.

►► To define color triggers for nodes:

1. From the main Simulation view, right click to activate the pop-up menu. Select Navigation from this menu to enable navigation.
2. Click on the Node you wish to modify color triggers for. This will take you a graphical representation of the node.
3. In the gray area on the right side of the screen, click the right mouse button. This will bring up a pop-up menu.
4. Select Define Color Triggers from this menu.
5. You will now be able to define color triggers for this node. The process is identical to setting color triggers for individual KPIs, as described earlier in this manual
6. To return to the main Simulation window, click on the Simulation button at the bottom of the screen.



►► To define the node that determines color calculation:

1. From within your simulation tree, right-click the node you want to define as the default. From the pop-up menu that appears, select Properties to launch the Edit Node Properties window:

Figure 4–57 Edit Node Properties Window

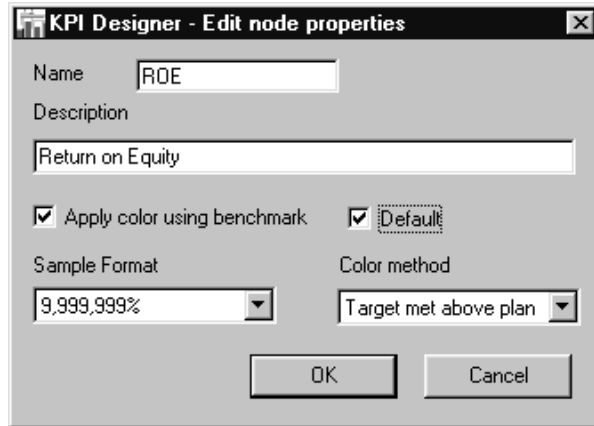

2. In the Name field, enter the name of the node that will drive the color calculation. Check the Default box, then click OK. You have now defined node that determines color calculation.
3. Once you define the default node that will drive the color, go to Data & Formulas and be sure the formula for this node is defined in the Simulation Tree Dataset window (see Figure 4–56).

Special Note About P&L Indicators

While the overall structure of the P&L indicator is fixed, any number of user-defined accounts can be shown in the indicator. The graph consists of floating bars representing user-defined revenue and expenses accounts. Revenue accounts start from the top and are displayed in green bars, while expense accounts start below the last revenue account and are displayed in yellow bars. The bottom-most bar displays the total difference between revenues and expenses.

Figure 4–58 Profit and Loss Indicator

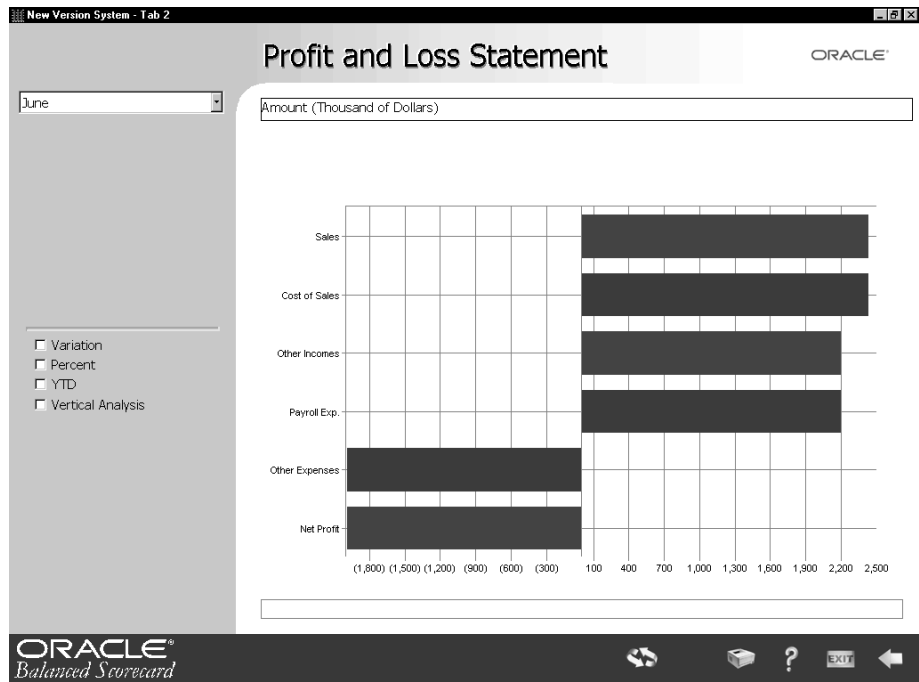

The available calculations include Variation (from target), Parent, YTD, and Vertical Analysis.

Vertical Analysis: This calculation shows the percent contribution of each account to the main account, which is the first, top-most account.

Main account: The user can load any company account whose data > 0 as the first account. If the first account loaded an expense account and its data < 0, the BSC will go to subsequent accounts until it finds the first available one with data > 0. This first positive account becomes the main account for purposes of the Vertical Analysis calculation.

Configuring the P&L indicator is similar to configuring other indicators, except that the P&L indicator is much more limited in the options that can be configured.

To configure the P&L indicator you must have the graph in trend (vertical-bar) mode, focusing on a specific account. To turn the P&L graph into a trend graph click on any of the horizontal bars which represent an account. Any of the account bars will suffice, as it is only necessary to view the indicator as a trend indicator.

The following limitations apply to the P&L indicator:

1. Only one analysis option, and only one analysis option group may exist on a P&L indicator. However, the name of the analysis option may be changed.
2. The following data dimensions cannot be deleted from the P&L indicator, nor can they be modified in any way: Account Type, Account, and Sub-Account.
3. Key Items may not be defined for an indicator which means that the P&L Indicator cannot be configured to default to any specific dimension value, account, or sub-account.

Metadata Optimizer

The internal tables of BSC are dynamic and unique for each and every balanced scorecard because they are created after the user front-end to reflect the data required by that particular system. Once the front-end is completed, data must be fed into the balanced scorecard to actually populate the KPIs. But in order to populate BSC, tables must be created first to store the data. The structure of these tables depends entirely on the data requirements of the balanced scorecard's front-end.

Metadata Optimizer evaluates all the datasets and dimensions specified for a balanced scorecard's KPIs, and then creates an input table structure for populating data to the balanced scorecard. If any datasets have been grouped together using the Dataset Properties feature in KPI Designer, these datasets may be included in the same input table.

The visible user output of the Metadata Optimizer is a set of empty tables that must be populated with data. Metadata Optimizer also creates system tables in the database and configures the BSC Loader to populate these tables from the input tables. This ensures the import structure is optimized for user input. After the user inputs the data into the input tables created by the Metadata Optimizer, the data must be loaded back into the BSC tables using the BSC Loader. See Chapter 6, "BSC Loader" for more detail on using the BSC Loader.

Topics covered in this chapter include:

- ❑ Metadata optimizer and the design process
- ❑ Configuring Metadata Optimizer
- ❑ Running Metadata Optimizer
- ❑ Populating the tables

Metadata Optimizer and the Design Process

Figure 5–1 BSC Design Process

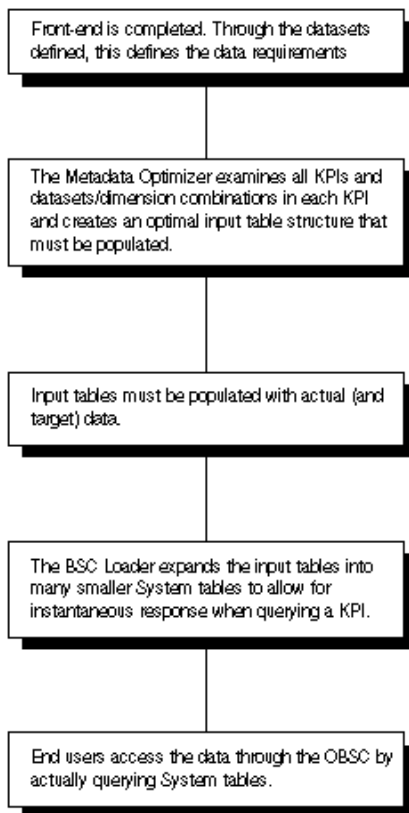

When designing a balanced scorecard, the BSC designer first completes the front-end using the BSC Builder and KPI Designer. Once the datasets are created and properties set using these wizards, the data requirements are defined. Metadata Optimizer then examines all the balanced scorecard's KPIs and creates an input table structure that must be populated. Next input tables must be populated with actual and target data. The BSC Loader expands the input tables into many smaller system tables to allow for instantaneous response when querying a KPI. End users access data through BSC by actually querying the system tables.

Configuring Metadata Optimizer

Setting Configuration Options

The first screen in the Metadata Optimizer is the configure option screen. This screen lets you select the scope of configuration Metadata Optimizer will perform: changed KPIs, all KPIs, or just the dimension tables for all KPIs.

►► To set configuration options:

1. Start Metadata Optimizer. The option screen appears.

Figure 5–2 Metadata Optimizer Configuration Options Window

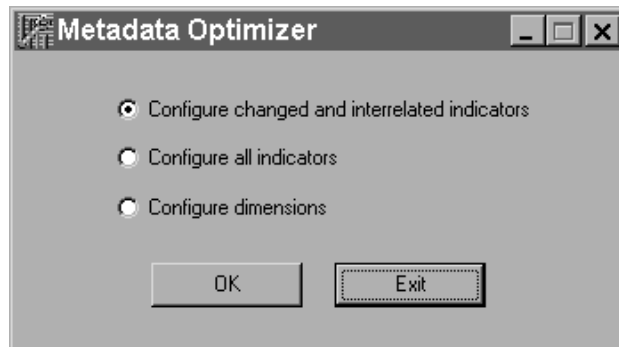

2. Select a configuration option:

Configure changed and interrelated indicators: Builds and configures the input tables only for those KPIs whose structure has changed since the last time the Metadata Optimizer was run. If this is the first time that the Metadata Optimizer is being run, then all KPIs are considered changed, and the first option (to configure changed indicators) is not shown. Using this option, all previously created input tables, historical tables, and systems tables (for the KPIs being configured) will be deleted. However, dimension tables are *never* affected by the Metadata Optimizer.

Configure all indicators: Builds and configures the input tables for all KPIs in the system - changed, and unchanged. All previously created input tables, historical tables, and systems tables for all KPIs will be deleted.

Configure dimension: Configures the dimension tables so they can be edited through the BSC Loader and also creates the relationships between the dimension tables and historical tables. This option is only used during the prototype mode so the dimension drop-down lists on KPIs can be populated with dimension values relevant for client. Running this option does not move the system into the Implementation stage, nor does it remove previously created dimension tables except in the cases where dimension parent-child relationships have changed and the new relationship has to be created. Although not recommended, running this option will also not make any changes to previously created input tables, historical tables and dimension tables. (If changes have been made to KPIs during the implementation phase, we recommend that one of the two above options should be run).

3. Press OK to continue.

Selecting Calculated and Pre-Calculated KPIs

Figure 5–3 Metadata Optimizer KPI Calculation Options Window

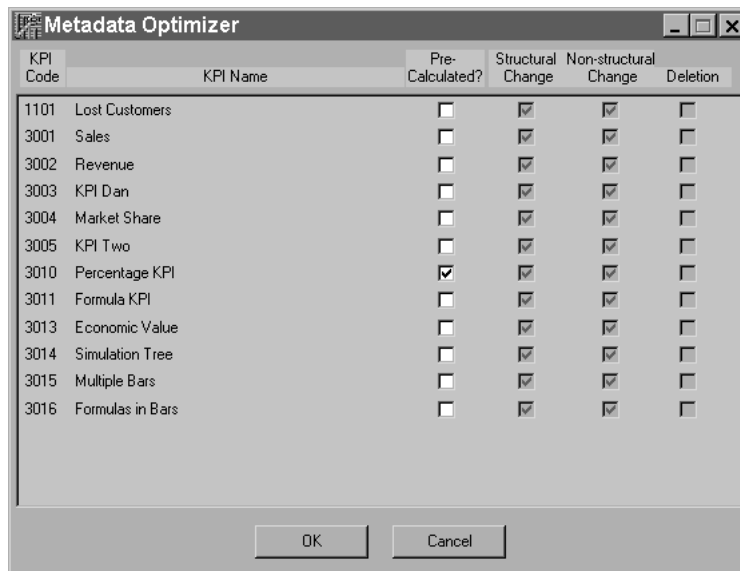

This screen displays what changes, if any, were made to any KPIs, and lets you select which KPIs will come with pre-calculated data from the client.

Note: This screen will only show the KPIs that have changed and will be rebuilt by the Metadata Optimizer. KPIs that do not need to be rebuilt will not be displayed here, even though they may exist in the BSC system.

Taking into account BSC calculation capabilities, a determination should be made beforehand which KPIs the BSC should calculate totals for, and which it should not.

►► **To select KPIs that come with precalculated data:**

1. For each KPI Name listed in the Metadata Optimizer window, check the Pre-Calculated checkbox to allow users to select which KPIs will be provided with pre-calculated summary data. For KPIs that are defined pre-calculated, the Metadata Optimizer will not calculate any totals. Instead, it will provide input tables for all data the KPI will show.

Note: When checked, the Structural Change and Non-Structural Change columns indicate the following about the related KPI:

Structural Change: indicates a structural change to the KPI since the last time the Metadata Optimizer was run. Structural changes include adding and deleting dimensions, datasets, or any other KPI attributes. (For a comprehensive list of structural and non-structural changes, please see Table 7-1, "KPI Structural and Non-structural Changes — KPI Designer" and Table 7-2, "KPI Structural and Non-structural Changes — BSC Builder").

Non-Structural Change: indicates a non-structural change to the KPI since the last time the Metadata Optimizer was run. Non-structural changes usually include color process changes and modifying the default periodicity. (For a comprehensive list of structural and non-structural changes, please see Table 7-1, "KPI Structural and Non-structural Changes — KPI Designer" and Table 7-2, "KPI Structural and Non-structural Changes — BSC Builder").

2. Choose OK to save your changes.

BSC Calculation Capabilities

The BSC system can calculate dimension totals and periodicity roll ups for each KPI. For example, it can perform the calculation of ALL Regions (e.g., West, East, North, South) since data is entered separately for each region. Another type of calculation is the roll up of monthly and quarterly data when the lowest level of data required is daily. In this case, the daily data is entered, but since the users need to also see monthly and quarterly data, daily data is rolled up to monthly and quarterly.

Normal (BSC) Calculated KPIs

Most Key Performance Indicators can be summarized by the BSC Loader. For example, for the Sales Volume KPI, totals can be calculated for both products and states, since dollar amounts can be totaled across all dimensions. In this case, BSC will correctly total each product sum, each state sum, and the overall total. This is called a "Normal Calculated" KPI—one where totals can be correctly calculated.

Table 5–1 Normal Calculated KPIs

State	Product				Sum
	Widgets	Gadgets	Spinners	Throwers	
Georgia	\$10	\$20	\$30	\$40	\$100
Illinois	\$50	\$60	\$70	\$80	\$260
California	\$90	\$15	\$25	\$35	\$165
Texas	\$45	\$55	\$65	\$75	\$240
Sum	\$195	\$150	\$190	\$230	\$765

The Metadata Optimizer evaluates the data requirements for KPIs and optimizes the input tables for that KPI. For example, if a KPI has daily, monthly, and quarterly periodicity, the Metadata Optimizer will only create tables for daily periodicity because BSC can calculate monthly and quarterly data from the daily information. The procedure is similar for summarizing dimensions. If calculations can be run on a KPI then the Metadata Optimizer will only require values for each individual dimension value (e.g., Widgets, Gadgets, Spinners, Throwers). The totals will be calculated automatically.

The BSC can perform KPI transformations where the data can simply be summarized to come up to a total, such as units, amounts, or currency. For KPIs that contain data that can be summarized, *make sure to deselect the "Pre-Calculated?" column.*

Pre-Calculated KPIs

However, with percentage- or ratio-based KPIs, BSC does not calculate sums, because it does not have the source data from which the percentages were originally calculated, and percentages cannot be added to achieve a sum. For example, if we turn the above example into percentages and call it Return Percentage, the following (incorrect) sums will be calculated by BSC.

Table 5–2 *Precalculated KPIs Using Return Percentage*

State	Product				Sum
	Widgets	Gadgets	Spinners	Throwers	
Georgia	10%	20%	30%	40%	100%
Illinois	50%	60%	70%	80%	260%
California	90%	15%	25%	35%	165%
Texas	45%	55%	65%	75%	240%
Sum	195%	150%	190%	230%	765%

The correct totals are shown below. Note that BSC could not calculate them because they result from external data, outside of BSC.

Table 5–3 *Correct Return Percentages*

State	Product				Sum	Correct
	Widgets	Gadgets	Spinners	Throwers		
Georgia	10%	20%	30%	40%	100%	25%
Illinois	50%	60%	70%	80%	260%	65%
California	90%	15%	25%	35%	165%	41%
Texas	45%	55%	65%	75%	240%	60%
Sum	195%	150%	190%	230%	765%	
Correct	49%	38%	48%	58%		48%

For KPIs that contain this type of complex data, *check the "Pre-Calculated?" box*. The Metadata Optimizer will not optimize the input tables for these KPIs, which means that all data for that KPI will have to be entered in the input tables, including the pre-calculated summary data. In this case it is the responsibility of the client, or client systems, to properly sum the data. If the "Pre-Calculated?" box is checked, no

totals or roll ups will be calculated for the KPI by BSC; they must be provided in the Metadata Optimizer input tables.

Running the Metadata Optimizer

After you have selected the proper transformation settings, click the Start button to begin the Metadata Optimizer process. The Metadata Optimizer creates backup tables that contain the historical data for each indicator being configured.

The application starts running and displays a progress window with stages and completion status.

Figure 5–4 Metadata Optimizer Progress Window

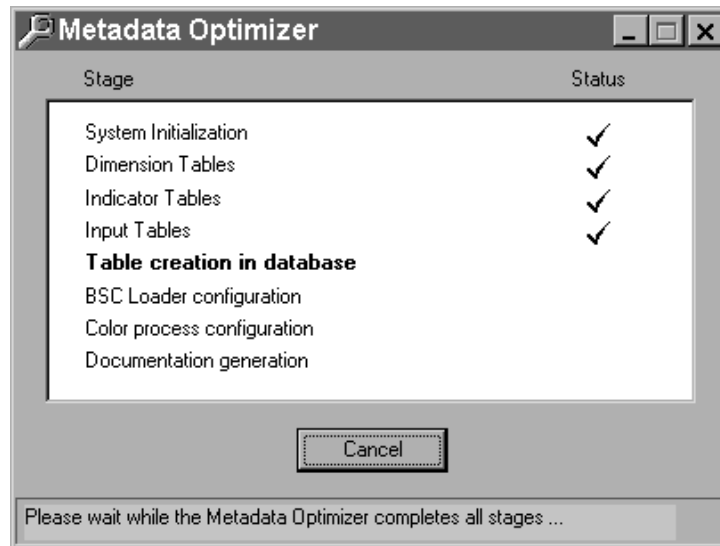

Documenting the Input Tables

When it completes the optimization process, Metadata Optimizer displays a confirmation showing the names and contents of three files it has created:

Figure 5–5 Metadata Optimizer Confirmation Window

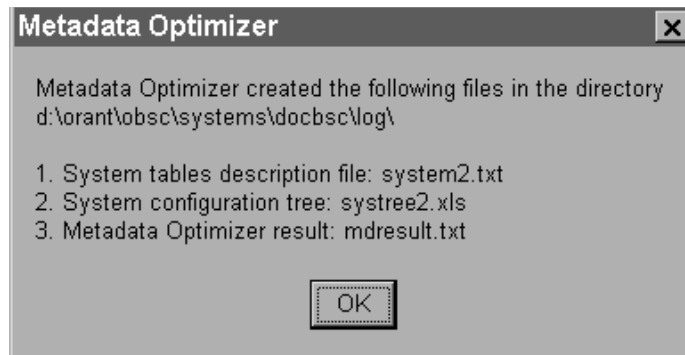

These three files document what tables have been created and which KPIs they refer to. The actual tables are created in the database in the schema "OBSC[System Name]" (where [SystemName] is your actual system name).

system[n].txt¹

This file contains a description of all dimension tables, input tables and system tables generated by Metadata Optimizer for each indicator. Through this report the user can know the structure of all tables which must be populated (especially input tables) without using special SQL commands to query the database.

The first section of the file describes the dimension tables. These tables start with BSC_D and contain the dimension values by which data will be populated in the system. The format for each table description is as follows:

Table 5–4 Dimension Tables Description: BSC_DACCOUNT

TABLE: BSC_DACCOUNT				
FIELD		TYPE	SIZE	DESCRIPTION
CODE		NUMBER		CODE
USER_CODE		VARCHAR2	5	USER CODE
NAME		VARCHAR2	15	NAME

¹ Where [n] is a consecutive number used to avoid overwriting existing files.

Table 5–5 Dimension Tables Description: BSC_D_SUBACCOUNT

BSC_D_SUBACCOUNT				
TABLE:	BSC_D_SUBACCOUNT			
FIELD	TYPE	SIZE	DESCRIPTION	
CODE	NUMBER		CODE	
USER_CODE	VARCHAR2	5	USER CODE	
NAME	VARCHAR2	15	NAME	
ACCOUNT_CODE	NUMBER		See MACCOUNT.COD	
ACCOUNT_CODE_USR	VARCHAR@	5	See MACCOUNT.COD_USR	

Dimension Table Fields

CODE: System code, automatically assigned by the system in the order the records are loaded.

USER_CODE: Alphanumeric user code assigned to each record. For example, East = 1, South = 2, West = A.

NAME: Actual dimension value.

OTHER FIELDS SUCH AS REGION_CODE (shown above): Parents of the dimension and establish what children are associated with what parents. For example: Texas and Alabama with the South region; New Jersey and Maryland with the East region.

The second section of the file describes each of the input tables to be populated with data. The format for these table descriptions is:

Table 5–6 Input Tables Description: BSC_I_1

BSC_I_1				
TABLE:	BSC_I_1			
PERIODICITY:	Monthly			
FIELD	TYPE	SIZE	DESCRIPTION	
SUBACCOUNT_CODE	VARCHAR	25	Usercode (See BSC_D_SUBACCOUNT)	
YEAR	NUMBER	5	Year: 2000, 2001, ...,actual year	
TYPE	NUMBER	3	Type: 0:Real, 1:Plan	
PERIOD	NUMBER	5	Period: 1 to 12	
AMOUNT	NUMBER		Amount	

Table 5–7 Input Tables Description: BSC_1_4

FIELD	TYPE	SIZE	DESCRIPTION
DEPARTMENT_CODE	VARCHAR	25	Usercode (See BSC_D_DEPARTMENT)
EXPEN_TYPE_CODE	VARCHAR	25	Usercode (See BSC_D_EXPENSE_TYPE)
YEAR	NUMBRT	5	Year: 1999, 2000, ..., actual year
TYPE	NUMBER	3	Type: 0:Real, 1:Plan
PERIOD	NUMBER	5	Period: 1 to 12
EXPENSES	NUMBER		Expenses description
HEADCOUNT	NUMBER		Headcount description
SALES	NUMBER		Sales description

These tables are optimized for data entry so if transformations have been selected, only the lowest level of periodicity or dimensions are usually required (the system can calculate rollups).

Input Table Fields

TABLE: the table name

PERIODICITY: What time periods this table includes.

DIMENSION_CODE: this is the value from the USER_CODE field from the respective "D" table. This defines for which dimension value are the values in this record.

YEAR: four digit year

TYPE: 0 = Actual; 1 = Plan (or more specifically, Benchmark #1); 2 = Benchmark #2; etc.

MONTH/PERIOD: the month or period

DAY: day if appropriate

ALL OTHER VALUES BELOW THIS: these are actual values that are described in the last column, as shown in the picture above.

systree[n].xls¹

The systree[n].xls is a Microsoft Excel spreadsheet that diagrams the tables used by each processed KPI and the relationships between tables. If a user needs to know which tables are associated with which indicator (input tables, for instance), he can access a diagram of table relationships for each indicator by clicking on the tab with that indicator's number label. There is a separate tab for each unique KPI in the system. Clicking on a numbered tab brings forward the worksheet for the indicator associated with that number. An example is shown in Figure 5–6.

Figure 5–6 Sample Contents of systree[n].xls File

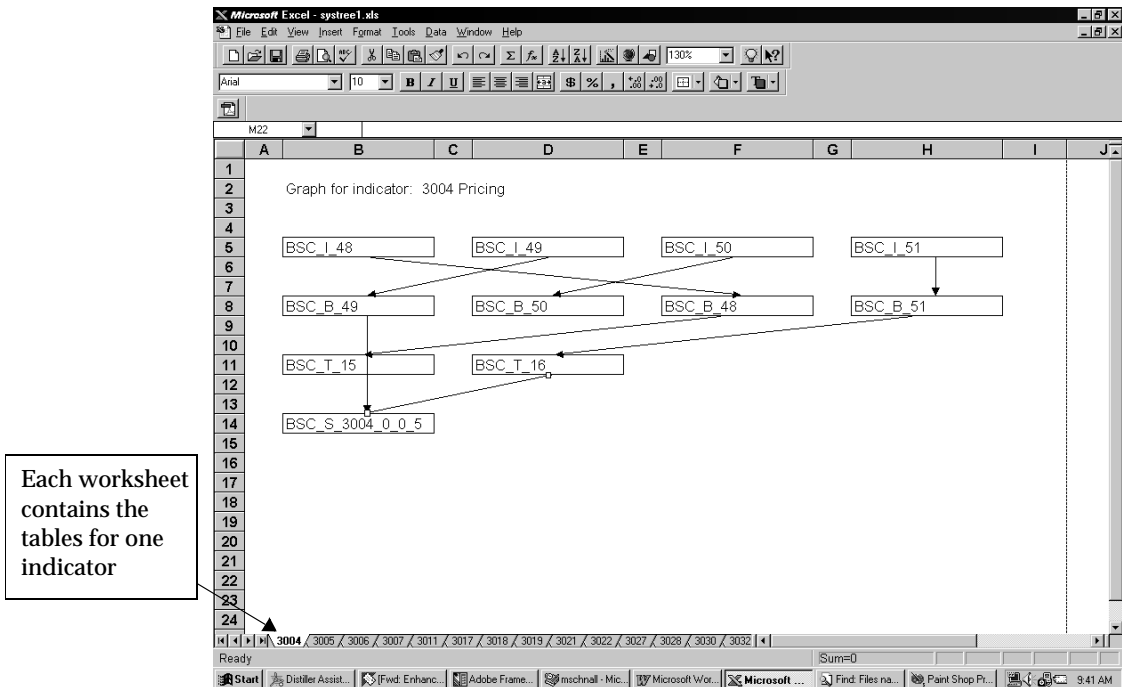

The tables are grouped in rows so the user can quickly identify which tables belong to which function. For instance, all input tables ("I" tables) appear in the top line of systree. These are the only tables that need to be populated by the user. The "B" tables on the second line and the "T" tables on the third line are system tables. The

¹ Where [n] is a consecutive number used to avoid overwriting existing files.

last set of tables, the "S" tables are also system tables, but these are the tables being directly read by the Viewer.

The "I" tables must be populated by the client using the directions in the system.txt file. The "B", "T", and "S" tables are populated automatically by the system using BSC Loader.

mdresult[n].txt¹

Each time you run Metadata Optimizer, the mdresult.txt file is updated with a summary of that optimizer run. This report presents the changes made to the processed indicators. It also present the name of the backup tables built for the base tables used in the system before running the Optimizer.

Example 5-1 Sample contents of mdresult.txt file

```

+-----+
+
Oracle Balanced Scorecard: Version : 11i.6

Copyright (c) Oracle Corporation 2001. All rights reserved.

Module: Metadata Optimizer
+-----+
+

Time: February 24, 2000 12:42:12

Metadata Optimizer result:
-----

3001 Loans Portfolio - Ind
Structural change(s): Add or drop a dimension, data set, analysis group, etc.
Input table(s)
-----
BSC_I_47 (Monthly)
    PROCESS_CODE
    YEAR
    TYPE
    PERIOD
    RISKINDEX
BSC_I_48 (Monthly)

```

¹ Where [n] is a consecutive number used to avoid overwriting existing files.

```

        PROCESS_CODE
        YEAR
        TYPE
        PERIOD
        T23456789012345678
        NAMELONGERTHAN20CHAR
        SALESPERIOD
        CPPRR
        SALESPROM
BSC_I_49 (Monthly)
        PROCESS_CODE
        YEAR
        TYPE
        PERIOD
        FININCOMES
        FINMARGIN
BSC_I_50 (Monthly)
        PROCESS_CODE
        YEAR
        TYPE
        PERIOD
        CREDITS
Old input table(s)
-----
BSC_I_47

BSC_I_48

BSC_I_49

Backup table(s)
-----
BSC_B_47_BAK (Monthly)
        PROCESS_CODE
        YEAR
        TYPE
        PERIOD
        RISKINDEX
BSC_B_48_BAK (Monthly)
        PROCESS_CODE
        YEAR
        TYPE
        PERIOD
        T23456789012345678
        NAMELONGERTHAN20CHAR
        SALESPERIOD
        CPPRR
        SALESPROM
BSC_B_49_BAK (Monthly)
        PROCESS_CODE
        YEAR
        TYPE
        PERIOD

```

BSC_I_50	FININCOMES FINMARGIN BSC_B_50_BAK (Monthly) PROCESS_CODE YEAR TYPE PERIOD CREDITS
3003 MEM01 New indicator.	
3007 Market share - Ind No changes were made.	

Populating the Tables

Once you have the output files from Metadata Optimizer, you are ready to populate your tables with data. To populate data into the system, use BSC Loader. To learn more about using BSC Loader, refer to Chapter 6, "BSC Loader". For specific instructions on populating the system, see Chapter 7, "Populating and Deploying BSC".

Table 5–8 Internal BSC Tables

Input Tables	"I" Tables - start with BSC_I in the database.	"I" tables are input tables that must be populated by the client with actual data. These tables are created by the Metadata Architect based on data requirements as defined on the Viewer using the KPI Designer. These tables are loaded into BSC System tables using the BSC Loader
Dimension Tables	"D" Tables - start with BSC_D in database	"D" tables contain dimension values. For example, the values for the Region dimensions could be West, South, North, and East. Normally there is one D table per dimension.

Table 5–8 Internal BSC Tables

System Tables	"S" Tables - start with BSC_S in the database	System tables are populated by the BSC Loader by calculating and de-normalizing the Input tables. These detailed tables contain the calculated data that the Viewer reads when displaying a graph.
Historical Tables	"B" Tables - start with BSC_B in the database	These tables contain historical KPI data. Any data loaded in BSC is also loaded in "B" tables and kept there indefinitely for use by the system. "B" tables are only emptied manually by the user, or when the Metadata Architect rebuilds the KPI.
Temporary Tables	"T" Tables - start with BSC_T in the database	These are temporary tables for data storage and calculations.

Note: Remember that when you are populating data in your input tables, your data type is always TYPE: 0 for Actual data; Type 1 for Plan or benchmark coded as 1; Type 2 for benchmark coded as #2; Type 3 for benchmark coded as #3, and so on.

General

In general, you should not run Metadata Optimizer at the same time with any other OBSC application such as OBSC Architect, Setup or Manager.

BSC Loader

Use BSC Loader to pull data from your populated input tables into the BSC tables used by the Viewer. BSC Loader takes the data that have been entered into the input tables and derives multiple system-level tables, called “system tables,” that are used to display KPI data in the Viewer.

Each analysis option reads its own unique system table. Oracle Balanced Scorecard can instantly respond to changes in KPI graphs because the graphs’ data points are pre-calculated and stored within system tables. In this way, BSC combines features of a relational database (flexibility and query strength) with those of an OLAP-type data cube (instantaneous, pre-calculated results).

In this chapter you’ll learn to:

- Load and maintain dimensions
- Load BSC tables
- Change the current year
- Delete data

Loading and Maintaining Dimensions

Dimension values are the drill-down categories into which KPI data are classified. For example, the dimension Region might include the values East, West, South and North. Maintaining dimensions will often - but not always - be the first step in loading BSC.

Load Dimension Values Before the Input Tables

If this is the first time the system is populated with actual data, the proper dimension values need to be loaded in the dimension tables. Due to data value dependencies, dimension values must be loaded into BSC before they are used by input tables. This is because input tables always contain a dimension code to reference the proper dimension value, and that dimension code has to be loaded in the system first, using dimension tables.

Maintaining Dimension Tables

Once populated in the system, dimension values are usually relatively static, and maintaining dimensions becomes a secondary process. For example, the Region dimension may incorporate a company's four corporate regions (East, West, South and North) as dimension values. Unless a corporate restructuring takes place, these regions (i.e., dimension values) are not likely to change often. So while values like these need to be populated once, they may not be affected in the subsequent maintenance of BSC data, and therefore will not need updating.

Updating Dimension Values in Dimension Tables

Dimension tables are the "D" tables in the database. You can populate these tables through the "Maintain Dimension" tab in the BSC Loader.

Note: Loader is case sensitive for the values in master tables. This means when populating data into tables you have to be careful with the names given to your master table values since they are case sensitive.

►► To view and update dimension values:

1. In the BSC Loader main window, click the Maintain Dimensions tab to bring it forward. The Maintain Dimensions tab displays all the "D" tables in the database.
2. Highlight a dimension table to select it and click Edit. An editing window appears that lets you edit dimension values.
3. Click Edit to edit the values directly on the window or click Import to import from a text file. The Import screen appears.

4. If you choose to import, use the Browse button to locate the file you wish to import. The file has to be a text file delimited with semicolons (;). See the following example for the BSC_DSTATE table.

Table 6–1 BSC_DSTATE Table Description

CODE	NUMBER	22(5)	Code
USER_CODE	VARCHAR2	5	Usercode
NAME	VARCHAR2	30	Name
REL_REG	NUMBER	22(5)	See BSC_D_REGION.CODE
REL_REG_USR	VARCHAR2	5	See BSC_D_REGION.USER_CODE

The file to import would look like this:

```
S1;California;1
S2;Florida;2
S3;Texas;2
```

The text file to import must ONLY CONTAIN THE “NAME” FIELD AND ANY FIELDS THAT END IN “_USR”, IN THE ORDER LISTED IN THE SYSTEM.TXT FILE. For example only the following field values need to be listed in the import file above:

USER_CODE, NAME1, and REL_REG_USR

5. Any invalid fields appear in the Invalid Fields area. If there are invalid fields, make the required corrections and reload the data. Examples of invalid fields include:
 - A line in the text file that doesn't contain the correct number of fields
 - A line that contains a null or duplicated key value
 - A line that contains fields with the wrong type or length
6. Click the Invalid Fields button to toggle to the Invalid Relationships display. If there are invalid relationships then make the required corrections and reload the data. An example of an invalid relationship is: Loading a line where a relationship field value is null or doesn't exist in the parent table.

Loading BSC Tables

After your dimension values have been loaded in the “D” tables, the next step is to define the data source for each “I” table. Use the Load BSC Tables tab to load the input data in the “I” tables into the system tables. The systree.xls file tells you which tables are for which KPIs.

Note that “I” tables can either be populated in the Oracle database or exist as spreadsheet or text files. BSC Loader will load any of these three formats into the system tables. However, before loading can occur, you must input:

- A format for each “I” table
- A location for each “I” table source

Define Data Source

The Define Data Source button lets you select different data sources for the “I” tables. These “I” tables are then used to load the BSC system tables for the Viewer.

►► To load the BSC input tables:

1. Click the Load BSC Tables tab to bring it forward.

Figure 6–1 Load Tables Window

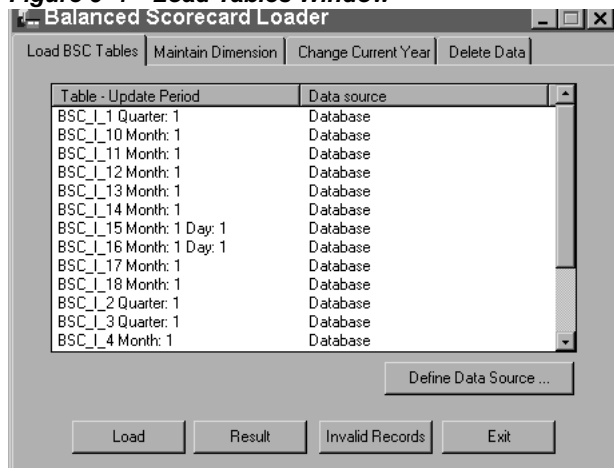

2. Define the data source for an input table by selecting the table in the Table-Update Period table and clicking the Define Data Source button. The Define Data Source window appears.

Figure 6–2 Define Data Source Window

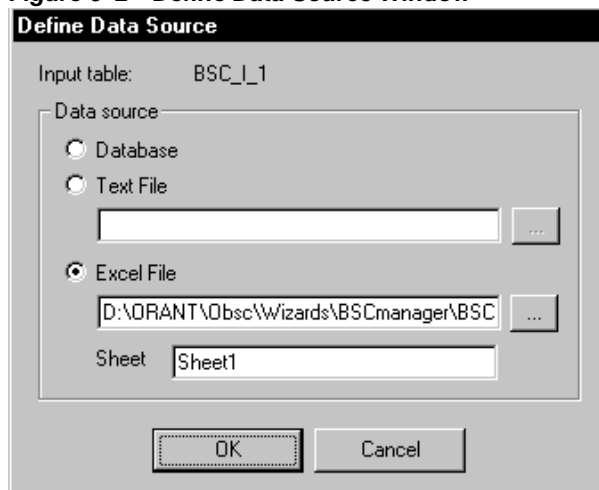

3. Select a radio button to identify the data source:
 - **Database:** If the data has been placed directly in the database “I” table (in this case BSC_I_11). This is the default.
 - **Text File:** If the data resides in a text file on your system. The text file must be a semicolon (;) delimited file.
 - **Excel File:** if the data is in an Excel spreadsheet. You will also have to provide the specific Sheet (tab) name. If you choose this option, make sure your Excel spreadsheet doesn’t contain any headers.
4. Click OK to save your changes, or Cancel to cancel.
5. Highlight or select the tables in the BSC Load Tables tab and click Load. This will load the data in the selected input tables into the related system tables.
6. Invalid Records brings up a dialogue screen that shows invalid records. There are three cases where you may receive invalid records:
 - A record in the input table where the user code for a dimension is not registered in the dimension “D” table. Example: The input table has a record for the region “R3” and “R3” is not in the field USER_CODE of BSC_D_REGION

- A monthly table where the PERIOD field value is <1 or >12.
 - A record that is outside the year range of the system. For example, if BSC is set up to handle a range of 10 years, of which 5 can be previous, in 1999 it only accepts input data for years 1994 to 2003. And invalid record would be for any year outside of this 10 year range, for example 1992.
7. After the Loading process has been run, the data that was placed in the “I” tables is deleted. Those tables have to be repopulated before running the Loading process *again*.

Submitting the Process to the Oracle Applications Concurrent Manager

Once you have selected the tables you want to load, you will receive a message to submit a request to run the Loader at a specific time for which you want to schedule the process.

The request is received as a pending process that you can run at the scheduled time in the Oracle Applications environment. See Appendix B, "Scheduling Concurrent Requests" and consult the *Oracle Applications System Administrator's Guide*.

Note About Populating Pre-Calculated KPIs Tables

There is only one difference between populating Input "I" tables for simple KPIs and populating them for Pre-Calculated KPIs. For Pre-Calculated KPIs, the totals must be loaded in the Input table. This is achieved in the form of a "code zero" record for each total. For example, a normal KPI input table may look like this:

Table 6–2 KPI Input Table Example

STATE_CODE	YEAR	TYPE	PERIOD	SALES_VOLUME
1	1999	0	1	100
1	1999	0	2	150
1	1999	0	3	125
2	1999	0	1	200
2	1999	0	2	175
2	1999	0	3	180

Each state code above, references one of the state codes defined in the dimension table (shown below):

Table 6–3 Dimension Table Example

CODE	USER_CODE	NAME
1	1	Georgia
2	2	Illinois
3	3	California
4	4	Texas

So for example, the first line of the input table shows that state code 1 (Georgia) had a sales volume of 100 units in their first fiscal month (June, for example). Other rows represent similar data.

However, for a Pre-Calculated KPI, the totals have to be added to the table in form of a 0 code for every item (in this case, States), for the periods included in the table. For example, notice the additional rows that have to be added to the same input table for the same KPI (these represent the total for all states by period):

Table 6–4 Pre-Calculated KPI example

STATE_CODE	YEAR	TYPE	PERIOD	SALES_VOLUME
0	1999	0	1	300
0	1999	0	2	325
0	1999	0	3	305
1	1999	0	1	100
1	1999	0	2	150
1	1999	0	3	125
2	1999	0	1	200
2	1999	0	2	175
2	1999	0	3	180

Note: The file system.txt shows which columns of input tables require null codes.

The first row shows the total for all states for period 1: the 0 code is in the STATE_CODE column. The second row has the total period 2, and the third row shows the total for period 3. Notice that a 0 (zero) code in the item field (in this case, State) represents a total.

One important item to note is that *for parent-child dimension, such as State and City (where State is the parent of City), only the parent table needs to have the 0 code.* This is because the sum of the parent is automatically the sum of the child. For example, the total Georgia sales volume by month, includes the totals for all Georgia cities (Atlanta, Columbus, Savannah, and Macon) by month.

So in the City table, you would not have to provide the 0 code (or sum) for all cities. For example, you would not have to enter the first three lines in the example below:

Table 6-5 City Table Example

STATE_CODE	YEAR	TYPE	PERIOD	SALES_VOLUME
0	1999	0	1	300
0	1999	0	2	325
0	1999	0	3	305
1	1999	0	1	100
1	1999	0	2	150
1	1999	0	3	125
2	1999	0	1	200
2	1999	0	2	175
2	1999	0	3	180

These lines represent the total for all cities (by month), but this total can already be found in the State table, since there is a parent-child relationship between states and cities. The State table will contain the 0 code representing totals.

Change Current Year

This feature lets you update the current year. The person who originally designed a balanced scorecard in KPI Designer sets the fiscal year and month.

►►To update the fiscal year:

1. Select the Change Fiscal Year tab to bring it forward and click OK. The following message appears:

“The year change process will update all the indicators to the new year. The current year will become the previous year and it’s plan data will be erased. Continue?”

2. Click Yes to update the fiscal year.
3. Once the current year has been updated, you need to load the target or benchmark data for the current year.

Delete Data

This feature deletes all data from all the tables for the selected indicator, and resets the last updated period for the indicator as the 1st month of the fiscal year.

Note: BSC Administrators can load in pre-calculated custom forecast data into their KPI if the KPI was defined as such in the KPI Designer. For custom forecasts, data is loaded in the KPI’s respective input table with Type=90 to identify the data as custom forecast data. The rest of the fields are identical to loading in actual data.

General

In the Oracle Applications environment, you need the concurrent manager to run the Loader. For more details, see Appendix B, "Scheduling Concurrent Requests".

Populating and Deploying BSC

To populate and deploy BSC, you will need to follow specific steps. These steps can be grouped in three stages:

- ❑ **Setup Stage:** The stage when you create the system using the BSC Builder and KPI Designer wizards. During this stage, the Viewer displays random data. When the Metadata Optimizer is run for the first time, it will build input tables and other system tables for all the KPIs in the system.
- ❑ **Implementation Stage:** The implementation stage begins once the Metadata Optimizer process has run for the first time on the KPIs (not just the dimension tables, which is an option in the Wizard). At this point, the Viewer will no longer show random data. To see graphs and colors in the Viewer, you must populate actual test data in the input tables and load it into the system using the BSC Loader. Implementation is a "prototype" or "testing" phase that precedes deployment of a production system.
- ❑ **Production Stage:** Production stage begins once you have populated the system. The system now contains production data and is accessed by one or more users.

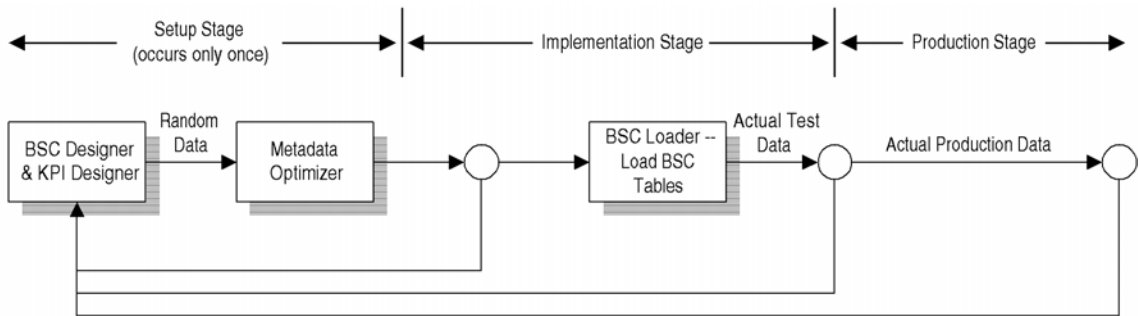
Figure 7-1 Stages of the BSC Design Process

Important: Each KPI can have its own stage and be in a different stage from other KPIs. For example, on the same BSC system, one KPI can be in the Production stage, populated with actual data, while another can remain in the Implementation (testing) stage. (The BSC system in this case will not provide random alarm colors for the implementation KPI).

Loading Actual Data in BSC

Loading data into BSC involves both Metadata Optimizer and BSC Loader. The Metadata Optimizer is run to determine the system's input table structure, which is based on the data requirements of the Viewer. Once input table structures are created by the Metadata Optimizer they must be populated by the client; this step is external to the capabilities of BSC. After the input tables have been properly populated, the BSC Loader must be run to load the input table data into the BSC system tables.

Creating an Implementation System (Using Actual *Test* Data)

►► To create an implementation system

1. After the structure has been finalized and frozen using the BSC Architect, run the Metadata Optimizer for the first time.
2. Populate the input tables for one or more KPIs with actual test data.

3. Run the BSC Loader to load the input table data into the BSC system tables.
4. Result is an Implementation system with one or more KPIs populated with actual test data.

Updating KPIs in Implementation Stage

Use the BSC Builder and KPI Designer wizards to update KPIs.

►►To update KPIs during the Implementation stage:

1. Run the Metadata Optimizer to create a new set of input tables (and dimension tables, if necessary) for the modified KPIs and any related KPIs. The Metadata Optimizer can be run using one of three options:
 - Reconfigure input tables for only the updated subset of KPIs
 - Reconfigure input tables for all KPIs
 - Reconfigure dimension tables only

Notes:

- The Metadata Optimizer will empty all input and system tables related to KPIs that are configured using the first two options. "Configure dimension tables" creates only the system dimension tables and allows users to populate them using the BSC Loader.
 - When configuring the input tables for only changed KPIs, depending on dataset and dimension interdependence between KPIs, the Metadata Optimizer may also empty the tables of KPIs that share a common dataset or dimension with a changed KPI, even though that KPI was not directly changed. The application will list all the related KPIs, if any, that will be affected by the changes in a KPI.
 - The input and system tables must be emptied, and the data reloaded by the client, because structural modifications to KPIs may require a different input table structure.
-
-
2. The Metadata Optimizer will make a backup of the historical data tables - also known as "B", or Base tables - for any KPIs where it has to rebuild the input tables. From this backup you may recreate the input data required to repopulate the KPI with historical data.
 3. Populate the recreated KPI input tables and rerun the BSC Loader to load data back into the BSC system tables.

Note: The process of modifying KPIs, creating input tables, populating input tables, and running the BSC Loader can occur an indefinite amount of times.

Modifying KPIs in Production Stage (Using Actual Production Data)

If the BSC system is currently being used by one or more users but changes need to be made to the system (adding, deleting, or modifying KPIs or groups, or changing the layout), we strongly recommend that you create a backup of your database using Oracle Applications backup utilities.

Notes:

- No changes should be made to the production database until a backup of the database is created.
 - Some non-structural changes do not require administrators to make a backup of the database. For example, changes such as color methods can be made directly in the production system itself. See the complete list of structural and non-structural changes in the table below.
-
-

Table 7–1 KPI Structural and Non-structural Changes — KPI Designer

KPI Designer Action	Affected KPI(s)	Change Type	Reason
Add Analysis Group	Changed KPI only	Structural Change	Changed table columns
Add Analysis Option	Changed KPI only	Structural Change	Changed table columns
Add or Delete Dimension in a Dimension Group	All KPIs using the dimension Group	Structural Change	Changed table columns
Add Series in Dataset	All who use this Dataset	Structural Change	Changed the names of the data Columns
Affect Dataset selection in adding or deleting the Simulation Tree Node	Changed KPI only	Structural Change	Changed table columns
Assign a Dataset	Changed KPI only	Structural Change	Changed table columns
Assign Source group in Dataset	All who use this Source group	Structural Change	Changed the way to make a group of fields in the input tables structure

Table 7-1 KPI Structural and Non-structural Changes — KPI Designer

KPI Designer Action	Affected KPI(s)	Change Type	Reason
Assign Source in Dataset	All who use this Dataset	Structural Change	Changed the column structure
Change Dataset for the Simulation Tree Node	Changed KPI only	Structural Change	Changed table columns
Change Dimension Relationship	All KPIs using the dimension	Structural Change	Changed table columns
Define Periodicity	Changed KPI only	Structural Change	Changed table columns
Delete a Dataset	All who use this Dataset	Structural Change	Changed the names of the data Columns
Delete Analysis Group	Changed KPI only	Structural Change	Changed table columns
Delete Analysis Option	Changed KPI only	Structural Change	Changed table columns
Delete Dimension	All KPIs using the dimension	Structural Change	Changed table columns
Delete Dimension Group	All KPIs using the dimension Group	Structural Change	Changed table columns
Delete Dimension Set in Assign Dimension Option	Changed KPI only	Structural Change	Changed table columns
Delete Series in Dataset	All who use this Dataset	Structural Change	Changed the names of the data Columns
Edit Data Properties – Define formula including a new source – in Dataset	All who use this Dataset	Structural Change	Changed the column structure
Edit Dimension Properties – Change the dimension table Key	All KPIs using the dimension	Structural Change	Changed table columns
Edit Dimension Properties – Change the dimension table name	All KPIs using the dimension	Structural Change	Changed table columns
Edit Dimension Properties inside of a Dimension Set –Add a Dimension Group – in Assign Dimension Option	Changed KPI only	Structural Change	Changed table columns

Table 7–1 KPI Structural and Non-structural Changes — KPI Designer

KPI Designer Action	Affected KPI(s)	Change Type	Reason
Edit Dimension Properties inside of a Dimension Set –Delete a Dimension Group – in Assign Dimension Option	Changed KPI only	Structural Change	Changed table columns
Edit Source Properties – Change Name – in Dataset	All who use this Source	Structural Change	Changed the field name
Add the Budget Benchmark	Changed KPI only	Non-structural: Color Process Configuration	Changed the color process configuration
Change the formulas for the Simulation Tree Node which will affect the result node	Changed KPI only	Non-structural: Color Process Configuration	Changed the color process configuration
Define Color Triggers	Changed KPI only	Non-structural: Color Process Configuration	Changed the color process configuration
Edit Data Properties – Change Color Method – in Dataset	All who use this Dataset	Non-structural: Color Process Configuration	Changed the indicator default screen
Edit Data Properties – Define formula not including a new source, but change the analysis option default – in Dataset	All who use this Dataset	Non-structural: Color Process Configuration	Changed the indicator color
Edit Dimension Properties –Initialize Option – inside of a Dimension Group	All KPIs using the dimension Group	Non-structural: Color Process Configuration	Changed the indicator default screen
Edit Series Properties – Change Color Default – in Dataset	All who use this Dataset	Non-structural: Color Process Configuration	Changed the indicator default screen
Edit Simulation Node Properties – Change Color for the Simulation Tree Node other than default color	Changed KPI only	Non-structural: Color Process Configuration	Changed the color process configuration
Modify Default Periodicity	Changed KPI only	Non-structural: Color Process Configuration	Changed the color process configuration

Table 7-1 KPI Structural and Non-structural Changes — KPI Designer

KPI Designer Action	Affected KPI(s)	Change Type	Reason
Remove the Budget Benchmark	Changed KPI only	Non-structural: Color Process Configuration	Changed the color process configuration
Change the year, previous year in Periodicity Option	Changed KPI only	Non-structural: BSC Loader Configuration.	Changed the projection
Edit Source Properties – Change roll up – in Dataset	All who use this Source	Non-structural: BSC Loader Configuration	Changed the way to calculate the totals

Table 7-2 KPI Structural and Non-structural Changes — BSC Builder

BSC Builder Action	Affected KPI(s)	Change Type	Reason
Add new KPI	New KPI	Structural Change	Changed table columns
Copy KPI	Copied KPI	Structural Change	Changed table columns
Create a template	All KPIs	Structural Change	New template
Delete KPI	Deleted KPI	Structural Change	Changed table columns
Drag and Drop KPI	New KPI	Structural Change	Changed table columns
Select KPI on a tab	Selected KPI	Non-structural: Color Process Configuration	Changed the color process configuration
Select or deselect List button	All indicators on tab	Non-structural: Color Process Configuration	Changed the color process configuration
Select or unsettle List button dimension	All indicators on tab	Non-structural: Color Process Configuration	Changed the color process configuration
Edit KPI	Changed KPI	Documentation fields	Changed name, description

BSC Administrator

Through the BSC Administrator, you can control and change access privileges and filter information by responsibility (task or job scope). You can also use Administrator to define email information by user.

In this chapter you'll learn to:

- ❑ Grant and restrict access to scorecards
- ❑ Assign data filters using global list values
- ❑ Design security levels by user responsibility, tab and KPI
- ❑ Define user information

Overview of Administrator

Security in BSC is based on the responsibility concept. Responsibilities and users are defined through Oracle Applications forms and can only be accessed in Balanced Scorecard if you are connected to an Oracle Enterprise database.

There are two seeded responsibilities in BSC:

- **Balanced Scorecard Manager:** This responsibility allows users to sign on to BSC through Self-Service Web Applications. All BSC Release 11i.6 users must be assigned the Balanced Scorecard Manager responsibility in addition to any other responsibilities the user may have.
- **Balanced Scorecard Supervisor:** This is the responsibility assigned to the BSC administrator.

Use the Administrator to maintain and control access to balanced scorecards by responsibility or to define user information. Defining security for your system

should be the last step before full deployment of the Balanced Scorecard your end-users.

Before Administrator's functionality can be accessed you must:

- Run Setup, BSC Builder and KPI Designer to create and configure your system.
- Run Metadata Optimizer to build input and other system tables (see Chapter 5, "Metadata Optimizer").
- Define users and responsibilities through Oracle Applications (for more information, see *Oracle Applications User's Guide* and Appendix A, "Oracle Applications Security").

Defining Responsibilities

Before assigning security privileges, you must first define responsibilities, or spans of control. Generally a responsibility equates to a job title, such as CEO, CFO or Product Manager. This is done in the Oracle Applications environment (for more information, see Appendix A, "Oracle Applications Security" and the *Oracle Applications User's Guide*).

Since all security in BSC is based on responsibility, choose these with care. It is advisable to choose descriptive titles that exhaust all the main responsibility categories in your organization. Once responsibilities are defined, they are used as the basis for assigning security privileges by tab, list value and KPI.

Tab security and indicator security are based on responsibilities and users previously defined in Oracle Applications. This functionality is only available if you are connected to an Enterprise database.

Providing Tab (Scorecard) Access

You can use BSC Administrator to grant or restrict access to specific Balanced Scorecard tabs. Tabs are individual scorecards which have been customized for specific organizational roles. Each tab has its own indicators and layout and is actually a separate balanced scorecard. Note that while each system contains many scorecards/tabs, each tab is not a separate system.

An organization's balanced scorecard may include any number of individual tabs. You can give users access to specific tabs based on job responsibilities. In addition, users may be given the option to filter data that appears on their personal scorecards by KPIs.

For example, assume that a corporate BSC was defined with six tabs. Five of the tabs contain scorecards for each of five functional areas. The first tab is a corporate-wide balanced scorecard. The five functional areas are finance, marketing, operations, sales, and quality.

Using the tab assignments feature in the Administrator, user access can be restricted so that the Vice President of Marketing only sees the Marketing tab when he logs in, while the Vice President of Sales only sees the Sales tab when she logs in. This essentially gives each user a personal balanced scorecard. The CEO, or any other executive, could have access to the corporate-wide tab plus all or some of the five functional tabs, as appropriate.

Global List Values

In addition to providing tab- and indicator-level security, BSC Administrator is also used to provide users with filtering capability for both dimensions and dimension values using the List button (for more information on using the List button, see Chapter 3, "BSC Builder").

Dimension Value Filtering (Global List Values)

Using the List feature, users can filter a balanced scorecard by any dimension value in a given dimension. If a dimension is shared by all the KPIs on a tab, that dimension can be used as a data filter for the scorecard.

For example, if Region is a common dimension across all the KPIs on a tab, and the dimensions are configured in the same position, the Region dimension can be placed on the main panel of the tab. Users with access to the tab can view the alarm colors for each distinct Region (East, West, South, North) and any other region values that may exist.

Dimension Value Security (Item Values)

Dimension value security restricts users to viewing a single dimension value in a scorecard. For example, if there are several sales managers, each with responsibility over one region, you can use BSC Administrator to restrict the sales manager for the West region to only see data for that region (i.e., the West region tab and only a specific value on that tab, such as District A), and the North region sales manager to only see information about the North region. If this restriction is enabled, the alarm colors the user sees on the main panel will be calculated only for the dimensions to which he/she has access. Users can only see dimensions to which they have been granted access.

To activate dimension-level security, the List feature must be enabled in the system. This feature involves several restrictions (for more information, see Chapter 3, "BSC Builder", section titled "Using the List Button").

KPI Security

Finally, for each responsibility, you can control not only the tabs but the KPIs accessible to that responsibility and tab. Using the Indicator Security tab, you can control what each user sees on each tab to which he has access. In the case of a Product Line Manager, the Quality Assurance KPI might have less relevance than the Sales Growth KPI. For other responsibilities such as CFO, Sales Growth might be more relevant. Use BSC Administrator's Indicator Security features to tailor each tab to a manager's responsibility scope.

Using the Administrator

When you launch the Administrator, you see three tabs:

- **User Information:** This screen shows each user ID and its associated email privileges. Each user may have more than one responsibility title.
- **Tab Security:** Use this tab to grant or restrict access to scorecards by responsibility and to set global list values and item values.
- **Indicator Security:** Use this tab to manage access to particular KPIs within scorecards by responsibility.

User Information

When you first open Administrator, the User Information tab appears. Certain information on this screen (such as user names and email addresses) is predefined in Oracle Applications Forms and cannot be modified through BSC until first defined through Oracle Applications Forms (for more information, see *Oracle Applications User's Guide*).

Figure 8–1 User Information Security Window

The screenshot shows a window titled "Oracle Balanced Scorecard Administrator" with three tabs: "User Information", "Tab Security", and "Indicator Security". The "User Information" tab is active. The window contains a "Users" section with the following fields:

Full Name	<input type="text" value="John Smith"/>	Email Address	<input type="text" value="jsmith@abc.xyz.com"/>
User Name	<input type="text" value="SYSADMIN"/>	Email Password	<input type="password" value="*****"/>
		Email Host	<input type="text" value="imap01.abc.xyz.com"/>
		Email Protocol	<input type="text" value="imap"/>
		SMTP Host	<input type="text" value="smtp01.abc.xyz.com"/>

Below the fields is a checkbox labeled "Auto-connect at Logon" which is currently unchecked. At the bottom right of the window are three buttons: "OK", "Cancel", and "Exit".

Tab Security

Use Tab Security to:

- Administer tab (scorecard) access by responsibility
- Assign global list values
- Assign item values

Click the Tab Security tab to bring it forward:

Figure 8–2 Tab Security Window

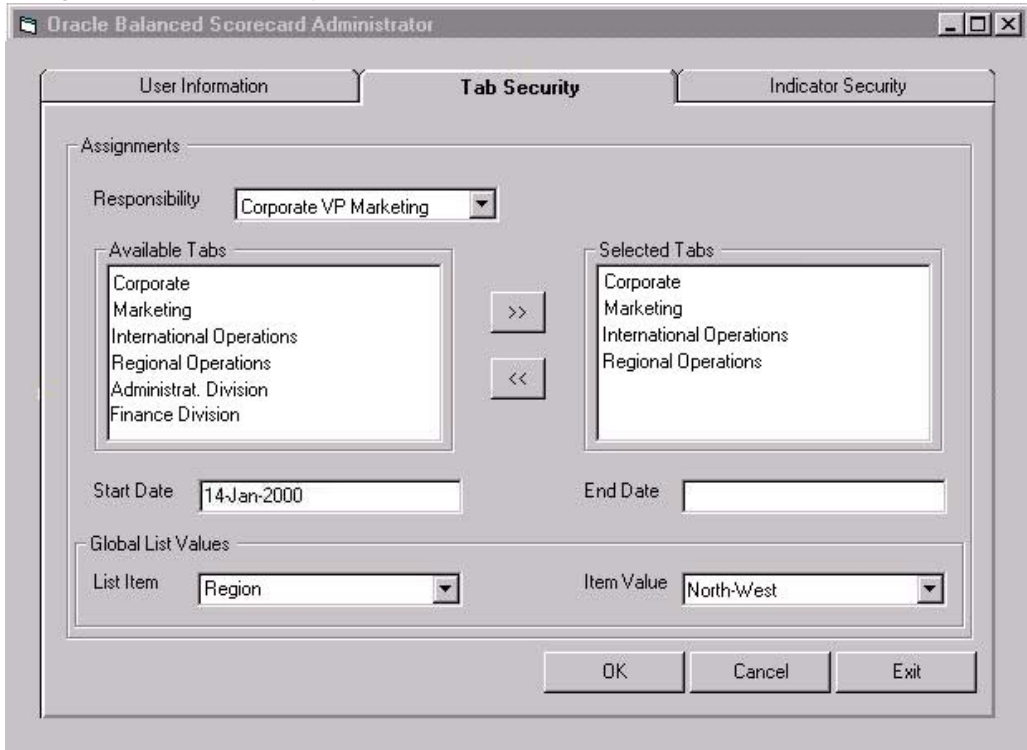

Administering Tab Access One of the main uses of Administrator is to control and define access privileges to specific balanced scorecards. Access can be defined according to job function, duty scope or expertise. For instance, while a business unit manager needs to see scorecards for product availability, unit volumes and margins for a specific product, he may not need to see tabs unassociated with his product, region or span of control.

►► To grant users access to a tab:

1. Highlight the name of the scorecard in the Available Tabs list.

Figure 8–3 Available Tabs List

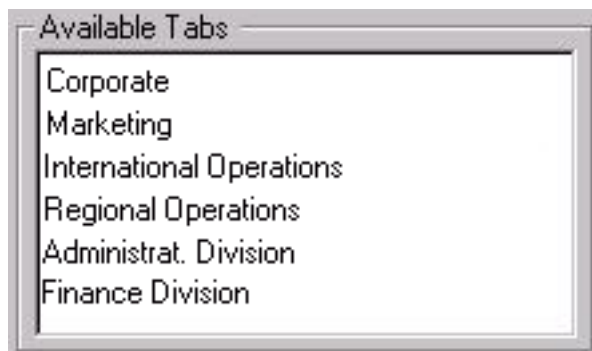

2. When you have selected the appropriate tab, click the double-right-arrow button. The selected tabs appear in the Selected Tabs panel:

Figure 8–4 Selecting Tabs From the Available Tabs List

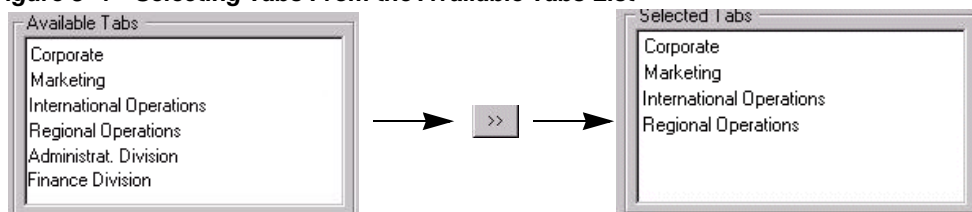

3. Select one tab in the Selected Tabs panel.
4. Enter a date in the Start Date field. This is the date when the access settings become effective. You can use the same settings for each scorecard or vary settings according to administrative priorities. However, you must use a valid date format (either 15-Jun-2000 or 6/15/2000).

Note: Notice that once a tab has been assigned you cannot un-assign it. If you want to restrict the access to that tab to a particular responsibility after you have assigned the tab once, you have to use the "End Date field".

Figure 8–5 Start Date Field

A screenshot of a user interface element. It consists of a light gray rectangular box with a thin border. On the left side of the box, the text "Start Date" is displayed in a dark gray font. To the right of the text is a white rectangular input field with a thin border, currently empty.

5. Enter a date in the End Date field (the date when the settings expire). The Dates can not be older than the current day.

Figure 8–6 End Date Field

A screenshot of a user interface element. It consists of a light gray rectangular box with a thin border. On the left side of the box, the text "End Date" is displayed in a dark gray font. To the right of the text is a white rectangular input field with a thin border, currently empty.

6. If the user has access to more than one tab, continue selecting tabs and entering start and end dates until all tabs have been defined.

Setting Global List Values Use the Global List Values feature to choose dimensions common to all the KPIs on a given scorecard and use them as a filter. For example, if you chose to restrict access to a value such as “East Region”, scorecard data would be filtered and the alarm colors on the main panel would be calculated to show values for the East Region dimension value.

The common dimensions available to users are defined using the BSC Architect wizard. To define actual dimension values that users have access to, use the List Item Value drop-down. For more information on using the List Button, see Chapter 3, "BSC Builder", section titled "Using the List Button".

Setting Item Value Use the Item Value feature when you need to filter scorecard data so that a user sees only one data dimension from a dimension set. For example, if you are creating a scorecard for the Sales Manager of the western region, you may only want to display an Item Value of “West” for the “Region” dimension set. This would allow a Sales Manager to see sales results for the West region only.

►► To define an item value:

1. From the List Item pull down menu, select a common dimension. The Item Values pull-down menu will now list all the dimension values for this dimension.
2. From the Item Values menu, select a dimension value. The user’s balanced scorecard displays data for the selected dimension value only. The alarm colors are calculated based on the dimension value and the user will not have access to any other drill-down values from the dimension set.

Note: Notice you can select only 1 value per dimension.

Indicator Security

In addition to setting access privileges for tabs by user, you can control access to key performance indicators through the Indicator Security tab. Click on this tab and the following screen appears:

Figure 8–7 Indicator Security Window

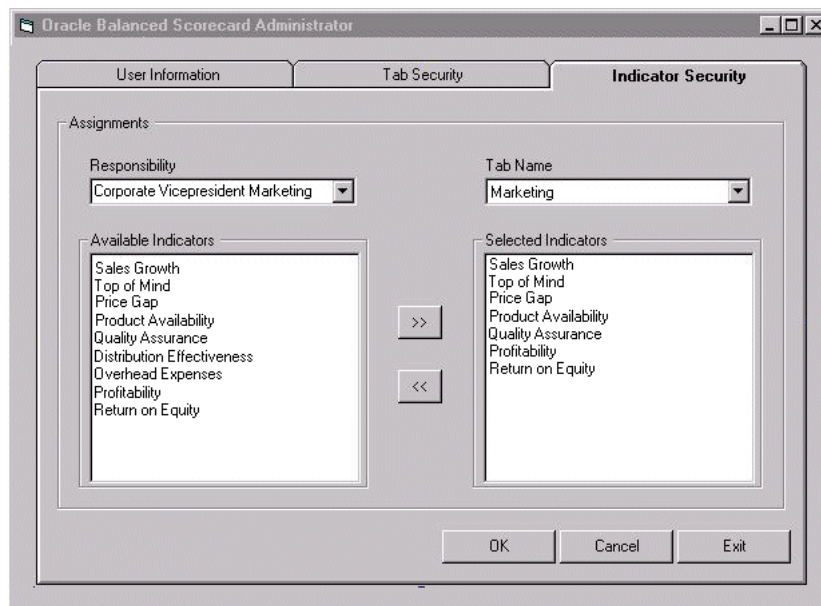

Use this tab to assign or restrict access to KPIs by responsibility and tab.

Assigning Access to KPIs by Responsibility and Tab

To allow access to a specific KPI to a user responsibility in a particular tab:

1. Within the Indicator Security tab, select a job title or division/group name from the Responsibility pull-down menu. This menu includes a list of job titles, such as Corporate Vice President Marketing and Executive Vice President-Channel Management:

Figure 8–8 Responsibility Assignments Menu

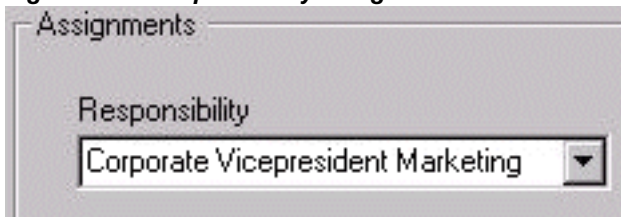

2. Select a tab from the Tab Name pull-down menu. For example, you might have tabs for different job functions such as Marketing, Sales or Distribution.

Figure 8–9 Tab Name Menu

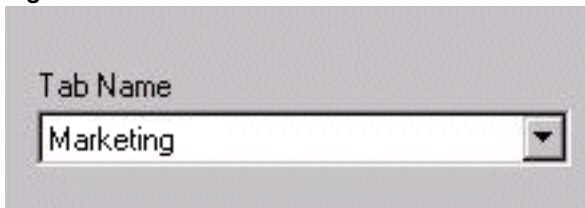

3. Next, choose a KPI from the Available Indicators panel. For example, you may want to give the Corporate Vice President-Marketing access to indicators that would affect his line of business such as Product Availability, Sales Growth and Quality Assurance. After you have highlighted the indicator you want to assign, click the right-arrow key.

The indicator appears in the Selected Indicators panel:

Figure 8–10 *Selecting Available Indicators*

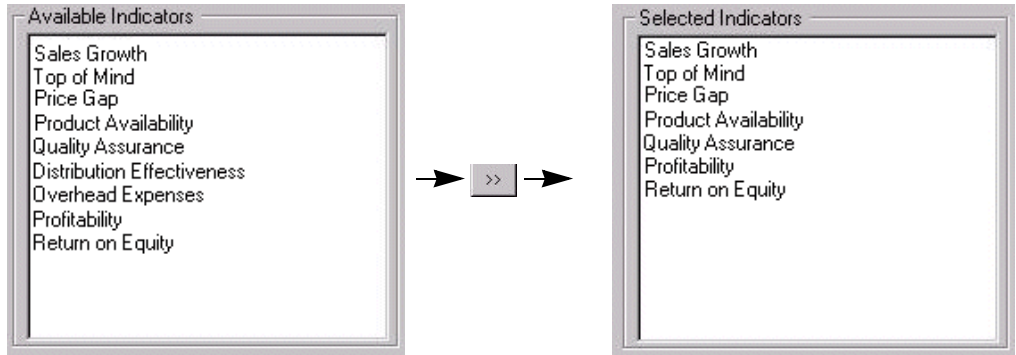

4. Continue assigning indicators to that tab within that responsibility. When you are finished, repeat steps 1-3 to continue assigning indicators to other tabs to which that responsibility has access. When you are finished, click OK.

Oracle Applications Security

When BSC is installed using the Self-Services Web Applications environment and Oracle Applications, elements of BSC security can be defined through Oracle Applications. These include many of the entities used by BSC Administrator, such as users and responsibilities.

Use Oracle Applications Forms to define responsibilities and assign responsibilities to users. Use BSC Administrator to define security per responsibility in terms of tabs and KPIs that can be accessed by users. For data on accessing Oracle Applications Forms refer to the *Oracle Applications 11.5.1 Administration Guide*.

Notes: In Enterprise database installations, the default system administrator user name/password is SYSADMIN/SYSADMIN.

►► To define responsibilities and users in Oracle Forms:

1. In the Balanced Scorecard responsibilities window, login as System Administrator.

Use the Balanced Scorecard Supervisor responsibility to submit processes to the Concurrent Manager.

Figure A-1 Oracle Applications Login Window



2. Define responsibilities through the Functions tab on the Navigator.

Figure A-2 Oracle Applications Navigator, Responsibility Definition

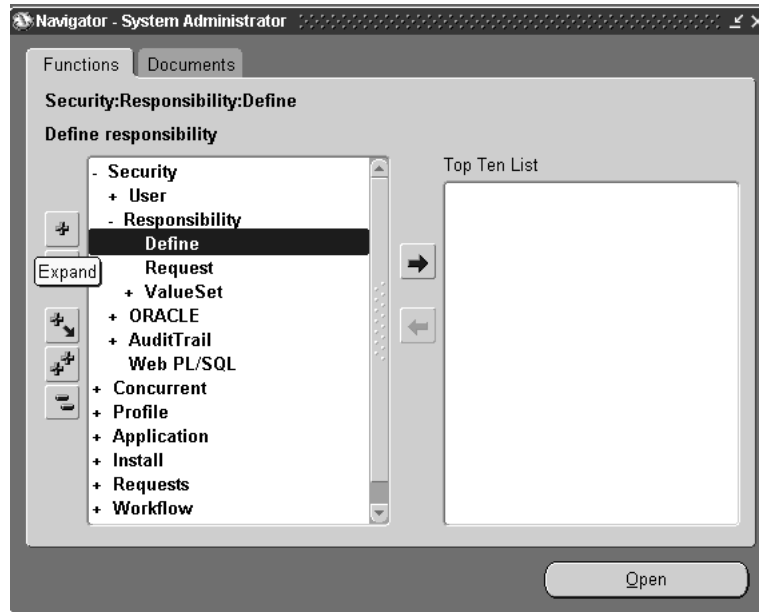

3. Create one or more responsibilities using the form in Oracle Applications. BSC has two seeded responsibilities: BSC Manager and BSC Supervisor. You can create other responsibilities based on roles in your organization. An example for CEO would be:

Application: Balanced Scorecard

Responsibility Key: BSC_CEO

Figure A-3 Oracle Applications, Responsibilities Window

The screenshot shows the Oracle Applications 'Responsibilities' window. The main configuration area includes the following fields:

- Responsibility Name: **Balanced Scorecard Manager**
- Application: **Balanced Scorecard**
- Responsibility Key: **BSC_MANAGER**
- Description: **Balanced Scorecard Manager**
- Effective Dates: From **11-FEB-2000**, To (empty)
- Available From: Oracle Applications, Oracle Self Service Web Applications
- Data Group: Name **Standard**, Application **Balanced Scorecard**
- Menu: **Balanced Scorecard**
- Request Group: Name **BSC VBConcurrent Request Group**, Application **Balanced Scorecard**
- Web Host Name (empty)
- Web Agent Name (empty)

Below these fields are three tabs: 'Menu Exclusions', 'Excluded Items', and 'Securing Attributes'. The 'Excluded Items' tab is active, showing a table with the following columns: Type, Name, and Description.

Type	Name	Description
Function		

At the bottom of the window, there are '<OSC>' and '<DBG>' buttons.

4. Return to the Functions tab in the Navigator to define users by expanding the user node and clicking Define.

Figure A-4 Oracle Applications Navigator, User Node

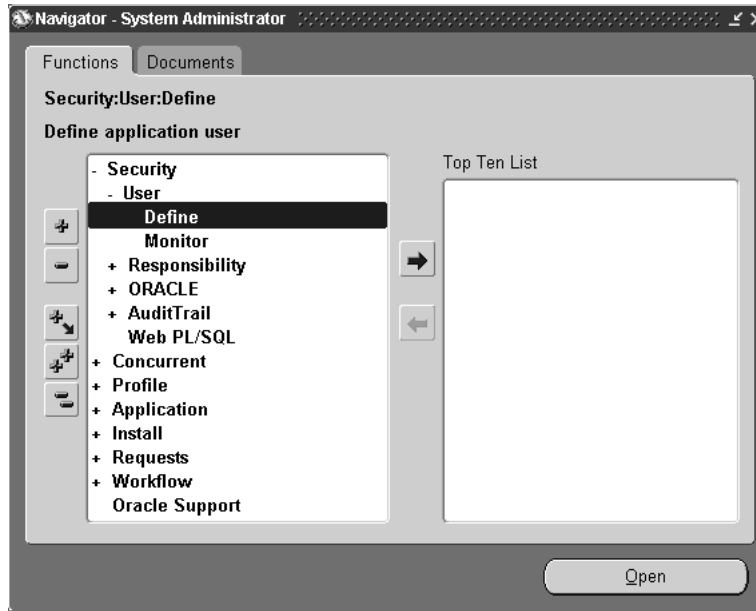

5. Assign one or more responsibilities to each user. In the example below, the user has three responsibilities assigned: Manager, Supervisor and CEO. The user will be able to login with any of these responsibilities. Be sure to note the password created for each user since this is the password he/she will need to gain access to the BSC Viewer once security is defined.

Figure A-5 Oracle Applications, Users Window

The screenshot shows the 'Users' window in Oracle Applications. The 'User Name' field is populated with 'JSMITH' and the 'Description' field with 'John Smith'. The 'Password' field is empty. The 'Password Expiration' section has three radio buttons: 'Days', 'Accesses', and 'None', all of which are unselected. The 'Effective Dates' section has a 'From' field with the value '07-APR-2000' and an empty 'To' field. Below these fields are two tabs: 'Responsibilities' and 'Securing Attributes'. The 'Responsibilities' tab is active, displaying a table with the following data:

Responsibility	Application	Security Group	Effective Dates	
			From	To
Balanced Scorecard Mana	Balanced Scorecard	Standard	07-APR-2000	
Balanced Scorecard Super	Balanced Scorecard	Standard	07-APR-2000	
CEO	Balanced Scorecard	Standard	07-APR-2000	

- Define security access for each responsibility created: Once users and responsibilities have been defined go to the BSC Manager and launch the BSC Administrator module. Login with User Name/Password: SYSADMIN/SYSADMIN.

Figure A-6 BSC Administrator, Tab Security

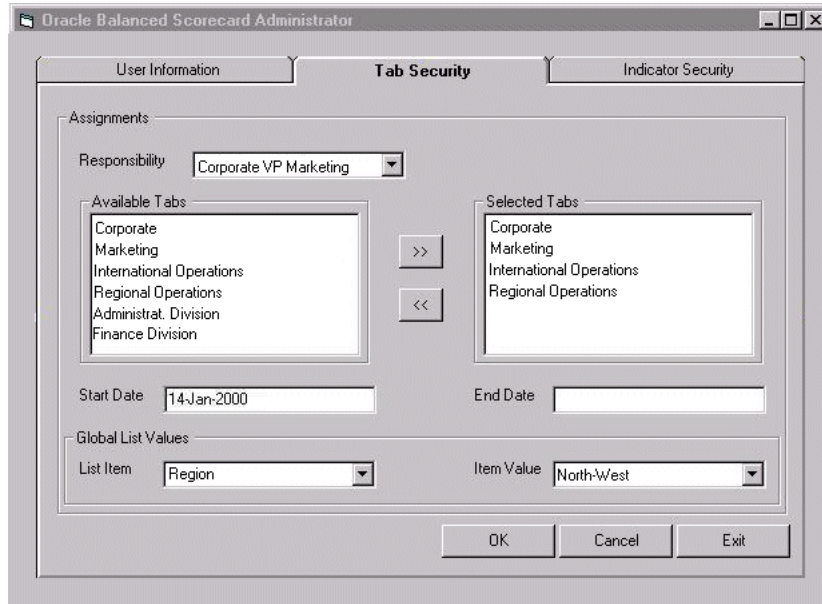

All the users assigned to a specific responsibility will have the access to the tabs and KPIs defined in BSC Administrator for that responsibility. In the example above, four tabs have been assigned to the Corporate VP-Marketing responsibility. All users with this responsibility will be able to access these four tabs. In addition to this you can also define the security access of the List button. In the example, the List Button has the Region dimension restricted to Northwest for this responsibility.

7. Once you have defined the tabs that each responsibility can access, define the indicators that can be accessed by the user within the tab defined.

Figure A-7 BSC Administrator, Indicator Security

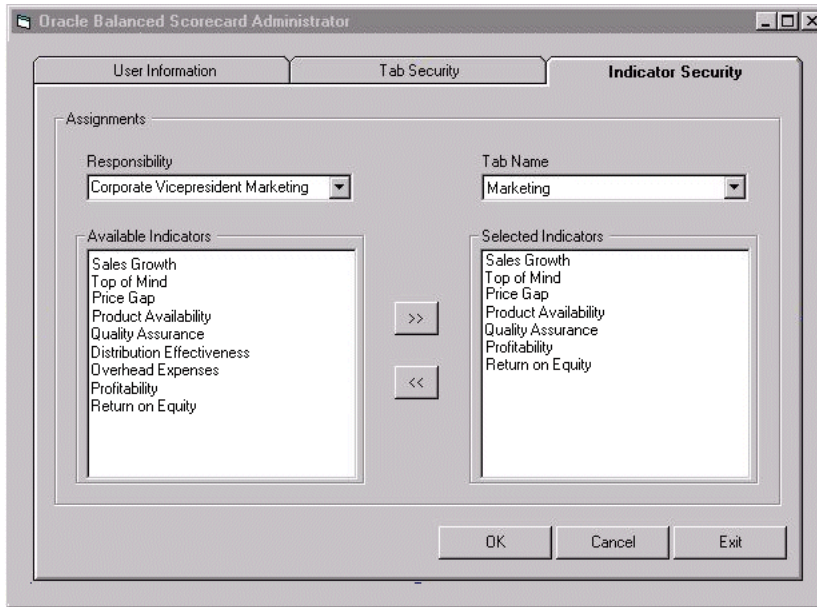

8. Now each user can login into the BSC Viewer with the password to view the tabs and KPIs defined according to the user's responsibility.

B

Scheduling Concurrent Requests

To load the BSC tables, you can use the Oracle Applications environment to schedule loads as concurrent requests. Once you are logged into Oracle Applications under the System Administrator privilege, select Supervisor Responsibility, access the Concurrent Requests screen through the Navigator as shown:

Figure B-1 Oracle Applications Navigator

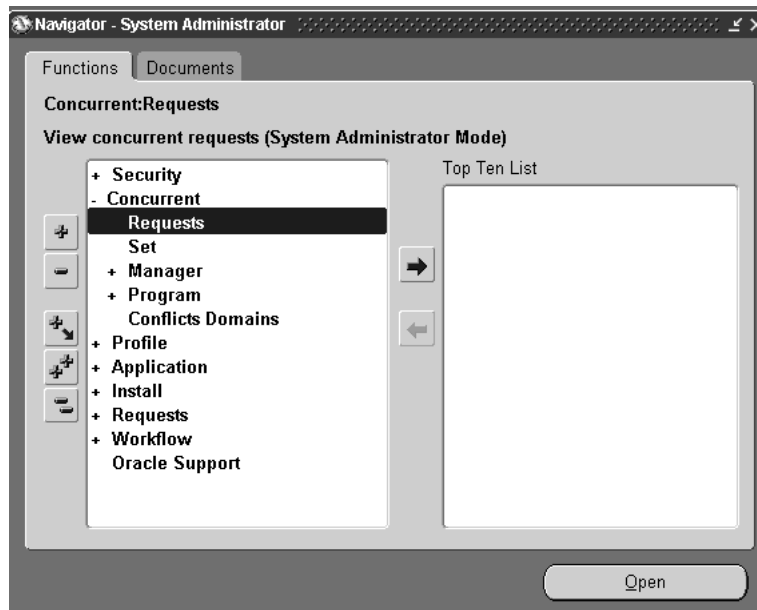

You can use this feature to schedule new requests or check status logs to see that table loads have completed successfully. You can also prioritize your requests and view the output of a request.

Figure B-2 Oracle Applications, Requests Window

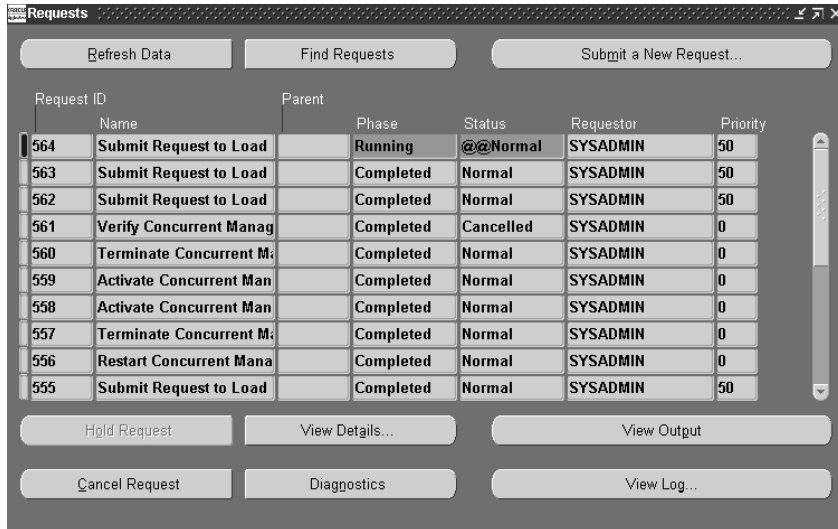

When the BSC application is run, a Request ID is assigned. Users can review this ID in the Requests window.

Multi-User Functionality

To implement a strategy and design a Balanced Scorecard system, you need the participation of multiple teams and people across the organization. From the beginning of the design process, the level of user involvement in the formulation and implementation of the scorecard is critical to the level of success the system has in the organization. The Balanced Scorecard tools permit and encourage this type of participation by allowing multiple people or teams to take an active part in the scorecard design process.

Before starting the design process, you must ensure that the vision and strategy for the scorecard is shared across all levels of the organization so integrated efforts and initiatives can be aligned, and multiple business units can take part in designing the system. Alignment and accountability between teams are critical elements when designing a Balanced Scorecard system, and multi-user functionality enables you to achieve this goal.

Multiple teams or people can work simultaneously on the design using the Balanced Scorecard's Architect, Manager, Setup and Viewer tools. These tools make it easier to create and implement scorecards for several different organizational levels or groups.

Multi-user functionality is especially useful during the design phase, before the balanced scorecard system goes into production. However, multiple users can work simultaneously at any stage of the balanced scorecard implementation, even after the system has been deployed to end users.

Working in a multi-user environment

Once the vision and strategy for the Balanced Scorecard system are clear, multiple users can simultaneously design multiple Scorecards, Key Performance Indicators, and other indicator details for the system.

Multiple users can work in the Architect and the Viewer tools at the same time, during design or after the Balanced Scorecard system has been deployed, since changes in the Architect are synchronized with the Viewer.

The Balanced Scorecard multi-user functionality is designed to keep data integrity and consistency, and to avoid conflicts between users when concurrent changes happen in the system or when multiple users try to access the same information.

Since multiple people or teams can work in the same environment, it is important to note that the multi-user functionality does not restrict any user from executing modifications at the system level. This means that all of your users should be careful when applying any system-level change that could affect other user configurations.

Note: The multi-user functionality is responsible for guaranteeing data consistency, synchronizing the changes between modules, and informing other users of the modifications applied; however, it does not handle security or protect changes done by multiple users. For this reason, it is very important to outline the design approach and agree on design rules before going to the actual design stage.

Working with multiple users in Architect

As shown in Figure 1-1, when multiple users work simultaneously in the Architect or Manager tools and apply changes to the system, those changes are propagated from the database to the users working in the Viewer.

The multi-user architect handles the synchronization logic for communicating changes to users in the Architect and Manager modules and users in the Viewer. From the users' point of view, when a change is applied to the system, the users receive an alert message informing them about the change.

Figure C-1 Figure 1-1. Multi-user Architect

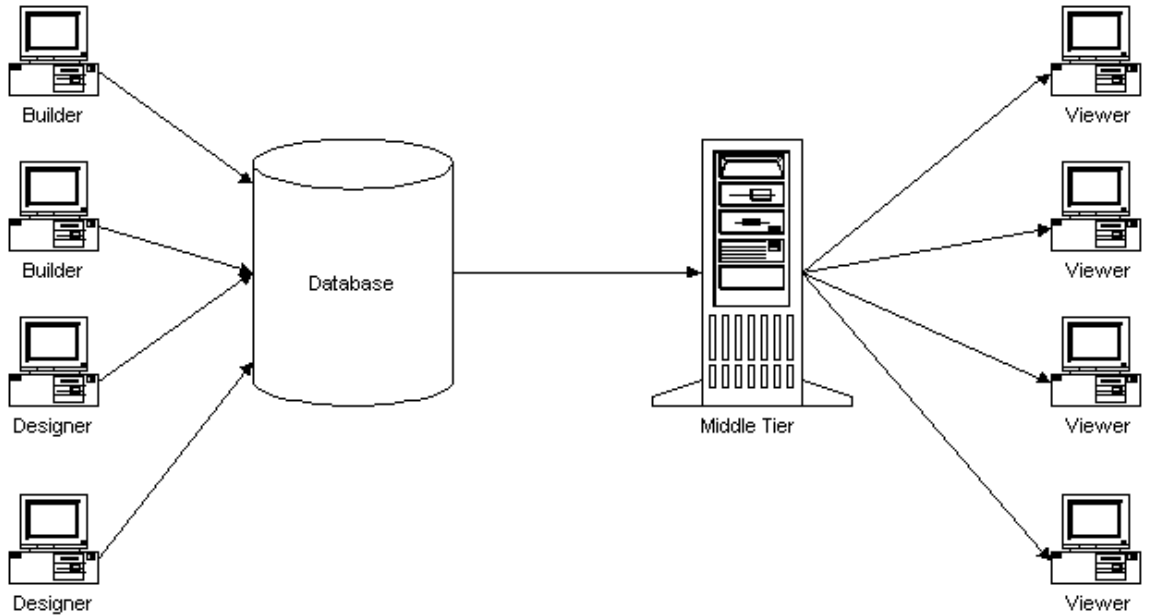

Synchronizing changes between multiple users

The Balanced Scorecard tools have several mechanisms that enable consistency while simultaneous users are working on the same or different modules. These mechanisms are responsible for keeping data integrity and for avoiding conflicts between multiple users when they attempt to apply modifications to the same component. These mechanisms are described in the following sections.

Locking mechanism for multiple users working in Architect or Manager

A “lock” mechanism guarantees data integrity and consistency when two or more people attempt to apply certain changes simultaneously. The lock controls which users have access to different levels of the system. For instance, when a user accesses a component, the system locks out other subsequent users, so they cannot access the component while the first user is committing the change.

When a user tries to access a component that has already been locked by another user, the new user will receive a message informing him or her that another user has already locked the component.

See the “Application Logic” section of this document for more information about the locking mechanism.

Synchronizing mechanism for populating changes to the Viewer

Whenever a change is applied and committed in the Architect or Manager modules, that change is propagated to the Viewer. Users who are working on the Viewer receive a message informing them that a change has been applied to the system.

Publishing mechanism for applying changes to indicators

If you change a key performance indicator after the Balanced Scorecard system has been deployed to end users, the indicator’s status can change from production mode to prototype mode.

You must be careful when you apply changes to key performance indicators, since the indicators are already being used to measure end user performance. Note that changing indicators also takes time: new tables are typically regenerated by the Metadata Optimizer and, in most cases, new data will be required.

The Balanced Scorecard publishing mechanism allows designers to disable key performance indicators in the Viewer, while they modify the indicators in the Architect or Manager. Once designers apply changes to indicators, they must publish the indicators to make them available to end users.

When designers disable an indicator, end users in the Viewer receive a message explaining that the indicator has not been published yet. Once the designers publish the indicator, the end user can again access the indicator in the Viewer.

Communicating changes to multiple users

Whenever a change is applied to the system, all concurrent users receive a message that the system, tab, or indicator has been modified.

The messages will appear when a user attempts to refresh, save, or apply any other change to the system. The messages vary depending on the type of change that is applied and on the components being used.

A description of the most common messages and situations are described in further detail in this chapter.

Locking applications at different levels

Multiple users can work simultaneously at different levels in the Balanced Scorecard design tools and the Viewer. However, some modules in the Architect

and the Manager tools can be accessed by only a single user. For instance, if one user is using Metadata Optimizer, all other users are locked out of that module.

The rules that govern multiple user access to the Architect and Manager modules are summarized in the following table.

Table C-1 Rules for Multiple User Access to OBSC Architect and Manager

INSTANCES	Builder	Designer	Metadata Optimizer	Viewer	Administrator Security	Loader
Builder	Allowed	Allowed	Locked	Allowed	Allowed	Locked
Designer	Allowed	Allowed	Locked	Allowed	Allowed	Locked
Metadata	Locked	Locked	Locked	Locked	Locked	Locked
Viewer	Allowed	Allowed	Locked	Allowed	Allowed	Allowed
Security	Allowed	Allowed	Locked	Allowed	Allowed	Locked
Loader	Locked	Locked	Locked	Allowed	Locked	Locked

Note on BSC Setup: The multi-user logic does not apply to setup tools, since they are typically used for system administration purposes, such as registering the system name, and migrating databases. It is assumed that setup tools are used only with system administration privileges and that all users will be aware of and out of the system during a possible migration. Do not allow users to use the system during a migration.

Multi-user logic in the system, tab, and KPI levels

Users can work in, apply changes to, and lock the Balanced Scorecard system on three major levels:

- System
- Tab
- Key Performance Indicator

The general logic for each level is described in the following sections.

System Level

System level changes are global changes that affect the whole system; for example, defining tabs, configuring global entities such as dimensions, data sets, benchmarks, or fiscal years, and all other changes that affect the status of the system.

When a user makes a system level change, other users will be notified that the system has been modified.

Tab Level

Tab level changes are changes that affect the same tab in the same or different modules. Users cannot apply changes simultaneously to the same tab.

If a user starts applying modifications to one tab, a second user will be temporarily locked, until the first user applies and saves the changes. Once the changes are applied and saved, the first user releases the tab and a second user can continue working on other changes.

Note: The lock remains in place for only a few seconds while the first user saves the changes. In a multi-user environment, all users should save their changes as soon as possible, to allow other users to continue working. For example, if a user starts working and forgets to close a window for an hour, that window will remain locked for the whole hour, and the tab or system may be locked as well. These locks will affect all other users.

Tab level changes are reflected as soon as the user saves or commits the applied change. When the change is saved, other users who are working in the same tab

will receive a message informing them that the tab has been changed, the tab will be refreshed, and they can keep working on the tab.

Typical examples of tab level changes include adding indicators, editing tabs, modifying layouts, adding groups, assigning or de-assigning indicators from the tab, and so on. Only the first user who controls the lock of the tab will be able to apply and save changes to the tab.

For a description of the behavior expected in tab level changes, refer to the “Global Behavior by modules in multi-user environment” section.

Note: Multi-user functionality guarantees data consistency and avoids conflicts by locking the system so changes cannot be simultaneously applied to tabs; however, it does not restrict users from applying modifications to tabs. This means pre-coordination work, such as defining owners for tabs, should be in place before starting to design the system, so no other users apply undesired changes.

Key Performance Indicator Level

Key performance indicator level changes are restricted to one user at a time, so that problems such as inconsistent data and conflicting indicator definitions are avoided. Two or more users cannot access the same indicator at the same time.

When a user changes an indicator, all other users are locked out of the indicator until the first user has committed the changes and has exited the indicator completely.

Within an indicator, there are global dimension definitions that affect the entire system. When a user applies changes will lock the component and other users cannot apply simultaneous changes until the component is released. The logic for each of these definitions is described in the following sections.

Dimension Definition

Dimensions are global definitions for the system, and, consequently, the dimension definition, or any change that is applied to an existing dimension definition, can affect multiple indicators.

For this reason, multiple users cannot work simultaneously in dimension definition in the same Balanced Scorecard system. The first user that accesses the dimension definition locks the window. The second user can only access the dimension

definition after the first user saves and commits the change and exits the window completely.

When changes are applied to a dimension, other users that are working in indicators that use the dimension will receive a message informing them that the indicator has changed.

Changing a dimension can also affect the system or tab status. For instance, if a tab has a list button and a user changes dimensions that affect the definition of that button, other users working on the tab will receive a message informing them that the tab has changed.

Data Set Definition

Data sets are also global definitions for the system. A user cannot delete a data set that is used by another indicator, but the user can modify important data set properties such as color method, formats, formulas, and so on., which can affect other indicators and tab defaults.

When a user changes the data set definition for an indicator, the window will be locked and no other users will be able to apply changes to that data set simultaneously. When the first user finishes the changes to the data set and closes the data set definition window, the data set will be released, refreshed, and other users can make changes.

Changing data set properties, such as color method for indicators, can affect the tab status. If the change affects the tab, users will receive a message that the tab has been modified.

Benchmarks Definition

Benchmarks are global definitions for the system. When a user creates, deletes, or changes a benchmark definition, the change occurs at the system level and affects the global list of benchmarks for all indicators in all tabs.

To avoid inconsistencies, when the first user opens a benchmark definition, the benchmark definition is locked and no other users can apply changes to benchmarks. The second user can only access the benchmark definition after the first user commits the changes and exits the window.

Cause & Effect Definition

Cause and Effect definitions are global definitions for the system. When a user changes a cause and effect relationship, the change affects all indicators defined in a particular tab.

The first user accesses the Cause and Effect definition, the window is locked at the system level and no other users can apply simultaneous changes until the window is released by the first user.

Alarm Color Definition

Two or more users can simultaneously access the color trigger definition window, as long as they are in different indicators. However, the section in this window where the user can customize the color of the alarm is restricted to one user at a time.

Customizing alarm colors is a global definition, since the alarm colors represent the status of all indicators in the system. Therefore, when the first user accesses the alarm color definition, the window is locked and no other users can change the alarm colors until the first user commits the changes and exits the window.

When a user changes an alarm color, the alarm colors is refreshed and other users will receive a message indicating the tab has changed the next time they login to the system or refresh their window.

Global Buttons Definition

Some buttons have global properties that can affect the system status;. for example, Messaging and Custom Help. If a user is working in the properties for a button with a global property, the button window will be locked until the properties are saved and no other users will be able to apply changes to the definitions.

Fiscal Year Definition

The Fiscal Year definition is a global definition. Two or more users cannot enter or change the Fiscal Year definition simultaneously. As with other global definitions, the first user that accesses the definition will lock the window. No other user will be able to modify this property until the changes are applied and the first user exits the window.

Global Behavior by modules in multi-user environment

Transactions at System Level

Many transactions affect the system as a whole, including Add or Remove Tabs, Create Indicators, Create Groups, Define Dimensions, and so on. In general, two users cannot simultaneously apply system level changes; for example, a user cannot remove a tab while another user is simultaneously adding a tab.

In general, users will not try to make system level changes simultaneously. However, you should be aware of this restriction.

The following section contains a summary of the most important transactions and how the behavior may change when simultaneous users work in those transactions. The tables discuss some typical situations and how these different situations may affect users.

Transactions by Module

The following sections summarize the expected behavior for each transaction available in the BSC Builder, KPI Designer, Metadata Optimizer, Viewer, and BSC Manager modules.

BSC Builder

A user in BSC Builder can work simultaneously with other users in KPI Designer, Viewer, and Administrator. They can also work simultaneously with other concurrent users in BSC Builder.

BSC Builder has two levels; each level is represented in one of BSC Builder's two main windows (See BSC Builder page 3-2 Administration Guide). The first window is used to make system level changes such as creating indicators, defining indicator names, and defining indicator groups. The second window is used to make system and tab level changes such as creating, removing, or moving tabs (which are system level changes) or assigning indicators to tabs and filters, and defining list buttons (tab level changes).

In a multi-user environment, the transactions listed in the following table create a temporary lock while the first user finishes and saves the changes in BSC Builder. This means a second user will be temporarily locked if that second user tries to apply simultaneous changes while another user is making modifications. In most cases, these locks last a few seconds and happen only if simultaneous users try to work in the same function at the same time.

Table C-2 User Actions in OBSC Builder and Associated Change Behavior

User action in Builder	Behavior while changes are applied*
<ul style="list-style-type: none"> ▪ Add Group ▪ Edit Group Properties 	<ul style="list-style-type: none"> ▪ Temporary lock for other users who attempt to apply modifications in the same Builder window; for example, if the users try to add indicators, remove indicators, or edition functions at the same time. ▪ Refreshes at system level.
<ul style="list-style-type: none"> ▪ Delete Groups 	<ul style="list-style-type: none"> ▪ Temporary lock in tabs while group is deleted. ▪ Refreshes at system level.
<ul style="list-style-type: none"> ▪ Add Indicator 	<ul style="list-style-type: none"> ▪ Temporary lock (a few seconds) for concurrent users who try to add indicators at the same time. ▪ Temporary lock of other functions happening in the same builder window such as removing indicators or editing functions. ▪ Refreshes at system level.
<ul style="list-style-type: none"> ▪ Delete Indicator ▪ Move Indicator 	<ul style="list-style-type: none"> ▪ Temporary lock for other users who attempt to apply modifications in the same Builder window. ▪ Locks other users who try to access or assign the KPI in any window ▪ Locks other users who try to modify the tab where indicator is being used ▪ Refreshes at system level.
<ul style="list-style-type: none"> ▪ Copy Indicators (from same system or source system) 	<ul style="list-style-type: none"> ▪ Locks indicators in the source and target system ▪ Locks dimensions and data sets in the source and target system ▪ Locks other users working in the same Builder window ▪ Refreshes at system level.
<ul style="list-style-type: none"> ▪ Edit Indicator 	<ul style="list-style-type: none"> ▪ Locks the same indicator edition for other users
<ul style="list-style-type: none"> ▪ Edit System, Groups or Indicators 	<ul style="list-style-type: none"> ▪ Temporary lock for other users who attempt to apply modifications in the same Builder window.
<ul style="list-style-type: none"> ▪ Add Tab 	<ul style="list-style-type: none"> ▪ Locks other users who try to add, remove, or move tabs at the same time. ▪ Refreshes at system and tab level.

Table C-2 User Actions in OBSC Builder and Associated Change Behavior

<ul style="list-style-type: none"> ▪ Remove Tab 	<ul style="list-style-type: none"> ▪ Locks other users trying to add, remove, or move tabs at the same time. ▪ Refreshes at system and tab level. ▪ It can also lock dimensions if a list button is defined in the tab.
<ul style="list-style-type: none"> ▪ Move Tab 	<ul style="list-style-type: none"> ▪ Locks other users who try to add, remove, or move tabs at the same time ▪ Locks the tabs that are positioned next to the tab being moved ▪ It can temporarily lock dimensions used in the tab since dimension filters are also moved. ▪ Refreshes at system and tab level.
<ul style="list-style-type: none"> ▪ Edit Tab 	<ul style="list-style-type: none"> ▪ Locks other users who try to edit same tab at the same time. ▪ Refreshes at system and tab level.
<ul style="list-style-type: none"> ▪ Assign or un-assign groups from tabs 	<ul style="list-style-type: none"> ▪ Temporary lock of the tab while indicators are assigned ▪ Refreshes tabs.
<ul style="list-style-type: none"> ▪ Define or Modify List Button 	<ul style="list-style-type: none"> ▪ Tab locked for modifications while changes are saved. ▪ Refreshes tab.
<ul style="list-style-type: none"> ▪ Define filters 	<ul style="list-style-type: none"> ▪ Tab locked until first user releases the filter's window. ▪ Refreshes tab.

KPI Designer

Users in the KPI Designer can work simultaneously with users in the Builder, Viewer, and Administrator, as well as with other concurrent users in KPI Designer.

As in BSC Builder, users can make several system level changes in KPI Designer, such as changing dimension, benchmark, and fiscal year definitions. For system level changes, concurrent users cannot simultaneously use the same functionality or save the same type of changes.

Users can also make other types of changes in KPI Designer. For example, a user can make a change that affects only a particular indicator, such as changing the definitions for periodicity or calculations. For these types of changes, a lock is placed at the indicator level. Therefore, the same indicator cannot be accessed by multiple users at the same time, but different indicators be modified simultaneously by different users.

The following table shows a summary of the main transactions and expected behavior for actions performed in KPI Designer.

Table C-3 User Actions in KPI Designer and Associated Change Behavior

User action in KPI Designer	Behavior while changes are applied*
<ul style="list-style-type: none"> ▪ Modify Scorecard view ▪ Enable/Disable Scorecard View ▪ Add & Delete Lines ▪ Change Group Position 	<ul style="list-style-type: none"> ▪ Locks tab for other users until the first user saves changes and refreshes the tab.
<ul style="list-style-type: none"> ▪ Modify Strategy Map View ▪ Enable/Disable Strategy Map ▪ Add KPI ▪ Delete KPI ▪ Change KPI properties ▪ Add & Remove Lines ▪ Add & Remove division lines ▪ Add and remove division labels ▪ Zoom Out-Zoom In ▪ Increase & Decrease Fonts 	<ul style="list-style-type: none"> ▪ Locks tab for other users until the first user saves changes and refreshes the tab.
<ul style="list-style-type: none"> ▪ Define Dimensions or change dimension properties 	<ul style="list-style-type: none"> ▪ Locks dimension window for other users and refreshes the affected indicators.
<ul style="list-style-type: none"> ▪ Modify dimensions affecting list button or filters 	<ul style="list-style-type: none"> ▪ Locks dimension window and refreshes affected tab and indicators.
<ul style="list-style-type: none"> ▪ Add or modify data sets 	<ul style="list-style-type: none"> ▪ Locks other users trying to modify datasets and refreshes indicators.

Table C-3 User Actions in KPI Designer and Associated Change Behavior

<ul style="list-style-type: none"> ▪ Add Analysis Group ▪ Edit Analysis group ▪ Delete Analysis group ▪ Add Analysis option ▪ Delete Analysis option ▪ Edit analysis properties ▪ Define Periodicity ▪ Modify periodicity properties ▪ Define Calculations ▪ Modify calculations defaults ▪ Define Simulation Tree with all properties and formulas 	<ul style="list-style-type: none"> ▪ Since these definitions happen by indicator, and multiple users cannot enter to the same indicator at the same time, users can simultaneously define analysis, periodicity, and calculations for different indicators.
<ul style="list-style-type: none"> ▪ Define or modify Benchmarks 	<ul style="list-style-type: none"> ▪ Locks benchmark definition for other users and refreshes system changes.
<ul style="list-style-type: none"> ▪ Define Cause & Effect 	<ul style="list-style-type: none"> ▪ Locks Cause and Effect definition and refreshes indicator and system.
<ul style="list-style-type: none"> ▪ Define Color Triggers without customizing alarm colors 	<ul style="list-style-type: none"> ▪ Locks the indicator.
<ul style="list-style-type: none"> ▪ Define Color Triggers customizing alarm colors 	<ul style="list-style-type: none"> ▪ Locks the window for other users and refreshes tabs and system.
<ul style="list-style-type: none"> ▪ Define Global User Buttons ▪ Messaging ▪ Custom Help 	<ul style="list-style-type: none"> ▪ Locks window for properties definition.
<ul style="list-style-type: none"> ▪ Define User Buttons (Exporting to Excel, Link Options, Projection, User Wizard) 	<ul style="list-style-type: none"> ▪ Locks the indicator.
<ul style="list-style-type: none"> ▪ Define Fiscal Year 	<ul style="list-style-type: none"> ▪ Locks other users who try to modify the Fiscal Year definition and refreshes at the system level.
<ul style="list-style-type: none"> ▪ Define Key Items 	<ul style="list-style-type: none"> ▪ Locks other users who try to define key items for other indicators and locks the dimension definition. This action refreshes the indicator and the tab.

* The lock happens for only a few seconds while the action executed by the first user is completed and only if another user tries to access the same window at the same time. In most cases, users will not notice this lock.

User Messages

In general, whenever you make a change to the system, a message is sent to all other users working at the time that the system, the tab, or the KPI has changed. For system or tab level changes, the message generally appears when users refresh a tab or exit an indicator. For indicator level changes, the message appears while the user is working on the KPI.

Special Note in KPI Designer for indicators in production

When an indicator is in production mode and users apply structural changes to that indicator, the indicator may return to prototype mode. This change of status needs to be smooth for the users who are working in the Viewer; therefore, the KPI Designer enables users to publish or disable indicators while they apply changes.

When a you attempt to change an indicator that is already in production, KPI Designer will ask you if you want to publish the indicator for users in the Viewer. If you publish the changed indicator, the indicator will be made available to users in the Viewer. However, if you do not publish the indicator, the users in the Viewer will receive a message that the KPI has not been published due to modifications.

Metadata Optimizer

The Metadata Optimizer module works in a single user mode depending on the configuration that is applied to other modules, such as KPI Designer and BSC Builder. The Metadata Optimizer affects other modules such as Loader and Security. For this reason, only one user can enter data into the Metadata Optimizer at a time. All other applications will be locked while Metadata is running. Similarly, if other modules are opened, no one can use the Metadata Optimizer.

Loader

The Loader can work simultaneously with the Viewer, but all other modules are locked while the Loader is running. While changes are applied to the Loader or new data is being loaded, Viewer users will receive a message that the system, tab, or indicator has changed.

Generally, all transactions in the Loader generate a temporary, system level lock while the transaction is completed. The following table shows a summary of the main transactions and expected behavior for actions performed in the Loader.

Table C-4 User Action in OBSC Loader and Associated Change Behavior

User action in Loader	Behavior while changes are applied*
▪ Update, add or modify dimension values	▪ Refreshes at system level
▪ Load input tables	▪ Refreshes system, tab and indicators affected by loading
▪ Change Year	▪ Refreshes at system level

Security in Administrator

The Security module can work simultaneously with all other modules except the Metadata Optimizer. The following table shows a summary of the main transactions and expected behavior for actions performed in the Security module.

Table C-5 User Action in Security and Associated Change Behavior

User action in Security	Behavior while changes are applied*
▪ Update/add or modify user information	▪ No locks are applied to this action
▪ Assign tabs by responsibility	▪ na
▪ Assign indicator to responsibility by tab	▪ Temporary lock for tabs used in the action

Working with multiple users in the Viewer

Multiple users working in the Viewer will be alerted of all changes that happen in the Architect or Manager tools while they are using and navigating the system.

Basically, the Viewer's behavior is to generate messages that indicate the type of change that is applied to the system, tab, or indicator that the user is using.

Changes at the system, tab, and indicator level affect all Viewer users.

System level changes include creating or removing tabs, modifying dimensions, adding or removing indicators, and all other modifications that may affect the structure of the system and all indicators. If a system level change occurs, the user receives a message indicating that the system has been modified and how to refresh the changes.

When a tab level change occurs (for example adding tabs, assigning new indicators, changing filters, and so on) users will receive a message that the tab has changed. In this case, the users must accept the message before the tab will be refreshed.

When an indicator level change occurs (for example changing analysis, periodicity, and calculation options) users receive a message that the indicator has changed and that the changes have been refreshed.

When an indicator that is already in production is changed (See "Special Note in KPI Designer for indicators in production stage"), and the user who made the change decides not to publish the indicator, the users in the Viewer will receive a message that the indicator has not been published and the indicator will be disabled.

Index

A

access, scorecards, 7-2
access, tabs, 7-2
account types, 4-31
adding an OBSC system, 2-5
alarm color, comparison graphs, calculating, 4-76
alarm color, simulation trees, calculating, 4-76
alarm color, trend graphs, calculating, 4-76
alarm color, user customization of, 4-78
alarm colors, 4-71
analysis group dimensions, modifying, 4-21
analysis groups, 4-18
analysis groups, creating, 4-20
analysis option, default, defining, 4-74
analysis options, 4-18, 4-20
analysis options, assigning datasets to, 4-21
analysis options, assigning dimension sets to, 4-58

B

balanced scorecards, creating, 3-13
benchmarks, 4-66
BSC Builder, 3-1
BSC Loader, 6-1
BSC Setup, 2-1

C

calculated KPIs, 5-4, 5-6
calculation options, 4-64
Calculations, 4-64
calculations, 4-64
calculations, year to date as default, 4-65

cause and effect relationships, defining, 4-70
cause-effect analysis, 4-69
changes, KPI, structural and non-structural, 7-4
client modules, 1-2
color method, definition of, 4-76
color triggers, 4-72, 4-76
color triggers, simulation tree KPIs, 4-98
comparison graphs, alarm color, calculating, 4-76
configuring an OBSC system, 2-4
creating a database link, 2-16
creating an OBSC system, 2-3
creating and modifying groups, 3-4
custom help, 4-80

D

data dimensions, 4-44
data dimensions, creating, 4-44
data source name, 2-7
data source properties, defining, 4-30
data source, assigning to dataset, 4-25
data sources, using, 4-21
database setup, 2-3
dataset, assigning data source to, 4-25
dataset, assigning properties, 4-23
datasets, assigning to analysis options, 4-21
datasets, defining, simulation tree KPIs, 4-94
datasets, using, 4-21
defining key items, 4-55
deleting an OBSC system, 2-8
dimension group, dimension properties in, 4-51
dimension groups, 4-47
dimension groups, assigning to dimension sets, 4-52

- dimension groups, moving, 4-55
- dimension properties in dimension group, 4-51
- dimension properties in dimension set, 4-57
- dimension properties, ALL, 4-51, 4-74
- dimension properties, COMPARISON, 4-51, 4-74
- dimension relationships, 4-49
- dimension set, dimension properties in, 4-57
- dimension sets, 4-52
- dimension sets, assigning to analysis options, 4-58
- dimension tables, maintaining, 6-2
- dimension value filtering, 7-3
- dimension value security, 7-3
- dimension values, loading, 6-1
- dimension values, updating, 6-2
- dimension values, viewing in tables, 6-2
- dimensions, analysis group, modifying, 4-21
- dimensions, assigning to dimension groups, 4-48
- dimensions, data, 4-44
- dimensions, data, creating, 4-44
- dimensions, moving within group, 4-54
- dimensions, relationship properties, defining, 4-50

E

- exporting an OBSC system, 2-12
- exporting data to Microsoft Excel, 4-83

F

- filter, KPIs by dimension, 3-21
- filter, KPIs by dimension by tab, 3-27
- filtering, dimension value, 7-3
- filtering, list button versus by tab, 3-28
- fiscal year and month, setting, 4-68
- forecast configurations, 4-37
- forecasts, configuring, 4-35
- formula datasets, 4-26
- formula datasets, special, 4-27

G

- global list values, 7-3
- global list values, setting, 7-8
- graphs, comparison, calculating alarm color, 4-76
- graphs, trend, calculating alarm color, 4-76

- group properties, 3-6
- groups, creating and modifying, 3-4
- groups, removing, 3-7

H

- help, custom, 4-80

I

- images, configuring, 3-2
- implementation OBSC system, creating, 7-2
- implementation stage, 7-1, 7-2
- importing an OBSC system, 2-10
- indicators, copying between groups, 3-11
- indicators, creating, 3-9
- indicators, defining properties of, 3-9
- indicators, layout, formatting of, 4-2
- indicators, multiple bar, 3-10
- indicators, multiple bar, configuring, 4-40
- indicators, profit and loss, 3-10, 3-11, 4-99
- indicators, simulation tree, 3-10, 4-90
- indicators, single bar, 3-10
- input tables, 5-15
- item values, setting, 7-8

K

- key items, defining, 4-55
- KPI Designer, 1-3
- KPI designer, 4-1
- KPI properties, setting, strategy map view, 4-9
- KPI settings, global, defining, 4-59
- KPI structural and non-structural changes, 7-4
- KPI, assigning dimension groups and sets to, 4-52
- KPIs, access to by responsibility and scorecard, assigning, 7-9
- KPIs, copying between groups, 3-11
- KPIs, creating, 3-9
- KPIs, defining properties of, 3-9
- KPIs, layout, formatting of, 4-2
- KPIs, modifying in production stage, 7-4
- KPIs, multiple bar, 3-10
- KPIs, multiple bar, configuring, 4-40
- KPIs, profit and loss, 3-10, 3-11, 4-99

KPIs, simulation tree, 3-10
KPIs, single bar, 3-10
KPIs, updating during implementation stage, 7-3

L

launchpad, 4-83
layout, balanced scorecard views, formatting, 4-2
links button, 4-83
list button, 3-21
list button, restrictions, 3-27
list button, setup, 3-24
Loading, 6-4
loading BSC tables, 6-4
loading dimension values, 6-1
log files, 5-8

M

master KPIs, 3-16
master KPIs, configuring, 4-13
mdresult.txt file, 5-8
messaging, security, 7-10
Metadata Optimizer, 1-3, 5-1
Metadata Optimizer, configuring, 5-3
migrating a source to a target system, 2-15
modifying an OBSC system, 2-7
month and year, setting, 4-68

O

OBSC Administrator, 1-4, 7-1
OBSC Architect
 BSC Builder, 1-3
OBSC design process, 5-2
OBSC Manager
 BSC Loader, 1-4
OBSC Setup, 1-2, 2-1
OBSC Viewer, 1-4
Oracle Corporation, xx

P

periodicity, 4-60
populating and deploying OBSC, 1-5, 7-1

pre-calculated KPIs, 5-4, 5-7
production stage, 7-1, 7-4
profit and loss indicators, 3-11
prototype color, 4-77

R

registered names, modifying properties for, 2-4
registered system name, 2-4
registered system name, adding, 2-5
registered system name, deleting, 2-8
registered system name, modifying, 2-7
relationship properties, defining, 4-50
responsibilities, user, defining, 7-2
responsibility, access to KPIs by, assigning, 7-9
rollup properties, defining, 4-30

S

scorecard access, administering, 7-5, 7-6
scorecards, access to KPIs by, assigning, 7-9
scorecards, assigning KPIs to, 3-16
scorecards, creating, 3-13
security, dimension value, 7-3
security, indicator, 7-8
security, KPI, 7-4, 7-8
service name, 2-7
setting up a database, 2-3
setup stage, 7-1
shared KPIs, 3-16
shared KPIs, configuring, 4-13
simulation tree indicators, 4-90
simulation trees, alarm color, calculating, 4-76
source group lists, creating, 4-29
source system for balanced scorecard elements, 3-8
stages, OBSC deployment, 7-1
strategy map view, 4-5
system configuration, 2-4
system description, 2-7
system images, configuring, 3-2
system name, 2-7
system tables, 5-15
system.txt file, 5-8
systree.xls log, 5-8

T

tab, access to KPIs by, assigning, 7-9
tables, 5-15
tables, changing current year, 6-9
tables, defining data source, 6-4
tables, deleting data, 6-9
tables, dimension, maintaining, 6-2
tables, pre-calculated KPIs, populating, 6-6
tables, scheduling autoloading, 6-9
tabs, scorecard, assigning KPIs to, 3-16
tabs, scorecard, creating, 3-13
tabs, scorecard, reordering, 3-15
test OBSC system, creating, 7-2
trend graphs, calculating alarm color for, 4-76

U

upgrading the system version, 2-12
user buttons, 4-80
user responsibilities, defining, 7-2
user types, 1-4
user wizard, 4-85

V

version, upgrading, 2-12
views, KPI, configuring, 4-3
views, strategy map, 4-5

W

what-if simulations, 4-90

Y

year and month, setting, 4-68