



Oracle Spatial Users Conference

April 27, 2006
Tampa Convention Center
Tampa, Florida, USA

ORACLE

SPATIAL

April 2006

Oracle Spatial Users Conference

Giovanni Corcione

Senior Sales Consultant

Spatial – Oracle Italy

giovanni.corcione@oracle.com

ORACLE

SPATIAL

April 2006

Oracle Spatial Users Conference

Topographic-DB Updating

**Persistent Topology Data Model
Updating Process Management**

ORACLE

SPATIAL

April 2006

Oracle Spatial Users Conference

Agenda

- Cartographic Context
- Architectural Context
- Updating T-DB: Project Requirements
- Cultural Background
- Topographic-DB Setup
- Applicative Infrastructure
- Features Composition: automatic / interactive
- Updating: cleansing, commit
- DbMap ASJ ABACO tools

Cartographic Context: Italian Admin-Boundaries



- Country
 - Regions
 - Provinces
 - Cities (Towns)

• Regione Sicilia

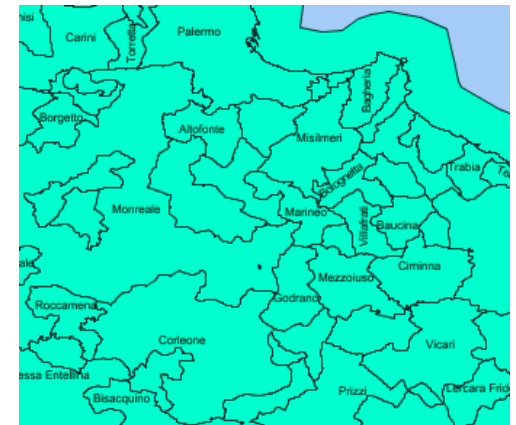
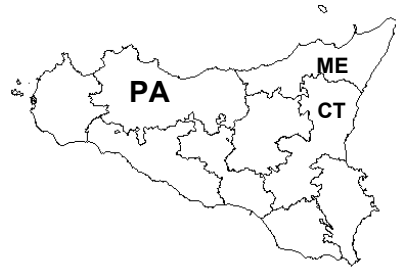

Architectural Context

- SIGMATER like: soa based italian e-gov project.
- Consortium Comuni (towns) Bolzano exchanges (cartographic) data with its relevant municipalities:
- SDI is continuously updated thanks to town co-operations

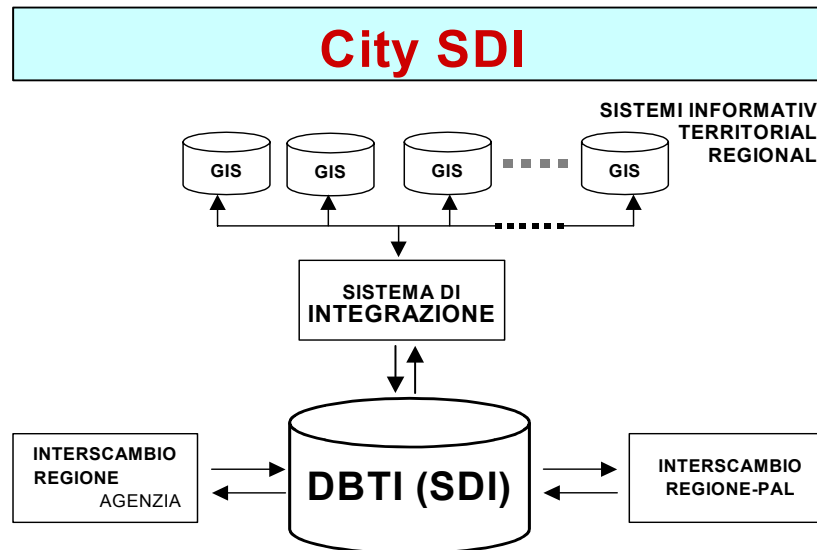

Topographic-DB:

- Requirements & Assumptions
 - **TopographicTables** the most granular layer for City Technical Cartography: greenArea, buildings and Streets.
 - **TopographicTables** updated by new topographic features **interchanged** between peripheral co-operative systems.
 - Topographic objects are taken from DBTI: via **ws** or direct access
 - Objects are modified separately to DBTI
 - New and modified topographic objects, then *delivered* to DBTI, again, via **ws** or sql direct access
 - OGC polygons: **touch** or **disjoint** topology relationship, no overlapping nor intersection.
 - **NEW_OF** table topographic features: an ID, an OGC polygon, a base granular layer, and an id_session
 - Automatic and interactive updating modality.

ORACLE

SPATIAL

April 2006

Oracle Spatial Users Conference

TOID

Topographic Object Identifier

*Master Map's organizing principle is a convention with an unusual name: the "**Topographic Object Identifier**" or **TOID**. A TOID is a unique, persistent identifier for geographic objects as small as two centimeters. This means that every building, road segment, and railroad track . or any other geographic feature . in Britain can be uniquely identified and have an essentially unlimited amount of data associated with it. For example, a building may be associated with records about the owners, taxes paid, historical use, current and past valuations, construction materials, hazardous materials present, or anything else.*

*The TOID convention also provides a persistent point for data **interchange** between Ordnance Survey and its customers. For example, a city may update Ordnance Survey's data about city roads as the city maintains those roads. OS can then update its Master Map database so that the rest of Britain has current data about that city's roads.*

Master Map is proving to be a success ...

*Fonte IDC

Cultural Background

- SIGMATER: soa based italian e-gov project.
- Region exchanges (cartographic) data with co-operating Provinces/Municipalities and Cadastral agencies
- Topographic-DB as National Core of Regional DBTI

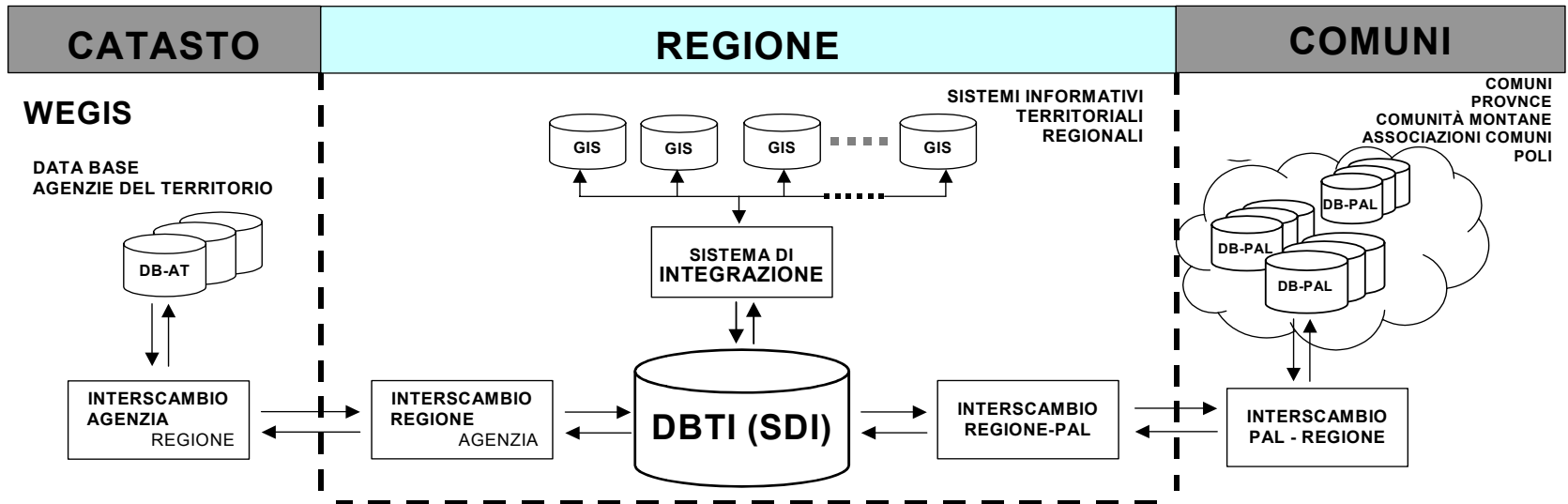

- **WEGIS Project:** cartographic updating process
 - Applications installed on each cadastral agency *manage* LongTransaction Updating Process
 - 100 cadastral agencies provide data for Parcel features Service

Long Transaction Parcels Updating Process

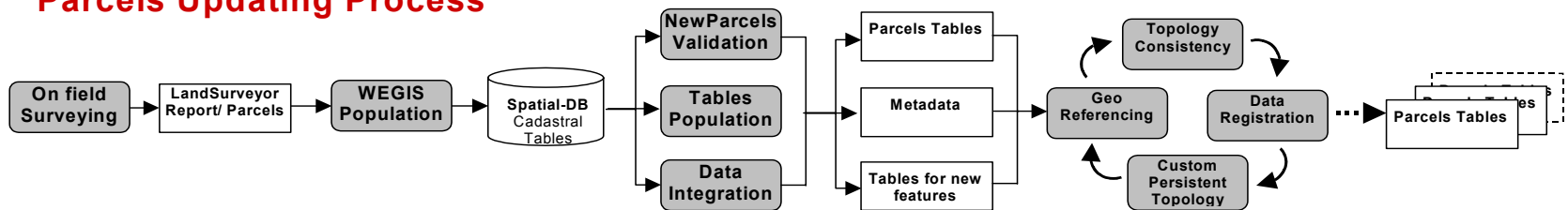

Topographic-DB setup (1)

- SDI topographic features population:
Aree_Verdi, Aree_Unità_Volumetriche and Aree_Stradali
 - Loader tool: DbMAP ASJ or SHP2SDO.EXE
- Geometry Validation and Rectification
 - **SDO_GEOM.VALIDATE_GEOMETRY_WITH_CONTEXT**(geom, 0.01)
 - **SDO_UTIL.RECTIFY_GEOMETRY**(geom, 0.01)
- Topology Relationship Verification
 - `select count(*) from AREE_VERDI a, AREE_STRADALI b where`
SDO_OVERLAPBDYINTERSECT(a.geom,b.geom)='TRUE';
- Geometry Cleansing
 - Interactive tools / Spatial functions

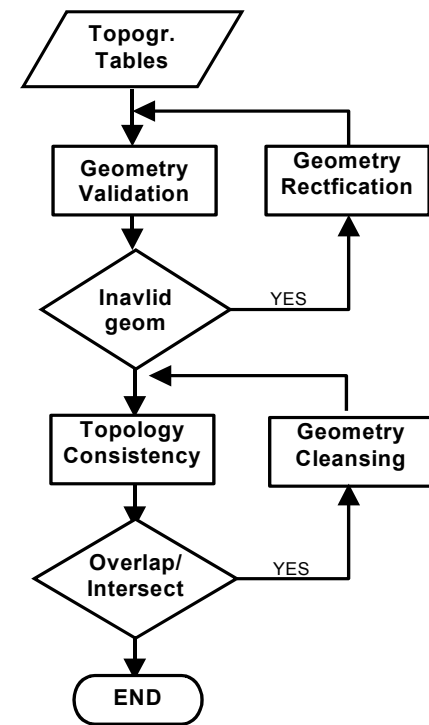

After validation, we observed that topographic feature polygons, provided by Consorzio Comuni Di Bolzano, resulted all geometrically valid, OGC compliant, adjacent (touch) each other and with no areal overlapping.

Topographic-DB setup (2)

Topology Transposition

From **Simple Feature Model**

to

Topology Feature Model

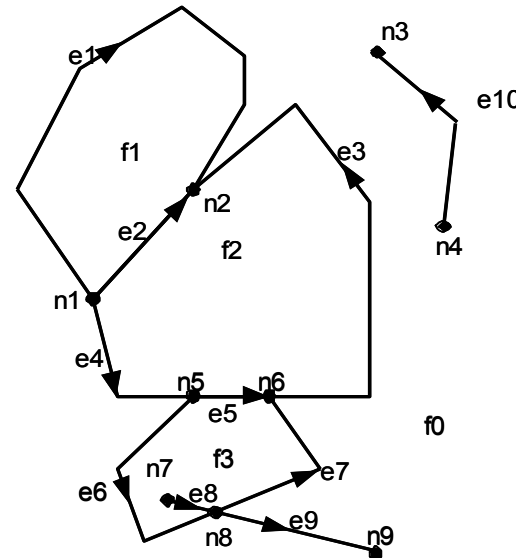
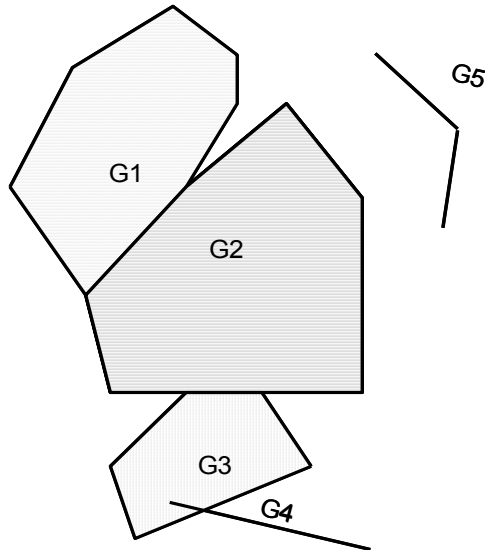

```
Insert into AREE_STRADALI values (stradeRec.id,  
SDO_TOPO_MAP.CREATE_FEATURE  
('T_VANGA','T_AREE_STRADALI','TGEOM', stradeRec.geom));
```

Topographic-DB setup (3)

- Topographic features defined by **SDO_TOPO_GEOMETRY**.
- Cartographic attribute defined by topology attributes:
 - No *edge* redundancy, Persistent relation ...
- Each topographic area represented by a unique topoPrimitive *FACE*
 - Topographic table in a **OneToOne** relationship with TOPO_FACE\$ table

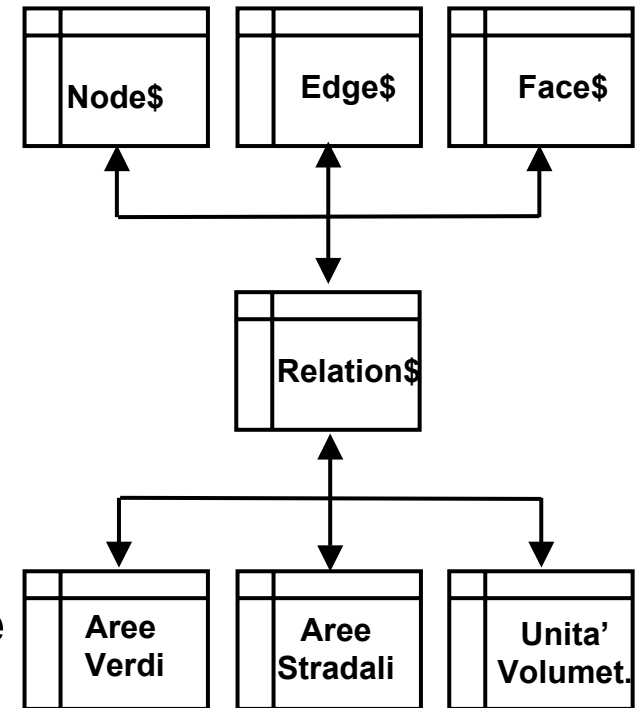

- **Long Transaction Process Workflow**

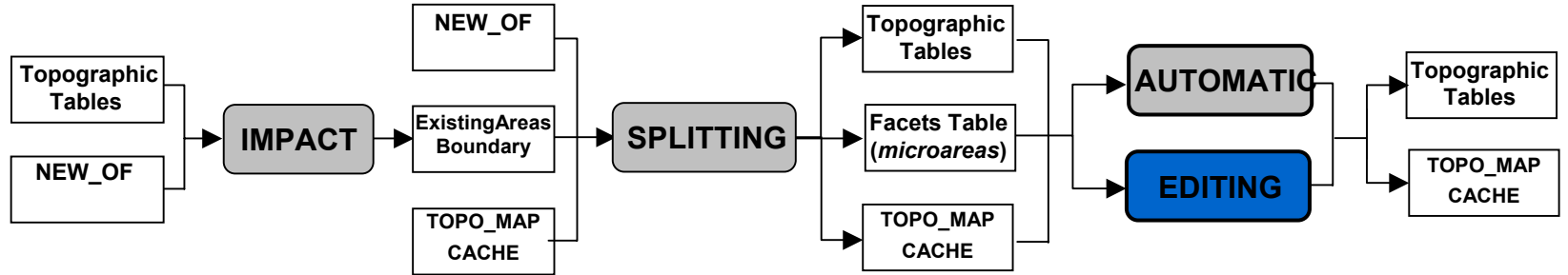

*Impact of newFeatures
With ExistingFeatures*

*Splitting (Intersection) of
the new and existing Features*

*Composition of the
newTopoFeatures
Automatic/ Editing*

*Commit/Transaction
of the newTopoFeatures*

New features IMPACT (2)

- Controls New features topology relationship with existing features

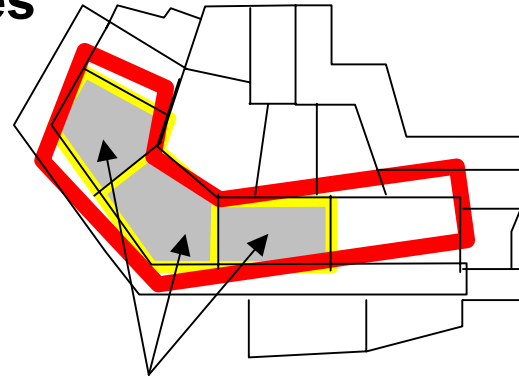
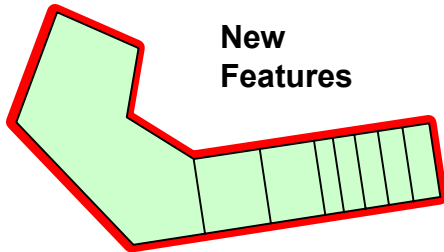

```
select  
SDO_AGGR_UNION(SDOAGGRTYPE(c.geom, 0.1))  
from NEW_OF;
```

Existing Area *coveredBy*
select **SDO_AGGR_UNION**(SDOAGGRTYPE(c.geom, 0.1))
from TopgraphicTable where
SDO_COVEREDBY(geom, **NewFeaturesBoundary**) =
'TRUE';

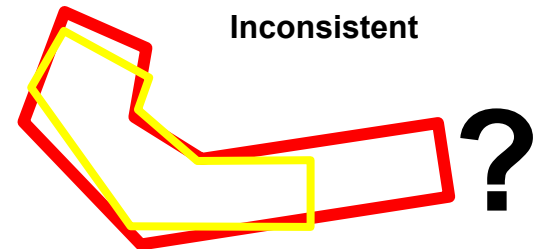
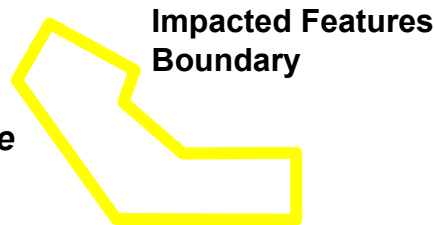
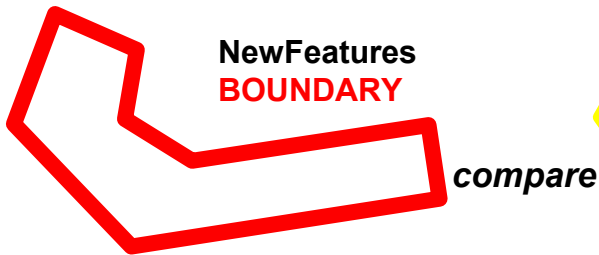

```
Select SDO_GEOM.RELATE  
(NewFeatBoundary, 'determine', ExistingFeatBoundary, 0.1 )  
from TopographicTable;
```

April 2006

Oracle Spatial Users Conference

- Can generate Topology **Consistency** or **NON-Consistency**

UN-Consistency

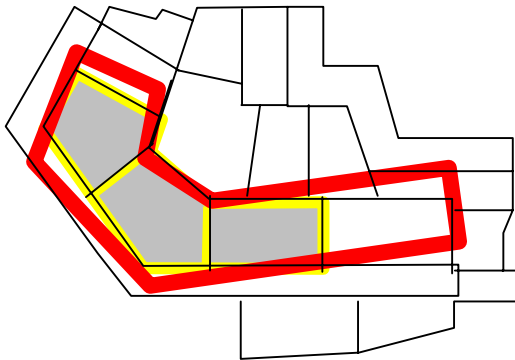

New feature boundaries intersect existing features.
Only **interactive editing** can compose new topographic features.

Consistency

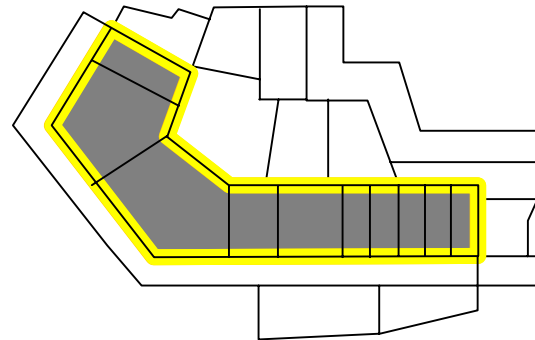

New boundaries contain/cover/touch existing features.
Possible **Automatic** composition of new topographic features.

Splitting (1)

- AREA SPLTTING: through the **ADD_POLYGON_GEOMETRY** of the Topo-API package, the procedure splits both the new and underlying existing features into ex novo generated topoPrimitive face\$: **facets**
- Facets are provided in **Microaree table**: OneToOne relationship with face\$ of TOPO_MAP.
- FaceID, FeatureID, Sdo_Geometry: in this way, sdo_topo_geometry *facets* can be accessed, via sdo_geometry, by those graphical GIS applications – like Abaco DbMAP ASJ - already supporting Oracle Saptial

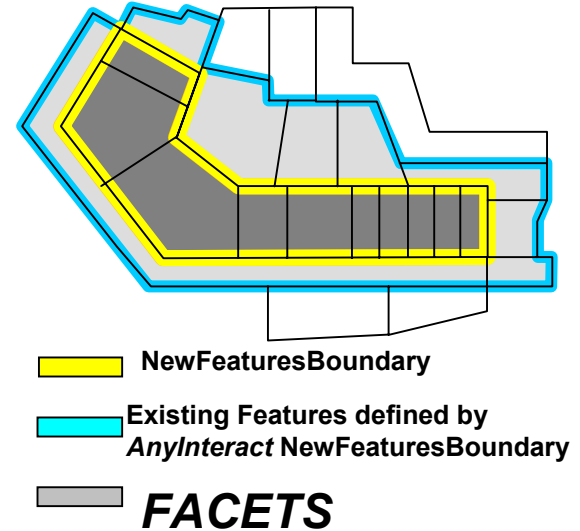

Splitting (2)

April 2006
Oracle Spatial Users Conference

Topographic-DB Global Topology

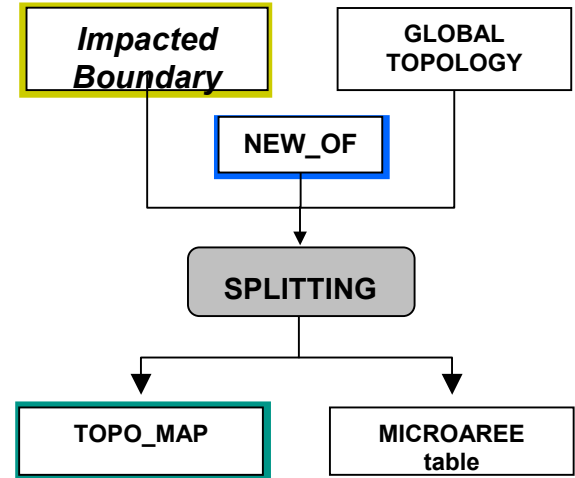
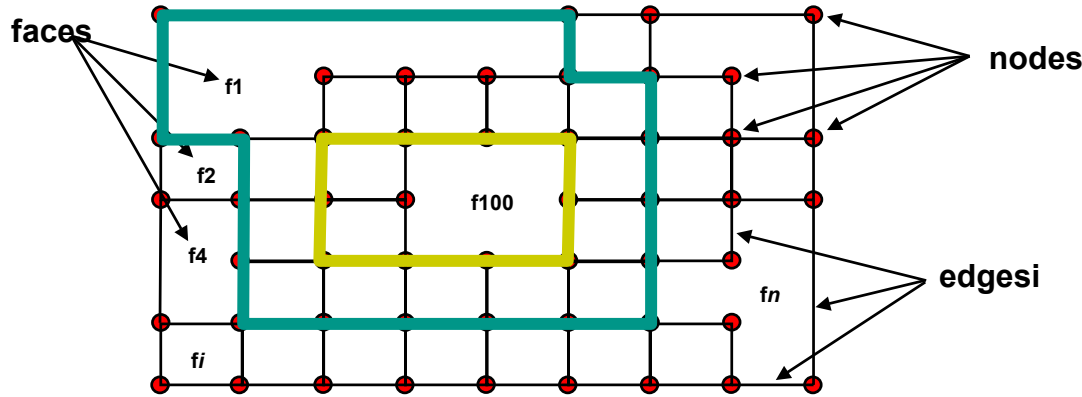

TopoMAP (Client)

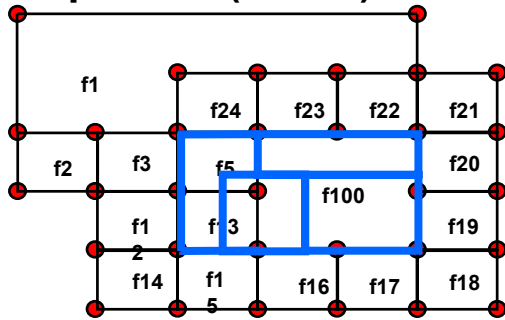

Splitting (clash!)

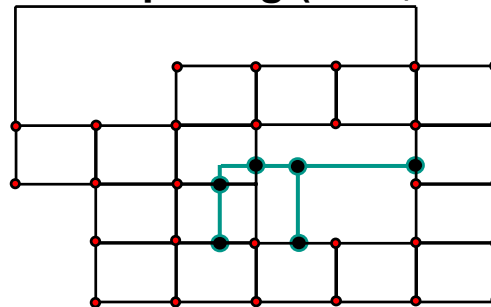

Feature Facets MicroArea



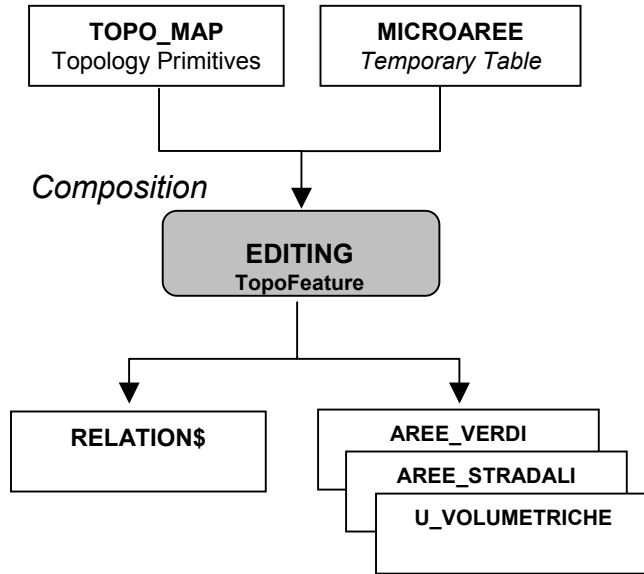

MicroArea

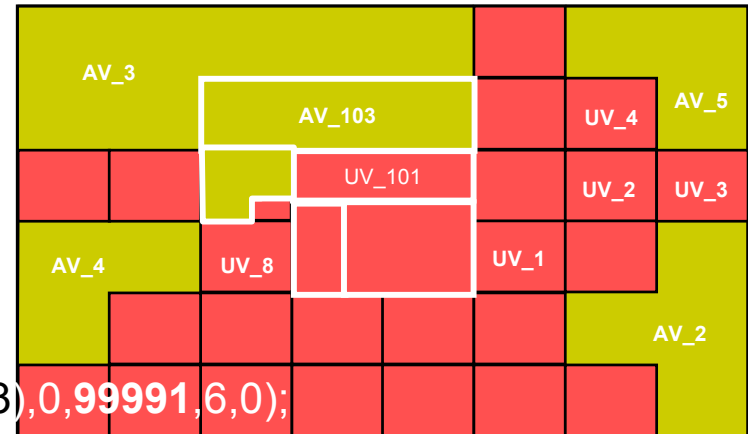
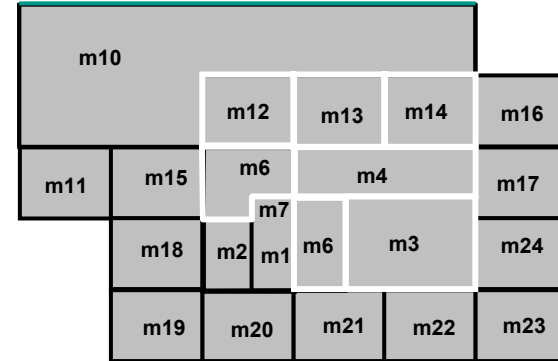

Client based on **Topology_API**:

Create a single facet **TopographicObj**

execute `insertUpdateTopology (1,listface(413),0,99991,6,0);`

Create a multi facet **TopographicObj**

execute `insertUpdateTopology (1,listface(m12, m13, m14),0,AV_102,6,0);`

Cleaning & Commit

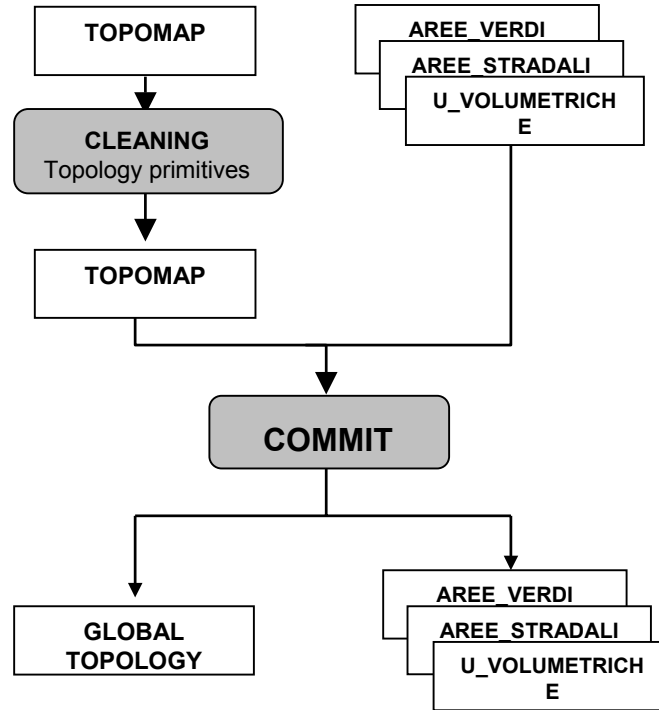

Cleaning of topology primitives:

- Merging multi face primitives defining a single topographicObj
- Deleting edge primitives inside a topographicObj
- **OneToOne** relationship between topographicObj and face primitives

COMMIT for topographicObjs and Topology

Applicative Infrastructure

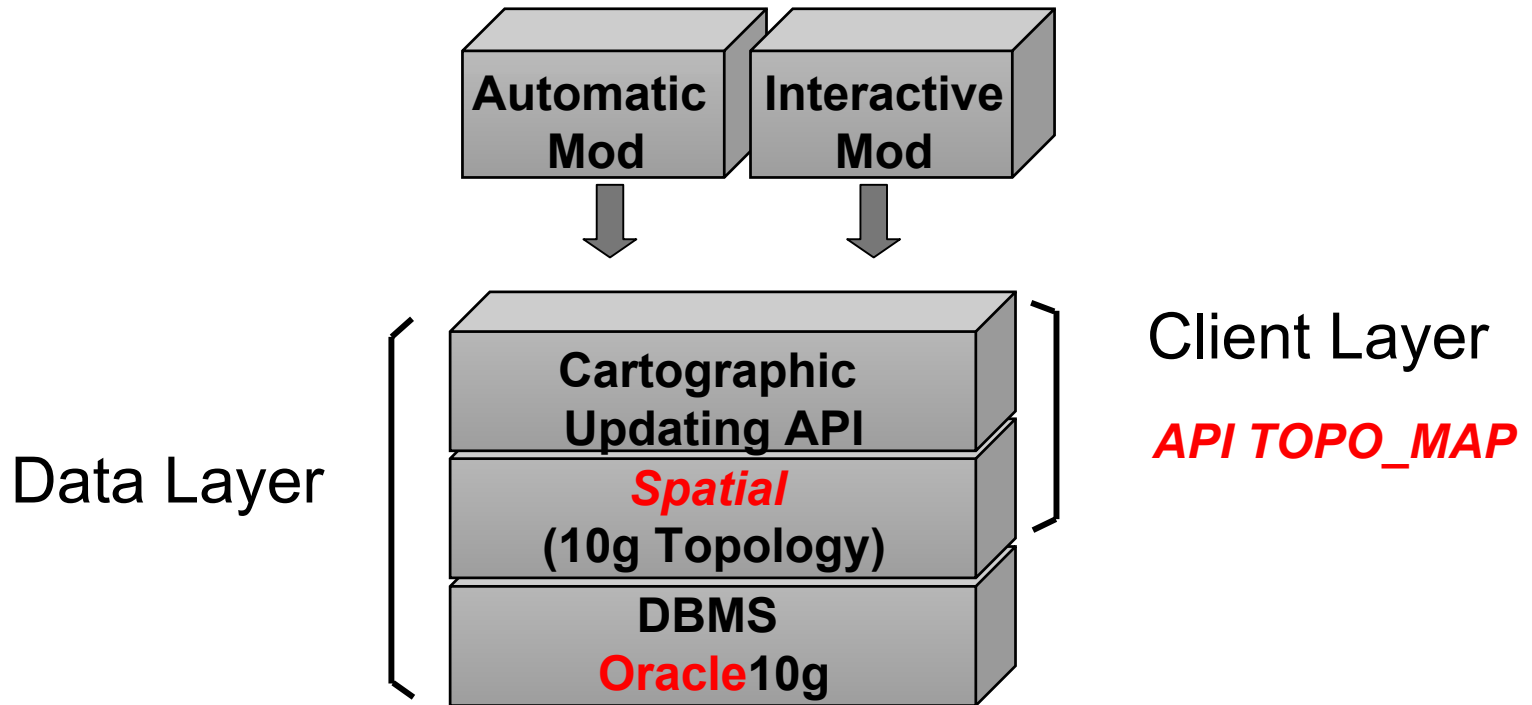

ABACO DbMAP_ASJ

• Interactive Application

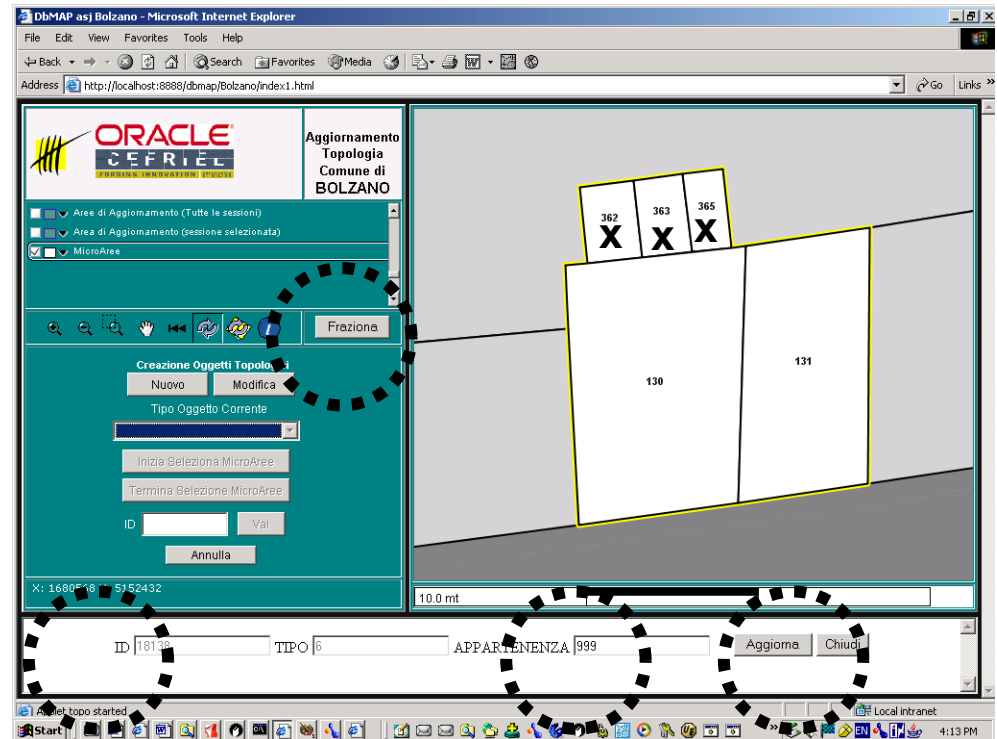
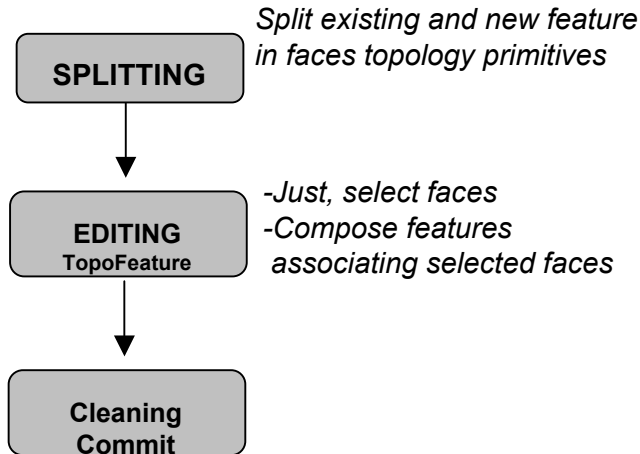

```

SQL> execute fraz1_Frazionamento (sessionID IN NUMBER);
SQL> execute insertUpdateTopology (1,listface(f1,f2 ...fn.....;
  
```

Automatic Updating

- Ascertain if Topological Impact is consistent
- New topographic objects are generated through **SDO_TOPO_MAP.CREATE_FEATURE** spatial topo function
- Impacted objects are deleted
- Cleaning process is invoked
- Commit of new objects
- Usefull for bulk uploading for features impacting *consitently* topology context

**Impact
CONSISTENCY !**

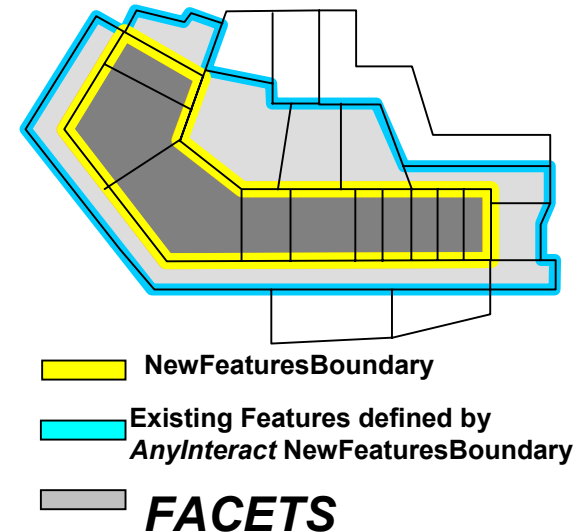

Conclusions

- An Information System is superfluous if data are not updated
 - Specially for GIS: routing, location ...
- Cartographic Data updating process could be defined as *expansive* and *complex*
- Projecting an SDI aimed at *soa* co-operative systems means:
 - Updating **costs** are distributed on satellite systems.
 - Complexity is managed by orchestrating specific *miniprocess* duty simplified.
 - ObjectRelational DBMS, Spatial options and *soa* software infrastructure constitute fundamentals for modern SDI.



If any, please, formulate questions very, very, very, slowly



Oracle Spatial Users Conference

April 27, 2006
Tampa Convention Center
Tampa, Florida, USA



ORACLE

SPATIAL

April 2006

Oracle Spatial Users Conference

Roberto Orsi
Marketing & Sales
Consultant
ABACO srl

r.orsi@abacogroup.com

www.abacogroup.com/eng/

ORACLE

SPATIAL

April 2006

Oracle Spatial Users Conference

DbMAP

Development tools to
build GIS applications

ORACLE

SPATIAL

April 2006

Oracle Spatial Users Conference

Agenda

- DbMAP - ABACO GIS Technology
- Specific to whom / what?
- Applications
- DbMAP - Architecture
- Integrated 2D & 3D Web-GIS
- How easy is it?

DbMAP – GIS Technology

- **DbMAP: Independent, cost-effective and user-friendly platform to build and release GIS and Web-GIS applications based on Oracle Spatial and Locator**
 - **DbMAP ASJ:**
 - Complete and efficient suite of client/server components and applications delivering advanced GIS features;
 - **DbMAP Web 3D:**
 - 3D web visualization of bidimensional spatial data;
 - **DbMAP Pocket:**
 - An efficient and customizable application specifically designed to take advantage of handhelds's mobility.

Specific to whom / what?

- Developers and technicians of those System Integrators and Public Administrations that need to:
 - Build Web-GIS portals, Desktop and Handheld's applications to:
 - Manage and distribute 2D and 3D territorial data;
 - Centralise and manage Spatial Databases;
 - Integrate advanced GIS capability into their own solutions.

April 2006

Oracle Spatial Users Conference

- Multi-platform: Applet components, OCX and Java classes, also open-source, but at the same time independent and royalty-free
- Client: Internet / Intranet, Desktop HTTP client/server and mobile

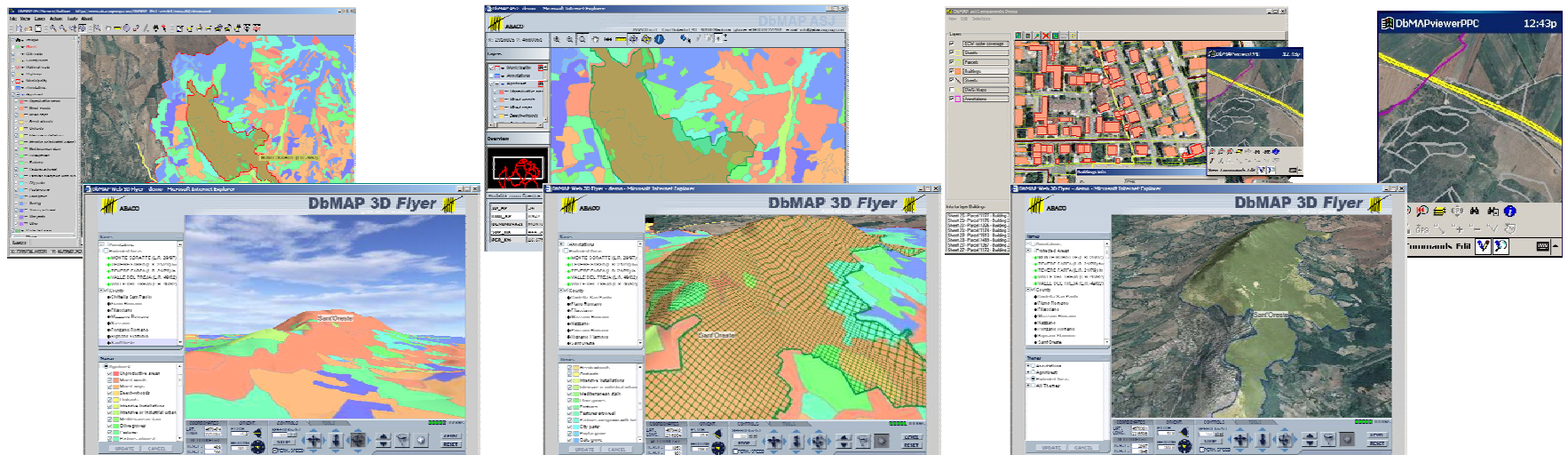

DbMAP – Architecture

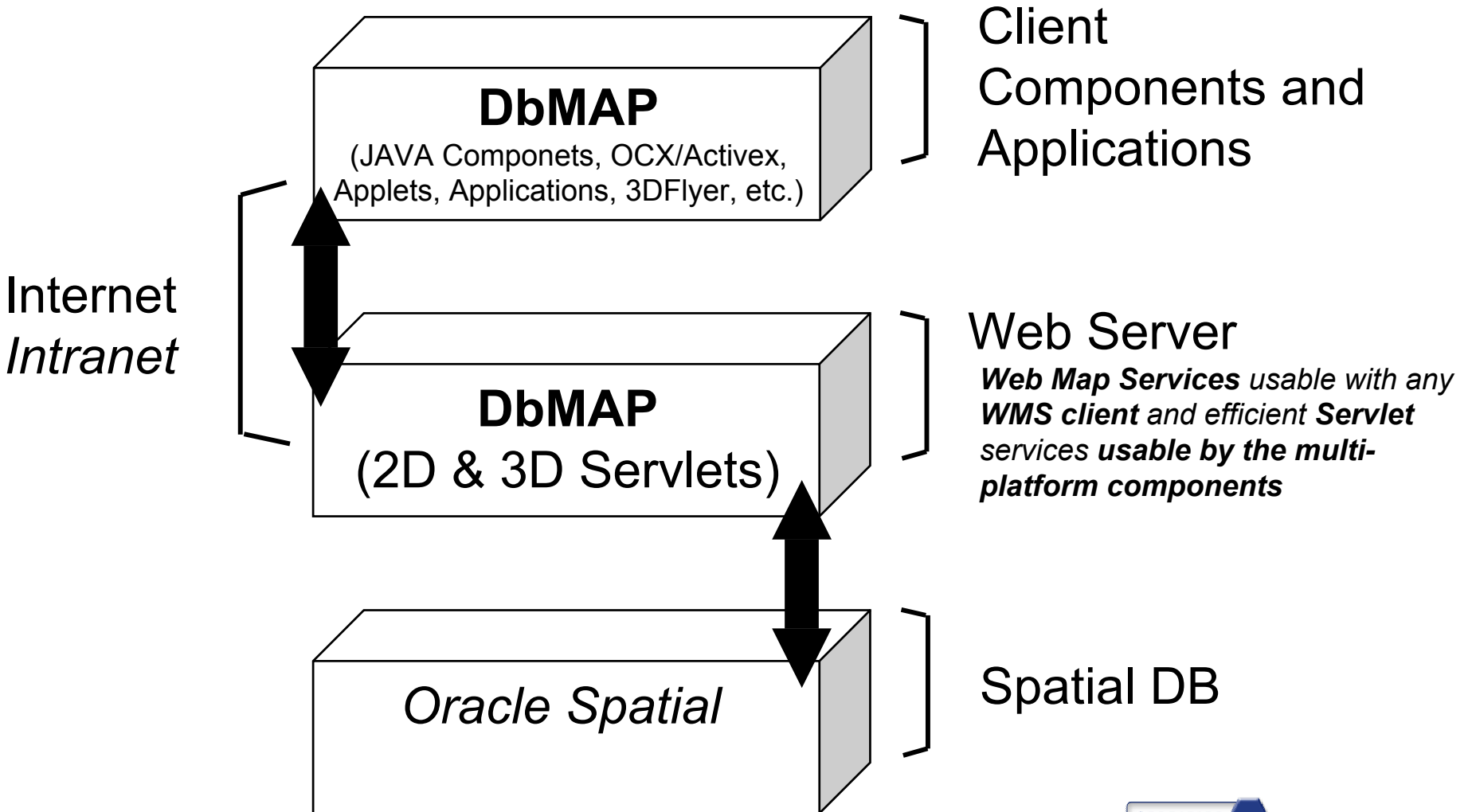

Integrated 2D&3D Web-GIS

April 2006

Oracle Spatial Users Conference

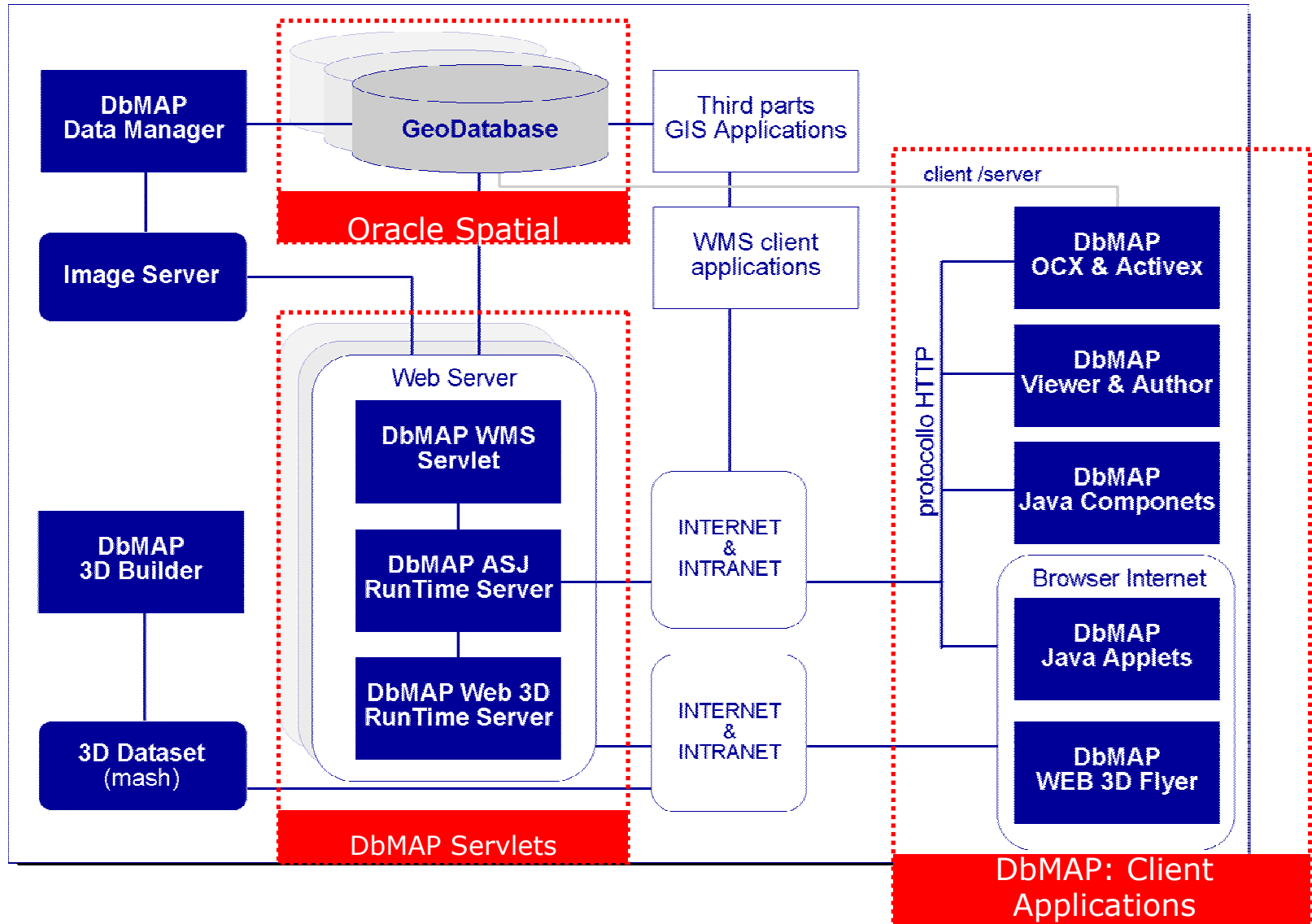

How easy is it?

- Installation and configuration of DbMAP ASJ's servlets;
- Publication of a 2D Web-GIS portal;
- Developers and technicians of those System Integrators and Public Administrations that need:
 1. To use DbMAP Data Manager to import data in the spatial database;
 2. To use DbMAP Viewer & Author to create a GIS project to publish on the web;
 3. To use DbMAP applets to navigate, interrogate and edit geographic data on any internet browser;
- Installation and configuration of DbMAP Web 3D servlets;
- Publication of a 3D Web-GIS portal:
 1. Use of DbMAP 3D Builder to create the 3D dataset;
 2. Design of Web 3D visualization project;
 3. Use of DbMAP Web 3D Flyer to navigate and interrogate in 3D on the Web.

Q & A



Oracle Spatial Users Conference

April 27, 2006
Tampa Convention Center
Tampa, Florida, USA