

StorageTek Enterprise Library Software

Syntax Quick Reference

Version 7.2

ORACLE

Part Number: E48498-01
December 2013

Submit comments about this document to STP_FEEDBACK_US@ORACLE.COM.

Oracle welcomes your comments and suggestions for improving this book. Contact us at STP_FEEDBACK_US@ORACLE.COM. Please include the title, part number, issue date, and revision.

Copyright © 2013, 2012, Oracle and/or its affiliates. All rights reserved.

This software and related documentation are provided under a license agreement containing restrictions on use and disclosure and are protected by intellectual property laws. Except as expressly permitted in your license agreement or allowed by law, you may not use, copy, reproduce, translate, broadcast, modify, license, transmit, distribute, exhibit, perform, publish, or display any part, in any form, or by any means. Reverse engineering, disassembly, or decompilation of this software, unless required by law for interoperability, is prohibited.

The information contained herein is subject to change without notice and is not warranted to be error-free. If you find any errors, please report them to us in writing.

If this is software or related software documentation that is delivered to the U.S. Government or anyone licensing it on behalf of the U.S. Government, the following notice is applicable:

U.S. GOVERNMENT RIGHTS Programs, software, databases, and related documentation and technical data delivered to U.S. Government customers are "commercial computer software" or "commercial technical data" pursuant to the applicable Federal Acquisition Regulation and agency-specific supplemental regulations. As such, the use, duplication, disclosure, modification, and adaptation shall be subject to the restrictions and license terms set forth in the applicable Government contract, and, to the extent applicable by the terms of the Government contract, the additional rights set forth in FAR 52.227-19, Commercial Computer Software License (December 2007). Oracle USA, Inc., 500 Oracle Parkway, Redwood City, CA 94065.

This software or hardware is developed for general use in a variety of information management applications. It is not developed or intended for use in any inherently dangerous applications, including applications which may create a risk of personal injury. If you use this software or hardware in dangerous applications, then you shall be responsible to take all appropriate fail-safe, backup, redundancy, and other measures to ensure the safe use. Oracle Corporation and its affiliates disclaim any liability for any damages caused by use of this software or hardware in dangerous applications.

Oracle is a registered trademark of Oracle Corporation and/or its affiliates. Oracle and Java are registered trademarks of Oracle and/or its affiliates. Other names may be trademarks of their respective owners.

AMD, Opteron, the AMD logo, and the AMD Opteron logo are trademarks or registered trademarks of Advanced Micro Devices. Intel and Intel Xeon are trademarks or registered trademarks of Intel Corporation. All SPARC trademarks are used under license and are trademarks or registered trademarks of SPARC International, Inc. UNIX is a registered trademark licensed through X/Open Company, Ltd.

This software or hardware and documentation may provide access to or information on content, products, and services from third parties. Oracle Corporation and its affiliates are not responsible for and expressly disclaim all warranties of any kind with respect to third-party content, products, and services. Oracle Corporation and its affiliates will not be responsible for any loss, costs, or damages incurred due to your access to or use of third-party content, products, or services.

Contents

Preface	11
Related Documentation	12
Documentation, Support, and Training	12
Additional Information	13
1. SMC Commands and Control Statements	19
ALLOCDef	20
ALLOCJob	21
CMDDef	22
COMMtest	23
Display DRive	24
Display RC	25
Display Volume	25
DRIVemap	26
Help	27
HTTP	28
List	29
LOG	30
METAdata	31
MONitor	32
MOUNTDef	33
MSGDef	34
MSGJob	35
POLicy	36
READ	37

RESYNChronize	37
Route	38
SERVer	39
SIMulate	40
STORMNGR	41
TAPEPlex	42
TCPip	43
TRace	44
TREQDef	45
TAPEREQ Control Statement	46
UEXit	47
UNITAttr	48
USERMsg	49
2. HSC and VTCS Commands and Control Statements	51
ACTIvities	52
ACTMVCgn	52
ARCHive	53
AUDit	54
BACKup	55
CANcel	55
CAPPref	56
CDs	56
CDSData	57
CDSDEF	57
CLEan	58
COMMPath	59
CONFIg	60
CONFIg GLOBAL Statement	61
CONFIg RECLAIM Statement	62
CONFIg VTSS Statement	62
CONFIg RTD Statement	62
CONFIg VTD Statement	62
CONFIg CLUSTER Statement	62

CONFIg CLINK Statement	63
CONFIg HOST Statement	63
CONFIg TAPEPLEX Statement	63
CONSolid	64
DEComp	64
DELETSCR	65
DIRBLD	65
DISMount	66
Display Acs	66
Display ACTive	67
Display ALl	67
Display Cap	68
Display CDS	68
Display CLInk	69
Display CLUster	69
Display CMD	70
Display COMMPath	70
Display CONFIG	71
Display DRives	71
Display DRIVE_INFO	72
Display EXceptns	73
Display LMUPDEF	73
Display LOCKs	74
Display Lsm	74
Display Message	75
Display MGMTDEF	75
Display MIGrate	76
Display MNTD	76
Display MONitor	77
Display MVC	77
Display MVCPool	78
Display OPTion	78
Display PATH	79

Display Queue 79
Display REPlicat 80
Display Requests 80
Display RTD 81
Display SCRatch 81
Display SEN 82
Display SERVER 82
Display SRVlev 83
Display Status 83
Display STORCLas 84
Display STORMNgr 84
Display TASKs 85
Display THReshld 85
Display Volser 86
Display VOLume_Info 86
Display VSCRatch 87
Display VTD 87
Display VTSS 88
Display VTV 88
DRAin 89
DRCHKPT 90
DRMONitr 91
DRTEST CREATE 92
DRTEST PRIMEprd 93
DRTEST RESET 94
DRTEST START 94
DRTEST STOP 95
EEXPORT 96
Eject 97
ENter 98
EXECParm 98
EXPORT 99
FMTLOG 100

IMPORT	101
INITialize	102
INVENTORY	103
LIBGen	103
LMUPDEF	104
LMUPATH Control Statement	104
LOGUTIL	105
LOGUTIL FOR_LOSTMVC Statement	105
LOGUTIL GENAUDIT Statement	106
LOGUTIL LOCATE_VTV	106
LOGUTIL UNDELETE Statement	106
MERGEcds	107
SLSMERGE Control Statement	107
MERGMFST	108
METAdata	109
MGMTDEF	109
MGMTclas Control Statement	110
MIGRSEL Control Statement	110
MIGRVTV Control Statement	111
MVCATTR Control Statement	111
STORclas Control Statement	111
STORLST Control Statement	112
STORSEL Control Statement	112
VTSSLST Control Statement	112
VTSSSEL Control Statement	113
MIGrate	114
Format 1	114
Format 2	114
MNTD	115
MODify	116
Mount	117
MOVE	118
MVCDRain	119

MVCMaint 120
MVCPLRPT 121
MVCRpt 121
OFFload LOGFILE 122
OPTION TITLE Control Statement 122
OPTion 123
RECall 124
RECLaim 125
RECONcil 126
RECOVer 126
RELease 127
REPLaceall 127
REStore 128
RTV Utility 128
SCRAtch 129
SCREdist 129
SCRPT 130
SENter 130
SET CLNPRFX 131
SET COMPREFX 131
SET DRVHOST 132
SET EJCTPAS 132
SET FREEZE 133
SET HOSTID 133
SET HSCLEVel 134
SET LOGFILE 134
SET MAJNAME 135
SET MIGOPT 135
SET NEWHOST 136
SET RMM 136
SET SCRLABL 137
SET SLIDRIVS 137
SET SLISTATN 138

SET SMF	138
SET TAPEPlex	139
SET TCHNIQE	139
SET VAULT	140
SET VAULTVOL	140
SET VOLPARM	141
POOLPARM Control Statement	142
VOLPARM Control Statement	143
SRVlev	143
STOPMN	144
SWitch	144
TRace	145
TRACELKP	145
UEXIT	146
UNSCratch	146
UNSElect	147
Vary	148
View	149
VOLPCONV	150
VOLRpt	151
VTVMaint	152
VTVRPt BASIC	153
VTVRPt COPIES	153
VVAUDIT	154
Warn	154

Preface

Oracle's StorageTek Enterprise Library Software (ELS) is a solution consisting of the following base software:

- Oracle's StorageTek Storage Management Component (SMC)
(includes the product formerly known as StorageTek HTTP Server)
- Oracle's StorageTek Host Software Component (HSC)
- Oracle's StorageTek Virtual Tape Control Software (VTCS)
- Oracle's StorageTek Concurrent Disaster Recovery Test (CDRT)

This publication provides syntax for commands, control statements, and utilities provided by ELS. It is intended for storage administrators, system programmers and operators responsible for configuring and maintaining ELS.

To perform the tasks described in this publication, you should already understand the following:

- MSP/EX operating system
- JES
- Enterprise Library Software (ELS)

Related Documentation

StorageTek Enterprise Library Software (ELS)

- *Introducing ELS*
- *Installing ELS*
- *ELS Syntax Quick Reference*
- *ELS Messages and Codes*
- *ELS Programming Reference*
- *ELS Legacy Interfaces Reference*
- *Configuring HSC and VTCS*
- *Managing HSC and VTCS*
- *Configuring and Managing SMC*
- *ELS Disaster Recovery and Offsite Data Management Guide*

Documentation, Support, and Training

Function	URL
Oracle Home	http://oracle.com
Documentation	http://oracle.com/technetwork/indexes/documentation/index.html
Support	http://www.oracle.com/us/support/044752.html
Training	http://www.oracle.com/us/education/selectcountry-new-079003.html

Additional Information

Conventions for Reader Usability

Typographic

Some JCL examples in this guide include *italic* type. Italic type is used to indicate a variable. You must substitute an actual value for these variables.

The use of mixed upper and lower case characters for commands, control statements, and parameters indicates that lower case letters may be omitted to form abbreviations. For example, you may simply enter POL when executing the POLicy command.

Syntax Flow Diagrams

Syntax flow diagramming conventions include the following:

Flow Lines

Syntax diagrams consist of a horizontal base line, horizontal and vertical branch lines, and the text for a command, control statement, macro, or utility. Diagrams are read left to right, and top to bottom. Arrows indicate flow and direction.

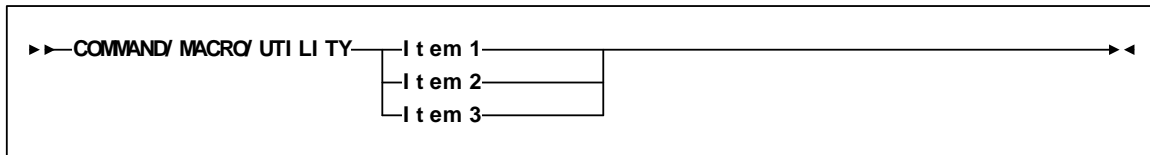

Single Required Choice

Branch lines (without repeat arrows) indicate that a single choice must be made. If one of the items to choose from is positioned on the baseline of the diagram, one item must be selected.

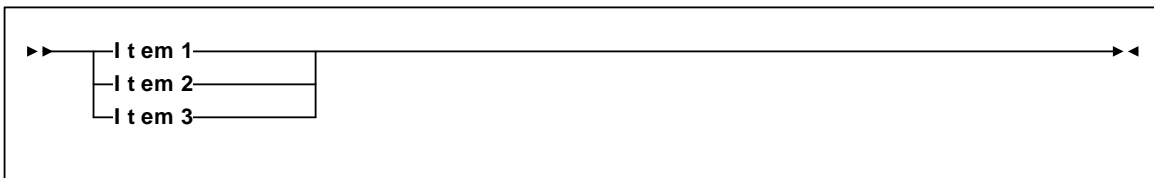

Single Optional Choice

If the first item is positioned on the line below the baseline, one item may be optionally selected.

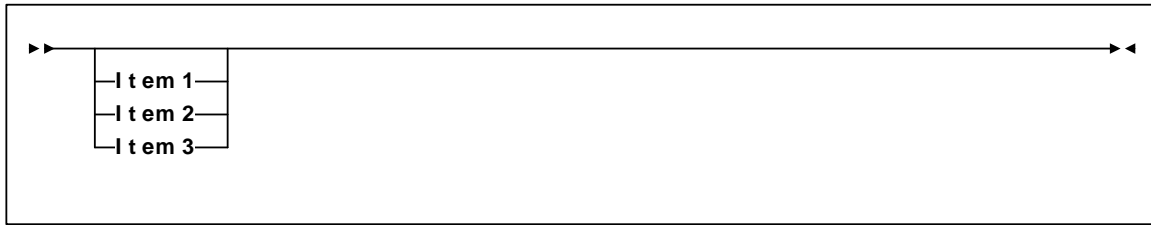

Defaults

Default values and parameters appear above the baseline.

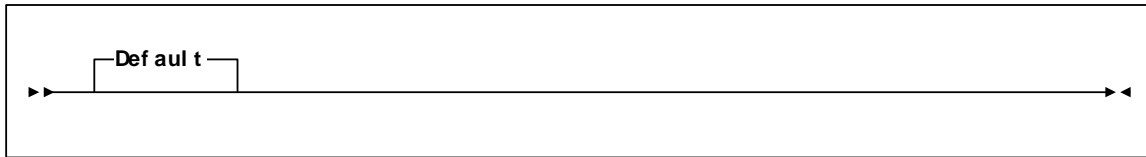

Some keyword parameters provide a choice of values in a stack. When the stack contains a default value, the keyword and the value choices are placed below the baseline to indicate that they are optional, and the default value appears above the keyword line.

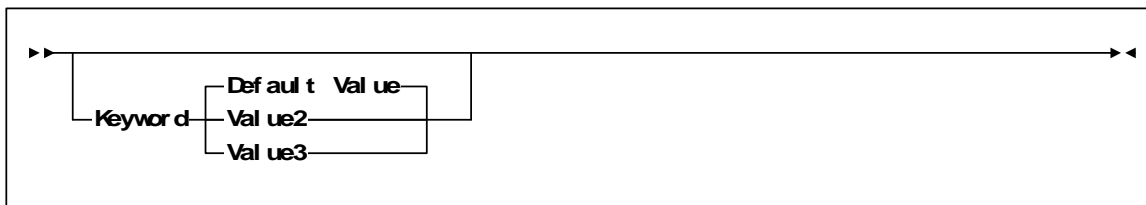

Repeat Symbol

A repeat symbol indicates that more than one choice can be made or that a single choice can be made more than once. The following example indicates that a comma is required as the repeat delimiter.

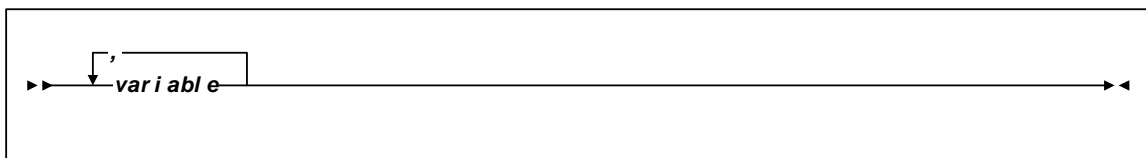

Keywords

All command keywords are shown in all upper case or in mixed case. When commands are not case sensitive, mixed case implies that the lowercase letters may be omitted to form an abbreviation.

Variables

Italic type is used to indicate a variable.

Alternatives

A bar (|) is used to separate alternative parameter values.

Optional

Brackets [] are used to indicate that a command parameter is optional.

Delimiters

If a comma (,), a semicolon (;), or other delimiter is shown with an element of the syntax diagram, it must be entered as part of the statement.

Ranges

An inclusive range is indicated by a pair of elements of the same length and data type, joined by a dash. The first element must be strictly less than the second element.

A hexadecimal range consists of a pair of hexadecimal numbers (for example, 0A2-0AD, or 000-0FC).

A decimal range consists of a pair of decimal numbers (i.e., 1-9, or 010-094). Leading zeros are not required. The decimal portion is referred to as an incremental range. The character positions of the incremental portion of both range elements must match, and the non incremental characters of the first element must be identical to those of the second element.

A numeric VOLSER range (*vol-range*) consists of a pair of VOLSER elements containing a decimal numeric portion of 1 to 6 digits (for example, ABC012-ABC025, or X123CB-X277CB). The decimal portion is referred to as an incremental range. The following additional restrictions apply:

- The character positions of the incremental portion of both range elements must match.
- The non incremental characters of the first element must be identical to those of the second element.
- You cannot increment two portions of a range element. If 111AAA is the first element, you cannot specify 112AAB for the second element.

- If a VOLSER range contains more than one decimal portion, any portion is valid as the incremental range. For example:

A00B00 the largest range that can be specified is A00B00 through A99B99.
A0B0CC the largest range that can be specified is A0B0CC through A9B9CC.
000XXX the largest range that can be specified is 000XXX through 999XXX.

An alphabetic VOLSER range (*vol-range*) consists of a pair of VOLSER elements containing an incremental portion of 1 to 6 characters (for example, 000AAA-000ZZZ, or 9AAA55-9ZZZ55). This portion is referred to as an incremental range. The following additional restrictions apply:

- The character positions of the incremental portion of both range elements must match.
- The non incremental characters of the first element must be identical to those of the second element.
- You cannot increment two portions of a range element. If 111AAA is the first element, you cannot specify 112AAB for the second element.
- The alphabetic portion of the VOLSER range is defined as being from character A to Z. To increment multi-character sequences, each character increments to Z. For instance, ACZ is part of the AAA-AMM range. Examples are:

A00A0-A99A0 increments VOLSERs A00A0 through A09A0, then A10A0 through A99A0.
9AA9A-9ZZ9A increments VOLSERs 9AA9A through 9AZ9A, then 9BA9A through 9ZZ9A.
111AAA-111ZZZ increments VOLSERs 111AAA through 111AAZ, then 111ABA through 111ZZZ
999AM8-999CM8 increments VOLSERs 999AM8 through 999AZ8, then 999BA8 through 999CM8
A3BZZ9-A3CDE9 increments VOLSERs A3BZZ9 through A3CAA9, then A3CAB9 through A3CDE9
AAAAAA-AAACCC increments VOLSERs AAAAAA through AAAAAZ, then AAAABA through AAACCC
CCNNN-DDDNNN increments VOLSERs CCNNN through CCCNNZ, then CCCNOA through DDDNNN *

* **Caution:** This is a very large range.

The number of volumes in an alphabetic VOLSER range depends on the number of elements in the incrementing portion of the VOLSER range. For an A to Z range in each character position, the number of volumes can be calculated by 26 to the power of the number of positions that are being incremented.

A-Z	26^1	26
AA-ZZ	26^2	676
AAA-ZZZ	26^3	17,576
AAAA-ZZZZ	26^4	456,976
AAAAA-ZZZZZ	26^5	11,881,376
AAAAAA-ZZZZZZ	26^6	308,915,776

Lists

A list consists of one or more elements. If more than one element is specified, the elements must be separated by a comma or a blank space, and the entire list must be enclosed in parentheses.

Blanks

Keyword parameters and values may be separated by any number of blanks.

Control Statements

The standard syntax conventions for control statements are as follows:

- The only valid control statement information area is from column 1 to column 72. Columns 73-80 are ignored.
- Parameters may be separated by one or more blanks or a comma.
- A value is associated with a parameter by an equal (=) sign or by enclosing the value in parentheses, and concatenating it immediately after the parameter.
- Case (upper or lower) is ignored in actual control statements.
- Continuations are supported by including a plus (+) sign at the end of the line to be continued. A control statement is terminated if the statement is not continued.
- /* and */ can be used to enclose comments in the job stream. Comments can be continued over multiple lines, but cannot be nested.

PARMLIB members **must** include a /*...*/ comment as the **first** control statement. Otherwise, the old format is assumed. Comments in the old format must begin with an asterisk (*) in column 1.

For definition data sets (e.g., VOLATTRs, UNITATTRs and TAPEREQs), comments **must** be in the new format (/*...*/).

- Asterisk (*) comments are **not** allowed.
- A /*...*/ comment in the first line is **not** required.
- The maximum length for a control statement is 1024 characters.

SMC Commands and Control Statements

This chapter contains syntax for SMC commands and control statements. Interface and subsystem requirement information is included with each command.

Control statements that are loaded by an operator command are described along with that command.

Note – For detailed information about the commands and control statements included in this publication, and the interfaces used to issue them, refer to the *ELS Command, Control Statement, and Utility Reference*.

ALLOCDef

Interfaces:

Console, utility, or SMCCMDS/SMCPARMS data set
 UUI: Yes (No XML/CSV output)

Subsystem Requirements:

Active SMC required, or may be input to the SMCUSIM utility

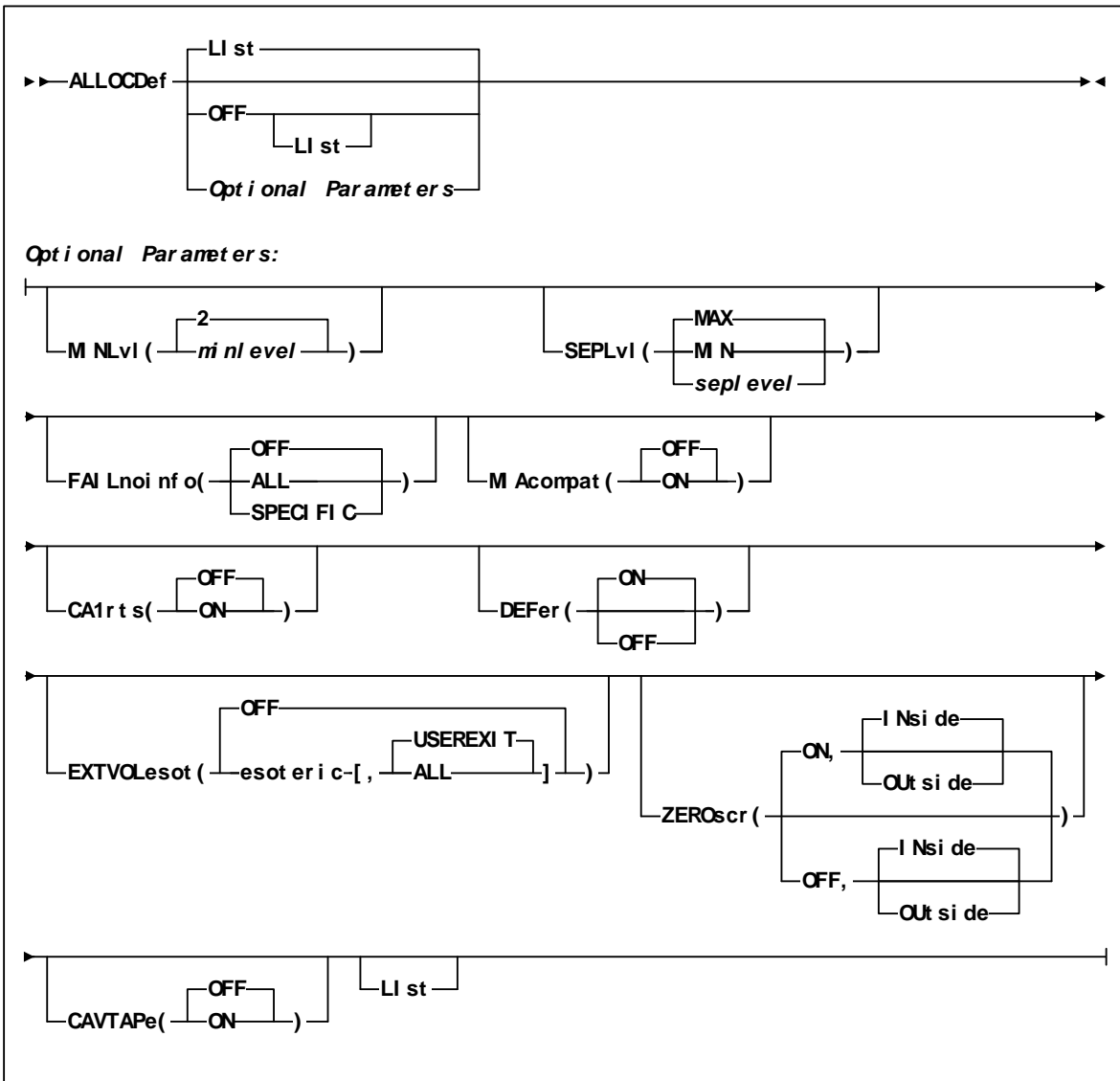

ALLOCJob

Interfaces:

Console, utility, or SMCCMDS/SMCPARMS data set
 UUI: Yes (No XML/CSV output)

Subsystem Requirements:

Active SMC required, or may be input to the SMCUSIM utility

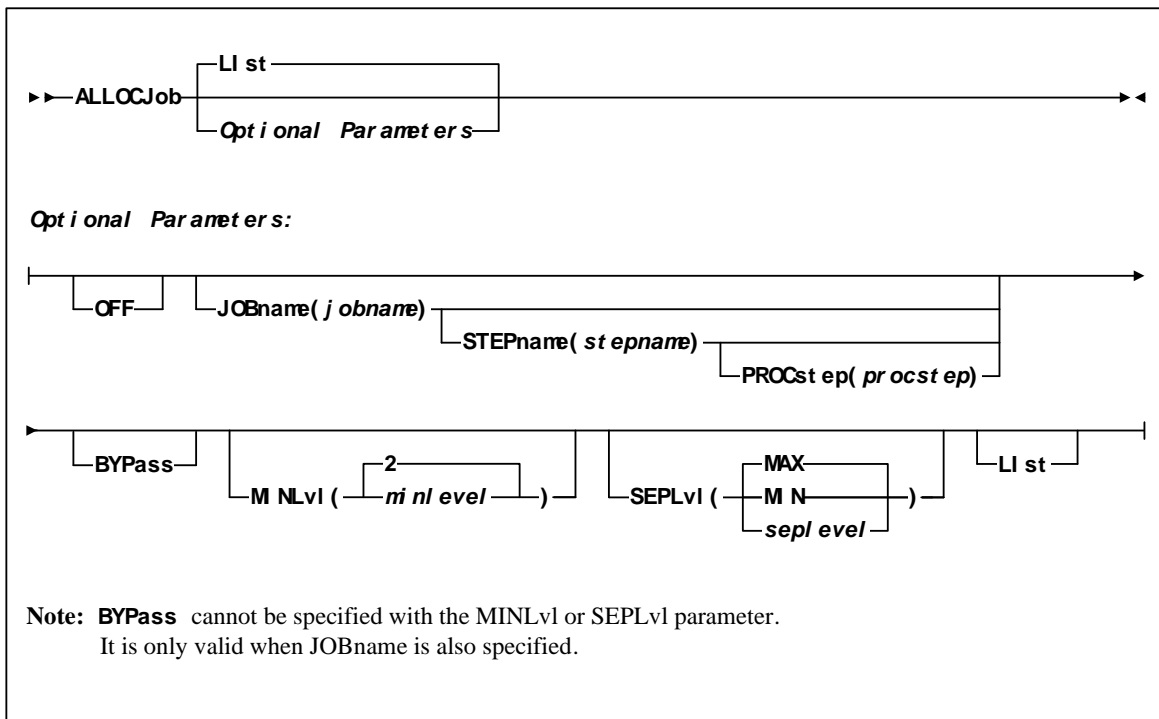

CMDDef

Interfaces:

Console, utility, or SMCPARMS data set
UII: Yes (No XML/CSV output)

Subsystem Requirements:

Active SMC required

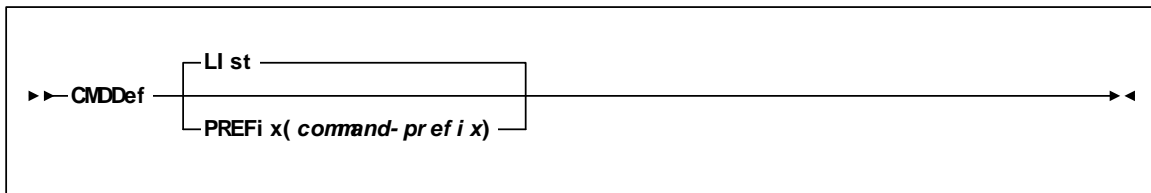

COMMtest

Interfaces:

Console, utility, or SMCCMDS/SMCPARMS data set
UII: Yes (No XML/CSV output)

Subsystem Requirements:

Active SMC required, or may be input to the SMCUSIM utility

Note – Only HSC TapePlexes or VLEs are eligible for the COMMtest command.

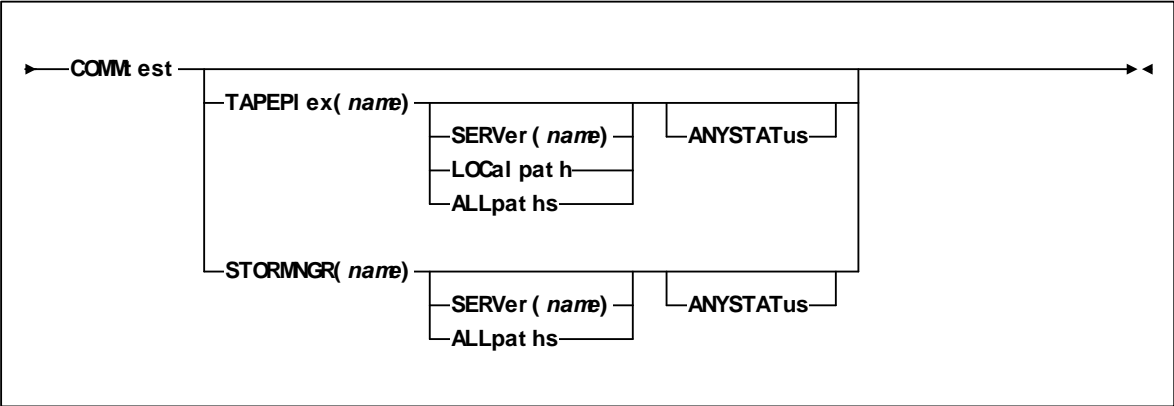

Display DRIve

Interfaces:

Console, utility, or SMCCMDS/SMCPARMS data set
 UUI: Yes (No XML/CSV output)

Subsystem Requirements:

Active SMC required, or may be input to the SMCUSIM utility

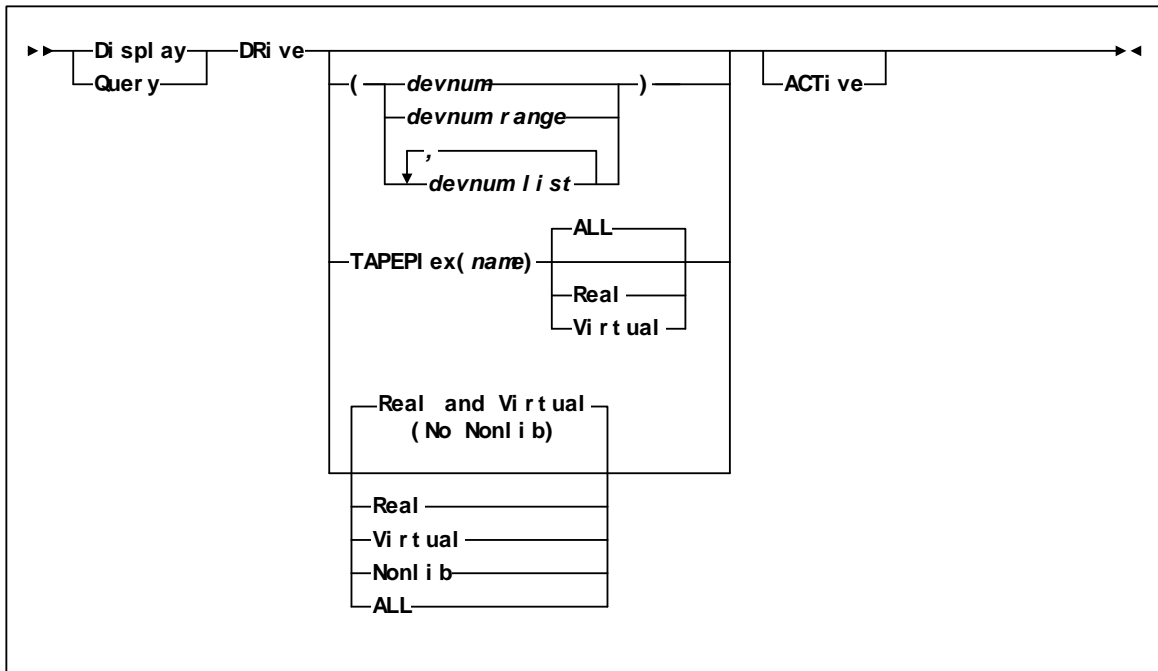

Display POLicy

Interfaces:

Console, utility, or SMCCMDS/SMCPARMS data set
 UUI: Yes (supports XML and CSV)

Subsystem Requirements:

Active SMC required, or may be input to the SMCUSIM utility

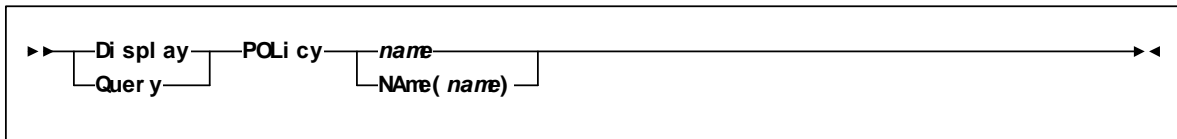

Display RC

Interfaces:

Console, utility, or SMCCMDS/SMCPARMS data set
 UUI: Yes (supports XML and CSV)

Subsystem Requirements:

Active SMC required, or may be input to the SMCUSIM utility

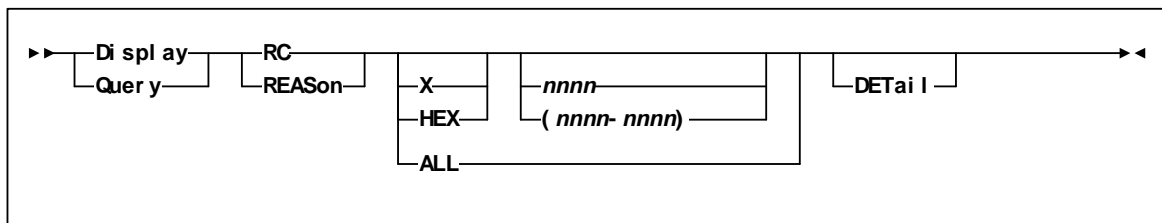

Display SMC

Interfaces:

Console, utility, or SMCCMDS/SMCPARMS data set
UII: Yes (supports XML and CSV)

Subsystem Requirements:

Active SMC required, or may be input to the SMCUSIM utility

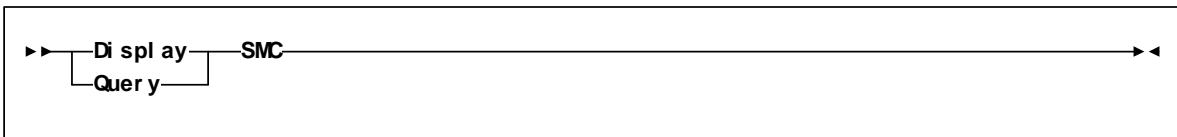

Display STORMNGR

Interfaces:

Console, utility, or SMCCMDS/SMCPARMS data set
UII: Yes (supports XML and CSV)

Subsystem Requirements:

Active SMC required, or may be input to the SMCUSIM utility

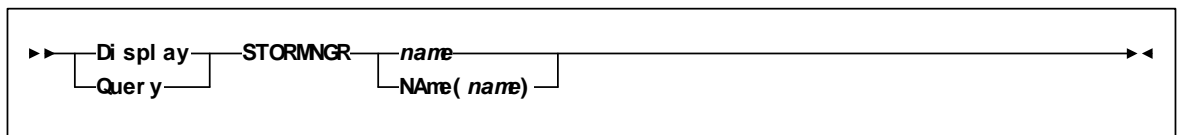

Display TAPEPlex

Interfaces:

Console, utility, or SMCCMDS/SMCPARMS data set
 UUI: Yes (supports XML and CSV)

Subsystem Requirements:

Active SMC required, or may be input to the SMCUSIM utility



Display Volume

Interfaces:

Console, utility, or SMCCMDS/SMCPARMS data set
 UUI: Yes (No XML/CSV output)

Subsystem Requirements:

Active SMC required, or may be input to the SMCUSIM utility

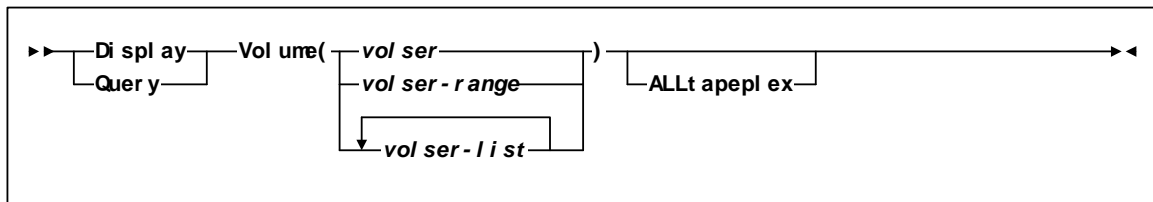

DRIVemap

Interfaces:

Console, utility, or SMCCMDS/SMCPARMS data set
 UUI: Yes (No XML/CSV output)

Subsystem Requirements:

Active SMC required, or may be input to the SMCUSIM utility

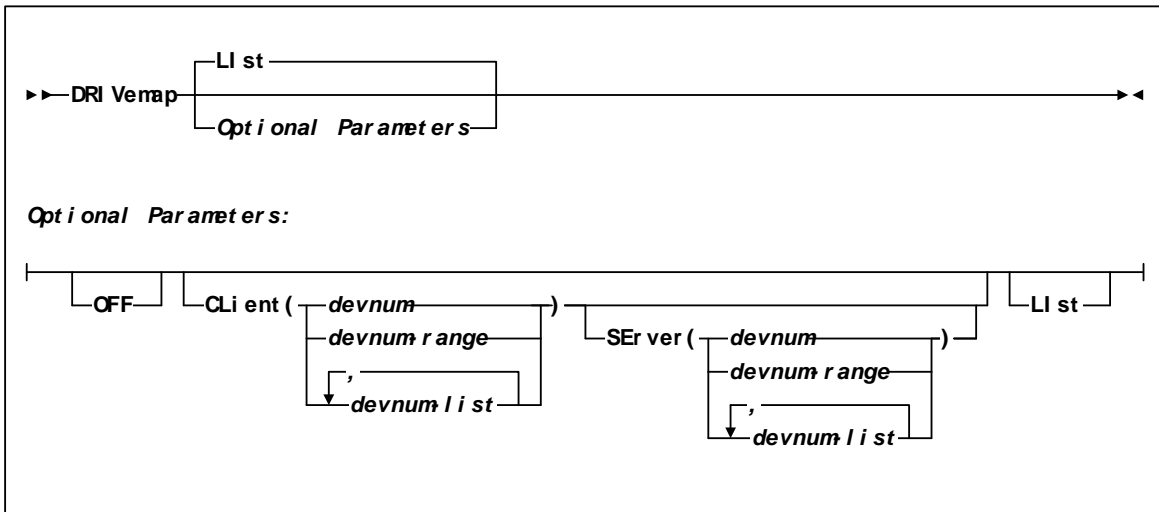

Help

Interfaces:

Console, utility, or SMCCMDS/SMCPARMS data set
UII: Yes (No XML/CSV output)

Subsystem Requirements:

Active SMC required, or may be input to the SMCUSIM utility

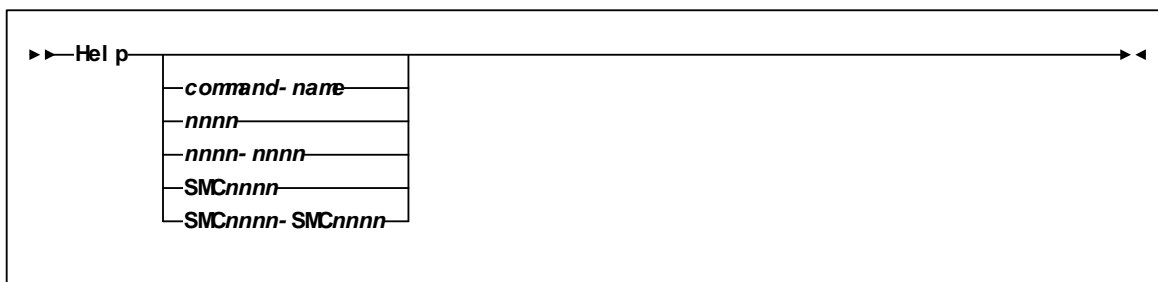

HTTP

Interfaces:

Console, utility, or SMCCMDS/SMCPARMS data set
UUI: Yes (No XML/CSV output)

Subsystem Requirements:

Active SMC required

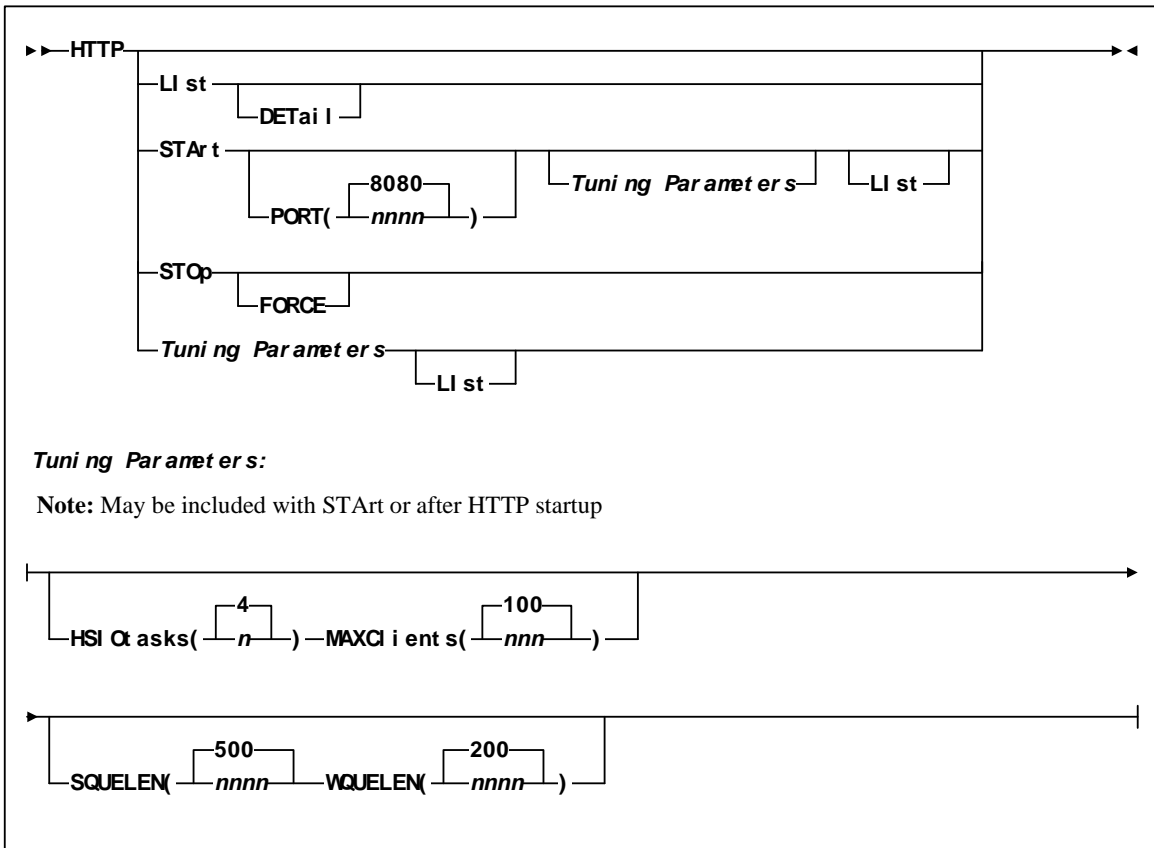

List

Interfaces:

Console, utility, or SMCCMDS/SMCPARMS data set
 UUI: Yes (No XML/CSV output)

Subsystem Requirements:

Active SMC required, or may be input to the SMCUSIM utility

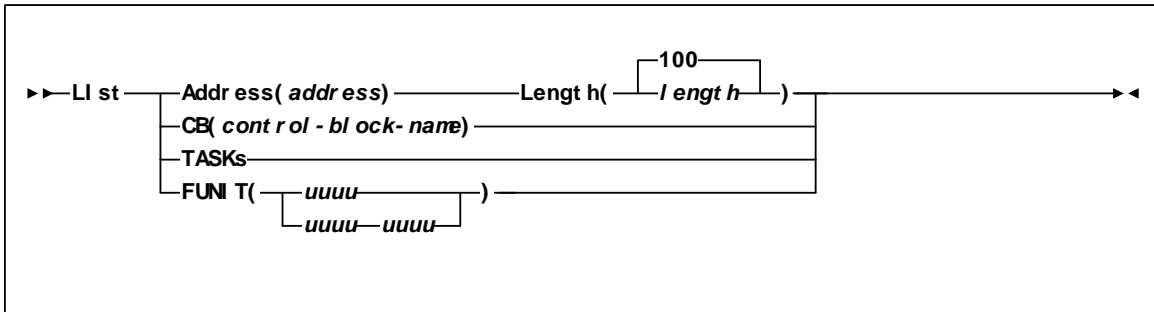

LOG

Interfaces:

Console, utility, or SMCCMDS/SMCPARMS data set
UUI: Yes (No XML/CSV output)

Subsystem Requirements:

Active SMC required

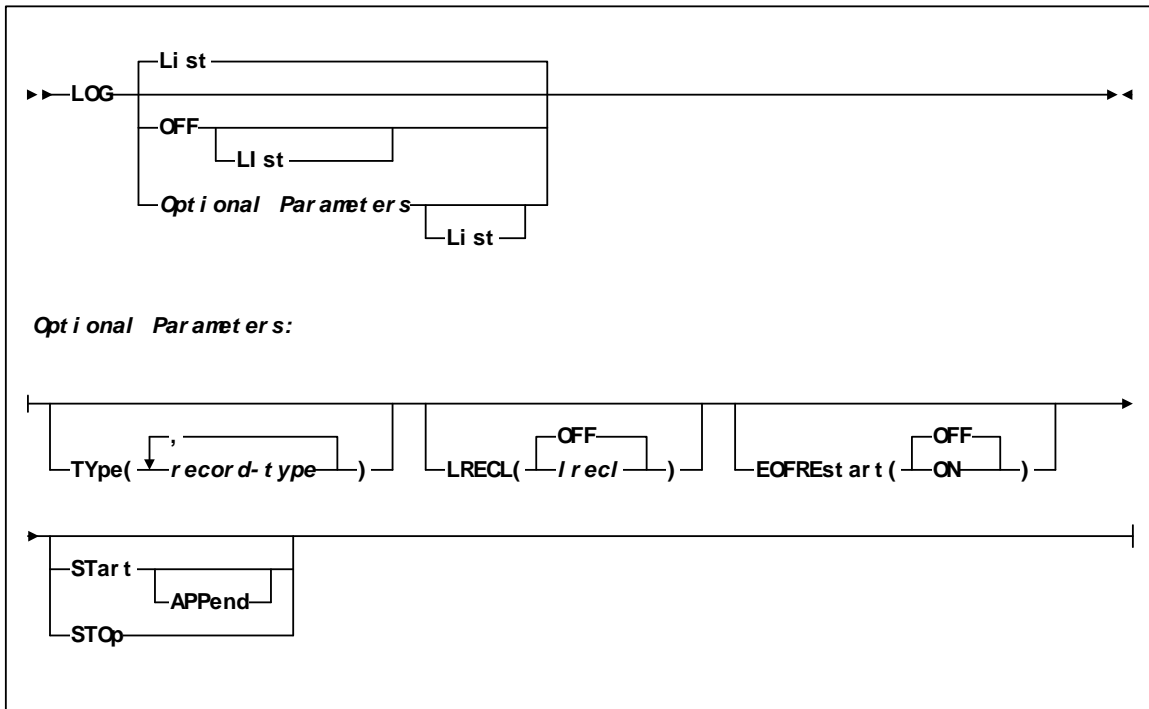

METAdata

Interfaces:

Utility only
UII: Yes

Subsystem Requirements:

Active SMC required

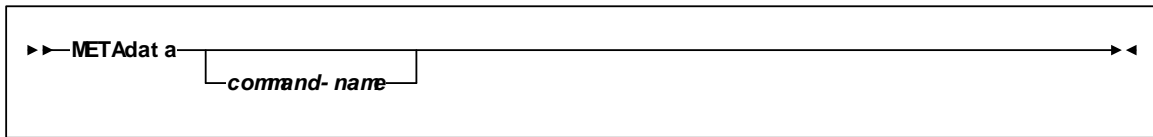

MONitor

Interfaces:

Console, utility, or SMCCMDS/SMCPARMS data set
UUI: Yes (No XML/CSV output)

Subsystem Requirements:

- Active SMC required
- Cannot be input to the SMCUSIM utility

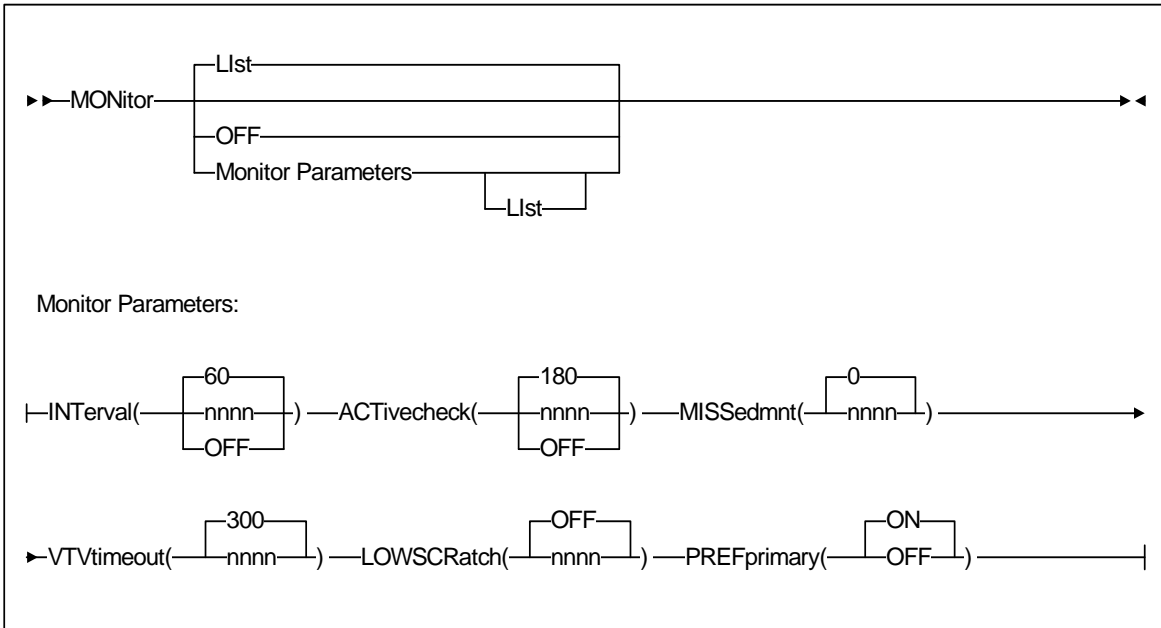

MOUNTDef

Interfaces:

Console, utility, or SMCCMDS/SMCPARMS data set
 UUI: Yes (No XML/CSV output)

Subsystem Requirements:

Active SMC required, or may be input to the SMCUSIM utility

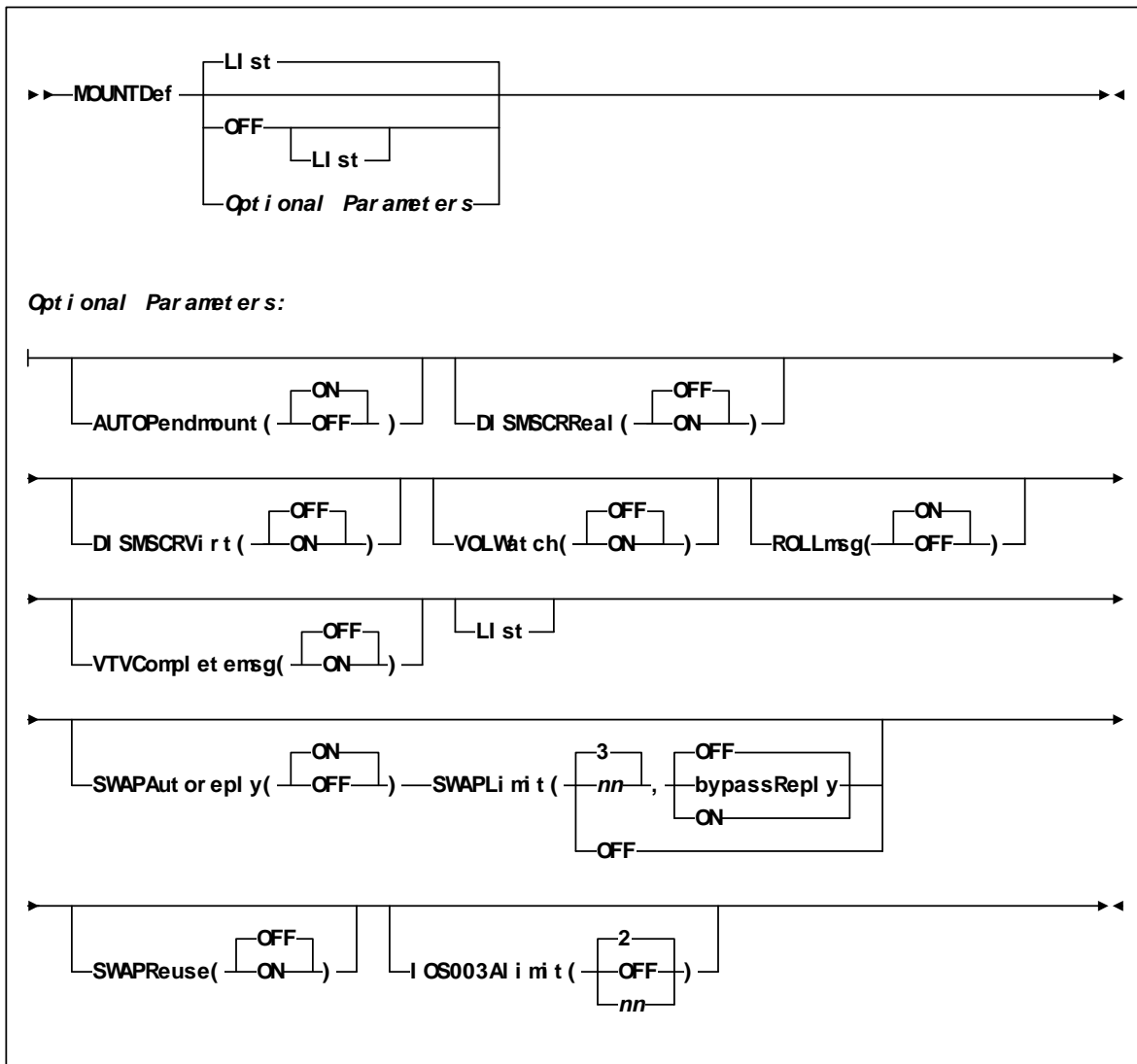

MSGDef

Interfaces:

Console, utility, or SMCCMDS/SMCPARMS data set
 UUI: Yes (No XML/CSV output)

Subsystem Requirements:

Active SMC required, or may be input to the SMCUSIM utility

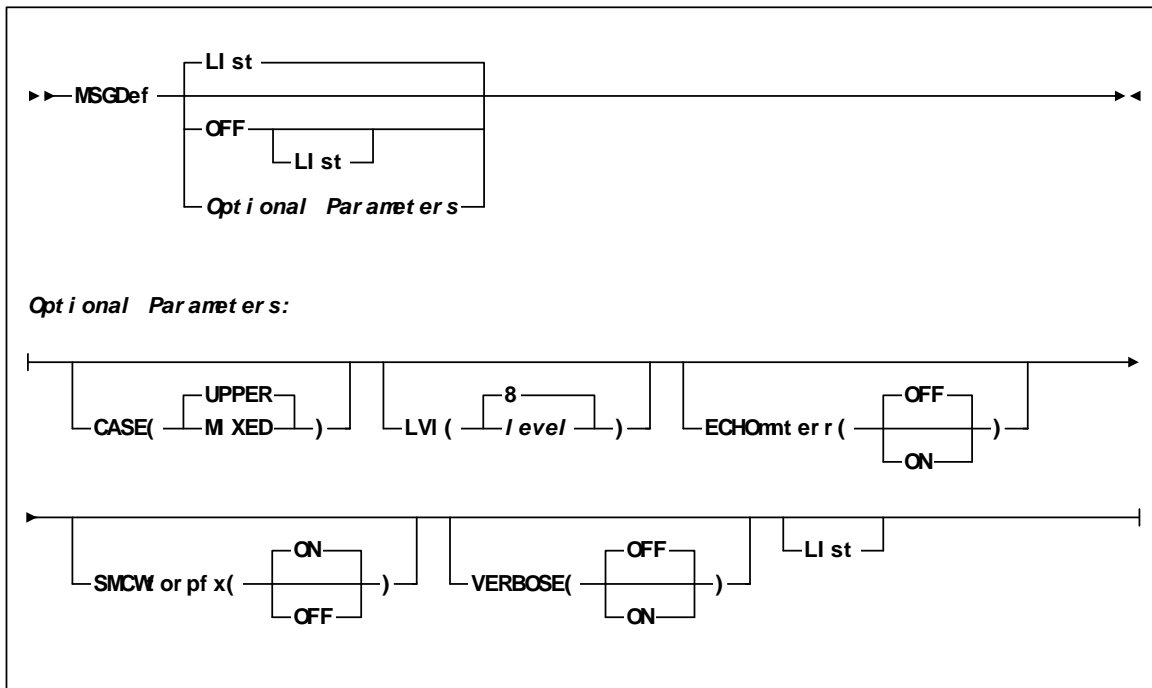

MSGJob

Interfaces:

Console, utility, or SMCCMDS/SMCPARMS data set
 UUI: Yes (No XML/CSV output)

Subsystem Requirements:

Active SMC required, or may be input to the SMCUSIM utility

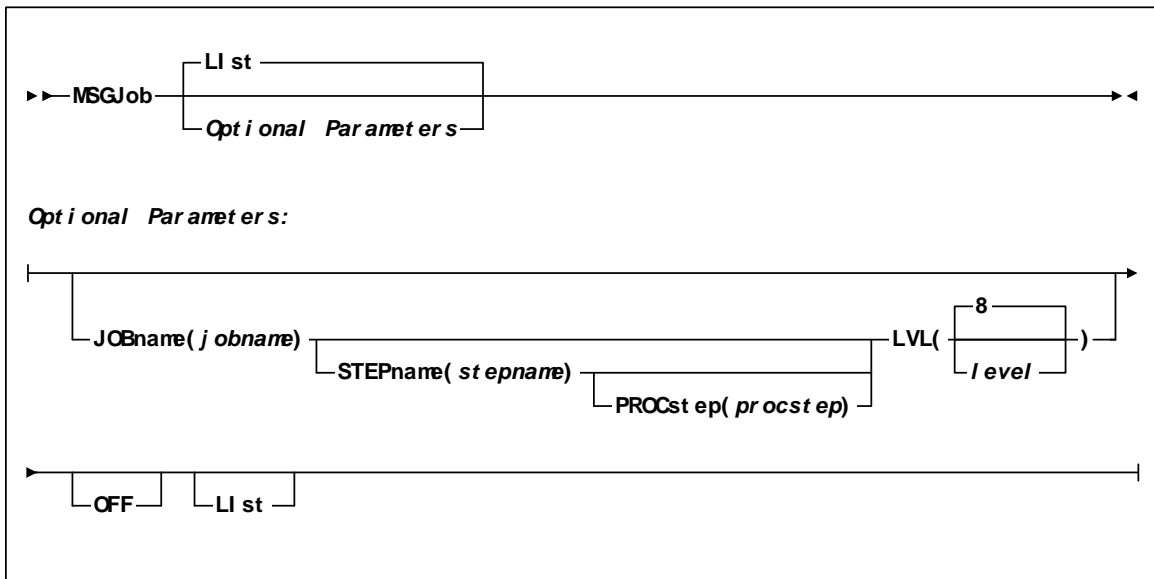

POLicy

Interfaces:

Console, utility, or SMCCMDS/SMCPARMS data set
 UUI: Yes (No XML/CSV output)

Subsystem Requirements:

Active SMC required, or may be input to the SMCUSIM utility

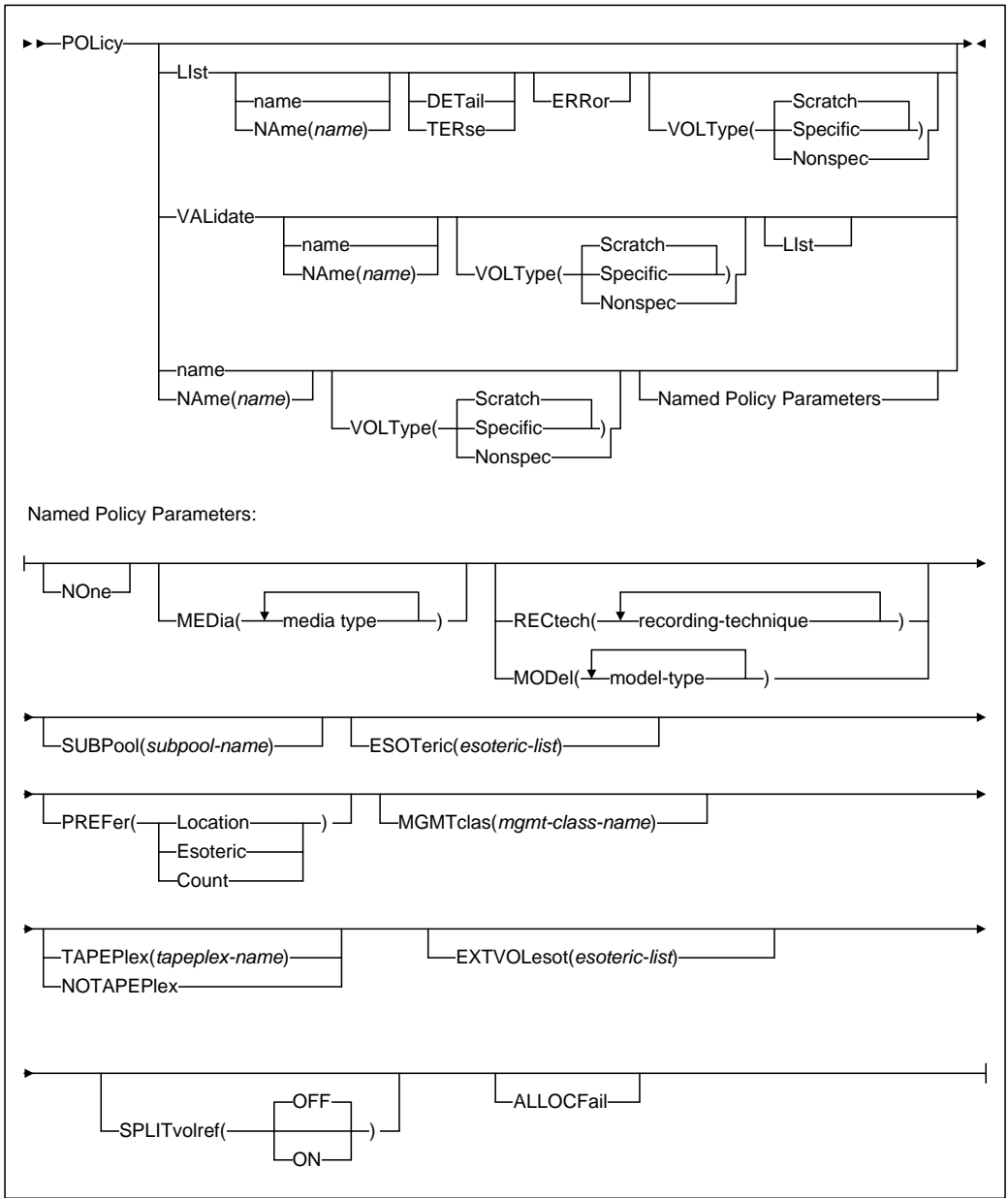

READ

Interfaces:

Console, utility, or SMCCMDS/SMCPARMS data set
 UUI: Yes (No XML/CSV output)

Subsystem Requirements:

Active SMC required, or may be input to the SMCUSIM utility

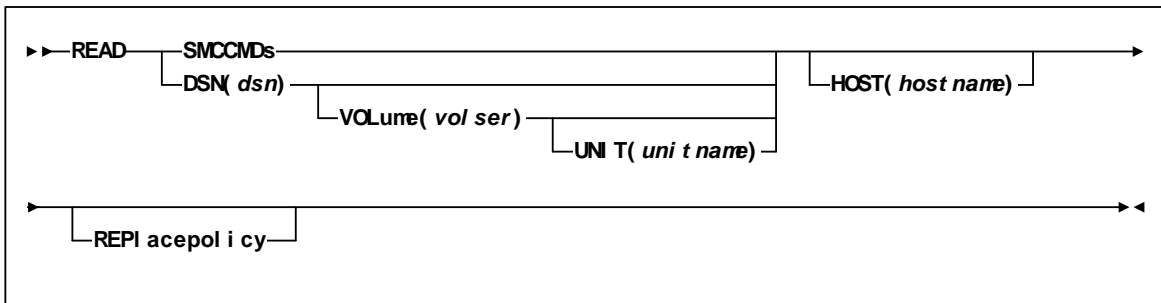

RESYNChronize

Interfaces:

Console, utility, or SMCCMDS/SMCPARMS data set
 UUI: Yes (No XML/CSV output)

Subsystem Requirements:

Active SMC required, or may be input to the SMCUSIM utility

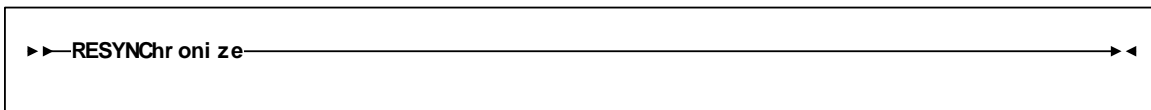

Route

Interfaces:

Console, utility, or SMCCMDS/SMCPARMS data set
UII: Yes (No XML/CSV output)

Subsystem Requirements:

Active SMC required

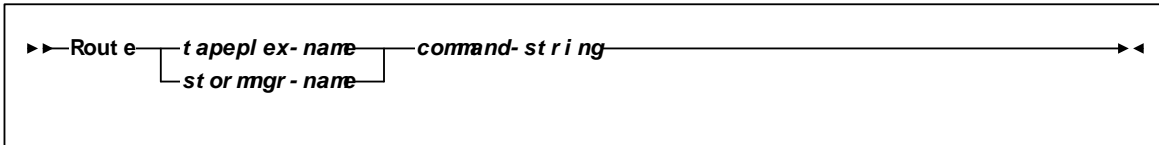

SERVer

Interfaces:

Console, utility, or SMCCMDS/SMCPARMS data set
 UUI: Yes (No XML/CSV output)

Subsystem Requirements:

Active SMC required, or may be input to the SMCUSIM utility

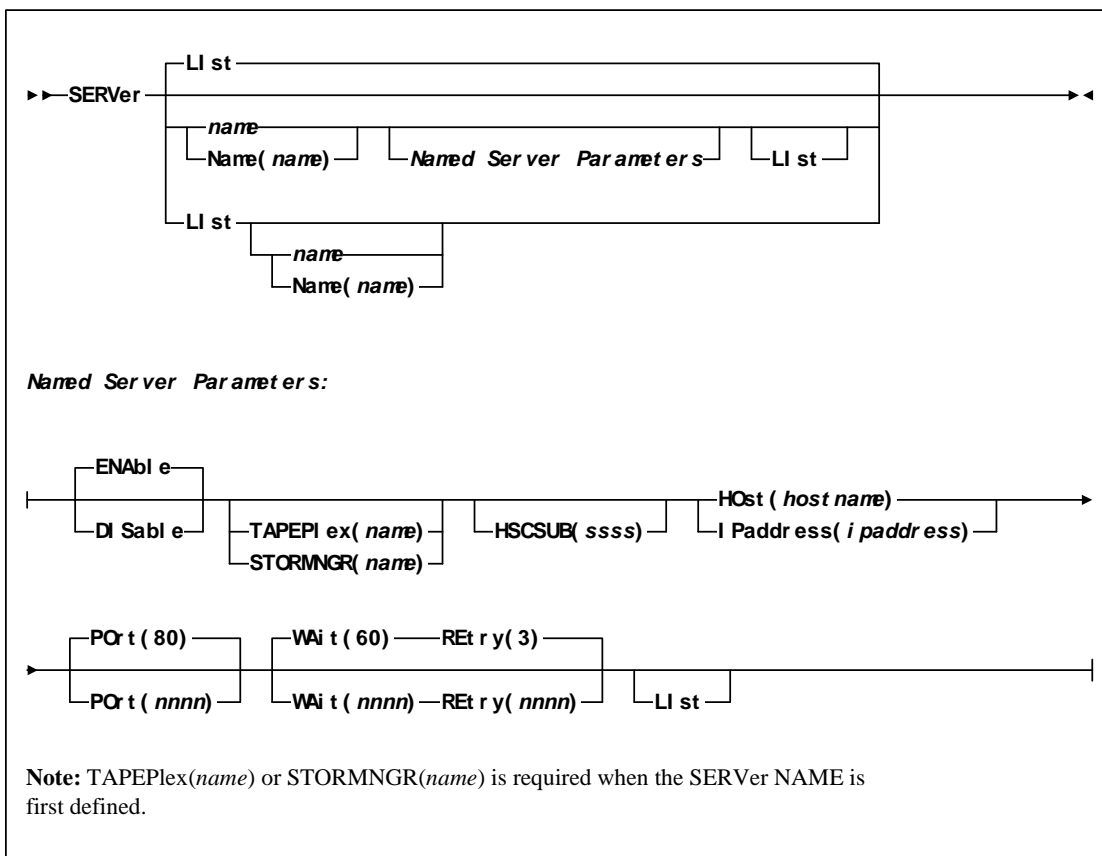

SIMulate

Interfaces:

Console, utility, or SMCCMDS/SMCPARMS data set
 UUI: Yes (No XML/CSV output)

Subsystem Requirements:

Active SMC required, or may be input to the SMCUSIM utility

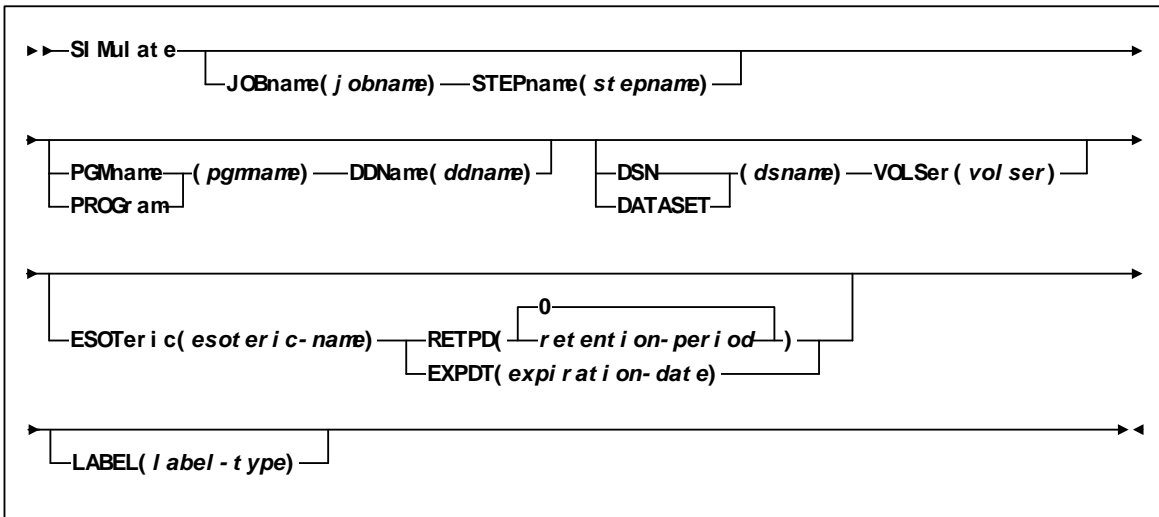

STORMNGR

Interfaces:

Console, utility, or SMCCMDS/SMCPARMS data set
 UUI: Yes (No XML/CSV output)

Subsystem Requirements:

Active SMC required, or may be input to the SMCUSIM utility

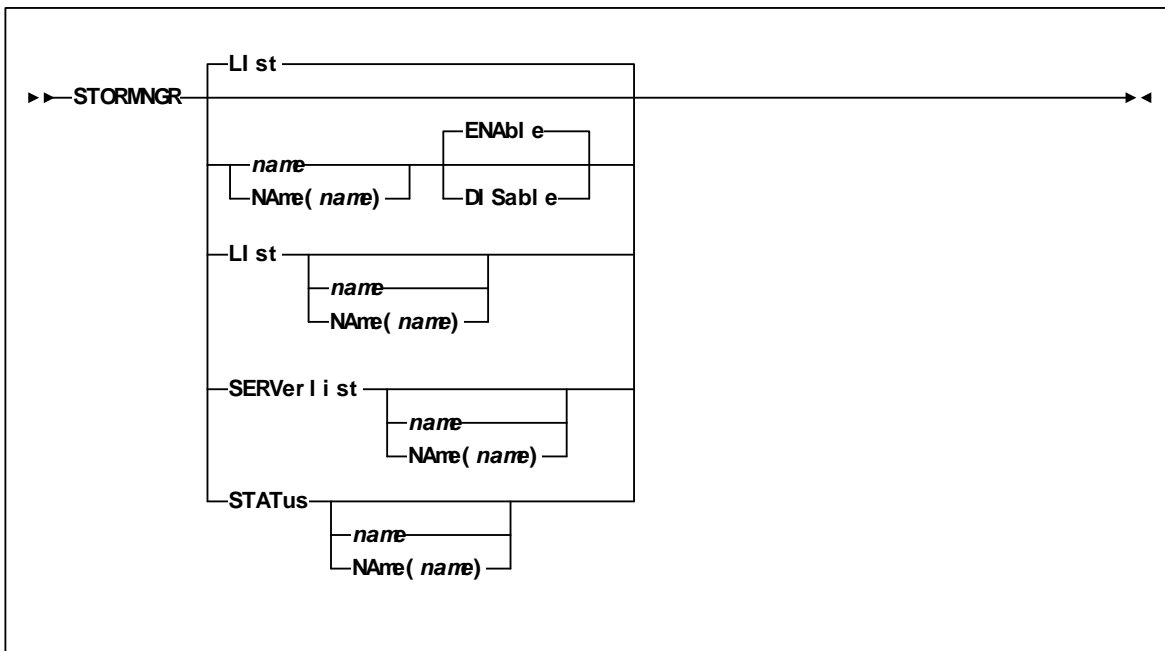

TAPEplex

Interfaces:

Console, utility, or SMCCMDS/SMCPARMS data set
 UUI: Yes (No XML/CSV output)

Subsystem Requirements:

Active SMC required, or may be input to the SMCUSIM utility

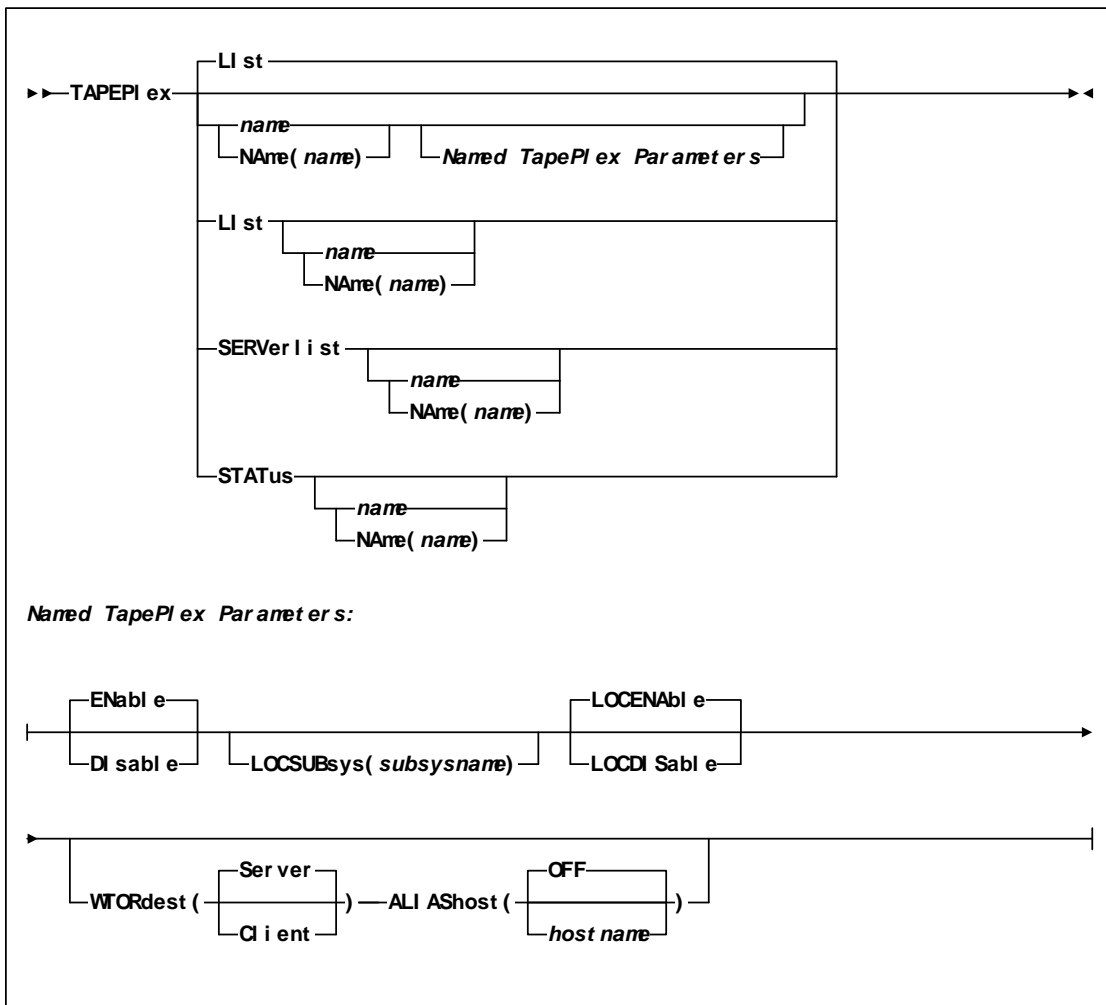

TCPip

Interfaces:

Console, utility, or SMCCMDS/SMCPARMS data set
 UUI: Yes (No XML/CSV output)

Subsystem Requirements:

Active SMC required, or may be input to the SMCUSIM utility

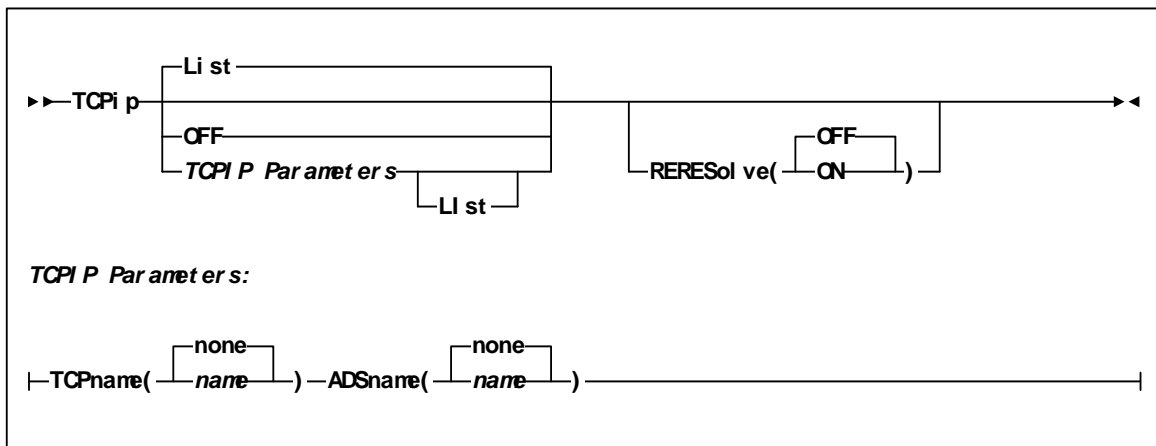

TRace

Interfaces:

Console, utility, or SMCCMDS/SMCPARMS data set
 UUI: Yes (No XML/CSV output)

Subsystem Requirements:

Active SMC required, or may be input to the SMCUSIM utility

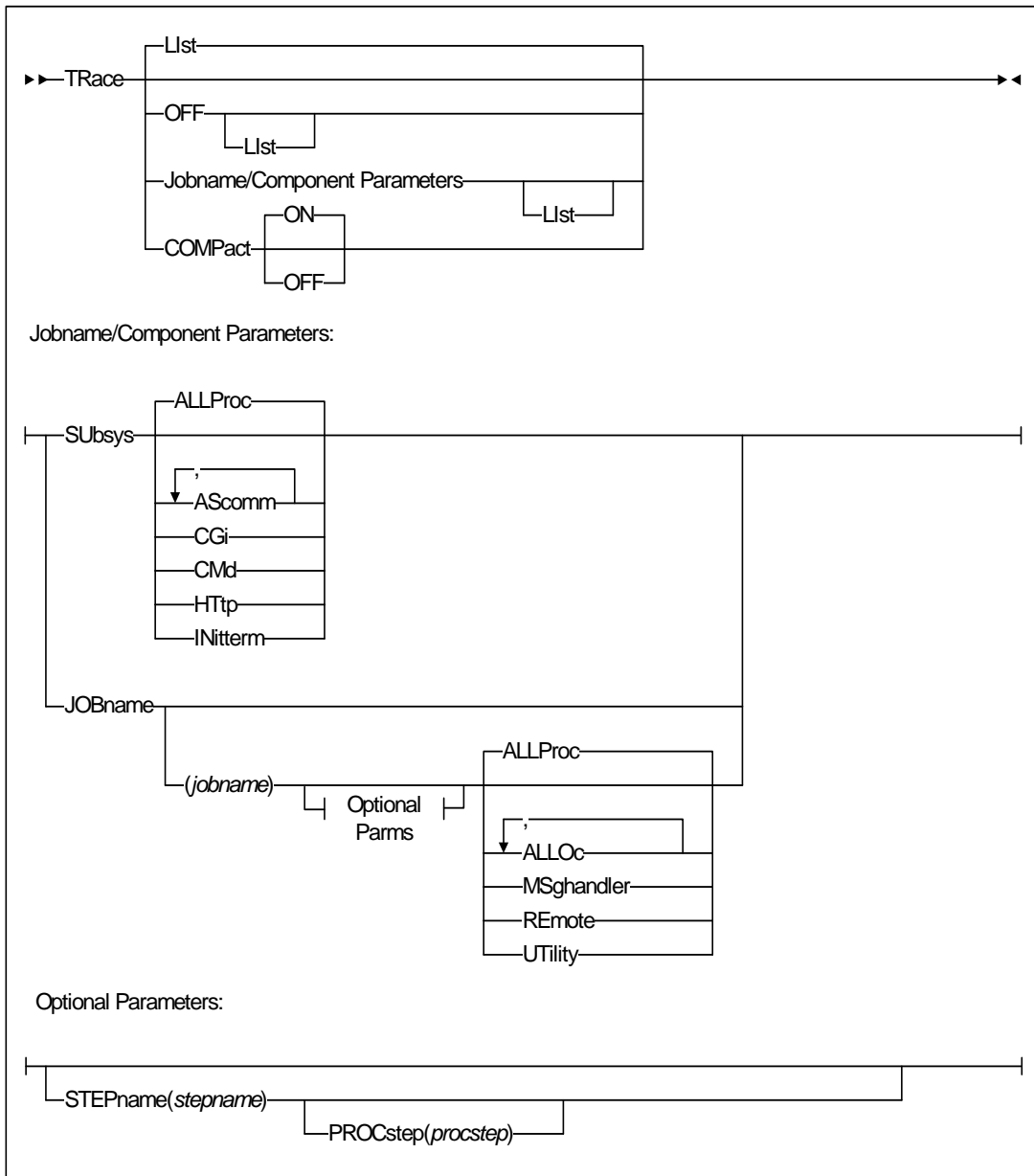

TREQDef

Interfaces:

Console, utility, or SMCCMDS/SMCPARMS data set
 UUI: Yes (No XML/CSV output)

Subsystem Requirements:

Active SMC required, or may be input to the SMCUSIM utility

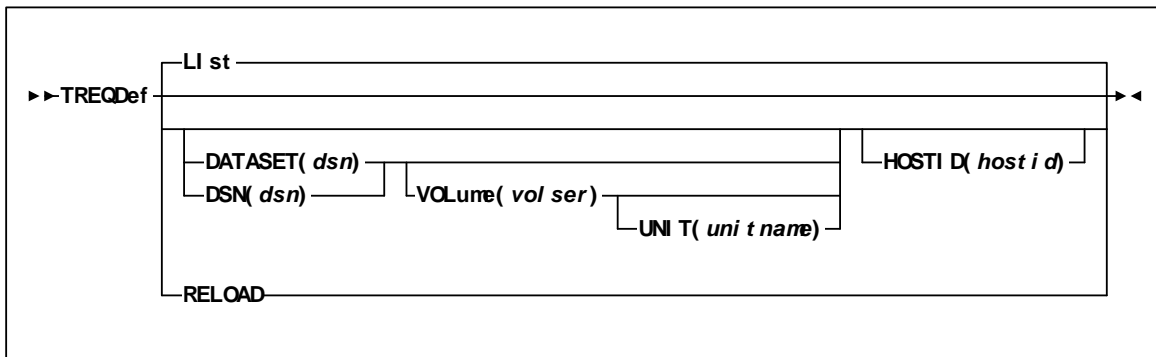

TAPEREQ Control Statement

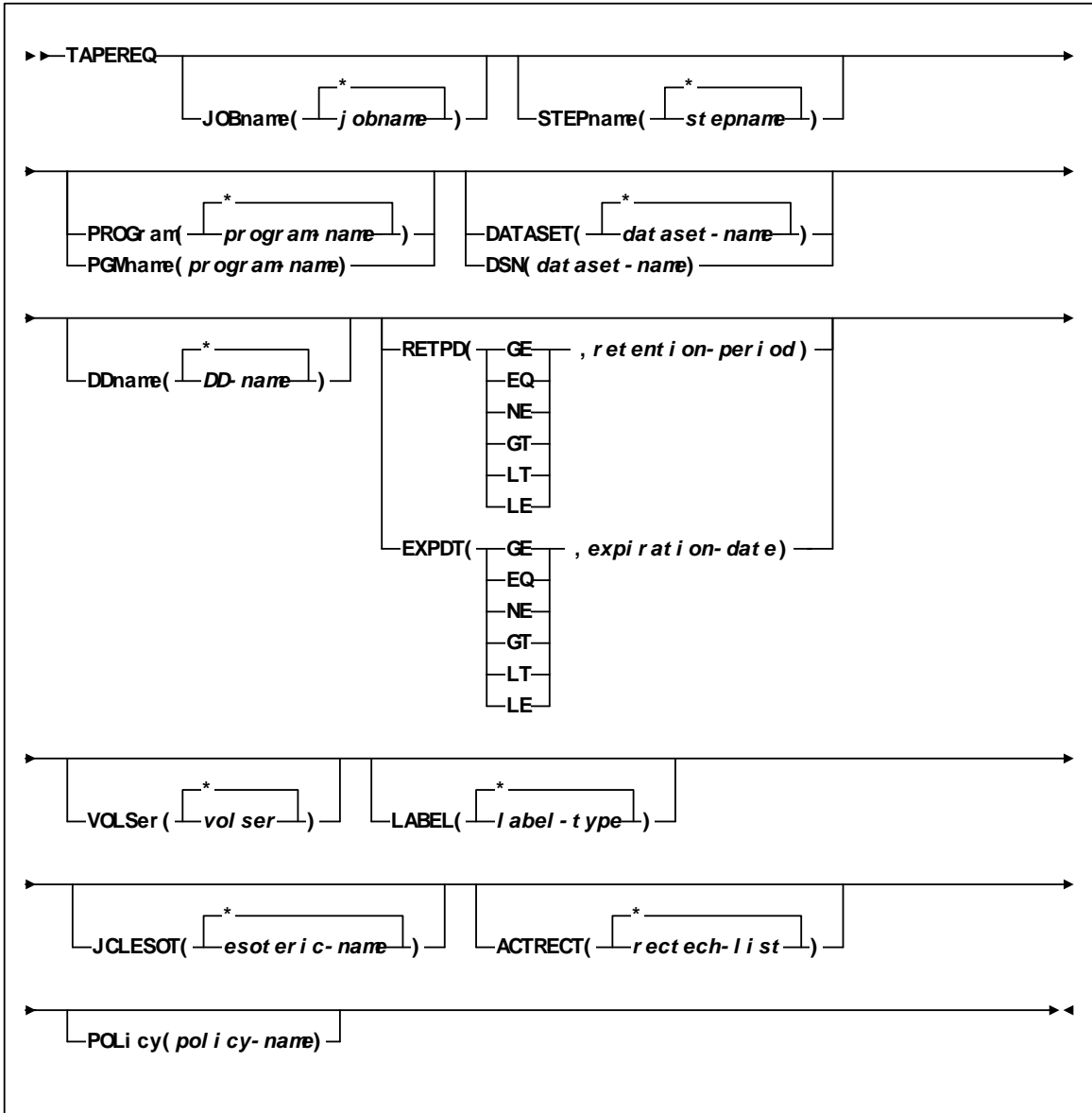

UExit

Interfaces:

Console, utility, or SMCCMDS/SMCPARMS data set
 UUI: Yes (No XML/CSV output)

Subsystem Requirements:

Active SMC required, or may be input to the SMCUSIM utility

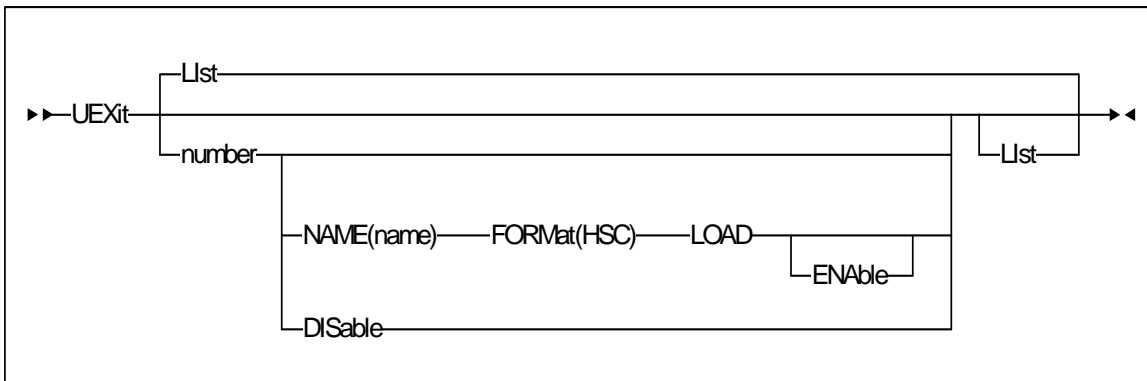

UNITAttr

Interfaces:

Console or SMCCMDS data set
 UUI: Yes (No XML/CSV output)

Subsystem Requirements:

Active SMC required, or may be input to the SMCUSIM utility

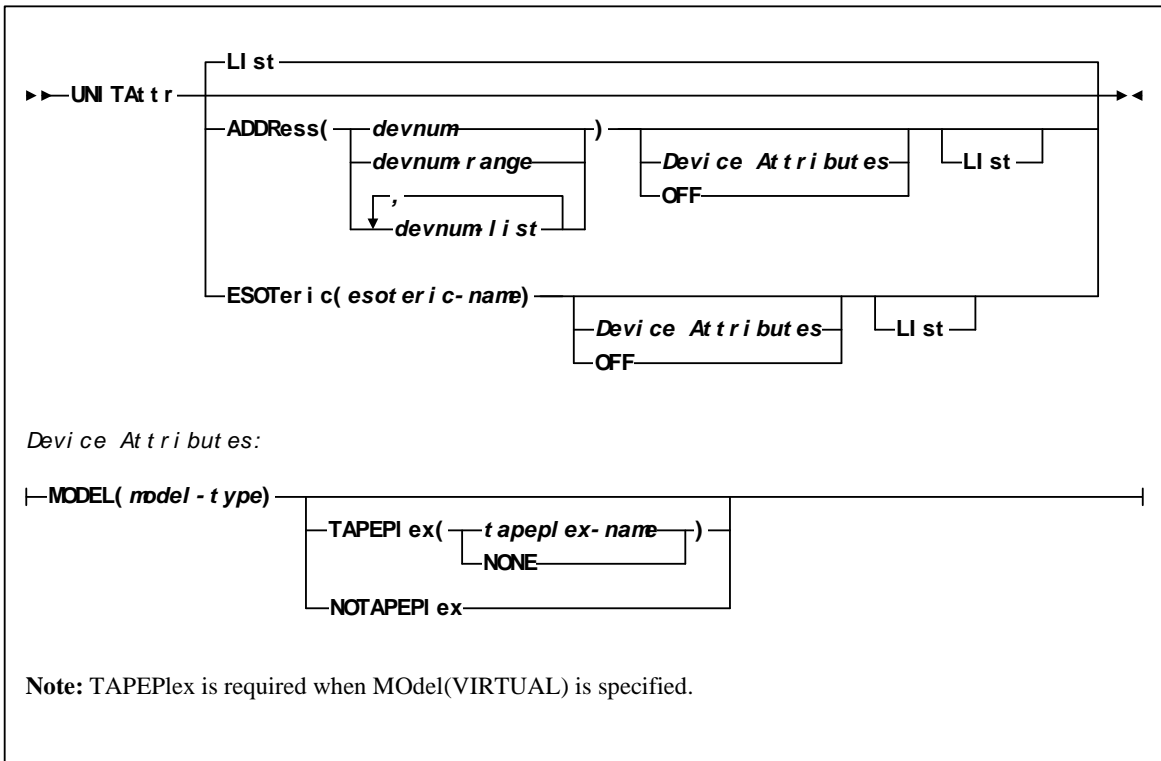

USERMsg

Interfaces:

Console or SMCPARMS data set
UUI: Yes (No XML/CSV output)

Subsystem Requirements:

Active SMC required, or may be input to the SMCUSIM utility

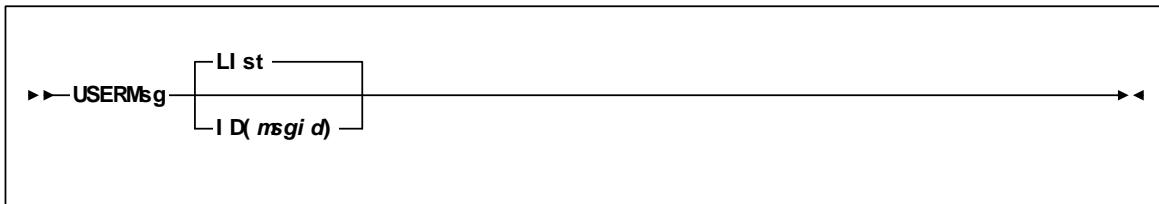

USERMsg

HSC and VTCS Commands and Control Statements

This chapter contains syntax for HSC commands and control statements. Interface and subsystem requirement information is included with each command.

Control statements that are loaded by an operator command are described along with that command.

Note –

- For detailed information about the commands and control statements included in this publication, and the interfaces used to issue them, refer to the *ELS Command, Control Statement, and Utility Reference*.
 - Certain HSC and VTCS commands are described in the *ELS Legacy Interfaces Guide*. These commands were introduced in a pre-ELS 7.0 software release and their functionality has been replaced.
-

ACTivities

Interfaces:

SLUADMIN utility only
UII: No

Subsystem Requirements:

Active HSC not required

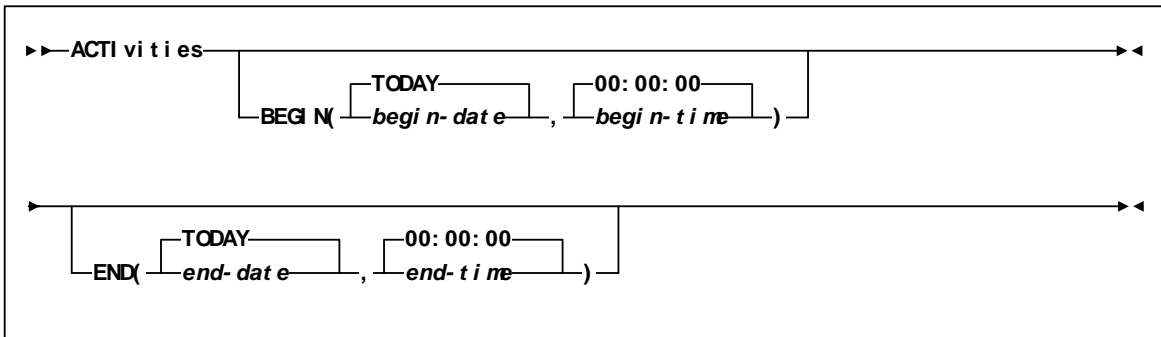

ACTMVCgn

Interfaces:

SLUADMIN utility only
UII: Yes

Subsystem Requirements:

Active HSC required only when specifying the MVCPOOL parameter

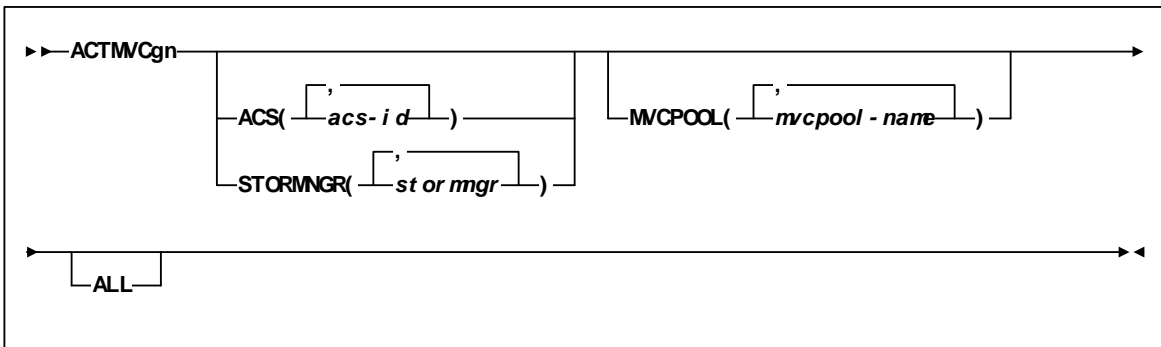

ARCHive

Interfaces:

Utility only
 UUI: Yes

Subsystem Requirements:

Active HSC not required

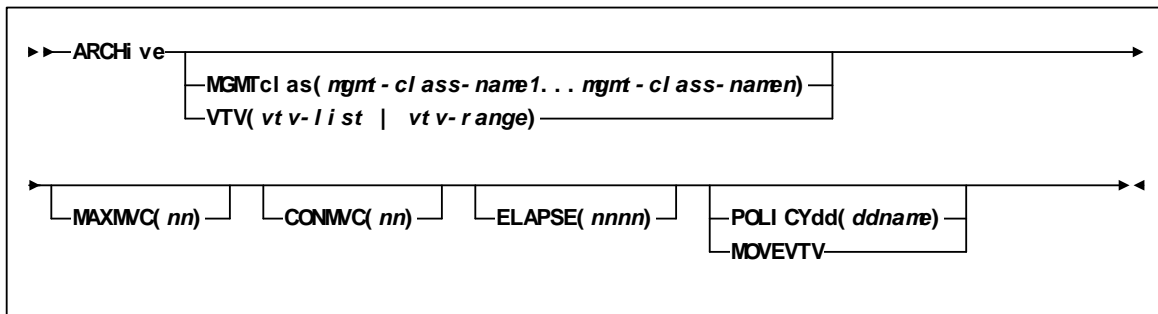

AUDit

Interfaces:

Utility only

UUI: Yes, when MVC or VTSS is specified

Subsystem Requirements:

- Active HSC/VTCS (AUDit MVC, VTSS, or INVLDMIR)
- Active HSC at FULL service level (all others)

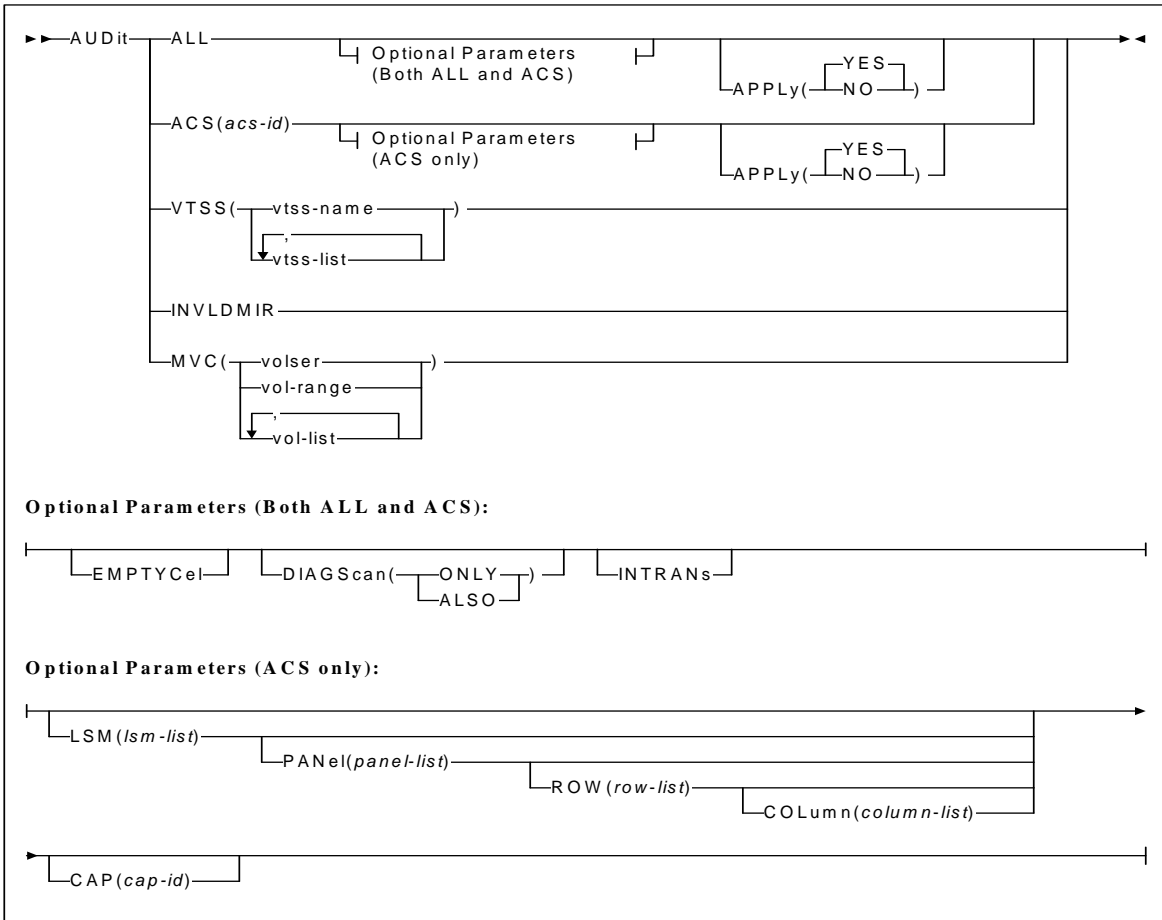

BACKup

Interfaces:

SLUADMIN utility only
 UUI: No

Subsystem Requirements:

Active HSC not required

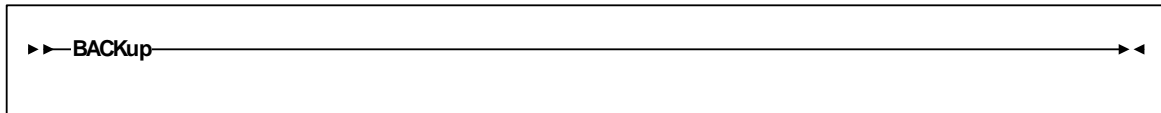

CANcel

Interfaces:

Console or utility
 UUI: Yes

Subsystem Requirements:

Active HSC/VTCS

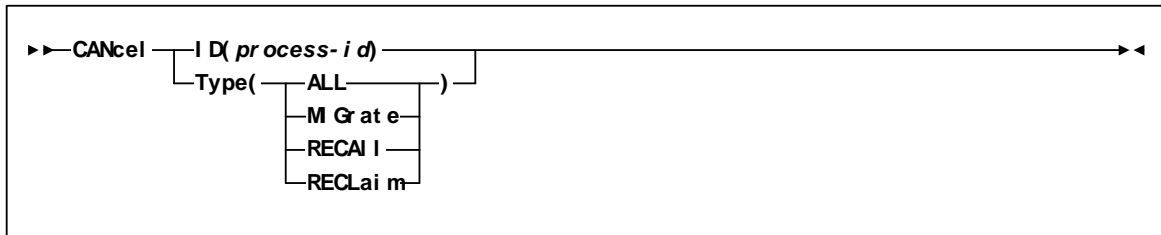

CAPPref

Interfaces:

Console or PARMLIB
 UUI: No

Subsystem Requirements:

Active HSC at FULL service level

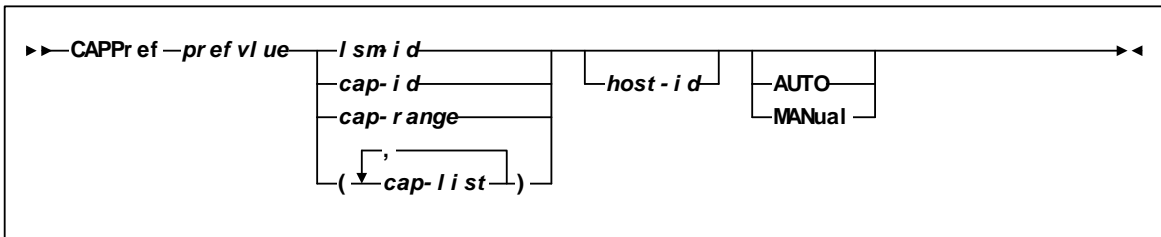

CDs

Interfaces:

Console or PARMLIB
 UUI: No

Subsystem Requirements:

Active HSC at BASE or FULL service level

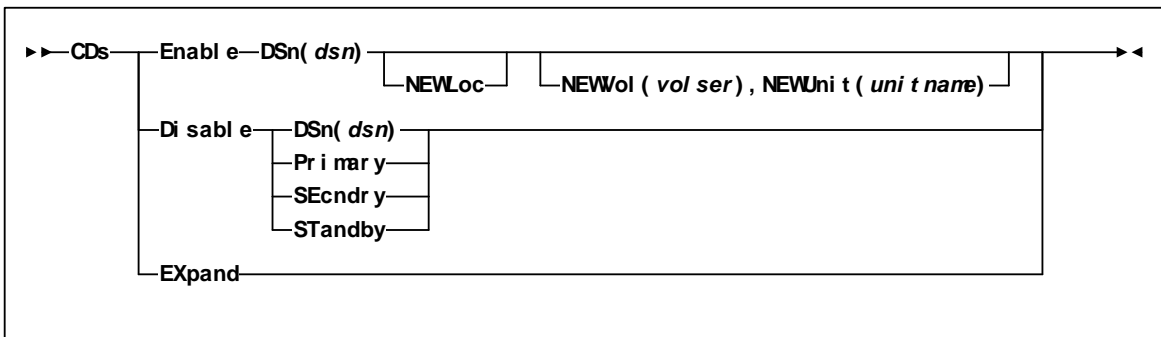

CDSCREat

Interfaces:

SLUADMIN utility only
 UUI: Yes

Subsystem Requirements:

None

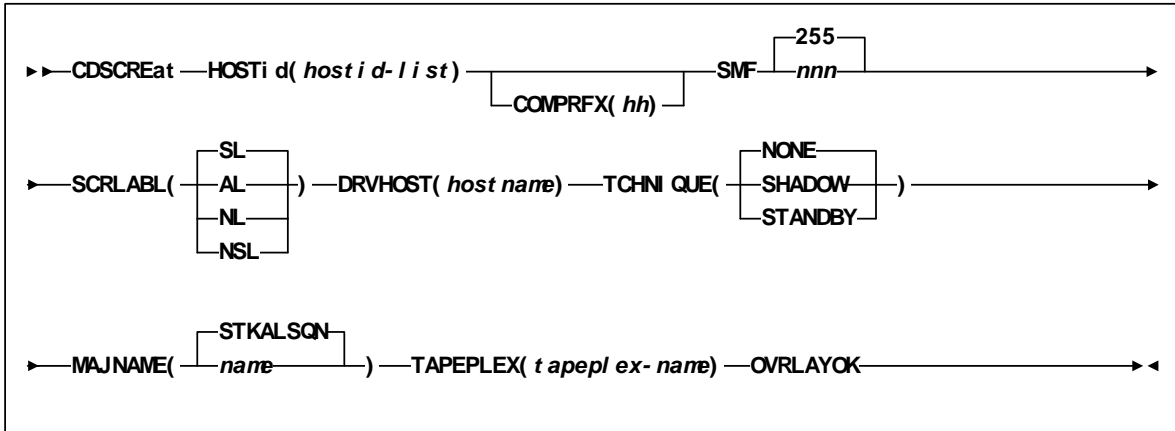

CDSDAta

Interfaces:

Utility only
 UUI: Yes

Subsystem Requirements:

Active HSC not required

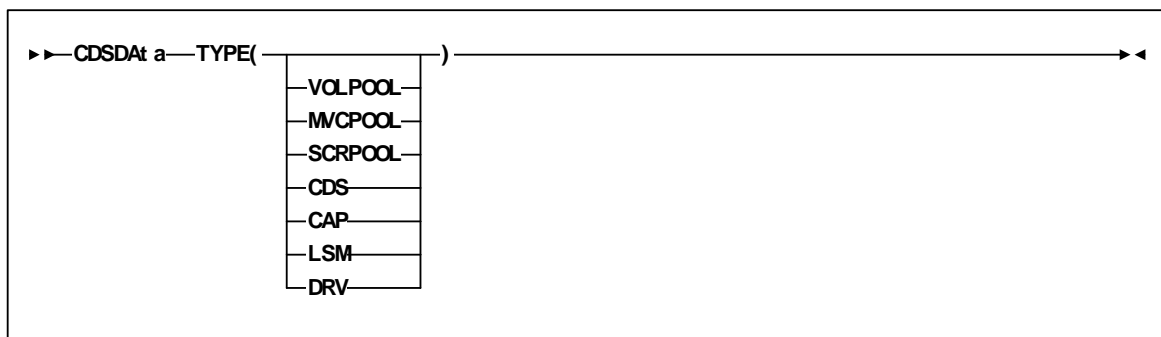

CDSDEF

Interfaces:

PARMLIB only
 UUI: No

Subsystem Requirements:

None

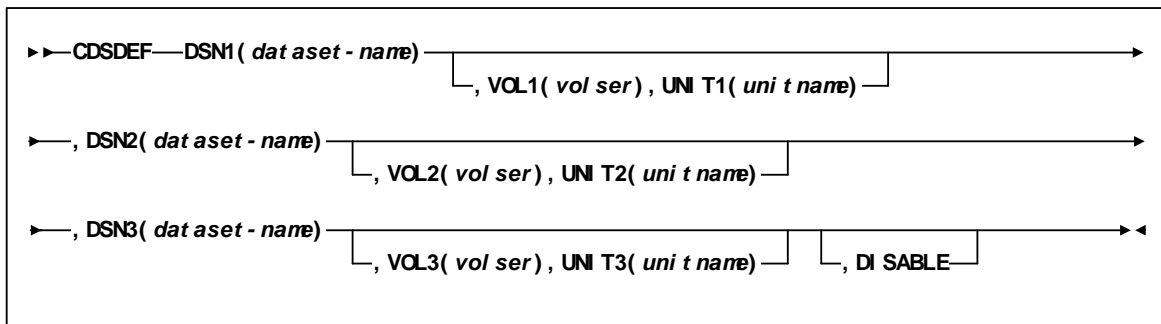

CLean

Interfaces:

Console or PARMLIB
 UUI: No

Subsystem Requirements:

Active HSC at FULL service level

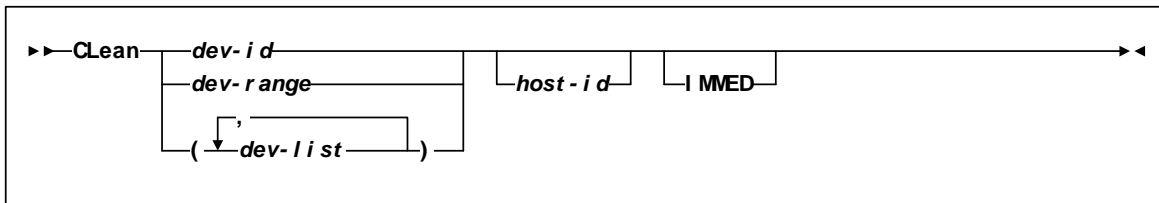

COMMPath

Interfaces:

Console or PARMLIB only
 UUI: No

Subsystem Requirements:

Active HSC at BASE or FULL service level

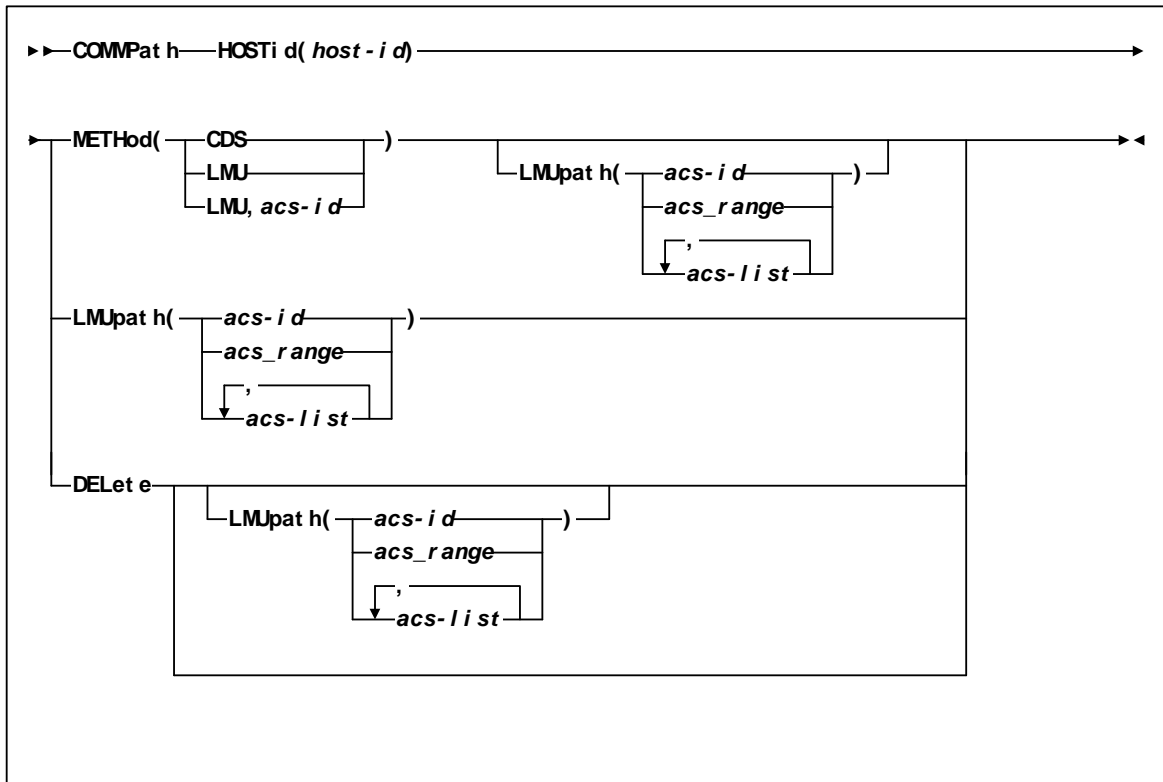

CONFIg

Interfaces:

Utility only
UUI: Yes

Subsystem Requirements:

Active HSC not required, and must be down on all hosts when running CONFIG RESET.

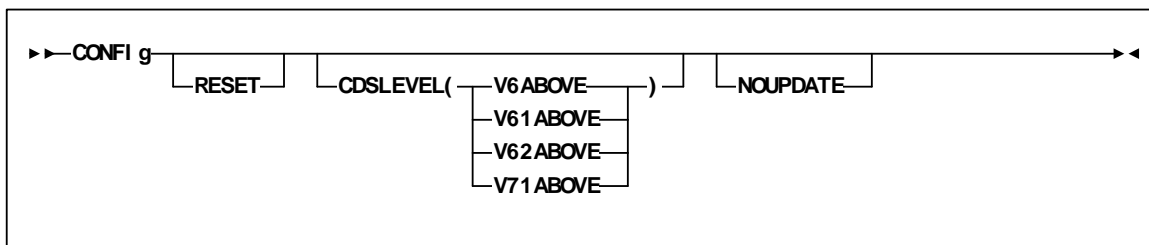

CONFIg GLOBAL Statement

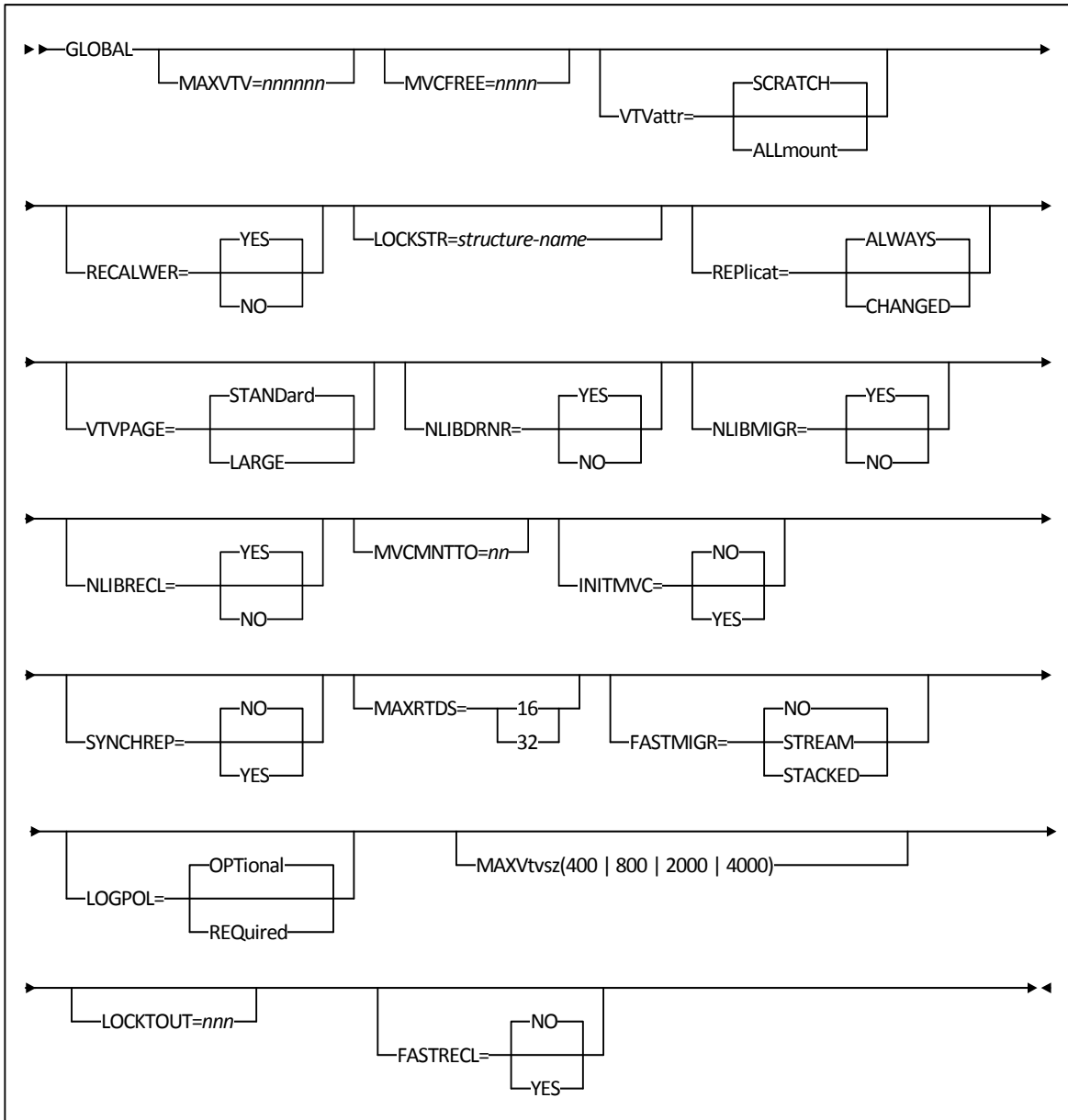

CONFIg RECLAIM Statement

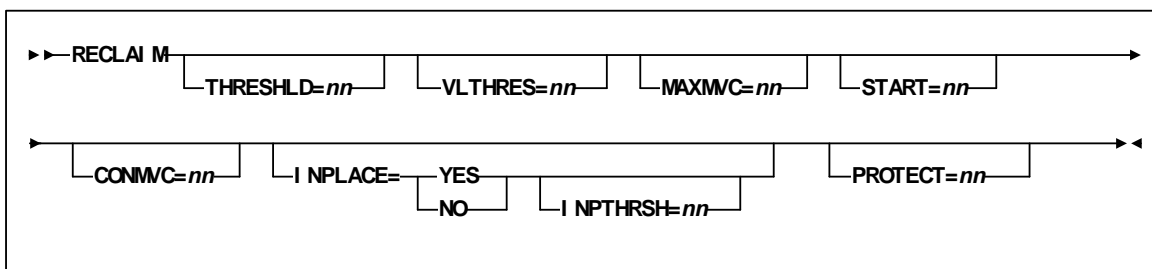

CONFIg VTSS Statement

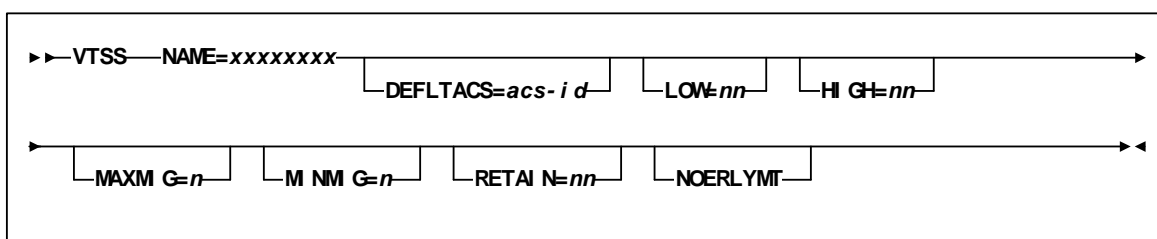

CONFIg RTD Statement

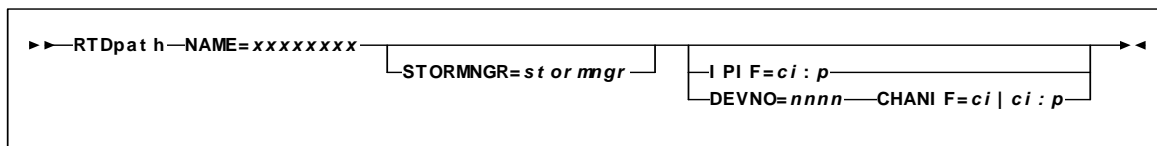

CONFIg VTD Statement

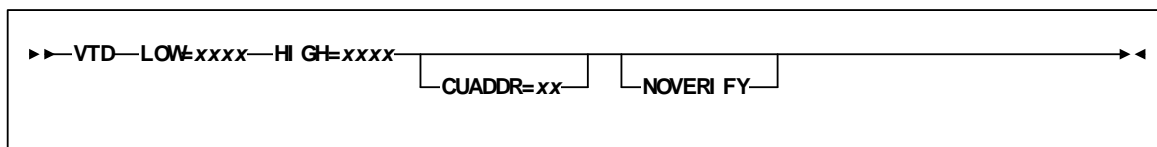

CONFIg CLUSTER Statement

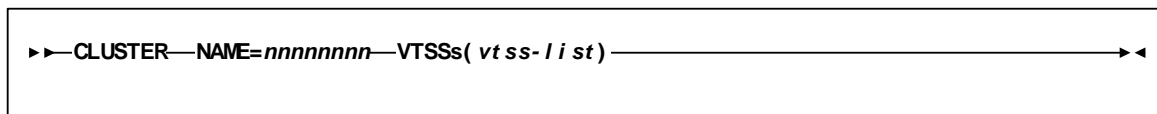

CONFIg CLINK Statement

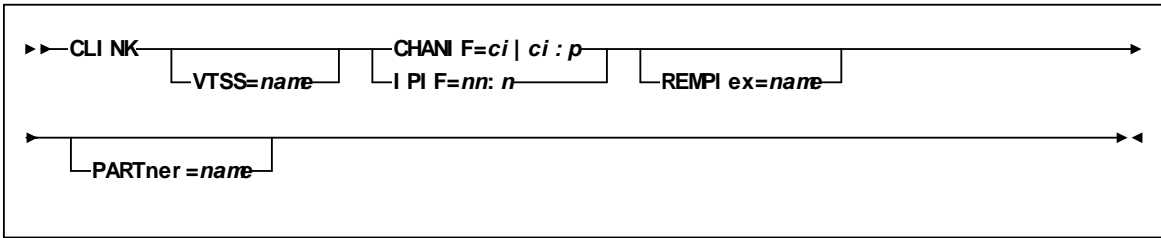

CONFIg HOST Statement

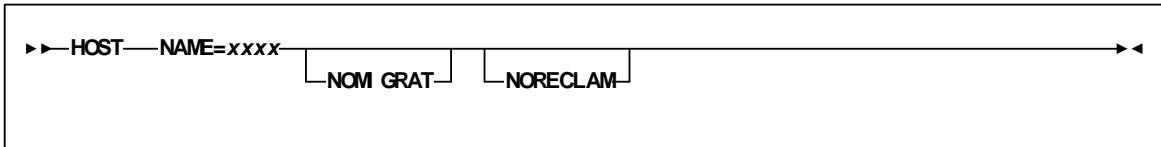

CONFIg TAPEPLEX Statement

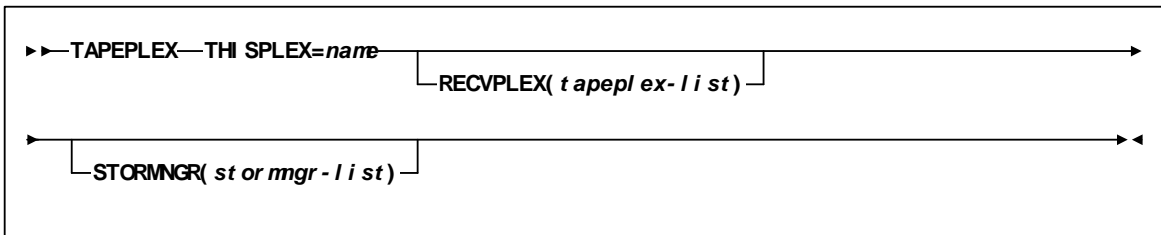

CONSolid

Interfaces:

Console or utility
 UUI: Yes

Subsystem Requirements:

Active HSC/VTCS

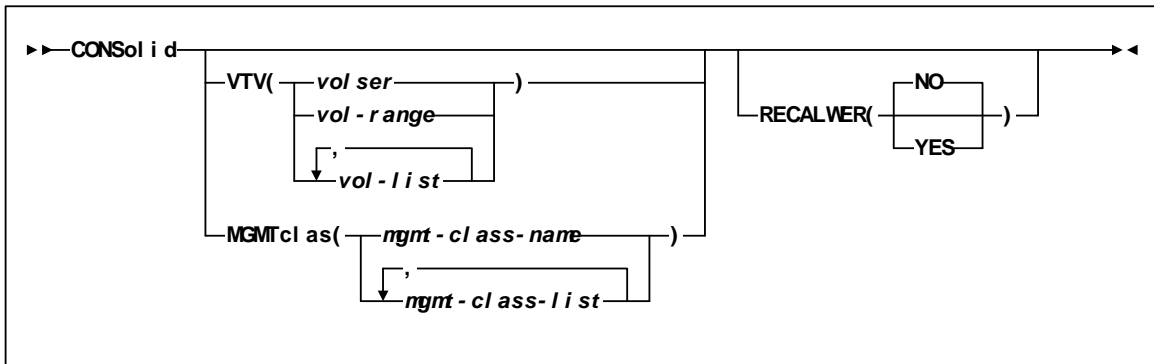

DEComp

Interfaces:

Utility only
 UUI: Yes

Subsystem Requirements:

Active HSC not required

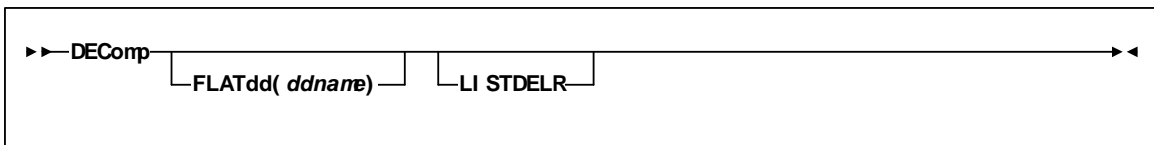

DELETSCR

Interfaces:

Console or utility
 UUI: Yes

Subsystem Requirements:

Active HSC/VTCS

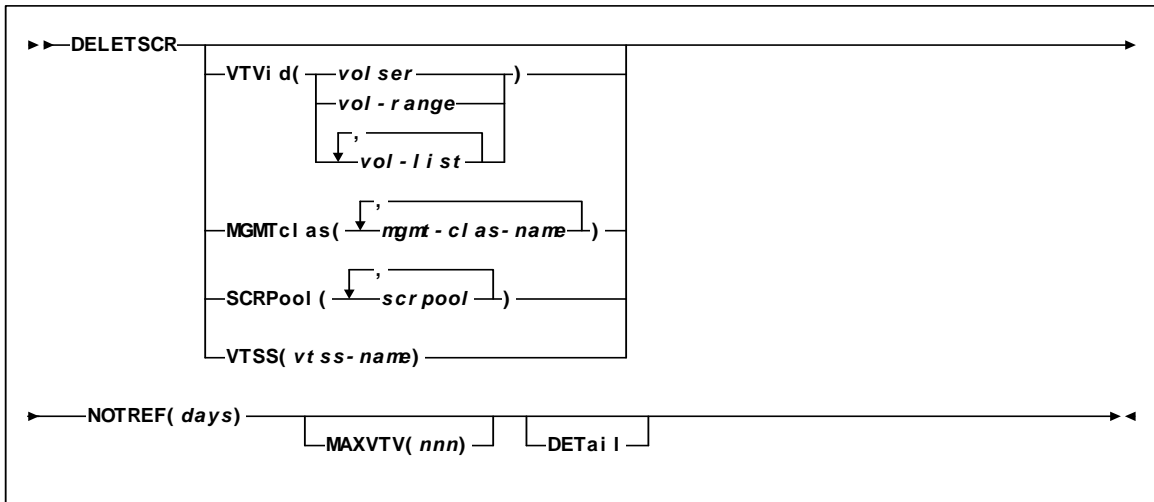

DIRBLD

Interfaces:

Utility only
 UUI: No

Subsystem Requirements:

Active HSC not required

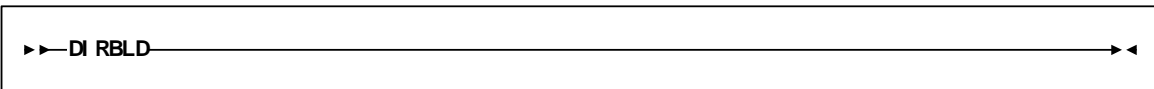

DISMount

Interfaces:

Console or utility
 UUI: Yes

Subsystem Requirements:

Active HSC at FULL service level

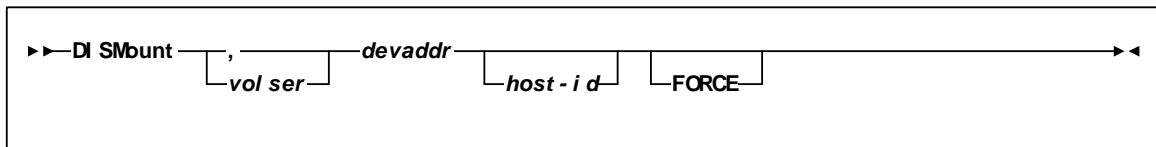

Display Acs

Interfaces:

Console or utility
 UUI: Yes

Subsystem Requirements:

Active HSC at FULL service level

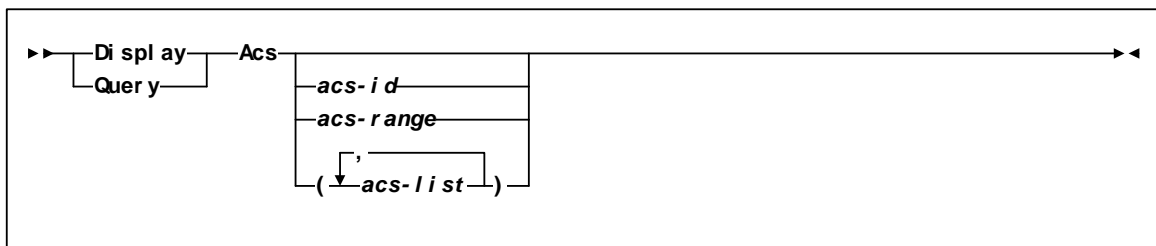

Display ACTive

Interfaces:

Console or utility
UUI: Yes

Subsystem Requirements:

Active HSC/VTCS

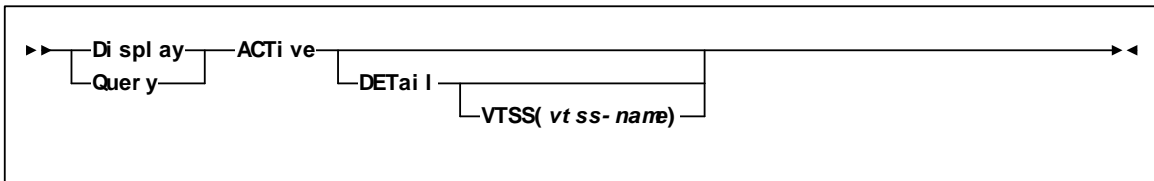

Display ALI

Interfaces:

Console or PARMLIB only
UUI: No

Subsystem Requirements:

Active HSC at FULL service level

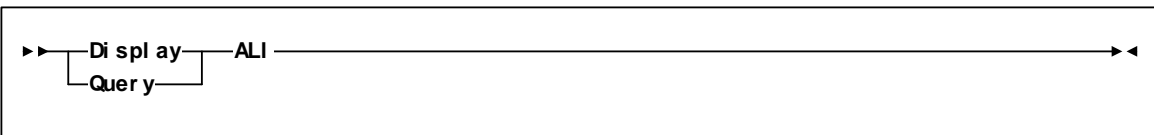

Display Cap

Interfaces:

Console or utility
 UUI: Yes

Subsystem Requirements:

Active HSC at FULL service level

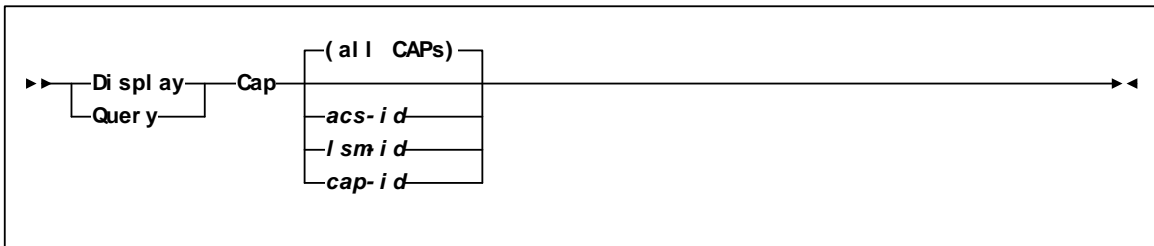

Display CDS

Interfaces:

Console or utility
 UUI: Yes

Subsystem Requirements:

Active HSC at BASE or FULL service level

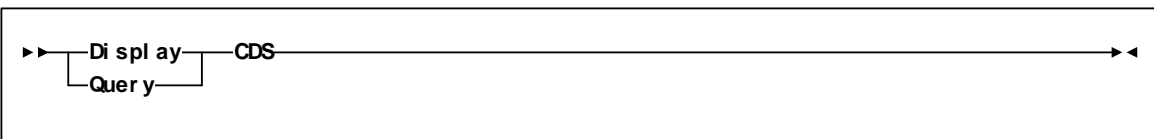

Display CLInk

Interfaces:

Console or utility
UII: Yes

Subsystem Requirements:

Active HSC/VTCS

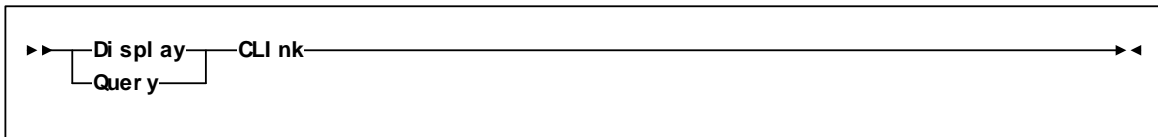

Display CLUster

Interfaces:

Console or utility
UII: Yes

Subsystem Requirements:

Active HSC/VTCS

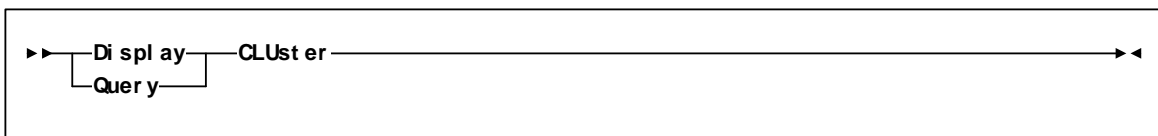

Display CMD

Interfaces:

Console or utility
 UUI: Yes

Subsystem Requirements:

Active HSC at BASE or FULL service level

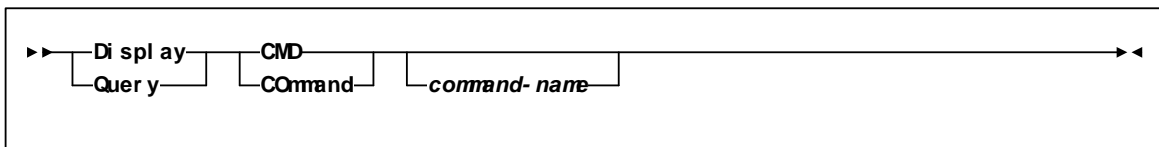

Display COMMPath

Interfaces:

Console or PARMLIB only
 UUI: No

Subsystem Requirements:

Active HSC at BASE or FULL service level

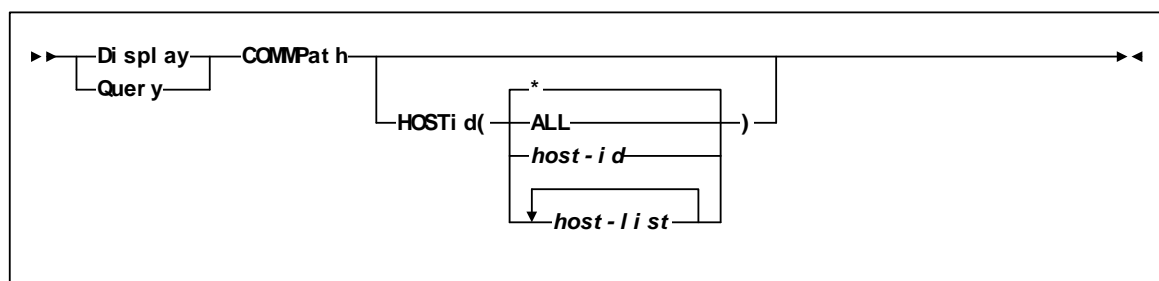

Display CONFIG

Interfaces:

Console or utility
UII: Yes

Subsystem Requirements:

Active HSC at FULL service level

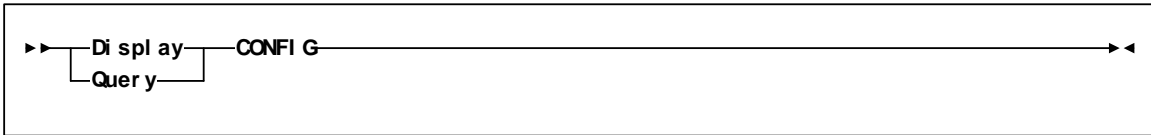

Display DRives

Interfaces:

Console or utility
UII: Yes

Subsystem Requirements:

Active HSC at FULL service level

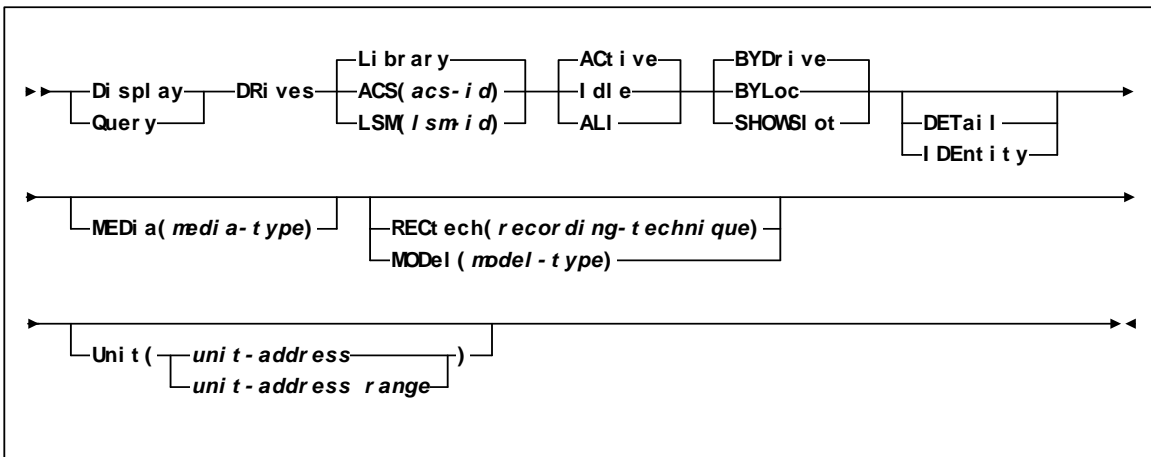

Display DRIVE_INFO

Interfaces:

Console or utility
 UUI: Yes

Subsystem Requirements:

Active HSC/VTCS

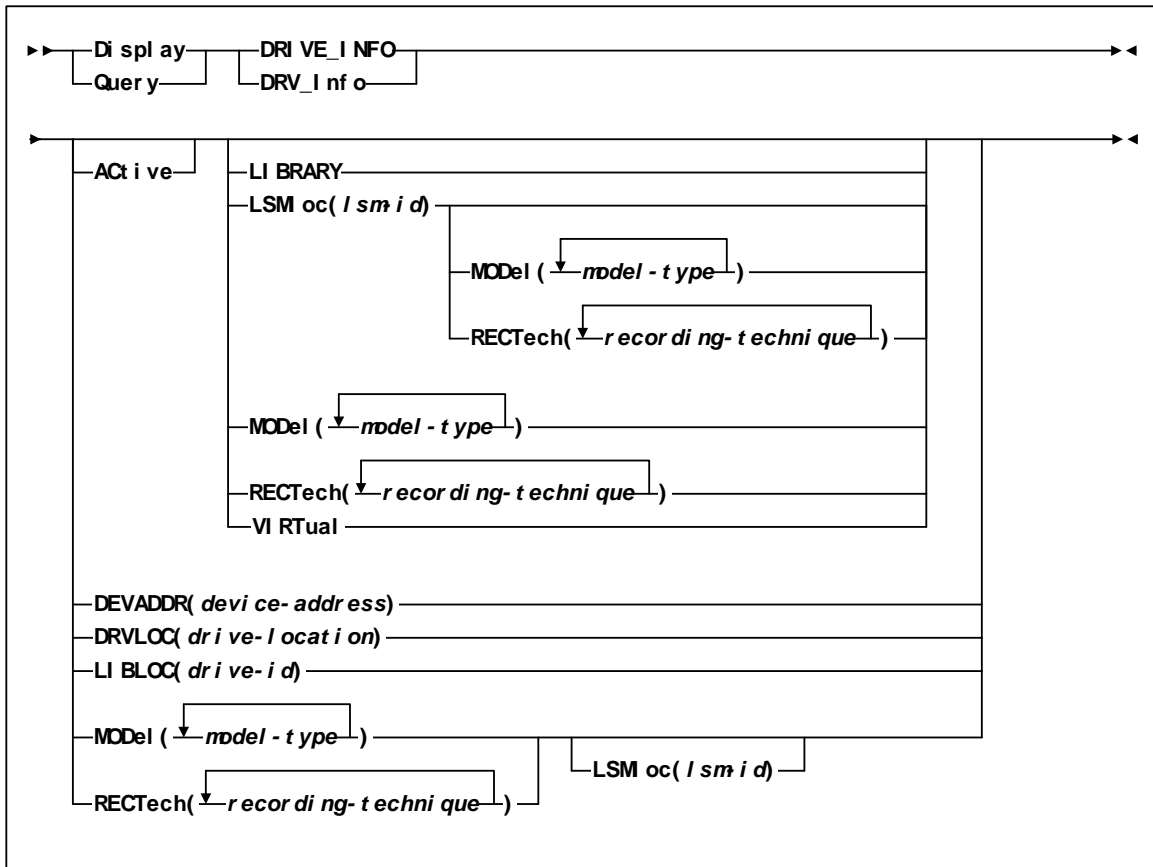

Display EXceptns

Interfaces:

Console or PARMLIB
UII: No

Subsystem Requirements:

Active HSC at FULL service level

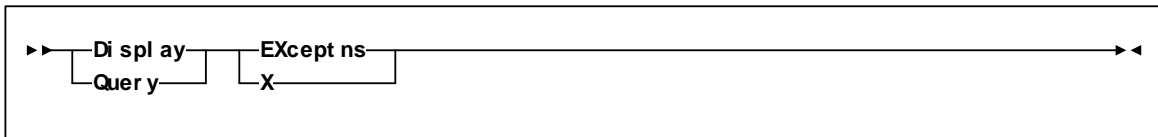

Display LMUPDEF

Interfaces:

Console or PARMLIB
UII: No

Subsystem Requirements:

Active HSC at BASE or FULL service level

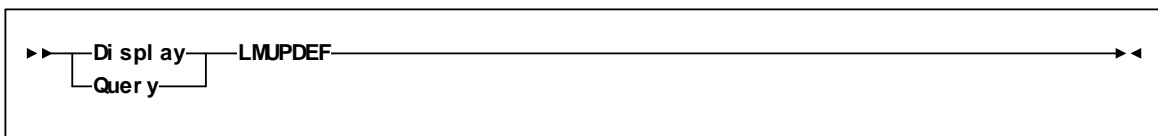

Display LOCKs

Interfaces:

Console or utility
 UUI: Yes

Subsystem Requirements:

Active HSC/VTCS

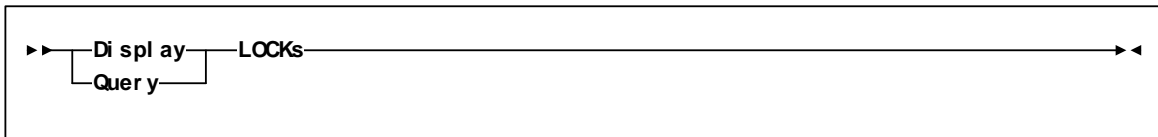

Display Lsm

Interfaces:

Console or utility
 UUI: Yes

Subsystem Requirements:

Active HSC at FULL service level

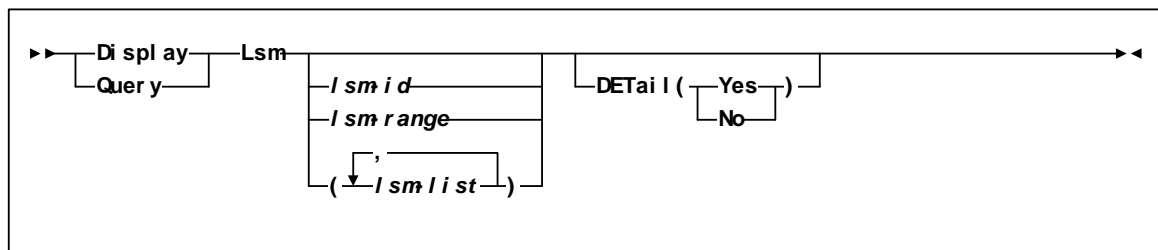

Display Message

Interfaces:

Console or utility
UII: Yes

Subsystem Requirements:

Active HSC at BASE or FULL service level

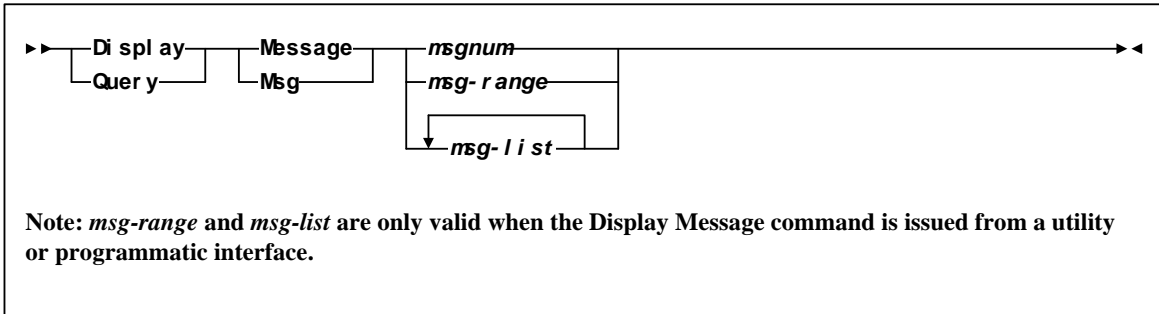

Display MGMTDEF

Interfaces:

Console or PARMLIB
UII: No

Subsystem Requirements:

Active HSC at BASE or FULL service level

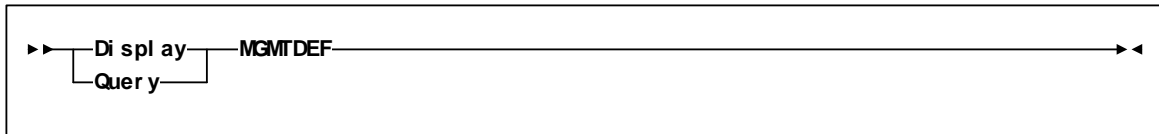

Display MIGrate

Interfaces:

Console or utility
 UUI: Yes

Subsystem Requirements:

Active HSC/VTCS

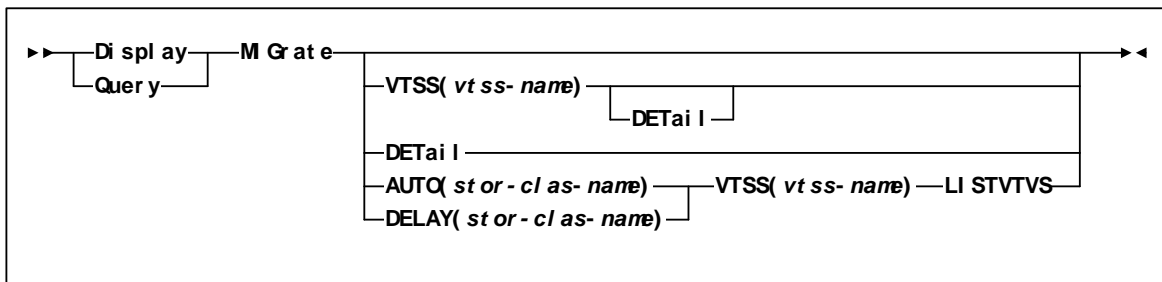

Display MNTD

Interfaces:

Console or PARMLIB
 UUI: No

Subsystem Requirements:

Active HSC at BASE or FULL service level

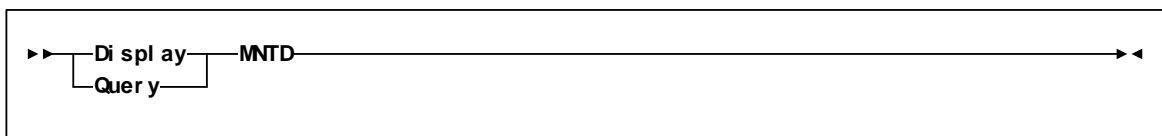

Display MONitor

Interfaces:

Console or PARMLIB
UII: No

Subsystem Requirements:

Active HSC at BASE or FULL service level

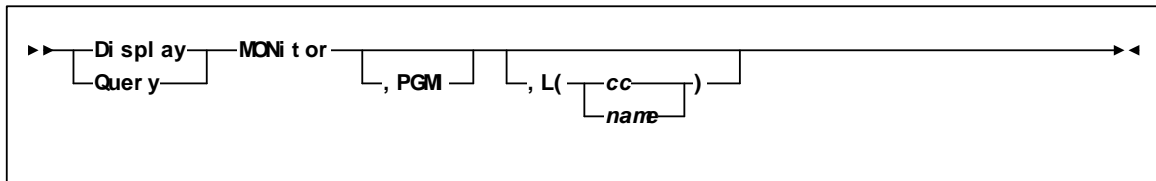

Display MVC

Interfaces:

Console or utility
UII: Yes

Subsystem Requirements:

Active HSC/VTCS

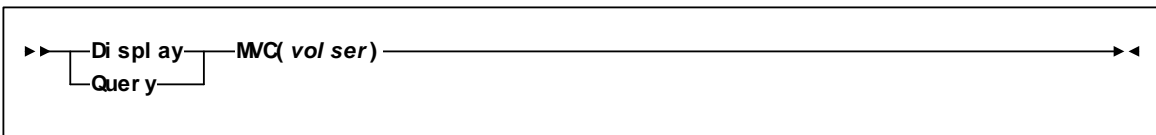

Display MVCPool

Interfaces:

Console or utility
 UUI: Yes

Subsystem Requirements:

Active HSC/VTCS

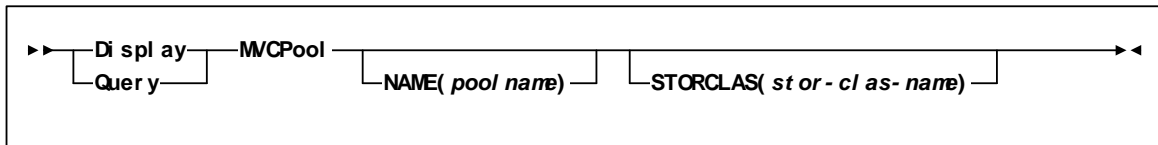

Display OPTion

Interfaces:

Console or PARMLIB
 UUI: No

Subsystem Requirements:

Active HSC at BASE or FULL service level

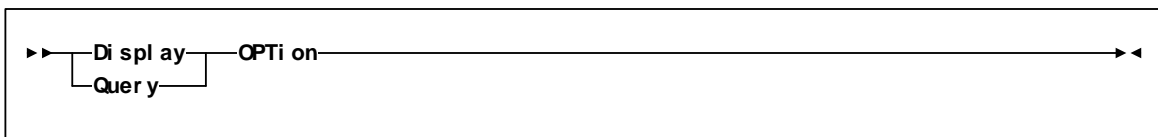

Display PATH

Interfaces:

Console or PARMLIB
UII: No

Subsystem Requirements:

Active HSC/VTCS

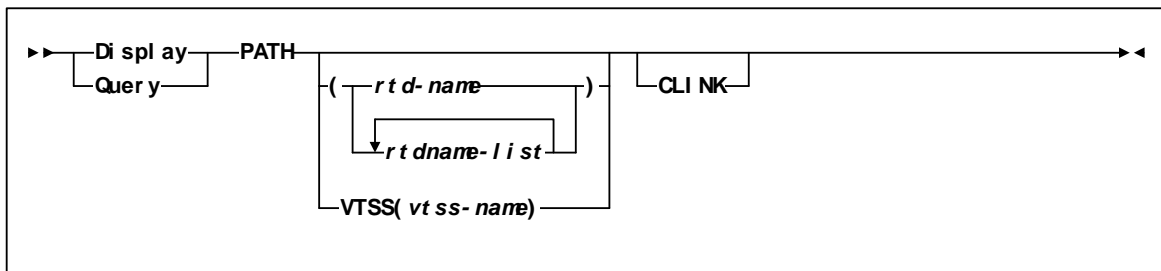

Display Queue

Interfaces:

Console or utility
UII: Yes

Subsystem Requirements:

Active HSC/VTCS

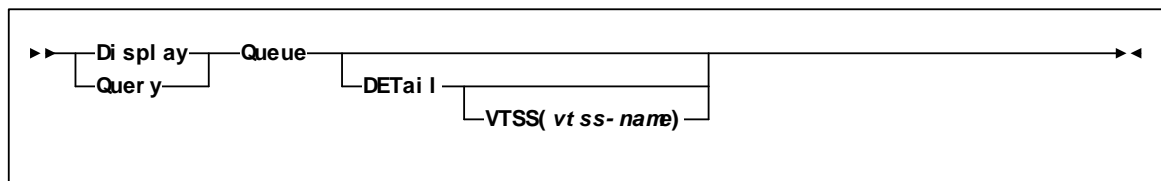

Display REPLICAT

Interfaces:

Console or utility
 UUI: Yes

Subsystem Requirements:

Active HSC/VTCS

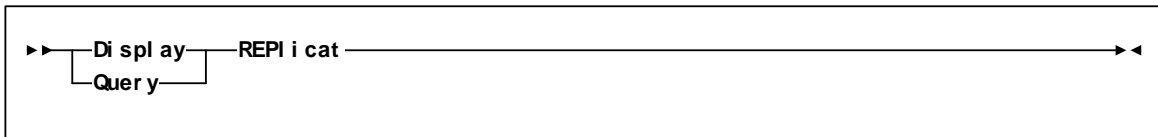

Display Requests

Interfaces:

Console or PARMLIB
 UUI: Yes

Subsystem Requirements:

Active HSC at BASE or FULL service level

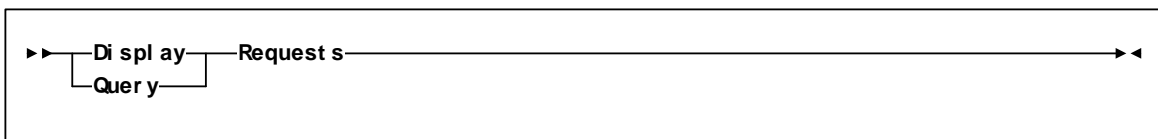

Display RTD

Interfaces:

Console or utility
UII: Yes

Subsystem Requirements:

Active HSC/VTCS

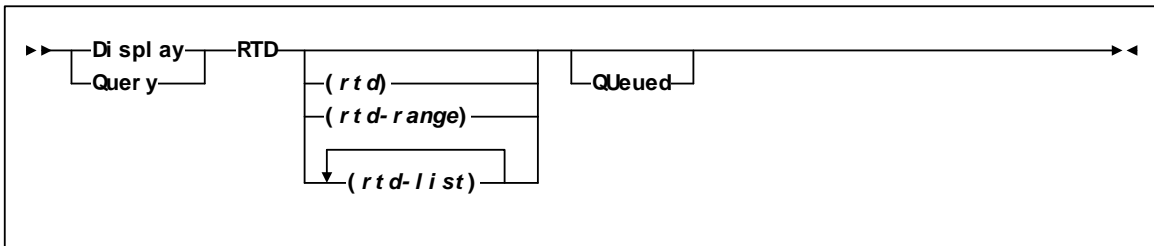

Display SCRatch

Interfaces:

Console or utility
UII: Yes

Subsystem Requirements:

Active HSC at BASE or FULL service level

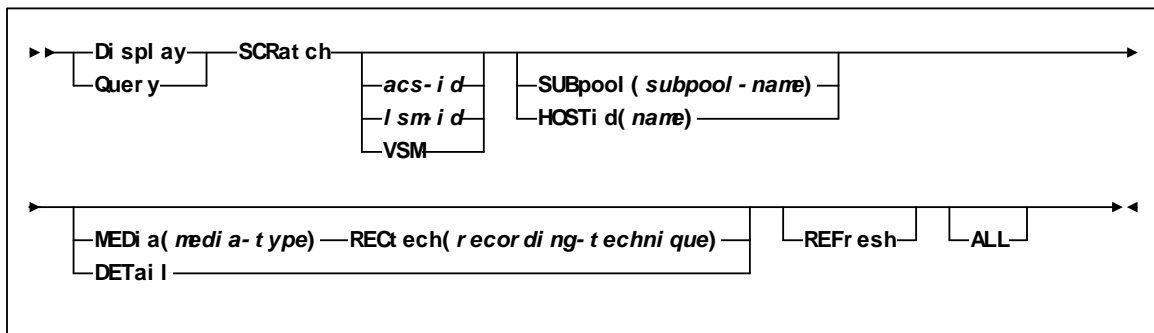

Display SRVlev

Interfaces:

Console or utility
UII: Yes

Subsystem Requirements:

Active HSC at FULL service level

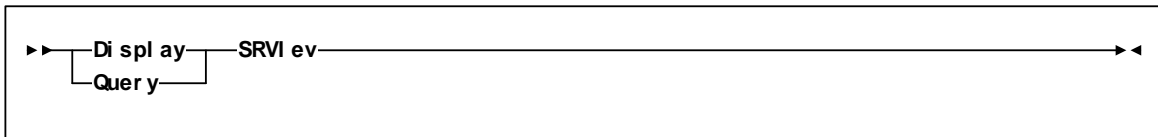

Display Status

Interfaces:

Console or PARMLIB
UII: No

Subsystem Requirements:

Active HSC at BASE or FULL service level

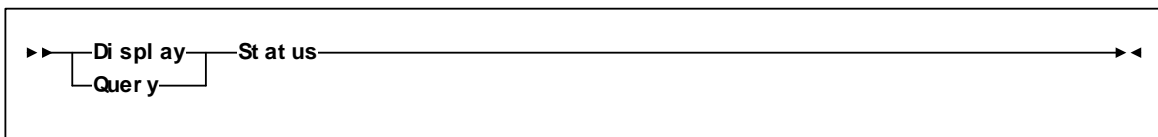

Display STORCLas

Interfaces:

Console or utility
 UUI: Yes

Subsystem Requirements:

Active HSC/VTCS

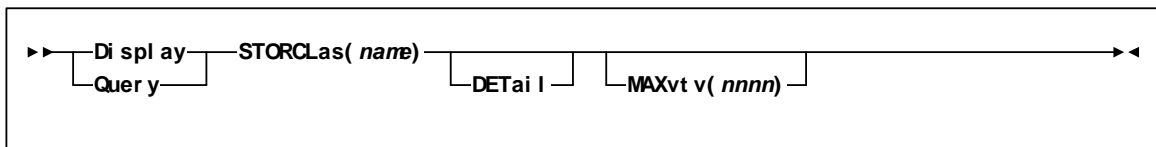

Display STORMNgr

Interfaces:

Console or PARMLIB
 UUI: No

Subsystem Requirements:

Active HSC/VTCS

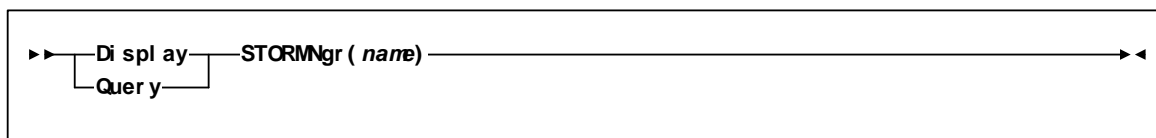

Display TASKs

Interfaces:

Console or utility
UII: Yes

Subsystem Requirements:

Active HSC at BASE or FULL service level

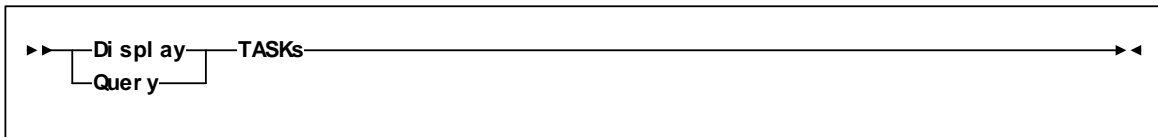

Display THReshld

Interfaces:

Console or utility
UII: Yes

Subsystem Requirements:

Active HSC at BASE or FULL service level

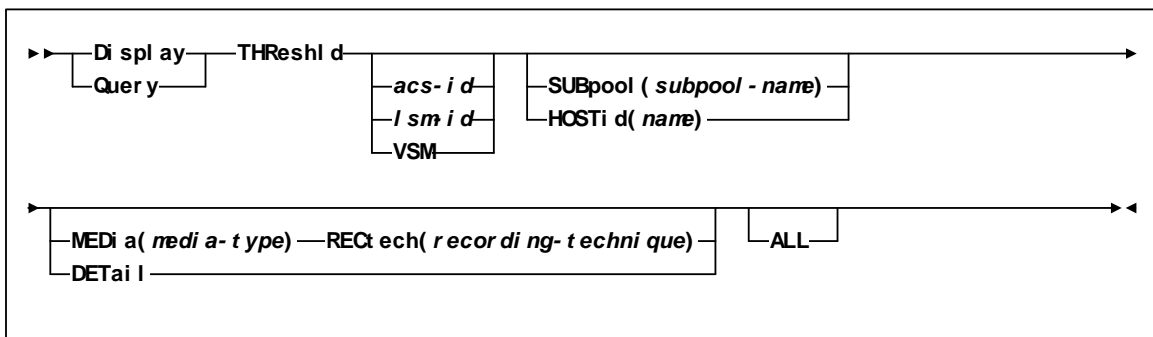

Display Volser

Interfaces:

Console or utility
 UUI: Yes

Subsystem Requirements:

Active HSC at BASE or FULL service level

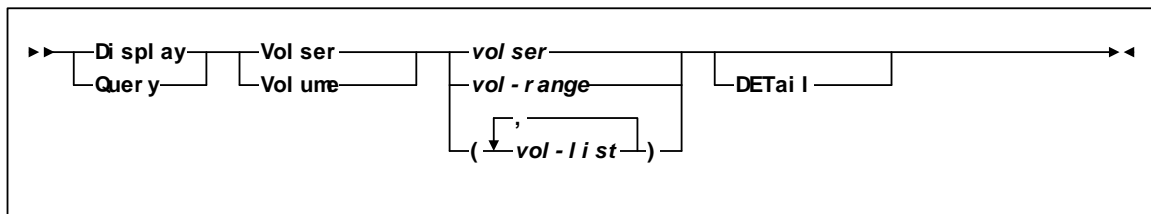

Display VOLume_Info

Interfaces:

Console or utility
 UUI: Yes

Subsystem Requirements:

Active HSC/VTCS

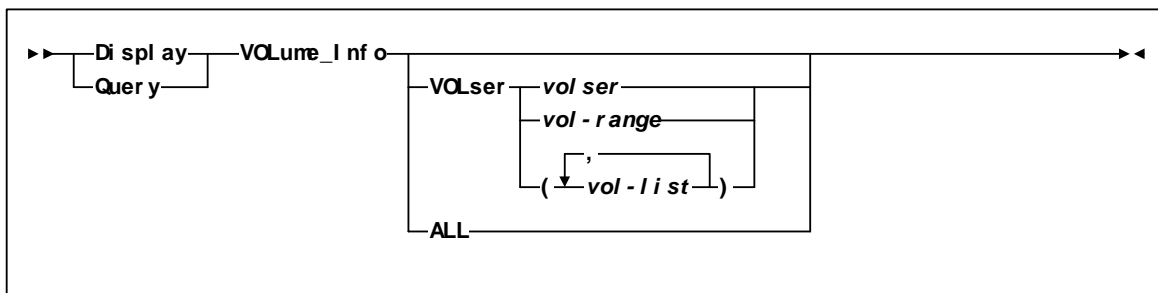

Display VSCRatch

Interfaces:

Console or utility
UII: Yes

Subsystem Requirements:

Active HSC/VTCS

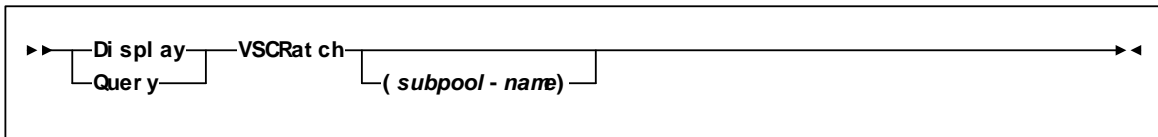

Display VTD

Interfaces:

Console or utility
UII: Yes

Subsystem Requirements:

Active HSC/VTCS

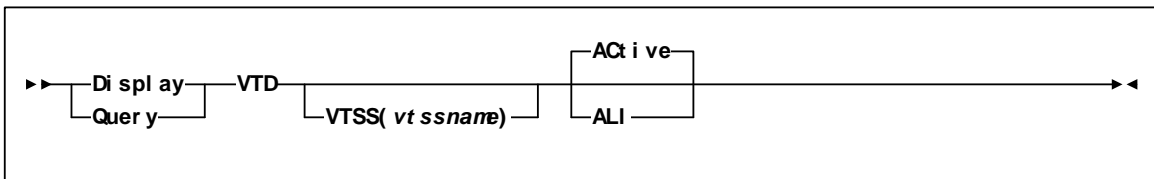

Display VTSS

Interfaces:

Console or utility
 UUI: Yes

Subsystem Requirements:

Active HSC/VTCS

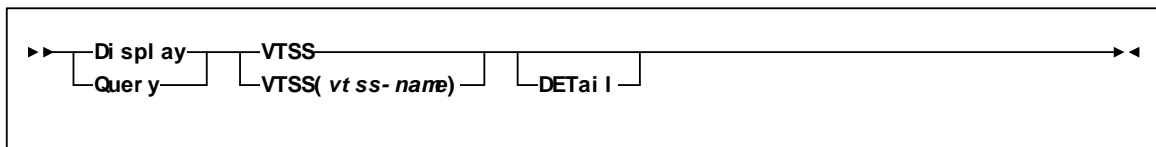

Display VTV

Interfaces:

Console or utility
 UUI: Yes

Subsystem Requirements:

Active HSC/VTCS

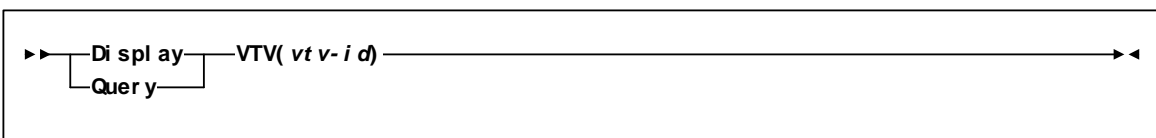

DRAin

Interfaces:

Console or PARMLIB only
UII: No

Subsystem Requirements:

Active HSC at FULL service level

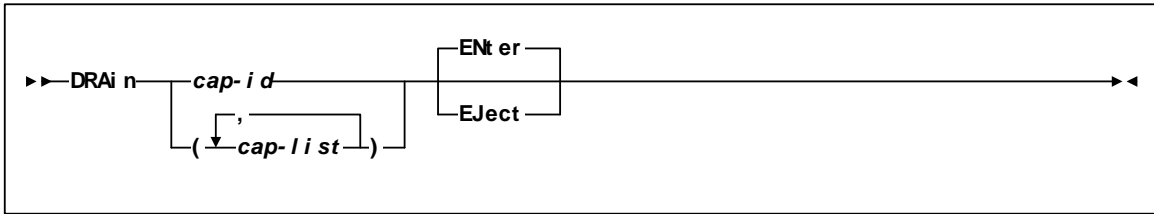

DRCHKPT

Interfaces:

SLUADMIN utility only
 UUI: No

Subsystem Requirements:

Active HSC/VTCS at FULL service level

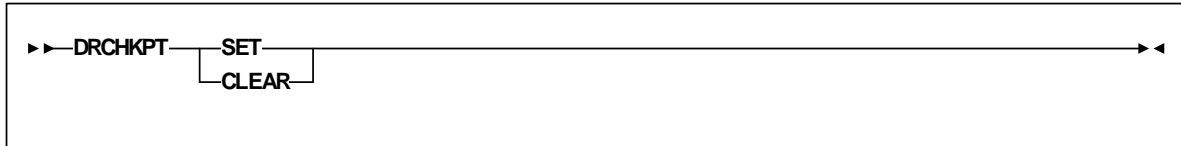

DRMONitr

Interfaces:

SLUADMIN utility only
 UUI: No

Subsystem Requirements:

Active HSC/VTCS at FULL service level

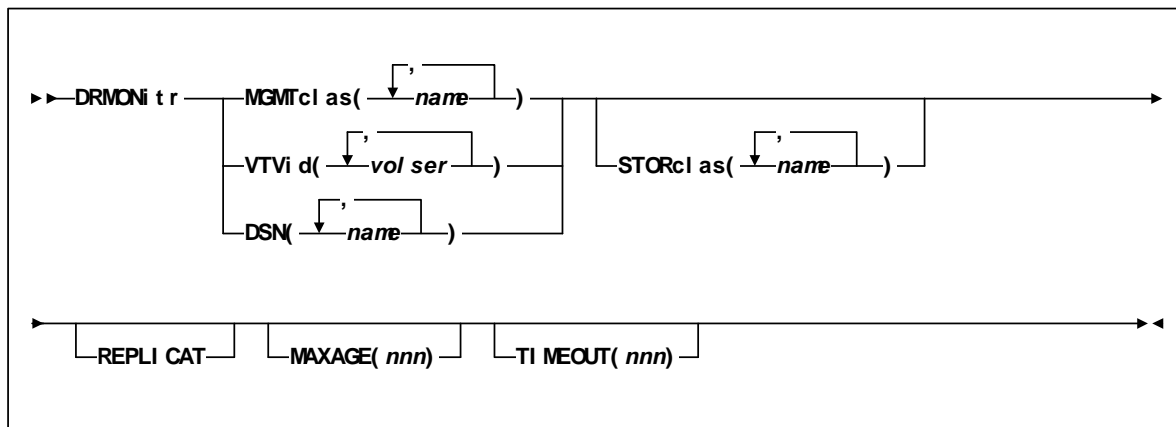

DRTEST CREATE

Interfaces:

SLUADMIN utility only
 UUI: No

Subsystem Requirements:

Active HSC not required

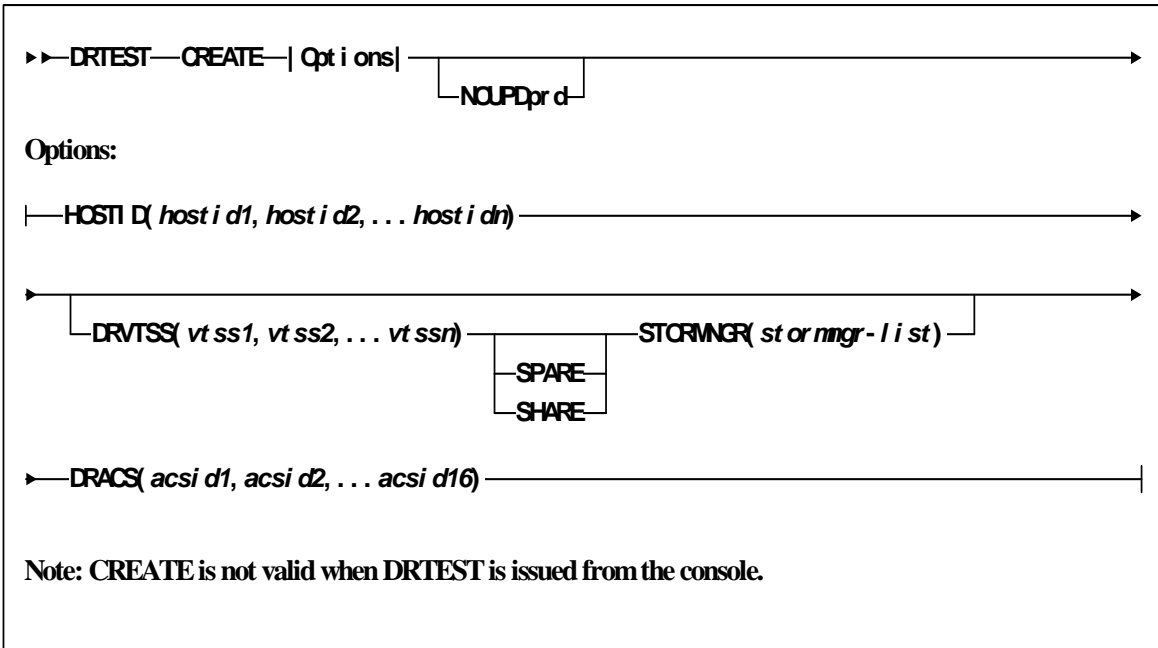

DRTEST PRIMEprd

Interfaces:

SLUADMIN utility only
 UUI: No

Subsystem Requirements:

Active HSC not required

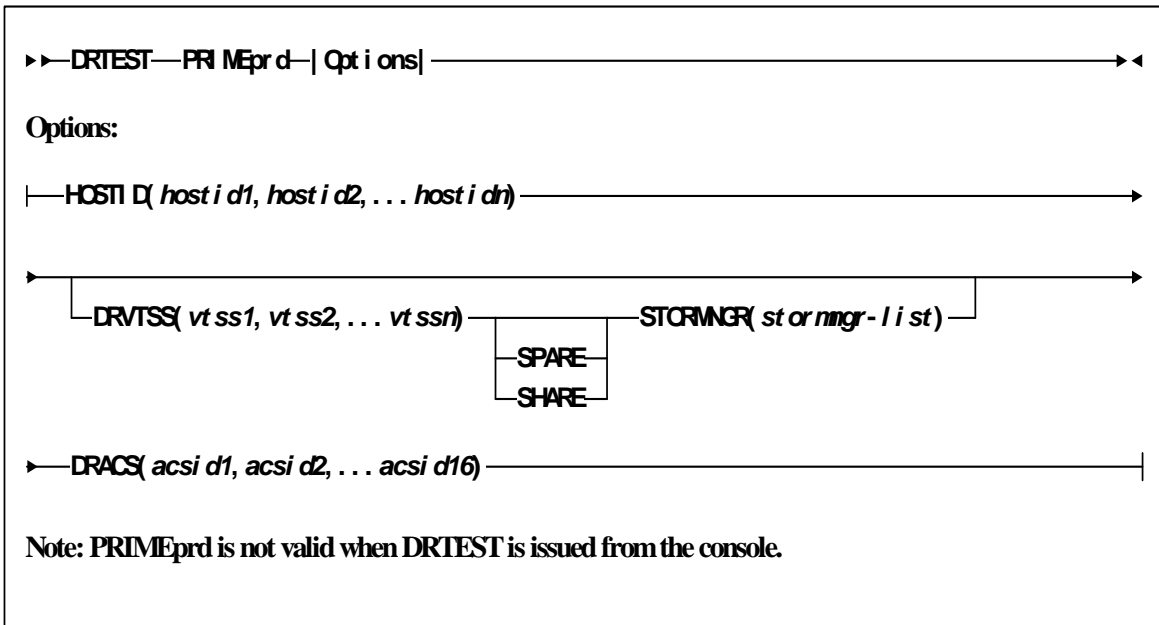

DRTEST RESET

Interfaces:

SLUADMIN utility only
UII: No

Subsystem Requirements:

Active HSC not required

▶▶ DRTEST—RESET —————▶▶

Note: RESET is not valid when DRTEST is issued from the console.

DRTEST START

Interfaces:

Console or utility
UII: Yes

Subsystem Requirements:

Active HSC at FULL service level

▶▶ DRTEST—START —————▶▶

DRTEST STOP

Interfaces:

Console or utility
UII: Yes

Subsystem Requirements:

Active HSC at FULL service level

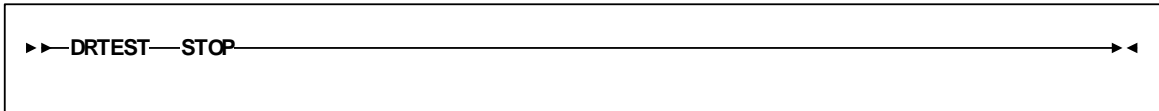

EEXPORT

Interfaces:

Console or utility
UUI: Yes

Subsystem Requirements:

Active HSC not required

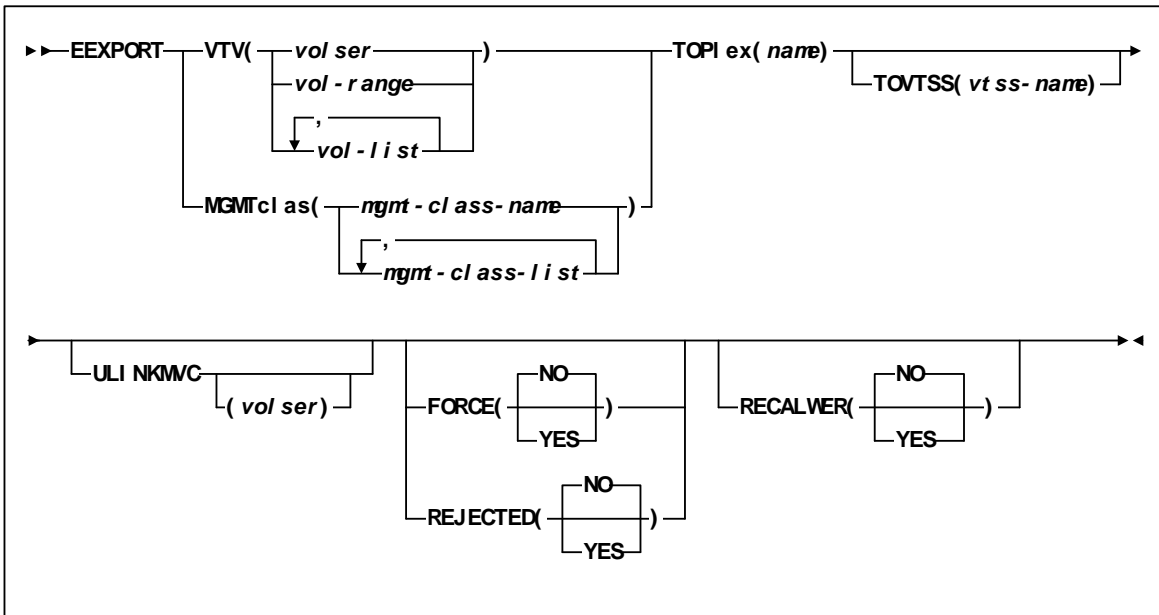

Eject

Interfaces:

Console or utility
 UUI: Yes

Subsystem Requirements:

Active HSC at FULL service level

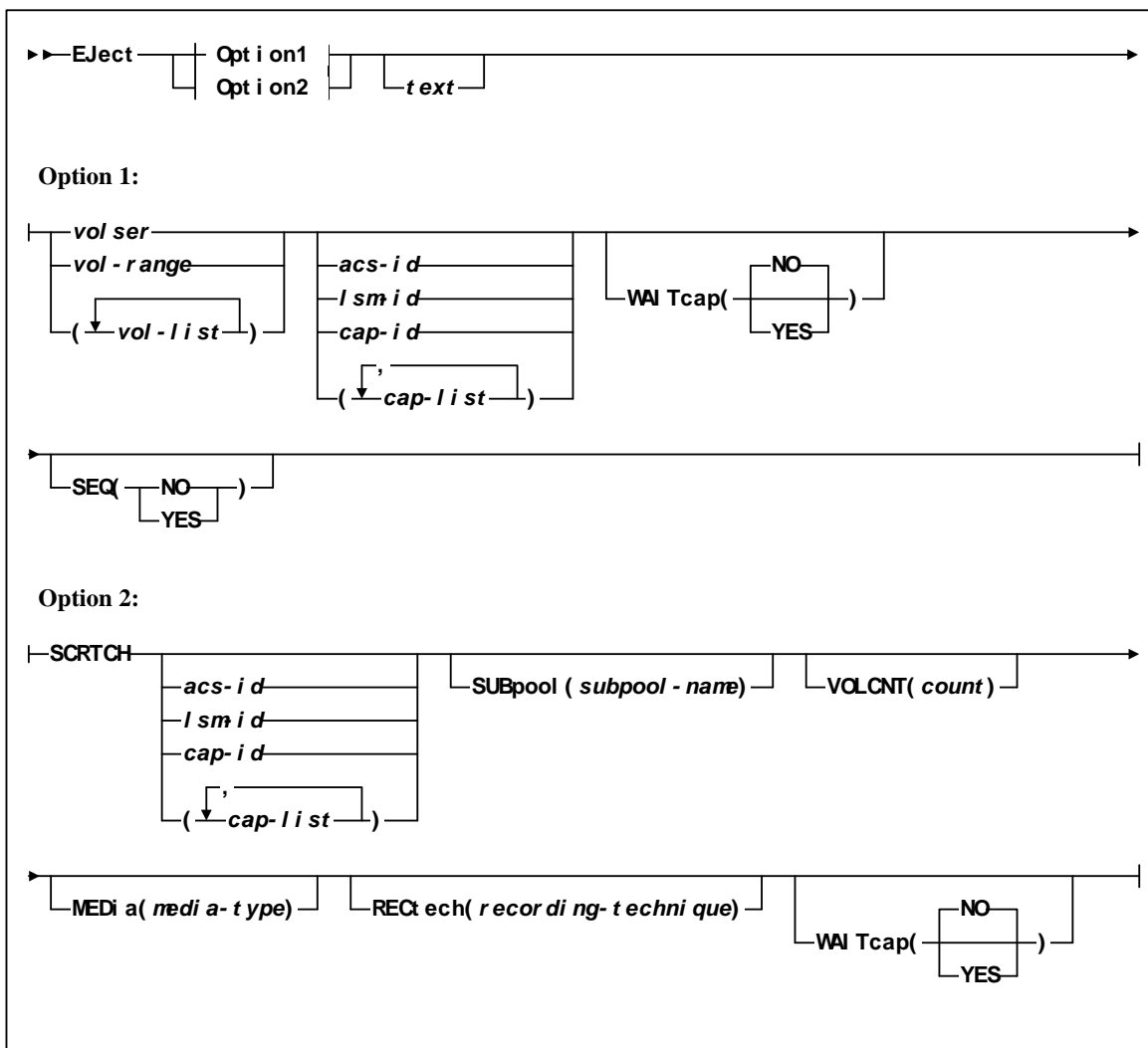

ENter

Interfaces:

Console or utility
 UUI: Yes

Subsystem Requirements:

Active HSC at FULL service level

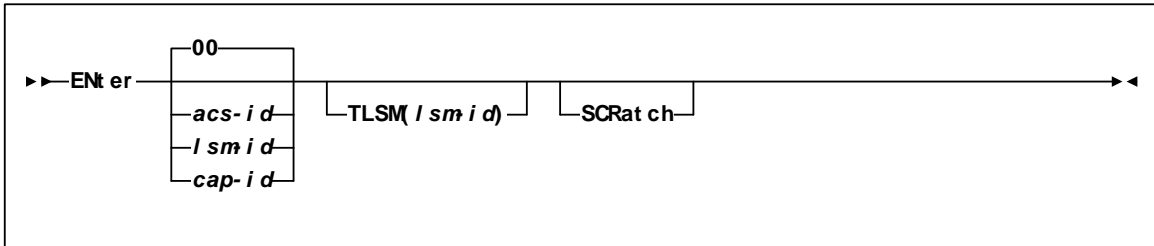

EXECPar m

Interfaces:

PARMLIB only
 UUI: No

Subsystem Requirements:

None

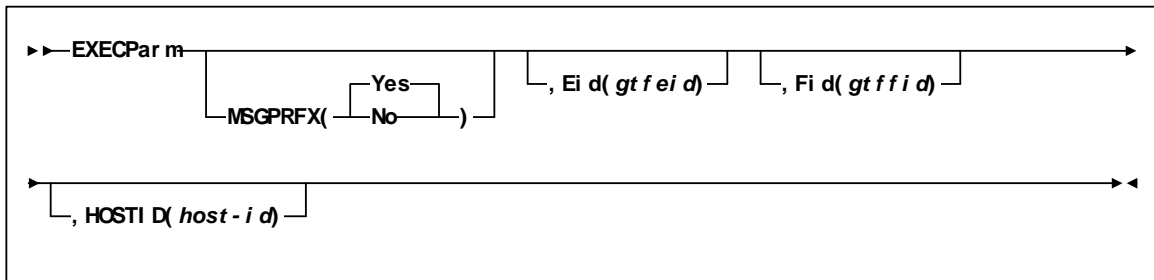

EXPORT

Interfaces:

Utility only

UUI: Yes

Subsystem Requirements:

- Active HSC/VTCS at FULL service level required when specifying the VTV, MGMTCLAS, or STORCLAS parameter.
- Active HSC/VTCS not required when specifying the MVC parameter.

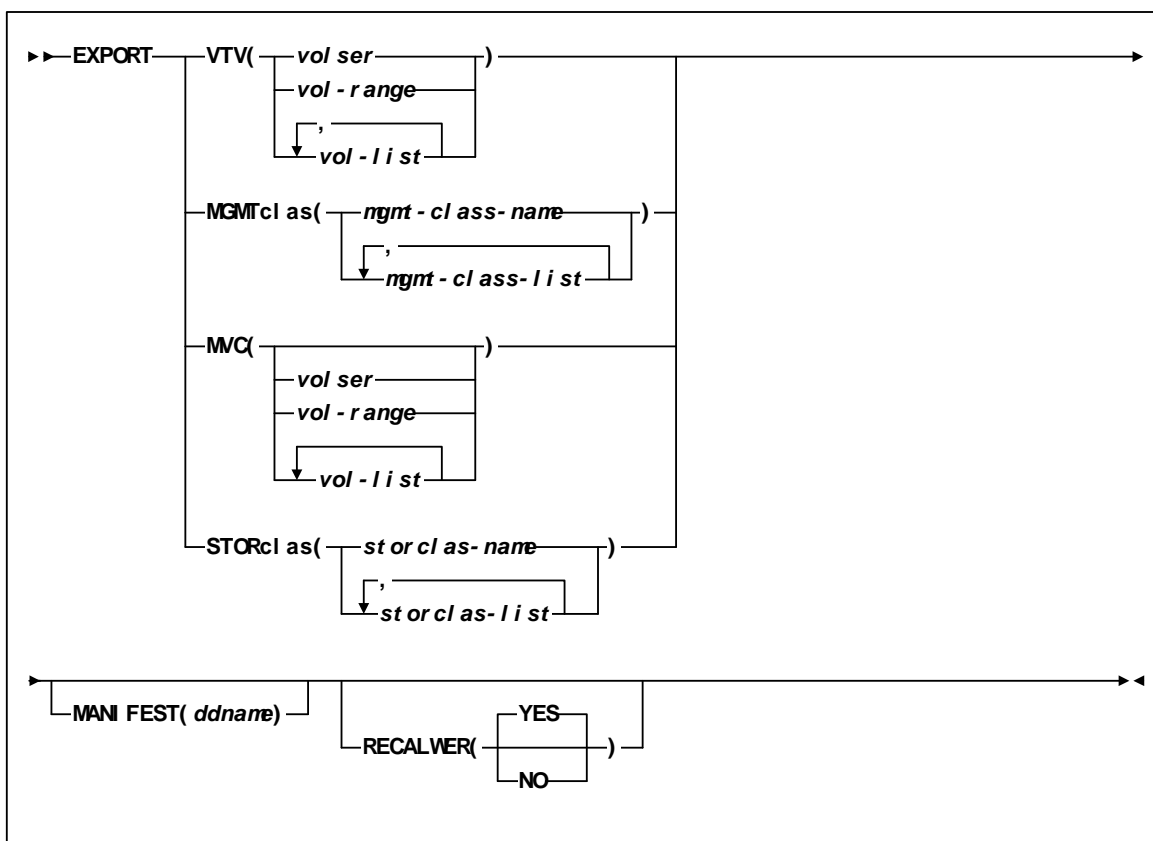

FMTLOG

Interfaces:

SLUADMIN utility only
UII: No

Subsystem Requirements:

Active HSC not required

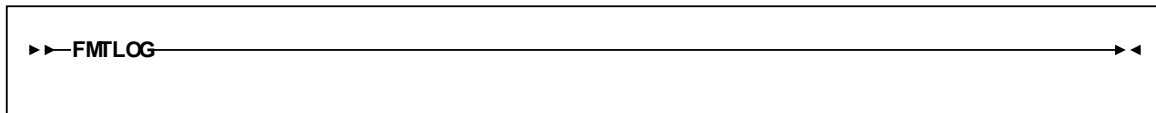

IMPORT

Interfaces:

Utility only
 UUI: Yes

Subsystem Requirements:

Active HSC/VTCS not required

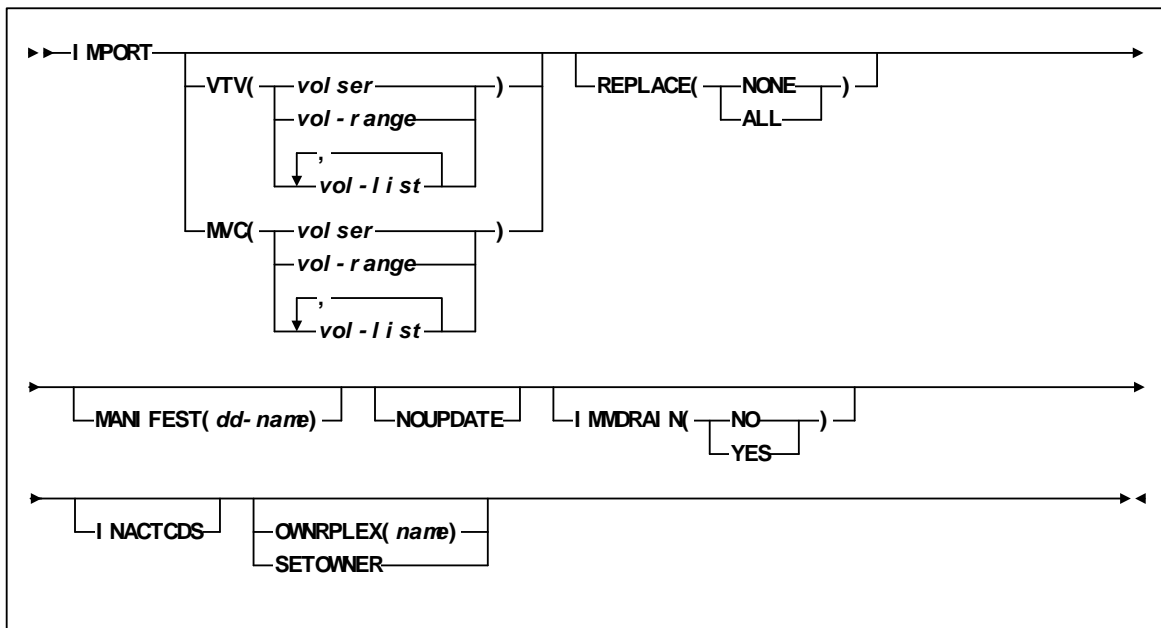

INITialize

Interfaces:

SLUADMIN utility only
 UUI: No

Subsystem Requirements:

Active HSC at FULL service level

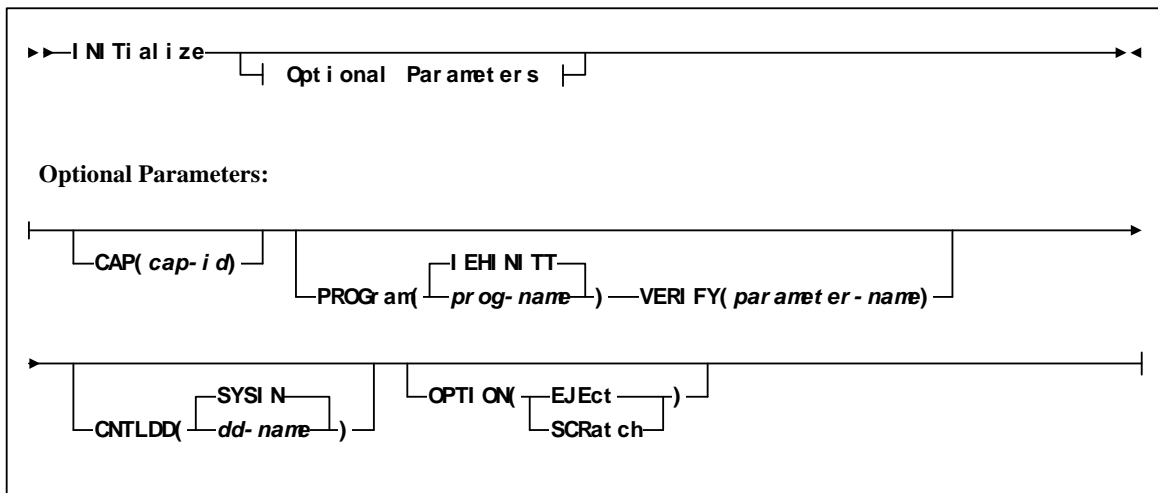

INVENTORY

Interfaces:

Utility only
 UUI: Yes

Subsystem Requirements:

Active HSC/VTCS

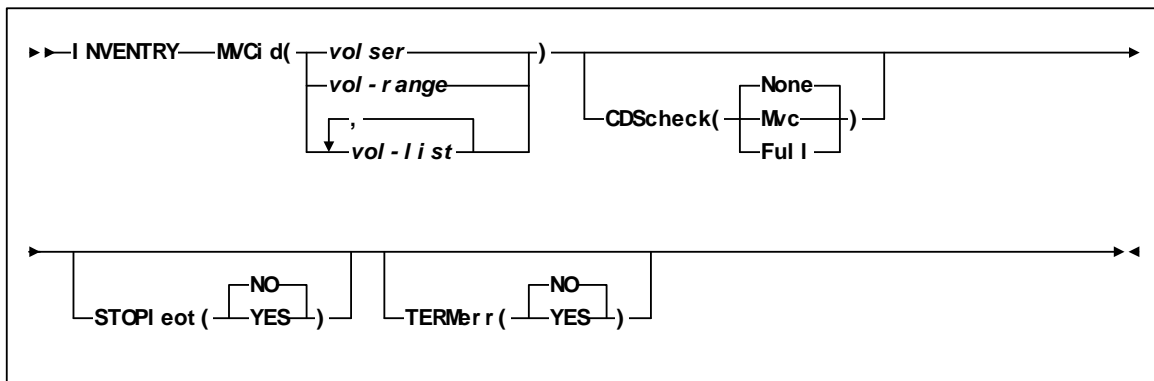

LIBGen

Interfaces:

SLUADMIN utility only
 UUI: No

Subsystem Requirements:

Active HSC not required

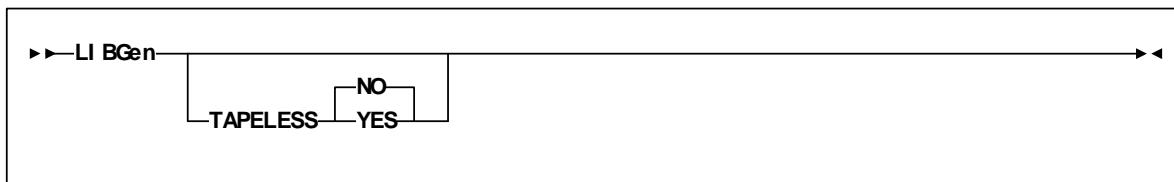

LMUPDEF

Interfaces:

Console or PARMLIB
 UUI: No

Subsystem Requirements:

Active HSC at BASE or FULL service level

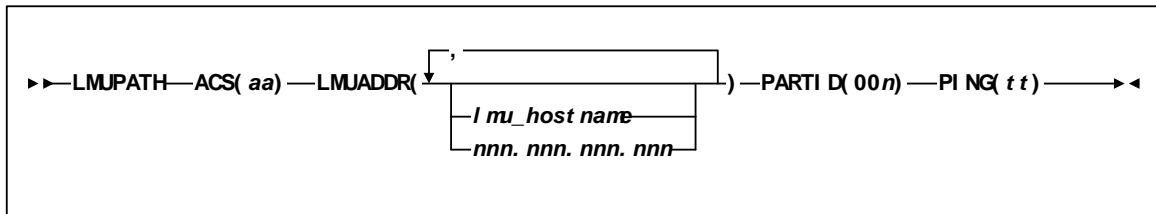

LMUPATH Control Statement

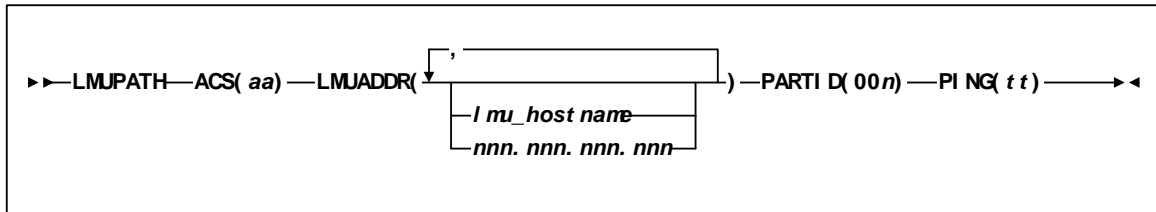

LOGUTIL

Interfaces:

SLUADMIN utility only
 UUI: Yes

Subsystem Requirements:

Active HSC not required

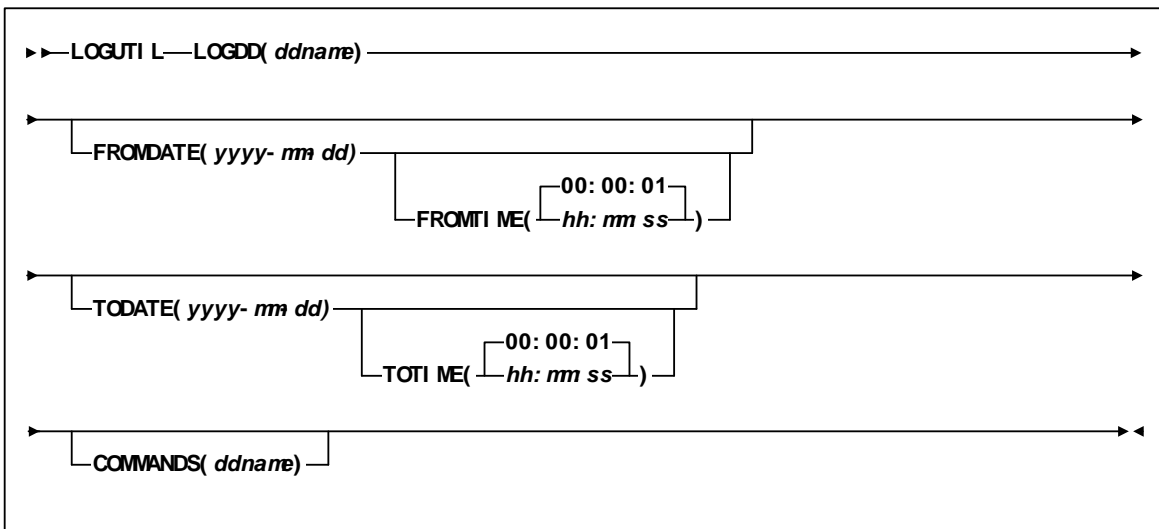

LOGUTIL FOR_LOSTMVC Statement

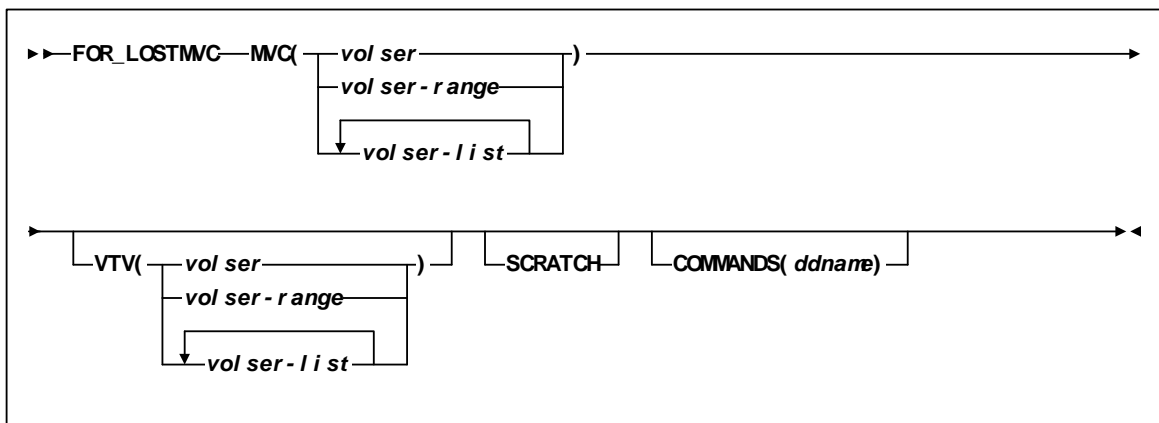

LOGUTIL GENAUDIT Statement

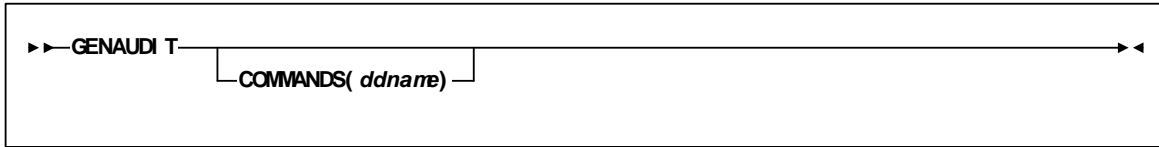

LOGUTIL LOCATE_VTV

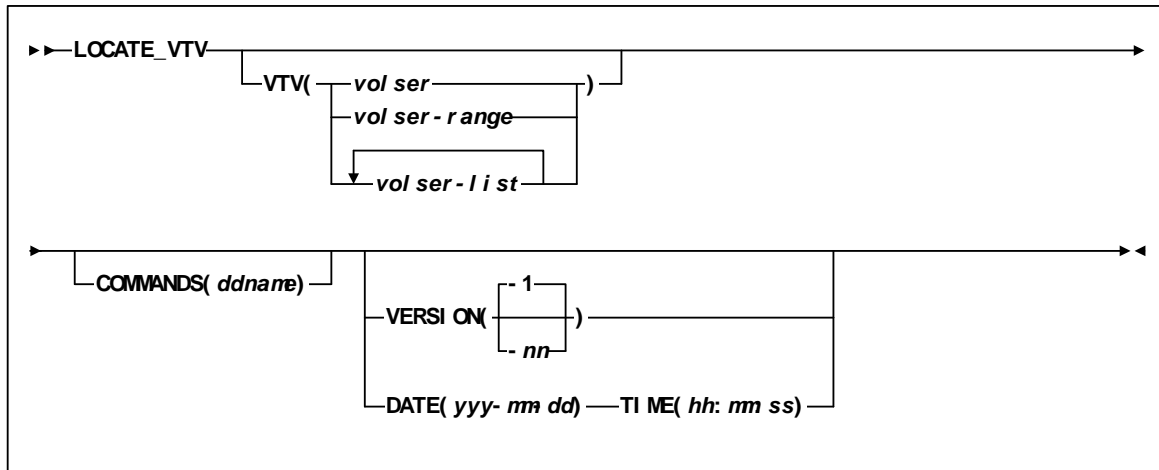

LOGUTIL UNDELETE Statement

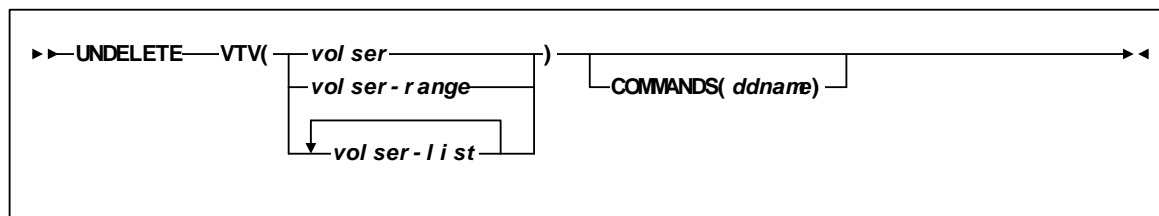

MEDVERfy

Interfaces:

SLUADMIN utility only
 UUI: No

Subsystem Requirements:

Active HSC/VTCS

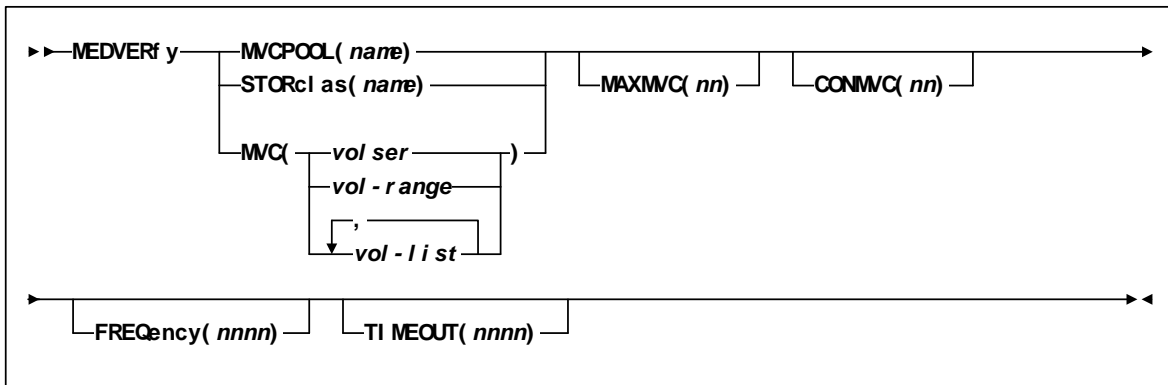

MERGEcds

Interfaces:

SLUADMIN utility only
 UUI: No

Subsystem Requirements:

Active HSC at BASE service level only

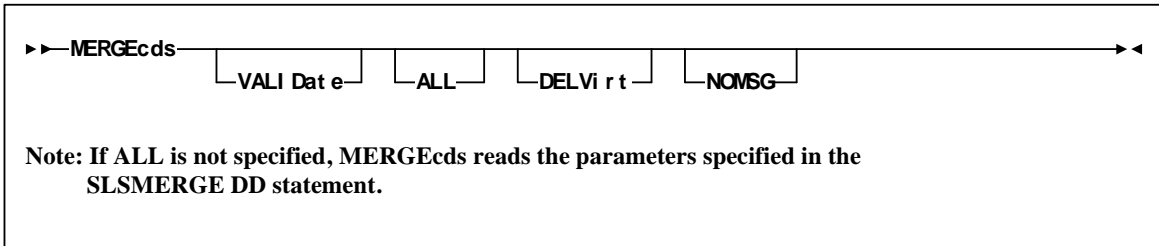

SLSMERGE Control Statement

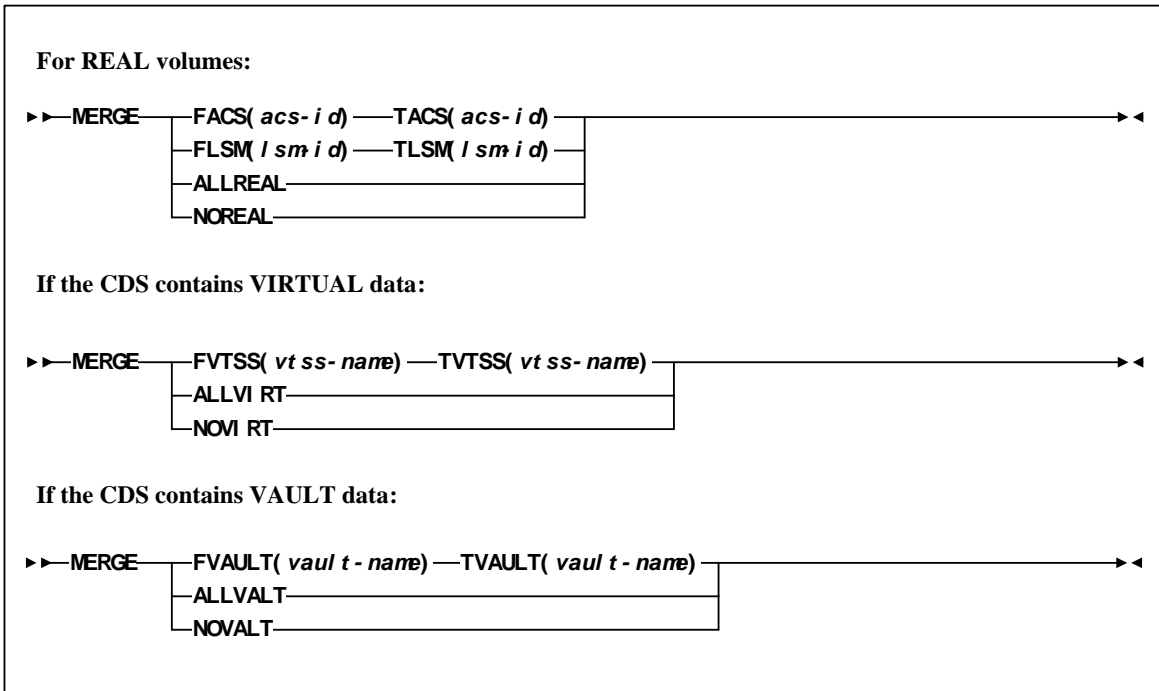

MERGMFST

Interfaces:

Utility only
UUI: Yes

Subsystem Requirements:

Active HSC not required

▶▶MERGMFST—MERGEI N(*mani f i n*)—MERGEOUT(*mani f out*)◀◀

METAdata

Interfaces:

Utility only
 UUI: Yes

Subsystem Requirements:

Active HSC/VTCS

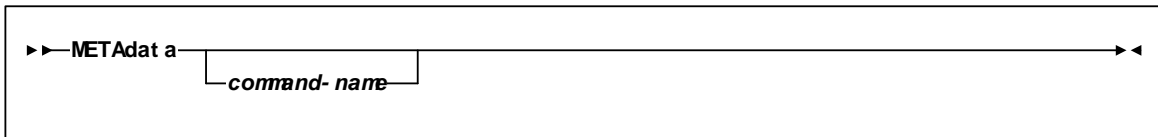

MGMTDEF

Interfaces:

Console or PARMLIB only
 UUI: No

Subsystem Requirements:

Active HSC at BASE or FULL service level

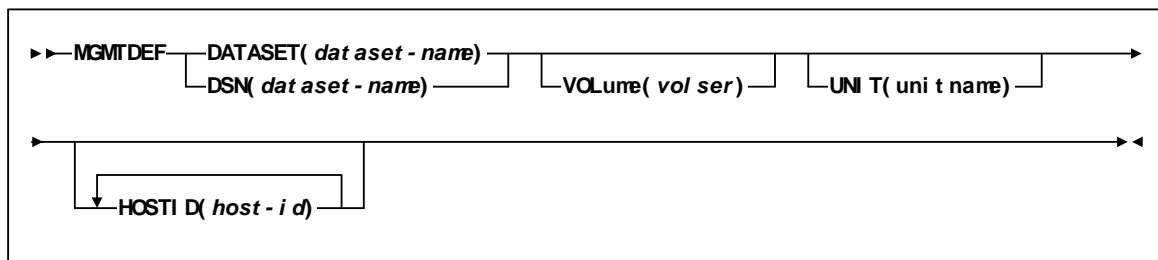

MGMTclas Control Statement

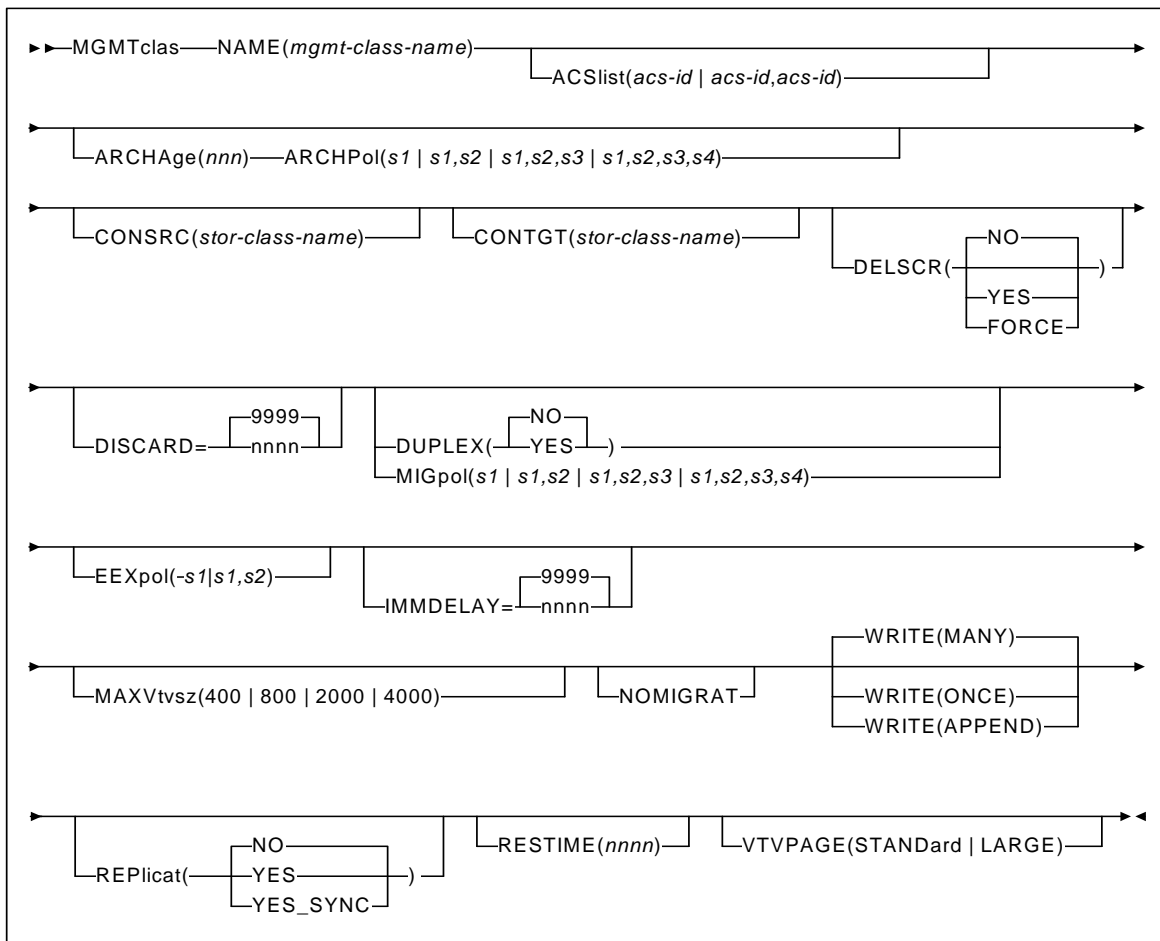

MIGRSEL Control Statement

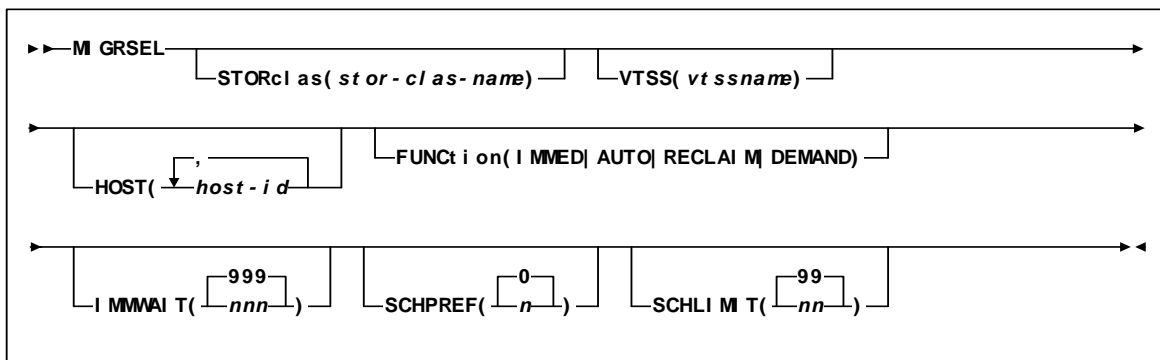

MIGRVTV Control Statement

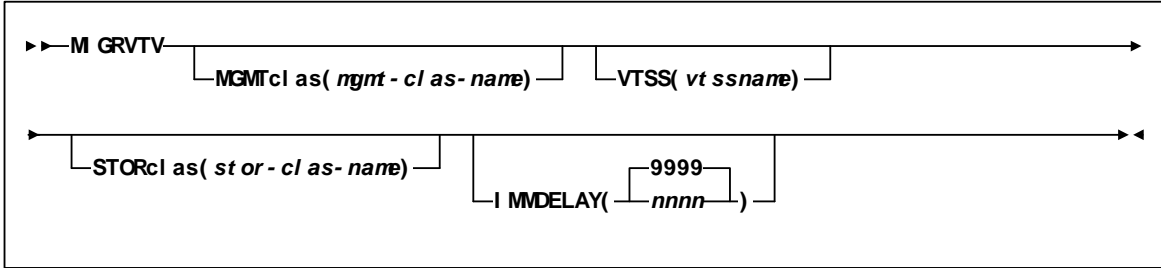

MVCATTR Control Statement

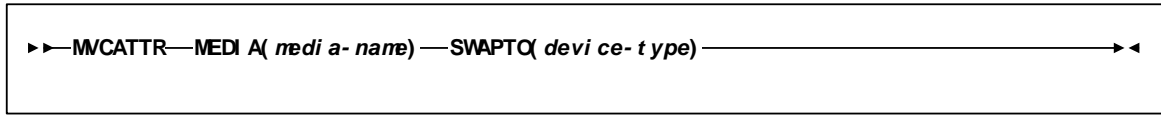

STORCLAS Control Statement

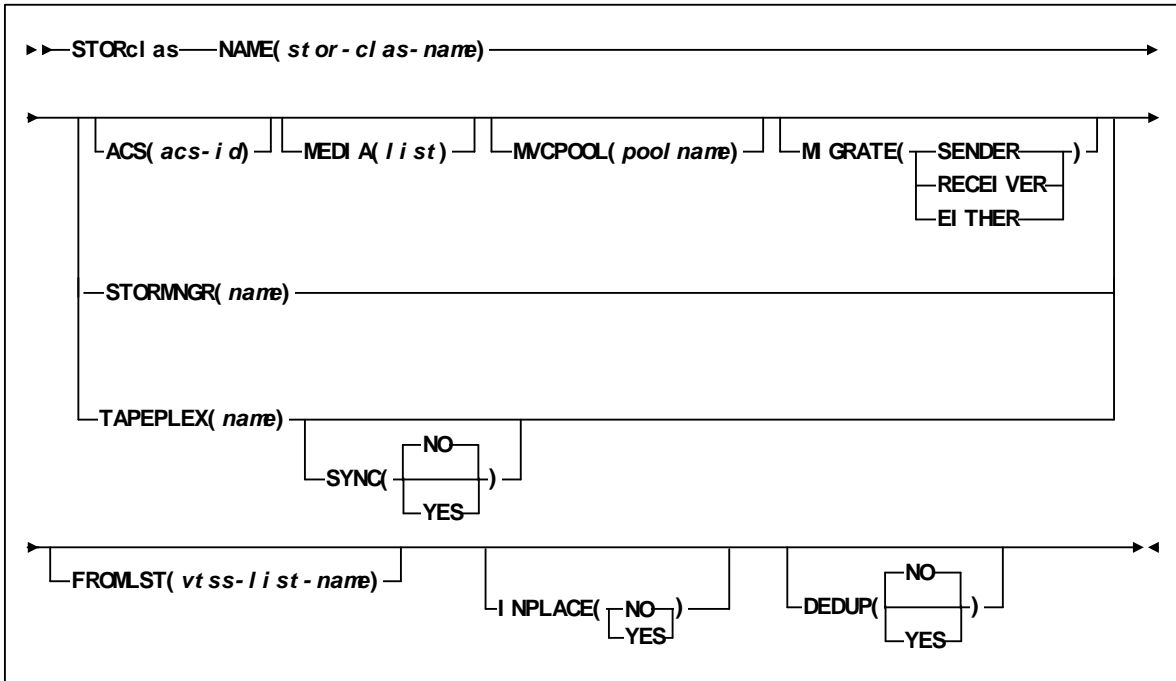

STORLST Control Statement

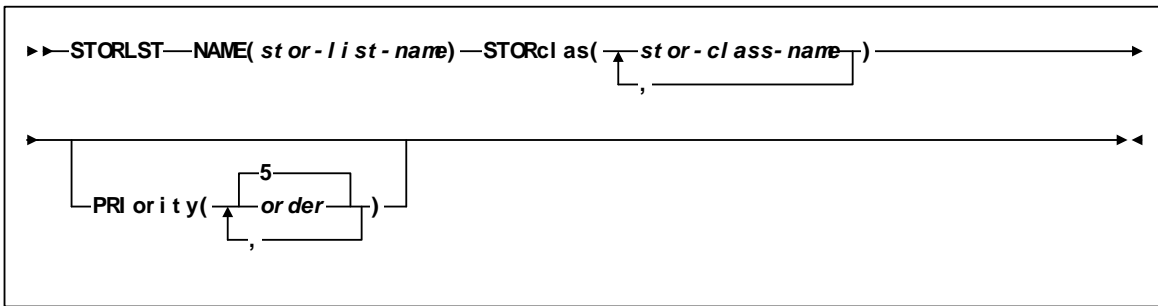

STORSEL Control Statement

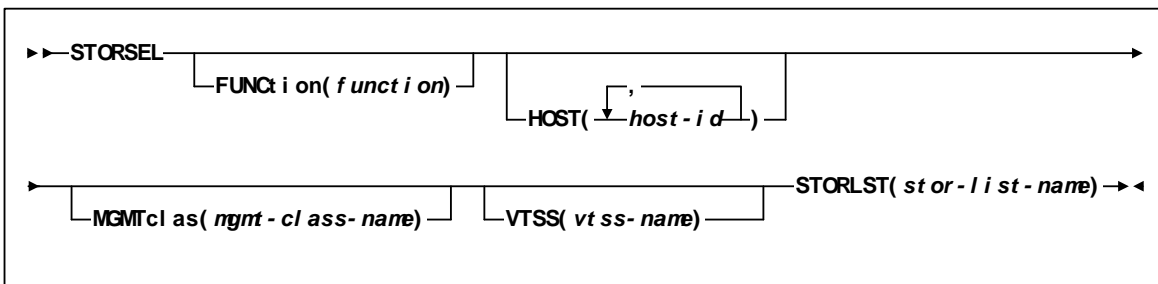

VTSSLST Control Statement

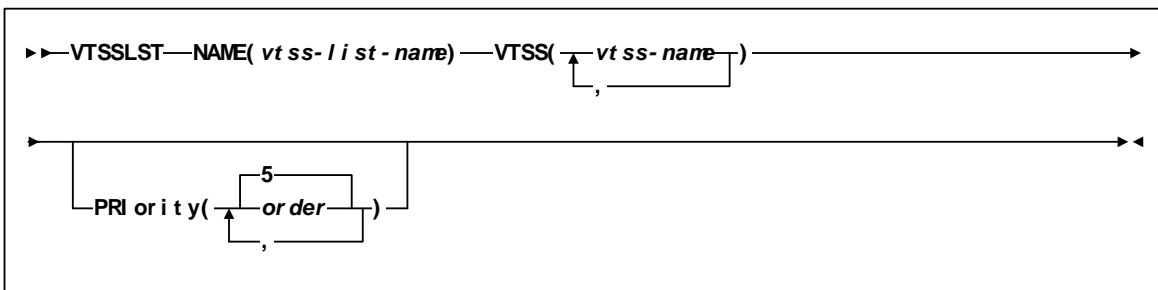

VTSSSEL Control Statement

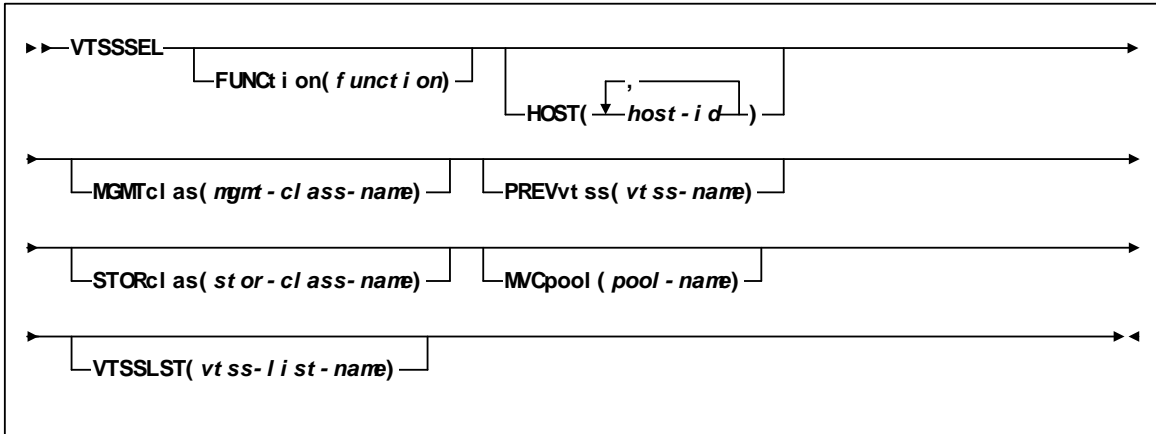

MIGrate

Interfaces:

Console or utility
 UUI: Yes

Subsystem Requirements:

Active HSC/VTCS

Format 1

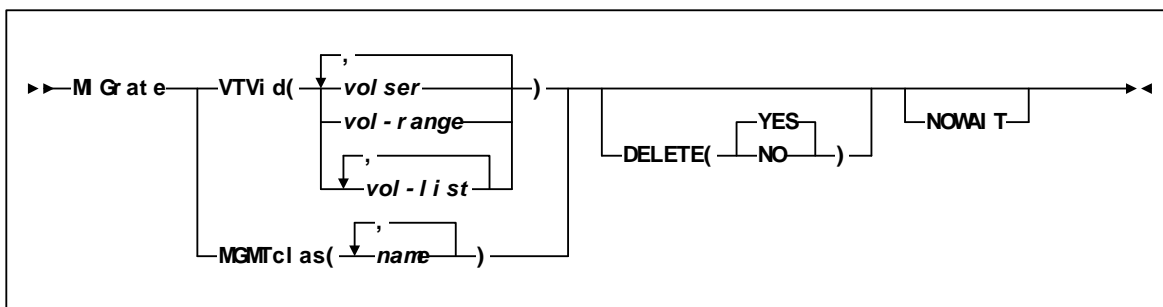

Format 2

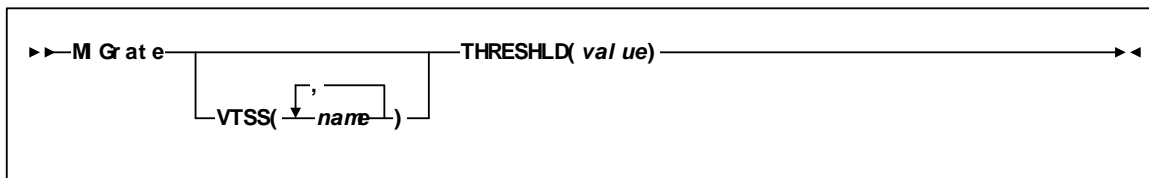

MNTD

Interfaces:

Console or PARMLIB only
 UUI: No

Subsystem Requirements:

Active HSC at FULL service level

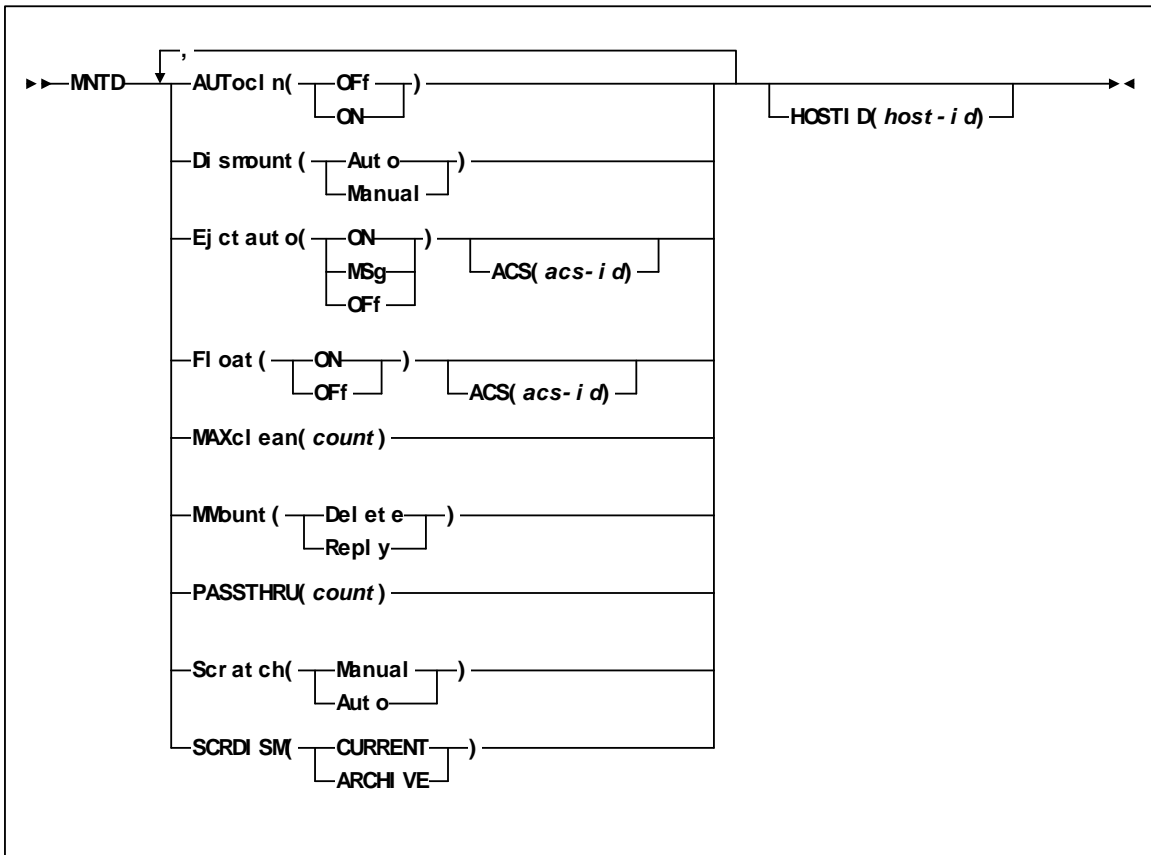

MODify

Interfaces:

Console or PARMLIB only
 UUI: No

Subsystem Requirements:

Active HSC at FULL service level

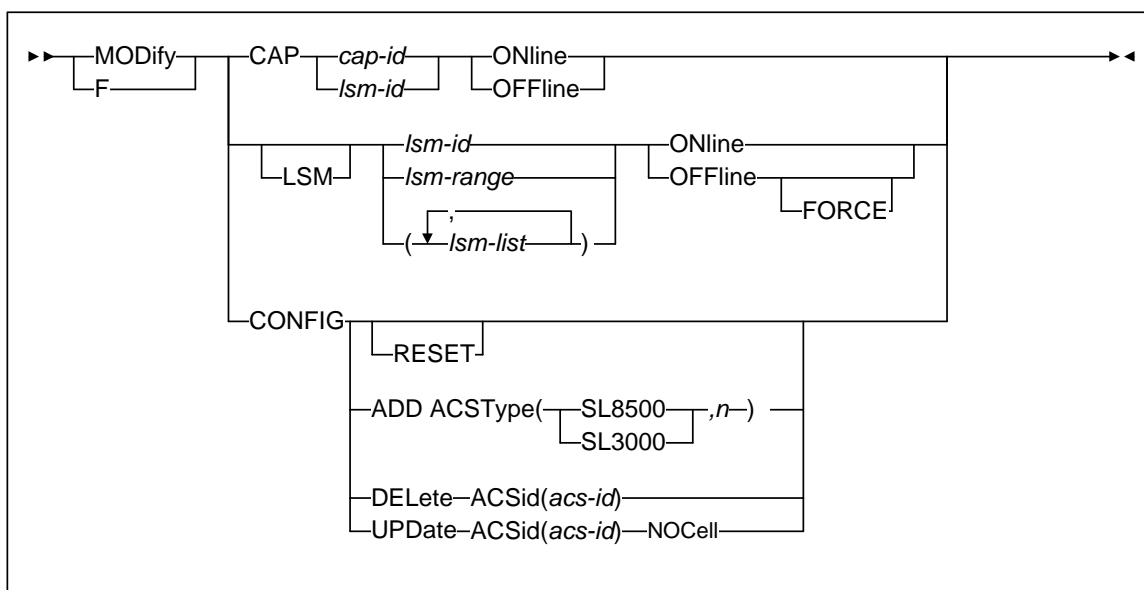

Mount

Interfaces:

Console or utility
UUI: Yes

Subsystem Requirements:

Active HSC at FULL service level

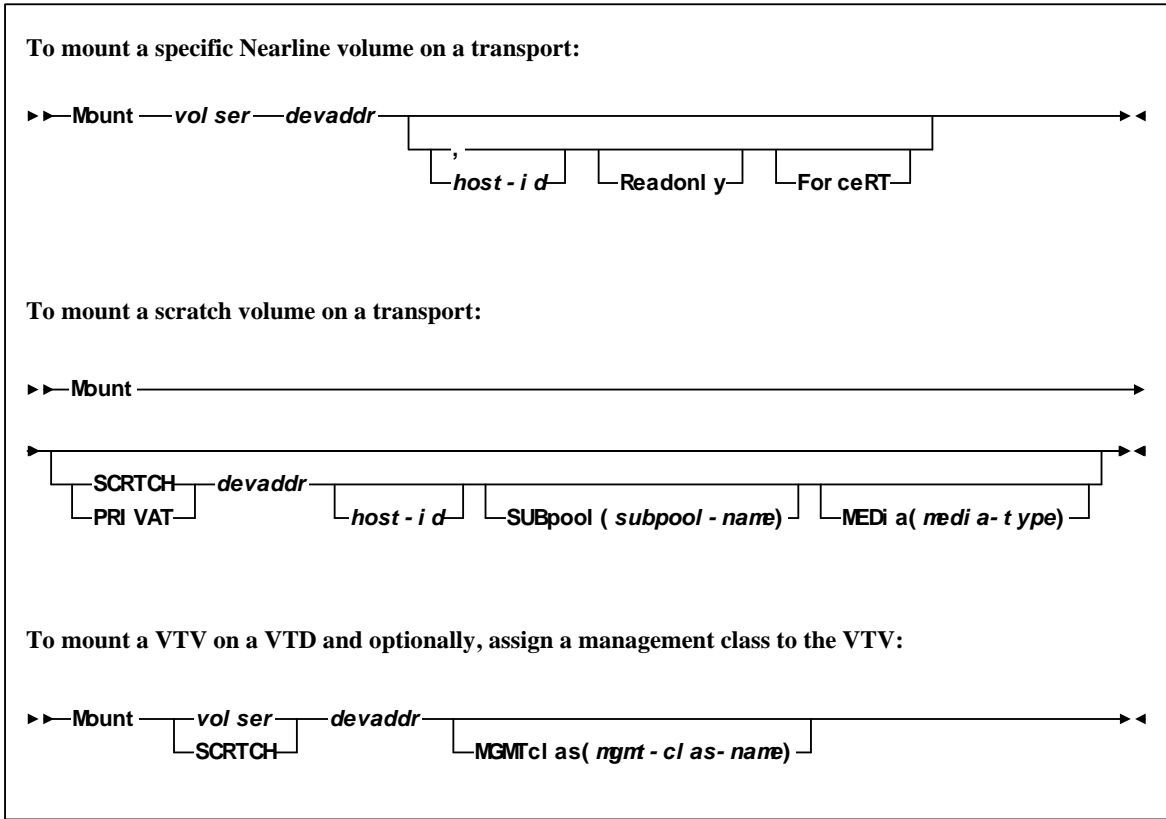

MOVE

Interfaces:

Console or utility
 UUI: Yes

Subsystem Requirements:

Active HSC at FULL service level

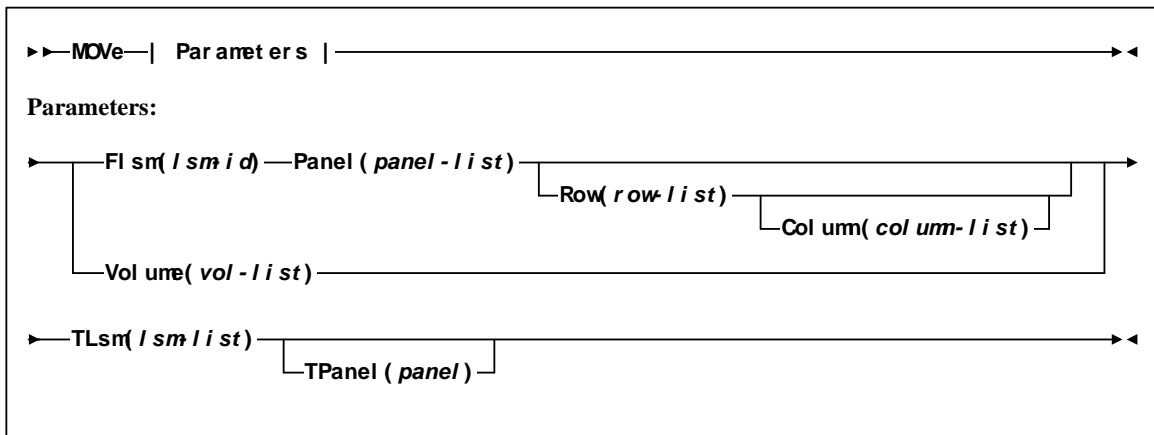

MVCDRain

Interfaces:

Console or utility
 UUI: Yes

Subsystem Requirements:

Active HSC/VTCS

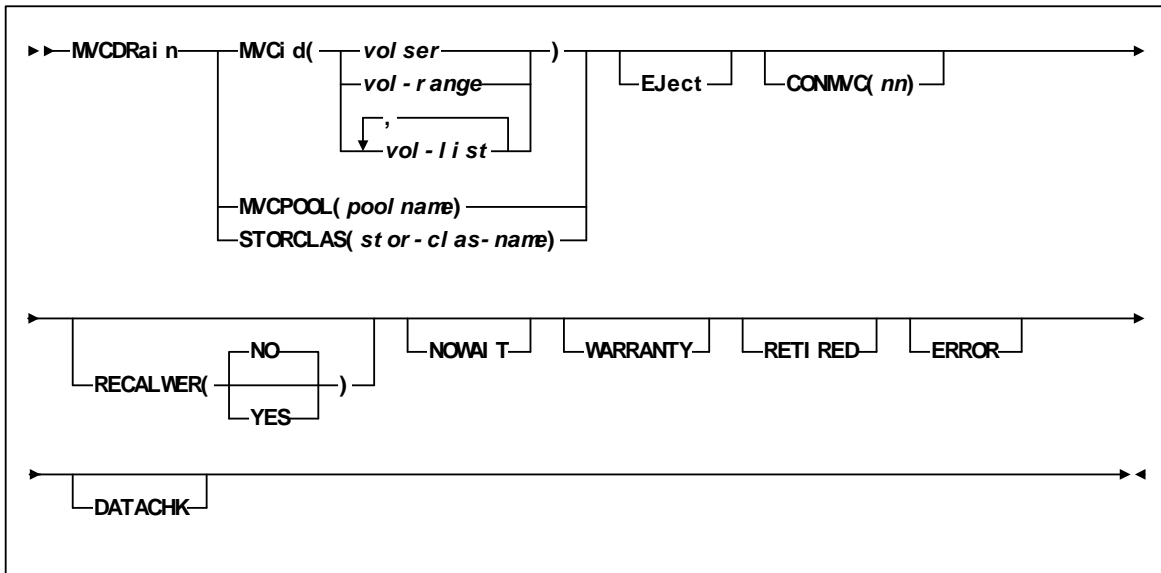

MVCMAINT

Interfaces:

Utility only
 UUI: Yes

Subsystem Requirements:

- Active HSC/VTCS required if RENVTSS is specified
- Can run in batch-only mode when there are no hosts active (on any LPAR) using the CDS that is to be updated

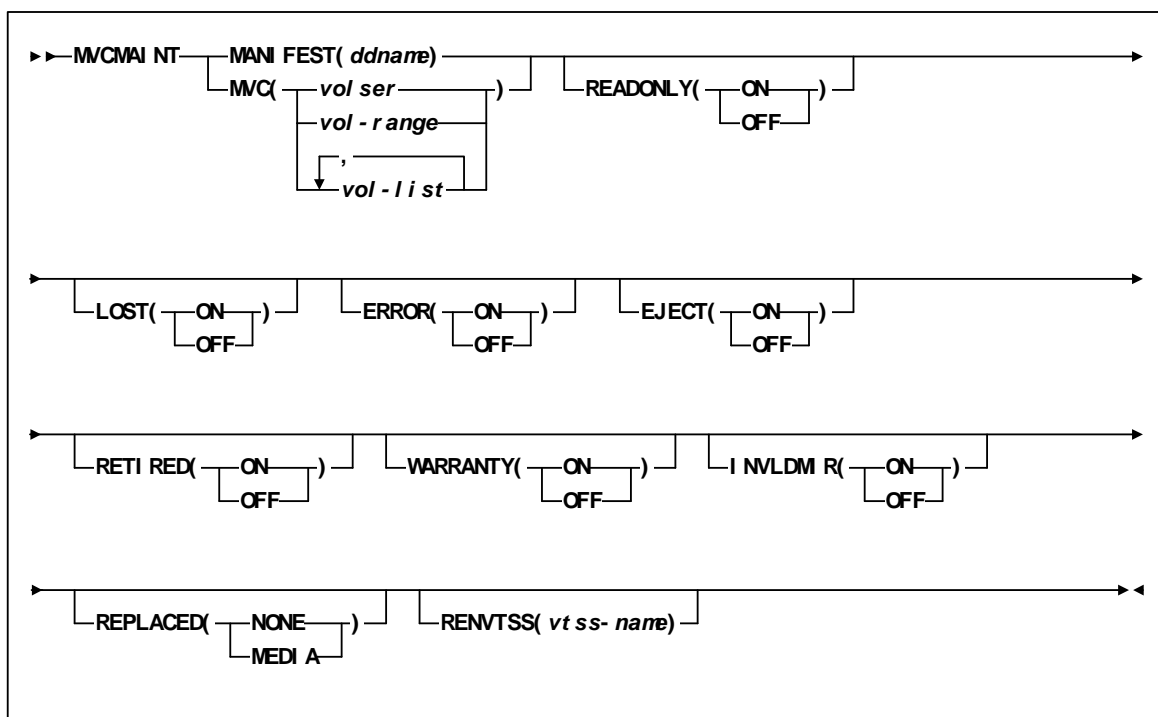

MVCPLRPT

Interfaces:

Utility only
 UUI: Yes

Subsystem Requirements:

Active HSC not required

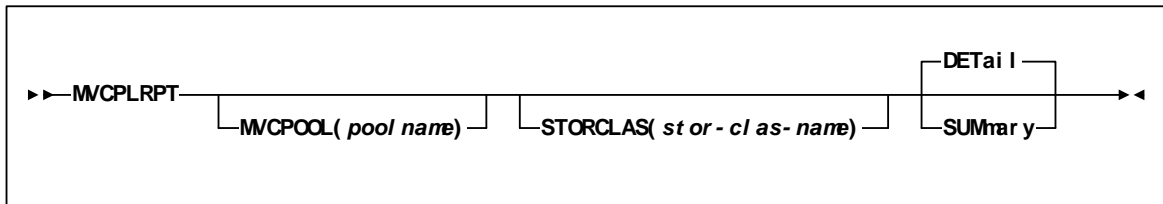

MVCRPt

Interfaces:

Utility only
 UUI: Yes

Subsystem Requirements:

Active HSC not required

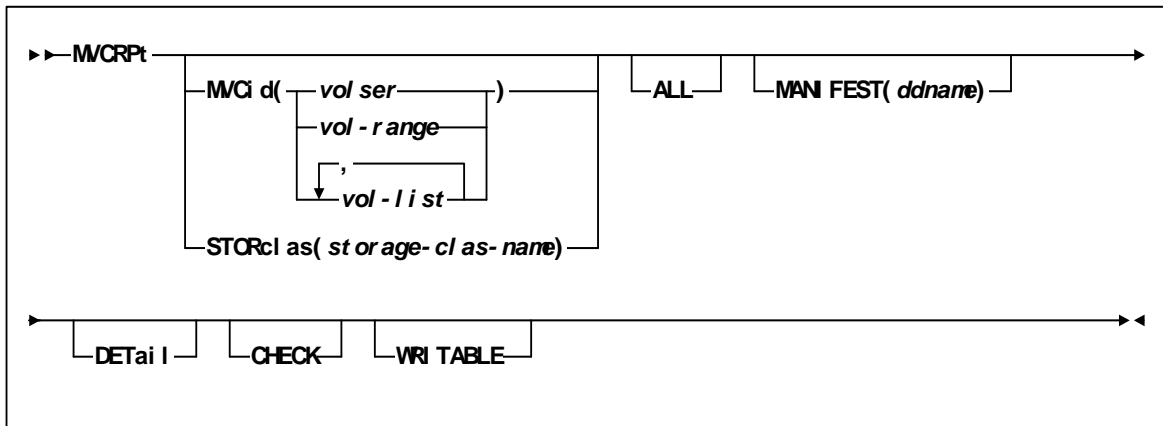

OFFload LOGFILE

Interfaces:

SLUADMIN utility only
 UUI: No

Subsystem Requirements:

Active HSC not required

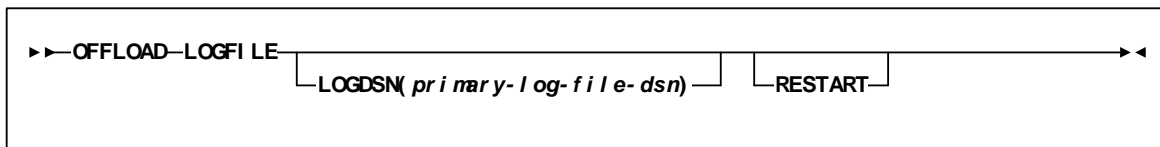

OPTION TITLE Control Statement

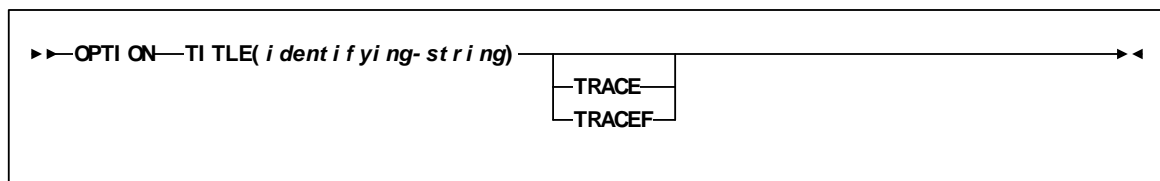

OPTion

Interfaces:

Console or PARMLIB only
 UUI: No

Subsystem Requirements:

Active HSC at BASE or FULL service level

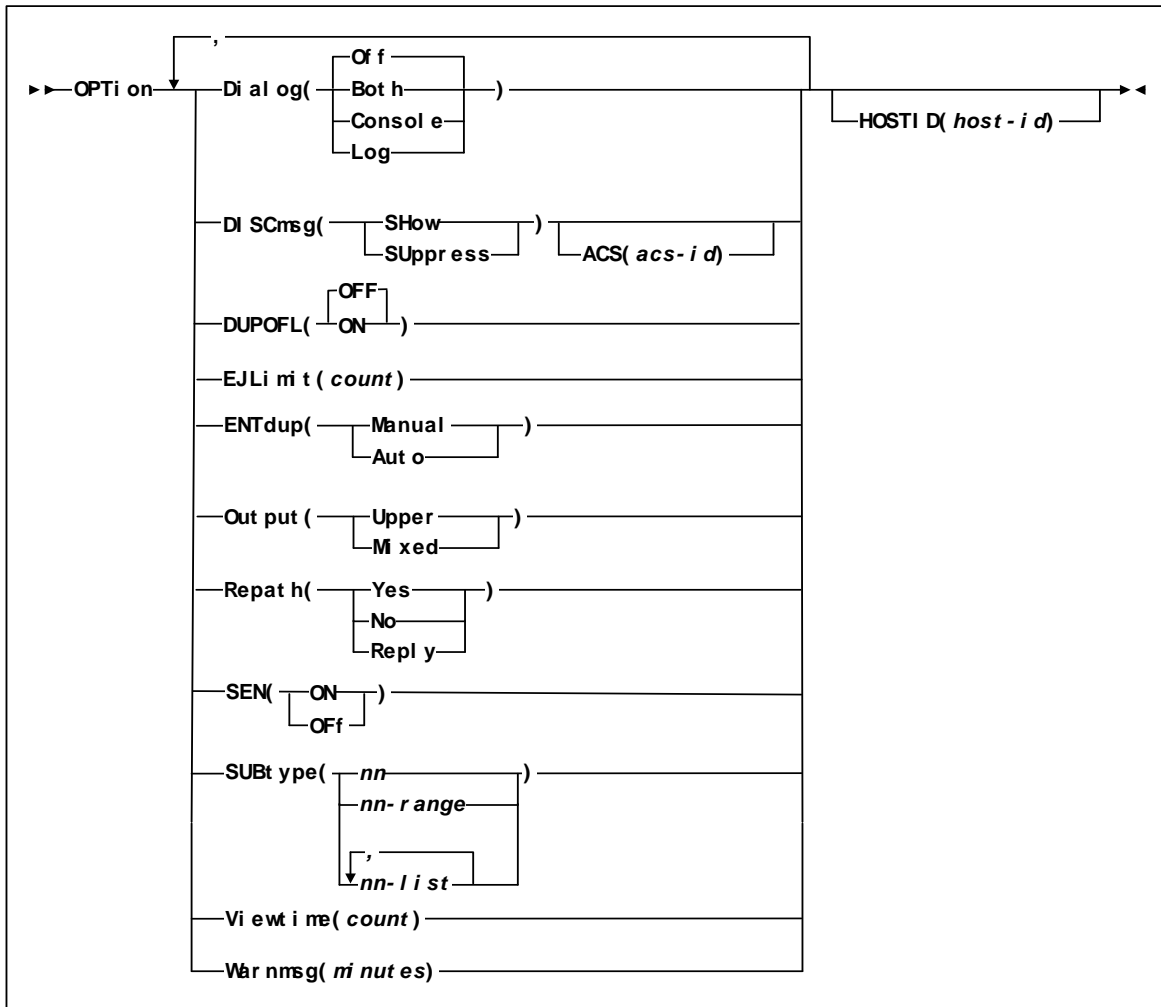

RECall

Interfaces:

Console or utility
 UUI: Yes

Subsystem Requirements:

Active HSC/VTCS

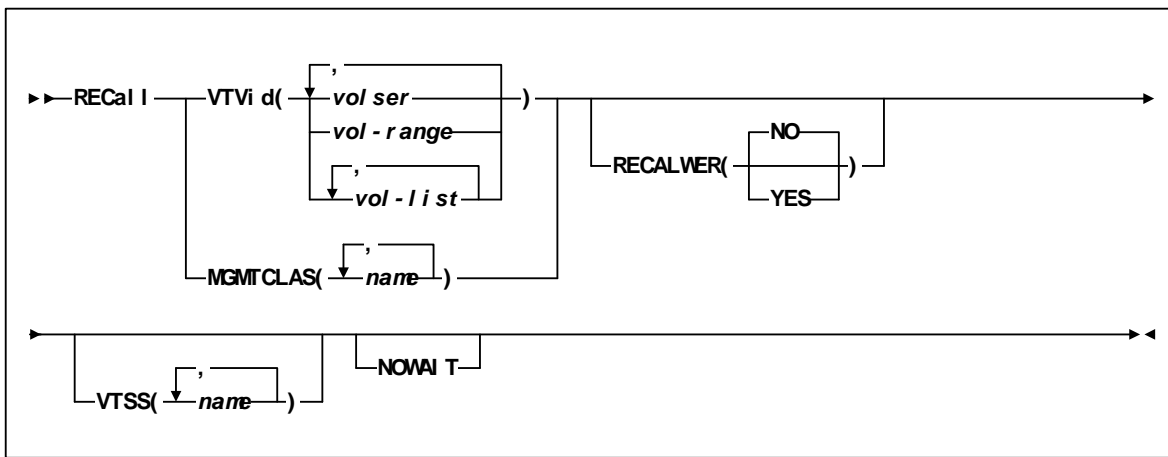

RECLaim

Interfaces:

Console or utility
 UUI: Yes

Subsystem Requirements:

Active HSC/VTCS

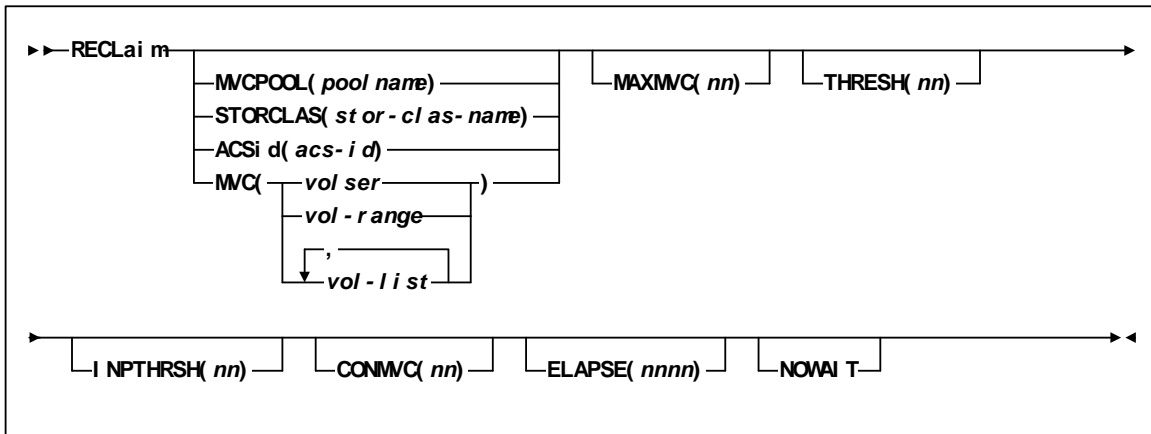

RECONcil

Interfaces:

Utility only
 UUI: Yes

Subsystem Requirements:

Active HSC/VTCS

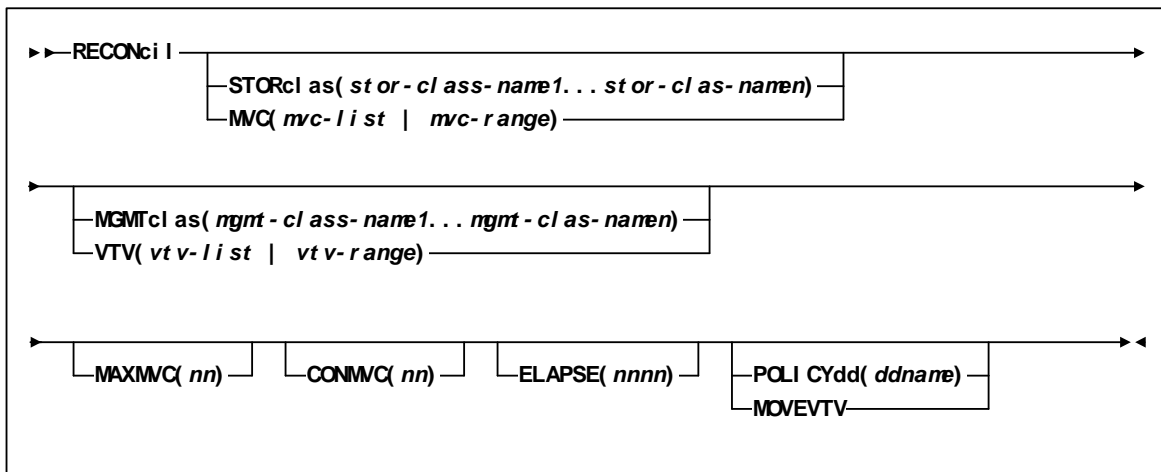

RECOVcr

Interfaces:

Console or PARMLIB
 UUI: No

Subsystem Requirements:

Active HSC at FULL service level

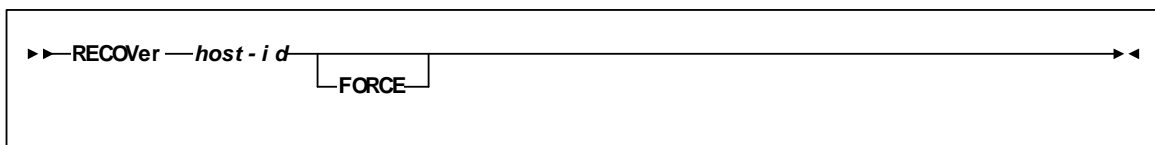

RELease

Interfaces:

Console or PARMLIB only
UII: No

Subsystem Requirements:

Active HSC at FULL service level

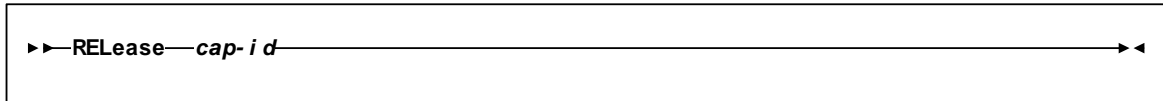

REPLaceall

Interfaces:

Console or utility
UII: Yes

Subsystem Requirements:

Active HSC at BASE or FULL service level

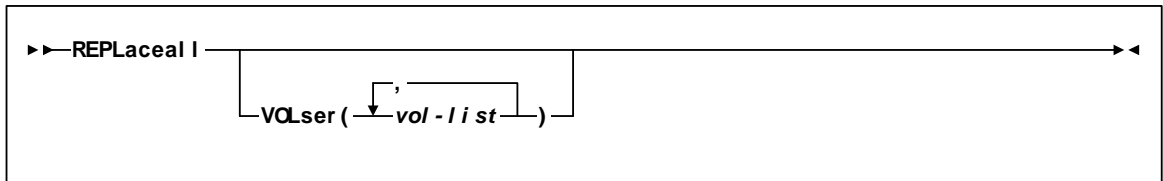

REStore

Interfaces:

SLUADMIN utility only
 UUI: No

Subsystem Requirements:

HSC must be down (inactive)

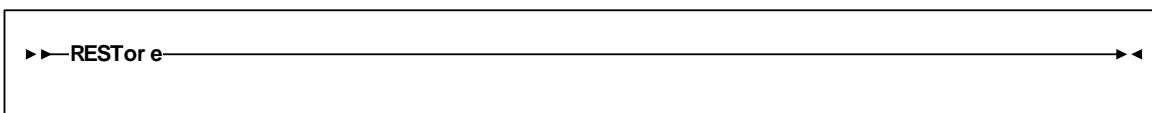

RTV Utility

Note – This VTCS utility is a standalone utility executed using the SWSRTV program.

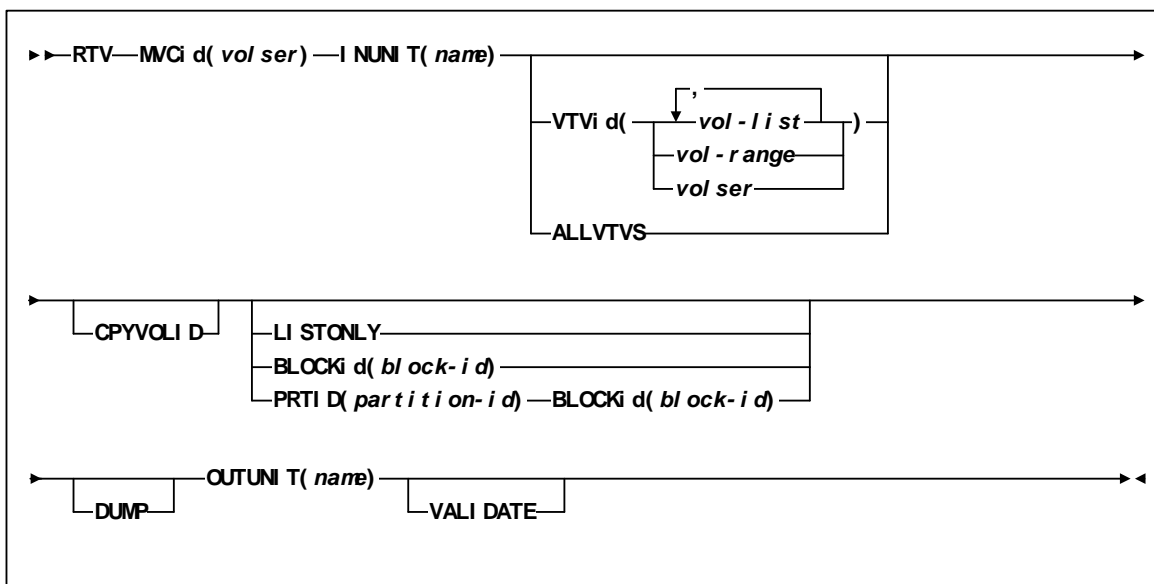

SCRAtch

Interfaces:

Console or utility
 UUI: Yes

Subsystem Requirements:

Active HSC at BASE or FULL service level



SCREdist

Interfaces:

SLUADMIN utility only
 UUI: No

Subsystem Requirements:

Active HSC at FULL service level

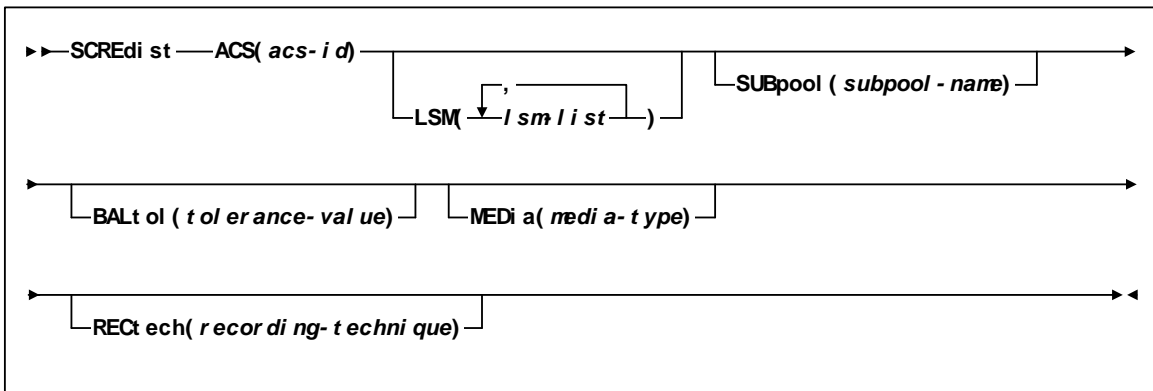

SCRPT

Interfaces:

SLUADMIN utility only

Subsystem Requirements:

Active HSC not required. SMC must be active and communicating with at least one VLE with the deduplication feature enabled to generate data in the report output. The report must be run from an authorized library.

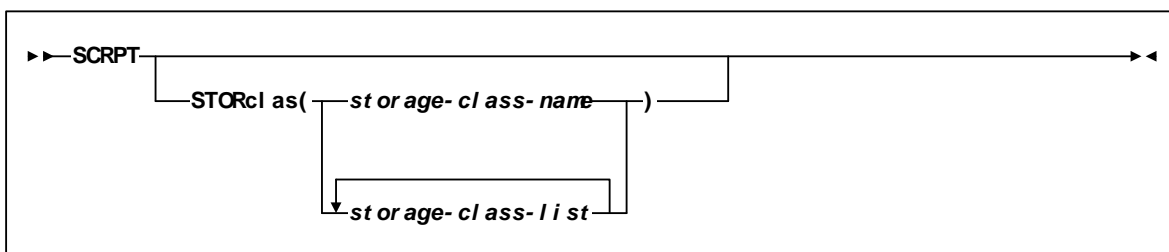

SENter

Interfaces:

Console or PARMLIB only
 UUI: No

Subsystem Requirements:

Active HSC at FULL service level

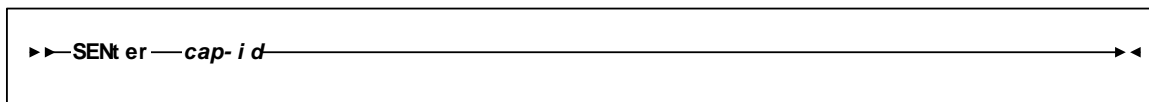

SET CLNPRFX

Note – HSC must be shut down on all systems before changing the cleaning prefix.

Interfaces:

SLUADMIN utility only
UII: No

Subsystem Requirements:

Active HSC not required

▶▶ SET—CLNPRFX(*prefix*) ◀◀

SET COMPREFX

Interfaces:

SLUADMIN utility only
UII: No

Subsystem Requirements:

Active HSC not required

▶▶ SET—COMPREFX(*cmdhex*) ◀◀

SET DRVHOST

Interfaces:

SLUADMIN utility only
 UUI: No

Subsystem Requirements:

Active HSC not required

```

▶▶ SET DRVHOST( OFF )
                |
                | host - i d
  
```

SET EJCTPAS

Interfaces:

SLUADMIN utility only
 UUI: No

Subsystem Requirements:

Active HSC not required

```

▶▶ SET EJCTPAS( newpswd )
                |
                | , OLDPASS( ol dpswd )
  
```

SET FREEZE

Interfaces:

SLUADMIN utility only
UII: No

Subsystem Requirements:

Active HSC not required

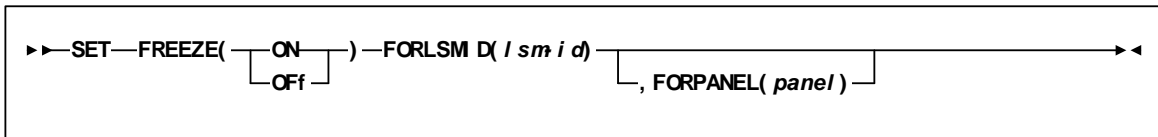

SET HOSTID

Interfaces:

SLUADMIN utility only
UII: No

Subsystem Requirements:

Active HSC not required

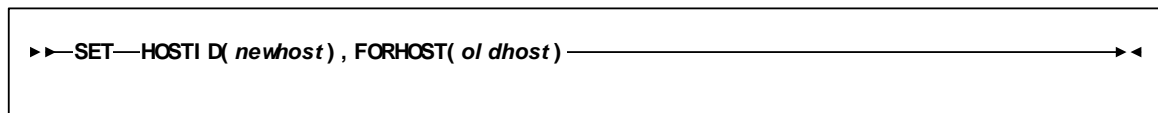

SET HSCLEVEL

Interfaces:

SLUADMIN utility only
 UUI: No

Subsystem Requirements:

Active HSC not required

```
▶▶ SET HSCLEVEL ( OFF ) , FORHOST( host - i d ) ◀◀
```

SET LOGFILE

Interfaces:

SLUADMIN utility only
 UUI: No

Subsystem Requirements:

Active HSC not required

```
▶▶ SET LOGFILE( primary-log-file-dsn ) ◀◀
      OFF      , secondary-log-file-dsn
      IMMED    , OFF
```

SET MAJNAME

Note – HSC must be shut down on all systems before changing the QNAME.

Interfaces:

SLUADMIN utility only
 UUI: No

Subsystem Requirements:

- Active HSC not required
- HSC must be shut down on all systems before changing the QNAME.

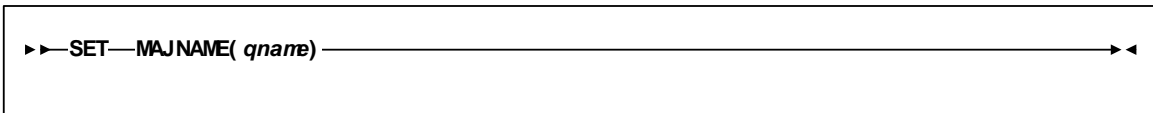

SET MIGOPT

Interfaces:

Console or utility
 UUI: Yes

Subsystem Requirements:

Active HSC/VTCS

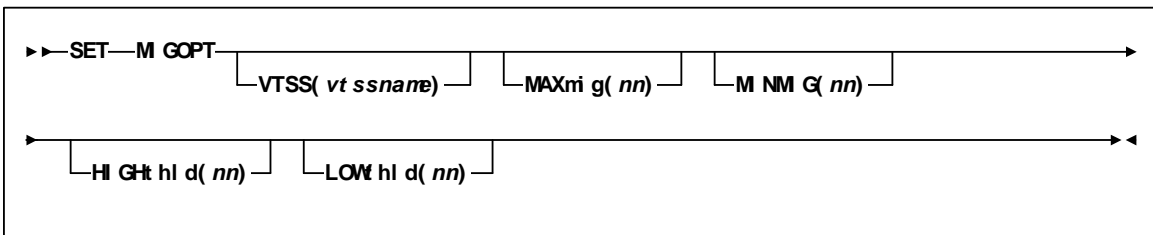

SET NEWHOST

Interfaces:

SLUADMIN utility only
 UUI: No

Subsystem Requirements:

Active HSC not required

```
▶▶ SET NEWHOST( newhost ) , LI KEHOST( model - host ) ◀◀
```

SET RMM

Interfaces:

Console or utility
 UUI: Yes

Subsystem Requirements:

Active HSC/VTCS

```
▶▶ SET RMM
      -ENabl e-
      -DI Sabl e-
```

SET SCRLABL

Interfaces:

SLUADMIN utility only
 UUI: No

Subsystem Requirements:

Active HSC not required

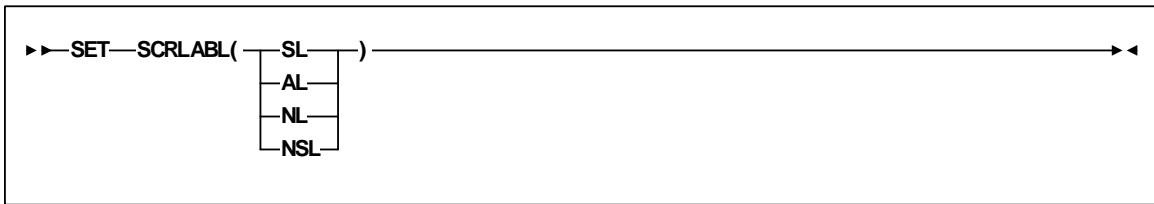

SET SLIDRIVS

Caution – For 9310 and 9740 libraries, Sun recommends you bring the HSC down on all hosts before specifying this parameter, and recycle the HSC after every SET SLIDRIVS operation.

Interfaces:

SLUADMIN utility only
 UUI: No

Subsystem Requirements:

Active HSC not required

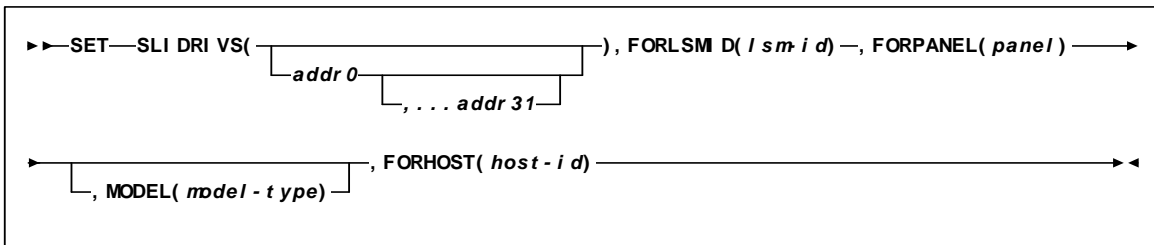

SET SLISTATN

Interfaces:

SLUADMIN utility only
 UUI: No

Subsystem Requirements:

Active HSC not required

▶▶ SET SLISTATN (st at 1, ..., st at 16), FORACS(*acs - i d*) , FORHOST(*host - i d*) ▶▶

SET SMF

Interfaces:

SLUADMIN utility only
 UUI: No

Subsystem Requirements:

Active HSC not required

▶▶ SET SMF(*l i b t y p e*) ▶▶

SET TAPEPlex

Interfaces:

SLUADMIN utility only
UII: No

Subsystem Requirements:

Active HSC not required

```
▶▶ SET TAPEPlex( tapeplex-name )◀◀
```

SET TECHNIQUE

Interfaces:

SLUADMIN utility only
UII: No

Subsystem Requirements:

Active HSC not required

```
▶▶ SET TECHNIQUE( NOE | SHADOW | STANDBY )◀◀
```

SET VAULT

Interfaces:

SLUADMIN utility only
 UUI: No

Subsystem Requirements:

Active HSC not required

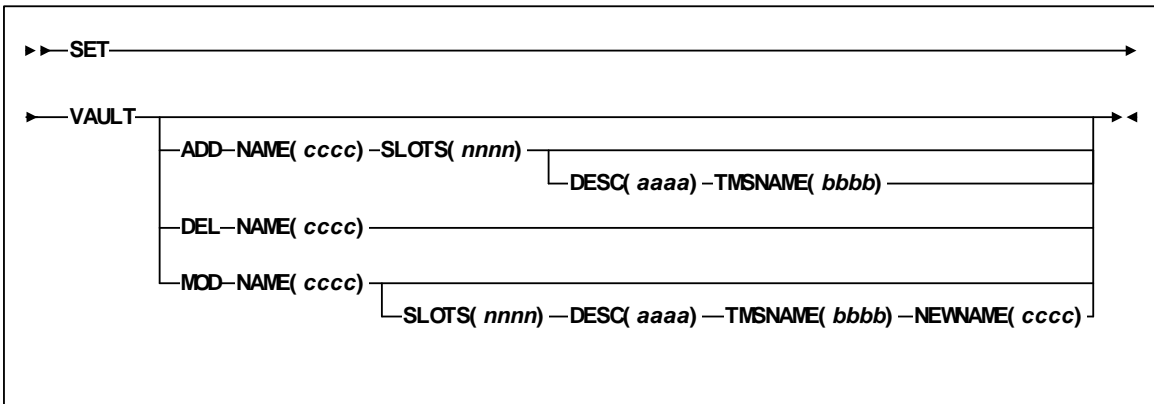

SET VAULTVOL

Interfaces:

SLUADMIN utility only
 UUI: No

Subsystem Requirements:

Active HSC not required

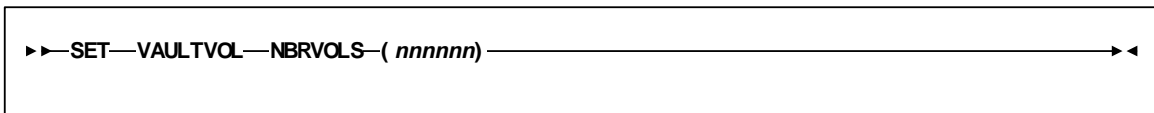

SET VOLPARM

Interfaces:

SLUADMIN utility only
UII: No

Subsystem Requirements:

Active HSC not required

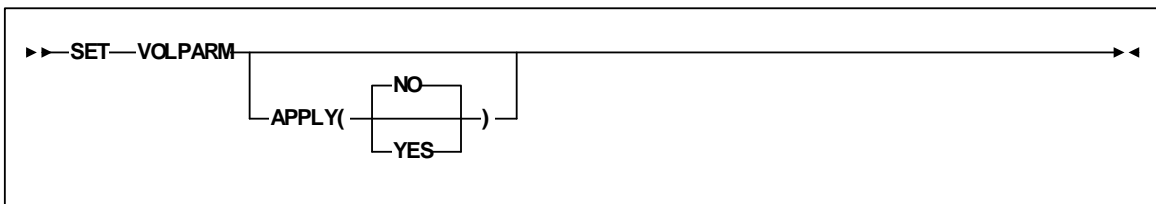

POOLPARM Control Statement

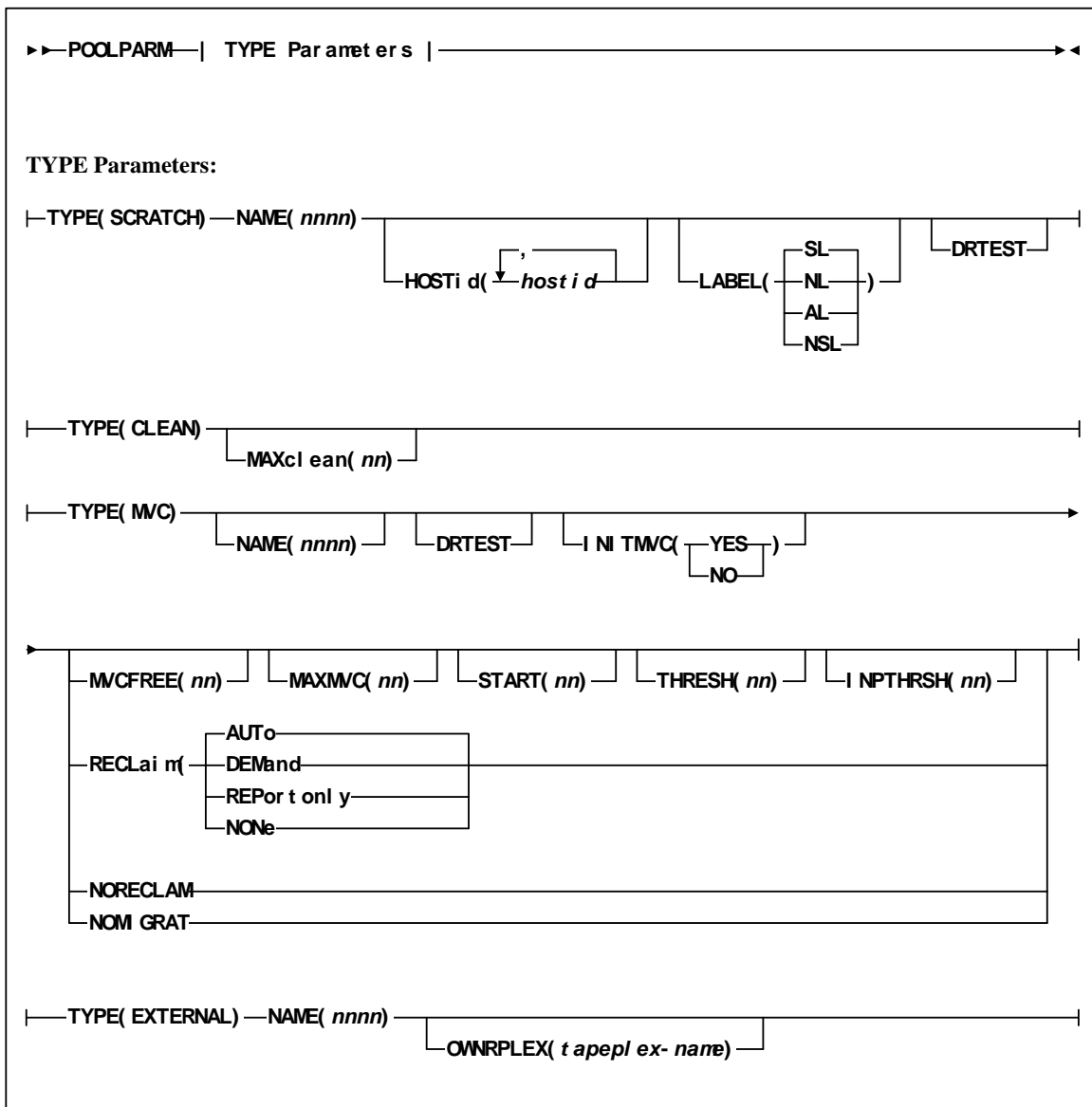

VOLPARM Control Statement

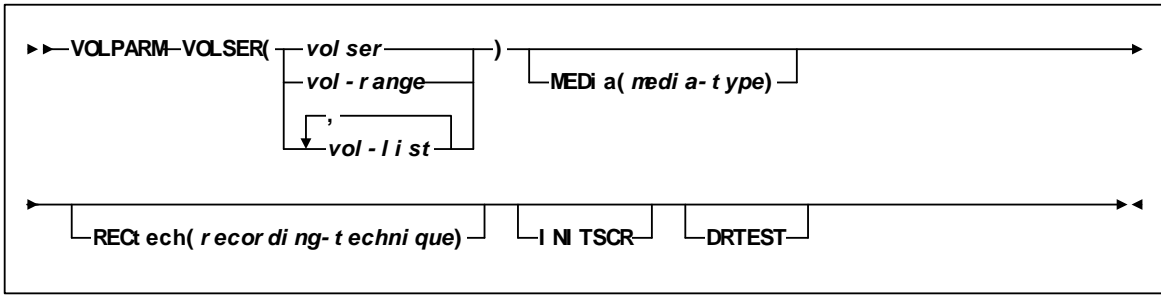

SRVlev

Interfaces:

Console or PARMLIB only
 UUI: No

Subsystem Requirements:

Active HSC at BASE or FULL service level

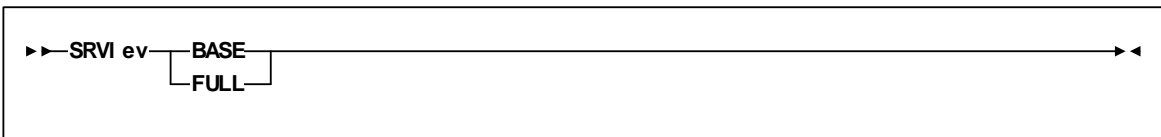

STOPMN

Interfaces:

Console or PARMLIB only
 UUI: No

Subsystem Requirements:

Active HSC at BASE or FULL service level

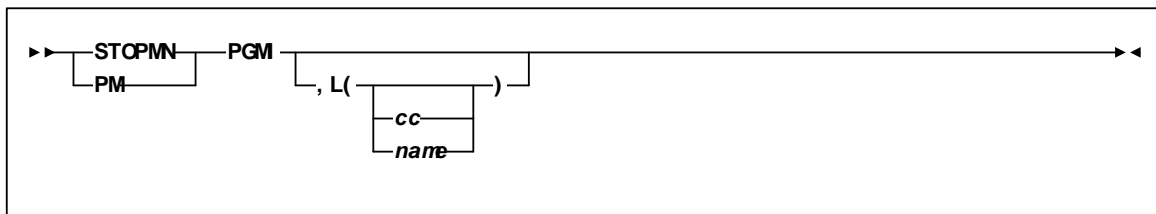

SWtch

Interfaces:

Console or PARMLIB only
 UUI: No

Subsystem Requirements:

Active HSC at FULL service level

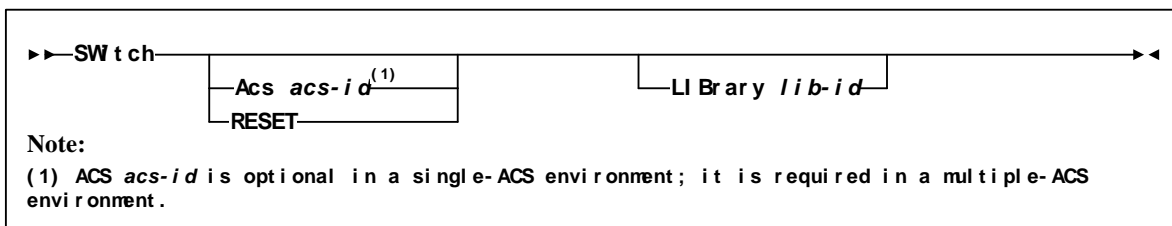

TRace

Interfaces:

Console or utility
UII: Yes

Subsystem Requirements:

Active HSC at BASE or FULL service level

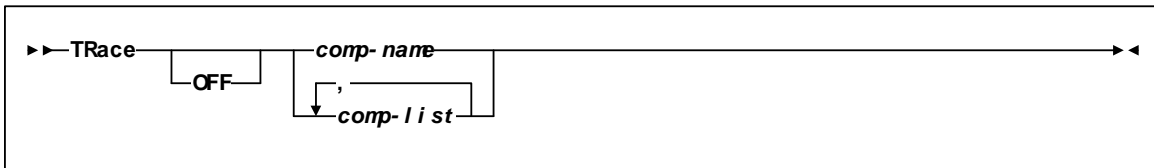

TRACELKP

Interfaces:

Console or PARMLIB only
UII: No

Subsystem Requirements:

Active HSC at BASE or FULL service level

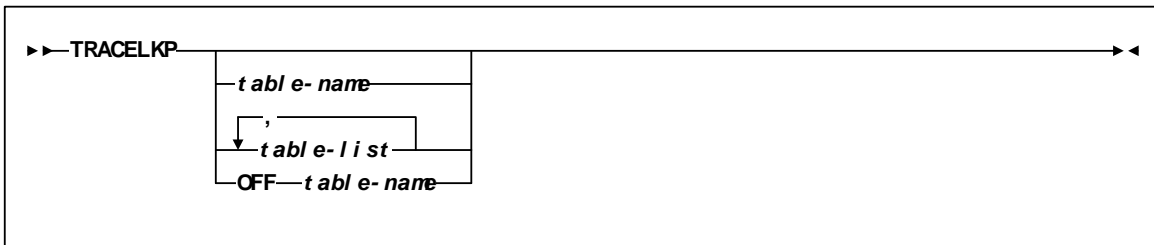

UEXIT

Interfaces:

Console or PARMLIB only
 UUI: No

Subsystem Requirements:

Active HSC at BASE or FULL service level

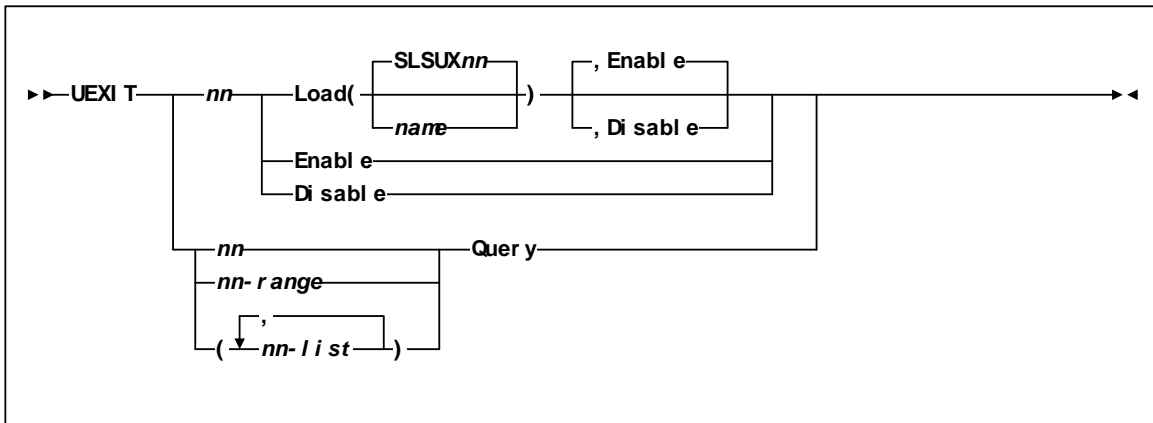

UNSCratch

Interfaces:

Console or utility
 UUI: Yes

Subsystem Requirements:

Active HSC at BASE or FULL service level

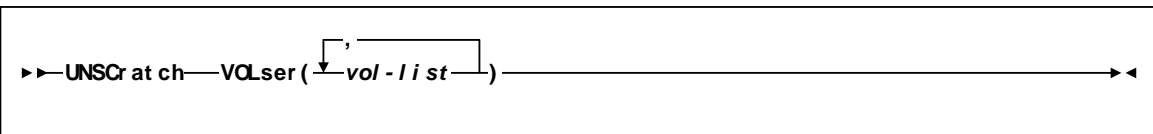

UNSElect

Interfaces:

SLUADMIN utility only
UII: No

Subsystem Requirements:

Active HSC not required

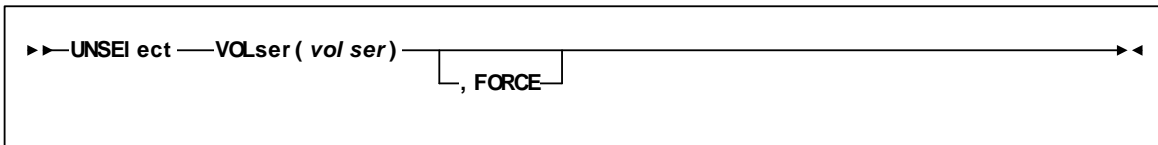

Vary

Interfaces:

- Console or PARMLIB (Vary ACS)
- Console or utility, UUI All (Vary CLINK, RTD, or VTSS)

UUI: Yes

Subsystem Requirements:

- Active HSC at FULL service level (Vary ACS)
- Active HSC/VTCS (Vary CLINK, RTD, or VTSS)

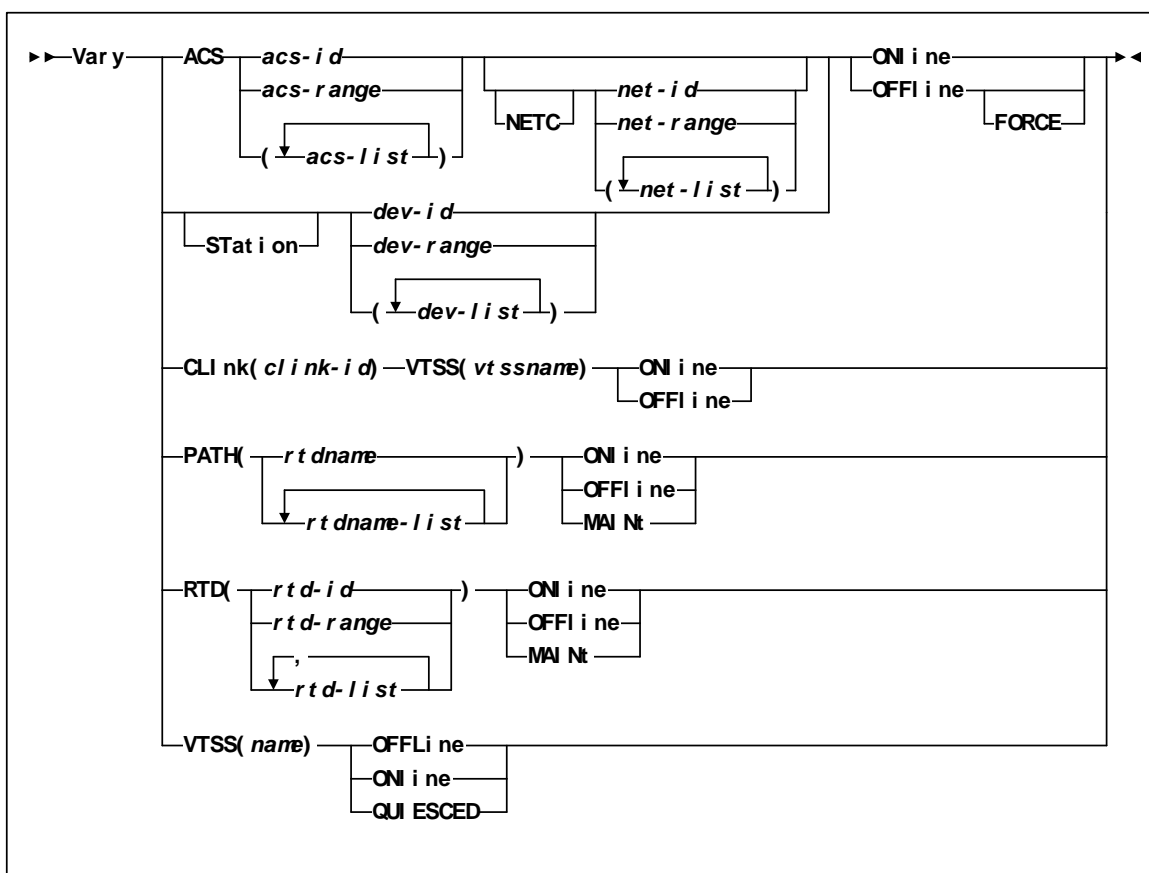

View

Interfaces:

Console or PARMLIB only
 UUI: No

Subsystem Requirements:

Active HSC at FULL service level

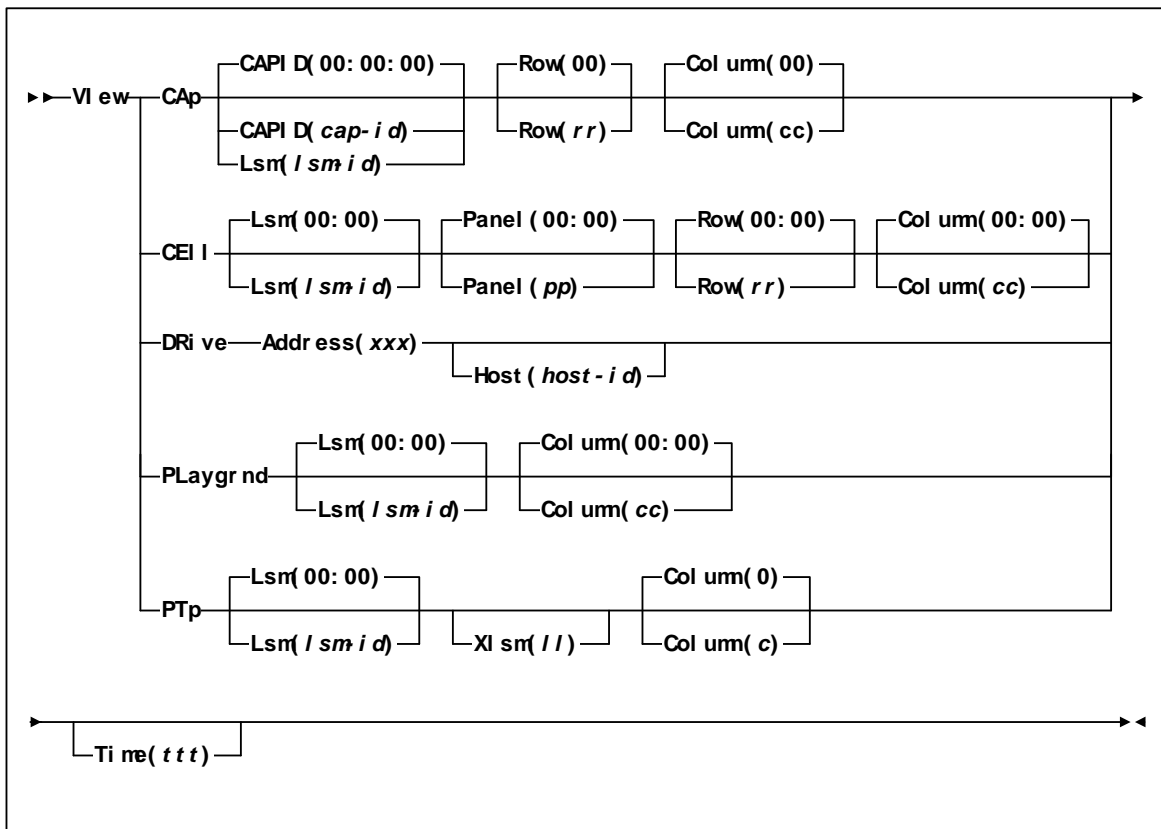

VOLPCONV

Interfaces:

SLUADMIN utility only
UII: No

Subsystem Requirements:

Active HSC not required

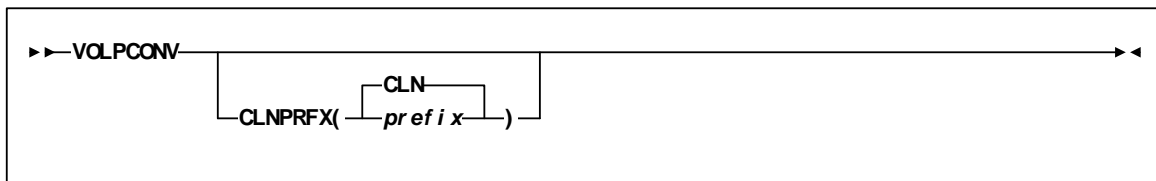

VOLRpt

Interfaces:

Utility only
 UUI: Yes

Subsystem Requirements:

Active HSC not required

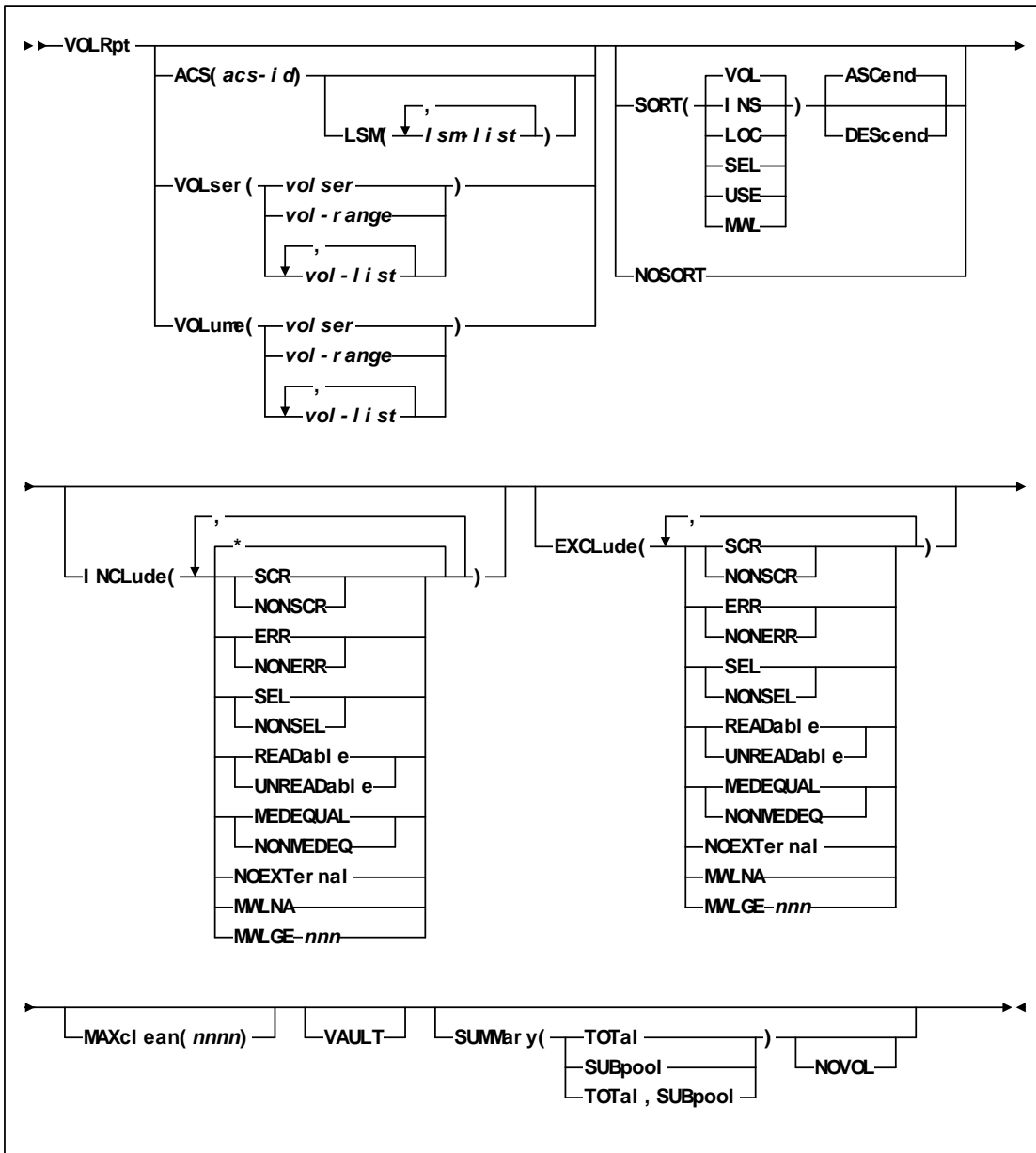

VTVMaint

Interfaces:

Utility only
 UUI: Yes

Subsystem Requirements:

Active HSC at FULL service level

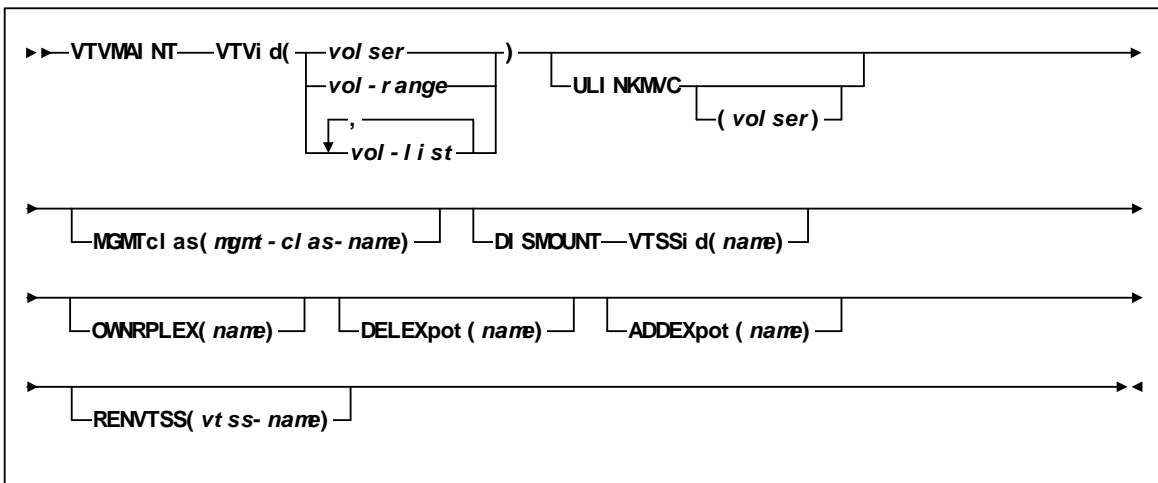

VTVRPt BASIC

Interfaces:

Utility only
 UUI: Yes

Subsystem Requirements:

Active HSC not required

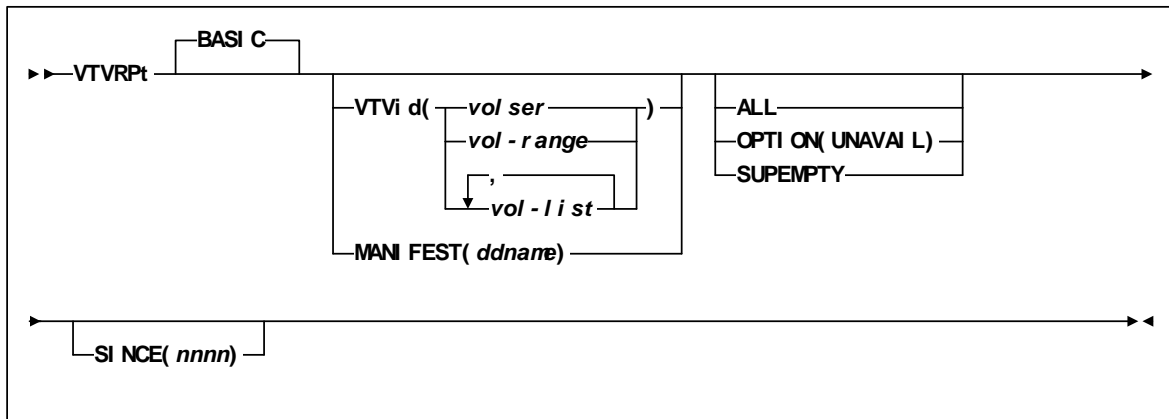

VTVRP_t COPIES

Interfaces:

Utility only
 UUI: Yes

Subsystem Requirements:

Active HSC not required

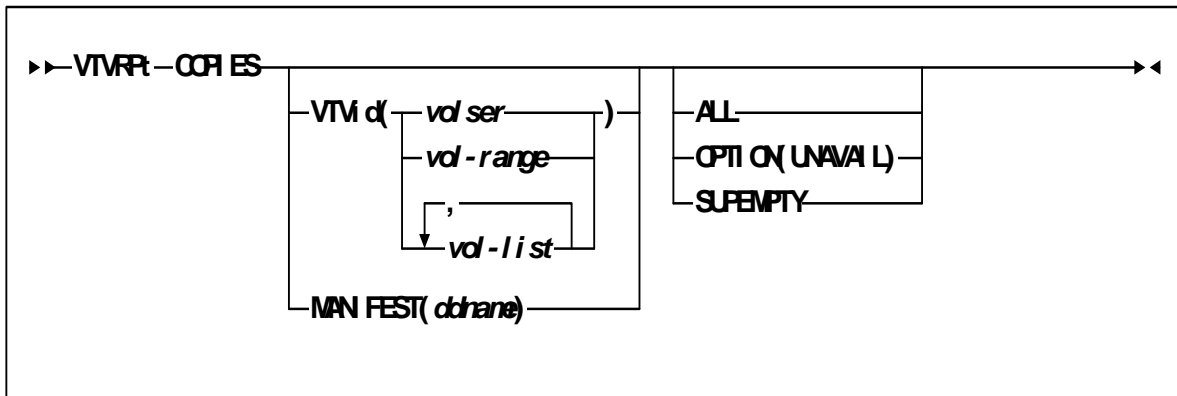

VVAUDIT

Interfaces:

Utility only
 UUI: Yes

Subsystem Requirements:

Active HSC at BASE or FULL service level

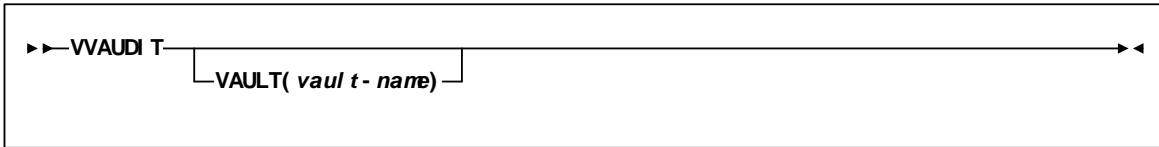

Warn

Interfaces:

Console or PARMLIB only
 UUI: No

Subsystem Requirements:

Active HSC at BASE or FULL service level

