

StorageTek Enterprise Library Software

LCM User's Guide

Version 7.0

ORACLE

Revision 02
Part Number: E37172-02

Submit comments about this document to STP_FEEDBACK_US@ORACLE.COM.

LCM User's Guide

E37172-02

Copyright © 2012 Oracle and/or its affiliates. All rights reserved.

This software and related documentation are provided under a license agreement containing restrictions on use and disclosure and are protected by intellectual property laws. Except as expressly permitted in your license agreement or allowed by law, you may not use, copy, reproduce, translate, broadcast, modify, license, transmit, distribute, exhibit, perform, publish, or display any part, in any form, or by any means. Reverse engineering, disassembly, or decompilation of this software, unless required by law for interoperability, is prohibited.

The information contained herein is subject to change without notice and is not warranted to be error-free. If you find any errors, please report them to us in writing.

If this is software or related software documentation that is delivered to the U.S. Government or anyone licensing it on behalf of the U.S. Government, the following notice is applicable:

U.S. GOVERNMENT RIGHTS Programs, software, databases, and related documentation and technical data delivered to U.S. Government customers are "commercial computer software" or "commercial technical data" pursuant to the applicable Federal Acquisition Regulation and agency-specific supplemental regulations. As such, the use, duplication, disclosure, modification, and adaptation shall be subject to the restrictions and license terms set forth in the applicable Government contract, and, to the extent applicable by the terms of the Government contract, the additional rights set forth in FAR 52.227-19, Commercial Computer Software License (December 2007). Oracle USA, Inc., 500 Oracle Parkway, Redwood City, CA 94065.

This software or hardware is developed for general use in a variety of information management applications. It is not developed or intended for use in any inherently dangerous applications, including applications which may create a risk of personal injury. If you use this software or hardware in dangerous applications, then you shall be responsible to take all appropriate fail-safe, backup, redundancy, and other measures to ensure the safe use. Oracle Corporation and its affiliates disclaim any liability for any damages caused by use of this software or hardware in dangerous applications.

Oracle is a registered trademark of Oracle Corporation and/or its affiliates. Oracle and Java are registered trademarks of Oracle and/or its affiliates. Other names may be trademarks of their respective owners.

AMD, Opteron, the AMD logo, and the AMD Opteron logo are trademarks or registered trademarks of Advanced Micro Devices. Intel and Intel Xeon are trademarks or registered trademarks of Intel Corporation. All SPARC trademarks are used under license and are trademarks or registered trademarks of SPARC International, Inc. UNIX is a registered trademark licensed through X/Open Company, Ltd.

This software or hardware and documentation may provide access to or information on content, products, and services from third parties. Oracle Corporation and its affiliates are not responsible for and expressly disclaim all warranties of any kind with respect to third-party content, products, and services. Oracle Corporation and its affiliates will not be responsible for any loss, costs, or damages incurred due to your access to or use of third-party content, products, or services.

Preface

Oracle's StorageTek™ Enterprise Library Software (ELS) is a solution consisting of the following base software:

- StorageTek™ Storage Management Component (SMC)
(includes the product formerly known as StorageTek HTTP Server)
- StorageTek™ Host Software Component (HSC)
- StorageTek™ Virtual Tape Control Software (VTCS)
- StorageTek™ Concurrent Disaster Recovery Test (CDRT)

Additionally, the following software is provided with the ELS package:

- ELS Supportive Software:
 - StorageTek™ Library Content Manager (LCM) (formerly ExLM)
(includes the product formerly known as Offsite Vault Feature)
 - StorageTek™ Enterprise Library Management Station Media Audit Tracker (ELMS MAT)
- Other Mainframe Software:
 - StorageTek™ Client System Component for MVS Environments (MVS/CSC)
 - StorageTek™ LibraryStation
 - Refer to the publication *Introducing ELS* for an overview of the ELS solution.

LCM 7.2 is only executable with the enablement components of ELS 7.2 (SMC, HSC and VTCS 7.2), however it will be able to execute any existing ExLM 6.0 or 6.2 parameter file used in conjunction with NCS/VTCS 6.0, 6.1 or 6.2 releases.

Audience

This guide is for StorageTek or customer personnel who are responsible for configuring and administering ExLM.

Prerequisites

To perform the tasks described in this guide, you should already understand the following:

- MVS or OS/390 operating system
- ELS
- Your tape management system
- Operational requirements of your site for scratch volumes, free cells, and remote vaulting

Organization of This Publication

TABLE P-1 describes the contents of this publication.

TABLE P-1 Organization of this Publication

Section	Contents
“LCM Overview” on page 1	LCM overview
“Using LCM to Manage Nearline and VTCS Resources” on page 7	General LCM usage guidelines
“Using LCM with Your TMS” on page 35	LCM usage for supported TMSs
“LCM Management Control Statements” on page 85	Reference information for LCM Management control statements
“LCM Action Control Statements” on page 181	Reference information for LCM ACTION control statements
“LCM Reports Control Statements” on page 275	Reference information for LCM REPORT control statements
“LCM Operator Commands” on page 379	Reference information for LCM operator commands
“LCM SAMPLIB Members” on page 389	Reference information for LCM SAMPLIB members
“A Sample LCM Workflow” on page 391	Sample workflow for LCM usage
“ELS Alphabetic Volsers” on page 395	Reference information for ELS alphabetic volsers
“Data Areas” on page 401	Reference information for LCM data areas
“Elements Tags for Dynamically Added Fields” on page 411	Reference information for element tags that can be used when defining dynamic volume fields within the TMS Interface Definition Response Document
“Using the Performance Zone” on page 415	Using the Performance Zone for SL8500 libraries.

This book also has a glossary and index.

Contents

Preface	iii
Audience	iii
Prerequisites	iv
Organization of This Publication	v
1. LCM Overview	1
LCM Management Services for Nearline Systems	2
LCM Management Services for VSM Systems	3
How Does LCM Work?	4
LCM Processing	6
2. Using LCM to Manage Nearline and VTCS Resources	7
LCM Usage Considerations	8
LCM Parameter Files	9
LCM Management Control Statements	10
LCM Reports	12
LCM Standard Reports	12
LCM Optional Reports	14
LCM Custom Reports	14
REPORT Statement Guidelines	14
REPORT Statement Templates	15
LCM ACTION Control Statements	16
Parameter File Syntax Requirements	17
Subparameter Data Types	17
LCM Fields	22

Creating an LCM Batch Job	23
JCL EXEC Statement	24
Parameters	24
Required and Optional JCL DD Statements	25
Using LCM to Manage Nearline Resources	28
Using LCM to Manage VSM Resources	30
General Guidelines	30
Using LCM to do VTV Consolidations	31
Using LCM to do Migrates and Recalls	32
Using LCM to do Exports	33
3. Using LCM with Your TMS	35
General Guidelines for Defining TMSs	36
▼ Setting Up the LCM Interface to Any TMS	37
Using LCM with CA-1	38
▼ Managing a Single Scratch Volume Subpool	39
▼ Managing Multiple Scratch Volume Subpools	40
▼ Defining VMS Vault Names to LCM with LOCATION Statements	41
How LCM Manages Out-of-Area Codes without Corresponding LOCATION Statements	43
▼ Using LCM to Manage Vault Rotation	44
▼ Using LCM to Manage Data Sets	44
▼ Using LCM to Manage Expired Volumes	45
▼ Using LCM to Unconditionally Eject Volumes Deleted from the CA-1 TMC	45
How LCM Processes Specific OPTIONS Statement Parameters For CA-1	46
CYCLESOON	46
EJBAD	46
PICKSCR	47
Using LCM with DFSMSrmm	48
▼ Using the DFSMSrmm API to Obtain Volume Information	48
▼ Managing a Single Scratch Volume Subpool	50
▼ Managing Multiple Scratch Volume Subpools	50
Using LCM with the DFSMSRMM Vital Record Specifications	52

▼	Defining VRS Store Location Names to LCM with LOCATION Statements	52
	How LCM Manages Location Codes without Corresponding LOCATION Statements	54
▼	Using LCM to Manage Volume Movement	55
▼	Using LCM to Manage Expired Volumes	56
	How LCM Processes Specific OPTIONS Statement Parameters For DFSMSrmm	56
	CYCLESOON	56
	EJBAD	56
	PICKSCR	56
	Using LCM with CA-TLMS	57
▼	Managing a Single Scratch Volume Subpool	59
▼	Managing Multiple Scratch Volume Subpools	59
▼	Using LCM with the CA-TLMS Tape Retention System	60
▼	Defining TRS Location IDs to LCM with LOCATION Statements	60
	How LCM Manages Location IDs without Corresponding LOCATION Statements	61
▼	Using LCM to Manage Volume Movement	61
▼	Using LCM to Manage Data Sets	62
▼	Using LCM to Manage Externally Managed Volumes	63
	How LCM Processes Specific OPTIONS Statement Parameters For CA-TLMS	64
	CYCLESOON	64
	64	
	EJBAD	65
	PICKSCR	65
	EXPIRECHECK	65
	Using LCM with Control-T	66
	Required Software Maintenance Levels for Control-T Support	66
	JCL Changes for LCM Jobs	66
	Using LCM with a Custom TMS Interface Module	67
▼	Creating and Implementing a TMS CUSTOM Interface Module	67
▼	Creating an LCMSTMCI Subroutine	67
▼	Creating an LCMITMSG Subroutine	68

TMS CUSTOM Interface Module Entry Conditions	69
TMS CUSTOM Interface Module Linkage Conventions	69
TMS CUSTOM Interface Module Return Conditions	70
TMS CUSTOM Interface Module Parameters	70
▼ Testing a TMS CUSTOM Interface Module	71
TMSs Supported through the Custom Interface	72
Using LCM with Open Systems Clients	73
TMS Interface Definition Request Document	74
Element Tag Descriptions	75
TMS Interface Definition Response Document	76
Element Tag Descriptions	77
TMS Tape Information Request Document	78
Element Tag Descriptions	79
TMS Tape Information Response Document	80
Element Tag Descriptions	81
Information regarding tape metadata within a volume element tag:	82
Dynamically Added Volume Fields	83
TMS OPEN Document Type Definitions (DTDs)	84
TMS Interface Definition Response DTD	84
TMS Tape Information Response DTD	84
4. LCM Management Control Statements	85
DATASET	86
Syntax	86
Parameters	87
Usage	89
LOCATION	91
Syntax	91
Parameters	92
MANAGE PHYSICAL	96
Syntax	97
Usage	103
Restrictions	104
MANAGE VIRTUAL	105

Syntax	105
Parameters	105
Usage	105
METHOD	106
Syntax	107
Parameters	108
Usage	112
OPTIONS	114
Syntax	115
Parameters	116
Usage	125
Running LCM without a TMS	127
The LCM Eject File	128
Examples	130
PULLLIST	131
Syntax	131
Parameters	131
Usage	133
SET METHOD	134
Syntax	134
Parameters	135
Usage	138
Examples	139
SET METHOD Statement WHEN Fields	139
SUBPOOL	140
Syntax	140
Parameters	141
Usage	145
Examples	146
Volsers Only	146
Volsers and Media Type	146
Ignore Subpool	146
Assign Method NEVEREJECT to Subpool	147

Unconditionally Assign Method NEVEREJECT to Subpool	147
TMS CA1	148
Syntax	148
Parameters	149
Usage	150
TMS COMMON	151
Syntax	151
Parameters	152
Usage	154
TMS CTT	155
Syntax	155
Parameters	156
Usage	157
TMS CUSTOM	158
Syntax	158
Parameters	159
Usage	161
TMS OPEN	162
Syntax	162
Parameters	163
Usage	165
TMS RMM	166
Syntax	166
Parameters	167
Usage	170
TMS TLMS	171
Syntax	171
Parameters	172
Usage	174
UNMANAGED	175
Syntax	175
Parameters	175
Usage	176

VAULT 177

Syntax 177

Parameters 177

Usage 180

5. LCM Action Control Statements 181

ACTION CONSOLIDATE 182

Syntax 182

Parameters 183

Usage 187

ACTION DRAIN 188

Syntax 188

Parameters 189

Usage 194

Example 194

ACTION EJECT 195

Syntax 195

Parameters 196

Usage 201

ACTION EXPORT 203

Syntax 203

Parameters 204

Usage 210

ACTION MIGRATE 211

Syntax 211

Parameters 212

Usage 217

Example 217

ACTION MOVE 218

Syntax 218

Parameters 218

Usage 224

Examples 224

ACTION RECALL 226

Syntax	226
Parameters	226
Usage	232
Example	232
ACTION RECLAIM	233
Syntax	233
Parameters	234
Usage	239
Example	239
ACTION RETURN	240
ACTION SCRATCH	241
Syntax	241
Parameters	242
Usage	246
Example	246
ACTION UNSCRATCH	247
Syntax	247
Parameters	248
Usage	252
Example	252
ACTION VAULT ASSIGN	253
Syntax	253
Parameters	254
Usage	259
ACTION VAULT RELEASE	260
Syntax	260
Parameters	261
Usage	266
ACTION VAULT RETURN	267
Syntax	267
Parameters	268
Usage	273

6. LCM Reports Control Statements 275

REPORT CELLCNT	277
Syntax	277
Parameters	278
Usage	279
Cell Count Report	279
REPORT CONSOLIDATE	281
Syntax	281
Parameters	281
Usage	282
Consolidation Report	283
REPORT EJECT	284
Syntax	284
Parameters	284
Usage	285
Eject Report	286
REPORT ENTER	288
Syntax	288
Parameters	288
Usage	289
Enter Report	290
REPORT EXPORT	291
Syntax	291
Parameters	291
Usage	292
Export Report	293
REPORT MIGRATE	295
Syntax	295
Parameters	295
Usage	296
Migration Report	297
REPORT NONSRCNT	298
Syntax	298
Parameters	298

Usage	300
Nonscratch Counts Reports	300
REPORT OPERATOR	305
Syntax	305
Parameters	305
Usage	306
Operator Report	306
REPORT RECALL	308
Syntax	308
Parameters	308
Usage	309
Recall Report	310
REPORT SCRCNT	311
Syntax	311
Parameters	311
Usage	313
Scratch Counts Report	314
REPORT SUMMARY	316
Syntax	316
Parameters	316
Usage	317
Summary Report	317
REPORT DATASET	321
Syntax	321
Parameters	321
Usage	323
Data Set Report	323
REPORT MULTIPLE	325
Syntax	325
Parameters	326
REPORT PHYSICAL	331
Syntax	331
Parameters	332

Usage	338
REPORT VAULT	339
Syntax	339
Parameters	340
Usage	344
Default Vault Report	345
Summary Vault Report	345
MVC Vault Report	345
Detail Vault Report	346
REPORT VIRTUAL	347
Syntax	347
Parameters	347
Usage	352
REPORT LSM	354
Syntax - REPORT LSM	354
REPORT MVC_VTV	356
Syntax - REPORT MVC_VTV	356
REPORT VOLUME	358
Syntax - REPORT VOLUME	358
Custom Report Parameters	360
Custom Report Fields	371
Usage	373
Examples	374
Custom Volume Reports	374
Custom LSM Reports	375
7. LCM Operator Commands	379
Using MVS Commands	380
Using the MVS MODIFY Command to Monitor and Control LCM Batch Jobs	380
Using the MVS STOP Command to Stop LCM	380
Using the MVS MODIFY Command to Monitor and Control LCM Agent	380
DISPLAY	381
Syntax	381

Parameters	381
Usage	382
Examples	382
Output	382
PAUSE	383
Syntax	383
Parameters	383
Usage	384
Examples	384
Output	384
REDIRECT	385
Syntax	385
Parameters	385
Usage	385
Examples	385
Output	385
RESUME	386
Syntax	386
Parameters	386
Usage	387
Examples	387
A. LCM SAMPLIB Members	389
B. A Sample LCM Workflow	391
Scratch Synchronization Parameter File	392
Basic “Manage” Parameter File	392
Manage File to Adjust Resources	393
Parameter File for Vaulting Run	394
C. ELS Alphabetic Volsers	395
Alphabetic Volser Examples	397
D. Data Areas	401
TMCI Record	402

Guidelines for Producing TMCI Records	403
TMCI Record Layout	404
TMCI Record Date Formats	406
TMCI Record Time Formats	407
TMCI Record Boolean Formats	407
TMCI_EXPIREDATE Special Formats	408
METHODFILE Record	409
E. Elements Tags for Dynamically Added Fields	411
Field Descriptions	413
F. Using the Performance Zone	415
SL8500 Performance Zone	416
SL3000 Performance Zone	417

LCM Overview

Library Content Manager (LCM) is MVS host software that manages Nearline and VSM resources. LCM also includes LCM Explorer, a graphical user interface that you can use to configure LCM by creating configuration files instead of parameter files.

Note – LCM 7.2 is only executable with the enablement components of ELS 7.2 (SMC, HSC and VTCS 7.2), however it will be able to execute any existing ExLM 6.0 or 6.2 parameter file used in conjunction with NCS/VTCS 6.0, 6.1 or 6.2 releases.

LCM Management Services for Nearline Systems

LCM can provide the following management services for Nearline systems:

- Maintain sufficient levels of scratch volumes by:
 - Distributing scratch volumes across LSMs within an ACS.
 - Synchronizing a volume's HSC scratch status with the tape management system (TMS) scratch status.

LCM can also mark a volume as "unscratch" to HSC even if it is defined as scratch to the TMC. This feature lets you maintain a reserve of scratch volumes that HSC does not select for scratch mounts until you use LCM to mark them as scratch to HSC.

- Ejecting scratch volumes that have been marked defective by the TMS.
- Requesting additional scratch volumes on the Enter Report.
- Maintain sufficient levels of free cells by:
 - Ejecting excess scratch volumes and less active data volumes.
 - Distributing free cells across LSMs within an ACS.
- Maintain sufficient levels of cleaning cartridges.
- If desired, manage LSM contents (scratch volumes, nonscratch volumes, and free cells) by individual LSMs or by groups (which can be divided into subgroups) of LSMs.
- LCM can also manage LSMs as a hierarchy. For example, LCM can:
 - "Promote" the most active data volumes by moving them up to LSMs higher in the hierarchy.
 - "Demote" less active data volumes by moving them down to LSMs lower in the hierarchy, which creates free cells in LSMs higher in the hierarchy.
 - Maintain scratch levels in LSMs higher in the hierarchy by "promoting" scratch volumes to these LSMs.
- Concentrate operator tasks (entering and removing volumes) around specific time periods (such as at the beginning of each shift or during periods of low activity). For example, a job scheduler can generate a "pull list" of volumes required for an upcoming production run. LCM adds any pull list volumes not in the ACS to the Enter Report, and frees cells needed for these volumes.
- Support multi-volume data sets. If all volumes in a multi-volume data set have the same LCM management method, LCM will manage all volumes together. If these volumes have different management methods, LCM will manage them individually.
- Provide standard and customized LSM and volume reports. LCM also maintains log files that log LCM actions.
- Provide the ability to do ad hoc volume ejects (ACTION EJECT), moves (ACTION MOVE), scratches (ACTION SCRATCH), and unscratches (ACTION UNSCRATCH).

LCM Management Services for VSM Systems

LCM provides the following management services for VSM systems:

- Manages subpools that contain VTVs (defined as MEDIA(VIRTUAL)).
- Synchronizes a VTV's HSC scratch status with the TMS scratch status via the OPTIONS statement SYNCVTV parameter.
- Manages MVCs.
- Displays VTV and MVC information on consolidation, migrate, recall, scratch counts, nonscratch counts, summary reports, and custom volume, MVC, and VTV reports.
- Consolidates, migrates, recalls, scratches, and unscratches VTVs, including the ability to do these actions *ad hoc* via the ACTION statement.
- Exports VTVs and MVCs.

How Does LCM Work?

LCM runs as a batch job. You specify the job processing options by creating parameter files with a text editor or by creating configuration files with the LCM Explorer GUI. You can also create an LCM Agent to provide access to TMS information from multiple hosts without the use of shared DASD. LCM provides reports that you can use to monitor resource status, and a log file of LCM actions.

Note – LCM Explorer provides the ability to submit LCM batch jobs via a **Submit...** choice in the context menus for **Run** objects. For more information, see the Explorer help information.

For physical volumes, LCM uses information from the TMS to:

- Determine a volume's scratch status.
- Select scratch volumes for entry into the ACS.
- Determine a volume's last time of reference.
- Determine if a volume is externally managed.
- Manage volumes by data set name or location code.

For VTVs, LCM uses information from the TMS to determine a VTV's scratch status and also extracts information directly from HSC and VTCS to display VSM information and manage VSM resources (the flat file interface is no longer required with NCS and VTCS 4.0.0 and above).

LCM supports multiple TMSs, and checks them in the order you specify. A volume is controlled by the first TMS that references the volume. You can also use LCM to manage volumes that are not under TMS control, and in this case, LCM uses information from the HSC CDS instead.

LCM uses the SMC Uniform User Interface (UI) to communicate with HSC to request scratch updates, ejects, moves, and the last mounted date for data volumes.

You can use the LCM operator commands to do the following:

- Start and stop LCM.
- Display LCM status, ejects completed and remaining, moves completed and remaining, VTV consolidation status, export status, migrate and recall status, and MVC reclaim status.
- Redirect ejects from one CAP to another.
- Pause and resume CAP activity, volume moves, VTV consolidations, exports, migrates and recalls, and MVC reclaims.

FIGURE 1-1 shows an LCM configuration.

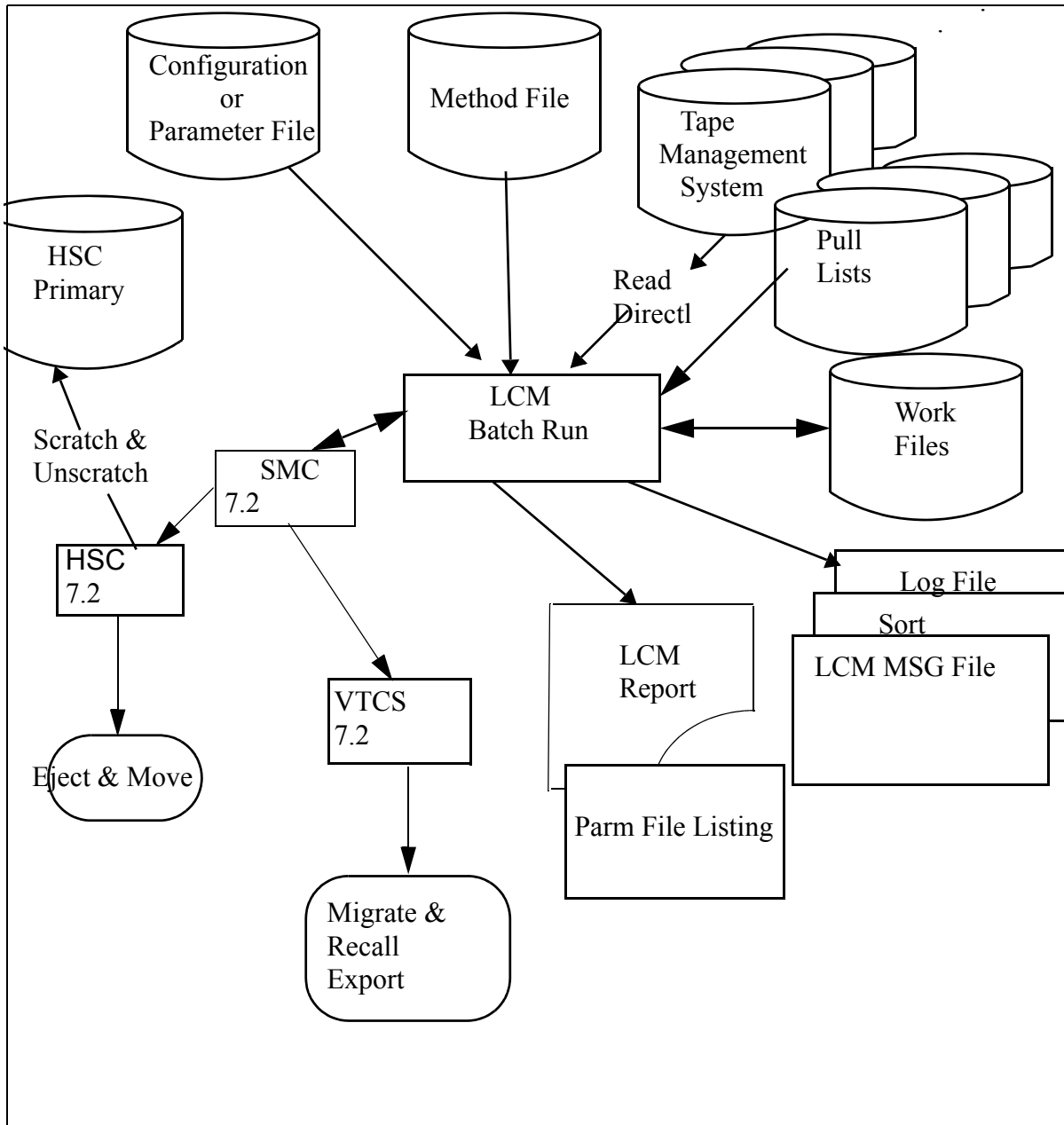

FIGURE 1-1 LCM Processing

LCM Processing

As [FIGURE 1-1 on page 5](#) shows, LCM manages resources as follows:

1. Loads library configuration data from the HSC CDS.
2. Reads the LCM processing options from the parameter file or configuration file.
3. Processes the HSC VOLDEF file.
4. Reads volume information from the CDS.
5. Reads Pull List information.
6. Reads volume information from the TMS and does the following:
 - Marks HSCUNSCR volumes as non-scratch.
 - Does scratch synchronization (for ACS-resident Nearline tape volumes and VTVs managed by a TMS).
7. Reads the Method File for individual volser overrides.
8. Applies content management rules from the LCM configuration.
9. Optionally produces pre-action reports.
10. Ejects and moves physical volumes.
11. Produces post-action reports.
12. Consolidates, migrates, and recalls VTVs.
13. Reclaims MVCs.
14. Exports VTVs and MVCs.

Using LCM to Manage Nearline and VTCS Resources

This chapter tells how to use LCM to manage your Nearline and VTCS resources as described in the following sections:

- [“LCM Usage Considerations” on page 8](#)
- [“LCM Parameter Files” on page 9](#)
- [“Creating an LCM Batch Job” on page 23](#)
- [“Using LCM to Manage Nearline Resources” on page 28](#)
- [“Using LCM to Manage VSM Resources” on page 30](#)

LCM Usage Considerations

As described in [“Using LCM to Manage Nearline Resources” on page 28](#), LCM can help you manage your Nearline system resources. For example, LCM can maintain sufficient levels of scratch volumes, cleaning cartridges, and free cells, and balance or distribute these levels across LSMs in a multi-LSM Nearline system.

The management policies you create with LCM, such as specifying free cell levels, are site-specific decisions. For example, in general, you want to have as many volumes as possible in your LSMs, because free cells are unused storage capacity. However, you need to maintain some free cells to allow cartridge enters and volume movements between LSMs. In addition, in a multi-LSM system, you should probably maintain more free cells in the LSMs where you do most cartridge enters.

For Nearline systems, your planning for LCM should focus on how you use your ACS. How many scratch volumes do you use in an average day? Does your operations staff enter volumes throughout the day or only at the beginning of a day or shift? Do you move volumes to off-site vaults and if so, when do you move these volumes? What times are best for operators to enter and eject volumes? Which are your most active data volumes, and which volumes can reside outside the ACS? Which CAPs do you want to use for volume ejects? To answer these questions, use information from one or more of the following resources:

- If you are considering an ACS purchase, your StorageTek representative can analyze your proposed ACS configuration for LCM usage.
- For an existing ACS, use TMS and HSC reports. For more information about HSC reports, see *ELS Command, Control Statement, and Utility Reference*.
- Use MVS system data. For example, you can use SMF type 15 to estimate the average number of scratch mounts that occur during each shift or during a normal day.
- If you already have LCM, you can use LCM reports to help plan for changes to your Nearline system. See [“LCM Reports” on page 12](#) for more information.

Note – LCM can help make your operations more flexible via the ACTION statement that allow you to do *ad hoc* tasks. For more information, see [“LCM Action Control Statements” on page 181](#).

LCM Parameter Files

LCM parameter files specify how you use LCM to:

- Manage resources, for example:
 - Read the TMS for updated volume scratch status and do HSC scratch synchronization.
 - After a TMS run:
 - Eject volumes destined for vaulting.
 - Ensure sufficient scratch volumes in the ACS.
 - Create free cells before a large number of volume entries.
 - Eject data volumes and request scratch volume enters if scratch or free cell shortages occur.
 - Eject all scratch volumes in a subpool within a managed LSM to retire that subpool.
- Generate LCM reports on Nearline and VSM resources as described in [“LCM Reports” on page 12](#).
- Do *ad hoc* tasks including Nearline volume moves and ejects; VTV consolidations, exports, migrations, and recalls; and scratches and unscratches of Nearline volumes and VTVs.

Note –

- You can, of course, combine functions within single parameter file. For example, one parameter file can do TMS-HSC scratch synchronization, scratch and free cell balancing, ejects for vaulting, and report on the results. The LCM SAMPLIB contains sample parameter files that you can customize for your system; for more information, see [“LCM SAMPLIB Members” on page 389](#).
- You can convert parameter files into an LCM Explorer configuration file, where each parameter file is a different Run object within the configuration file. For more information, start Explorer and see the “Migrating to LCM Explorer” help topics. You can use LCM Explorer to create configuration files instead of parameter files; for more information, see the Explorer help information.
- Prior releases of LCM required that the LCM runs be executed on a server (HSC/VTCS) host, referred to as the Local server. With LCM 7.2, you can execute LCM runs from a SMC Only (or remote) client host with the following requirements:
 - The SMC Only must be able to access all volume data within the CDS for the TapePlex.
 - The TapePlex must be designated via the TAPEPLEX parameter on the EXEC card of the LCM job being executed on the SMC Only system (P=`'TAPEPLEX(tapeplex_name)`).

Note that the LCM Explorer 5.0 and above configuration file has changed to an XML based format. LCM XML based configuration files are compatible with LCM 4.0 configuration files as follows:

- The mainframe component of LCM 5.0 and above can read LCM 4.0 configuration files.
- The 5.0 and above LCM Explorer can read LCM 4.0 configuration files, but it will always save them in the new format.

Caution – StorageTek recommends that you make a backup copy of your production configuration files from prior releases before saving them with the 7.2 and above LCM Explorer in case you need to revert to LCM from the prior level.

LCM Management Control Statements

An LCM parameter file can contain Management control statements that define management policies for your system resources. For example, you can use the **MANAGE** statement to control the level of scratch volumes in your ACS and how they are distributed across LSMs. Control statements also define the reports LCM produces.

The following list describes the LCM Management control statements in their recommended order within a parameter file. As this ordering shows, you should create a resource before you refer to it in another statement. Also note that TMS(s) are read in TMS statement order and a volume is managed by the first statement that references it.

METHOD

The **METHOD** statement defines an LCM management method that can be assigned to nonscratch volumes. LCM provides standard volume management methods, but you can use the **METHOD** statement to define additional methods. For example, you can define management methods that unconditionally eject volumes, eject them only to create free cells, or never eject them.

OPTIONS

The **OPTIONS** statement defines global LCM processing options. For example, the **OPTIONS** statement can specify a title used in all reports, the management method to use for HSC-only and externally managed volumes, and global values for volume scratch status management and defective media removal.

You can create only one **OPTIONS** statement in each parameter file. The **OPTIONS** statement is optional; if not specified, LCM uses the default values.

TMS

The **TMS** statement defines a TMS to LCM and selects processing options for that TMS.

You should create a **TMS** statement for each TMS that controls volumes in the LSMs specified by the **MANAGE** statement.

PULLLIST

The **PULLLIST** statement specifies a list of volumes that an operator must enter for an upcoming production run. LCM uses the pull list to ensure that sufficient free cells exist for these volumes and lists them on an Enter Report.

LOCATION

The **LOCATION** statement specifies a TMS volume location code, the management method, and eject options for data volumes associated with that location. You typically use a **LOCATION** statement to explicitly eject volumes for off-site vaulting.

DATASET

The **DATASET** statement specifies a data set name, management method, and report production for data volumes associated with that data set.

SUBPOOL

The SUBPOOL statement defines a volume subpool that you can use to qualify scratch criteria specified on the MANAGE statement. The SUBPOOL statement can also specify the TMS that manages the volumes in the subpool (or IGNORE for TMS-managed volumes not available to LCM). You can also use the SUBPOOL statement to specify a management method for data volumes in the subpool.

REPORT

The REPORT statement specifies LCM reporting options. You can create multiple REPORT statements in a single parameter file to produce different reports, and you can also specify the same REPORT statements in different parameter files to produce comparison reports for different production runs.

SET METHOD

The SET METHOD statement conditionally assigns management methods to volumes. The SET METHOD statement overrides any method previously assigned to those volumes by any other statement or option.

MANAGE

The MANAGE statement specifies an LSM group and management policies for the volumes and free cells in the LSMs in the group. A MANAGE statement is required for LCM to manage LSM contents.

You can also use the MANAGE statement to define LSM group hierarchies. LCM uses these hierarchies to use available free cells and volumes in LSM groups towards the bottom of the hierarchy to satisfy the requirements of LSM groups towards the top of the hierarchy. LSM group hierarchies can also optimize your use of ExtendedStore™ LSMs by placing them at the bottom level of the hierarchy where they can provide low cost storage of infrequently accessed data volumes and excess scratch volumes and cleaning cartridges.

Similarly, you can use the MANAGE VIRTUAL statement to manage your VSM resources.

UNMANAGED

The UNMANAGED statement specifies an LSM group that is not managed by LCM. LCM does not move, eject, or update HSC scratch status of the volumes in this LSM group. You can, however, produce reports for this LSM group.

LCM Reports

- LCM reports, which can help you manage your system resources, are provided as three types:
 - “LCM Standard Reports” on page 12
 - “LCM Optional Reports” on page 14
 - “LCM Custom Reports” on page 14

LCM also provides report templates that you can customize to easily produce complex reports as described in “REPORT Statement Templates” on page 15.

LCM Standard Reports

LCM standard reports, which are produced by default by an LCM batch job, meet many of your needs with little customization required. For example, to change the standard reports for your site’s needs, you can specify the number of lines per page or, for some reports, the type of totals LCM produces. The standard reports require a **MANAGE** statement in the parameter file, which produces reports with the parameters shown in [FIGURE 2-1](#).

```
report operator ddname(sysprint);
report scrCnt ddname(sysprint) totals(standard);
report nonscrCnt ddname(sysprint) totals(standard);
report cellCnt ddname(sysprint) totals(standard);
report summary ddname(sysprint);
report enter ddname(sysprint);
report eject ddname(sysprint);
report dataset ddname(sysprint) for(report);
report consolidate ddname(sysprint);
report migrate ddname(sysprint);
report recall ddname(sysprint);
report export ddname (sysprint);
```

FIGURE 2-1 Standard Report Definitions

Standard Report Structures

You can suppress the standard reports with the SUPAUTORPT option; for more information, see [“OPTIONS” on page 114](#).

[TABLE 2-1](#) describes the LCM standard reports.

TABLE 2-1 LCM Standard Reports

Report Type	Contents	For more information, see...
CELLCNT	storage cell and volume status for a single LSM, LSM subgroup, LSM group, or entire ACS	“REPORT CELLCNT” on page 277
CONSOLIDATE	VTVs that LCM consolidates onto consolidation MVCs for each consolidation group	“REPORT CONSOLIDATE” on page 281
EJECT	volumes that LCM will eject for each LSM	“REPORT EJECT” on page 284
ENTER	volumes that must be entered for each LSM	“REPORT ENTER” on page 288
EXPORT	VTVs that LCM will export	“REPORT EXPORT” on page 291
MIGRATE	VTVs that LCM will migrate.	“REPORT MIGRATE” on page 295
NONSCRCNT	non-scratch volume counts and ejects, enters, and moves that LCM will do for each LSM	“REPORT NONSCRCNT” on page 298
OPERATOR	describes actions, such as entering and removing volumes, the operator must do to complete LCM content management	“REPORT OPERATOR” on page 305
RECALL	VTVs that LCM will recall.	“REPORT RECALL” on page 308
SCRCNT	scratch volume counts and ejects, enters, and moves that LCM will do for each LSM	“REPORT SCRCNT” on page 311
SUMMARY	summarizes LSM or VSM content and status	“REPORT SUMMARY” on page 316

LCM Optional Reports

LCM Optional Reports, unlike Standard Reports, are not automatically produced; you must specifically request them. Optional Reports have a fixed output, and default and specifiable selection criteria for report contents.

TABLE 2-2 LCM Optional Reports

DATASET	data sets saved on volumes processed by LCM	“REPORT DATASET” on page 321
MULTIPLE	MVC report	“REPORT MULTIPLE” on page 325
PHYSICAL	Nearline volume report	“REPORT PHYSICAL” on page 331
VIRTUAL	VTV report	“REPORT VIRTUAL” on page 347

LCM Custom Reports

Custom Reports, which must be explicitly requested, provide both a wide range of selection criteria and output formats that can be ordered and sorted in many ways. [TABLE 2-3](#) describes the LCM custom reports.

TABLE 2-3 LCM Custom Reports

Report Type	Contents	For more information, see...
LSM	customized reports of LSM content and status	“REPORT LSM” on page 354
MVC_VTV	customized reports of MVCs and VTVs	“REPORT MVC_VTV” on page 356
VOLUME	customized reports of LCM-managed volumes	“REPORT VOLUME” on page 358

REPORT Statement Guidelines

The following are guidelines for REPORT statements:

- Reports print in the order that you code REPORT statements in a parameter file.
- You can do report-only runs for only the LSM, MVC_VTV, and VOLUME custom reports, and a MANAGE statement is not required in the parameter file.
- Specify FREE=CLOSE on the SYSPRINT DD statement to allow the report to print while LCM is still executing.
- Use the DDNAME(*ddname*) or SYSOUT(*class*) parameter to specify the report destination (*ddname* or *SYSOUT* class).
- Use the TITLE(*text*) parameter to specify the title for each page of the report (maximum 70 characters). This title is printed below the OPTIONS TITLE text if specified.

REPORT Statement Templates

The REPORT PHYSICAL, REPORT MULTIPLE, REPORT VAULT, and REPORT VIRTUAL statements generate an expanded listing in the parameter file showing the statements created for the appropriate Custom Report as described in Table 2-4.

TABLE 2-4 Expanded Listings Custom Reports

This Report statement generates...	...an expanded listing with this Report statement
REPORT MULTIPLE DETAIL	REPORT MVC_VTV
REPORT MULTIPLE	REPORT VOLUME
REPORT PHYSICAL	REPORT VOLUME
REPORT VAULT	
REPORT VIRTUAL	REPORT VOLUME

If you want to customize your reports more than is available with parameters on these reports, you can copy the expanded listings for the Custom Report to use as a template.

LCM ACTION Control Statements

The LCM ACTION statements do *ad hoc* actions, including Nearline volume moves and ejects; VTV consolidations, exports, migrations, and recalls; and scratches and unscratches of Nearline volumes and VTVs. The ACTION statements let you select volumes (physical or virtual) using any combination of fields and specify actions for the selected volumes.

The ACTION statement works alone or in combination with other LCM statements. If an LCM file contains a mixture of ACTION statements and MANAGE statements, LCM first does actions specified by the ACTION statements, then does whatever additional actions, if any, are required to satisfy the MANAGE statements. For more information, see [“LCM Action Control Statements” on page 181](#).

Parameter File Syntax Requirements

LCM parameter files have the following syntax requirements:

- Use columns 1-72 are for control statements.
- Begin each statement with the control statement name followed by parameters.
- Use spaces to separate the control statement name and parameters. Use blanks or commas to separate parameters.
- End each control statement with a semi-colon (;).
- Control statements can flow across lines anywhere spaces are permitted.
- You can specify control statements in lowercase, uppercase, or mixed case.
- Write comments in any of the following styles:
 - `/* Comment */` Anywhere spaces are allowed. This style can span multiple lines.
 - `*` Everything on this line.
 - `.parms; //` Anything from double slashes to end of line.

Subparameter Data Types

Data types and coding requirements for control statement subparameter values are defined as follows.

Character Data

alphabetic character

a letter A, B, ..., Z, in uppercase or lowercase, or a national character (#, @, or \$).

numeric character

a decimal digit 0, 1, ..., 9.

alphanumeric character

an alphabetic character or a numeric character.

special character

any character other than an alphanumeric character, including the blank character.

Numeric Data

decimal number

a sequence of numeric characters.

hexadecimal number

a base sixteen number; a sequence of characters in which each character is a numeric character or a letter A, B, C, D, E or F, in uppercase or lowercase.

LCM converts lowercase letters in a hexadecimal number to uppercase.

Textual Data

character string

any sequence of one or more alphanumeric or special characters.

If a character string contains a special character, put the string in single quotes ('). You may also code a null string. A null string is a character string that represents no characters, and is coded as two consecutive single quotes.

The length of a character string is equal to the number of characters represented by the string. The beginning and ending single quotes of a quoted string are not regarded as string data and do not count toward the length of the string.

LCM converts lowercase letters in a character string to uppercase letters unless the string is put in single quotes; LCM does not alter the case of characters coded in a quoted string.

A character string must be wholly contained on a single line of a parameter file.

If a subparameter value must be coded as a numeric value, a data set identifier, or a volser range, do not code the value as a quoted string.

Represent a single quote in a character string by coding two consecutive single quotes. The following is an example of how to code a character string that contains single quotes.

Example of Coding Single Quotes in a Character String

The string:

Tape 'vault'

must be coded as:

' Tape "vault"

data set identifier

a character string that represents the names of one or more nongeneration data sets or represents the names of one or more generation data groups.

The true name of a nongeneration tape data set consists of a sequence of one or more qualifiers, each separated by periods. The true name of a generation tape data set consists of a base name and a generation identifier. A base name consists of a sequence of one or more qualifiers, each separated by periods, and identifies a family of cataloged data sets called a generation data group (GDG). The data sets of a GDG are called generation data sets.

A generation identifier is a suffix qualifier for a base name and has the form GnnnnVnn. The absolute generation number, nnnn, is a four-digit decimal number in the range 0001 through 9999. The version number, nn, is a two-digit decimal number in the range 00 through 99. A generation identifier identifies a version of a specific generation data set that belongs to the GDG identified by the base name. Only generation data set names have a generation identifier as a suffix qualifier.

The true name of a nongeneration data set may be coded as a data set identifier. For a generation data group, only the GDG base name may be coded as a data set identifier.

A data set identifier must be coded as a sequence of one or more qualifiers. If the sequence consists of two or more qualifiers, separate each qualifier by a period (.). Do not code a data set identifier as a string enclosed by single quotes.

A qualifier must be coded as a string that ranges in length from one to eight characters. Only characters that can be coded in an OS data set name may be coded as characters of a qualifier. For more information about OS data set names, refer to the IBM publication *JCL Reference* or *MVS Data Administration Guide* for your system.

Letters coded in a qualifier may be coded as lowercase or uppercase letters. LCM converts lowercase letters in a qualifier to uppercase letters during execution. Do not code a qualifier as a string enclosed by single quotes.

By using wild cards, you can code a single data set identifier that represents more than one data set name. There are wild cards to represent qualifier characters, qualifier suffixes, whole qualifiers, sequences of qualifiers, and a whole data set name.

- The percent sign wild card (%) represents any single character of a qualifier.

Each percent sign coded in a qualifier counts toward the length of the qualifier as one character.

- The asterisk wild card (*) can represent any qualifier or all suffixes of a qualifier.

An asterisk coded as a whole qualifier represents any qualifier. An asterisk coded as a qualifier suffix represents all valid suffixes of the qualifier, including no suffix at all.

An asterisk coded in a qualifier counts toward the length of the qualifier as one character, and may only be coded as the last character of a qualifier.

- The double asterisk wild card (**) can represent any sequence of qualifiers or all data set names.

A double asterisk coded as a qualifier sequence may only be coded at the end of a data set identifier and represents all valid sequences of qualifiers, including no sequence at all. A double asterisk coded as a whole data set identifier represents all data set names.

A double asterisk coded in a data set identifier counts toward the length of the data set identifier as two characters.

A data set identifier that does not contain a wild card represents either the true name of a specific nongeneration data set or the base name of a specific generation data group.

Unless a control statement syntax definition indicates otherwise, a data set identifier may consist of at most 44 characters, including periods, and may contain wild cards.

Shown in [FIGURE 2-2](#) are several examples of valid data set identifiers.

```
SYS1.ABCDEFGH.DATA
SYS1.%%%%%%%%%%.DATA
SYS1.%%%%%%%%%%*.DATA
SYS%.A%C%E%G%.DATA
SYS%.ABCD*.DATA
SYS%*.DAT*
SYS*.*.D%T*
SYS*.*.D%T*.**
SYS*.**
**
```

FIGURE 2-2 Examples of Valid Data Set Identifiers

Shown in TABLE 2-5 are several examples of improperly coded data set identifiers.

TABLE 2-5 Examples of Improperly Coded Data Set Identifiers

Invalid Data Set Identifier	Reason Identifier is Invalid
BACKUP.VOL123	A qualifier is missing.
BACKUP.VOL123.	A qualifier is missing.
BACKUP.%%%%%%%%%%.VOL123	There are more than eight characters coded in a qualifier.
BACKUP.%%%%%%%%%%*.VOL123	There are more than eight characters coded in a qualifier.
BACKUP.*TAPE.VOL123	The asterisk is not coded as the last character of a qualifier.
BACKUP.**.VOL123	The double asterisk is not coded at the end of the data set identifier.
BACKUP**	The double asterisk is not coded as a qualifier.
BACKUP1.TAPE.VOL123.G0255V00	The data set identifier contains a generation identifier.
'BACKUP1.TAPE.VOL123'	The data set identifier is enclosed by single quotes.

volser number

identifies the volume serial number of a specific tape volume.

Code a volser number as you would code any valid OS tape volume serial number. If you code a volser number that contains a special character or a lowercase letter, put the volser number in single quotes (').

LCM converts lowercase letters coded in a volser number to uppercase letters unless the volser number is put in single quotes; LCM does not alter the case of characters coded in a quoted volser number.

The number of characters coded in a volser number must not exceed six. LCM stores all volser numbers internally as six-character volser numbers; if necessary, LCM pads a volser number with trailing blanks to convert it to a six-character volser number. For example, LCM would store the volser number 0000 internally as 0000bb (b represents the blank character).

volser range

defines a range of consecutive tape volume serial numbers.

Code a volser range as two volser numbers separated by a dash (-). The volser number coded ahead of the dash represents the first volume serial number of the range, and the other volser number represents the last volume serial number of the range. Do not code a volser range as a string enclosed by single quotes.

Both volser numbers of a range must contain a sequence number portion and may optionally contain other characters. LCM regards the rightmost decimal numeric field within a volser as the sequence number position.

Code each sequence number portion as a one- to six-digit decimal number. The sequence number portion of both volser numbers must have the same number of digits and must be coded within the volser numbers at the same position. The magnitude of the first sequence number of a range must not be greater than the magnitude of the last sequence number of the range.

Other characters coded optionally in the volser numbers of a range must correspond exactly, by position and by value.

Shown in [TABLE 2-6](#) are several examples of valid volser ranges.

TABLE 2-6 Examples of Valid Volser Ranges

Valid volser range	Sequence number portion	
	First volser number	Last volser number
X0Z555-X0Z777	555	777
X00Z30-X00Z60	30	60
X444ZZ-X800ZZ	444	800
000VOL-999VOL	000	999
000000-200000	000000	200000
6000-6500	6000	6500
'vol1id'-'vol9id'	1	9

Shown in [TABLE 2-7](#) are several examples of improperly coded volser ranges.

TABLE 2-7 Examples of Improperly Coded Volser Ranges

Invalid Volser Range	Reason Volser Range is Invalid
2000-0000	The starting sequence number (2000) is of a greater magnitude than the ending sequence number (0000).
VOL1-VOL100	The sequence numbers (1 and 100) do not have the same number of digits.
HH00XX-H99HXX	The sequence numbers (00 and 99) are not at the same positions; consequently, the non sequence number characters do not correspond.
VOL001-TAP999	The non sequence number characters (VOL and TAP) are not identical.
V00L00-V00X00	The non sequence number characters (L and X) are not identical.
X1Z555-X2Z777	The non sequence number characters (1 and 2) are not identical.
VOLAAA-VOLZZZ	Neither volser number has a sequence number portion.
'X0Z555-X0Z777'	The volser range is enclosed by single quotes.

For information about using alphabetic volsers, see [“ELS Alphabetic Volsers” on page 395](#).

LCM Fields

As described in *LCM Quick Reference*, LCM provides you with a panoply of fields you can use to generate reports, supercharge your ACTION statements, and so forth. Anywhere a field occurs, you can also code the SUBSTR function to reference a portion of a field as follows:

SUBSTR(*field,position[,length]*).

field

The field from which to obtain a substring. This must be a field of type character.

position

The starting position of the substring within field. Position is required and must be between 1 and the length of the field's value.

length

The length of the substring within field. Length is optional. If length is not specified, the remainder of the value starting at position is returned.

Creating an LCM Batch Job

You create and submit an LCM batch job, which specifies a parameter file or Explorer configuration file, to specify how LCM manages your system resources and which reports LCM produces. You typically run LCM batch jobs at the following times:

- After the daily TMS run to eject volumes for vaulting, establish scratch volume levels, and establish free cell levels.
- After entering volumes, to synchronize scratch status.
- To alleviate scratch or free cell shortages.
- To retire a subpool.
- To eject volumes associated with specific data sets.
- To eject volumes for placement in assigned vault locations.
- To provide service levels.
- To produce before and after LSM contents reports.

For more information about creating an LCM batch job, see the following sections:

- [“JCL EXEC Statement” on page 24](#)
- [“Required and Optional JCL DD Statements” on page 25](#)
- [“Using LCM to Manage Nearline Resources” on page 28](#)
- [“Using LCM to Manage VSM Resources” on page 30](#)

Note – SAMPLIB member LCMRUN is a sample LCM batch job. LCM Explorer 5.0.0 and above provides the ability to submit LCM batch jobs via a **Submit...** choice in the context menus for **Run** objects. For more information, see the Explorer help information.

JCL EXEC Statement

This section describes the JCL EXEC statement used to submit an LCM batch job.

Syntax

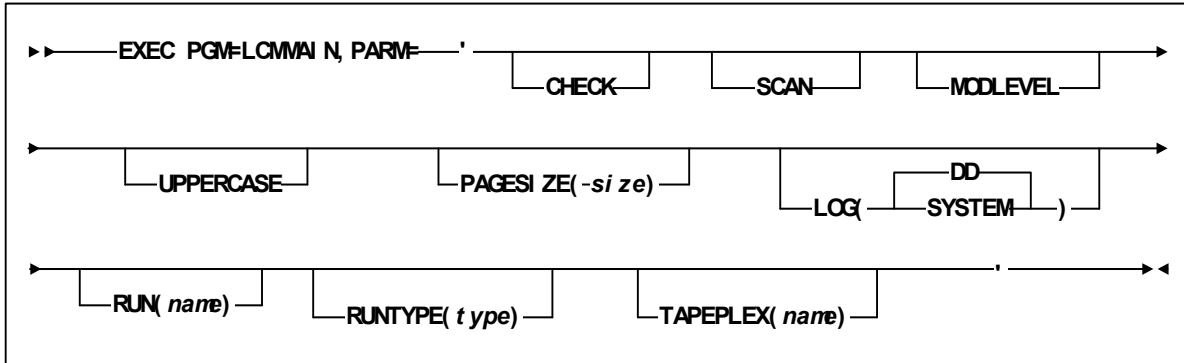

JCL EXEC Statement Syntax

Parameters

EXEC PGM=LCMMAIN

invokes the LCMMAIN program to run an LCM batch job.

PARM='parameter,parameter,...'

specifies a comma or blank delimited list (enclosed in single quotes) of one or more of the following job execution parameters.

CHECK

identical to the OPTIONS statement CHECK parameter, specifies that LCM:

- Manages LSMs as defined by the control statements in the parameter file used for this batch job, but does not eject volumes or modify the HSC CDS (including scratch synchronization).
- Produces reports and creates the Eject File.

If you specify both the CHECK and SCAN options, LCM executes in SCAN mode.

SCAN

identical to the OPTIONS statement SCAN parameter, specifies that LCM scans control statement syntax and creates a Parameter File listing with any errors, but does not perform any management action.

If you specify both the CHECK and SCAN options, LCM executes in SCAN mode.

MODLEVEL

specifies that LCM logs a message for each LCM module loaded for execution. This message describes the module's maintenance level.

UPPERCASE

specifies that LCM produces reports in all uppercase; the default is mixed case.

PAGESIZE

specifies the number of lines per page for LCM reports.

size

the number of lines per page. Valid values are 20 to 1000 and the default is 58.

LOG

specifies where LCM writes log messages.

DD

specifies that LCM writes log messages to ddname LCMLOG if specified in the job JCL. Otherwise, LCM writes log messages to ddname LCMMSG. DD is the default.

SYSTEM

specifies that LCM writes log messages to the system console.

RUN

specifies that LCM executes an Explorer RUN object from the Explorer configuration file allocated to ddname LCMCFG. RUN is optional; only specify RUN if you are using an Explorer configuration file.

name

specifies the 1 to 10 character name of the Explorer RUN object.

RUNTYPE

defines a variable for comparisons in the SET METHOD statement.

runtype

specifies the 1 to 10 character name of the variable. The default is STANDARD.

TAPEPLEX

specifies the name of TapePlex to be used by LCM. This parameter is only required in a situation where two TapePlexes are defined to the host where LCM is executing and both TapePlexes have a library server defined as being on the same host.

name

specifies the TapePlex name.

Required and Optional JCL DD Statements

STEPLIB

specifies LCM, HSC, SMC, VSM and sort load libraries; required only if these libraries are not in the MVS linklist. By default, the LCM, HSC, SMC, and VSM load libraries are installed as data sets LCM.SEALINK, SLS.SEALINK, SLS.SEALINK and SWS.SEALINK respectively, and the sort package as SYS1.SORTLIB. The sort load library must be APF authorized.

LCMTMSDB

specifies the default TMS data base if not specified on the TMS statement, and is only required if you do *not* use:

- The TMS statement to dynamically allocate to a TMS by data set name.
- LCM Agent to obtain TMS information.

Because the TMS statement has been updated to support dynamically allocating to a TMS by DSN or obtaining TMS information through the use of the LCM Agent, which uses dynamic allocation to get to the TMS, the LCMTMSDB DD statement is no longer required.

This DD statement is not used if you have specified the NOTMS parameter of the OPTIONS statement.

LCM defines five input buffers for the LCMTMSDB data set by default. LCM batch job performance might be improved by defining a larger number of input buffers. Code the DCB BUFNO subparameter for the LCMTMSDB DD statement to specify the desired number of input buffers.

If you create an LCMTMSDB statement:

- For CA-1 and CA-TLMS, ddname LCMTMSDB should point directly to your TMS catalog or volume master file, respectively.
- For DFSMSrmm, ddname LCMTMSDB should point to a DFSMSrmm extract file. The extract file can be produced in another job or in the LCM run job.
- For other TMSs, the TMS CUSTOM or TMS COMMON interface is required. Contact your TMS vendor to determine how LCM should be set up with the vendor's TMS.

Use DCB=BUFNO=255 if your TMS catalog does not contain blocked records.

LCMSECUR

only required to specify the LCM Agent security file. For example:

```
//LCMSECUR DD DSN=<agent access code file>,DISP=SHR
```

LCMMSG

specifies the LCM message file data set. If not specified, LCM automatically allocates an LCMMSG DD statement using the default SYSOUT class.

SORTMSG

specifies where messages from your sort software appear.

SYSRPT

specifies where LCM writes certain reports. StorageTek recommends that you specify FREE=CLOSE to let these reports print while and LCM job is still running.

If not specified, LCM automatically allocates a SYSRPT DD statement using the default SYSOUT class.

LCMLOG

specifies the LCM log file data set. If not specified, LCM writes log output, along with the message file, to ddname LCMMSG.

SYSTEM

specifies where LCM writes client error messages. If not specified, LCM automatically allocates an SYSTEM DD statement using the default SYSOUT class. SYSTEM is only required if you use an LCM Agent for remote TMS access.

LCMPARM

specifies the LCM parameter file data set. LCMPARM is required if you do not specify the RUN parameter on the EXEC statement; see ["JCL EXEC Statement" on page 24](#).

You can specify either LCMCFG or LCMPARM but not both.

LCMCFG

specifies the Explorer configuration file data set. LCMCFG is required if you specify the RUN parameter on the EXEC statement; see [“JCL EXEC Statement” on page 24](#). Specify FREE=CLOSE to let Explorer update the configuration file when an LCM job does not have the configuration data set allocated.

You can specify either LCMCFG or LCMPARM but not both.

LCMMTHIN

specifies the LCM method file data set; only required if the OPTIONS statement specifies the METHODFILE parameter.

LCMPULL

specifies the default LCM pull list file data set if not specified on the PULLLIST statement. This statement is not required if you do not specify a PULLLIST statement.

Various Report DD Statements

DD statements as specified by the DDNAME parameter of REPORT statements you have coded in your parameter file; for more information, see [“LCM Management Control Statements” on page 85](#).

LCMLIB

specifies the LCM template library data set; only required if using a customer-defined report template.

Using LCM to Manage Nearline Resources

Member LCMRUN in the LCM SAMPLIB is sample JCL to run an LCM batch job for Nearline systems; for more information, see [“LCM SAMPLIB Members” on page 389](#).

LCM produces printed output whose DCB is LRECL=255,RECFM=VBA. If you direct the output to a disk or tape data set, you should also specify the data set block size.

The Eject Report lists the location name, volume serial number, and slot number for each cartridge ejected. The Enter Report lists volumes (by volses, location name, and slot, if available) that must be entered, including data volumes required for upcoming production runs flagged by PULLIST statement parameters. Enter these volumes after eject processing (which creates needed free cells) completes.

LCM picks scratch volumes for entry and lists their volses on the Enter Report if:

- You specify the PICKSCR parameter on the OPTIONS statement,
- Additional scratch volumes are required,
- Non-library scratch volumes are available.

If you do not specify the PICKSCR parameter, you must select scratch volumes by another method.

The Scratch Counts Report lists the total number of scratch volumes to be entered for each tape group. If you specify the PICKSCR parameter on the OPTIONS statement and there are insufficient non-library scratch volumes available, the Operator Report shows this condition. In this case, you may need to make more physical scratch volumes available.

If scratch volumes are entered through a CAP, HSC enters those volumes as nonscratch volumes unless you specify SCRATCH on the ENTER command. You can also use LCM to mark newly entered volumes as scratch.

The total number of scratch volumes to be entered is listed on the Scratch Report under the appropriate tape group.

The ACTION statement does *ad hoc* actions, including Nearline volume moves and ejects. The ACTION statement lets you select volumes (physical or virtual) using any combination of fields and specify actions for the selected volumes.

The CLEARFROZENPANELS parameter of the OPTIONS statement specifies that LCM removes volumes from frozen panels in managed LSMs. For more information, see [“OPTIONS” on page 114](#).

HSC usually ejects used cleaning cartridges when they reach maximum use count. If you are running a darkened data center, however, you may want to schedule all ejects for a specific time as follows:

1. Use the following HSC command to mark these cleaning cartridges as not usable without ejecting them:

```
.MNTD EJctauto(OFF)
```

2. Write an ACTION EJECT statement that uses the clean and notuseable fields to eject these cleaning cartridges when you want. For example:

```
action eject when(clean and notuseable)
```

```
    ejmsg('Spent Cleaning Cartridges')
```

```
    ejcap(000);
```

For more information, see ["ACTION EJECT" on page 195](#).

Using LCM to Manage VSM Resources

LCM interoperates with VSM as described in the following sections:

- [“General Guidelines” on page 30.](#)
- [“Using LCM to do VTV Consolidations” on page 31](#)
- [“Using LCM to do Migrates and Recalls” on page 32](#)
- [“Using LCM to do Exports” on page 33](#)

General Guidelines

The following are guidelines for using LCM with all versions of VTCS:

- You can define subpools that contain VTVs by specifying `MEDIA(VIRTUAL)`; for more information, see [“SUBPOOL” on page 140.](#)
- To synchronize VTV scratch status, you specify the `OPTIONS SYNCVTV` keyword; for more information, see [“OPTIONS” on page 114.](#) If you specify the `SYNCVTV` keyword, note the following:
 - `SYNCVTV` does not update the scratch status of VTVs not defined to the TMS.
 - StorageTek recommends that you define VTV ranges in scratch status; for more information, see the `VTVVOL` statement of the `CONFIG` utility in *ELS Command, Control Statement, and Utility Reference*. If you do not define VTVs as scratch, you must use `ACTION SCRATCH` to scratch these volumes.
 - You use the `DELSCR` parameter of the `MGMTclas` statement to specify whether VSM deletes scratched VTVs from the VTSS; for more information, see *ELS Command, Control Statement, and Utility Reference*.
 - Specifying `DELSCR YES` causes VTCS to delete scratched VTVs from the VTSS, which frees VTSS buffer space. `DELSCR YES`, however, eliminates the ability to recover data from scratched VTVs.
- Normally, if the TMS marks a VTV as scratch, `DELSCR` is set to `YES`, and you specify the `OPTIONS SYNCVTV` keyword, the VTV is deleted from the VTSS on scratch and cannot be recovered. However, in LCM 6.0 and above, there is a default grace period of 1 hour (or a user-set time) when performing scratch synchronization for VTVs. This means that any VTV selected during this period of time will be excluded from scratch synchronization to reduce exposure to an inadvertent scratch of a VTV created during the scratch synchronization run.
- The LCM Volume Report provides additional fields to report VSM information; for more information, see [“REPORT VOLUME” on page 358.](#)
- The following standard LCM reports also include VSM information, where LCM reports the *lsm-id* as `VSM` and the *acs-id* as `VS`:
 - The Scratch Counts Report, where scratch counts for VTVs are denoted by a “+” suffix.
 - The Nonscratch Counts Report.
 - The Summary Report, which includes VTV scratch and nonscratch counts. Free cells, which are not meaningful for VTVs, are always reported as zero.

The Cell Count and Operator Reports *do not* include VSM information.

- You can use the SET METHOD statement to conditionally assign management methods to unexpired or nonscratch MVCs. To ensure that LCM does not eject MVCs, assign them a management method of NEVEREJECT. For example:
SET METHOD WHEN(MVC) NEVEREJECT;
For more information, see [“SET METHOD” on page 134](#).
- You can use the SET METHOD statement, which provides additional fields for MVCs, to conditionally assign management methods to unexpired or nonscratch MVCs. For more information, see [“SET METHOD” on page 134](#).

Using LCM to do VTV Consolidations

The following procedure tells how to do VTV consolidations.

Note – You can also use the ACTION CONSOLIDATE statement to do *ad hoc* VTV consolidations. The ACTION statement lets you select volumes (physical or virtual) using any combination of fields and specify actions for the selected volumes. For more information, see [“ACTION CONSOLIDATE” on page 182](#).

To do VTV consolidations:

1. **Ensure that the parameter file for the consolidation job contains a MANAGE VIRTUAL statement.**

For more information, see [“MANAGE VIRTUAL” on page 105](#).

2. **Create a method that specifies the consolidation group on the METHOD CONSOLIDATE parameter.**

For more information, see [“METHOD” on page 106](#).

3. **Use another LCM statement to assign the consolidation method.**

For example, you can use the DATASET statement to assign a consolidation method to all data sets with a specific high-level qualifier. For more information about assigning methods, see [“Usage” on page 138](#).

4. **Use the LCM operator commands to monitor and control the consolidation job.**

For more information, see [“LCM Operator Commands” on page 379](#).

5. **Use the Consolidation Report to display the results of the consolidation job.**

For more information, see [“REPORT CONSOLIDATE” on page 281](#).

Using LCM to do Migrates and Recalls

The following procedure tells how to do VTV migrates and recalls.

VTVs can be included on pull lists, which is useful if you want to pre-stage VTVs for a specific job or batch processing window. For more information, see [“PULLLIST” on page 131](#).

Note – You can also use the ACTION MIGRATE and ACTION RECALL statements to do *ad hoc* VTV migrates and recalls. The ACTION statement lets you select volumes (physical or virtual) using any combination of fields and specify actions [“ACTION MIGRATE” on page 211](#) and [“ACTION RECALL” on page 226](#).

To do VTV migrations and recalls:

1. **Ensure that the parameter file for the migration or recall job contains a MANAGE VIRTUAL statement.**

For more information, see [“MANAGE VIRTUAL” on page 105](#).

2. **Create a method that specifies migration or recall parameters.**

For more information, see [“METHOD” on page 106](#).

3. **Use another LCM statement to assign the migration or recall method.**

4. **For example, you can use the DATASET statement to assign a migration or recall method to all data sets with a specific high-level qualifier. For more information about assigning methods, see “Usage” on page 124.**

Use the LCM operator commands to monitor and control the migration or recall job.

For more information, see [“LCM Operator Commands” on page 379](#).

5. **Use the Migration and Recall Reports to display the results of the job.**

For more information, see [“REPORT MIGRATE” on page 295](#) and [“REPORT RECALL” on page 308](#).

Using LCM to do Exports

The following procedure tells how to do exports.

Note – You can also use the ACTION EXPORT statement to do *ad hoc* exports. The ACTION statement lets you select volumes (physical or virtual) using any combination of fields and specify actions for the selected volumes. For more information, see [“ACTION EXPORT” on page 203](#).

To do exports:

1. **Ensure that the parameter file for the export job contains a MANAGE VIRTUAL statement.**

For more information, see [“MANAGE VIRTUAL” on page 105](#).

2. **Create a method that specifies export parameters.**

For more information, see [“METHOD” on page 106](#).

3. **Use another LCM statement to assign the export method.**

For example, you can use the DATASET statement to assign an export method to all data sets with a specific high-level qualifier. For more information about assigning methods, see [“Usage” on page 124](#).

4. **Use the LCM operator commands to monitor and control the export job.**

For more information, see [“LCM Operator Commands” on page 379](#).

5. **Use the Export Report to display the results of the job.**

For more information, see [“REPORT EXPORT” on page 291](#).

Using LCM with Your TMS

This chapter tells how to use LCM with the TMSs described in the following sections:

- [“Using LCM with CA-1” on page 38](#)
- [“Using LCM with DFSMSrmm” on page 48](#)
- [“Using LCM with CA-TLMS” on page 57](#)
- [“Using LCM with a Custom TMS Interface Module” on page 67](#)
- [“Using LCM with Control-T” on page 66](#)
- [“Using LCM with Open Systems Clients” on page 73](#)

See also [“General Guidelines for Defining TMSs” on page 36](#) and [“Setting Up the LCM Interface to Any TMS” on page 37](#).

General Guidelines for Defining TMSs

- Use the following guidelines to define TMSs to LCM:
- Specify TMS statements before you reference them by TMS name in other statements.
- You can specify an unlimited number of TMS statements in a parameter file; LCM checks multiple TMS statements for volume information in their order in the parameter file. If a volume is defined in multiple TMSs, LCM uses information from the first TMS statement that applies, unless the TMSNAME parameter of the SUBPOOL statement specifies otherwise. Therefore, if you specify multiple TMS statements, StorageTek recommends that you specify the TMS on the SUBPOOL TMSNAME parameter. For more information, see [“SUBPOOL” on page 140](#).
- Multi-volume data sets cannot span TMSs. If LCM finds volumes with the same controlling data set name in multiple TMSs defined to LCM, LCM considers these volumes as belonging to different data sets.
- If you do not specify any TMS statements or the OPTIONS NOTMS parameter, LCM uses the defaults from the TMS CA1 statement.
If you specify the OPTIONS NOTMS parameter to indicate that you are running without a TMS, you cannot specify any TMS statements.

▼ Setting Up the LCM Interface to Any TMS

The following procedure tells how to set up the LCM interface to any TMS. See the appropriate section in this Chapter to complete specific setup for your TMS.

To set up the LCM interface to a TMS:

- 1. If your system has multiple MVS hosts without shared DASD, ensure that the LCM Agent started task is running on the MVS system where your TMS catalog resides.**

For more information, see *LCM Maintenance Guide*

- 2. Create a TMS statement to define your TMS to LCM.**

See [“LCM Management Control Statements” on page 85](#).

- 3. If your TMS statement specifies a ddname for the TMS tape catalog, create a DD statement for the TMS tape catalog.**

For more information, see [“Creating an LCM Batch Job” on page 23](#).

Using LCM with CA-1

This section tells how to use LCM with CA-1 as described in the following sections:

- [“Using LCM to Manage CA-1 Scratch Subpools” on page 39](#)
- [“Using LCM with the CA-1 Vault Management System” on page 41](#)
- [“Using LCM to Manage Externally Managed Volumes” on page 45](#)
- [“Using LCM to Manage Expired Volumes” on page 45](#)
- [“How LCM Processes Specific OPTIONS Statement Parameters For CA-1” on page 46](#)

▼ Using LCM to Manage CA-1 Scratch Subpools

LCM can manage the LSM scratch volume supply for CA-1 scratch subpools. LCM can also select for entry scratch volumes that are defined to the CA-1 system. For CA-1, LCM considers a volume as scratch if the TMC indicates the volume is scratch, not marked deleted, not out-of-area, and not marked defective. The following procedure tells how to define a CA-1 scratch subpool to LCM. Also see [“Managing a Single Scratch Volume Subpool” on page 39](#) and [“Managing Multiple Scratch Volume Subpools” on page 40](#).

To define a CA-1 scratch subpool to LCM:

1. Create an LCM OPTIONS statement to define global processing options for CA-1.

LCM can pick scratch volumes for entry as specified by the PICKSCR parameter of the OPTIONS statement. LCM reads the CA-1 TMC and selects volumes for entry that are usable, not out-of-area, and that have the lowest volume open counts. For more information, see [“OPTIONS” on page 114](#).

2. Create an LCM SUBPOOL statement to define a subpool that corresponds to a CA-1 subpool.

The CA-1 SCRPOOL control statement defines the subpool to CA1. For more information on the LCM SUBPOOL control statement, see [“SUBPOOL” on page 140](#).

Ensure that the volsers specified on the SCRPOOL statement match those specified on the SUBPOOL statement. StorageTek recommends you use the same subpool name in both statements.

3. Create an LCM MANAGE statement to define the scratch criteria.

LCM can ensure that a sufficient supply of scratch volumes resides in the ACS as specified by the NUMSCR parameter of the MANAGE statement. LCM also can eject excess scratch volumes of LSM scratch subpools as specified by the CMAXSCR and AMAXSCR parameters of the MANAGE statement. LCM reads the CA-1 TMC and selects those volumes for ejection that have the highest volume open counts. For more information, see [“MANAGE PHYSICAL” on page 96](#).

▼ Managing a Single Scratch Volume Subpool

If your configuration does not use multiple CA-1 scratch subpools, LCM can manage the entire LSM scratch volume supply as a single subpool. You can either define an LCM subpool or use the predefined GENERAL subpool.

[FIGURE 3-1](#) shows an example of a MANAGE statement to manage the entire LSM scratch volume supply as the GENERAL subpool.

```
manage lsmid(00:00)
numscr.general(150) /* Ensure at least this many */
cmxscr.general(175) ; /* Don't remove below this limit */
```

FIGURE 3-1 Example of Managing a Single CA-1 Scratch Pool with LCM

▼ Managing Multiple Scratch Volume Subpools

FIGURE 3-2 shows CA-1 SCRPOOL control statements that define scratch subpools, 100000-199999, PAYROLL, and MKTG.GROUP.

```
SCRPOOL=100000-199999,RANGE=100000-199999
SCRPOOL=PAYROLL,RANGE=705000-705999
SCRPOOL=MKTG.GROUP,RANGE=450000-705999
```

FIGURE 3-2 Example of Multiple CA-1 Scratch Subpool Definitions

FIGURE 3-3 shows LCM SUBPOOL and MANAGE statements that define the CA-1 scratch subpools shown in FIGURE 3-2.

```
subpool name('100000-199999') serials(100000-199999);
subpool name(payroll) serials(705000-705999);
subpool name('mktg.group') serials(450000-705999);

manage lsmid(00:00)
  numfree(20)
  numscr .'100000-199999'( 75 )
  cmaxscr.'100000-199999'( 100 )
  numscr .payroll ( 60 )
  cmaxscr.payroll ( 100 );

manage lsmid(00:01)
  numfree(125)
  numscr .'100000-199999'( 75 )
  cmaxscr.'100000-199999'( 100 )
  numscr .'mktg.group' ( 150 )
  cmaxscr.'mktg.group' ( 250 );
```

FIGURE 3-3 Example of Defining Multiple CA-1 Scratch Subpools for LCM

Note – You can define multiple scratch subpools to be managed by LCM even if your site does not use multiple CA-1 scratch subpools. Multiple scratch subpools can be used, for example, to maintain LSM scratch volume supplies for different user groups or applications. These user groups or applications must follow site volser use conventions for this approach to work effectively.

▼ Using LCM with the CA-1 Vault Management System

The CA-1 Vault Management System (VMS) schedules volumes for storage in vaults. The CA-1 system administrator creates vault definitions and a vaulting schedule for the VMS. LCM can interface with the VMS to help manage volumes in an LSM that is under VMS control.

To maintain VMS integrity with LCM, follow VMS guidelines and the guidelines in [“Using LCM to Manage Vault Rotation” on page 44](#).

▼ Defining VMS Vault Names to LCM with LOCATION Statements

VMS assigns a vault name to a volume when VMS schedules the volume for vaulting and records this assignment in the TMC as the volume out-of-area code. VMS allows both user-defined and VMS-defined vault names, which are the blank or null vault name, LIB, and any nonblank vault name that begins with a blank character, for example, ' LIB' or ' VMS'. The VMS assigns the blank or null vault name to each volume that should be stored at the main tape library location. See the CA-1 documentation for information on how the VMS assigns other VMS-defined vault names.

LCM considers VMS vault names (out-of-area codes) as location codes. You can create an LCM LOCATION statement to define any VMS vault name to LCM; for more information, see [“LOCATION” on page 91](#). StorageTek recommends that you create LOCATION statements for your vaults before you create any DATASET or SUBPOOL statements to control whether vaulted cartridges are ejected based on location, regardless of whether the cartridges are covered by a DATASET or SUBPOOL statement with the METHOD parameter specified. If you code LOCATION statements for your local location codes, StorageTek recommends that you do not use the METHOD parameter so that the method can be controlled by other statements.

Note: If you need to use a volume that is scheduled for vaulting, you may need to manually check it in through CA-1.

LCM automatically creates the LOCATION statements shown in Figure 8 for local locations. You can create LOCATION statements to override the statements shown in [FIGURE 3-4](#).

```
location loccode(' ') name('Local') slots;  
location loccode(libr) name('Local') slots;  
location loccode(' LIB') name('Local') slots;  
location loccode(' VMS') name('Local') slots;
```

FIGURE 3-4 Internally Created LOCATION Statements for VMS-defined Vaults

Note – VMS-defined vault names that begin with a blank character, must be enclosed in quotes and in all uppercase letters, which VMS requires for vault names. The order in which LCM ejects cartridges is determined by the order in which the corresponding location names appear in the LCM parameter file.

You can also specify all VMS-defined vaults on a single LOCATION statement using the unique location code *CA1LOCAL as shown in [FIGURE 3-5](#).

```
location loccode(*CA1LOCAL)name('local') slots;
```

FIGURE 3-5 *CA1LOCAL location code to include all VMS-defined Vaults

[FIGURE 3-6](#) shows LOCATION statements for user-defined vault names VLT1, ARCH, and a blank for the main library, and the VMS-defined vault name VMS and a METHOD statement to manage locations VLT1 and ARCH.

```
/* VAULT method. The EJECT parameter can be changed to EJECT(NO) */  
/* if you do not want vaulted tapes to be ejected by this LCM run. */  
  
method name(vault) eject(yes);  
  
/* LOCATION statements for VLT1, ARCH, the main library, and VMS. */  
  
location code(vlt1) name(Vault1) method(vault) slots;  
location code(arch) name(Archive) method(vault) slots;  
location code(' ' VMS) name(Local) noslots;
```

FIGURE 3-6 Example of Defining CA-1 Vault Names as LCM Locations

Note – By using a METHOD statement to define method VAULT, you can control whether volumes in locations VLT1 and ARCH are ejected by simply changing the EJECT parameter value on the METHOD statement. You could also specify a method that uses the ORDER parameter so that volumes in these locations are selected for ejection or demotion first if required.

How LCM Manages Out-of-Area Codes without Corresponding LOCATION Statements

LCM treats out-of-area codes without corresponding LOCATION statements as follows:

- If the out-of-area code is one of the VMS-defined vault names, LCM uses these LOCATION statement parameter values and keywords:

- i. NAME(Local)

- ii. SLOTS

- iii. no method

- If the out-of-area code is a user-defined vault name and a default LOCATION statement exists, its parameters are used.

- If the out-of-area code is a user-defined vault name but a default LOCATION statement does not exist, LCM uses these parameters:

- i. location name the same as the out-of-area code

- ii. NOSLOTS

- iii. no method.

▼ Using LCM to Manage Vault Rotation

Vault rotation occurs when volumes are physically moved between the main tape library and vaults. The VMS vaulting schedule usually drives vault rotation. If you use LCM to manage vault rotation per the VMS vaulting schedule, use the following guidelines.

- Define all required vaults with `LOCATION` statements or use the automatically created `LOCATION` statements. Ensure these `LOCATION` statements specify methods that indicate LCM should always eject the associated nonscratch volumes for LCM jobs that support the vaulting schedule.
- Generally, run a VMS vaulting job first, then run an LCM job that ejects all volumes associated with offsite locations.

The parameter file shown in [FIGURE 3-7](#) causes LCM to eject all volumes in LSM 000 or LSM 001, which are associated with one of the user-defined vaults VLT1, VLT2, or ARCH. This parameter file also disables HSC scratch status synchronization, but does not specify any other LSM content management requirements for LCM.

```
options nosync title('Daily Vault Rotation Run');

tms ca1;

/* VAULT method. The EJECT parameter can be changed to EJECT(NO)  */
/* for LCM runs where you do not want vaulted tapes to be ejected. */

method name(vault) eject(yes);

/* LOCATION statements                                           */

location code(vlt1 vlt2) method(vault) name('Vault');
location code(arch) method(vault) name('Catacomb');
location code(*CA1LOCAL) name(Local) noslots;

manage lsmid(00:00 00:01);
```

FIGURE 3-7 Example of Defining Locations to Perform Vault Rotation

▼ Using LCM to Manage Data Sets

You can use the `DATASET` control statement to have LCM manage LSM content by data set name. For CA-1, LCM uses the data set name contained in the TMC volume record as the controlling data set name for the volume.

▼ Using LCM to Manage Externally Managed Volumes

LCM does not automatically assign a management method to externally managed volumes. You can, however, use the `EXTERNAL` parameter on the `OPTIONS` statement to specify the method LCM uses to manage these volumes. For example, [FIGURE 3-8](#) shows an `OPTIONS` statement that specifies that LCM unconditionally uses the `NEVEREJECT` method to manage externally managed volumes.

```
options external (neverreject uncond);
```

FIGURE 3-8 Example of Specifying `NEVEREJECT` for Externally Managed Volumes

If you do not specify the `UNCOND` subparameter, the method specified is a default that will be used if no other statement covers the volume and specifies a method. For example, if you want to control some externally managed volumes using the `DATASET` statement, do not specify the `UNCOND` subparameter.

Note – You can use `EXTERNAL` to assign a method to volumes controlled by `DFHSM`, but a `DATASET` statement specifying the prefix for migration and backup data sets gives you more control.

▼ Using LCM to Manage Expired Volumes

LCM marks a volume as expired if you specify the `TMS CA1 EXPIRECHECK` parameter, it is not scratch and `EXPDT` is a non-special date equal to or earlier than today's date.

▼ Using LCM to Unconditionally Eject Volumes Deleted from the CA-1 TMC

The CA-1 TMC can mark volumes “in delete status”. You can use the `TMS CA1 DELETECHECK` parameter to specify that LCM discards information for volumes marked “in delete status” in the TMS, or you can unconditionally ejects these volumes as shown in the following example:

```
tms ca1 tmcdsn(CA1TMC) NoDeleteCheck;
```

```
set method
```

```
  when (deleted) eject; // Eject all volumes marked deleted in the tms.
```

How LCM Processes Specific OPTIONS Statement Parameters For CA-1

The following sections describe how LCM processes specific OPTIONS statement parameters for CA-1.

CYCLESOON

The CYCLESOON parameter specifies that LCM does not select volumes to eject that will expire soon. TABLE 3-1 describes how LCM determines volume expiration dates, where:

nnn

any decimal number must be substituted.

Missing

LCM does not apply CYCLESOON processing to the volume.

TABLE 3-1 LCM Cycle Date for CA-1 TMC Value

CA-1 Expiration Keyword/Date	LCM Cycle Date
CATLG	Missing
CATLG/ <i>nnn</i>	Missing
CYCLE/ <i>nnn</i>	Missing
FOREIGN	Missing
LDATE/ <i>nnn</i>	Volume last reference date + <i>nnn</i>
MSG/ <i>nnn</i>	Missing
PERM	Missing
STATS/ <i>nnn</i>	Missing
USER/ <i>nnn</i>	Missing
Julian date	Julian date (unchanged)

EJBAD

The EJBAD option specifies that LCM ejects all scratch volumes marked as defective. LCM reads flag TMBADTAP in field TMFLAG3 of the TMC to determine if a volume has been marked as defective. You can also use the CLEANCHECK parameter to specify that LCM uses flag TMCLEAN in field TMFLAG1 to determine a volume's defective status.

PICKSCR

The PICKSCR option specifies that LCM selects which scratch volumes to enter when additional scratch volumes are required. These volumes are listed on the LSM Enter Report. If PICKSCR is not specified, LCM still determines the number of additional scratch volumes required. The operator can choose which scratch volumes to enter.

If PICKSCR is specified but IGNORE18TRKFLAG is not, LCM selects only non-LSM scratch volumes that are indicated in the TMS as being cartridges for entry into an LSM. LCM uses flag TM18TRK in field TMTRTCH of the TMC to determine if a volume is a cartridge.

Using LCM with DFSMSrmm

This section tells how to use LCM with DFSMSrmm as described in the following sections:

- [“Using the DFSMSrmm API to Obtain Volume Information” on page 48](#)
- [“Using LCM to Manage DFSMSrmm Scratch Subpools” on page 49](#)
- [“Using LCM with the DFSMSRMM Vital Record Specifications” on page 52](#)
- [“Using LCM to Manage Expired Volumes” on page 56](#)
- [“How LCM Processes Specific OPTIONS Statement Parameters For DFSMSrmm” on page 56](#)

Note – The EXTERNAL parameter on the OPTIONS statement does not have any meaning to LCM when using DFSMSrmm because it has no externally managed flag.

▼ Using the DFSMSrmm API to Obtain Volume Information

The API parameter of the TMS RMM statement specifies that LCM obtains information from the RMM API, not from the DFSMSrmm report extract data. For more information, see [“TMS RMM” on page 166](#).

The advantages of using the API include:

- Eliminating problems in using the extract file interface, such as old extract files with obsolete data, synchronization problems caused by the lag-time between generating the extract and the time the information is used by LCM, x37 abends, and so forth.
- The ability to generate real-time information for LCM Agent. In effect, the RMM flat-file interface is not workable for remote TMS access.

Note – The **disadvantage** of using the DFSMSrmm API is that you may experience a significant increase in execution time with the API compared to the extract file interface. The API, therefore, is not the default interface except with LCM Agent.

▼ Using LCM to Manage DFSMSrmm Scratch Subpools

LCM can manage the LSM scratch volume supply for DFSMSrmm scratch subpools. LCM can also select for entry scratch volumes that are defined to the DFSMSrmm system. For DFSMSrmm, LCM considers a volume as scratch if the RMM CDS shows the volume is scratch (report extract data set volume record field 'rvstatus' = 'SCRATCH' or API Structured Field Introducer 'VST' = '40'), and is not bad (based on the PERMERRORS and TEMPERRORS parameters).

The reference date that LCM uses for a volume in the DFSMSrmm report extract data set is the most recent of the following dates:

- Create Date
- Last Change Date
- Last Read Date
- Last Written Date

The following procedure tells how to define a DFSMSrmm scratch subpool to LCM. Also see [“Managing a Single Scratch Volume Subpool” on page 50](#) and [“Managing Multiple Scratch Volume Subpools” on page 50](#).

To define a DFSMSrmm scratch subpool to LCM:

1. Create an LCM OPTIONS statement to define global processing options for DFSMSrmm.

LCM can pick scratch volumes for entry as specified by the PICKSCR parameters of the OPTIONS statement. LCM reads DFSMSrmm information and selects scratch volumes that are not in-transit, are in the ACS (are not in a storage location), and have the lowest use counts; see [“OPTIONS” on page 114](#).

2. Create an LCM SUBPOOL statement to define a subpool that corresponds to a DFSMSrmm subpool.

The DFSMSrmm VLPOOL control statement defines the subpool to DFSMSrmm. For more information on the LCM SUBPOOL control statement, see [“SUBPOOL” on page 140](#).

Ensure that the volsers specified on the VLPOOL statement match those specified on the SUBPOOL statement. StorageTek recommends you use the same subpool name in both statements.

3. Create an LCM MANAGE statement to define the scratch criteria.

LCM can ensure that a sufficient supply of scratch volumes resides in the ACS as specified by the NUMSCR parameter of the MANAGE statement. LCM also can eject excess scratch volumes of LSM scratch subpools as specified by the CMAXSCR and AMAXSCR parameters of the MANAGE statement. LCM reads DFSMSrmm information and selects volumes with the highest volume use counts for ejection. For more information, see [“MANAGE PHYSICAL” on page 969](#).

▼ Managing a Single Scratch Volume Subpool

Caution – If your configuration does not use multiple DFSMSRmm scratch subpools, LCM can manage the entire LSM scratch volume supply as a single subpool. You can either define an LCM subpool or use the predefined GENERAL subpool.

FIGURE 3-9 shows an example of a MANAGE statement to manage the entire LSM scratch volume supply as the GENERAL subpool.

```
manage lsmid(00:00)
  /* Ensure at least this many */
  numscr.general(150)
  /* Don't remove below this limit */
  cmaxscr.general(175) ;
```

FIGURE 3-9 Example of Managing a DFSMSRmm Scratch Pool

▼ Managing Multiple Scratch Volume Subpools

FIGURE 3-10 shows DFSMSRmm VLPOOL control statements that define scratch subpools BACKUP TAPES, ADMINISTRATION, and PAYROLL.

```
VLPOOL PREFIX BK* TYPE(S) -
  DESCRIPTION('BACKUP TAPES')
VLPOOL PREFIX ADM* TYPE(S) -
  DESCRIPTION('ADMINISTRATION')
VLPOOL PREFIX PAYR* TYPE(S) -
  DESCRIPTION('PAYROLL')
);
```

FIGURE 3-10 Example of Multiple DFSMSRmm Scratch Pools

Note – If you have a volser that begins with the VLPOOL prefix but the suffix is not numeric, LCM will not manage it by subpool. For example, if the DFSMSRmm subpool prefix is BK* and the LCM subpool serial number range is BK0000-BK9999, then volume BKABCD would not be managed by LCM subpool.

FIGURE 3-11 shows LCM SUBPOOL and MANAGE statements that define the DFSMSrmm scratch subpools shown in FIGURE 3-10 on page 50.

```
subpool name('Backup Tapes')
  serials(BK0000-BK9999);
subpool name('Administration')
  serials(ADM000-ADM999);
subpool name(Payroll)
  serials(PAYR00-PAYR99);
manage lsmid(00:00)
  numfree(20)
  numscr .'Backup Tapes' ( 75 )
  cmaxscr.'Backup Tapes' ( 100 )
  numscr .'Payroll' ( 10 )
  cmaxscr.Payroll ( 50 ) ;
manage lsmid(00:01)
  numfree(125)
  numscr .'Backup Tapes' ( 75 )
  cmaxscr.'Backup Tapes' ( 100 )
  numscr .'Administration' ( 10 )
  cmaxscr.'Administration' ( 25 ) ;
```

FIGURE 3-11 Example of Defining Multiple DFSMSrmm Scratch Subpools for LCM

Note – You can define multiple scratch subpools to be managed by LCM even if your site does not use multiple DFSMSrmm scratch subpools. Multiple scratch subpools can be used, for example, to maintain LSM scratch volume supplies for different user groups or applications. These user groups or applications must follow site volser use conventions for this approach to work effectively.

Using LCM with the DFSMSRMM Vital Record Specifications

The DFSMSrmm Vital Record Specifications (VRS) set policies for retaining or moving volumes among storage locations or within the ACS. The VRS contains destination names and volume movement schedules. If the VRS in-transit flag is on, the volume is scheduled for movement and the destination is recorded in the report extract data set. If the in-transit flag is off, the volume is not to be moved and the location code that LCM records for the volume is the current store location name unless there is a value in the RVLONLOC field indicating the volume is currently on loan outside ACS or designated storage locations.

To maintain VRS integrity with LCM, follow VRS guidelines and the guidelines in “Defining VRS Store Location Names to LCM with LOCATION Statements” and “Using LCM to Manage Volume Movement” on page 55.

▼ Defining VRS Store Location Names to LCM with LOCATION Statements

LCM considers DFSMSrmm store location names or destination names as location codes. You can create an LCM LOCATION statement to define any VRS Store Location Name to LCM; for more information, see “LOCATION” on page 91. StorageTek recommends that you create LOCATION statements for your storage locations before you create any DATASET or SUBPOOL statements to control whether volumes in these locations are ejected based on location, regardless of whether the cartridges are covered by a DATASET or SUBPOOL statement with the METHOD parameter specified. If you code LOCATION statements for your local location codes, StorageTek recommends that you do not use the METHOD parameter so that the method can be controlled by other statements.

DFSMSrmm assigns the following destinations/locations:

LOCAL

Onsite or offsite storage location

DISTANT

Onsite or offsite storage location

REMOTE

Onsite or offsite storage location

SHELF

Shelf locations in a non-system-managed library

sms_defined_library_name

Shelf locations in a system-managed library

Note – Volumes scheduled for storage at a user-defined storage location are considered in-transit and you may need to confirm volume moves by building the appropriate DFSMSrmm CHANGEVOLUME subcommands.

FIGURE 3-12 shows LOCATION statements for SHELF, LOCAL, DISTANT, and REMOTE. By using a METHOD statement to define a method of STORAGE, you can control whether volumes are ejected by simply changing the METHOD statement. In this example, volumes with storage locations are always ejected.

```
/* STORAGE method. The EJECT parameter can */
/* be changed to EJECT(NO) if you do not want */
/* storage tapes to be ejected by this */
/* LCM run. */

method name(storage) eject(yes);

/* LOCATION statements for SHELF, LOCAL, */
/* DISTANT and REMOTE */

location code(Shelf);
location code(Local) method(storage) slots;
location code(Distant) method(storage) slots;
location code(Remote) method(storage) slots;
```

FIGURE 3-12 Example of DFSMSrmm Storage Locations

Note that the location code for the volume comes from one of three possible sources:

- If the in-transit flag is on, the destination is used.
- If the loan location field is not blank, the loan location is used.
- If the in-transit flag is off and the loan location is blank, the store location is used.

Also note the value that prints for slots is the bin number for all volumes in a storage location, and the rack number for all volumes in the ACS.

The order in which LCM ejects volumes is determined by the order in which the corresponding location names appear in the LCM parameter file.

How LCM Manages Location Codes without Corresponding LOCATION Statements

LCM treats location codes without corresponding LOCATION statements as follows:

- If the location code is a user-defined library name and a default LOCATION statement exists, its parameters are used.
- If the location code is a user-defined library name but no default LOCATION statement exists, LCM uses these parameters:
 - a. location name the same as the location code,
 - b. NOSLOTS, and
 - c. no method.

▼ Using LCM to Manage Volume Movement

Volume movement occurs when volumes are physically transported between the main tape library and tape volume storage locations. The VRS volume movement schedule typically drives volume movement. If you use LCM to manage volume movement, use the following guidelines.

- Define all required storage destinations/location with `LOCATION` statements or use the automatically created `LOCATION` statements. Ensure these `LOCATION` statements specify methods that indicate LCM should always eject the associated nonscratch volumes for LCM jobs that support the volume movement schedule.
- Generally, first run a `DFSMSrmm` job that schedules volumes for storage at a specific location, then run an LCM job that ejects all volumes associated with that storage location.

The parameter file shown in [FIGURE 3-13](#) causes LCM to eject all volumes in LSM 000 or LSM 001 that are associated with one of the `DFSMSrmm` storage locations `LOCAL`, `REMOTE`, or `DISTANT`. This example parameter file also disables HSC scratch status synchronization, but does not specify any other LSM content management requirements for LCM.

```
options nosync
      title('Daily Volume Movement Run');

tms rmm;

/* STORAGE method. The EJECT parameter can */
/* be changed to EJECT(NO) for LCM runs */
/* where you do not want vaulted tapes to */
/* be ejected. */

method name(storage) eject(yes);

/* LOCATION statements */

location code(Local) method(storage);
location code(Remote) method(storage);
location code(Distant) method(storage);
location code(Shelf) noslots;
manage lsmid(00:00 00:01);
```

FIGURE 3-13 Example of Volume Movement Run

Note – By using a `METHOD` statement to define method `STORAGE`, you can control whether volumes in locations `Local`, `Remote`, and `Distant` are ejected by simply changing the `EJECT` parameter value on the `METHOD` statement. You could also specify a method that uses the `ORDER` parameter so that volumes in these locations are selected for ejection or demotion first if required.

▼ Using LCM to Manage Data Sets

You can use the `DATASET` control statement to have LCM manage LSM content by data set name. For `DFSMSrmm`, LCM uses the data set name contained in the TMS volume record as the controlling data set name for the volume.

▼ Using LCM to Manage Expired Volumes

Volumes containing expired data sets are expired volumes. LCM marks a volume as expired if you specify the TMS RMM `EXPIRECHECK` parameter, the volume is non-scratch, and the `DFSMSrmm` report extract data set shows it to be pending release.

How LCM Processes Specific `OPTIONS` Statement Parameters For `DFSMSrmm`

The following sections describe how LCM processes specific `OPTIONS` statement parameters for `DFSMSrmm`.

CYCLESOON

The `CYCLESOON` parameter specifies that LCM does not select volumes to eject that will expire soon. To apply `CYCLESOON` processing, LCM uses the volume expiration date in the `RVEXPDT` field when the `RVPENDRS`, Volume Pending Release, flag is on in `DFSMSrmm`.

EJBAD

The `EJBAD` option specifies that LCM ejects all scratch volumes marked as defective. The TMS RMM statement has two parameters, `TEMPERRO` and `PERMERRORS` to tell LCM when a scratch volume is considered defective. If the number of temporary read or temporary write errors is greater than or equal to the number of errors specified for `TEMPERRO`, the volume is considered defective. Similarly, if the number of permanent read or permanent write errors is greater than or equal to the number of errors specified by `PERMERRORS`, the volume is considered defective. LCM uses the `RVTRERR`, `RVTWERR`, `RVPRERR`, and `RVPWERR` fields in `DFSMSrmm` to determine the number of errors for a volume.

PICKSCR

The `PICKSCR` option specifies that LCM selects which scratch volumes to enter when additional scratch volumes are required. These volumes are listed on the LSM Enter Report. If `PICKSCR` is not specified, LCM still determines the number of additional scratch volumes required. The operator can choose which scratch volumes to enter.

If `PICKSCR` is specified but `IGNORE18TRKFLAG` is not, LCM selects only non-LSM scratch volumes that are indicated in the TMS as being cartridges for entry into an LSM. LCM uses flag `RVMEDREC` in `DFSMSrmm` to determine if a volume is a cartridge.

Using LCM with CA-TLMS

This section tells how to use LCM with CA-TLMS as described in the following sections:

- [“Using LCM to Manage CA-TLMS Scratch Subpools” on page 58](#)
- [“Using LCM with the CA-TLMS Tape Retention System” on page 60](#)
- [“Using LCM to Manage Externally Managed Volumes” on page 63](#)
- [“How LCM Processes Specific OPTIONS Statement Parameters For CA-TLMS” on page 64](#)

▼ Using LCM to Manage CA-TLMS Scratch Subpools

LCM can manage the LSM scratch volume supply for CA-TLMS scratch subpools. LCM can also select for entry scratch volumes that are defined to the CA-TLMS system. For CA-TLMS, LCM considers a volume as scratch if the VMF shows the volume is scratch, in service, and the volume's damaged field has not been assigned one of the values identified by the TMS TLMS statement DAMAGE parameter.

The following procedure tells how to define a CA-TLMS scratch subpool to LCM. Also see [“Managing a Single Scratch Volume Subpool” on page 59](#) and [“Managing Multiple Scratch Volume Subpools” on page 59](#).

To define a CA-TLMS scratch subpool to LCM:

- 1. Create an LCM OPTIONS statement to define global processing options for CA-TLMS.**

LCM can pick scratch volumes for entry as specified by the PICKSCR parameter of the OPTIONS statement. LCM reads the CA-TLMS VMF and selects volumes for entry that have the lowest volume use counts since purchased. LCM only selects those volumes whose DENSITY flag in the VMF indicates that the volume is a cartridge. Note that if a new cartridge has been defined to CA-TLMS but has not yet been OPENed, LCM will not list it on the LSM ENTER Report. For more information, see [“REPORT ENTER” on page 288](#).

- 2. Create an LCM SUBPOOL statement to define a subpool that corresponds to a CA-TLMS subpool.**

The POOLID option defines the subpool to CA-TLMS. For more information on the LCM SUBPOOL control statement, see [“SUBPOOL” on page 140](#).

Ensure that the volsers specified on the POOLID statement match those specified on the SUBPOOL statement. StorageTek recommends you use the same subpool name in both statements.

- 3. Create an LCM MANAGE statement to define the scratch criteria.**

LCM can ensure that a sufficient supply of scratch volumes resides in the ACS as specified by the NUMSCR parameter of the MANAGE statement. LCM can also eject excess scratch volumes of LSM scratch subpools as specified by the CMAXSCR and AMAXSCR parameters of the MANAGE statement. LCM reads the CA-TLMS VMF and selects those volumes for ejection that have the highest volume use counts since purchased. For more information, see [“MANAGE PHYSICAL” on page 96](#).

▼ Managing a Single Scratch Volume Subpool

If your configuration does not use multiple CA-TLMS scratch subpools, LCM can manage the entire LSM scratch volume supply as a single subpool. You can either define an LCM subpool or use the predefined GENERAL subpool.

FIGURE 3-14 shows an example of a MANAGE statement to manage the entire LSM scratch volume supply as the GENERAL subpool.

```
manage lsmid(00:00)
  numscr.general(150) /* Ensure at least this many */
  cmaxscr.general(175) ; /* Don't remove below this limit */
```

FIGURE 3-14 Example of Managing a Single CA-TLMS Scratch Pool with LCM

▼ Managing Multiple Scratch Volume Subpools

FIGURE 3-15 shows examples of CA-TLMS POOLID option statements that define the OPER, PAY, and MKTG scratch subpools.

```
POOLID=OPER,DSN=OPER,LO1=100000,HI1=199999
POOLID=PAY,DSN=PAYROLL,LO1=705000,HI=705999
POOLID=MKTG,DSN=MKTG,LO1=450000,HI1=705999
```

FIGURE 3-15 Example of Multiple CA-TLMS POOLID Definitions

FIGURE 3-16 shows LCM SUBPOOL and MANAGE statements that define the CA-TLMS scratch subpools shown in FIGURE 3-15.

```
subpool   name(oper)   serials(100000-199999) ;
subpool   name(pay)   serials(705000-705999) ;
subpool   name(mktg)  serials(450000-705999) ;

manage lsmid(00:00)
  numfree(20)
  numscr .oper ( 75 )
  cmaxscr.oper ( 100 )
  numscr .pay ( 60 )
  cmaxscr.pay ( 100 ) ;

manage lsmid(00:01)
  numfree(125)
  numscr .oper ( 75 )
  cmaxscr.oper ( 100 )
  numscr .mktg ( 150 )
  cmaxscr.mktg ( 250 ) ;
```

FIGURE 3-16 Example of Defining Multiple CA-TLMS Scratch Subpools for LCM

Note – You can define multiple scratch subpools to be managed by LCM even if your site does not use multiple CA-TLMS scratch subpools. Multiple scratch subpools can be used, for example, to maintain LSM scratch volume supplies for different user groups or applications. These user groups or applications must follow site volser use conventions for this approach to work effectively.

▼ Using LCM with the CA-TLMS Tape Retention System

The CA-TLMS Tape Retention System (TRS) schedules volumes for movement to predefined locations. The CA-TLMS system administrator defines location definitions and a volume movement schedule for the TRS. LCM can interface with the TRS to help manage volumes in an LSM that is under TRS control.

To maintain TRS integrity with LCM, follow TRS guidelines.

▼ Defining TRS Location IDs to LCM with LOCATION Statements

When the TRS schedules a volume for storage at a specific location, it assigns the location ID (defined by the TRS SCA control statement) to the volume. The CA-TLMS system administrator codes this statement as a record of the Retention Master File (RMF).

LCM considers TRS location IDs as LCM location codes. You can create an LCM LOCATION statement to define any TRS location ID to LCM; for more information, see [“LOCATION” on page 91](#). StorageTek recommends that you create LOCATION statements for your location IDs before you create any DATASET or SUBPOOL statements to control whether volumes scheduled for movement are ejected based on location, regardless of whether the volumes are covered by a DATASET or SUBPOOL statement with the METHOD parameter specified. If you code LOCATION statements for your local location IDs, StorageTek recommends that you do not use the METHOD parameter so that the method can be controlled by other statements.

[FIGURE 3-17](#) shows TRS SCA control statements that define location IDs DC (onsite at data center), L1 (offsite library), and A1 (offsite archive). TRS assigns the default location of DATACTR to each volume stored at the main tape library location.

```
SCADCU    ... Data center: slots undefined.
SCAL1C    ... Library, slots defined: cabinet definitions follow.
C199C299C399C499 ... Cabinets with 100 slots each.
SCAA1B    ... Archive, with boxes: box definitions follow.
BOX149BOX249 ... Boxes that hold 50 volumes each.
```

FIGURE 3-17 Example of CA-TLMS TRS Location Definitions

FIGURE 3-18 shows an example of LOCATION statements to define the TRS location IDs shown in FIGURE 3-17 on page 60.

```
/* OFFSITE method. The EJECT parameter can be changed to EJECT(NO) */
/* if you do not want offsite tapes to be ejected by this LCM run. */

method name(offsite) eject(yes);

/* LOCATION statements for L1, L2, A1 and the main library. */

location code(L1 L2) name(Library) method(offsite) slots;
location code(a1) name(Archive) method(offsite) slots;
location code(dc) noslots;
```

FIGURE 3-18 Example of Defining CA-TLMS Locations as LCM Locations

Note that the default TRS location, CODE(DC), represents the main library location.

How LCM Manages Location IDs without Corresponding LOCATION Statements

LCM treats location IDs without corresponding LOCATION statements as follows:

- If a default LOCATION statement exists, its parameters are used.
- If no default LOCATION statement exists, LCM uses these parameters:
 - a. location name the same as the location ID
 - b. NOSLOTS
 - c. no method.

▼ Using LCM to Manage Volume Movement

Volume movement occurs when volumes are physically moved between the main tape library and storage locations. The RMF schedule (a set of TRS TDA commands) usually drives volume movement. If you use LCM to manage vault rotation per the RMF schedule, use the following guidelines.

- Define all required vaults with LOCATION statements. Ensure these LOCATION statements specify methods that indicate LCM should always eject the associated nonscratch volumes for LCM jobs that support the vaulting schedule.
- Generally, run an RMF job first, then run an LCM job that ejects all volumes associated with offsite locations.

The parameter file shown in [FIGURE 3-19](#) causes LCM to eject all volumes in LSM 00:00 or LSM 00:01 that are associated with one of the CA-TLMS locations L1, L2, or A1. This parameter file also disables HSC scratch status synchronization, but does not specify any other LSM content management requirements for LCM.

```
options nosync title('Daily Volume Movement Run');

tms tlms;

/* OFFSITE method. The EJECT parameter can be changed to EJECT(NO)   */
/* for LCM runs where you do not want offsite tapes to be ejected.    */

method name(offsite) eject(yes);

/* LOCATION statements                                               */

location code(l1 l2) name(Library) method(offsite);
location code(a1) name(Catacomb) method(offsite);
location code(dc) name(Local);
manage lsmgrp(Main) lsmid(00:00 00:01);
```

FIGURE 3-19 Example of Defining Locations to Perform Volume Movement

Note – By using a METHOD statement to define method *offsite*, you can control whether volumes in locations L1, L2, and A1 are ejected by simply changing the EJECT parameter value on the METHOD statement. You could also specify a method that uses the ORDER parameter so that volumes in these locations are selected for ejection or demotion first if required.

▼ Using LCM to Manage Data Sets

You can use the DATASET control statement to have LCM manage LSM content by data set name. For CA-TLMS, LCM uses the data set name contained in the TMS volume record as the controlling data set name for the volume.

▼ Using LCM to Manage Externally Managed Volumes

LCM does not automatically assign a management method to externally managed volumes. You can, however, use the `EXTERNAL` parameter on the `OPTIONS` statement to specify the method LCM uses to manage these volumes. For example, [FIGURE 3-20](#) shows an `OPTIONS` statement that specifies that LCM unconditionally uses the `NEVEREJECT` method to manage externally managed volumes.

```
options external (nevereject uncond);
```

FIGURE 3-20 Example of Specifying `NEVEREJECT` for Externally Managed Volumes

If you do not specify the `UNCOND` subparameter, the method specified is a default that will be used if no other statement covers the volume and specifies a method. For example, if you want to control some externally managed volumes using the `DATASET` statement, do not specify the `UNCOND` subparameter.

Note – You can use `EXTERNAL` to assign a method to volumes controlled by `DFHSM`, but a `DATASET` statement specifying the prefix for migration and backup data sets gives you more control.

How LCM Processes Specific OPTIONS Statement Parameters For CA-TLMS

The following sections describe how LCM processes specific OPTIONS statement parameters for CA-TLMS.

CYCLESOON

The CYCLESOON parameter specifies that LCM does not select volumes to eject that will expire soon. TABLE 3-2 describes how LCM determines volume expiration dates, where:

nnn

any decimal number must be substituted.

Missing

LCM does not apply CYCLESOON processing to the volume.

If the volume or data set keep date is greater than the expiration date, LCM uses the keep date for CYCLESOON processing.

TABLE 3-2 LCM Cycle Date for TLMS VMF Value

TLMS Expiration Keyword/Date	LCM Cycle Date
AGE/ <i>nnn</i>	Volume creation date + <i>nnn</i>
CATLG	Missing
CATLG/ <i>nnn</i>	Missing
CYCLE/ <i>nnn</i>	Missing
FOREIGN	Missing
LDATE/ <i>nnn</i>	Volume last reference date + <i>nnn</i>
MSG/ <i>nnn</i>	Missing
PERM	Missing
STATS/ <i>nnn</i>	Missing
USER/ <i>nnn</i>	Missing
ZEROS	Missing
Julian date	Julian date (unchanged)

EJBAD

The EJBAD option specifies that LCM ejects all scratch volumes marked as defective. LCM considers a volume to be defective according to the value specified for the Machine Damage Indicator, BADAMAGE in the VMF, and the DAMAGE parameter of the TMS statement.

PICKSCR

The PICKSCR option specifies that LCM selects which scratch volumes to enter when additional scratch volumes are required. These volumes are listed on the LSM Enter Report. If PICKSCR is not specified, LCM still determines the number of additional scratch volumes required. The operator can choose which scratch volumes to enter.

If PICKSCR is specified but IGNORE18TRKFLAG is not, LCM selects only non-LSM scratch volumes that are indicated in the TMS as being cartridges for entry into an LSM. LCM uses flag BADEN in the VMF to determine if a volume is a cartridge.

EXPIRECHECK

CA-TLMS does not mark volumes as expired, so the EXPIRECHECK option has no effect on LCM processing for CA-TLMS volumes.

Using LCM with Control-T

The Control-T (Control-M®/Tape) TMS was previously supported through the TMS Custom interface using the CTTXLM module provided by Control-T.

LCM now supports Control-T as described in [“Required Software Maintenance Levels for Control-T Support” on page 66](#) and [“TMS CTT” on page 155](#). Also note that LCM has added “raw” fields from the Control-T media database for use as selection and output criteria (see *LCM Quick Reference* for more information on these fields).

Although specified differently via the TMS CTT statement, operation generally follows the techniques described in [“Using LCM with a Custom TMS Interface Module” on page 67](#).

Required Software Maintenance Levels for Control-T Support

- LCM: Version 6.0.0 with PTF L1L00DO (support is integrated into LCM 7.0 and above)
- Control-T: Version 7.0.00 with APAR WT0849 or above

JCL Changes for LCM Jobs

1. **Add the Control-T IOA library to the STEPLIB of the LCM job.**
2. **Add the following DD statement to the LCM job:**

```
//DAPARM DD DISP=SHR,DSN=&ILPREFA.PARM
//      DD DISP=SHR,DSN=&ILPREFA.IOAENV
```

&ILPREFA should be replaced according to the IOA installation.
3. **Define the Control-T Media database media file, first extent only (MDBD), using either the DDNAME or DSN parameter on the TMS CTT statement.**

Example of a DD statement used with the DDNAME parameter follows:

```
//LCMTMSDB DD DISP=SHR,DSN=&DBPREFT.MDBD.E000
```

&DBPREFT should be replaced according to the IOA installation.

Using LCM with a Custom TMS Interface Module

If you have a TMS that is not one of the supported types (such as CA1) on the TMS statement, you or your TMS vendor can use the LCM TMS CUSTOM interface to create an interface module to extract information from your TMS as described in the following sections:

- [“Creating and Implementing a TMS CUSTOM Interface Module” on page 67](#)
- [“Testing a TMS CUSTOM Interface Module” on page 71](#)

You specify the module name on the MODNAME parameter of the TMS CUSTOM statement; for more information, see [“TMS CUSTOM” on page 158](#).

For more information about existing vendor-provided support for the LCM TMS CUSTOM interface, see [“TMSs Supported through the Custom Interface” on page 72](#).

▼ Creating and Implementing a TMS CUSTOM Interface Module

A TMS CUSTOM interface module extracts volume information from your TMS and passes that information to LCM via the LCMSTMCI subroutine. SAMPLIB member LCMUX01S is a sample TMS CUSTOM interface module.

You specify the module name on the MODNAME parameter of the TMS CUSTOM statement; for more information, see [“TMS CUSTOM” on page 158](#). The library containing the TMS CUSTOM interface module must be included in the LCM batch job JOBLIB or STEPLIB library concatenation or in a linklist or LPA library. LCM issues message LCM0102E and terminates with condition code 8 if LCM cannot find the interface module.

▼ Creating an LCMSTMCI Subroutine

A TMS CUSTOM interface module extracts volume information by making a subroutine call to LCMSTMCI for each volume. A TMS CUSTOM interface module can extract volume information in any order, because LCM sorts volume information after receiving all volume information. A TMS CUSTOM interface module must call LCMSTMCI in AMODE(31). For more information about the linkage conventions and execution environment when a TMS CUSTOM interface module calls LCMSTMCI, see:

- [“TMS CUSTOM Interface Module Entry Conditions” on page 69](#)
- [“TMS CUSTOM Interface Module Linkage Conventions” on page 69](#)
- [“TMS CUSTOM Interface Module Parameters” on page 70](#)

LMSTMCI requires a TMCI record as its only parameter; for more information, see [“TMCI Record” on page 402](#). In general, you should create TMCI records for most volumes defined to the TMS, including non-LSM scratch volumes and volumes for multi-volume data sets. Specifically, if LCM manages a volume that is defined to the TMS, you should create a TMCI record for the volume, otherwise the volume is classified as an HSC-only volume and is not managed as you expect.

You should not, however, create TMCI records for volumes such as the following:

- Volumes that are defined to the TMS but do not physically exist (marked deleted).
- Volumes that will never reside in any LSM (reel tapes, for example).

When LCMSTMCI returns to the TMS CUSTOM interface module, general register 15 contains a return code described in [TABLE 3-3](#).

TABLE 3-3 LCMSTMCI Return Codes

Return Code	Description
0	LCM successfully stored information from the TMCI record.
4	At least one field in the TMCI record contained missing or invalid data. LCM issues a message describing the error, and stores all valid information.
8	A terminating error occurred and the TMS CUSTOM interface module should release all acquired resources and return to LCM, which has already issued an error message.
16	An MVS STOP command was issued. The TMS CUSTOM interface module should release all acquired resources and immediately return to LCM, which ignores the return code and immediately terminates.

▼ Creating an LCMITMSG Subroutine

You can create an LCMITMSG subroutine to let a TMS CUSTOM interface module write messages to the standard LCM message file. When LCMITMSG is invoked, LCM issues message LCM0700I with the message text provided by LCMITMSG. If the parameter list passed to the TMS CUSTOM interface module contains errors, the address of the LCMITMSG subroutine may not be available. In these cases, the TMS CUSTOM interface module can issue a WTO to route a message to the LCM joblog and or to the system console.

The TMS CUSTOM interface module calls LCMITMSG with a standard parameter list containing addresses of the following:

- A signed fullword that is the length of the text (maximum of 100 characters).
- The text itself.

[TABLE 3-4](#) describes LCMITMSG return codes.

TABLE 3-4 LCMITMSG Return Codes

RC	Description
0	The message was successfully issued.
4	The message text was truncated.
8	A terminating error occurred and the TMS CUSTOM interface module should release all acquired resources and return to LCM, which has already issued an error message.
16	An MVS STOP command was issued. The TMS CUSTOM interface module should release all acquired resources and immediately return to LCM, which ignores the return code and immediately terminates.

TMS CUSTOM Interface Module Entry Conditions

The following list describes the entry conditions for an LCM custom interface module:

- LCM invokes the module using problem program state and key, which is the same state and key as LCM main task LCMMAIN. The module can temporarily switch to supervisor state (and/or key zero) if necessary for a short duration.
- If the module requires APF authorization, it should first invoke the MVS TESTAUTH function to determine if it is running APF authorized and respond accordingly.
- LCM operates primarily in AMODE(31) and also invokes interface modules in AMODE(31). If an interface module requires AMODE(24), it must perform the addressing mode switch internally. Also, if an interface module uses conventional data management routines such as QSAM or BSAM, or otherwise requires residency below the 16-megabyte line, it should be link-edited with RMODE(24).
- LCM establishes an ESTAE exit during initialization. This exit remains active throughout LCM's execution and is active when LCM invokes an interface. An interface module can establish its own ESTAE exit if required, but should not cancel or bypass the LCM ESTAE exit. If an interface module abends, LCM's ESTAE exit must be permitted to receive control (directly or via cascading of ESTAE control) to allow LCM to perform any required post-abend processing.
- LCM only makes one call to an interface module for a specific TMS CUSTOM statement. The interface module, therefore, does not have to be reentrant, refreshable, or serially reusable. If multiple TMS CUSTOM statements use the same module, LCM reloads the module before each invocation.
- Before returning to LCM, an interface module must release all acquired resources and return the execution environment to its original state.

TMS CUSTOM Interface Module Linkage Conventions

LCM invokes the interface module for a specific TMS CUSTOM statement only once, passing several parameters to it using standard MVS linkage conventions. When LCM invokes an interface module, general purpose registers 1, 13, 14, and 15 contain the following values, all of which are 31-bit addresses:

- Register 1 contains the address of a variable-length parameter list.
- Register 13 contains the address of a standard 72-byte register save area aligned on a fullword boundary.
- Register 14 contains the address to which control should be returned when the interface module completes execution.
- Register 15 contains the entry point address of the interface module itself.

The parameter list pointed to by general register 1 on entry to a custom interface module is a sequence of fullword (31-bit) addresses aligned on fullword boundaries. All addresses except the last address in the list contain a 0 in their high-order bit. The last address contains a 1 in its high-order bit. Each address in the list points to the corresponding parameter that is passed to the interface module.

These parameters can reside above the 16MB line, and instructions addressing them should execute in AMODE(31). In all cases, the value of a parameter list address should be compared to zero before its use: a value of zero in the parameter list (not counting the high-order bit) indicates that the corresponding parameter has not been supplied. For more information about these parameters, see ["TMS CUSTOM Interface Module Parameters" on page 70](#).

The content of general register 0 and general registers 2 through 12 are unpredictable. If LCM is running under the MVS/ESA operating system, all address space registers contain the ALET of the home address space.

TMS CUSTOM Interface Module Return Conditions

On completion, the interface module must set a return code in general register 15 as described in [TABLE 3-5](#).

TABLE 3-5 Interface Module Return Codes

RC	Description
0	All operations completed successfully; LCM processing continues.
4	A non-terminating error occurred; LCM issues message LCM0100W and continues processing. When LCM execution completes, the final condition code is at least 4 (higher if more severe errors are also encountered).
8	A terminating error occurred; LCM issues message LCM101E and terminates immediately with a condition code of 8.

On return to LCM, all general registers (with the exception of general register 15) and all address space registers (under MVS/ESA) must contain the values they had upon entry to the TMS CUSTOM interface module.

TMS CUSTOM Interface Module Parameters

[TABLE 3-6](#) describes the required parameters for a TMS CUSTOM interface module.

TABLE 3-6 TMS CUSTOM Parameters

Parameter	Description
version	A twenty (20) character field containing the current version, release, and modification level of LCM.
lcmstmci_epa	The entry point address of subroutine LCMSTMCI; for more information, see “Creating an LCMSTMCI Subroutine” on page 75.
lcmitsmsg_epa	The entry point address of subroutine LCMITMSG; for more information, see “Creating an LCMITMSG Subroutine” on page 76.
ddname	An eight character field, capitalized and padded to the right with blanks, which is the ddname specified on the DDNAME parameter of the TMS CUSTOM statement; for more information, see “TMS CUSTOM” on page 173. If this parameter is all blanks or if the corresponding address in the parameter list is binary zeros, no value was specified for DDNAME (the DSNAME parameter was specified instead)
tmsname	A ten character field, capitalized and padded to the right with blanks, which is the TMS name specified on the NAME parameter of the TMS CUSTOM statement; for more information, see “TMS CUSTOM” on page 173. If this parameter is all blanks, or if the corresponding address in the parameter list is binary zeros, no value was specified for NAME.

TABLE 3-6 TMS CUSTOM Parameters

Parameter	Description
tmsparm	A variable-length string (from zero to fifty characters in length), which is the text string specified by the PARM parameter of the TMS CUSTOM statement. The value of <i>text</i> is preceded by a signed halfword value equal to the length of the specified text (not including the two-byte length value). If the length prefix is equal to zero or if the corresponding address in the parameter list is binary zeros, no value was specified for PARM .
modname	An eight character field, capitalized and padded to the right with blanks, which is the name of the TMS CUSTOM interface module specified by the MODNAME parameter of the TMS CUSTOM statement. If this parameter is all blanks or if the corresponding address in the parameter list is binary zeros, no value was specified for MODNAME .
EFACOUNT	A halfword integer that indicates the number of extended fields supported by LCM. It determines the size of the table pointed to by EFAREF .
EFAREF	A table of one-byte entries that indicates which extended fields have been referenced in the parameter file. Each extended field has a key value, which is used as an offset into this table. If the corresponding byte is 'Y', the field has been referenced in the parameter file and should be passed back to LCM in the TMCIs for volume records.

The LCMUX01P DSECT provided in the LCM SAMPLIB maps the parameter list described in [TABLE 3-6 on page 70](#).

All fields in this DSECT are 31-bit addresses that point to the corresponding parameter. Parameters pointed to by these addresses can reside above the 16MB line. The first address in the parameter list containing a 1 in its high-order bit position is the final parameter of the list. Any attempt to access storage beyond the final parameter list address may cause a storage protection violation.

▼ Testing a TMS CUSTOM Interface Module

To test a TMS CUSTOM interface module, StorageTek recommends that you:

- Run LCM in CHECK mode. For more information, see “OPTIONS” on page 126.
- Create a **DEBUG WRITETMCI** statement in the LCM parameter file to validate the information passed to the TMS CUSTOM interface module as shown below:

```
DEBUG WRITETMCI;
```

This statement causes LCM to write a copy of each TMCI record it receives to ddname **LCMTMCI** before performing any other operation. You must include ddname **LCMTMCI** in the LCM JCL when you create a **DEBUG WRITETMCI** statement. The data set identified by ddname **LCMTMCI** must have sufficient space for all TMCI records passed to LCM from the **TMS CUSTOM** statement. The data set can have fixed or varying length records, providing that the record length can accommodate any TMCI record. The default data set attributes for the **LCMTMCI** data set are as follows:

- Sequential data set organization (**DSORG=PS**).
- Varying length blocked records (**RECFM=VB**).
- Logical record length of **TMCI_MAXIMUM_L+4** (**LRECL=4100**).
- The block size depends on the type of DASD device used for the data set.

See the following sample LCMTMCI DD statement:

```
//LCMTMCI DD DISP=(NEW,CATLG),
//      DSN=TMCI.DATA.SET,
//      DCB=(RECFM=VB,LRECL=255,BLKSIZE=6160),
//      SPACE=(CYL,(100,100),RLSE),
//      UNIT=SYSALLDA
```

After you verify the operation of a TMS CUSTOM interface module, remove the DEBUG WRITETMCI statement and accompanying LCMTMCI DD statement from the LCM job.

TMSs Supported through the Custom Interface

[TABLE 3-7](#) describes vendor-supplied support for TMSs through the Custom Interface. You must obtain the module listed in the third column from your software vendor. For more information on the statement parameters, see [“TMS CUSTOM” on page 158](#).

TABLE 3-7 TMSs Support through the Custom Interface

TMS	Vendor	TMS CUSTOM MODNAME Value	TMS CUSTOM PARM Value
Automedia for MVS	Allen Systems Group	ZARALCMX	'SUBSYS=ZARA'
Control-T	BMC Software, Inc	CTTXLM	n/a

Using LCM with Open Systems Clients

The TMS OPEN interface allows the LCM Content Manager to access and process tape metadata for platforms that don't conform to MVS, OS/390, or z/OS specific standards. The TMS OPEN interface is defined by XML request and response documents. These documents provide information to the LCM Content Manager concerning the tape metadata you wish to process. When a TMS OPEN statement is invoked during an LCM run, the LCM Content Manager does the following:

1. Sends a request to the remote host for an interface definition response. The request is in the form of a TMS Interface Definition Request document formatted to XML 1.0 specifications. The request document contains information from the TMS OPEN statement that the remote host can process. The expected response from the remote host is an XML formatted document that contains information regarding how the tape metadata will be presented. This document is called the TMS Interface Definition Response document.

For more information, see:

- [“TMS Interface Definition Request Document” on page 74](#)
- [“TMS Interface Definition Response Document” on page 76](#)

2. When the LCM Content Manager is ready to retrieve tape metadata for the TMS OPEN interface, the Content Manager sends a request to the remote host for a tape information response. The request is in the form of a TMS Tape Information Request document formatted to XML 1.0 specifications. The request document indicates which volume fields LCM can use and provides information from the TMS OPEN statement. The expected response from the remote host is an XML formatted document that contains metadata for tape volumes. This document is called the TMS Tape Information Response document.

For more information, see:

- [“TMS Tape Information Request Document” on page 78](#)
- [“TMS Tape Information Response Document” on page 80](#)

All request documents sent to the remote host are UTF-8 encoded. All response documents sent from the remote host must also be UTF-8 encoded. The XML parser within LCM supports all UTF-8 encoded documents. However, the response documents are translated to EBCDIC during parsing and the EBCDIC character set does not support any UTF-8 encoded character above 0x7F. If LCM Content Manager encounters any UTF-8 encoded character above 0x7F it will replace that character with 0x4B.

Within the LCM SAMPLIB dataset are three members that will allow you to perform an example run of the TMS OPEN statement when used in conjunction with each other. They are as follows:

- LCMTTIR – This is a TMS Tape Information Response document that contains sample tape metadata that can be sent from a remote host to the LCM Content Manager. The SAMPLIB member LCMTIDR defines how the tape metadata is organized within this document.
- LCMTIDR – This is a TMS Interface Definition Response document. This document can be sent from a remote host in order to define the sample tape metadata that is contained within the SAMPLIB member LCMTTIR.

- LCMCGI – This is a sample CGI script that can be used with any HTTP server that supports the CGI specification (go to www.w3c.org for more information concerning CGI). This script was written in C. The code is well documented and explains how to retrieve and process LCM request documents.

TMS Interface Definition Request Document

To issue the request for a TMS OPEN interface definition, LCM builds a request document and attempts to contact the specified host using the POST method. The request document provides information about the version and release of LCM and information from TMS statement parameters.

For example, if LCM is processing the following TMS statement from its parameter file:

```
tms open name(MyTms)
agent(http://mytms.mydomain:3002/tms/mytms/LCM.cgi)
parm('c:tms\mytms\dbname select(all)debug');
```

Then LCM builds the following request document:

```
<?xml version="1.0"?>
<tmsinterfacedefinitionrequest>
  <accesscodes>
    <accesscode>
tmsaccess D2=s5k92$32Q195583a-58$2lbs0C8 MVShost.net
    </accesscode>
    <accesscode>
tmsaccess D2=s5k92$32Q195583a-58$2lbs0C8 authp390
    </accesscode>
    <accesscode>
tmsaccess D2=s5k92$32Q195583a-58$2lbs0C8 pats.httpmts.com
    </accesscode>
  </accesscodes>
  <version>LCM 7.2.0</version>
  <name>MyTMS</name>
  <parm>c:tms\mytms\dbname select(all) debug</parm> </tmsinterfacedefinitionrequest>
```

LCM then POSTs the request to the IP address or host name, port, and URI identified by the AGENT parameter of the TMS OPEN statement:

```
"POST /tms/mytms/LCM.cgi HTTP/1.1"
```

The remote host validates the TMS parameters from the request document and then returns a response document as described in [“TMS Interface Definition Response Document” on page 76](#).

Element Tag Descriptions

accesscodes

Contains a list of accesscode element tags that correspond to each access code defined within the LCMSECUR file. These codes can be used to validate a client's access rights to the remote host. See "Installing and Configuring LCM Agent" in *LCM Installation and Maintenance Guide* in order to see how these access codes are used by LCM. Utilizing these codes is completely optional.

accesscode

Contains a single access code that can be used to validate a client's access privileges to the remote host.

version

Contains the current version, release, and modification level of LCM.

name

The value specified for the NAME parameter of the TMS OPEN statement. In a multi-TMS environment, this character string can be used in messages to help identify which tape management system is being processed.

parm

The text specified on the PARM parameter of the TMS statement. This parameter provides a way for LCM customers to specify information on the TMS OPEN statement for use by an implementation-dependent TMS interface. The designer of the interface assigns meaning to this text. LCM does not assign any meaning to the value of this text.

Note – Additional tags may be supplied in the future. It is recommended that implementers write code that ignores any tags it does not understand.

TMS Interface Definition Response Document

The response is sent back to LCM as an XML document that contains record types, messages as needed, and a return code. The returned document must conform to the `TmsInterfaceDefinitionResponse.dtd` as described in [“TMS OPEN Document Type Definitions \(DTDs\)”](#) on page 84.

A `tmsinterfacedefinitionresponse` root element tag can contain one or more record type element tags, and zero or more message element tags. The TMS Interface Definition Response document must include at least one record type element tag. The final element tag (immediately before the end root element) in the response document must be a `returncode` element tag: a value of 0 indicates success, 4 indicates that LCM continues processing normally but ends with a warning code, and anything greater than 4 indicates that LCM terminates immediately with an error condition.

The following shows a sample response document:

```
<?xml version="1.0"?>
<tmsinterfacedefinitionresponse>
  <recordtypes>
    <record type = "base">
      <selectedfields>
        <selectfield>userTime1</selectfield>
        <selectfield>Scratch</selectfield>
        <selectfield>DatasetName</selectfield>
        [... other fields as desired ...]
      </selectedfields>
    </record>
    <record type = "secondary">
      <selectedfields>
        <selectfield>Scratch</selectfield>
        <selectfield>CreationDate</selectfield>
        <selectfield>CreationTime</selectfield>
        <selectfield>LocName</selectfield>
        <selectfield>DatasetName</selectfield>
        <selectfield>UserChar2</selectfield>
      </selectedfields>
    </recordtypes>
  <!_*****
  *Dynamic field definition ***** -->
  <fielddefinitions>
    <field name="BackupPool"          <datatype>char</datatype>
    <aliases>
      <alias>BPool</alias>
    </aliases>
    <xmldatainputsize>4</xmldatainputsize>
  </field>
  </fielddefinitions>
  <message>TMS0002I TMS Interface Processed Successfully</message>
  <returncode>0</returncode>
</tmsinterfacedefinitionresponse>
```

Element Tag Descriptions

recordtypes

Contains a list of record element tags that define how the tape metadata will be presented.

record

Defines a specific type of tape metadata and describes how it is organized.

selectedfields

Contains a list of selectfield element tags that describe what fields are included within a specific type of tape metadata, and also the order in which the fields are given. The order of each field is determined based on the order of each selectfield element tag. For example, in the example below there are three selectfield element tags for the record type *base*:

```
<record type = "base">
<selectedfields>
  <selectfield>userTime1</selectfield>
  <selectfield>Scratch</selectfield>
  <selectfield>DatasetName</selectfield>
</selectedfields>
</record>
```

Based on this record type, it is assumed that when the tape metadata of this record type is sent to LCM, the first field value within the metadata will be of field type UserTime1, the second field value will be of field type Scratch, and the third field value will be of field type Datasetname.

selectfield

Contains a single fieldname that represents a field value for which the tape metadata of the same record type contains. For a list of all fields that are allowed when using the TMS OPEN statement, please refer to the *LCM Quick Reference Field Tables* documentation. Please note that it is not necessary to include the Serial field as one of the fields referenced. This is because it is a required element attribute of the volume element tag in the TMS Tape Information Response document and therefore implies that the Serial field is a mandatory field.

fielddefinitions

Contains dynamic field definition element tags. For more information, see ["Dynamically Added Volume Fields" on page 83](#).

message

Contains a text message that will be sent to LCM. This message will be displayed in the LCMMSGSGS file within each LCM run that uses the TMS OPEN interface. The message text will be prepended with LCM message id **LCM0700I**.

returncode

Contains a return code that will be sent to LCM. The return code can be in the range of 0 – 1000. If the return code specified is greater than 0 but less than or equal to 4, LCM will issue the message ID LCM0116W. This message will contain the TMS name and return code that was specified. If the return code is greater than 4, LCM will issue the message ID LCM0117E and will terminate immediately with a return code of 8. The return code element tag is required at the end of every response document

but multiple return codes can be specified. If more than one return code element tag is specified, LCM will only process the largest one. At least one message element should be included if the return code is non-zero.

TMS Tape Information Request Document

When the LCM Content Manager is ready to retrieve tape metadata for a TMS OPEN interface, the LCM Content Manager builds and sends to the remote host a TMS Tape Information Request document that contains information from the TMS OPEN statement, a list of referenced fields, and a list of volume serials for which information is being requested. An example of a TMS Tape Information Request document is as follows:

```
<?xml version="1.0"?>
  <tmstapeinformationrequest>
    <version>LCM 7.2.0</version>
    <name>MyTMS</name>
    <parm>c:\tms\mytms\ibase select(all) debug</parm>
    <fieldsreferenced>
      <field>Scratch</field>
      [... other fields to be requested ...]
    </fieldsreferenced>
    <serials>
      <serial>*</serial>
    </serials>
  </tmstapeinformationrequest>
```

LCM POSTs this request document to the IP address or host name, port and URI indicated by the AGENT parameter of the TMS OPEN statement:

```
"POST /tms/mytms/LCM.cgi HTTP/1.1"
```

Element Tag Descriptions

version

Contains the current version, release, and modification level of LCM.

name

The value specified for the NAME parameter of the TMS OPEN statement. In a multi-TMS environment, this character string can be used in messages to help identify which tape management system is being processed.

parm

The text specified on the PARM parameter of the TMS statement. This parameter provides a way for LCM customers to specify information on the TMS OPEN statement for use by an implementation-dependent TMS interface. The designer of the interface assigns meaning to this text. LCM does not assign any meaning to the value of this text.

fieldsreferenced

A list of volume fields for which LCM is requesting information. The field names are the same volume fields listed in the LCM Quick Reference Field Tables, plus any additional fields that were referenced in the LCM run. This list can be used to avoid sending back information that is not needed.

field

Contains an individual field that is being requested within a fieldsreferenced element tag.

serials

Identifies volume serial(s) for which information is being requested.

serial

A volume serial can be specified as an individual volume serial number, as a generic reference using asterisks and question marks as wildcards, or as a range with high and low volume serial numbers separated by a dash. The reference can be specified as an include or as an exclude. The syntax for a serial tag is:

```
<serial ref=[include|exclude]>serial-specification</serial>
```

Examples of valid serial values include:

```
<serial>*</serial> <!--include all volumes in the response-->
```

```
<serial>SYS?BK</serial> <!--include serials that match this pattern-->
```

```
<serial>H*</serial> <!--include all volumes beginning with H -->
```

```
<serial>H05000-H00999</serial> <!--include volumes in this range -->
```

```
<serial ref=exclude>CLN*</serial> <!--include all but CLN carts -->
```

Additional tags may be supplied in the future. It is recommended that implementers write code that ignores any tags it does not understand.

TMS Tape Information Response Document

The remote host responds to a TMS Tape Information Request document with a document that contains volume elements, one or more message elements, and a return code element. Volume information is returned using volume element tags, where the character data of each volume element is a comma-separated list of field values in the same order defined by the record element tag within the TMS Interface Definition Response document. Message elements may appear anywhere in the document. The return code element allows the host to specify status codes. At least one return code element tag must be included at the end of the response document.

The following TMS Tape information Response document assumes that the TMS Interface Definition Response document is the same as the sample given in [“TMS Interface Definition Response Document”](#) on page 76.

```
<?xml version="1.0"?>
<tmstapeinformationresponse>
  <message>Processing volume info</message>
  <volumes>
    <volume serial = "A07303" type = "base">
05:12:22 PM,N,BACKUP.LOG.SRV      <!--this is the tape metadata -->
    </volume>
    <volume serial = "T00001" type = "secondary">
N,10/25/2010,12:10,LIB,TDATA.TEST,Transfer
    </volume>
    <volume serial = "G03433" type = "base">
22:54,y,Dbase.trial.v2.ext
    </volume>
    <volume serial = "T00002" type = "secondary">
n,10/26/2010,16:17,onsite,TDATA.ACT.PR10
    </volume>
    [- additional volume elements as needed -]
  </volumes>
  <message>Volume info processed</message>
  <returncode>0</returncode>
</tmstapeinformationresponse>
```

Element Tag Descriptions

volumes

Contains a list of volume element tags that hold actual tape metadata to be processed by LCM Content Manager.

volume

A single volume element that holds a volume record. The volume record is formatted as a group of field values delimited by commas. Each field value corresponds to specific referenced field within the TMS Interface Definition Response document of the same record type.

attributes (all element attributes are mandatory)

serial

This is the specified volser of the specific volume record that is being processed. The maximum length of this field is 6 characters.

type

This attribute allows LCM to match the tape metadata with a defined record type. This attribute corresponds to the record element tag of the same type in the TMS Interface Definition Response document.

message

Contains a text message that will be sent to LCM. This message will be displayed in the LCMMSG file within each LCM run that uses the TMS OPEN interface. The message text will be prepended with LCM message id LCM0700I.

returncode

Contains a return code that will be sent to LCM. The return code can be in the range of 0 – 1000. If the return code specified is greater than 0 but less than or equal to 4, LCM will issue the message ID LCM0116W. This message will contain the TMS name and return code that was specified. If the return code is greater than 4, LCM will issue the message ID LCM0117E and will terminate immediately with a return code of 8. The return code element tag is required at the end of every response document but multiple return codes can be specified. If more than one return code element tag is specified, LCM will only process the largest one. At least one message element should be included if the return code is non-zero.

Information regarding tape metadata within a volume element tag:

Boolean values must be coded as a single character. 'Y' or 'y' represents a true value and 'N' or 'n' represents the false value. If any other single character value is coded, a false value is assumed.

All date fields can be coded in the formats listed in the table below. Note: special date formats should be coded as described in the "TMCI_EXPIREDATE special Formats" part of this manual.

Date Type	Format	Example
Gregorian	MM/DD/YYYY	12/25/2010
Julian	YYYYDDD	2010359
Juliand	YYYY.DDD	2010.359
Normal	DD MMM YYYY	25 DEC 2010
Sgregorian	MM/DD/YY	12/25/02
Sjulian	YYDDD	02359
Sjuliand	YY.DDD	02.359
Snormal	DD MMM YY	25 DEC 02
Sortdate	YYYY-MM-DD	2010-12-25
Ssortdate	YY-MM-DD	02-12-25
SASdate7	DDMMMYY	25DEC02
SASdate9	DDMMMYYYY	25DEC2010

All time fields can use any format specified in the table below. Please note that the CreationTime field (which is part of the base TMCI) must be specified with the format type HHMM.

Time Type	Format	Example
Civilian	HH:MM:SS AM/PM	01:43:23 PM
HHMM	HH:MM	13:43
HHMMSS	HH:MM:SS	13:43:23
HHMSSTH	HH:MM:SS.TH	13:43:23.12

Any fields that are blank at the end of a single volume record do not have to be separated with commas. These fields will by default take blank values.

Dynamically Added Volume Fields

For those situations where there isn't any LCM predefined field that accurately corresponds to a volume field within the open systems TMS, it is possible to dynamically define a field to be used by LCM. These fields are defined within the TMS Interface Definition Response Document. To see a description of all the XML element tags used to create a dynamic volume field, please refer to the table in appendix E. Also, please refer to the TMS Interface Definition Response Document DTD to see the allowed structure of the dynamic volume field element tags. For more information, see ["TMS Interface Definition Response DTD" on page 84](#).

When a TMS OPEN Agent adds new volume fields, those fields can be accessed in the parameter file by specifying *tmsname.fieldname*. For example, the following parameter file syntax would be valid:

```
tms open name(SystemX) agent(http://mytms.mydomain/tms.cgi);
report volume
    when(SystemX.Application = 'MMIS/ProdCtl/ChgMan')
    column(serial, ReferenceTmsDate, SystemX.owner, SystemX.Description);
```

Given such a parameter file, LCM would communicate with the specified Agent and then use the list of fields added by SystemX to validate volume field references in other statements.

ACTION statements, SET METHOD statements, and REPORT VOLUME statements can all use dynamically added volume fields.

Because the dynamically added fields rely on information from the TMS OPEN host, it is required that the TMS OPEN statement be defined and processed before any dynamically added volume fields are specified within the parameter file.

TMS OPEN Document Type Definitions (DTDs)

The following DTDs are used to validate the TMS Interface Definition Response and the TMS Tape Information Response XML documents that are sent by the TMS host specified in the TMS OPEN statement.

TMS Interface Definition Response DTD

```
<!ELEMENT tmsinterfacedefinitionresponse
  fielddefinitions? , ( message* | recordtypes | returncode+ )* >          <!ELEMENT
message ( #PCDATA ) >
<!ELEMENT returncode ( #PCDATA ) >
<!ELEMENT recordtypes ( record+ ) >
<!ELEMENT record ( selectedfields ) >
<!ELEMENT selectedfields ( selectfield+ ) >
<!ELEMENT selectfield ( #PCDATA ) >
<!ELEMENT fielddefinitions ( field+ ) >
<!ELEMENT field ( aliases | collate | datatype | defaultoutputsize | defaultsummarytype |
description | headings | possiblevalues | xmlinputsize )* >
<!ATTLIST field name CDATA #REQUIRED >
<!ELEMENT aliases ( alias+ ) >
<!ELEMENT collate ( #PCDATA ) >
<!ELEMENT datatype ( #PCDATA ) >
<!ELEMENT defaultoutputsize ( #PCDATA ) >
<!ELEMENT defaultsummarytype ( #PCDATA ) >
<!ELEMENT description ( #PCDATA ) >
<!ELEMENT headings ( h+ ) >
<!ELEMENT h ( #PCDATA ) >
<!ELEMENT possiblevalues ( pd | pv )* >
<!ELEMENT pd ( #PCDATA ) >
<!ELEMENT pv ( #PCDATA ) >
```

TMS Tape Information Response DTD

```
<!ELEMENT tmstapeinformationresponse
  (message* | volumes | returncode+ ) >
<!ELEMENT message ( #PCDATA ) >
<!ELEMENT returncode ( #PCDATA ) >          <!ELEMENT volumes (
volume* ) >          <!ELEMENT volume ( #PCDATA ) >
<!ATTLIST volume serial CDATA #REQUIRED
  type CDATA #REQUIRED >
```

LCM Management Control Statements

This chapter contains reference information for the LCM control statements used to manage Nearline and Virtual resources.

DATASET

The DATASET statement specifies a data set name, management method, and report production for nonscratch volumes associated with that data set.

Syntax

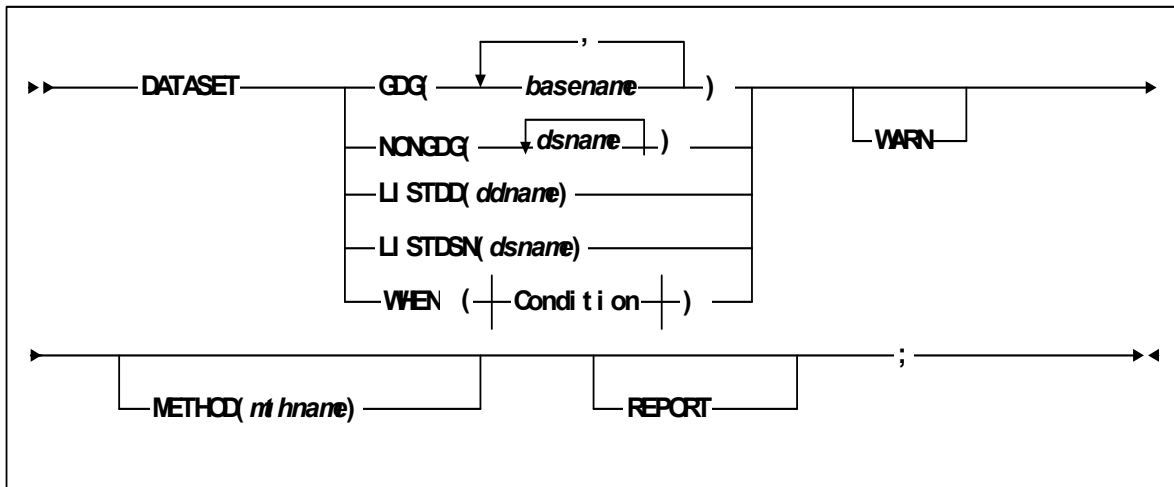

FIGURE 4-1 DATASET Statement Syntax

Parameters

TABLE 4-1 lists the valid abbreviations for the DATASET statement.

TABLE 4-1 DATASET Statement Abbreviations

Statement or Parameter	Abbreviation
DATASET	DS
METHOD	MTH
REPORT	RPT

GDG

specifies one or more tape generation data group (GDG) base names.

basename

the GDG base name.

In general, specify a base name as a data set identifier according to the following guidelines:

- Specify a base name as a generation data group base name, not as a generation data set true name. That is, do *not* specify a base name that has a suffix qualifier of the form *GnnnnVnn* where *nnnn* and *nn* are four-digit and two-digit decimal numbers, respectively.
- Do not specify a basename that consists of more than 35 characters, including periods.
- Do not specify identical base names for the GDG parameters of two or more DATASET statements in the same parameter file. You can, however, specify a base name that is identical to a dsname coded for the NONGDG parameter of another DATASET statement in the same parameter file.
- You must specify at least one base name. Separate multiple base names with one or more blanks.

NONGDG

specifies one or more nongeneration tape data set names.

dsname

the data set name.

Specify the data set name as follows.

- Do not code a *dsname* that has a suffix qualifier of the form *GnnnnVnn* where *nnnn* and *nn* are four-digit and two-digit decimal numbers, respectively, which is the suffix for a generation data set.
- Do not specify identical *dsnames* for the NONGDG parameters of two or more DATASET statements in the same parameter file. You can, however, specify a *dsname* that is identical to a basename coded for the GDG parameter of another DATASET statement in the same parameter file.
- You must specify at least one dsname. Separate multiple base names with one or more blanks.
- LCM allows the following data set name wildcards:
 - % - any single character.
 - * - any qualifier or all suffixes of a qualifier.
 - ** - any sequence of qualifiers or all data set names.

LISTDD

specifies the ddname of a file that contains a list of data set identifiers for this DATASET statement.

ddname

specifies the ddname of the JCL DD statement that is allocated to the sequential file containing the data set list.

LISTDSN

specifies the data set name of a file that contains a list of data set identifiers for this DATASET statement.

dsname

specifies the data set name of the sequential file containing the data set list.

Note – GDG, NONGDG, LISTDD, and LISTDSN are mutually exclusive parameters. You must specify one (and only one) of the GDG, NONGDG, LISTDD, or LISTDSN parameters.

A data set list is a file that contains one data set identifier per line. Each line in a data set list must have the following format:

Column	Description
1	Character "G" to indicate GDG or "N" to indicate NONGDG.
2	Blank.
3-46	The data set identifier. Refer to the descriptions for GDG and NONGDG for details on specifying the data set identifier.

WARN

specifies that LCM will issue a warning message if no data set is covered by this statement.

Note – If WARN is specified for a data set identifier that matches the controlling data set name of one or more volumes but does not cover any volumes, a warning message is still issued. This occurs if all data set names matched by the data set identifier are also matched by other, more specific data set identifiers.

METHOD

specifies the method that manages the volumes whose controlling data set is covered by this DATASET statement.

LCM uses the specified method if no previous statement in the parameter file covers the same volume and specifies a method. You can override this method with the OPTIONS statement EXTERNAL or METHODFILE options or the SET METHOD statement. This method can be influenced by the OPTIONS statement CYCLESOON, MINENTER, and MINREF options.

For more information, see:

- [“OPTIONS” on page 114](#)
- [“METHOD” on page 106](#)
- [“SET METHOD” on page 134](#)

methname

the method name.

REPORT

specifies that all data sets covered by this DATASET statement are flagged for reporting. LCM automatically produces a standard data set report for all flagged data sets unless the automatic report is suppressed with the SUPAUTORPT option on the OPTIONS statement; for more information, see [“OPTIONS” on page 114](#). You can also customize the standard data set report.

Usage

To assign management methods to nonscratch volumes based on data set name, use the METHOD parameter of the DATASET statement. If no previous statements in the parameter file assign a method to these volumes, LCM uses the specified method on the DATASET statement.

For example, to use the BACKUPS method to manage the volumes of all nonscratch generation data sets beginning with BACKUP, specify the following DATASET statement:

```
DATASET GDG(BACKUP.***) METHOD(BACKUPS) ;
```

Only one DATASET statement covers a specific nonscratch volume. If more than one *dsname* or *basename* parameter matches a specific data set name, the DATASET statement having the most specific match is used. Thus, the order in which you specify DATASET statements in a parameter file is irrelevant.

The order of DATASET statements relative to other types of statements that assign methods to volumes is important, however. LCM uses the first statement that covers a nonscratch volume and assigns it a method. If, for example, you want the location of a volume to assign a method, either specify a LOCATION statement covering a volume before the DATASET statement covering that same volume or only specify a LOCATION statement covering the volume. Note that if no statement assigns a method, LCM uses the predefined method STANDARD to manage that volume.

The order of DATASET statements relative to other types of statements that assign methods to volumes is important, however. LCM uses the first statement that covers a nonscratch volume and assigns it a method. If, for example, you want the location of a volume to assign a method, either specify a LOCATION statement covering a volume before the DATASET statement covering that same volume, or only specify a LOCATION statement covering the volume.

Note –

- If no statement assigns a method to a volume, LCM will assign a default method to the volume. The default method for Multiple Volume Cartridges (MVCs) is MVC. The default method for all other volumes is STANDARD.
- LCM provides tape data set management for *only* nonscratch volumes residing in an LSM managed by LCM and whose controlling data set name is defined to a TMS. HSC-only volumes, volumes in subpools defined with a NOTMS or IGNORE keyword, expired volumes, and volumes with a tape management scratch status of “scratch” *do not* have a controlling data set name and are not covered by DATASET statements.

LCM uses the controlling data set name to identify volumes covered by a DATASET statement. For more information on how the TMS determines the controlling data set name, see:

- [“Using LCM with CA-1” on page 38](#)
- [“Using LCM with DFSMSrmm” on page 48](#)
- [“Using LCM with CA-TLMS” on page 57](#)

Note – You can use the WARN parameter to “weed out” obsolete DATASET statements that no longer cover volumes associated with active data sets.

LOCATION

The LOCATION statement specifies a TMS volume location code, management method, and eject options for nonscratch volumes associated with that location.

Syntax

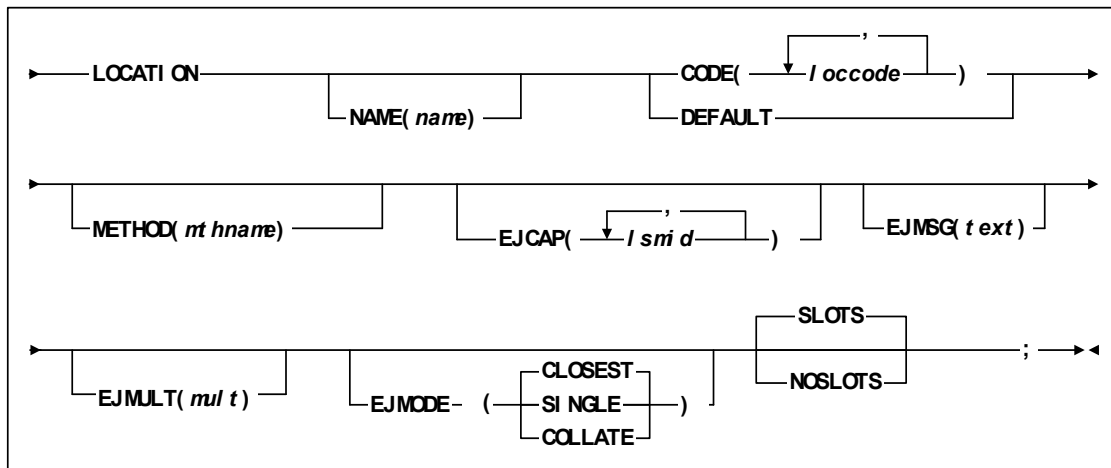

FIGURE 4-2 LOCATION Statement Syntax

Parameters

TABLE 4-2 lists the valid abbreviations for the LOCATION statement.

TABLE 4-2 LOCATION Statement Abbreviations

Statement or Parameter	Abbreviation
LOCATION	LOC
CODE	LOCCODE
NAME	LOCNAME
METHOD	MTH

NAME

defines a name for this tape storage location. This name, unlike the location code, need not be unique; you can specify same location name on multiple LOCATION statements.

The storage location name applies to all location codes covered by this LOCATION statement. If this LOCATION statement also specifies the DEFAULT keyword, the location name also applies to all location codes not covered by other LOCATION statements.

If you do not specify NAME, it defaults to the location code (CODE) unless it is the blank location code. In this case, the default value is Local. You must specify NAME if you specify multiple location codes

locname

the 1 to 10 character storage location name. The name must contain at least one nonblank character.

CODE

specifies a list of one or more tape storage location codes defined by the TMS.

Do not specify the same location code on more than one LOCATION statement or more than once on the same LOCATION statement. The CODE and DEFAULT parameters are mutually exclusive.

All unexpired nonscratch volumes in the TMS that have the specified location code or location codes and are not in volumes in subpools defined with a NOTMS or IGNORE keyword are covered by this LOCATION statement.

loccode

the location code, which is a maximum of 8 characters. Separate multiple location codes with one or more blanks.

DEFAULT

specifies that this LOCATION statement is the default for TMS location codes that do not have explicit LOCATION statements.

The CODE and DEFAULT parameters are mutually exclusive. Do not code more than one default LOCATION statement in the same parameter file.

METHOD

the method LCM uses to manage nonscratch volumes covered by this LOCATION statement. The specified method applies if no previous statement in the parameter file covers the same volume and specifies a method. This method can be overridden by the EXTERNAL and METHODFILE options of the OPTIONS statement and the

SET METHOD statement and may be influenced by the OPTIONS statement CYCLESOON, MINENTER, and MINREF options. For more information, see "OPTIONS" on page 114 and "METHOD" on page 106.

mthname

the name of the method.

EJMSG

specifies the text of the eject message (SLS1251E).

If you do not specify this parameter, LCM uses a text of 'Location' followed by the location name. For example, if the location name is Vault1, the LCM job name is LCM and the CAP is 00:00, the LCM issues the following messages issued when the CAP door is unlocked:

SLS0259A CAP PROCESSING TERMINATED; EMPTY CAPID 00:00

SLS1251E CAPID 00:00 (LCM): LOCATION VAULT1

text

the message text, which is a maximum of 32 characters. Enclose the character string in single quotes if it contains blanks or other special characters. For more information, see "[Character Data](#)" on page 17.

EJCAP

specifies a list of one or more LSMs whose CAPs are used for ejects. If this list does not contain at least one LSM for each managed ACS, LCM assumes that all LSMs in that ACS are available for use (which is also the default if you do not specify a value for EJCAP). LOCATION EJCAP overrides this setting on the OPTIONS statement.

lsmid

the hexadecimal LSM ID (00:00 to FF:7F). Note that you cannot specify individual CAPS within an LSM and LCM will not use priority CAPs. You can, however, use the LCM DISPLAY, PAUSE, RESUME, and REDIRECT commands to manage LCM activity for specific CAPs; for more information, see:

- "[DISPLAY](#)" on page 381
- "[PAUSE](#)" on page 383
- "[REDIRECT](#)" on page 385
- "[RESUME](#)" on page 386

EJMODE

specifies that LCM uses the EJCAP list as follows:

CLOSEST

eject volumes through the CAPs closest to the volume location (the default).

SINGLE

eject volumes through the CAPs of only one LSM per ACS. LCM tries to minimize pass-throughs when it selects an LSM from the EJCAP list.

COLLATE

eject volumes through the CAPs of the LSMs in the EJCAP list in ascending order. LCM ejects the lowest ordered set of volumes from the first EJCAP, the next lowest ordered set of volumes is ejected from the second EJCAP, and so forth. LCM will use as many of the LSMs in the EJCAP list as can be used at least once.

The EJMODE parameter is only valid if CAPs of multiple LSMs are included in the EJCAP list and are available. LOCATION EJMODE overrides this setting on the OPTIONS statement.

EJMULT

eject volumes in multiples specified by *mult*. For example, for EJMULT(10), LCM ejects volumes in multiples of ten, which can include situations such as ejecting forty volumes at a time through an Enhanced CAP.

Note – You can use EJMULT to force volume ejections in amounts that fit evenly into cases or magazines for transport. For example, to fill a 10-cell magazine evenly, specify EJMULT(10).

EJMULT has no effect on the selection of a CAP for eject processing. For example, specifying EJMULT(40) does not prevent LCM from selecting a 21-cell CAP for ejection.

StorageTek recommends that you do *not* specify an EJMULT value that is larger than the capacity of the smallest CAP used. For example, if you specify EJMULT(40) and a 21-cell CAP is used for ejects, LCM ejects volumes in batches of 40, which means that the operator has to empty the CAP twice (21 volumes followed by 19 volumes) for each batch of 40 volumes.

StorageTek also recommends that you do not specify large values (such as 200) for EJMULT. PAUSE commands (without the IMMED operand) do not take effect for a specific CAP until the current batch has been ejected, so large EJMULT values increase the delay before PAUSE commands take effect. There is no impact on PAUSE commands that specify the IMMED operand.

The EJMULT parameter is only valid if CAPs of multiple LSMs are included in the EJCAP list and are available. LOCATION EJMULT overrides this setting on the OPTIONS statement.

mult

the multiple that LCM uses to eject volumes. Valid values are 1 to 500 inclusive and the default is 1.

SLOTS | NOSLOTS

specifies whether LCM volumes should be ejected by TMS slot numbers (SLOTS, the default) or by volsers (NOSLOTS).

Usage

You can specify an unlimited number of `LOCATION` statements in a parameter file to specify a TMS volume location code, the management method, and eject options for nonscratch volumes associated with that location.

Only one `LOCATION` statement covers a specific nonscratch volume, so the order of `LOCATION` statements in a parameter file is irrelevant. The order of `LOCATION` statements does affect the order of ejections, however. LCM ejects volumes in the order in which the first `LOCATION` statement for each location name is coded in the parameter file.

The order of `LOCATION` statements relative to other types of statements affects method assignments. For example, if you want the location code of some volumes to determine the management method, either specify only `LOCATION` statements or specify the associated `LOCATION` statements before `DATASET` and `SUBPOOL` statements that also assign methods to those volumes. Conversely, if you do not want the `LOCATION` statement to assign a volume's management method, either do not specify `LOCATION` statements or do not specify a method on the `LOCATION` statement and do specify the method on another statement (such as `DATASET`). Note that if no statement assigns a method, LCM uses the predefined method `STANDARD` to manage that volume.

Note –

- If no statement assigns a method to a volume, LCM will assign a default method to the volume. The default method for Multiple Volume Cartridges (MVCs) is `MVC`. The default method for all other volumes is `STANDARD`.
- LCM tape location code support is provided only for unexpired nonscratch volumes that are not being ignored, reside in an LSM being managed by LCM, and whose location code is defined to the TMS. HSC-only volumes, expired volumes, and volumes with a tape management scratch status of "scratch" do not have a location code and are not covered by `LOCATION` statements. The `EJCAP`, `EJMODE`, `EJMSG`, and `EJMULT` keywords are valid only once for each location name—on the first `LOCATION` statement that uses that location name.

For more information on using `LOCATION` statement with your TMS, see:

- ["Using LCM with CA-1" on page 38](#)
- ["Using LCM with DFSMSrmm" on page 48](#)
- ["Using LCM with CA-TLMS" on page 57](#)

MANAGE PHYSICAL

The MANAGE PHYSICAL statement specifies an LSM group and management policies for the volumes and free cells in the LSMs in the group.

Syntax

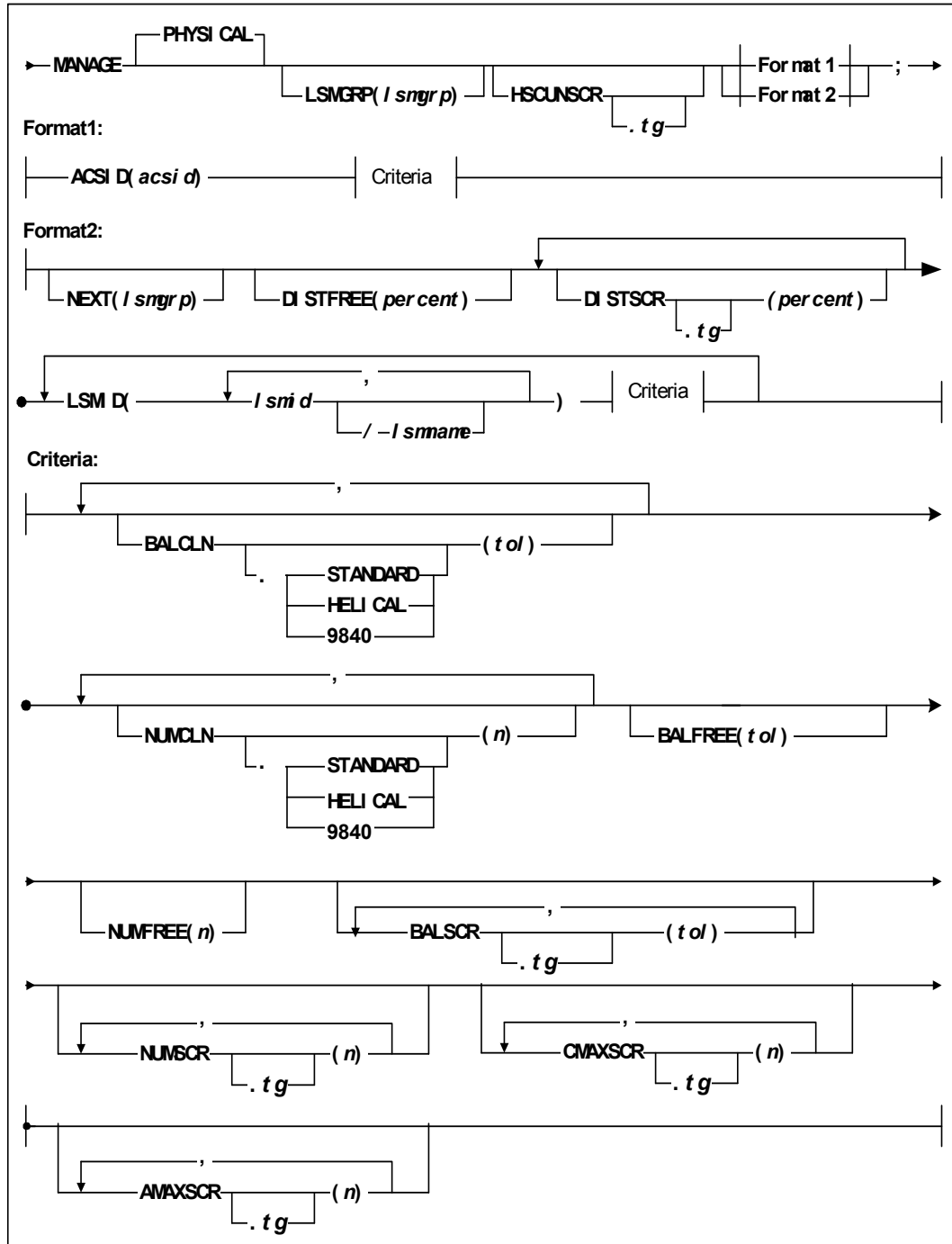

FIGURE 4-3 MANAGE PHYSICAL Statement Syntax

Parameters

LSMGRP

specifies the unique name of the LSM group, which is a maximum of 10 characters.

The default LSM group name is LSMGRP plus the number of the MANAGE PHYSICAL statement. For example, the default group name for the first MANAGE PHYSICAL statement is LSMGRP1.

lsmgrp

the LSM group name.

HSCUNSCR

specifies that LCM sets the HSC scratch status to “not scratch”.

You can mark scratch volumes as HSCUNSCR to prevent HSC from selecting them for scratch mounts (for example, to keep a reserve of scratch volumes in an ExtendedStore LSM).

tg

specifies the tape group. You can specify HSCUNSCR for multiple tape groups, but not multiple times for the same tape group.

Specify tape groups if you have multiple subpools or if you have specified the MEDIA keyword on a SUBPOOL statement. If you do not specify tape groups, HSCUNSCR applies to all tape groups. If you do not specify tape groups and SUBPOOL statements, HSCUNSCR applies to tape group GENERAL..

ACSID

specifies that an entire ACS is to managed by this statement and only applies to Format 1.

acsid

a hexadecimal ACS ID (x'00' to x'FF').

NEXT

specifies the name of the LSM group below this group in an LSM group hierarchy and only applies to Format 2. LCM demotes volumes (moves them down the hierarchy) as needed to make room in this LSM group.

lsmgrp

the LSM group.

DISTFREE

specifies that LCM distributes free cells among the LSM subgroups defined by this MANAGE PHYSICAL statement proportional to the specified NUMFREE value for each subgroup.

percent

as a percentage, how close to exact LCM attempts to make this distribution. The larger the value, the less work LCM will have to do to achieve a balance.

DISTSCR

specifies that LCM distributes scratch volumes among the LSM subgroups defined by this **MANAGE PHYSICAL** statement proportional to the specified **NUMSCR** value for each subgroup.

tg

Specifies the tape group. You can specify **DISTSCR** for multiple tape groups, but not multiple times for the same tape group.

Specify tape groups if you have multiple subpools or if you have specified the **MEDIA** keyword on a **SUBPOOL** statement. If you do not specify tape groups, **DISTSCR** applies to all tape groups. If you do not specify tape groups and **SUBPOOL** statements, **DISTSCR** applies to tape group **GENERAL**.

percent

as a percentage, how close to exact LCM attempts to make this distribution. The larger the value, the less work LCM will have to do to reach a scratch distribution.

LSMID

defines an LSM subgroup consisting of one or more LSMs that LCM manages using the same criteria. Any criteria following the LSM subgroup definition will apply to the LSM subgroup as a whole, not to each individual LSM in the subgroup.

lsmid

a hexadecimal LSM ID (00:00 to FF:7F).

lsmname

the name to use for this LSM in reports, which is 1 to 10 characters.

BALCLN

specifies that LCM balances the following types of cleaning cartridges across the LSMs specified by the **ACSID** or **LSMID** keyword.

STANDARD

standard cleaning cartridges (the default).

HELICAL

helical cleaning cartridges.

9840

9840 cleaning cartridges.

STK2W

9940 cleaning cartridges

tol

specifies the cleaning cartridge balance tolerance as a non-negative integer. For example, **BALCLN** applies to 6 LSMs having a total of 12 cleaning cartridges. A "perfect" cleaning cartridge balance mean each LSM has 2 cleaning cartridges. A tolerance of 1 means that LCM should consider the cleaning cartridges are balanced if each LSM contains 1 to 3 cleaning cartridges.

NUMCLN

specifies the levels for the following types of cleaning cartridges for the LSMs specified by the associated ACSID or LSMID keyword.

STANDARD

standard cleaning cartridges (the default).

HELICAL

helical cleaning cartridges.

9840

9840 cleaning cartridges.

STK2W

9940 cleaning cartridges

n

specifies the cleaning cartridge level as a nonnegative integer.

BALFREE

specifies that LCM balances free cells across the LSMs specified by the ACSID or LSMID keyword.

tol

specifies the free cell balance tolerance as a non-negative integer. For example, **BALCLN** applies to 6 LSMs having a total of 90 free cells. A “perfect” free cell balance means each LSM has 15 free cells. A tolerance of 5 means that LCM considers the free cells are balanced if each LSM contains 10 to 20 free cells.

Even if you do not specify **BALFREE**, LCM will try to keep free cells balanced as much as possible when selecting LSMs for enters and ejects.

NUMFREE

specifies the free cell level for the LSMs specified by the ACSID or LSMID keyword.

n

specifies the free cell level as a nonnegative integer.

BALSCR

specifies that LCM balances scratch volumes across the LSMs specified by the ACSID or LSMID keyword.

tg

Specifies the tape group. You can specify **BALSCR** for multiple tape groups, but not multiple times for the same tape group.

Specify tape groups if you have multiple subpools or if you have specified the **MEDIA** keyword on a **SUBPOOL** statement. If you do not specify tape groups, **BALSCR** applies to all tape groups. If you do not specify tape groups and **SUBPOOL** statements, **BALSCR** applies to tape group **GENERAL**.

tol

specifies the scratch volume balance tolerance as a non-negative integer. For example, **BALSCR** applies to 6 LSMs having a total of 90 scratch volumes in subpool a and 60 scratch volumes in subpool b. A “perfect” scratch volume balance means each LSM has 15 scratch volumes in

subpool a and 10 scratch volumes in subpool b. A tolerance of 8 means that LCM considers the scratch volumes to be balanced if the number of scratch volumes for each subpool is within 8 volumes of that “perfect” balance.

Even if you do not specify **BALSCR**, LCM will try to keep scratch volumes balanced through LSM selection for enters and ejects.

NUMSCR

specifies the scratch volume level for each LSM specified by the **ACSID** or **LSMID** keyword.

tg

Specifies the tape group. You can specify **NUMSCR** for multiple tape groups, but not multiple times for the same tape group.

Specify tape groups if you have multiple subpools or if you have specified the **MEDIA** keyword on a **SUBPOOL** statement. If you do not specify tape groups, **NUMSCR** applies to all tape groups. If you do not specify tape groups and **SUBPOOL** statements, **NUMSCR** applies to tape group **GENERAL**.

n

specifies the scratch volume level as a nonnegative integer.

CMAXSCR

specifies the conditional maximum scratch volumes across the LSMs specified by the **ACSID** or **LSMID** keyword. LCM will demote or eject scratch volumes over the maximum as needed.

tg

Specifies the tape group. You can specify **CMAXSCR** for multiple tape groups, but not multiple times for the same tape group.

Specify tape groups if you have multiple subpools or if you have specified the **MEDIA** keyword on a **SUBPOOL** statement. If you do not specify tape groups, **CMAXSCR** applies to all tape groups. If you do not specify tape groups and **SUBPOOL** statements, **CMAXSCR** applies to tape group **GENERAL**.

n

specifies the conditional maximum scratch volumes as a nonnegative integer.

AMAXSCR

specifies the absolute maximum scratch volumes across the LSMs specified by the **ACSID** or **LSMID** keyword. LCM will always demote or eject scratch volumes over the maximum.

tg

Specifies the tape group. You can specify **AMAXSCR** for multiple tape groups, but not multiple times for the same tape group.

Specify tape groups if you have multiple subpools or if you have specified the **MEDIA** keyword on a **SUBPOOL** statement. If you do not specify tape groups, **AMAXSCR** applies to all tape groups. If you do not specify tape groups and **SUBPOOL** statements, **AMAXSCR** applies to tape group **GENERAL**.

n

specifies the absolute maximum scratch volumes as a nonnegative integer.

Usage

Use the following guidelines for the `MANAGE PHYSICAL` statement:

- Use `Format1` to manage an entire ACS as a unit. Use `Format2` to individually manage one LSM, all LSMs in an ACS, or some subset of LSMs in an ACS. The criteria specified after an `LSMID` parameter and before any additional `LSMID` parameters apply only to the LSMs specified in that `LSMID` parameter.
- LCM uses HSC `VOLATTR` statements to identify a volume's media type. StorageTek strongly recommends that you maintain identical `VOLATTR` statements on all hosts or unpredictable results can occur.
- The HSC parameter `CLNPFEX` specifies a cleaning cartridge prefix. LCM requires this prefix to identify volumes as cleaning cartridges.
- LCM Cleaning cartridge management only ensures that you have sufficient cleaning cartridges in your LSMs and that their distribution is balanced across the LSMs. You must use HSC to specify the cleaning cartridge prefix and to specify how many times HSC mounts a cleaning cartridge before making it not usable.
- The `HSCUNSCR` requires you to specify the `OPTIONS SYNC` parameter to force LCM to do HSC scratch synchronization; for more information, see ["OPTIONS" on page 114](#).

Restrictions

Note the following restrictions for the `MANAGE PHYSICAL` statement:

- Do not specify more than one `MANAGE PHYSICAL` statement for a specific LSM.
- Specify `MANAGE PHYSICAL` statements after all `SUBPOOL` statements.
- In Format 2, LSM group hierarchies cannot span ACS boundaries.
- The `NEXT` keyword establishes hierarchies. Do *not* create cycles or loops among LSM groups.
- You cannot use the `MANAGE PHYSICAL` statement to manage VTVs or to specify VTV tape groups for scratch criteria. For more information on using the `MANAGE VIRTUAL` statement to manage VTVs, see [“MANAGE VIRTUAL” on page 105](#).
- You cannot specify undefined tape groups on the `HSCUNSCR`, `DISTSCR`, `BALSCR`, `NUMSCR`, `CMAXSCR`, or `AMAXSCR` parameters. You cannot use these parameters to establish defaults for all tape groups that can then be overridden for a subset of tape groups.
- `NUMSCR` must be less than `CMAXSCR`, which must be less than `AMAXSCR`.
- Do not specify a `SUBPOOL` statement to cover cleaning cartridges because this disables LCM cleaning cartridge management (including the `MANAGE BALCLN` and `NUMCLN` parameters).

Note that LCM automatically defines the `Cleaning` subpool for cleaning cartridges, under which cleaning cartridge management is enabled. The cleaning `Cleaning` subpool contains the following tape groups:

- `Cleaning _Standard` - includes all standard cleaning cartridges known to LCM and
- `Cleaning _Helical` - includes all helical cleaning cartridges known to LCM.

You cannot specify these cleaning cartridge tape groups on the `HSCUNSCR`, `DISTSCR`, `BALSCR`, `NUMSCR`, `CMAXSCR`, or `AMAXSCR` keywords.

MANAGE VIRTUAL

The MANAGE VIRTUAL tells LCM to manage VTVs.

Syntax

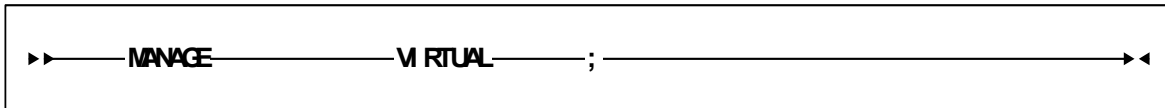

FIGURE 4-4 MANAGE VIRTUAL Statement Syntax

Parameters

None.

Usage

Use the MANAGE VIRTUAL statement to tell LCM to manage VTVs.

If you specify the MANAGE VIRTUAL statement in a parameter file, you can assign methods to VTVs on any of the following statements:

- "DATASET" on page 86
- "LOCATION" on page 91
- "OPTIONS" on page 114 (EXTERNAL parameter)
- "SET METHOD" on page 134
- "SUBPOOL" on page 140

If you do not specify the MANAGE VIRTUAL statement in a parameter file, you cannot use LCM to manage VTVs, but you can produce reports that include information about VSM resources.

METHOD

The METHOD statement defines an LCM management method for nonscratch volumes. You can assign management methods to any nonscratch Nearline volume that resides in a managed LSM. Management attributes for physical tape volumes allow you to specify policies that control where tapes are stored, when they should be ejected, and in which order LCM can choose tapes to move or eject during library content management. See [“MANAGE PHYSICAL” on page 96](#) for information on identifying LSMs to be managed.

You can also assign management methods to any nonscratch VTV if the MANAGE VIRTUAL statement is specified. Management attributes for VTVs allow you to specify policies controlling for consolidations, migrations, recalls, exports, and so on. See [“MANAGE VIRTUAL” on page 105](#) for more information.

See [“Usage” on page 112](#) for information about assigning a method to a volume.

Syntax

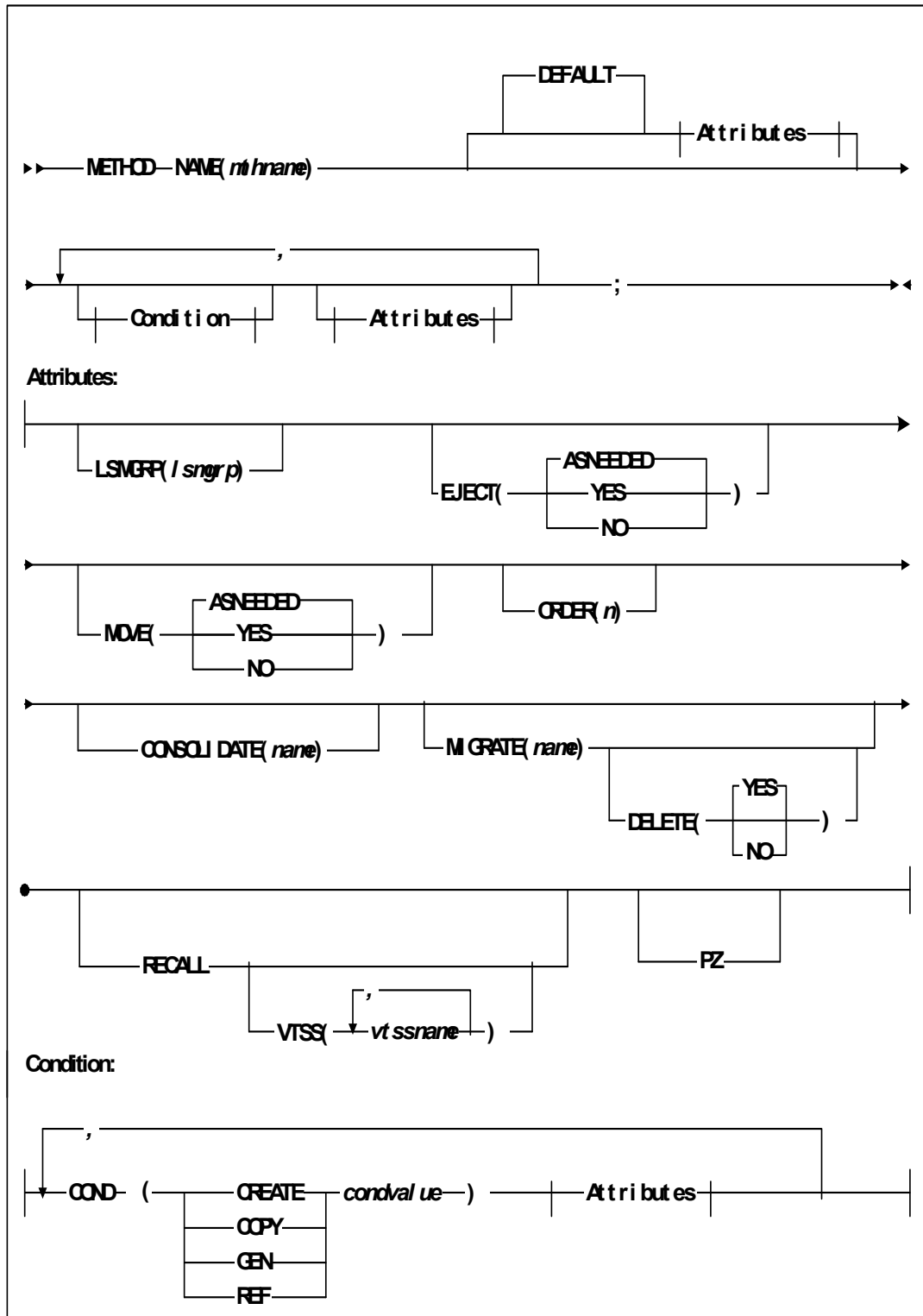

FIGURE 4-5 METHOD Statement Syntax

Parameters

TABLE 4-3 lists the valid abbreviations for the METHOD statement.

TABLE 4-3 METHOD Statement Abbreviations

Statement or Parameter	Abbreviation
METHOD	MTH
NAME	MTHNAME
EJECT	EJ
ASNEEDED	NEED
YES	Y
NO	N
ORDER	ORD
EQ	=
GE	>=
GT	>
LE	<=
LT	<
NE	≠

NAME

specifies the method name.

`mthname`

the unique method name, which is 1 to 10 characters.

DEFAULT

specifies the default attributes to use for this management method.

The attributes specified here will be used for a volume when none of the specified conditions, if any, apply.

The attributes specified here do **not** change the default values for attributes of conditions.

COND

specifies the condition that assigns the associated attributes to the volume.

You can specify up to 255 conditions on a single METHOD statement. LCM applies the attributes of the first COND parameter that evaluates as true. If no specified condition is true, LCM assigns the method's default attributes.

CREATE

compare the number of days since the data set was created to the specified value.

This value is equivalent to the DaysSinceCreation field of the REPORT VOLUME and SET METHOD statements.

COPY

compare the copy number of the data set to the specified value. For generation data sets, the copy number is the copy for a specific generation number.

1 denotes the most recently created copy of the data set (from TMS information), 2 denotes to the next most recently created copy, and so on.

This value is equivalent to the Copy field of the REPORT VOLUME and SET METHOD statements.

GEN

compare the generation of the data set to the specified value. If the data set on the volume is not a generation data set, LCM ignores the condition.

1 denotes the most current absolute generation number of the data set, 2 denotes the next most current number, and so on.

LCM uses the TMS tape catalog, not the MVS data set catalog facility, to determine generation numbers.

This value is equivalent to the Generation field of the REPORT VOLUME and SET METHOD statements.

REF

compare the number of days since the data set was last referenced to the specified value.

This value is equivalent to the DaysSinceReference field of the REPORT VOLUME statement. The SET METHOD statement does not have an exact equivalent field for the REF option. However, you can specify DaysSinceReferenceTms (RTDAYS) on the WHEN option of the SET METHOD statement, which is similar to the DaysSinceReference field for volumes defined to the TMS.

Logical Operators

specify the comparison between the keyword and the specified value.

EQ

equal to (=).

GE

greater than or equal to (>=).

GT

greater than (>).

LE

less than or equal to (<=).

LT

less than (<).

NE

not equal to (\neq).

value

the value compared with the keyword specified for this condition. Valid values are 1 to 9999.

LSMGRP

the name of the LSM group where volumes managed by this method should reside. If the volume is not currently in that LSM group, LCM moves it to the LSM within that group that can best accommodate the volume. LSMGRP applies to *only* physical Nearline volumes, not VTVs.

lsmgrp

the LSM group as specified on the MANAGE PHYSICAL LSMGRP parameter; for more information, see “MANAGE PHYSICAL” on page 96.

EJECT

specifies when, if ever, LCM ejects a volume managed by this method. EJECT applies to *only* physical Nearline volumes, not VTVs.

ASNEEDED

Eject when free cells are needed (the default).

YES

Always eject.

NO

Never eject.

MOVE

Specifies when, if ever, LCM moves a volume managed by this method. Applies only to physical Nearline volumes, not to VTVs.

ASNEEDED

Move this volume as needed to meet content management goals.

YES

Always move this volume. Forces LCM to move the volume even if it is only to another cell in the same LSM. This feature can be used, for example, to force the HSC to perform errant volume recovery on the volume.

NO

Do not move this volume unless explicitly instructed to do so. Keeps LCM from moving the volume for content management purposes.

Note –

- If the LSMGRP parameter is also specified and the volume is not in the correct LSM group, LCM will move the volume to the specified LSM group. This is considered an explicit move that overrides MOVE(NO).
 - Specifying MOVE(NO) does not in itself restrict LCM from ejecting the volume if needed. Use the EJECT(NO) attribute to keep LCM from ejecting the volume.
-

ORDER

Specifies the “pick order” LCM uses to pick a volume managed by this method for either ejection or demotion. ORDER applies to *only* physical Nearline volumes, not VTVs.

LCM ejects or demotes only the number of volumes required to create sufficient free cells. LCM begins with ORDER(1) and continues through the highest specified order. Within an order, LCM selects the least recently referenced volumes until all volumes of that order have been processed.

n

the pick order. Valid values are 1 to 100 and the default is 50.

CONSOLIDATE

consolidate VTVs managed by this method. CONSOLIDATE applies to *only* VTVs, not physical Nearline volumes. MIGRATE, CONSOLIDATE, and RECALL are mutually exclusive.

name

specifies the 1 to 8 character name of a group of consolidated VTVs.

If you specify the same group name on different methods or on different conditions within the same method, all VTVs with the same group name are consolidated on a common set of consolidation MVCs. Use different consolidation group names to segregate different VTV groups on separate sets of consolidation MVCs.

MIGRATE

Migrate VTVs managed by this method that do not already have a migration copy. MIGRATE *only* applies to VTVs, not Nearline physical volumes. MIGRATE, CONSOLIDATE, and RECALL are mutually exclusive.

DELETE

specifies whether to delete the VTVs from the VTSS after migration completes. You must specify MIGRATE before you specify DELETE.

YES

delete VTVs after migration completes (the default).

NO

do not delete VTVs after migration completes.

You cannot specify DELETE unless you first specify MIGRATE.

RECALL

Recall VTVs managed by this method that are not already VTSS-resident. RECALL *only* applies to VTVs, not Nearline physical volumes. MIGRATE, CONSOLIDATE, and RECALL are mutually exclusive.

VTSS

specifies where the VTVs are recalled as follows:

- If you do not specify a VTSS (the default), VTCS recalls the VTVs to the VTSS of creation unless this VTSS does not have sufficient space. In this case, VTCS recalls the VTVs to the VTSS with the most available space.
- If you specify a single VTSS, VTCS attempts to recall the VTVs to the specified VTSS unless this VTSS does not have sufficient space. In this case, VTCS recalls the VTVs to the VTSS with the most available space.
- If you specify a list of VTVs, VTCS attempts to recall the VTVs to the VTSS of creation if it is on the list, otherwise VTCS recalls the VTVs to the VTSS with the most available space on the list.

vtss-name

a VTSS name.

PZ

Specifies that volumes managed by this method should reside within the Performance Zone (PZ) of a Streamline library. The PZ is a defined area of an LSM that is closest to the transports. Cartridges residing in this area have faster mount and dismount times. For more information, see [“Using the Performance Zone” on page 415](#).

Usage

The METHOD statement only defines an LCM management method. To assign a method to a volume, first define the method, then use any of the following statements:

- [“DATASET” on page 86](#)
- [“LOCATION” on page 91](#)
- [“OPTIONS” on page 114](#)
- [“SET METHOD” on page 134](#)
- [“SUBPOOL” on page 140](#)

An unexpired nonscratch volume (that is not being ignored) has its management method assigned by the *first* of the above statements (except OPTIONS) that covers the volume. If, for example, you want a volume’s data set name to determine its management method, either specify a method on *only* a DATASET statement, or specify the DATASET statement in the parameter file before any other statements that assign methods (such as LOCATION).

You can use the OPTIONS statement to assign methods to the following types of volumes:

- Externally managed in the TMS (EXTERNAL parameter)
- Not defined in a TMS (HSCONLY parameter)
- Specifically managed by a Method file entry (METHODFILE parameter).

For more information, see [“OPTIONS” on page 114](#).

You can use the SET METHOD statement to conditionally override the method assignment from *any* previous statement or option; for more information, see [on page 134](#).

Also note that LCM predefines several methods described in [TABLE 4-4](#).

TABLE 4-4 LCM Predefined Management Methods

Method Name	Parameter Values
Cleaning	LCM internal use only
Eject	eject(yes)
MVC	eject(no) move(no)
NeverEject	eject(no)
PickFirst	eject(asneeded) order(1)
PickLast	eject(asneeded) order(100)
Scratch	LCM internal use only
Standard (default method)	eject(asneeded) order(50)

You can specify any of the methods described in [TABLE 4-4](#) *except* for **Scratch** and **Cleaning**, which LCM uses to manage scratch volumes and cleaning cartridges. LCM also lists methods **Scratch** and **Cleaning** on reports. Do not define a method using the name of a predefined method!

Note – If no statement assigns a method to a volume, LCM will assign a default method to the volume. The default method for Multiple Volume Cartridges (MVCs) is MVC. The default method for all other volumes is STANDARD.

OPTIONS

The `OPTIONS` statement defines global LCM processing options.

Syntax

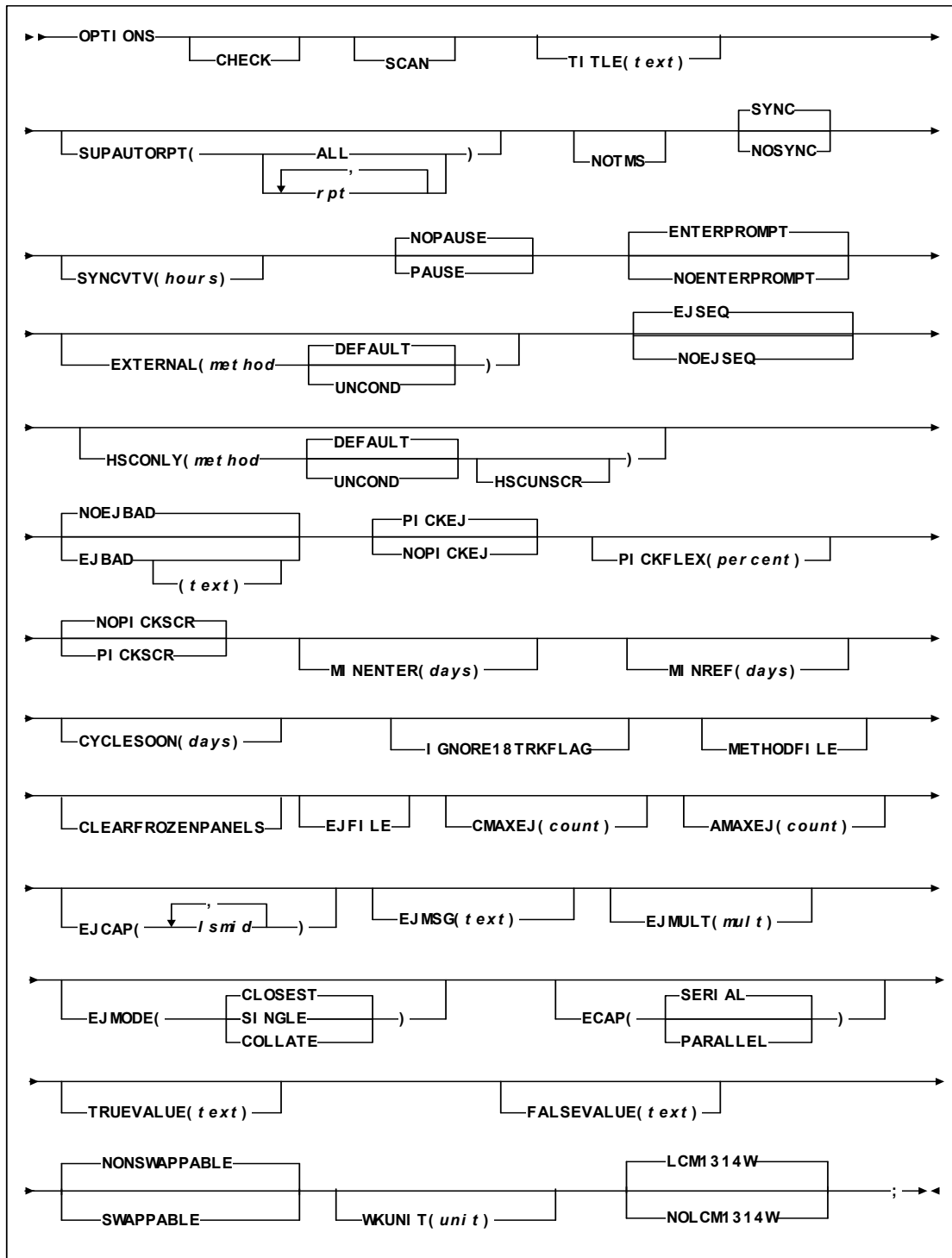

FIGURE 4-6 OPTIONS Statement Syntax

Parameters

TABLE 4-5 lists the valid abbreviations for the OPTIONS statement.

TABLE 4-5 OPTIONS Statement Abbreviations

Statement or Parameter	Abbreviation
OPTIONS	OPT
ENTERPROMPT	ENPROMPT
NOENTERPROMPT	NOENPROMPT
MINENTER	MINENT
CELLCNT	CC
CLEARFROZENPANELS	CLRFZPNL
CONSOLIDATE	CONS
DATASET	DS
EJECT	EJ
NONSCRCNT	NSC
OPERATOR	OP
SCRCNT	SC
SUMMARY	SUM
SWAPPABLE	SWAP
NONSWAPPABLE	NONSWAP

CHECK

specifies that LCM:

- Simulates managing LSMs and VSM as defined by the control statements in the parameter file used for this batch job, but does not consolidate, eject, or move volumes or modify the HSC CDS (including scratch synchronization).
- Produces reports and creates the Eject File.

Use CHECK to verify a parameter or configuration file and produce reports without having LCM take actions.

SCAN

specifies that LCM scans control statement syntax and creates a Parameter File listing with any errors, but does not produce reports or perform any management action.

If you specify CHECK and SCAN, LCM operates in SCAN mode.

TITLE

specifies a main title line to be printed in LCM report headings. No title is printed if you do not specify a title.

title-line

the text of the title line, which is a maximum of 70 characters. Enclose the text in single quotes if it contains blanks or other special characters. For more information, see ["Character Data" on page 17](#).

SUPAUTORPT

suppresses the following standard reports:

ALL

all reports *except* for the Enter Report.

CELLCNT

Cell Count Report.

CONSOLIDATE

Consolidation Report.

DATASET

Data Set Report.

EJECT

Eject Report.

EXPORT

Export Report.

NONSCRcnt

Nonscratch Count Report.

OPERATOR

Operator Report.

SCRcnt

Scratch Count Report.

SUMMARY

Summary Report.

Note – LCM does not generate any standard reports if the parameter file does not include a **MANAGE** or **ACTION** statement.

NOTMS

specifies that LCM runs without a TMS. When you specify **NOTMS**, LCM:

- Does not try to locate ddname **LCMTMSDB**,
- Does not allow any **TMS** statements,
- Uses the last mounted date in the HSC CDS as the last referenced date, and
- Issues a message that LCM is running without a TMS.

For more information, see [“Running LCM without a TMS” on page 127](#).

SYNC

instructs LCM to synchronize the HSC scratch status of volumes in managed LSMs with that of the TMS.

SYNC applies to all non-ignored volumes in LSMs controlled by **MANAGE PHYSICAL** statements.

If the HSC scratch status for a volume does not match that of the TMS, LCM updates the HSC scratch status to match. The TMS is **not** updated by this operation.

SYNC requires that LCM be running with a TMS.

NOSYNC

instructs LCM not to perform scratch status synchronization processing.

SYNCVTV (24 | hours)

specifies that LCM synchronizes HSC scratch status of VTVs with TMS scratch status.

hours

specifies the minimum number of hours since last reference that are required for a VTV before it is eligible for VTV scratch status synchronization. If the latest reference time for a VTV is within *hours*, LCM will treat the volume as nonscratch, regardless of its TMS status. It will not be scratched. This “grace period” is intended to avoid potential data loss when DELSCR(YES) is in effect and LCM receives TMS information that is slightly out of date. The range of hours is 0 to 999, where zero indicates no grace period.

The default value for *hours* is 24.

Note – The grace period for the SYNCVTV option is set to 24 hours to ensure that sites that create a single extract from their tape management system for use with all LCM runs for the day. As the information becomes more and more stale as the day progresses, care must be taken that this 'stale' information is not used to synchronize VTV scratch status. If using CA-1, CA-TLMS, Automedia (Zara), Control-M Tape (Control-T) or the DFSMSrmm API, the value can be reduced as long as it meets the following minimum value...Maximum number of hours a VTV may be mounted without being opened plus maximum number of hours a VTV may be mounted after open plus at least one hour. For tape management systems where an extract file is used, DFSMSrmm using EDGHSKP produced extract file or users of the TMS COMMON interface, the maximum number of hours between the start of the creation of the extract file and the start of the LCM run should be added to the earlier formula. In some cases, this will exceed the default of 24 hours and the higher value should be used. In general, most users should be able to use the default value with no issue. The maximum impact after the first SYNCVTV run on LCM 7.0 and above using the default or higher value is that a greater number of VTVs will be bypassed for scratch processing on each SYNCVTV run, however the number of VTVs made scratch on any given day will be the same as if there were no grace period.

Caution – When you scratch a VTV with the HSC MGMTclas statement DELSCR YES attribute, VSM erases the VTV data at scratch synchronization time, which eliminates the ability to “unscratch” a VTV to recover data!

PAUSE | NOPAUSE

specifies whether LCM pauses before starting actions. PAUSE specifies that LCM issues console message LCM4016E and leaves it highlighted until the operator enters a RESUME command.

Note – Scratch synchronization is **not** affected by PAUSE.

ENTERPROMPT | NOENTERPROMPT

specifies whether LCM prompts the operator (via message LCM4019A) to enter volumes. The default (ENTERPROMPT) is to prompt the operator.

EXTERNAL (method DEFAULT | UNCOND)

specifies how LCM manages nonscratch volumes defined as externally managed in the TMS as follows:

method

specifies the management method.

DEFAULT

assign the specified method only if no other statement in the parameter file covers the same volume (the default).

UNCOND

always assign the method indicates unless overridden by a SET METHOD statement or an entry in the method file with the 'U' indicator.

Note –

- You can use EXTERNAL to assign a method to volumes controlled by DFHSM, but a DATASET statement specifying the prefix for migration and backup data sets is more flexible.
- If no statement assigns a method to a volume, LCM will assign a default method to the volume. The default method for Multiple Volume Cartridges (MVCs) is MVC. The default method for all other volumes is STANDARD.

HSCONLY

specifies how LCM manages nonscratch volumes that are defined in the HSC CDS but not defined in a TMS as follows:

method

specifies the management method.

DEFAULT

assign the specified method only if no other statement in the parameter file covers the same volume (the default).

UNCOND

always assign the method indicates unless overridden by a SET METHOD statement or an entry in the method file with the 'U' indicator.

HSCUNSCR

mark volumes not in the TMS catalog as non-scratch in the HSC CDS.

Note – If no statement assigns a method to a volume, LCM will assign a default method to the volume. The default method for Multiple Volume Cartridges (MVCs) is MVC. The default method for all other volumes is STANDARD.

For more information, see "Running LCM without a TMS" on page 127.

EJSEQ | NOEJSEQ

specifies whether HSC should honor the volume sequence presented by LCM for ejects for SL8500 LSMs. The default is to honor the LCM order (EJSEQ).

NOEJBAD | EJBAD

specifies whether LCM ejects all scratch volumes marked defective by the TMS. The default is to not eject defective volumes (NOEJBAD).

Note – You can also specify this parameter for a specific TMS on the TMS statement.

text

specifies the text of message SLS1251E that appears when the CAP door is unlocked to eject defective volumes. The text is a maximum of 32 characters. Enclose the text in single quotes if it contains blanks or other special characters. For more information, see [“Character Data” on page 17](#).

PICKEJ | NOPICKEJ

PICKEJ (the default) specifies that LCM picks volumes for ejection whose management method specifies EJECT(ASNEEDED) and processes these volumes using the ORDER values.

NOPICKEJ specifies that LCM only ejects volumes whose management method specifies EJECT(YES).

PICKFLEX (10 | percent)

specifies the amount of flexibility LCM has when it picks volumes within an LSM group for demotion or ejection that have the same pick order.

percent

determines the amount of flexibility, where:

- 0 - no flexibility, LCM always picks the least recently referenced volume.
- 1 - 100, LCM has increasing flexibility to pick a volume that has been referenced in the specified percentage of days less than the least recently referenced volume.

Note – If you give LCM some flexibility, it will tend to keep the content of your LSMs more balanced without requiring as much cartridge movement.

Note that because PICKFLEX is a percentage, the flexibility that LCM has increases as the least recent reference days goes up. For example, with the default PICKFLEX of 10 percent, LCM would have no flexibility if the least recently referenced volume was referenced in the last 1 to 9 days, 1 day flexibility if it was referenced in the last 10 to 19 days, 2 days flexibility if it was referenced in the last 20 to 29 days, and 10 days flexibility if it was referenced in the last 100 to 109 days.

PICKSCR | NOPICKSCR

PICKSCR specifies that LCM lists on the Enter Reports which non-LSM scratch volumes should be entered to replenish LSM scratch counts. PICKSCR applies for all LSMs LCM manages during execution.

Note – The media type for volumes not in an LSM is determined solely by HSC VOLATTR statements. If these VOLATTR statements do not correctly specify the media type of candidate scratch volumes, PICKSCR may select incorrect media types for scratch volume entry.

NOICKSCR (the default) specifies that LCM does not list on the Enter Reports which non-LSM scratch volumes should be entered to replenish LSM scratch counts. Specifying NOICKSCR requires the operator to select scratch volumes for entry. NOICKSCR applies for all LSMs LCM manages during execution.

For both PICKSCR and NOICKSCR, if more non-LSM scratch volumes need to be entered for a tape group than are defined to the TMS, the Scratch Count Report indicates this additional need for the tape group.

MINENTER (2 | days)

specifies that LCM does not eject volumes entered since the specified number of days. MINENTER does not apply to volumes whose assigned method specifies that they should always be ejected.

For multi-volume data sets whose volumes are processed as a unit, LCM uses the most recent enter date of any volume in the set.

For volumes defined in a TMS, MINENTER applies to data sets on nonscratch volumes that were created before volume was entered. This prevents LCM from ejecting a newly entered volume with data you wish to process. However, if the data on the volume was created after the volume was entered, MINENTER does not apply.

MINENTER applies to all HSC-only nonscratch volumes because no TMS is available to provide data set information for them.

days

days since the volume was entered. Valid values are 0 to 999. The default value is 2 days. A value of 0 means LCM will eject volumes regardless of when they were entered.

MINREF (2 | days)

specifies that LCM does not eject volumes referenced since the specified number of days. MINREF does apply to volumes whose assigned method specifies that they should always be ejected.

For multi-volume data sets whose volumes are processed as a unit, LCM uses the most recent reference date of any volume in the set.

days

days since the volume was referenced. Valid values are 0 to 999. The default value is 2 days. A value of 0 means LCM will eject volumes regardless of when they were referenced.

CYCLESOON

specifies that LCM does not eject volumes that expire (become scratch) within the interval specified by *days*. The CYCLESOON parameter:

- Requires the TMS to assign an expiration date to the volume.
- Does not apply to volumes with METHOD EJECT(YES).
- Applies to volumes in all LSMs that LCM manages.

days

the expiration interval, in days. Valid values are 1 to 99 and there is no default.

IGNORE18TRKFLAG

specifies that LCM treats all volumes in the TMS as cartridge tapes (not reel tapes).

IGNORE18TRKFLAG also requires PICKSCR to cause LCM to select scratch volumes for entry into managed LSMs. If you specify PICKSCR but not IGNORE18TRKFLAG, LCM selects only non-LSM scratch volumes that are marked as cartridge tapes in the TMS for entry into an LSM.

Note – You can also specify this parameter for a specific TMS on the TMS statement.

METHODFILE

specifies that LCM reads the method file specified by ddname LCMMTHIN. Each record in specifies a volser and the management method for that volume; for more information, see [“METHODFILE Record” on page 409](#).

Volumes specified in the method file will only be assigned the specified method if they are:

- not expired,
- not being ignored,
- are nonscratch,
- are not cleaning cartridges, and
- reside in a managed LSM.

CLEARFROZENPANELS

specifies that LCM removes volumes from frozen panels in managed LSMs. The HSC SET FREEZE utility marks panels frozen; for more information, see *HSC System Programmer's Guide*. LCM uses moves and ejects as needed to remove all volumes from frozen panels in managed LSMs. CLEARFROZENPANELS does not apply to non-managed LSMs.

EJFILE

specifies that LCM does take any actions other than scratch status updates and creates an Eject File (even if you specify the CHECK parameter). For more information, see [“The LCM Eject File” on page 128](#).

CMAXEJ

specifies the conditional maximum number of ejects that LCM can perform during this run. The conditional maximum specifies the total number of ejects, but only limits ejects chosen by LCM to meet content management policies. Explicit eject specified by ACTION EJECT statements and by the method attribute EJECT(YES) are processed first. Then LCM ejects volumes as needed to meet content management policies. If the total number of ejects exceeds the specified CMAXEJ value, LCM stops ejecting volumes even if the content management policies are not satisfied.

LCM stops ejects on a data set boundary, but will not exceed the specified value. Therefore, actual ejects can be slightly lower than the specified value.

ejects

the number of ejects, in volumes. Valid values are 1 to 999999 and there is no default.

AMAXEJ

specifies the absolute maximum number of ejects that LCM can perform during this run. LCM limits ejects to the specified value, regardless of how many volumes have been selected by ACTION EJECT statements or assigned methods with the EJECT(YES) attribute.

LCM stops ejects on a data set boundary, but will not exceed the specified value. Therefore, actual ejects can be slightly less than the specified value.

ejects

the number of ejects, in volumes. Valid values are 1 to 999999 and there is no default.

EJCAP

specifies a list of one or more LSMs whose CAPs are used for cartridge ejections. If this list does not contain at least one LSM for each managed ACS, LCM assumes that all LSMs in that ACS are available for use (which is also the default if you do not specify a value for EJCAP). ACTION EJCAP overrides this setting on the OPTIONS statement.

Alternatively, you can specify a specific CAP within an LSM.

lsmid

the hexadecimal LSM ID (00:00' to FF:7F'). Note that LCM will not use priority CAPs.

capid

the CAP ID in format *aa-ll-cc*. You can use the LCM DISPLAY, PAUSE, REDIRECT, and RESUME commands to manage LCM activity for specific CAPs; for more information, see [“LCM Operator Commands” on page 379](#).

EJMSG

specifies the text of the eject message (SLS1251E).

If you do not specify this parameter, LCM uses a text of 'Action Stmt' followed by a number indicating which ACTION statement is controlling the ejects. For example, if the fourth ACTION statement is controlling the ejects, the LCM job name is LCM, and the CAP is 00:00, the following messages will be issued when the CAP door is unlocked:

```
SLS0259A CAP PROCESSING TERMINATED; EMPTY CAPID 00:00
```

```
SLS1251E CAPID 00:00 (LCM): ACTION STMT 1
```

text

the message text, which is a maximum of 32 characters (longer strings are truncated to 32 characters). Enclose the character string in single quotes if it contains blanks or other special characters.

Any of the fields in the “ACTION Statement Fields” section of *LCM Quick Reference* can be specified in the text string by placing the ampersand character (“&”) before the field and a period (“.”) after the field. The period is optional if the character immediately following the field is not an alphanumeric or national character.

Note – A new EJMSG is generated for each CAP break using the text you specify. For example, if you specify CAP break on location name, you can include &locationname. as part of your message text as follows:

```
EJMSG("Location &locationname.')
```

EJMULT

eject volumes in multiples specified by *mult*. For example, for EJMULT(10), LCM ejects volumes in multiples of ten, which can include situations such as ejecting forty volumes at a time through an Enhanced CAP.

Note – You can use EJMULT to force volume ejections in amounts that fit evenly into cases or magazines for transport. For example, to fill a 10-cell magazine evenly, specify EJMULT(10).

EJMULT has no effect on the selection of a CAP for eject processing. For example, specifying EJMULT(40) does not prevent ExLM from selecting a 21-cell CAP for ejection.

StorageTek recommends that you do **not** specify an EJMULT value that is larger than the capacity of the smallest CAP used. For example, if you specify EJMULT(40) and a 21-cell CAP is used for ejects, LCM ejects volumes in batches of 40, which means that the operator has to empty the CAP twice (21 volumes followed by 19 volumes) for each batch of 40 volumes.

StorageTek also recommends that you do **not** specify large values (such as 200) for EJMULT. PAUSE commands (without the IMMED operand) do not take effect for a specific CAP until the current batch has been ejected, so large EJMULT values increase the delay before PAUSE commands take effect. There is no impact on PAUSE commands that specify the IMMED operand. The EJMULT parameter is only valid if CAPs of multiple LSMs are included in the EJCAP list and are available. ACTION EJMULT overrides this setting on the OPTIONS statement.

mult

the multiple that LCM uses to eject volumes. Valid values are 1 to 500 inclusive and the default is 1.

ECAP(SERIAL | PARALLEL)

specifies whether to use the doors of enhanced CAPs serially or in parallel.

SERIAL

specifies that when ejecting through enhanced CAPs, LCM first fills one door and then the next door, alternating as necessary to perform the ejects scheduled for an LSM. This ensures that volumes are ejected in the order indicated by the LCM Eject Report. This is the default.

PARALLEL

specifies that when using enhanced CAPs, LCM uses both CAP doors to service ejects simultaneously, and schedules new eject batches as soon as a CAP door becomes available. Although LCM will schedule ejects in the same order indicated by the LCM Eject reports, some ejects may complete sooner than others.

TRUEVALUE

specifies the text to print for fields that have a Boolean value of TRUE.

text

specifies the text, which is a maximum of 20 characters. The default is "YES".

FALSEVALUE

specifies the text to print for fields that have a Boolean value of FALSE.

text

specifies the text, which is a maximum of 20 characters. The default is "NO".

SWAPPABLE | NONSWAPPABLE

specifies whether LCM is swappable when performing any planned actions on volumes. NONSWAPPABLE (the default) eliminates delays caused by LCM swapping in and out.

WKUNIT

specifies the DASD unit name to which LCM should dynamically allocate work data sets.

unit-name

the name of a generic or esoteric disk unit, which is a maximum of 8 characters, and cannot be enclosed in quotes. Ensure that the *unit-name* is a valid IBM-defined or installation-defined generic or esoteric disk unit. Do not code *unit-name* as the name of a virtual input/output (VIO) disk unit. For more information on generic and esoteric unit names, see the *JCL User's Guide* for your system.

The default value for *unit-name* is SYSALLDA.

LCM1314W | NOLCM1314W

If a value in a comparison contains a character that might indicate you meant to specify MATCHES, message LCM1314W is issued. For example, the following comparison generates message LCM1314W:

```
dsn eq 'sys2.backup.**'
```

The text of this message is:

LCM1314W This string is not considered a mask. If it is a mask, use the MATCHES condition. Specify OPTIONS NOLCM1314W to eliminate this warning.

LCM1314W is the default. NOLCM1314W suppresses message LCM1314W.

Usage

You can use the OPTIONS statement to define global LCM processing options. If you do not specify an OPTIONS statement in a parameter file, LCM uses default values for all OPTIONS statement parameters that have defaults. You can only specify one OPTIONS statement in a parameter file.

As described in the descriptions of the individual parameters, you can override OPTIONS global settings on other statements. For example, you can use the TMS statement to override this global setting NOEJBAD | EJBAD on the OPTIONS statement.

For more information about using LCM with your TMS, see [“General Guidelines for Defining TMSs”](#) on page 36.

Running LCM without a TMS

If you run LCM without a TMS, specify the `OPTIONS NOTMS` and `HSCONLY` parameters and do *not* specify any of the following statements or statement parameters:

- TMS
- DATASET
- LOCATION
- A METHOD statement COND parameter indicating CREATE, COPY, or GEN
- Any of the following OPTIONS statement parameters:
 - CYCLESOON
 - EJBAD
 - EXTERNAL
 - IGNORE18TRKFLAG
 - PICKSCR
 - SYNC
 - SYNCVTV
- REPORT DATASET
- A REPORT VOLUME statement field requiring TMS information
- A SUBPOOL statement TMSNAME parameter.
- SET METHOD statement conditions with fields that represent TMS information.

The LCM Eject File

An Eject File contains records describing all volumes selected for ejection by the LCM batch job that created the file. You cannot, however, use an Eject File as direct input to either the LCM Eject Utility or the HSC SLUADMIN Eject Cartridge Utility. Instead, you must use a program that you provide to process the Eject File (including filtering the volume list) to construct valid input records for the LCM Eject Utility or the HSC SLUADMIN Eject Cartridge Utility.

To create an Eject File, you:

- Specify the EJFILE keyword..
- Create a DD statement in the LCM batch job; for more information, see .

An eject file contains one record for each volume to be ejected. [TABLE 4-6](#) describes the Eject File record format.

TABLE 4-6 LCM Eject File Format

Starting Column	Ending Column	Field Description
1	6	Volser (left-justified and padded with trailing blanks if necessary.)
10	12	The LSM in which the volume resides (decimal 00-99)
16	23	Location name for cartridge (left-justified and padded with trailing blanks if necessary.)
27	31	Five-digit slot number padded with leading zeros or a blank field.
38	42	Five-digit volume sequence number padded with leading zeros; this field qualifies the volumes of a multiple volume data set (00000 denotes a scratch volume or an expired volume.)
46	51	Volser of first volume in a multi-volume data set (left justified and padded with trailing blanks when necessary), or blank when this volser is not available or for scratch volumes.
Note: All other columns must contain a blank character.		

FIGURE 4-7 shows an example of an LCM Eject File.

```
101385 00:00 Library 00101 00001 101385
103244 00:00 Library 00119 00001 103244
104857 00:00 Library 00212 00001 104857
FZV581 00:00 Local  00001 FZV581
100898 00:00 Vault 2 00040 00001 100898
1QQ557 00:00 Vault 2 00043 00001 1QQ557
1QZ526 00:00 Vault 2 00044 00001 1QZ526
100101 00:00 bVMS  00001100101
100106 00:00bVMS  00001100106
100439 00:00bLIB  00001100439
MM0689 00:01Library00078 00001MM0689
MM1318 00:01Library00415 00001 MM1318
100443 00:01Vault 2 0000900001 100443
100704 00:01Vault 2 0008200002 100443
100822 001 Vault 2 0008600003 100443
100373 001 Vault 2 0008300004 100443
AB6435 001 bLIB  00001 AB6435
AB6496 001 bLIB  00001 AB6496
```

FIGURE 4-7 Eject File Format

As shown in FIGURE 4-7, Eject File records are written in ascending order by LSM id.

Note – In the example above, location names bLIB and bVMS each begin with a blank character: the blank is part of these location names.

Examples

FIGURE 4-8 shows the defaults for the OPTIONS statement.

```
Options
Ecap(Serial)           // Fill each Ecap door separately
Ejmode(Closest)       // Default Eject Mode
Ejmult(1)              // Default Eject Multiple
Enterprompt            // Operator WTOR for enters
External(NeverEject Default) // Marked external in TMS
HSConly(NeverEject)   // If tape in HSC CDS only
Minenter(2)           // Days since entered
Minref(2)              // Days since referenced
NoEjbad                // Do not eject tapes marked Bad
NoPause                // Start ejects without pause
Pickej                 // Eject Volumes for Need
Pickflex(10)           // Pick flexibility percentage
NoPickscr              // Don't pick scratch volsers
NonSwappable           // Not swappable during ejects
Sync                   // Sync scratch status
Wkunit(SYSALLDA)      // DASD name for work datasets
;
```

FIGURE 4-8 OPTIONS Statement Defaults

To change some of the defaults, create an OPTIONS statement that specifies the changes only. The rest of the values are the defaults. For example, create the OPTIONS statement shown in FIGURE 4-9 or FIGURE 4-10 to change only selected values.

```
Options
Check                  // Execute in CHECK mod
Ecap(Parallel) // Fill each Ecap door in parallel
Pause                  // Pause before starting ejects
NoSync // Do not Sync scratch status
;
```

FIGURE 4-9 OPTIONS Statement to Change Selected Values (Nearline Volumes)

```
Options
Sync                   // Sync scratch status
SyncVTV // Sync scratch status (virtual volumes)
;
```

FIGURE 4-10 OPTIONS Statement to Change Selected Values (Nearline Volumes and VTVs)

PULLLIST

The PULLLIST statement specifies a list of volumes that an operator must enter for an upcoming production run.

Syntax

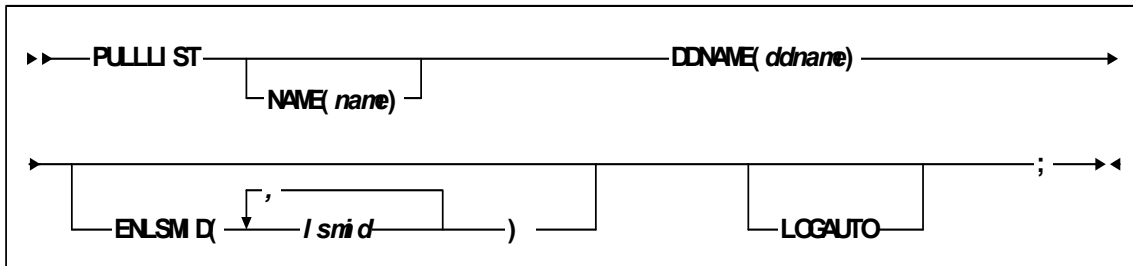

FIGURE 4-11 PULLLIST Statement Syntax

Parameters

TABLE 4-7 lists the valid abbreviations for the PULLLIST statement.

TABLE 4-7 PULLLIST Statement Abbreviations

Statement or Parameter	Abbreviation
PULLLIST	PULLLIST,PLST
ENLSMID	ENLSM

NAME

specifies the pull list name, which can be referenced by other statements in the LCM parameter file.

pulllist

the pull list name.

The default pull list name is PULLLIST followed by the number of the PULLLIST statement. For example, the default for the first PULLLIST statement is PULLLIST1.

DDNAME

specifies the ddname of the file that contains the pull list.

ddname

specifies the ddname of the JCL DD statement that is allocated to the sequential file containing the pull list. The default value for ddname is LCMPULL.

ENLSMID

specifies the LSMs that will provide cells to enter the volumes on the pull list. LCM ensures that the required number of free cells are available. The default ENLSMID list for a specific PULLLIST statement includes all LSMs at the top of the LSM group hierarchy or hierarchies for all ACSs being managed.

lsmid

a hexadecimal LSM ID (x' 00:00' to x'FF:7F').

LOGINLSM

specifies that LCM writes an informational message to the log for each nonscratch volume on a pull list already in an LSM (managed or unmanaged).

Note – LOGINLSM is synonym for LOGAUTO, which is designed to replace LOGINLSM.

LOGAUTO

specifies that LCM writes an informational message to the log for each nonscratch volume on a pull list already in automated tape storage, which includes physical volumes in an LSM and VTVs in a VTSS.

Usage

Use the following guidelines to create PULLLIST statements:

- You can specify an unlimited number of PULLLIST statements in a parameter file. LCM checks multiple statements in their order in a parameter file for volume information.
- If a volume is defined in multiple pull lists, it will be associated with the first pull list that defines it. Subsequent occurrences of the volume in the same pull list or in other pull lists are ignored and a message is issued to the log for each occurrence.
- Pull lists can contain only nonscratch volumes (not scratch volumes or cleaning cartridges).
- If a volume on a pull list is already in a managed LSM, LCM issues an informational message if you specified the PULLLIST LOGINLSM parameter. LCM will not eject these volumes but can demote them.
- Volumes on a pull list take precedence over free cell and scratch criteria when determining how to manage an LSM. All free cells available are used to enter the volumes on the pull list.
- Volumes on a pull list are distributed between the LSMs on the ENLSMID parameter (or the default list if ENLSMID is not specified) in an even spread while filling up each CAP. For example, if the following scenario applies: LSM 00:00, cap size 80; LSM 001, cap size 21; 100 valid volumes on Pull List. LSM 00:00 would have 80 on the enter list and LSM 00:01 would have 20 on the enter list.

If you have specified ENLSMIDs from multiple ACSs, it is possible to separate multi-volume data sets between ACSs. Volumes are sorted by Location Code, Slot, Serial number order and placed in LSMs in the same order specified on the ENLSMID parameter.

- VTVs can be included on pull lists, which is useful if you want to pre-stage VTVs for a specific job or batch processing window.

SET METHOD

The SET METHOD statement conditionally assigns management methods to unexpired nonscratch volumes and nonscratch volumes managed by the NOEXPIRECHECK keyword.

Syntax

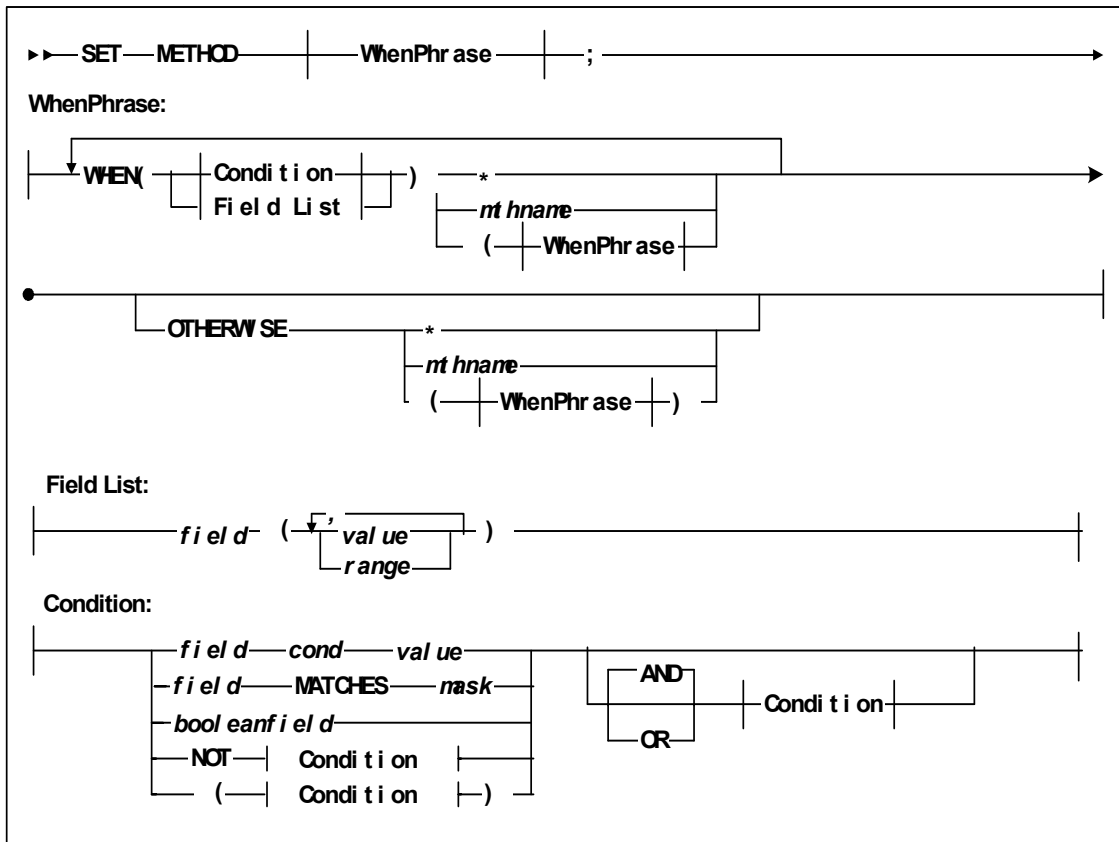

FIGURE 4-12 SET METHOD Statement Syntax

Parameters

TABLE 4-8 lists the valid abbreviations for the SET METHOD statement.

TABLE 4-8 SET METHOD Statement Abbreviations

Statement or Parameter	Abbreviation
METHOD	MTH
EQ	=
GE	>=
GT	>
LE	<=
LT	<
NE	≠
NOT	¬
AND	&
OR	

WHEN(*condition*)

begins a WHEN phrase followed by a field list or condition and method that applies to the volumes that meet the condition.

You can specify an unlimited number of WHEN phrases; the minimum is one. ExLM selects the first condition that covers a volume.

You can specify a WHEN condition that specifies * instead of *mtlname* to exclude some volumes from processing by the SET METHOD statement

Field List

specifies the fields to use for volume selection. For a volume to be selected, the value for each *field* must match at least one of the provided *values* or *ranges*.

The valid *values* depend on the type of *field* as described in TABLE 4-9.

TABLE 4-9 Valid Types of Fields

Type	Values and Examples
Boolean	Specify TRUE or FALSE. FALSE is less than TRUE in comparisons.
Character	Specify a string in single quotes. For example: 'string'

TABLE 4-9 Valid Types of Fields

Type	Values and Examples
Date	Specify a date constant or MISSING. Date constants are of the form 'date'D or 'date'd where date can be specified in any date format defined in the "SET METHOD Statement WHEN Fields" section of <i>LCM Quick Reference</i> except TEXTDAYDATE. You must follow the format exactly. For example: '05Sep93'd is valid but '5Sep93'd is not.
Integer	Specify a number or MISSING. For example: 123
Time	Specify a time constant or MISSING. Time constants are of the form 'time'T where time can be specified in any time format defined in the "SET METHOD Statement WHEN Fields" section of <i>LCM Quick Reference</i> . You must follow the format exactly. For example: '12:30't is valid but '12;30't is not.

MISSING can also be specified as a period ("."). MISSING is less than all other values.

TABLE 4-10 Valid Formats for Date Fields

Type	Size	Example
yyddd	5	97248
ccyyddd	7	1997248
yy.ddd	6	97.248
ccyy.ddd	8	1997.248
mm/dd/yy	8	09/05/97
mm/dd/ccyy	10	09/05/1997
yy-mm-dd	8	93-09-05
yyyy-mm-dd	10	2000-09-05 This is the default.
dd_mmm_yy	9	09 Sep 98
dd_mmm_ccyy	11	09 Sep 2000
ddmmmyy	7	09Sep98
ddmmmcyy	9	09Sep1997
textdate	18	September 9, 2000
textdaydate	29	Wednesday, September 10, 2000

TABLE 4-11 Valid Formats for Time Fields

Type	Size	Example
hh:mm	5	22:21 This is the default.
hh:mm:ss	8	22:21:32
hh:mm:ss_pm	11	10:21:32 PM

Condition

specifies a condition for volume selection.

field cond value

specifies a field, a condition, and a value to compare with one of the following conditions:

EQ

equal to.

NE

not equal to.

GE

greater than or equal to.

GT

greater than.

LE

less than or equal to.

LT

less than.

For example, `VOLSER GE A00243` selects volsers greater than or equal to A00243.

field MATCHES mask

specifies a field and a mask for selection. The valid masks depend on the field selected:

- `DATASETNAME`, `BASENAME`: Specify a string in single quotes. Wildcards can be used as follows:

`"**"` matches one or more data set qualifiers.

`"*"` matches one or more characters within a qualifier.

`"%"` matches one character within a qualifier.

- Other character fields: Specify a string in single quotes. Wildcards can be used as follows:

`"*"` matches one or more characters.

`"%"` matches one character.

For example, `DataSetName MATCHES DR*` selects all data sets with HLQs beginning with DR.

booleanfield

specifies a Boolean field to be tested for TRUE. Specify NOT before the field if you want to test for FALSE.

For example, `CLN` selects volumes that are cleaning cartridges.

NOT

reverses the condition that immediately follows the NOT keyword.

For example, `NOT CLN` selects volumes that are **not** cleaning cartridges.

AND

make the selection if both conditions are true.

For example, `NOT CLN AND VOLSER(A00500-A00750)` selects volumes A00500 through A00750 that are **not** cleaning cartridges.

OR

make the selection if either condition is true. For example, NOT CLN OR VOLSER(A00500-A00750) selects volumes A00500 through A00750 **or** volumes that are not cleaning cartridges.

*

do not assign a method to volumes covered by this WHEN condition.

methname

assign the specified method to volumes covered by this WHEN condition.

OTHERWISE

selects all eligible volumes not selected by the WHEN conditions and optionally assigns a management method to them.

*

do not assign a method to volumes covered by the OTHERWISE condition.

methname

assign the specified method to volumes covered by the OTHERWISE condition.

Note – For complete information on the fields available, their types, values, and use, see *LCM Quick Reference*.

Usage

Use the SET METHOD statement to conditionally assign management methods to unexpired nonscratch volumes and nonscratch volumes managed by the NOEXPIRECHECK keyword. The SET METHOD statement is valid for any volume in a managed LSM that is not being ignored or managed as a scratch or cleaning cartridge.

For more information about specifying global options and methods, see [“OPTIONS” on page 114](#) and [“METHOD” on page 106](#).

Note – If no statement assigns a method to a volume, LCM will assign a default method to the volume. The default method for Multiple Volume Cartridges (MVCs) is MVC. The default method for all other volumes is STANDARD.

Examples

The most commonly used form of a condition compares one volume *field* with a *value*. For example, to select only volumes with a generation number higher than 4, specify the following:

```
WHEN(GENERATION GT 4)
```

All other volumes (non-gdgs and gdgs with a generation lower than or equal to 4) will not be selected for processing.

You can also use the AND keyword to select only volumes that are both in subpool TEST and have generation numbers greater than 4:

```
WHEN(SUBPOOL EQ 'TEST' AND GENERATION GT 4)
```

AND keywords are processed before OR keywords. For example, the following condition specifies that for a volume to be selected, it must either be in subpool TEST1 or it must be both in subpool TEST2 and have a generation number greater than 4:

```
WHEN(SUBPOOL EQ 'TEST1' OR SUBPOOL EQ 'TEST2' AND  
GENERATION GT 4)
```

In general, the AND keyword is used to reduce the set of volumes selected and the OR keyword is used to expand the set of volumes selected.

You can also use Boolean fields to reduce the set of volumes selected. For example:

```
WHEN(GDG AND JOBNAME MATCHES 'PROD0')
```

is equal to:

```
WHEN(GDG EQ TRUE AND JOBNAME MATCHES 'PROD0')
```

You can use the SET METHOD statement to replace predefined methods. For example, [FIGURE 4-13](#) shows a SET METHOD statement to replace the STANDARD predefined method.

```
set method  
when(method='STANDARD') /* Use method AgeMedium for volumes */  
AgeMedium; /* that would otherwise have been */
```

FIGURE 4-13 SET METHOD Example: Replacing a Predefined Management Method

SET METHOD Statement WHEN Fields

For more information, see the “SET METHOD Statement WHEN Fields” section of *LCM Quick Reference*.

SUBPOOL

The SUBPOOL statement defines a volume subpool that you can use to qualify scratch criteria specified on the MANAGE PHYSICAL statement. The SUBPOOL statement can also specify the TMS that manages the volumes in the subpool (or IGNORE for TMS-managed volumes not available to LCM). You can also use the SUBPOOL statement to specify a management method for nonscratch volumes in the subpool.

Syntax

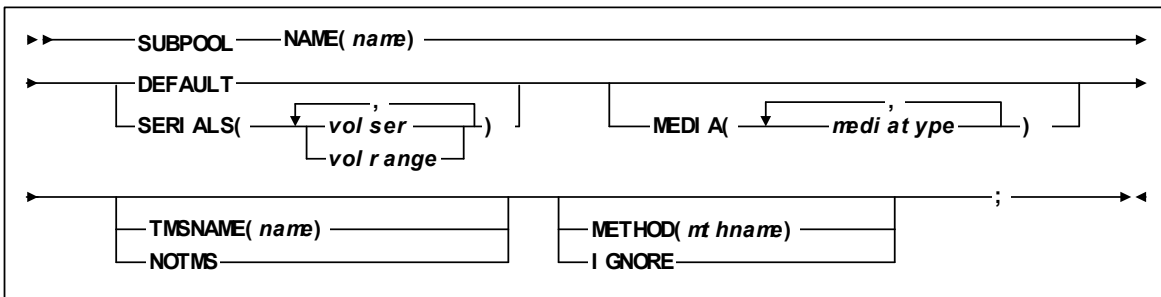

FIGURE 4-14 SUBPOOL Statement Syntax

Parameters

TABLE 4-12 lists the valid abbreviations for the SUBPOOL statement.

TABLE 4-12 SUBPOOL Statement Abbreviations

Statement or Parameter	Abbreviation
SUBPOOL	SP
NAME	SPNAME
SERIALS	RANGE
METHOD	MTH
STANDARD	S, ST, STA, STAN, CST MEDIA1, STD, 1, 3480
LONG	L, LO, LON, ECART, E, ECCST, ETAPE, MEDIA2, 3490E
DD3A	A
DD3B	B
DD3C	C
ZCART	Z

NAME

specifies the name of the tape subpool, which is a maximum of 16 characters. Do not specify GENERAL, which is the reserved name of the default subpool. You can, however, specify a different name for the default subpool. Do not specify the same subpool name for more than one SUBPOOL statement in the same parameter file.

subpool
the name of the tape subpool.

DEFAULT

specifies this subpool is the default subpool, which covers all volumes that are not covered by another SUBPOOL statement. You can only specify one default subpool. If you do not define a default subpool, LCM automatically defines one with the name GENERAL.

The DEFAULT and SERIALS keywords are mutually exclusive.

SERIALS

specifies the volsers for the volumes in the tape subpool.

The DEFAULT and SERIALS keywords are mutually exclusive.

volsers
a single volsers.
volrange
a range of consecutive volsers.

Use one or more blanks to separate the elements in a list of *volsers* or *volranges*. You can specify *volsers* and *volranges* in any order.

Any number of volumes can be covered by SUBPOOL statements. However, the total number of *volser* and *volrange* elements is a maximum of 1000 for all SUBPOOL statement, combined.

Do not specify:

- The same *volser* or *volrange* more than once for the same SUBPOOL statement or for more than one SUBPOOL statement in the same parameter file.
- Overlapping *volranges* or a *volser* that overlaps with a *volrange*.

MEDIA

Specifies one or more of the media types managed as separate tape groups within the subpool:

STANDARD

Standard length 3480 cartridge. It can be used on any 4480 or 4490 transport. If written in 36 track mode on a 4490 transport, the data cannot be read by a 18 track 4480 transport.

LONG

3490E enhanced capacity (ECART) cartridge. It can be used only on 36 track transports (4490 or 9490) and can be visually identified by the two tone colored case.

DD3A

10 Gb capacity helical cartridge.

DD3B

25 Gb capacity helical cartridge.

DD3C

50 Gb capacity helical cartridge.

VIRTUAL

virtual tape volumes (VTVs) created by VSM.

STK1R

250 Gb capacity 9840 cartridge.

STK2

any 9940 cartridge.

STK2P

60 Gb capacity 9940 cartridge.

ZCART

3490EE cartridge (ZCART), which can only be used in a 9490EE transport.

LTO-1.5T LTO 1.5 TB data cartridge

LTO-1.5W

LTO 1.5 TB worm cartridge

LTO-2.5T

LTO 2.5 TB data cartridge

LTO-2.5W

LTO 2.5 TB worm cartridge

T10000T2

T10KC data cartridge
T1000TT
T10KC sport (short) cartridge
T1000CC
T10KC Cleaning cartridge
T1000CL
T10KA/B/C Cleaning cartridge

If you do not specify **MEDIA**, LCM does not manage the subpool by media type, and creates one tape group that includes all volumes in the subpool. The name of the single tape group is the same as the name of the subpool. For example, the subpool statement

SUBPOOL NAME(A) SERIALS(000000-999999);

creates only tape group **A**, which is a tape group including all volumes in subpool **A**.

If you specify **MEDIA**, LCM creates one tape group for each of the specified media types. The name of each such tape group is the name of the subpool followed by an underscore and the name of the media type. LCM creates the **subpool_OTHER** tape group for all volumes in the subpool that do not have one of the specified media types.

You can specify these tape groups on the **MANAGE PHYSICAL** statement when qualifying scratch criteria. These tape groups will also appear in the standard scratch and nonscratch volume reports.

TMSNAME

specifies the name of the TMS that contains information for volumes in this subpool.

tmsname

the TMS name as specified on the **TMS NAME** parameter for the TMS.

NOTMS

do not use TMS information for the subpool because the TMS information is not valid.

METHOD

the method to manage nonscratch volumes covered by this **SUBPOOL** statement. The specified method applies if no previous statement in the parameter file covers the same volume and specifies a method. This method can be overridden by the **EXTERNAL**, **HSCONLY**, and **METHODFILE** options of the **OPTIONS** statement and the **SET METHOD** statement and may be influenced by the **OPTIONS** statement **CYCLESOON**, **MINENTER**, and **MINREF** options. For more information, see "OPTIONS" on page 114 and "METHOD" on page 106.

Note – If no statement assigns a method to a volume, LCM will assign a default method to the volume. The default method for Multiple MVCs is **MVC**. The default method for all other volumes is **STANDARD**.

IGNORE

ignore TMS information for all volumes in the subpool, assign them a method of **NEVEREJECT**, do not do scratch synchronization, and report scratch status per the HSC CDS. LCM generates reports for these volumes. **LOCATION** statements,

DATASET statements, SET METHOD statements, and method file entries do not affect volumes in volumes in subpools defined with a NOTMS or IGNORE keyword. You can use this parameter for volumes controlled by TMSs not defined to LCM.

Usage

Use the following guidelines to define subpools:

- You can specify a maximum of 255 SUBPOOL statements in a parameter file.
- Volumes not covered by a SUBPOOL statement are assigned to either the automatically created GENERAL default subpool or the name of a default subpool that you specify.
- All SUBPOOL statements in a parameter file must precede the first MANAGE PHYSICAL statement in the same file.
- The total number of *volser* and *volrange* elements for all SUBPOOL statements combined cannot exceed 1000.
- The keyword used to specify media type will be used to form a tape group name. The length of the tape group name cannot exceed 25 characters. Therefore, the combined length of the subpool name, the media type keyword, and the underscore cannot exceed 25 characters.
- LCM uses the HSC VOLATTR statements in effect to identify the media type of a volume. To access to the VOLATTR statements currently in effect, LCM requires the HSC programmatic interface function QDSN. See the *LCM Installation Guide* for information about the required HSC software levels.
- StorageTek recommends that the HSC programmatic interface function QDSN be available and that all VOLATTR statements be identical on all hosts. If a volume does not have a media type defined by the HSC and is not covered by any HSC VOLATTR statements (or the QDSN function is not available), LCM does not assign a media type to the volume.
- If a SUBPOOL statement covers cleaning cartridges, or specifies a name of CLEANING, cleaning cartridge management is disabled. LCM issues an informational message and the keywords BALCLN and NUMCLN are not valid on any MANAGE PHYSICAL statement.
- You cannot specify tape groups created for VTVs for scratch criteria on the MANAGE PHYSICAL statement.

For more information about using tape subpools with your TMS, see [“Using LCM with Your TMS” on page 35](#)

■

Examples

Volsers Only

FIGURE 4-15 shows an example of an SUBPOOL statement that defines a subpool by volsers only.

```
set method
when(method='STANDARD') /* Use method AgeMedium for volumes */
AgeMedium; /* that would otherwise have been */
```

FIGURE 4-15 SUBPOOL Statement: Define Subpool by Volsers Only

Volsers and Media Type

FIGURE 4-16 shows an example of an SUBPOOL statement that defines a subpool by volsers and media types.

```
Subpool
Name(Atape)           // Subpool Name
Serials(A00000-A99999) // Serial number ranges
Media(Long STK1R)// Media types for this subpool
;                      // End of Subpool statement
```

FIGURE 4-16 SUBPOOL Statement: Define Subpool by Volsers and Media Types

Ignore Subpool

FIGURE 4-17 shows an example of an SUBPOOL statement that specifies that LCM ignores the defined subpool.

```
Subpool
Name(Atape)           // Subpool Name
Serials(A00000-A99999) // Serial number ranges
Ignore // Ignore TMS and take no actions
Media(Long STK1R)// Media types for this subpool
;                      // End of Subpool statement
```

FIGURE 4-17 SUBPOOL Statement: Ignore Defined Subpool

Note – To set ignore on in LCM Explorer, click on the **No Tape Management System** option and the **Do Not Take Actions** option below it.

Assign Method NEVEREJECT to Subpool

FIGURE 4-18 shows an example of a SUBPOOL statement that assigns method NEVEREJECT to a subpool.

```
Subpool
Name(Atape)           // Subpool Name
Serials(A00000-A99999) // Serial number ranges
Media(Long STK1R)// Media types for this subpool
Method(NeverEject)    // Do not eject nonscratch volumes
;                     // End of Subpool statement
```

FIGURE 4-18 SUBPOOL Statement: Assign Method NEVEREJECT

Unconditionally Assign Method NEVEREJECT to Subpool

FIGURE 4-19 shows an example of a parameter file that unconditionally assigns method NEVEREJECT to a subpool.

```
Subpool
Name(Atape)           // Subpool Name
Serials(A00000-A99999) // Serial number ranges
Media(Long STK1R)// Media types for this subpool
;                     // End of Subpool statement
Set Method// Unconditionally assign method NeverEject
// to Atape nonscratch volumes.
When(                 // Start When condition
( Subpool EQ 'Atape') // Subpool Equals 'Atape'
)                     // End When Condition
NeverEject           // Method if condition met
;                     // End of Set Method statement
```

FIGURE 4-19 SUBPOOL Statement: Unconditionally Assign Method NEVEREJECT

Note – You can use the SET METHOD statement to separate the assignment of a method from the subpool definition. For example, SUBPOOL statements in an LCM Explorer configuration file are used by multiple runs. You can use the **Advanced** tab in Explorer to unconditionally assign methods.

TMS CA1

The TMS CA1 statement defines CA-1 to LCM and selects processing options for CA-1.

Syntax

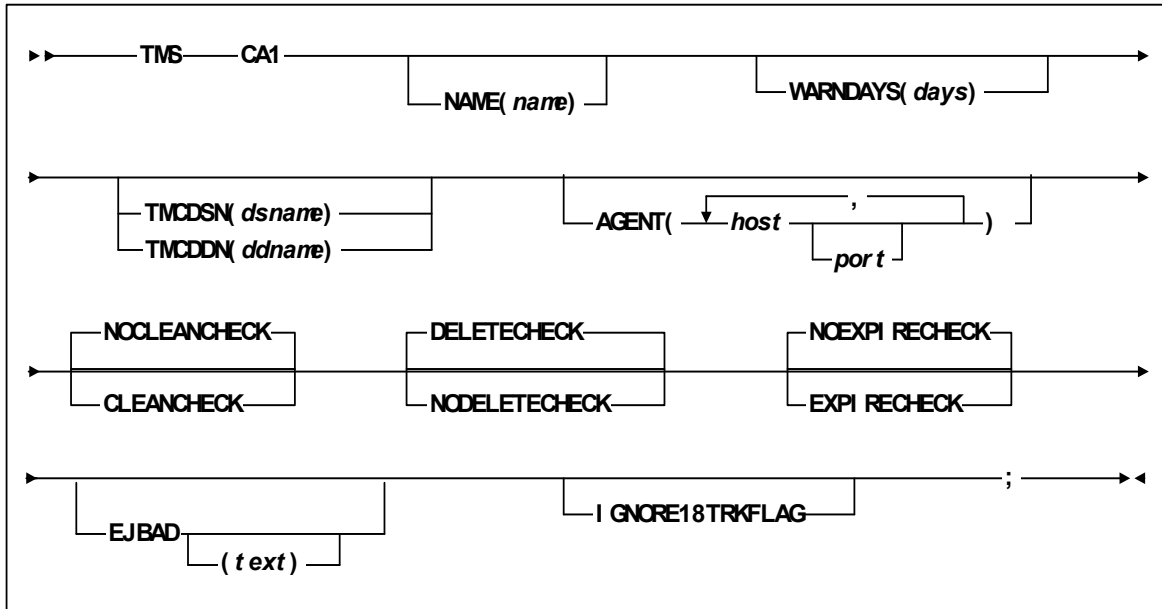

FIGURE 4-20 TMS CA1 Statement Syntax

Parameters

TABLE 4-13 lists the valid abbreviations for the TMS CA1 statement.

TABLE 4-13 TMS CA1 Statement Abbreviations

Statement or Parameter	Abbreviation
NAME	TMSNAME
NOEXPIRECHECK	NOEXPCHK
EXPIRECHECK	EXPCHK
NOCLEANCHECK	NOCLNCHK
CLEANCHECK	CLNCHK

NAME

specifies the name for this TMS. Other statements (for example, SUBPOOL) can refer to this TMS name.

tmsname

the TMS name. You can specify a maximum of 10 characters. The default TMS name is 'TMS' followed by the number of the TMS statement.

TMCDNS

specifies the DSname of the CA-1 tape management catalog (TMC).

You can specify TMCDNS or TMCDD but not both. If you specify AGENT, you must also specify TMCDNS.

dsname

the DSname of the CA-1 TMC.

TMCDN

specifies the ddname of the CA-1 TMS catalog.

You can specify TMCDN or TMCDNS but not both.

ddname

The ddname of the JCL DD statement for the CA-1 TMC. The default is LCMTMSDB.

AGENT

specifies that LCM accesses information for the specified TMS from an LCM Agent running on the specified host using the specified port.

If you specify AGENT, you must also specify TMCDNS.

host

specifies the host where LCM Agent is running. You can specify an IP address or a host name.

port

specifies the port number of the LCM Agent. If *port* is not specified, the default is 3002.

NOCLEANCHECK | CLEANCHECK

specifies whether LCM should treat scratch volumes that have the TMCLEAN flag on as defective.

The TMBADTAP flag also causes LCM to treat a volume as defective even if this parameter is not specified. When this parameter is in effect, the TMBADTAP flag in the TMS is the only source of information used in classifying a volume as defective.

NODELETECHECK | DELETECHECK

specifies whether LCM discards information for volumes marked “in delete status” in the TMS. When you specify NODELETECHECK, ExLM retains residual volume information for all volumes, including those marked “in delete status”.

This residual information consists of data set, reference date, creation date, job name, and so forth.

DELETECHECK specifies that ExLM discards information for volumes marked “in delete status” in the TMS.

NOEXPIRECHECK | EXPIRECHECK

specifies whether LCM ignores expiration information in the TMS and treats the volume as a nonscratch volume. When you specify NOEXPIRECHECK, you can use the residual data in the TMS catalog that contains the data set name and location code of the volume.

EXPIRECHECK specifies that ExLM should treat volumes that are marked expired in the TMS as expired volumes. ExLM treats expired volumes as CYCLESOON volumes; for more information, see [“CYCLESOON” on page 121](#).

NOEJBAD | EJBAD

specifies whether LCM ejects all scratch volumes marked defective by the TMS. The default is to not eject defective volumes (NOEJBAD).

You can also specify this parameter for all TMSs on the OPTIONS statement.

text

specifies the text of message SLS1251E that appears when the CAP door is unlocked to eject defective volumes. The text is a maximum of 32 characters. Enclose the text in single quotes if it contains blanks or other special characters.

IGNORE18TRKFLAG

specifies that LCM treats all volumes in the TMS as cartridge tapes (not reel tapes).

If you specify PICKSCR but not IGNORE18TRKFLAG, ExLM selects only non-LSM scratch volumes that are marked as cartridge tapes in the TMS for entry into an LSM.

Note – You can also specify this parameter for all TMSs on the OPTIONS statement.

Usage

For more information, see [“Using LCM with CA-1” on page 38](#).

TMS COMMON

The TMS COMMON statement defines and selects processing options for a TMS that uses the LCM Common TMS interface.

Syntax

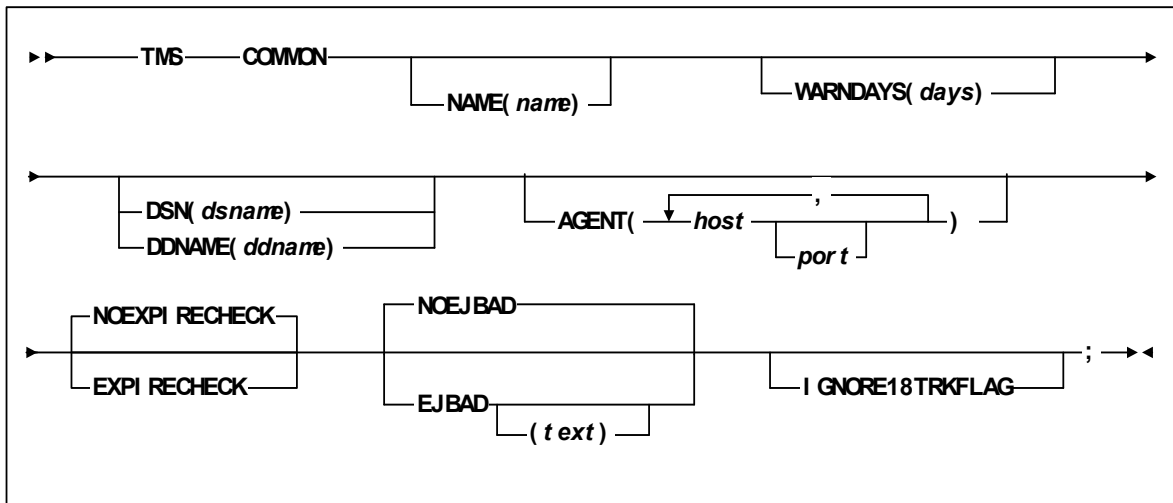

FIGURE 4-21 TMS COMMON Statement Syntax

Parameters

TABLE 4-14 lists the valid abbreviations for the TMS COMMON statement.

TABLE 4-14 TMS COMMON Statement Abbreviations

Statement or Parameter	Abbreviation
NAME	TMSNAME
NOEXPIRECHECK	NOEXPCHK
EXPIRECHECK	EXPCHK

NAME

specifies the name for this TMS. Other statements (for example, SUBPOOL) can refer to this TMS name.

tmsname

the TMS name. You can specify a maximum of 10 characters. The default TMS name is 'TMS' followed by the number of the TMS statement.

WARNDAYS

specifies that LCM issues warning message LCM0324W if no volumes in the TMS have been referenced within the specified days. This parameter helps you detect an inactive TMS.

1| *days*

the days within which no volumes in the TMS have been referenced. LCM uses the most recent volume reference day (DaysSinceReferenceTMS) for comparison. Valid values are 0 to 9999 and the default is 1. Specify a value of 0 if you do not want LCM to perform this check.

DSN

specifies the DSname of the Common Interface TMS's tape management catalog (TMC).

You can specify DSN or DDNAME but not both. If you specify AGENT, you must also specify DSN.

dsname

the DSname of the TMS catalog. The file referenced by *dsname* must be a sequential file containing variable length records. Each record in the file provides TMS information about one volume.

DDNAME

specifies the ddname of the TMS catalog.

You can specify DDNAME or DSN but not both.

ddname

The ddname of the JCL DD statement for the Common Interface's TMS catalog. The file referenced by *ddname* must be a sequential file containing variable length records. Each record in the file provides TMS information about one volume. The default is LCMTMSDB.

AGENT

specifies that LCM accesses information for the specified TMS from an LCM Agent running on the specified host using the specified port.

If you specify `AGENT`, you must also specify `DSN`.

host

specifies the host where LCM Agent is running. You can specify an IP address or a host name.

port

specifies the port number of the LCM Agent. If *port* is not specified, the default is 3002.

NOEXPIRECHECK | EXPIRECHECK

specifies whether LCM ignores expiration information in the TMS and treats the volume as a nonscratch volume. When you specify `NOEXPIRECHECK`, you can use the residual data in the TMS catalog that contains the data set name and location code of the volume.

`EXPIRECHECK` specifies that ExLM should treat volumes that are marked expired in the TMS as expired volumes. ExLM treats expired volumes as `CYCLESOON` volumes; for more information, see [“CYCLESOON” on page 121](#).

NOEJBAD | EJBAD

specifies whether LCM ejects all scratch volumes marked defective by the TMS. The default is to not eject defective volumes (`NOEJBAD`).

You can also specify this parameter for all TMSs on the `OPTIONS` statement.

text

specifies the text of message `SLS1251E` that appears when the CAP door is unlocked to eject defective volumes. The text is a maximum of 32 characters. Enclose the text in single quotes if it contains blanks or other special characters.

IGNORE18TRKFLAG

specifies that LCM treats all volumes in the TMS as cartridge tapes (not reel tapes).

If you specify `PICKSCR` but not `IGNORE18TRKFLAG`, ExLM selects only non-LSM scratch volumes that are marked as cartridge tapes in the TMS for entry into an LSM.

Note – You can also specify this parameter for all TMSs on the `OPTIONS` statement.

Usage

The TMS COMMON statement defines and selects processing options for a TMS that uses the LCM Common TMS interface. An installation written or vendor supplied program must be used to create a sequential file containing TMCI records. For more information, see [“TMCI Record” on page 402](#).

Note – Although LCM supports using the Common TMS Interface through an LCM Agent, this may not be a practical solution. Because Common TMS Interface requires that an installation or vendor supplied program generate the file for input, this file must be created on the agent host before running LCM. It is your responsibility to insure that these files are created in advance and kept up-to-date for use by the LCM Agent.

TMS CTT

The TMS CTT statement defines Control-T to LCM and selects processing options for Control-T.

Syntax

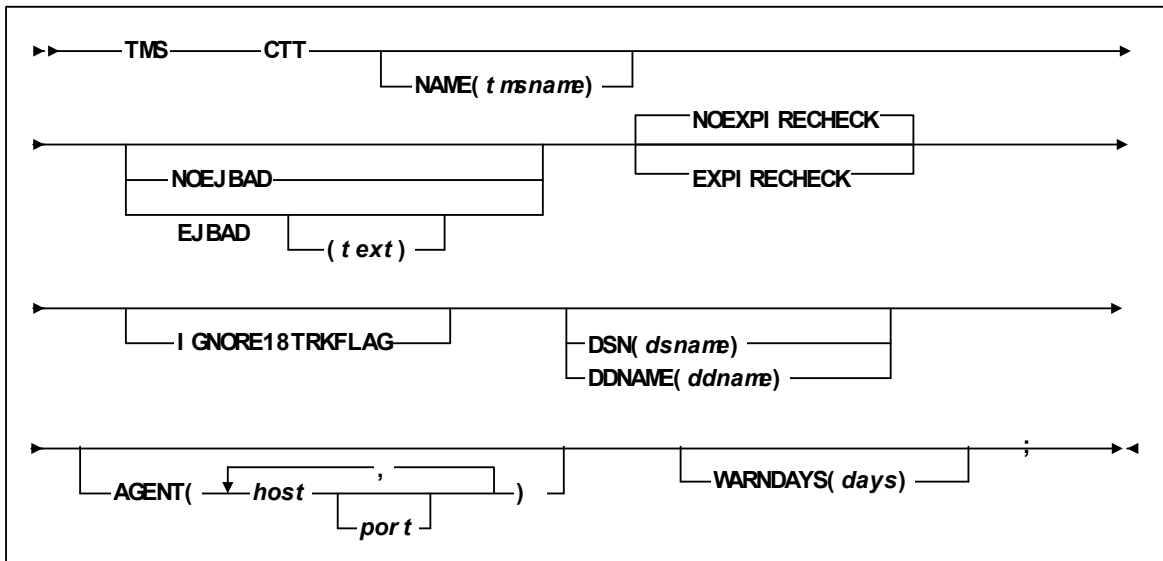

FIGURE 4-22 TMS CTT Statement Syntax

Parameters

TABLE 4-15 lists the valid abbreviations for the TMS CTT statement.

TABLE 4-15 TMS CTT Statement Abbreviations

Statement or Parameter	Abbreviation
NAME	TMSNAME
NOEXPIRECHECK	NOEXPCHK
EXPIRECHECK	EXPCHK

NAME

specifies the name for this TMS. Other statements (for example, SUBPOOL) can refer to this TMS name.

tmsname

the TMS name. You can specify a maximum of 10 characters. The default TMS name is 'TMS' followed by the number of the TMS statement.

NOEJBAD | EJBAD

specifies whether LCM ejects all scratch volumes marked defective by the TMS. The default is to not eject defective volumes (NOEJBAD).

You can also specify this parameter for all TMSs on the OPTIONS statement.

text

specifies the text of message SLS1251E that appears when the CAP door is unlocked to eject defective volumes. The text is a maximum of 32 characters. Enclose the text in single quotes if it contains blanks or other special characters.

NOEXPIRECHECK | EXPIRECHECK

specifies whether LCM ignores expiration information in the TMS and treats the volume as a nonscratch volume. When you specify NOEXPIRECHECK, you can use the residual data in the TMS catalog that contains the data set name and location code of the volume.

EXPIRECHECK specifies that ExLM should treat volumes that are marked expired in the TMS as expired volumes. ExLM treats expired volumes as CYCLESOON volumes; for more information, see ["CYCLESOON" on page 121](#).

IGNORE18TRKFLAG

specifies that LCM treats all volumes in the TMS as cartridge tapes (not reel tapes).

If you specify PICKSCR but not IGNORE18TRKFLAG, ExLM selects only non-LSM scratch volumes that are marked as cartridge tapes in the TMS for entry into an LSM.

Note – You can also specify this parameter for all TMSs on the OPTIONS statement.

DSN

specifies the DSname of the Control-T TMS tape catalog.

You can specify DSN or DDNAME but not both. If you specify AGENT, you must also specify DSN.

dsname

the DSname of the TMS catalog. The file referenced by *dsname* must be a sequential file containing variable length records. Each record in the file provides TMS information about one volume.

DDNAME

specifies the ddname of the Custom Interface's TMS catalog.

You can specify DDNAME or DSN but not both.

ddname

The ddname of the JCL DD statement for the TMS catalog. The file referenced by *ddname* must be a sequential file containing variable length records. Each record in the file provides TMS information about one volume. The default is LCMTMSDB. For more information, see ["Using LCM with a Custom TMS Interface Module" on page 67](#).

AGENT

specifies that LCM accesses information for the specified TMS from an LCM Agent running on the specified host using the specified port.

If you specify AGENT, you must also specify DSN.

host

specifies the host where LCM Agent is running. You can specify an IP address or a host name.

port

specifies the port number of the LCM Agent. If *port* is not specified, the default is 3002.

WARNDAYS

specifies that LCM issues warning message LCM0324W if no volumes in the TMS have been referenced within the specified days. This parameter helps you detect an inactive TMS.

1| *days*

the days within which no volumes in the TMS have been referenced. LCM uses the most recent volume reference day (DaysSinceReferenceTMS) for comparison. Valid values are 0 to 9999 and the default is 1. Specify a value of 0 if you do not want LCM to perform this check.

Usage

For more information, see ["Using LCM with Control-T" on page 66](#).

TMS CUSTOM

The TMS CUSTOM statement defines and selects processing options for a TMS that uses the LCM Custom TMS interface. For more information, see [“Using LCM with a Custom TMS Interface Module”](#) on page 67.

Syntax

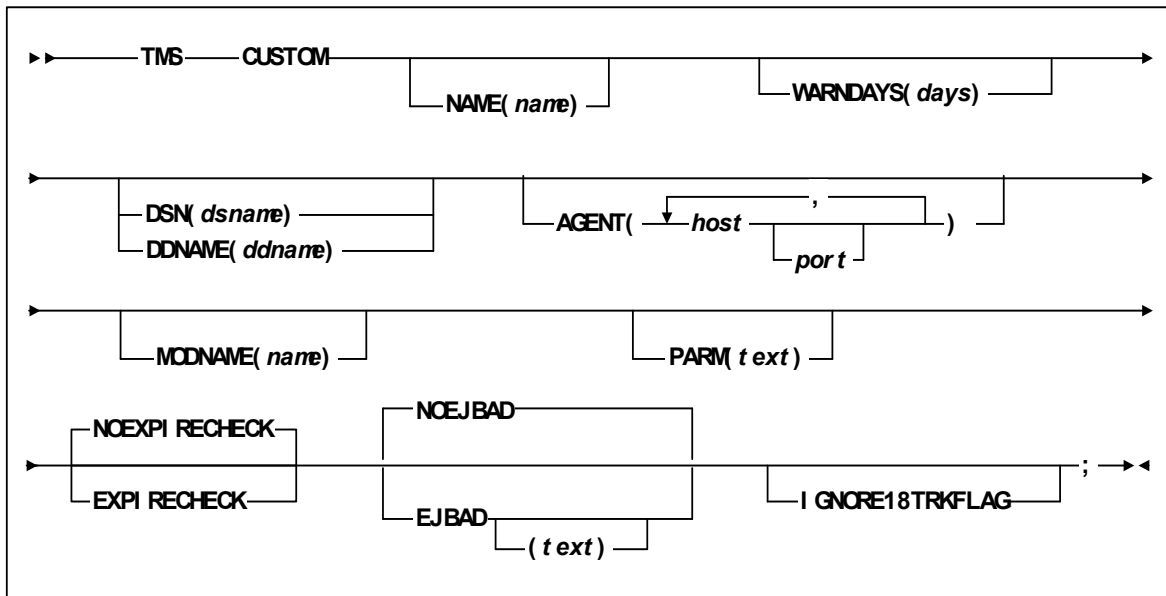

FIGURE 4-23 TMS CUSTOM Statement Syntax

Parameters

TABLE 4-16 lists the valid abbreviations for the TMS CUSTOM statement.

TABLE 4-16 TMS CUSTOM Statement Abbreviations

Statement or Parameter	Abbreviation
NAME	TMSNAME
NOEXPIRECHECK	NOEXPCHK
EXPIRECHECK	EXPCHK

NAME

specifies the name for this TMS. Other statements (for example, SUBPOOL) can refer to this TMS name.

tmsname

the TMS name. You can specify a maximum of 10 characters. The default TMS name is 'TMS' followed by the number of the TMS statement.

WARNDAYS

specifies that LCM issues warning message LCM0324W if no volumes in the TMS have been referenced within the specified days. This parameter helps you detect an inactive TMS.

1| *days*

the days within which no volumes in the TMS have been referenced. LCM uses the most recent volume reference day (DaysSinceReferenceTMS) for comparison. Valid values are 0 to 9999 and the default is 1. Specify a value of 0 if you do not want LCM to perform this check.

DSN

specifies the DSname of the Custom Interface TMS's tape catalog.

You can specify DSN or DDNAME but not both. If you specify AGENT, you must also specify DSN.

dsname

the DSname of the TMS catalog. The file referenced by *dsname* must be a sequential file containing variable length records. Each record in the file provides TMS information about one volume.

DDNAME

specifies the ddname of the Custom Interface's TMS catalog.

You can specify DDNAME or DSN but not both.

ddname

The ddname of the JCL DD statement for the TMS catalog. The file referenced by *ddname* must be a sequential file containing variable length records. Each record in the file provides TMS information about one volume. The default is LCMTMSDB. For more information, see ["Using LCM with a Custom TMS Interface Module" on page 67](#).

AGENT

specifies that LCM accesses information for the specified TMS from an LCM Agent running on the specified host using the specified port.

If you specify AGENT, you must also specify DSN.

host

specifies the host where LCM Agent is running. You can specify an IP address or a host name.

port

specifies the port number of the LCM Agent. If *port* is not specified, the default is 3002.

NOEXPIRECHECK | EXPIRECHECK

specifies whether LCM ignores expiration information in the TMS and treats the volume as a nonscratch volume. When you specify NOEXPIRECHECK, you can use the residual data in the TMS catalog that contains the data set name and location code of the volume.

EXPIRECHECK specifies that ExLM should treat volumes that are marked expired in the TMS as expired volumes. ExLM treats expired volumes as CYCLESOON volumes; for more information, see [“CYCLESOON” on page 121](#).

NOEJBAD | EJBAD

specifies whether LCM ejects all scratch volumes marked defective by the TMS. The default is to not eject defective volumes (NOEJBAD).

You can also specify this parameter for all TMSs on the OPTIONS statement.

text

specifies the text of message SLS1251E that appears when the CAP door is unlocked to eject defective volumes. The text is a maximum of 32 characters. Enclose the text in single quotes if it contains blanks or other special characters.

IGNORE18TRKFLAG

specifies that LCM treats all volumes in the TMS as cartridge tapes (not reel tapes).

If you specify PICKSCR but not IGNORE18TRKFLAG, ExLM selects only non-LSM scratch volumes that are marked as cartridge tapes in the TMS for entry into an LSM.

Note – You can also specify this parameter for all TMSs on the OPTIONS statement.

MODNAME

specifies the name of the Custom Interface module for the TMS; for more information, see [“Using LCM with a Custom TMS Interface Module” on page 67](#).

modname

the module name. The default is LCMUX01.

PARM

specifies a variable-length text string (from zero to fifty characters in length), that is passed to the Custom Interface module; for more information, see [“Using LCM with a Custom TMS Interface Module” on page 67](#).

text

The text string. There is no default value for *text*.

Usage

Use the TMS CUSTOM statement to define and select processing options for a TMS that uses the LCM Custom TMS interface. For more information, see [“Using LCM with a Custom TMS Interface Module”](#) on page 67.

TMS OPEN

The TMS OPEN statement defines and selects processing options for Open Systems clients.

Syntax

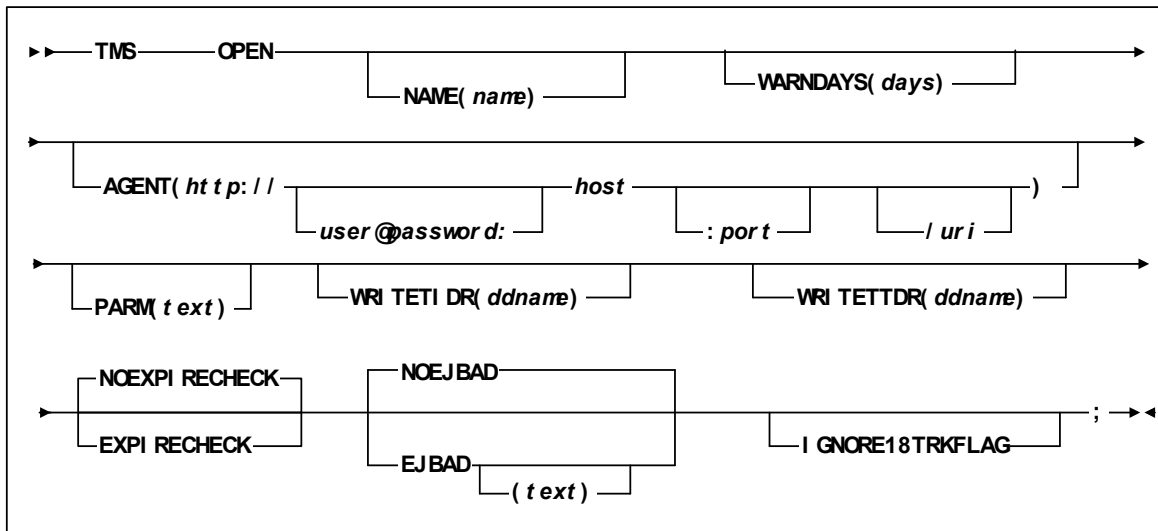

FIGURE 4-24 TMS OPEN Statement Syntax

Parameters

TABLE 4-17 lists the valid abbreviations for the TMS OPEN statement.

TABLE 4-17 TMS OPEN Statement Abbreviations

Statement or Parameter	Abbreviation
NAME	TMSNAME
NOEXPIRECHECK	NOEXPCHK
EXPIRECHECK	EXPCHK

NAME

specifies the name for this TMS. Other statements (for example, SUBPOOL) can refer to this TMS name.

tmsname

the TMS name. You can specify a maximum of 10 characters. The default TMS name is 'TMS' followed by the number of the TMS statement.

WARNDAYS

specifies that LCM issues warning message LCM0324W if no volumes in the TMS have been referenced within the specified days. This parameter helps you detect an inactive TMS.

1| days

the days within which no volumes in the TMS have been referenced. LCM uses the most recent volume reference day (DaysSinceReferenceTMS) for comparison. Valid values are 0 to 9999 and the default is 1. Specify a value of 0 if you do not want LCM to perform this check.

AGENT

Specifies that LCM accesses information for the specified TMS from a TMS Agent running on the specified host using the specified port and Uniform Resource Identifier. This parameter must be an absolute HTTP address as described in the HTTP 1.1 protocol (see rft 2616).

user@password

If the http server that LCM is connecting to requires authentication, then this will allow you to specify a user name and password that the server can authenticate.

host

Specifies the host where the TMS agent is running. You can specify an IP address or a host name.

port

Specifies the port number of where the TMS agent is running. If *port* is not specified, the default is 3002.

uri

Specifies the Uniform Resource Identifier to use when retrieving information about tape metadata for this TMS statement. If *uri* is not specified, '/tms' is used. For example, if you code the following:

AGENT (<http://storagetek.storagetek.com:3002/tapes/metadata/LCMAgent.cgi>)

Then LCM will POST its requests for this TMS OPEN statement to the indicated host and port using the uri /tapes/metadata/LCMAgent.cgi. The HTTP server on that host must be set up to accept and respond to LCM TMS OPEN requests.

PARAM

Specifies a variable-length text string (from zero to fifty characters in length) that is passed to the TMS agent. For more information on how to use this parameter see [“Using LCM with Open Systems Clients” on page 73](#).

text

The text string. There is no default value for text.

WRITETIDR

Specifies whether LCM writes out the TMS Interface Definition Response document that it receives from the TMS OPEN host to the DDName specified. If no DDName is specified then the DDName LCMTIDR will be used. See [“Using LCM with Open Systems Clients” on page 73](#) for more information regarding the TMS Interface Definition Response document.

WRITETTIR

Specifies whether LCM writes out the TMS Tape Information Response document that it receives from the TMS OPEN host to the DDName specified. If no DDName is specified then the DDName LCMTTIR will be used. See [“Using LCM with Open Systems Clients” on page 73](#) for more information regarding the TMS Tape Information Response document.

NOEXPIRECHECK | EXPIRECHECK

specifies whether LCM ignores expiration information in the TMS and treats the volume as a nonscratch volume. When you specify NOEXPIRECHECK, you can use the residual data in the TMS catalog that contains the data set name and location code of the volume.

EXPIRECHECK specifies that ExLM should treat volumes that are marked expired in the TMS as expired volumes. ExLM treats expired volumes as CYCLESOON volumes; for more information, see [“CYCLESOON” on page 121](#).

NOEJBAD | EJBAD

specifies whether LCM ejects all scratch volumes marked defective by the TMS. The default is to not eject defective volumes (NOEJBAD).

You can also specify this parameter for all TMSs on the OPTIONS statement.

text

specifies the text of message SLS1251E that appears when the CAP door is unlocked to eject defective volumes. The text is a maximum of 32 characters.

Enclose the text in single quotes if it contains blanks or other special characters.

IGNORE18TRKFLAG

specifies that LCM treats all volumes in the TMS as cartridge tapes (not reel tapes).

If you specify PICKSCR but not IGNORE18TRKFLAG, ExLM selects only non-LSM scratch volumes that are marked as cartridge tapes in the TMS for entry into an LSM.

Note – You can also specify this parameter for all TMSs on the OPTIONS statement.

Usage

Use the TMS OPEN statement to define and select processing options for Open Systems clients. For more information, see [“Using LCM with Open Systems Clients”](#) on page 73.

TMS RMM

The TMS RMM statement defines DFSMSrmm to LCM and selects processing options for DFSMSrmm.

Syntax

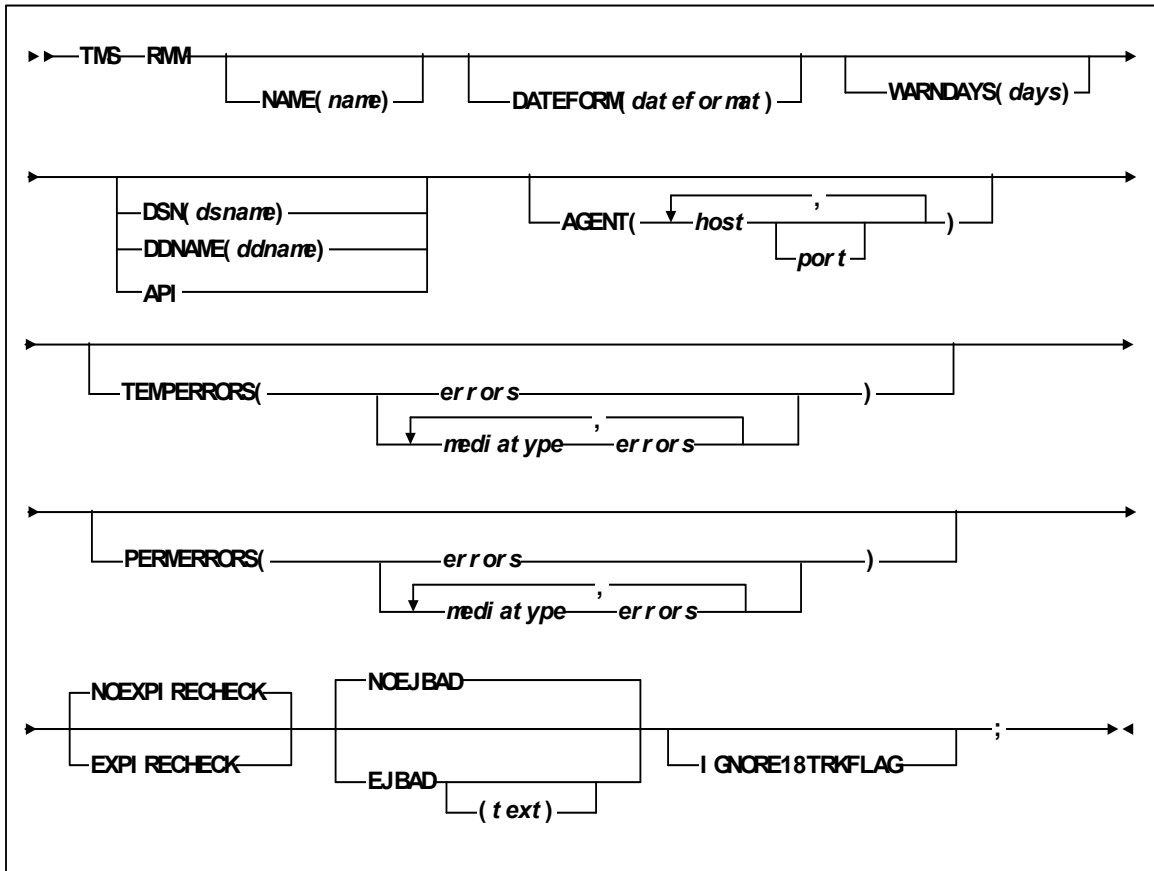

FIGURE 4-25 TMS RMM Statement Syntax

Parameters

TABLE 4-18 lists the valid abbreviations for the TMS RMM statement.

TABLE 4-18 TMS RMM Statement Abbreviations

Statement or Parameter	Abbreviation
NAME	TMSNAME
NOEXPIRECHECK	NOEXPCHK
EXPIRECHECK	EXPCHK
STANDARD	S, ST, STA, STAN, CST MEDIA1, STD, 1, 3480
LONG	L, LO, LON, ECART, E, ECCST, ETAPE, MEDIA2, 3490E
DD3A	A
DD3B	B
DD3C	C
ZCART	Z

NAME

specifies the name for this TMS. Other statements (for example, SUBPOOL) can refer to this TMS name.

tmsname

the TMS name. You can specify a maximum of 10 characters. The default TMS name is 'TMS' followed by the number of the TMS statement.

DATEFORM

specifies the date format for the extract file.

dateformat

one of the following:

- 'A' (American *mm/dd/yyyy*)
- 'J' (Julian *yyyy/ddd*)
- 'E' (European *dd/mm/yyyy*)
- 'I' (ISO *yyyy/mm/dd*)

If not specified, the default is 'I'.

WARNDAYS

specifies that LCM issues warning message LCM0324W if no volumes in the TMS have been referenced within the specified days. This parameter helps you detect an inactive TMS.

1| *days*

the days within which no volumes in the TMS have been referenced. LCM uses the most recent volume reference day (DaysSinceReferenceTMS) for comparison. Valid values are 0 to 9999 and the default is 1. Specify a value of 0 if you do not want LCM to perform this check.

DSN

specifies the DSname of the DFSMSRmm report extract data set.

DDNAME, DSN, and API are mutually exclusive.

dsname

the DSname of the DFSMSRmm report extract data set.

DDNAME

specifies the ddname of the DFSMSRmm report extract data set.

DDNAME, DSN, and API are mutually exclusive.

ddname

The ddname of the JCL DD statement for the DFSMSRmm report extract data set. The default is LCMTMSDB.

API

specifies that LCM obtains information from the RMM API.

DDNAME, DSN, and API are mutually exclusive.

Caution – The **disadvantage** of using the DFSMSRmm API is that you may experience a significant increase in execution time with the API compared to the extract file interface. The API, therefore, is the non-default interface except with LCM Agent.

AGENT

specifies that LCM accesses information for the specified TMS from an LCM Agent running on the specified host using the specified port.

host

specifies the host where LCM Agent is running. You can specify an IP address or a host name.

port

specifies the port number of the LCM Agent. If *port* is not specified, the default is 3002.

.TEMPERRORS

specifies the number of temporary read or temporary write errors that indicate a scratch volume is defective. For more information, see [“Using LCM with CA-TLMS” on page 57](#).

errors

the number of errors. Valid values are 1 to 9999 and the default value is 10. Setting this value to 0 will disable the function and LCM will not indicate a scratch volume as defective regardless of the number of temporary read or temporary write errors for the volume.

mediatype mediaerrors

the media type and number of errors. For *mediaerrors*, valid values are 1 to 9999 and the default value is 10. Setting this value to 0 will disable the function and LCM will not indicate a scratch volume as defective regardless of the number of temporary read or temporary write errors for the volume. For *mediatype*, the following are valid values:

STANDARD

Standard length 3480 cartridge. It can be used on any 4480 or 4490 transport. If written in 36 track mode on a 4490 transport, the data cannot be read by a 18 track 4480 transport.

LONG

3490E enhanced capacity (ECART) cartridge. It can be used only on 36 track transports (4490 or 9490) and can be visually identified by the two tone colored case.

DD3A

10 Gb capacity helical cartridge.

DD3B

25 Gb capacity helical cartridge.

DD3C

50 Gb capacity helical cartridge.

STK1R

250 Gb capacity 9840 cartridge.

STK2

any 9940 cartridge.

STK2P

60 Gb capacity 9940 cartridge.

ZCART

3490EE cartridge (ZCART), which can only be used in a 9490EE transport.

PERMERRORS

specifies the number of permanent read or permanent write errors that indicate a scratch volume is defective. For more information, see [“Using LCM with CA-TLMS” on page 57](#).

errors

the number of errors. Valid values are 1 and 9999 and the default value is 10. Setting this value to 0 will disable the function and LCM will not indicate a scratch volume as defective regardless of the number of permanent read or permanent write errors for the volume.

mediatype mediaerrors

the media type and number of errors. For *mediaerrors*, valid values are 1 to 9999 and the default value is 10. Setting this value to 0 will disable the function and LCM will not indicate a scratch volume as defective regardless of the number of permanent read or permanent write errors for the volume. See [“mediatype mediaerrors” on page 168](#) for valid values for the *mediatype* field.

NOEXPIRECHECK | EXPIRECHECK

specifies whether LCM ignores expiration information in the TMS and treats the volume as a nonscratch volume. When you specify NOEXPIRECHECK, you can use the residual data in the TMS catalog that contains the data set name and location code of the volume.

EXPIRECHECK specifies that ExLM should treat volumes that are marked expired in the TMS as expired volumes. ExLM treats expired volumes as CYCLESOON volumes; for more information, see [“CYCLESOON” on page 121](#).

NOEJBAD | EJBAD

specifies whether LCM ejects all scratch volumes marked defective by the TMS. The default is to not eject defective volumes (NOEJBAD).

You can also specify this parameter for all TMSs on the OPTIONS statement.

text

specifies the text of message SLS1251E that appears when the CAP door is unlocked to eject defective volumes. The text is a maximum of 32 characters. Enclose the text in single quotes if it contains blanks or other special characters.

IGNORE18TRKFLAG

specifies that LCM treats all volumes in the TMS as cartridge tapes (not reel tapes).

If you specify PICKSCR but not IGNORE18TRKFLAG, ExLM selects only non-LSM scratch volumes that are marked as cartridge tapes in the TMS for entry into an LSM.

Note – You can also specify this parameter for all TMSs on the OPTIONS statement.

Usage

Use the TMS RMM statement to define DFSMSrmm to LCM and select processing options for DFSMSrmm. For more information, see [“Using LCM with DFSMSrmm” on page 48](#).

TMS TLMS

The TMS TLMS statement defines CA-TLMS to LCM and selects processing options for CA-TLMS.

Syntax

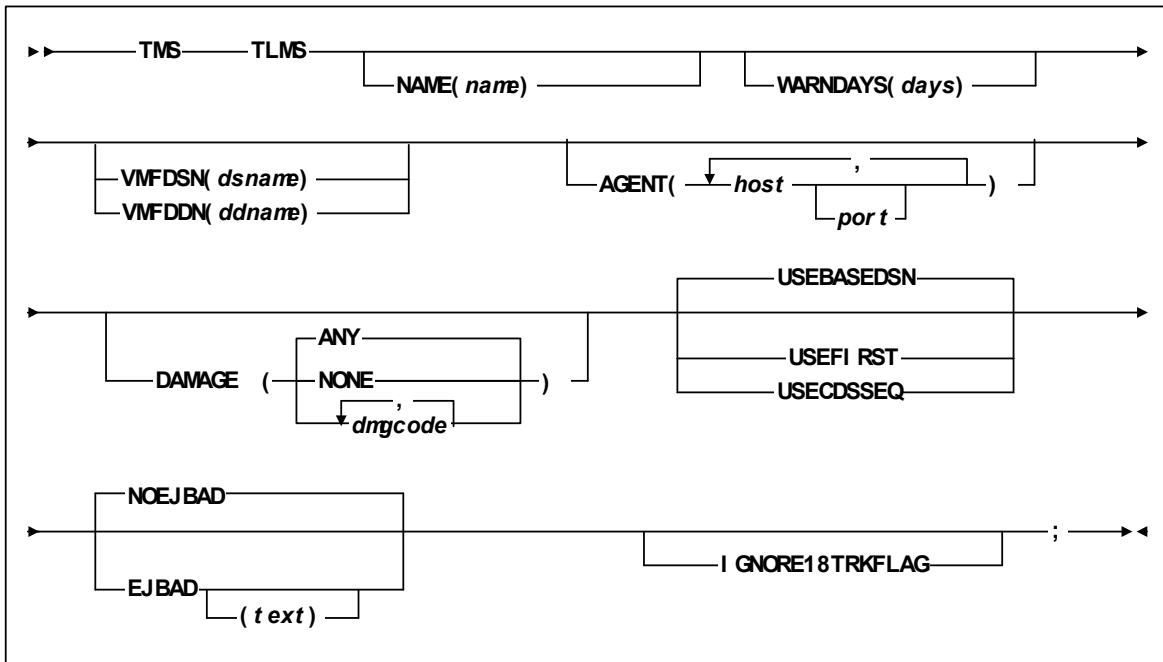

FIGURE 4-26 TMS TLMS Statement Syntax

Parameters

TABLE 4-19 lists the valid abbreviations for the TMS TLMS statement.

TABLE 4-19 TMS TLMS Statement Abbreviations

Statement or Parameter	Abbreviation
NAME	TMSNAME
NOEXPIRECHECK	NOEXPCHK
EXPIRECHECK	EXPCHK

NAME

specifies the name for this TMS. Other statements (for example, SUBPOOL) can refer to this TMS name.

tmsname

the TMS name. You can specify a maximum of 10 characters. The default TMS name is 'TMS' followed by the number of the TMS statement.

WARNDAYS

specifies that LCM issues warning message LCM0324W if no volumes in the TMS have been referenced within the specified days. This parameter helps you detect an inactive TMS.

1| *days*

the days within which no volumes in the TMS have been referenced. LCM uses the most recent volume reference day (DaysSinceReferenceTMS) for comparison. Valid values are 0 to 9999 and the default is 1. Specify a value of 0 if you do not want LCM to perform this check.

VMFDSN

specifies the dsname of the CA-TLMS Volume Master File (VMF).

You can specify either VMFDSN or VMFDD but not both.

dsname

the DSname of the CA-TLMS VMF.

VMFDD

specifies the ddname of the TLMS VMF.

You can specify either VMFDD or VMFDSN but not both.

ddname

The ddname of the JCL DD statement for the CA-TLMS VMF. The default is LCMTMSDB.

AGENT

specifies that LCM accesses information for the specified TMS from an LCM Agent running on the specified host using the specified port.

If you specify AGENT, you must also specify VMFDSN.

host

specifies the host where LCM Agent is running. You can specify an IP address or a host name.

port

specifies the port number of the LCM Agent. If *port* is not specified, the default is 3002.

DAMAGE (ANY | NONE | *dmgcode*)

specifies which characters in the CA-TLMS BADAMAGE field causes LCM to treat the volume as defective. For more information, see [“Using LCM with CA-TLMS” on page 57](#).

ANY

specifies that any character greater than X'40' in the CA-TLMS BADAMAGE field causes LCM to treat the volume as defective.

DAMAGE(ANY) is the default value if no DAMAGE parameter is specified.

NONE

specifies no character in the CA-TLMS BADAMAGE field marks the volume defective.

dmgcode

specifies which character(s) in the CA-TLMS BADAMAGE field are validated to determine if the volume is defective. Specify *dmgcode* as a single character enclosed in single quotes. The case of *dmgcode* characters is significant, so a lowercase 'y', for example, is not the same as an uppercase 'Y'. Multiple characters can be specified, so long as they are separated by one or more spaces. For example, the following is a valid way to specify multiple *dmgcode* values:

DAMAGE('y' 'Y')

USEBASEDSN

specifies that the BADSN field in the CA-TLMS VMF volume base record will be used as the controlling data set for each volume. USEBASEDSN is a default value if USECDSSEQ and USEFIRST are not specified. USEBASEDSN, USECDSSEQ, and USEFIRST are mutually exclusive.

USEFIRST

specifies that LCM groups all volumes in a multi-volume set by first volume serial number. All volumes in a multi-volume set use the controlling data set name, creation date, and creation time of the first volume in the set contained in the CA-TLMS VMF.

This allows you to assign a method based on the controlling data set name of the first volume in a set even when the controlling data set name is different for different volumes within the set.

Note –

1. The CA-TLMS tape retention system (TRS) separates a multi-volume set with multiple controlling data set names based on retention master file (RMF) data set qualifiers and retention criteria.
 2. If the controlling data set name of volume 2 through n in a set is different from volume 1, the Data Set Report displays the data set name and creation date of volume 1 for volumes 2 through n.
 3. The order of volumes in the Data Set Report may be different with this parameter specified.
 4. Approximately 20 percent more processing time is required for the additional sort of the CA-TLMS VMF.
-

USECDSSEQ

For TLMS release 5.4 and above only, specifies that the BACDSSEQ field in a VMF volume base record determines the controlling data set for each volume.

If any BACDSSEQ fields indicate the controlling data set for any volume is not the first file, some additional processing time occurs because LCM will read all TLMS VMF multi-data set records in addition to the volume base records.

USEBASEDSN is a default value if USECDSSEQ and USEFIRST are not specified. USEBASEDSN, USECDSSEQ, and USEFIRST are mutually exclusive.

NOEJBAD | EJBAD

specifies whether LCM ejects all scratch volumes marked defective by the TMS. The default is to not eject defective volumes (NOEJBAD).

You can also specify this parameter for all TMSs on the OPTIONS statement.

text

specifies the text of message SLS1251E that appears when the CAP door is unlocked to eject defective volumes. The text is a maximum of 32 characters.

Enclose the text in single quotes if it contains blanks or other special characters.

IGNORE18TRKFLAG

specifies that LCM treats all volumes in the TMS as cartridge tapes (not reel tapes).

If you specify PICKSCR but not IGNORE18TRKFLAG, ExLM selects only non-LSM scratch volumes that are marked as cartridge tapes in the TMS for entry into an LSM.

Note – You can also specify this parameter for all TMSs on the OPTIONS statement.

Usage

For more information, see [“Using LCM with CA-TLMS” on page 57](#).

UNMANAGED

The UNMANAGED statement specifies an LSM group that is not managed by LCM. LCM does not move, eject, or update HSC scratch status of the volumes in this LSM group. You can, however, produce reports for this LSM group.

Syntax

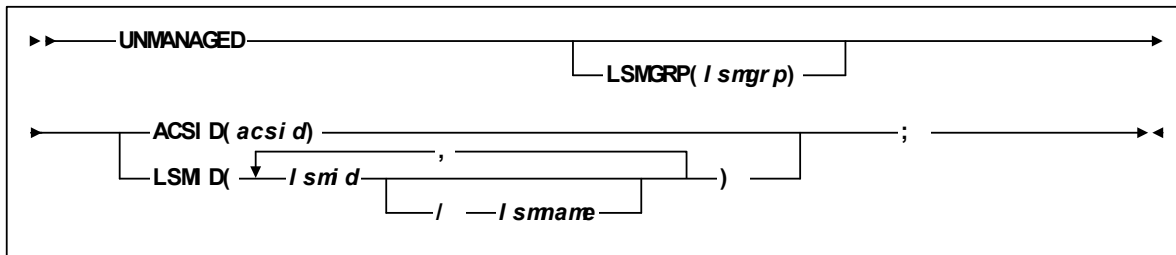

FIGURE 4-27 UNMANAGED Statement Syntax

Parameters

LSMGRP

specifies the name of the LSM group.

lsmgrp

the unique LSM group name. You can specify a maximum of 10 characters.

ACSID

specifies that the LSM group includes an entire ACS.

acsid

the hexadecimal ACS ID. Valid values are x'00' to x'FF'.

LSMID

specified the ID of an LSM in the group.

lsmid

the hexadecimal LSM ID. Valid values are '00:00' to 'FF:7F'.

lsmname

the name to use for this LSM for reporting purposes. Specify a maximum of 10 characters.

Usage

Use the `UNMANAGED` statement to specify an LSM group that is not managed by LCM. You can generate reports for this LSM group. LSM and LSM group names defined by the `UNMANAGED` statement can be used in `REPORT VOLUME WHEN` conditions.

Note the following restrictions:

- You can specify an LSM group in either a `MANAGE PHYSICAL` or `UNMANAGED` statement, but not both.
- An LSM group specified by an `UNMANAGED` statement cannot be referenced by the `LSMGRP` parameter of a `METHOD` statement.
- A LSM group specified by an `UNMANAGED` statement cannot be referenced by the `NEXT` parameter of a `MANAGE PHYSICAL` statement.
- Volumes in LSM groups specified by an `UNMANAGED` statement will not be assigned management methods. The `SET METHOD` statement does not apply to volumes in LSM groups specified by an `UNMANAGED` statement.

VAULT

The VAULT statement defines to LCM an ELS controlled vault and allows assignment of attributes of volumes assigned to the vault.

Syntax

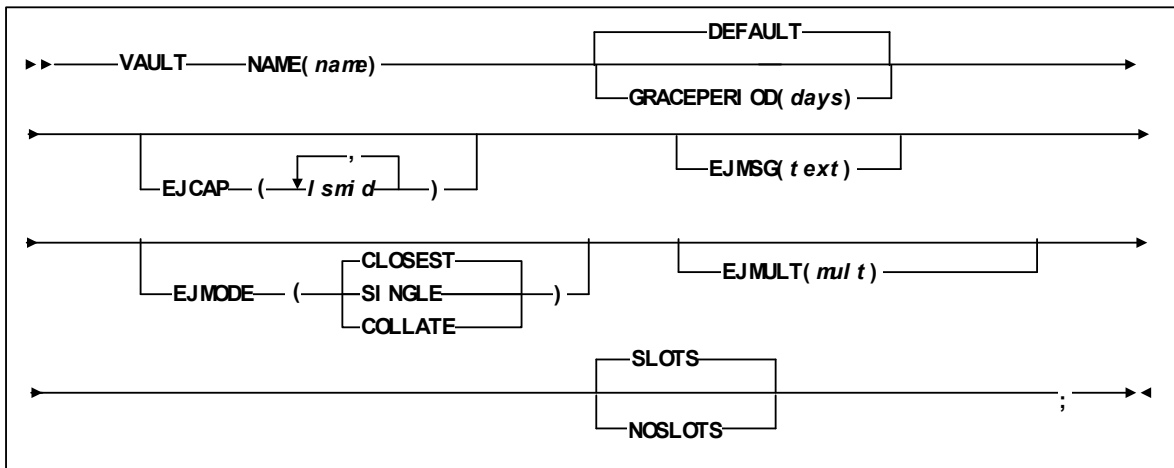

FIGURE 4-28 VAULT Statement Syntax

Parameters

NAME

specifies a unique name for this ELS-controlled vault. The specified name appears in the Reason column of reports for volumes processed by this ACTION statement.

name

the 1 to 10 character name. The default is Action followed by the number of the VAULT statement.

GRACEPERIOD(*days* | 3)

sets the number of days a volume assigned remains in the specified vault after being set to return. Default value is 3 days.

DEFAULT

specifies that this is the designated vault to hold volumes ejected to meet other LCM criteria. At ejection time, these volumes are automatically assigned to a slot in the named vault. When used, the GRACEPERIOD is set to 0 days and such volumes can be re-entered to the library at any time.

EJCAP

specifies a list of one or more LSMs whose CAPs are used for cartridge ejections. If this list does not contain at least one LSM for each managed ACS, LCM assumes that all LSMs in that ACS are available for use (which is also the default if you do not specify a value for EJCAP). ACTION EJCAP overrides this setting on the OPTIONS statement.

Alternatively, you can specify a specific CAP within an LSM.

lsmid

the hexadecimal LSM ID (00:00' to FF:7F'). Note that LCM will not use priority CAPs.

capid

the CAP ID in format *aa-ll-cc*. You can use the LCM DISPLAY, PAUSE, REDIRECT, and RESUME commands to manage LCM activity for specific CAPs; for more information, see [“LCM Operator Commands” on page 379](#).

EJMSG

specifies the text of the eject message (SLS1251E).

If you do not specify this parameter, LCM uses a text of 'Action Stmt' followed by a number indicating which ACTION statement is controlling the ejects. For example, if the fourth ACTION statement is controlling the ejects, the LCM job name is LCM, and the CAP is 00:00, the following messages will be issued when the CAP door is unlocked:

```
SLS0259A CAP PROCESSING TERMINATED; EMPTY CAPID 00:00
```

```
SLS1251E CAPID 00:00 (LCM): ACTION STMT 1
```

text

the message text, which is a maximum of 32 characters (longer strings are truncated to 32 characters). Enclose the character string in single quotes if it contains blanks or other special characters.

Any of the fields in the “ACTION Statement Fields” section of *LCM Quick Reference* can be specified in the text string by placing the ampersand character (“&”) before the field and a period (“.”) after the field. The period is optional if the character immediately following the field is not an alphanumeric or national character.

Note – A new EJMSG is generated for each CAP break using the text you specify. For example, if you specify CAP break on location name, you can include &locationname. as part of your message text as follows:

```
EJMSG('Location &locationname.')
```

EJMULT

eject volumes in multiples specified by *mult*. For example, for EJMULT(10), LCM ejects volumes in multiples of ten, which can include situations such as ejecting forty volumes at a time through an Enhanced CAP.

Note – You can use EJMULT to force volume ejections in amounts that fit evenly into cases or magazines for transport. For example, to fill a 10-cell magazine evenly, specify EJMULT(10).

EJMULT has no effect on the selection of a CAP for eject processing. For example, specifying EJMULT(40) does not prevent ExLM from selecting a 21-cell CAP for ejection.

StorageTek recommends that you do **not** specify an EJMULT value that is larger than the capacity of the smallest CAP used. For example, if you specify EJMULT(40) and a 21-cell CAP is used for ejects, LCM ejects volumes in batches of 40, which means that the operator has to empty the CAP twice (21 volumes followed by 19 volumes) for each batch of 40 volumes.

StorageTek also recommends that you do **not** specify large values (such as 200) for EJMULT. PAUSE commands (without the IMMED operand) do not take effect for a specific CAP until the current batch has been ejected, so large EJMULT values increase the delay before PAUSE commands take effect. There is no impact on PAUSE commands that specify the IMMED operand. The EJMULT parameter is only valid if CAPs of multiple LSMs are included in the EJCAP list and are available. ACTION EJMULT overrides this setting on the OPTIONS statement.

mult

the multiple that LCM uses to eject volumes. Valid values are 1 to 500 inclusive and the default is 1.

EJMODE

specifies that LCM uses the EJCAP list as follows:

CLOSEST

eject volumes through the CAPs closest to the volume location (the default).

SINGLE

eject volumes through the CAPs of only one LSM per ACS. LCM tries to minimize pass-throughs when it selects an LSM from the EJCAP list.

COLLATE

eject volumes through the CAPs of the LSMs in the EJCAP list in ascending order. ExLM ejects the lowest ordered set of volumes from the first EJCAP, the next lowest ordered set of volumes is ejected from the second EJCAP, and so forth. ExLM will use as many of the LSMs in the EJCAP list as can be used at least once. The “collating sequence” of volume ejections is either by slot number or volsers, depending on whether you specified SLOTS or NOSLOTS.

The EJMODE parameter is only valid if CAPs of multiple LSMs are included in the EJCAP list and are available. ACTION EJMODE overrides this setting on the OPTIONS statement.

SLOTS | NOSLOTS

specifies whether LCM volumes should be ejected by TMS slot numbers (SLOTS, the default) or by volsers (NOSLOTS).

Usage

Use the VAULT statement to defines to LCM an ELS controlled vault and allows assignment of attributes of volumes assigned to the vault. Ejection parameters apply when assigned volumes are being ejected unless specified in the statement performing the ejection.

LCM Action Control Statements

This chapter contains reference information for the following LCM control statements used to do *ad hoc* actions such as VTV consolidation, real volume ejection, and so forth.

ACTION CONSOLIDATE

The ACTION CONSOLIDATE statement consolidates VTVs.

Syntax

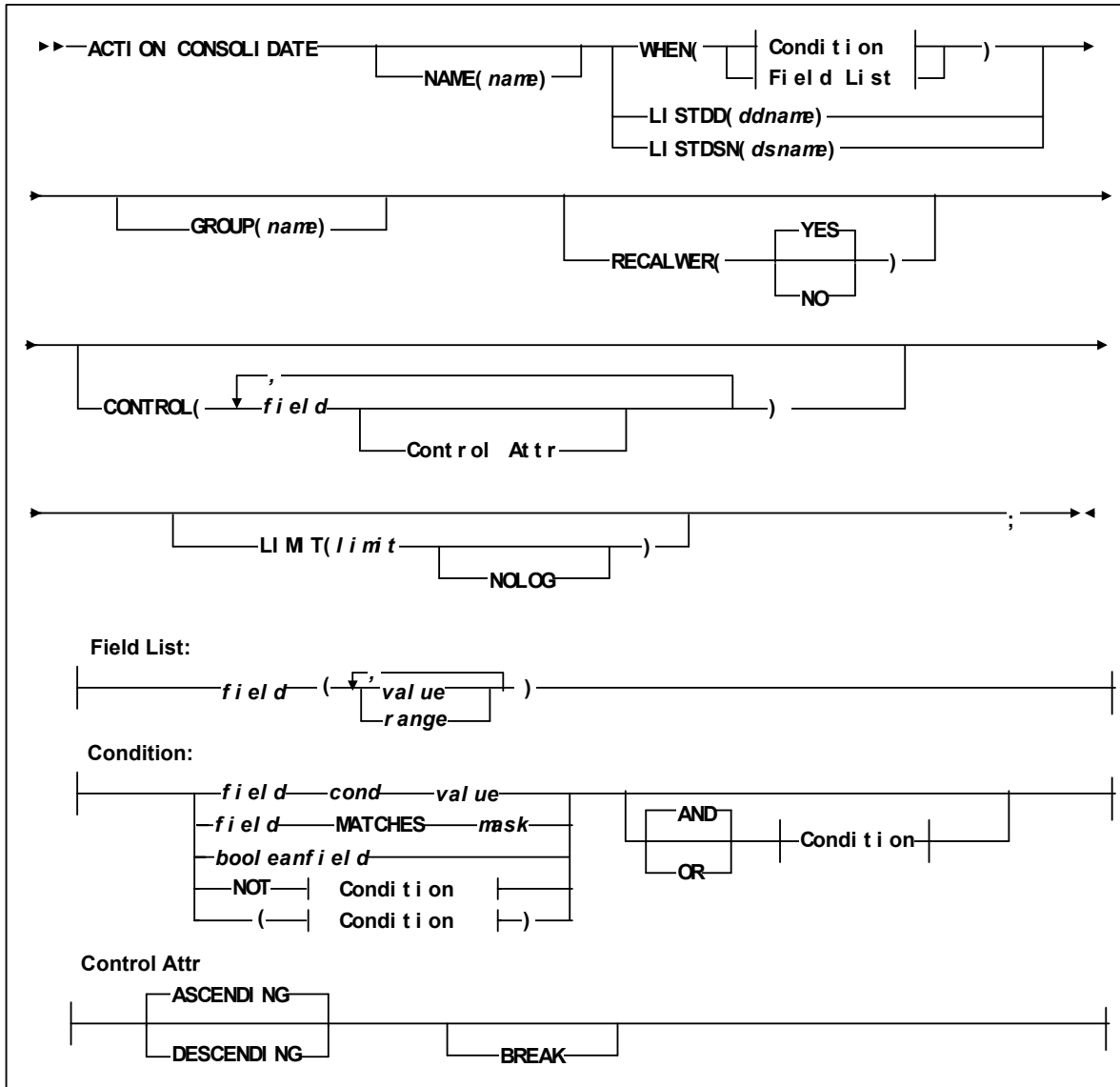

FIGURE 5-1 ACTION CONSOLIDATE Statement Syntax

Parameters

LISTDD

the DD name of a file containing volsers for selection.

ddname

the ddname.

LISTDSN

the data set name of a file containing volsers for selection.

dsname

the data set name.

Note – In the files specified on LISTDD or LISTDSN, each volsers start in column 1 on a new line. Volumes listed in a LISTDD or LISTDSN file that are not eligible for selection in the statement are not used. For example, if the ACTION EJECT statement specifies a file that lists volsers 397261, 397263, 397266 and 397263 does not reside in an LSM, it is not used.

WHEN(*condition*)

specifies one of the following for volume selection:

Field List

specifies the fields to use for volume selection. For a volume to be selected, the value for each *field* must match at least one of the provided *values* or *ranges*. The valid *values* depend on the type of *field* as described in [TABLE 5-1](#).

TABLE 5-1 Valid Types of Fields

Type	Values and Examples
Boolean	Specify TRUE or FALSE. FALSE is less than TRUE in comparisons.
Character or mixed character and integer string; also applies to ranges	Specify the string in single quotes. For example: WHEN(SERIAL('A00001')) WHEN(SERIAL('A00001'-'A99999'))
Date	Specify a date constant or MISSING. Date constants are of the form 'date'D or 'date'd where date can be specified in any date format defined in the "SET METHOD Statement WHEN Fields" section of <i>LCM Quick Reference</i> except TEXTDAYDATE. You must follow the format exactly. For example: '05Sep93'd is valid but '5Sep93'd is not.
Integer	Specify a number or MISSING. For example: 123
Time	Specify a time constant or MISSING. Time constants are of the form 'time'T where time can be specified in any time format defined in the "SET METHOD Statement WHEN Fields" section of <i>LCM Quick Reference</i> . You must follow the format exactly. For example: '12:30't is valid but '12;30't is not.

MISSING can also be specified as a period (“.”). MISSING is less than all other values.

TABLE 5-2 Valid Formats for Date Fields

Type	Size	Example
yyddd	5	97248
ccyyddd	7	1997248
yy.ddd	6	97.248
ccyy.ddd	8	1997.248
mm/dd/yy	8	09/05/97
mm/dd/ccyy	10	09/05/1997
yy-mm-dd	8	93-09-05
yyyy-mm-dd	10	2000-09-05 This is the default.
dd_mmm_yy	9	09 Sep 98
dd_mmm_ccyy	11	09 Sep 2000
ddmmmyy	7	09Sep98
ddmmccyy	9	09Sep1997
textdate	18	September 9, 2000
textdaydate	29	Wednesday, September 10, 2000

TABLE 5-3 Valid Formats for Time Fields

Type	Size	Example
hh:mm	5	22:21 This is the default.
hh:mm:ss	8	22:21:32
hh:mm:ss_pm	11	10:21:32 PM

Condition

specifies a condition for volume selection.

field cond value

specifies a field, a condition, and a value to compare with one of the following conditions:

EQ

equal to.

NE

not equal to.

GE

greater than or equal to.

GT

greater than.

LE

less than or equal to.

LT

less than.

For example, `VOLSER GE A00243` selects volsers greater than or equal to A00243.

field **MATCHES** *mask*

specifies a field and a mask for selection. The valid masks depend on the field selected:

■ **DATASETNAME, BASENAME:** Specify a string in single quotes. Wildcards can be used as follows:

“***” matches one or more data set qualifiers.

“*” matches one or more characters within a qualifier.

“%” matches one character within a qualifier.

■ **Other character fields:** Specify a string in single quotes. Wildcards can be used as follows:

“*” matches one or more characters.

“%” matches one character.

For example, `DataSetName MATCHES DR*` selects all data sets with HLQs beginning with DR.

booleanfield

specifies a Boolean field to be tested for TRUE. Specify NOT before the field if you want to test for FALSE.

For example, `CLN` selects volumes that are cleaning cartridges.

NOT

reverses the condition that immediately follows the NOT keyword.

For example, `NOT CLN` selects volumes that are **not** cleaning cartridges.

AND

make the selection if both conditions are true.

For example, `NOT CLN AND SERIAL(A00500-A00750)` selects volumes A00500 through A00750 that are **not** cleaning cartridges.

OR

make the selection if either condition is true. For example, `NOT CLN OR SERIAL(A00500-A00750)` selects volumes A00500 through A00750 **or** volumes that are not cleaning cartridges.

Note – For complete information on the fields available, their types, values, and use, see *LCM Quick Reference*.

GROUP

specifies a group name for the volumes.

name

the 1 to 8 character group name. The default is Default.

RECALWER

specifies whether VTCS recalls VTVs with read data checks.

YES

recall VTVs with read data checks (the default).

NO

do not recall VTVs with read data checks.

CONTROL

specifies one or more control fields, separated by commas, to indicate the order in which ExLM process volumes selected by this ACTION statement. The default is:

CONTROL(SERIAL ASCENDING).

field

specifies a sort field. The same volume fields available for specifying WHEN conditions can also be specified on the CONTROL parameter.

attr

specifies control information for the preceding sort field.

ASCENDING | DESCENDING

specifies whether to process the selected volumes in ascending or descending volser order.

BREAK

specifies that when any of the previously specified *fields* changes, ExLM completes the current consolidation request and begins a new one. This forces a new set of consolidation MVCs to be used for the next request. For example, if you specify:

CONTROL(LOCNAME BREAK, SLOTS, SERIAL)

ExLM processes volumes in location name, slot, and volume serial order—and begins a new consolidation request between location name changes.

You can only specify BREAK once in a CONTROL parameter. If you do not specify BREAK, ExLM does not begin a new request when control fields change.

LIMIT

specifies the maximum number of volumes processed by this ACTION statement. The limit is applied based on the sort order established by the CONTROL parameter.

limit

specify a number between 1 and 999999.

NOLOG

specifies that LCM does not issue message LCM2317.

Usage

Use the `ACTION CONSOLIDATE` statement to consolidate selected VTVs. You cannot consolidate VTVs that are already consolidated.

Note that you can also specify a consolidation group name on the `METHOD` statement; for more information, see [“METHOD” on page 106](#). If you specify the same group name on different statements or on different conditions within the same `METHOD` statement, all VTVs with the same group name are consolidated on a common set of consolidation MVCs. Use different consolidation group names to segregate different VTV groups on separate sets of consolidation MVCs.

ACTION DRAIN

The ACTION DRAIN statement recalls all current and scratched VTVs from selected MVC(s).

Syntax

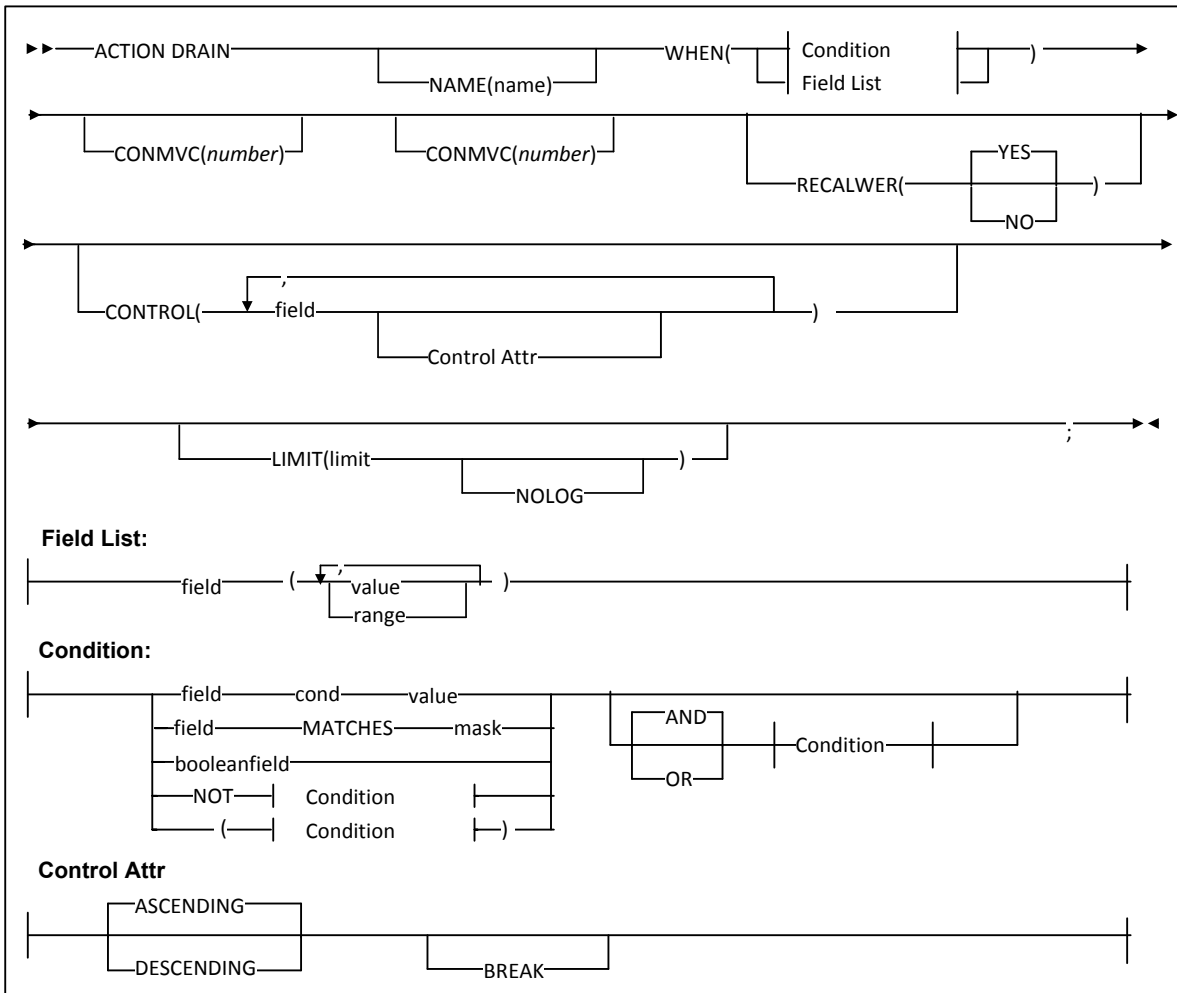

FIGURE 5-2 ACTION DRAIN Statement Syntax

Parameters

NAME

specifies a unique name for this ACTION statement. The specified name appears in the Reason column of reports for volumes processed by this ACTION statement.

name

the 1 to 10 character name. The default is Action followed by the number of the ACTION statement.

WHEN(*condition*)

specifies one of the following for volume selection:

Field List

specifies the fields to use for volume selection. For a volume to be selected, the value for each *field* must match at least one of the provided *values* or *ranges*. The valid *values* depend on the type of *field* as described in TABLE 5-1.

TABLE 5-4 Valid Types of Fields

Type	Values and Examples
Boolean	Specify TRUE or FALSE. FALSE is less than TRUE in comparisons.
Character or mixed character and integer string; also applies to ranges	Specify the string in single quotes. For example: WHEN(SERIAL('A00001')) WHEN(SERIAL('A00001'-'A99999'))
Date	Specify a date constant or MISSING. Date constants are of the form 'date'D or 'date'd where date can be specified in any date format defined in the "SET METHOD Statement WHEN Fields" section of <i>LCM Quick Reference</i> except TEXTDAYDATE. You must follow the format exactly. For example: '05Sep93'd is valid but '5Sep93'd is not.
Integer	Specify a number or MISSING. For example: 123
Time	Specify a time constant or MISSING. Time constants are of the form 'time'T where time can be specified in any time format defined in the "SET METHOD Statement WHEN Fields" section of <i>LCM Quick Reference</i> . You must follow the format exactly. For example: '12:30't is valid but '12;30't is not.

MISSING can also be specified as a period ("."). MISSING is less than all other values.

TABLE 5-5 Valid Formats for Date Fields

Type	Size	Example
yyddd	5	97248
ccyyddd	7	1997248
yy.ddd	6	97.248
ccyy.ddd	8	1997.248
mm/dd/yy	8	09/05/97
mm/dd/ccyy	10	09/05/1997
yy-mm-dd	8	93-09-05

TABLE 5-5 Valid Formats for Date Fields

Type	Size	Example
yyyy-mm-dd	10	2000-09-05 This is the default.
dd_mmm_yy	9	09 Sep 98
dd_mmm_ccyy	11	09 Sep 2000
ddmmmyy	7	09Sep98
ddmmmcyy	9	09Sep1997
textdate	18	September 9, 2000
textdaydate	29	Wednesday, September 10, 2000

TABLE 5-6 Valid Formats for Time Fields

Type	Size	Example
hh:mm	5	22:21 This is the default.
hh:mm:ss	8	22:21:32
hh:mm:ss_pm	11	10:21:32 PM

Condition

specifies a condition for volume selection.

field cond value

specifies a field, a condition, and a value to compare with one of the following conditions:

EQ

equal to.

NE

not equal to.

GE

greater than or equal to.

GT

greater than.

LE

less than or equal to.

LT

less than.

For example, `VOLSER GE A00243` selects volsers greater than or equal to A00243.

field MATCHES mask

specifies a field and a mask for selection. The valid masks depend on the field selected:

■ **DATASETNAME, BASENAME:** Specify a string in single quotes.

Wildcards can be used as follows:

`***` matches one or more data set qualifiers.

"*" matches one or more characters within a qualifier.

"%" matches one character within a qualifier.

- Other character fields: Specify a string in single quotes. Wildcards can be used as follows:

"*" matches one or more characters.

"%" matches one character.

For example, `DataSetName MATCHES DR*` selects all data sets with HLQs beginning with DR.

booleanfield

specifies a Boolean field to be tested for TRUE. Specify NOT before the field if you want to test for FALSE.

For example, `CLN` selects volumes that are cleaning cartridges.

NOT

reverses the condition that immediately follows the NOT keyword.

For example, `NOT CLN` selects volumes that are **not** cleaning cartridges.

AND

make the selection if both conditions are true.

For example, `NOT CLN AND SERIAL(A00500-A00750)` selects volumes A00500 through A00750 that are **not** cleaning cartridges.

OR

make the selection if either condition is true. For example, `NOT CLN OR SERIAL(A00500-A00750)` selects volumes A00500 through A00750 **or** volumes that are not cleaning cartridges.

Note – For complete information on the fields available, their types, values, and use, see *LCM Quick Reference*.

CONTROL

specifies the fields where breaks occur and the field sort order.

field

specifies a control field.

The volumes selected are sorted based on the control fields. You can use the **BREAK** subparameter to specify that a control break occurs when the value of a control field is different from the same field of the preceding volume.

You can specify the **HEADING**, **FOOTING**, and **SUMMARY | NOSUMMARY** subparameters before the first comma without coding a field name. This allows you to specify some text that is printed at the start of the report, at the end of the report, and just before the final summary line. Additionally, you can specify **NOSUMMARY** before the first comma to indicate that no final summary line is printed.

CONTROL (HEADING('Start of Report')

FOOTING('End of Report')

SUMMARY('Final Summary Line')

,

field ,

.
. .
.

)

Control Attr

specifies control information for the preceding control field.

ASCENDING | DESCENDING

specifies whether to sort the report records in ascending or descending order.

BREAK

specifies that a control break occurs when the value of the field changes. A control break also occurs for a field if a previously specified field has a control break. You can specify any number of control breaks.

HEADING

specifies the control break heading printed at the beginning of the control break when the value of the field changes. **HEADING** assumes the **BREAK** parameter.

One or more substitution variables can be specified for the control break heading. Any of the fields in the "REPORT VOLUME Statement Fields" section of *ExLM Quick Reference* can be specified by placing the ampersand character ("&") before the field and a period (".") after the field. The period is optional if the character immediately following the field is not an alphanumeric or national character. For example, &DATASETNAME. substitutes the value of DATASETNAME each time a control break occurs.

text

specifies the text for control break heading. Each text string will be printed on a separate line. You can use a null text string to print a blank line.

FOOTING

specifies the control break footing printed at the end of the control break when the value of the field changes. **FOOTING** assumes the **BREAK** parameter.

One or more substitution variables can be specified for the control break footing. Any of the fields in the "REPORT VOLUME Statement Fields" section of *LCM Quick Reference* can be specified by placing the ampersand character ("&") before the field and a period (".") after the field. The period is optional if the character immediately following the field is not an alphanumeric or national character. For example, &DATASETNAME. substitutes the value of DATASETNAME each time a control break occurs.

text

specifies the text for control break footing. Each text string will be printed on a separate line. You can use a null text string to print a blank line.

PAGE

specifies that a page break occurs when the value of field changes. PAGE assumes the BREAK parameter.

One or more substitution variables can be specified for the control break footing. Any of the fields in the "REPORT VOLUME Statement Fields" section of *LCM Quick Reference* can be specified by placing the ampersand character ("&") before the field and a period (".") after the field. The period is optional if the character immediately following the field is not an alphanumeric or national character. For example, &DATASETNAME. substitutes the value of DATASETNAME at the beginning of a page break.

text

specifies the page break text. To print a blank line, use the null (") text string. This *text* parameter is optional.

The PAGE text and the Report volume title print on the same line. If you specify a long PAGE text string and there is not enough room for a centered Report title, the PAGE text overlays the Report title.

CONMVC

specifies the maximum number of MVCs that can be mounted concurrently for this action.

number

The maximum number of concurrent MVCs to allow. Specify a value between 1 and 50.

If CONMVC is not specified, LCM does not specify it on the corresponding VTCS commands and the system-wide defaults apply.

MAXMVC

specifies the maximum number of MVCs that can be included on a single DRAIN or RECLAIM command.

number

The maximum number of MVCs to include on one command. Specify a value between 1 and 50. The default value is 1, if not specified.

RECALWER

specifies whether VTCS recalls VTVs with read data checks.

YES

recall VTVs with read data checks (the default).

NO

do not recall VTVs with read data checks.

LIMIT

specifies the maximum number of volumes processed by this ACTION statement. The limit is applied based on the sort order established by the CONTROL parameter.

limit

specify a number between 1 and 999999.

NOLOG

specifies that LCM does not issue message LCM2317.

Usage

Use the ACTION DRAIN statement to recall all current and scratched VTVs from selected MVC(s). Selection and control parameters provide for wide control of the selection of MVCs to drain and the order/limits of actual drains.

If the MVC being drained is assigned to an ELS controlled vault and is located outside the library, the return date for the volume is set as specified for volumes assigned to the that vault and all MVC flags are reset to allow usage of the MVC upon return to the library upon successful completion of the MVCDRAIN action.

If the MVC being drained is assigned to an ELS controlled vault and is inside the library, the MVCDRAIN is completed as specified, but no further actions are taken. Volume will be ejected to the vault upon the next eject run for that purpose and the now logically empty MVC will be processed by standard processes from that location. This scenario should not occur.

Example

The following ACTION DRAIN statement drains MVCs in the LOCAL Storage Class:
ACTION NAME(RECLLOC) DRAIN WHEN(MVCSTORCLAS EQ LOCAL);

ACTION EJECT

The ACTION EJECT statement ejects Nearline volumes.

Syntax

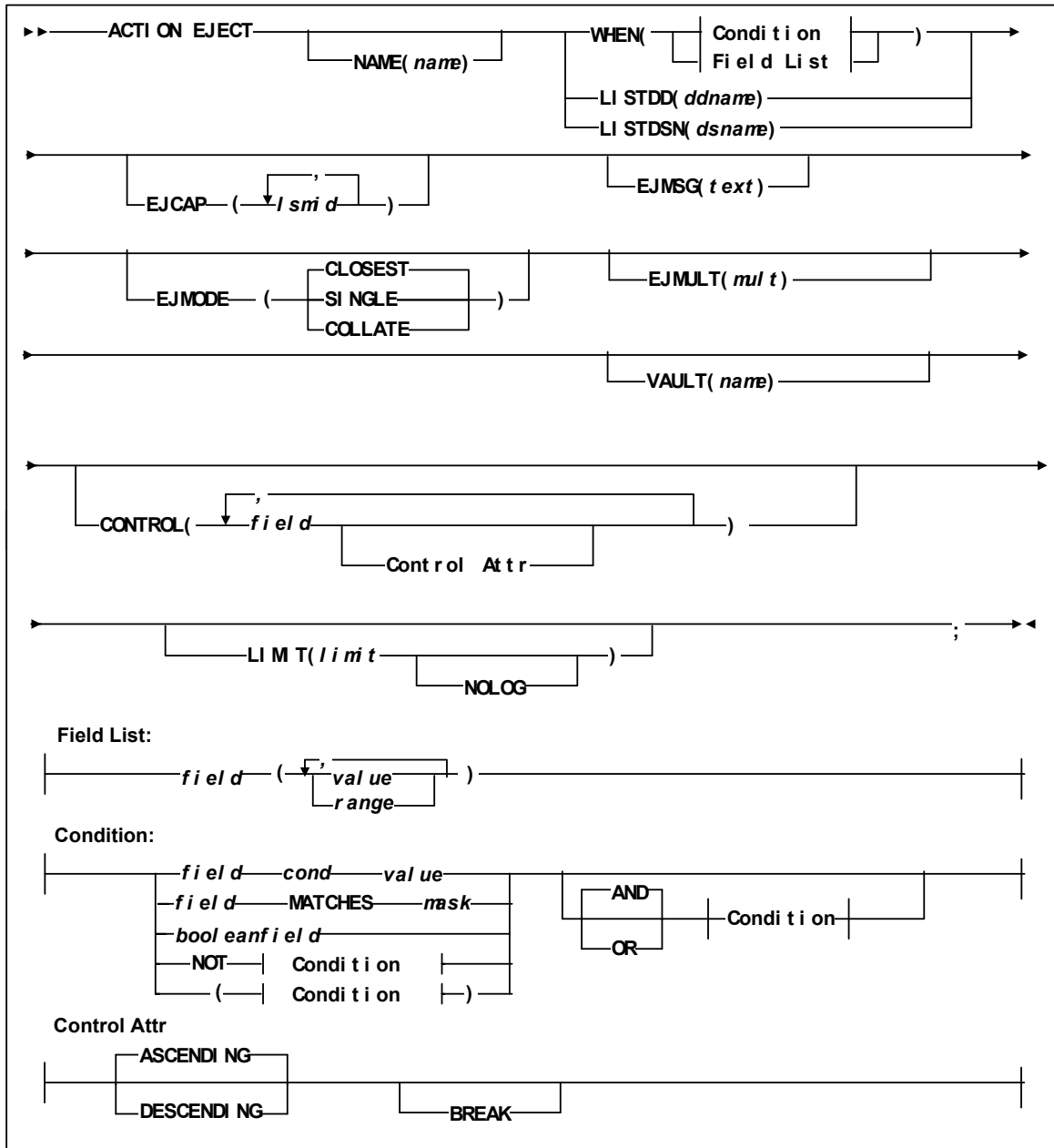

FIGURE 5-3 ACTION EJECT Statement Syntax

Parameters

NAME

specifies a unique name for this ACTION statement. The specified name appears in the Reason column of reports for volumes processed by this ACTION statement.

name

the 1 to 10 character name. The default is Action followed by the number of the ACTION statement.

WHEN(*condition*)

specifies one of the following for volume selection:

Field List

specifies the fields to use for volume selection. For a volume to be selected, the value for each *field* must match at least one of the provided *values* or *ranges*. The valid *values* depend on the type of *field* as described in TABLE 5-1.

TABLE 5-7 Valid Types of Fields

Type	Values and Examples
Boolean	Specify TRUE or FALSE. FALSE is less than TRUE in comparisons.
Character or mixed character and integer string; also applies to ranges	Specify the string in single quotes. For example: WHEN(SERIAL('A00001')) WHEN(SERIAL('A00001'-'A99999'))
Date	Specify a date constant or MISSING. Date constants are of the form 'date'D or 'date'd where date can be specified in any date format defined in the "SET METHOD Statement WHEN Fields" section of <i>LCM Quick Reference</i> except TEXTDAYDATE. You must follow the format exactly. For example: '05Sep93'd is valid but '5Sep93'd is not.
Integer	Specify a number or MISSING. For example: 123
Time	Specify a time constant or MISSING. Time constants are of the form 'time'T where time can be specified in any time format defined in the "SET METHOD Statement WHEN Fields" section of <i>LCM Quick Reference</i> . You must follow the format exactly. For example: '12:30't is valid but '12;30't is not.

MISSING can also be specified as a period ("."). MISSING is less than all other values.

TABLE 5-8 Valid Formats for Date Fields

Type	Size	Example
yyddd	5	97248
ccyyddd	7	1997248
yy.ddd	6	97.248
ccyy.ddd	8	1997.248
mm/dd/yy	8	09/05/97
mm/dd/ccyy	10	09/05/1997
yy-mm-dd	8	93-09-05

TABLE 5-8 Valid Formats for Date Fields

Type	Size	Example
yyyy-mm-dd	10	2000-09-05 This is the default.
dd_mmm_yy	9	09 Sep 98
dd_mmm_ccyy	11	09 Sep 2000
ddmmmyy	7	09Sep98
ddmmmcyy	9	09Sep1997
textdate	18	September 9, 2000
textdaydate	29	Wednesday, September 10, 2000

TABLE 5-9 Valid Formats for Time Fields

Type	Size	Example
hh:mm	5	22:21 This is the default.
hh:mm:ss	8	22:21:32
hh:mm:ss_pm	11	10:21:32 PM

Condition

specifies a condition for volume selection.

field cond value

specifies a field, a condition, and a value to compare with one of the following conditions:

EQ

equal to.

NE

not equal to.

GE

greater than or equal to.

GT

greater than.

LE

less than or equal to.

LT

less than.

For example, `VOLSER GE A00243` selects volsers greater than or equal to A00243.

field MATCHES mask

specifies a field and a mask for selection. The valid masks depend on the field selected:

■ **DATASETNAME, BASENAME:** Specify a string in single quotes.

Wildcards can be used as follows:

`***` matches one or more data set qualifiers.

"*" matches one or more characters within a qualifier.

"%" matches one character within a qualifier.

- Other character fields: Specify a string in single quotes. Wildcards can be used as follows:

"*" matches one or more characters.

"%" matches one character.

For example, `DataSetName MATCHES DR*` selects all data sets with HLQs beginning with DR.

booleanfield

specifies a Boolean field to be tested for TRUE. Specify NOT before the field if you want to test for FALSE.

For example, `CLN` selects volumes that are cleaning cartridges.

NOT

reverses the condition that immediately follows the NOT keyword.

For example, `NOT CLN` selects volumes that are **not** cleaning cartridges.

AND

make the selection if both conditions are true.

For example, `NOT CLN AND SERIAL(A00500-A00750)` selects volumes A00500 through A00750 that are **not** cleaning cartridges.

OR

make the selection if either condition is true. For example, `NOT CLN OR SERIAL(A00500-A00750)` selects volumes A00500 through A00750 **or** volumes that are not cleaning cartridges.

Note – For complete information on the fields available, their types, values, and use, see *LCM Quick Reference*.

LISTDD

the DD name of a file containing volsers for selection.

ddname

the ddname.

LISTDSN

the data set name of a file containing volsers for selection.

dsname

the data set name.

Note – In the files specified on LISTDD or LISTDSN, each volser start in column 1 on a new line. Volumes listed in a LISTDD or LISTDSN file that are not eligible for selection in the statement are not used. For example, if the ACTION EJECT statement specifies a file that lists volsers 397261, 397263, 397266 and 397263 does not reside in an LSM, it is not used.

EJCAP

specifies a list of one or more LSMs whose CAPs are used for cartridge ejections. If this list does not contain at least one LSM for each managed ACS, LCM assumes that all LSMs in that ACS are available for use (which is also the default if you do not specify a value for EJCAP). ACTION EJCAP overrides this setting on the OPTIONS statement.

Alternatively, you can specify a specific CAP within an LSM.

lsmid

the hexadecimal LSM ID (00:00' to FF:7F'). Note that LCM will not use priority CAPs.

capid

the CAP ID in format *aa-ll-cc*. You can use the LCM DISPLAY, PAUSE, REDIRECT, and RESUME commands to manage LCM activity for specific CAPs; for more information, see [“LCM Operator Commands” on page 379](#).

EJMSG

specifies the text of the eject message (SLS1251E).

If you do not specify this parameter, LCM uses a text of 'Action Stmt' followed by a number indicating which ACTION statement is controlling the ejects. For example, if the fourth ACTION statement is controlling the ejects, the LCM job name is LCM, and the CAP is 00:00, the following messages will be issued when the CAP door is unlocked:

```
SLS0259A CAP PROCESSING TERMINATED; EMPTY CAPID 00:00
```

```
SLS1251E CAPID 00:00 (LCM): ACTION STMT 1
```

text

the message text, which is a maximum of 32 characters (longer strings are truncated to 32 characters). Enclose the character string in single quotes if it contains blanks or other special characters.

Any of the fields in the “ACTION Statement Fields” section of *LCM Quick Reference* can be specified in the text string by placing the ampersand character (“&”) before the field and a period (“.”) after the field. The period is optional if the character immediately following the field is not an alphanumeric or national character.

Note – A new EJMSG is generated for each CAP break using the text you specify. For example, if you specify CAP break on location name, you can include &locationname. as part of your message text as follows:

```
EJMSG('Location &locationname.')
```

EJMODE

specifies that LCM uses the EJCAP list as follows:

CLOSEST

eject volumes through the CAPs closest to the volume location (the default).

SINGLE

eject volumes through the CAPs of only one LSM per ACS. LCM tries to minimize pass-throughs when it selects an LSM from the EJCAP list.

COLLATE

eject volumes through the CAPs of the LSMs in the EJCAP list in ascending order. ExLM ejects the lowest ordered set of volumes from the first EJCAP, the next lowest ordered set of volumes is ejected from the second EJCAP, and so forth. ExLM will use as many of the LSMs in the EJCAP list as can be used at least once. The “collating sequence” of volume ejections is either by slot number or volser, depending on whether you specified SLOTS or NOSLOTS.

The EJMODE parameter is only valid if CAPs of multiple LSMs are included in the EJCAP list and are available. ACTION EJMODE overrides this setting on the OPTIONS statement.

EJMULT

eject volumes in multiples specified by *mult*. For example, for EJMULT(10), LCM ejects volumes in multiples of ten, which can include situations such as ejecting forty volumes at a time through an Enhanced CAP.

Note – You can use EJMULT to force volume ejections in amounts that fit evenly into cases or magazines for transport. For example, to fill a 10-cell magazine evenly, specify EJMULT(10).

EJMULT has no effect on the selection of a CAP for eject processing. For example, specifying EJMULT(40) does not prevent ExLM from selecting a 21-cell CAP for ejection.

StorageTek recommends that you do **not** specify an EJMULT value that is larger than the capacity of the smallest CAP used. For example, if you specify EJMULT(40) and a 21-cell CAP is used for ejects, LCM ejects volumes in batches of 40, which means that the operator has to empty the CAP twice (21 volumes followed by 19 volumes) for each batch of 40 volumes.

StorageTek also recommends that you do **not** specify large values (such as 200) for EJMULT. PAUSE commands (without the IMMED operand) do not take effect for a specific CAP until the current batch has been ejected, so large EJMULT values increase the delay before PAUSE commands take effect. There is no impact on PAUSE commands that specify the IMMED operand. The EJMULT parameter is only valid if CAPs of multiple LSMs are included in the EJCAP list and are available. ACTION EJMULT overrides this setting on the OPTIONS statement.

mult

the multiple that LCM uses to eject volumes. Valid values are 1 to 500 inclusive and the default is 1.

VAULT

specifies that the volume being ejected is assigned a slot in the specified ELS controlled vault.

If a selected volume is already assigned to the specified ELS controlled vault, the volume is ejected and no further actions occur.

If a selected volume is assigned to another ELS controlled vault, the ejection will take place but a warning message is issued.

name

the name assigned in the VAULT parameter of the ACTION EXPORT statement in this run.

CONTROL

specifies one or more control fields, separated by commas, to indicate the order in which LCM process volumes selected by this ACTION statement. The default is:

CONTROL(SERIAL ASCENDING).

field

specifies a sort field. The same volume fields available for specifying WHEN conditions can also be specified on the CONTROL parameter.

attr

specifies control information for the preceding sort field.

ASCENDING | DESCENDING

specifies whether to process the selected volumes in ascending or descending volume order.

BREAK

specifies that when any of the previously specified *fields* changes, the CAP door must be emptied before ejections can resume. For example, if you specify:

CONTROL(LOCNAME BREAK, SLOTS, SERIAL)

LCM ejects volumes in location name, slot, and volume serial order—and waits for the CAP door to be emptied between location name changes.

You can only specify BREAK once in a CONTROL parameter. If you do not specify BREAK, LCM does not force the CAP to be emptied when control fields change.

LIMIT

specifies the maximum number of volumes processed by this ACTION statement. The limit is applied based on the sort order established by the CONTROL parameter.

limit

specify a number between 1 and 999999.

NOLOG

specifies that LCM does not issue message LCM2317.

Usage

Use the ACTION EJECT statement to eject Nearline volumes selected by the statement conditions. All volumes selected are ejected together per the ACTION EJECT parameters. ACTION EJECT only applies to Nearline volumes that reside in an LSM (managed or unmanaged). ACTION EJECT ejections have priority over other ejections. If you specify multiple ACTION EJECT statements, LCM performs the ejections in the same order as the statements appear in the parameter file.

For example, you can use the ACTION EJECT statement to eject used cleaning cartridges when you want rather than when HSC usually ejects them. For more information, see [“Using LCM to Manage Nearline Resources” on page 28](#).

Note – The Eject Utility has been functionally replaced by the capabilities of the ACTION EJECT statement; the Eject Utility is not provided with LCM 7.0 and above. The ExLM Eject Utility can still be executed from prior, supported versions of ExLM, but all support will cease in conjunction with the end of support for those releases.

ACTION EXPORT

The ACTION EXPORT statement exports VTVs and MVCs.

Syntax

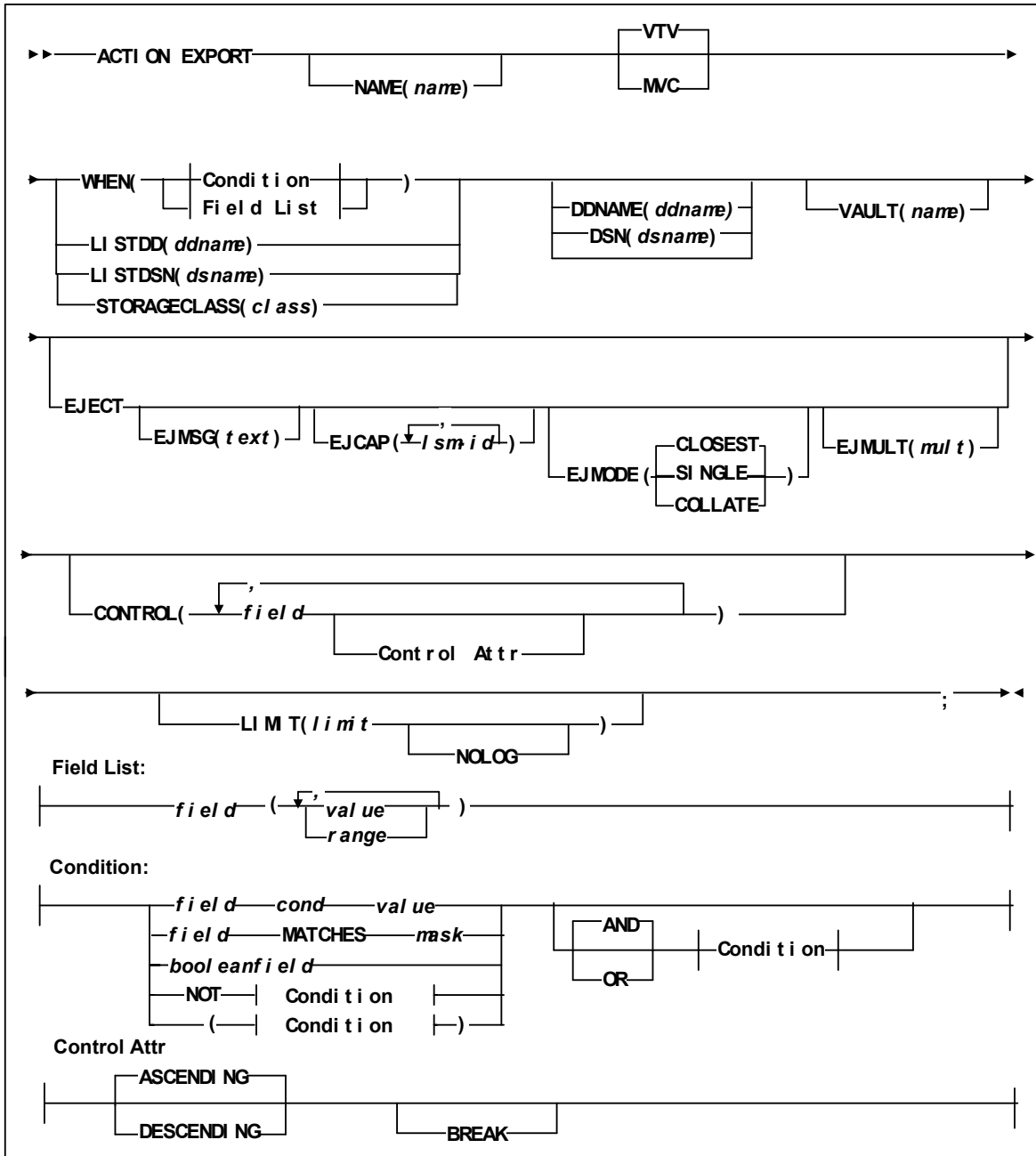

FIGURE 5-4 ACTION EXPORT Statement Syntax

Parameters

NAME

specifies a unique name for this ACTION statement. The specified name appears in the Reason column of reports for volumes processed by this ACTION statement.

name

the 1 to 10 character name. The default is Action followed by the number of the ACTION statement.

VTV | MVC

select volumes for export by MVC or VTV (the default).

The default is VTV indicating that VTVs selected by WHEN condition, LISTDSN or LISTDD will be consolidated on an MVC and that MVC then exported.

If MVC is selected, the MVCs selected by the WHEN condition, LISTDSN or LISTDD will be exported.

If STORAGECLASS is used in place of a WHEN condition, LISRDSN or LISTDD, MVC is assumed. (Storage Class only applies to MVCs).

WHEN(*condition*)

specifies one of the following for volume selection:

Field List

specifies the fields to use for volume selection. For a volume to be selected, the value for each *field* must match at least one of the provided *values* or *ranges*.

The valid *values* depend on the type of *field* as described in [TABLE 5-1](#).

TABLE 5-10 Valid Types of Fields

Type	Values and Examples
Boolean	Specify TRUE or FALSE. FALSE is less than TRUE in comparisons.
Character or mixed character and integer string; also applies to ranges	Specify the string in single quotes. For example: WHEN(SERIAL('A00001')) WHEN(SERIAL('A00001'-'A99999'))
Date	Specify a date constant or MISSING. Date constants are of the form 'date'D or 'date'd where date can be specified in any date format defined in the "SET METHOD Statement WHEN Fields" section of <i>LCM Quick Reference</i> except TEXTDAYDATE. You must follow the format exactly. For example: '05Sep93'd is valid but '5Sep93'd is not.
Integer	Specify a number or MISSING. For example: 123
Time	Specify a time constant or MISSING. Time constants are of the form 'time'T where time can be specified in any time format defined in the "SET METHOD Statement WHEN Fields" section of <i>LCM Quick Reference</i> . You must follow the format exactly. For example: '12:30't is valid but '12;30't is not.

MISSING can also be specified as a period (“.”). MISSING is less than all other values.

TABLE 5-11 Valid Formats for Date Fields

Type	Size	Example
yyddd	5	97248
ccyyddd	7	1997248
yy.ddd	6	97.248
ccyy.ddd	8	1997.248
mm/dd/yy	8	09/05/97
mm/dd/ccyy	10	09/05/1997
yy-mm-dd	8	93-09-05
yyyy-mm-dd	10	2000-09-05 This is the default.
dd_mmm_yy	9	09 Sep 98
dd_mmm_ccyy	11	09 Sep 2000
ddmmyy	7	09Sep98
ddmmccyy	9	09Sep1997
textdate	18	September 9, 2000
textdaydate	29	Wednesday, September 10, 2000

TABLE 5-12 Valid Formats for Time Fields

Type	Size	Example
hh:mm	5	22:21 This is the default.
hh:mm:ss	8	22:21:32
hh:mm:ss_pm	11	10:21:32 PM

Condition

specifies a condition for volume selection.

field cond value

specifies a field, a condition, and a value to compare with one of the following conditions:

EQ

equal to.

NE

not equal to.

GE

greater than or equal to.

GT

greater than.

LE

less than or equal to.

LT

less than.

For example, `VOLSER GE A00243` selects volsers greater than or equal to A00243.

field MATCHES *mask*

specifies a field and a mask for selection. The valid masks depend on the field selected:

■ **DATASETNAME, BASENAME:** Specify a string in single quotes. Wildcards can be used as follows:

“***” matches one or more data set qualifiers.

“*” matches one or more characters within a qualifier.

“%” matches one character within a qualifier.

■ **Other character fields:** Specify a string in single quotes. Wildcards can be used as follows:

“*” matches one or more characters.

“%” matches one character.

For example, `DataSetName MATCHES DR*` selects all data sets with HLQs beginning with DR.

booleanfield

specifies a Boolean field to be tested for TRUE. Specify NOT before the field if you want to test for FALSE.

For example, `CLN` selects volumes that are cleaning cartridges.

NOT

reverses the condition that immediately follows the NOT keyword.

For example, `NOT CLN` selects volumes that are **not** cleaning cartridges.

AND

make the selection if both conditions are true.

For example, `NOT CLN AND SERIAL(A00500-A00750)` selects volumes A00500 through A00750 that are **not** cleaning cartridges.

OR

make the selection if either condition is true. For example, `NOT CLN OR SERIAL(A00500-A00750)` selects volumes A00500 through A00750 **or** volumes that are not cleaning cartridges.

Note – For complete information on the fields available, their types, values, and use, see *LCM Quick Reference*.

LISTDD

the DD name of a file containing volsers for selection.

ddname

the ddname.

LISTDSN

the data set name of a file containing volsers for selection.

dsname

the data set name.

Note – In the files specified on LISTDD or LISTDSN, each volser start in column 1 on a new line. Volumes listed in a LISTDD or LISTDSN file that are not eligible for selection in the statement are not used. For example, if the ACTION EJECT statement specifies a file that lists volsers 397261, 397263, 397266 and 397263 does not reside in an LSM, it is not used.

STORAGECLASS

the MVC's assigned Storage Class.

The STORAGECLASS parameter is mutually exclusive with the WHEN, LISTDD and LISTDSN parameters. Additionally, LIMIT, as well as EJECT and its associated parameters, are not allowed with the STORAGECLASS parameter.

DDNAME

the DD name of the EXPORT Manifest File.

ddname

the ddname.

DSN

the data set name of the EXPORT Manifest File.

ddname

the ddname.

If you do not specify either DDNAME or DSN, LCM dynamically allocates an output data set for the Manifest File and logs message LCM23xx with the name of the Manifest File.

VAULT

assign the volume to a slot in the specified ELS controlled vault.

name

the name assigned in a VAULT statement in this run.

EJECT

specifies that LCM ejects:

- All exported MVCs,
- All MVCs used for consolidation of selected VTVs (if any), and
- All MVCs selected by the ACTION statement WHEN condition.

After any required VTV consolidations complete, MVCs ejected by an ACTION EXPORT statement are ejected together using the EJMSG, EJCAP, EJMODE, and EJMULT parameters from this statement.

EJMSG

specifies the text of the eject message (SLS1251E).

If you do not specify this parameter, LCM uses a text of 'Action Stmt' followed by a number indicating which ACTION statement is controlling the ejects. For example, if the fourth ACTION statement is controlling the ejects, the LCM job name is LCM, and the CAP is 00:00, the following messages will be issued when the CAP door is unlocked:

SLS0259A CAP PROCESSING TERMINATED; EMPTY CAPID 00:00

SLS1251E CAPID 00:00 (LCM): ACTION STMT 1

text

the message text, which is a maximum of 32 characters (longer strings are truncated to 32 characters). Enclose the character string in single quotes if it contains blanks or other special characters.

Any of the fields in the "ACTION Statement Fields" section of *LCM Quick Reference* can be specified in the text string by placing the ampersand character ("&") before the field and a period (".") after the field. The period is optional if the character immediately following the field is not an alphanumeric or national character.

Note – A new EJMSG is generated for each CAP break using the text you specify. For example, if you specify CAP break on location name, you can include &locationname. as part of your message text as follows:

EJMSG("Location &locationname.')

EJCAP

specifies a list of one or more LSMs whose CAPs are used for cartridge ejections. If this list does not contain at least one LSM for each managed ACS, LCM assumes that all LSMs in that ACS are available for use (which is also the default if you do not specify a value for EJCAP). ACTION EJCAP overrides this setting on the OPTIONS statement.

Alternatively, you can specify a specific CAP within an LSM.

lsmid

the hexadecimal LSM ID (00:00' to FF:7F'). Note that LCM will not use priority CAPs.

capid

the CAP ID in format *aa-ll-cc*. You can use the LCM DISPLAY, PAUSE, REDIRECT, and RESUME commands to manage LCM activity for specific CAPs; for more information, see "[LCM Operator Commands](#)" on page 379.

EJMODE

specifies that LCM uses the EJCAP list as follows:

CLOSEST

eject volumes through the CAPs closest to the volume location (the default).

SINGLE

eject volumes through the CAPs of only one LSM per ACS. LCM tries to minimize pass-throughs when it selects an LSM from the EJCAP list.

COLLATE

eject volumes through the CAPs of the LSMs in the EJCAP list in ascending order. ExLM ejects the lowest ordered set of volumes from the first EJCAP, the next lowest ordered set of volumes is ejected from the second EJCAP, and so forth. ExLM will use as many of the LSMs in the EJCAP list as can be used at least once. The “collating sequence” of volume ejections is either by slot number or volser, depending on whether you specified SLOTS or NOSLOTS.

The EJMODE parameter is only valid if CAPs of multiple LSMs are included in the EJCAP list and are available. ACTION EJMODE overrides this setting on the OPTIONS statement.

EJMODE

specifies that LCM uses the EJCAP list as follows:

CLOSEST

eject volumes through the CAPs closest to the volume location (the default).

SINGLE

eject volumes through the CAPs of only one LSM per ACS. LCM tries to minimize pass-throughs when it selects an LSM from the EJCAP list.

COLLATE

eject volumes through the CAPs of the LSMs in the EJCAP list in ascending order. ExLM ejects the lowest ordered set of volumes from the first EJCAP, the next lowest ordered set of volumes is ejected from the second EJCAP, and so forth. ExLM will use as many of the LSMs in the EJCAP list as can be used at least once. The “collating sequence” of volume ejections is either by slot number or volser, depending on whether you specified SLOTS or NOSLOTS.

The EJMODE parameter is only valid if CAPs of multiple LSMs are included in the EJCAP list and are available. ACTION EJMODE overrides this setting on the OPTIONS statement.

CONTROL

specifies one or more control fields, separated by commas, to indicate the order in which LCM process volumes selected by this ACTION statement. The default is:

CONTROL(SERIAL ASCENDING).

field

specifies a sort field. The same volume fields available for specifying WHEN conditions can also be specified on the CONTROL parameter.

attr

specifies control information for the preceding sort field.

ASCENDING | DESCENDING

specifies whether to process the selected volumes in ascending or descending volser order.

BREAK

specifies that when any of the previously specified *fields* changes, the CAP door must be emptied before ejects can resume. For example, if you specify:

CONTROL(LOCNAME BREAK, SLOTS, SERIAL)

LCM ejects volumes in location name, slot, and volume serial order—and waits for the CAP door to be emptied between location name changes.

You can only specify BREAK once in a CONTROL parameter. If you do not specify BREAK, LCM does not force the CAP to be emptied when control fields change.

LIMIT

specifies the maximum number of volumes processed by this ACTION statement. The limit is applied based on the sort order established by the CONTROL parameter.

limit

specify a number between 1 and 999999.

NOLOG

specifies that LCM does not issue message LCM2317.

Usage

Use the ACTION EXPORT statement to export selected VTVs and MVCs. Selected VTVs will be consolidated as needed. After consolidations are complete, a manifest file is produced for all MVCs involved in the Export operation, both MVCs used for consolidation and MVCs selected by the WHEN condition. The ACTION statement can optionally eject the MVCs after these operations complete. For more information, see [“Using LCM to do Exports” on page 33](#). See also [“ACTION CONSOLIDATE” on page 182](#).

Note that you can also specify an export group name on the METHOD statement. For more information, see [“METHOD” on page 106](#). If you specify the same export group name on different statements or on different conditions within the same METHOD statement, all volumes with the same export group name will be exported together.

Use different export group names to segregate different export operations.

Example of an ACTION statement:

```
action export
when(location = 'remote')
control(slot)
dsn(remote.manifest)
eject ejmsg('DR MVCs for Remote') ejcap(00:03);
```

This example action statement performs an EXPORT for all VTVs that have a Location name of Remote. The manifest file will be written to data set remote.manifest, which LCM will create if needed. Following the creation of the manifest file, LCM will eject the MVCs in ascending slot order through LSM 003's CAPs, using an eject message of 'DR MVCs for Remote'.

Note – When STORAGECLASS is specified, the ACTION EXPORT statement must be the first ACTION statement in the parameter file to prevent another ACTION statement from exerting control over the MVC.

ACTION MIGRATE

The ACTION MIGRATE statement migrates VTVs to MVCs.

Syntax

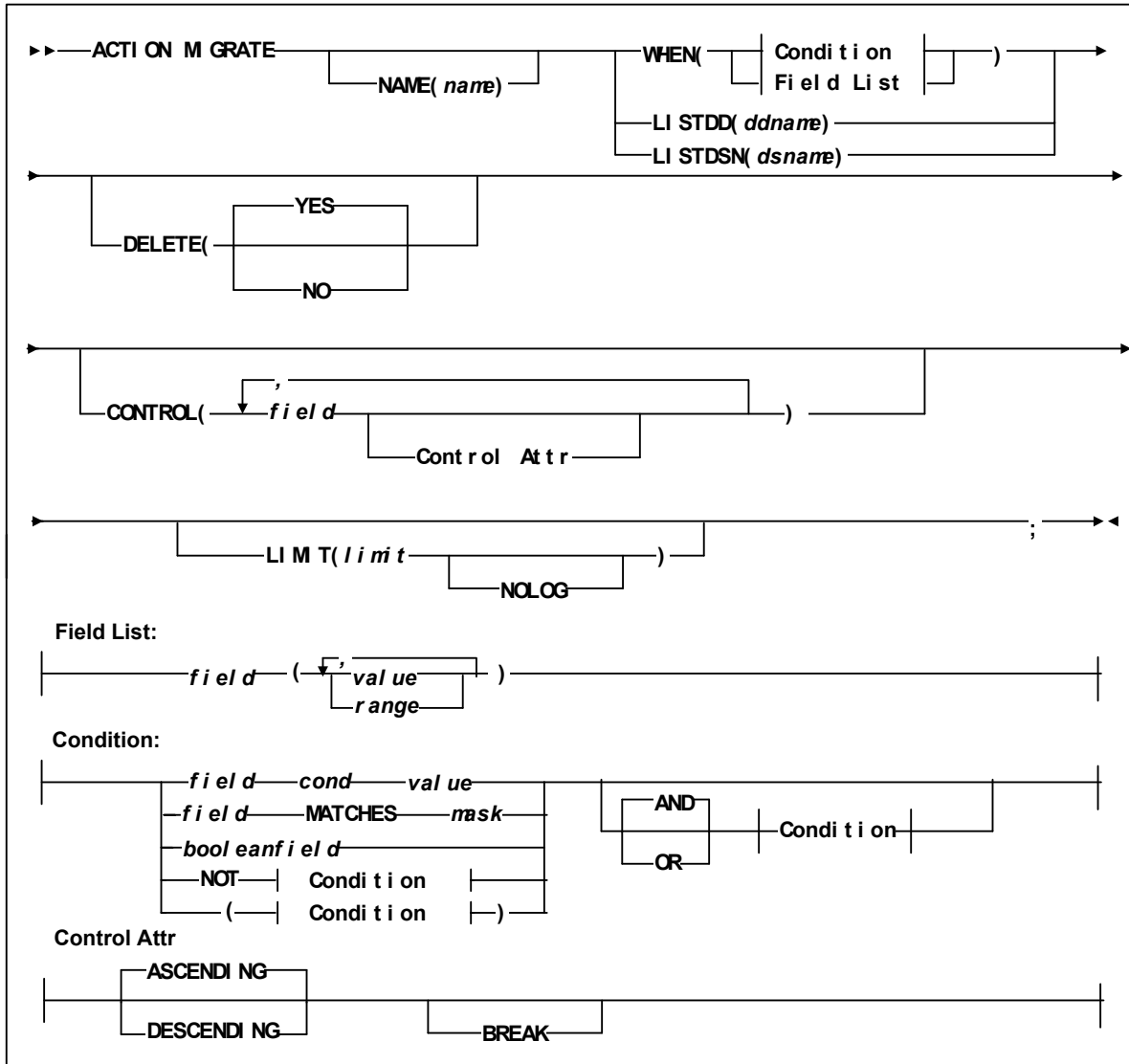

FIGURE 5-5 ACTION MIGRATE Statement Syntax

Parameters

NAME

specifies a unique name for this ACTION statement. The specified name appears in the Reason column of reports for volumes processed by this ACTION statement.

name

the 1 to 10 character name. The default is Action followed by the number of the ACTION statement.

WHEN(*condition*)

specifies one of the following for volume selection:

Field List

specifies the fields to use for volume selection. For a volume to be selected, the value for each *field* must match at least one of the provided *values* or *ranges*. The valid *values* depend on the type of *field* as described in TABLE 5-1.

TABLE 5-13 Valid Types of Fields

Type	Values and Examples
Boolean	Specify TRUE or FALSE. FALSE is less than TRUE in comparisons.
Character or mixed character and integer string; also applies to ranges	Specify the string in single quotes. For example: WHEN(SERIAL('A00001')) WHEN(SERIAL('A00001'-'A99999'))
Date	Specify a date constant or MISSING. Date constants are of the form 'date'D or 'date'd where date can be specified in any date format defined in the "SET METHOD Statement WHEN Fields" section of <i>LCM Quick Reference</i> except TEXTDAYDATE. You must follow the format exactly. For example: '05Sep93'd is valid but '5Sep93'd is not.
Integer	Specify a number or MISSING. For example: 123
Time	Specify a time constant or MISSING. Time constants are of the form 'time'T where time can be specified in any time format defined in the "SET METHOD Statement WHEN Fields" section of <i>LCM Quick Reference</i> . You must follow the format exactly. For example: '12:30't is valid but '12;30't is not.

MISSING can also be specified as a period ("."). MISSING is less than all other values.

TABLE 5-14 Valid Formats for Date Fields

Type	Size	Example
yyddd	5	97248
ccyyddd	7	1997248
yy.ddd	6	97.248
ccyy.ddd	8	1997.248
mm/dd/yy	8	09/05/97
mm/dd/ccyy	10	09/05/1997
yy-mm-dd	8	93-09-05

TABLE 5-14 Valid Formats for Date Fields

Type	Size	Example
yyyy-mm-dd	10	2000-09-05 This is the default.
dd_mmm_yy	9	09 Sep 98
dd_mmm_ccyy	11	09 Sep 2000
ddmmmyy	7	09Sep98
ddmmmcyy	9	09Sep1997
textdate	18	September 9, 2000
textdaydate	29	Wednesday, September 10, 2000

TABLE 5-15 Valid Formats for Time Fields

Type	Size	Example
hh:mm	5	22:21 This is the default.
hh:mm:ss	8	22:21:32
hh:mm:ss_pm	11	10:21:32 PM

Condition

specifies a condition for volume selection.

field cond value

specifies a field, a condition, and a value to compare with one of the following conditions:

EQ

equal to.

NE

not equal to.

GE

greater than or equal to.

GT

greater than.

LE

less than or equal to.

LT

less than.

For example, `VOLSER GE A00243` selects volsers greater than or equal to A00243.

field MATCHES mask

specifies a field and a mask for selection. The valid masks depend on the field selected:

■ **DATASETNAME, BASENAME:** Specify a string in single quotes.

Wildcards can be used as follows:

`***` matches one or more data set qualifiers.

"*" matches one or more characters within a qualifier.

"%" matches one character within a qualifier.

- Other character fields: Specify a string in single quotes. Wildcards can be used as follows:

"*" matches one or more characters.

"%" matches one character.

For example, `DataSetName MATCHES DR*` selects all data sets with HLQs beginning with DR.

booleanfield

specifies a Boolean field to be tested for TRUE. Specify NOT before the field if you want to test for FALSE.

For example, `CLN` selects volumes that are cleaning cartridges.

NOT

reverses the condition that immediately follows the NOT keyword.

For example, `NOT CLN` selects volumes that are **not** cleaning cartridges.

AND

make the selection if both conditions are true.

For example, `NOT CLN AND SERIAL(A00500-A00750)` selects volumes A00500 through A00750 that are **not** cleaning cartridges.

OR

make the selection if either condition is true. For example, `NOT CLN OR SERIAL(A00500-A00750)` selects volumes A00500 through A00750 **or** volumes that are not cleaning cartridges.

Note – For complete information on the fields available, their types, values, and use, see *LCM Quick Reference*.

LISTDD

the DD name of a file containing volsers for selection.

ddname

the ddname.

LISTDSN

the data set name of a file containing volsers for selection.

dsname

the data set name.

Note – In the files specified on LISTDD or LISTDSN, each volser start in column 1 on a new line. Volumes listed in a LISTDD or LISTDSN file that are not eligible for selection in the statement are not used. For example, if the ACTION EJECT statement specifies a file that lists volsers 397261, 397263, 397266 and 397263 does not reside in an LSM, it is not used.

DELETE

specifies whether to delete the VTVs from the VTSS after migration completes.

YES

delete VTVs after migration completes (the default).

NO

do not delete VTVs after migration completes.

CONTROL

specifies the fields where breaks occur and the field sort order.

field

specifies a control field.

The volumes selected are sorted based on the control fields. You can use the BREAK subparameter to specify that a control break occurs when the value of a control field is different from the same field of the preceding volume.

You can specify the HEADING, FOOTING, and SUMMARY | NOSUMMARY subparameters before the first comma without coding a field name. This allows you to specify some text that is printed at the start of the report, at the end of the report, and just before the final summary line. Additionally, you can specify NOSUMMARY before the first comma to indicate that no final summary line is printed.

CONTROL (HEADING('Start of Report')

FOOTING('End of Report')

SUMMARY('Final Summary Line')

,
field ,

.
. .
.

)

Control Attr

specifies control information for the preceding control field.

ASCENDING | DESCENDING

specifies whether to sort the report records in ascending or descending order.

BREAK

specifies that a control break occurs when the value of the field changes. A control break also occurs for a field if a previously specified field has a control break. You can specify any number of control breaks.

HEADING

specifies the control break heading printed at the beginning of the control break when the value of the field changes. HEADING assumes the BREAK parameter.

One or more substitution variables can be specified for the control break heading. Any of the fields in the "REPORT VOLUME Statement Fields" section of *ExLM Quick Reference* can be specified by placing the ampersand character ("&") before the field and a period (".") after the field. The period is optional if the character immediately following the field is not an alphanumeric or national character. For example, &DATASETNAME. substitutes the value of DATASETNAME each time a control break occurs.

text

specifies the text for control break heading. Each text string will be printed on a separate line. You can use a null text string to print a blank line.

FOOTING

specifies the control break footing printed at the end of the control break when the value of the field changes. FOOTING assumes the BREAK parameter.

One or more substitution variables can be specified for the control break footing. Any of the fields in the "REPORT VOLUME Statement Fields" section of *LCM Quick Reference* can be specified by placing the ampersand character ("&") before the field and a period (".") after the field. The period is optional if the character immediately following the field is not an alphanumeric or national character. For example, &DATASETNAME. substitutes the value of DATASETNAME each time a control break occurs.

text

specifies the text for control break footing. Each text string will be printed on a separate line. You can use a null text string to print a blank line.

PAGE

specifies that a page break occurs when the value of field changes. PAGE assumes the BREAK parameter.

One or more substitution variables can be specified for the control break footing. Any of the fields in the "REPORT VOLUME Statement Fields" section of *LCM Quick Reference* can be specified by placing the ampersand character ("&") before the field and a period (".") after the field. The period is optional if the character immediately following the field is not an alphanumeric or national character. For example, &DATASETNAME. substitutes the value of DATASETNAME at the beginning of a page break.

text

specifies the page break text. To print a blank line, use the null ("") text string. This *text* parameter is optional.

The PAGE text and the Report volume title print on the same line. If you specify a long PAGE text string and there is not enough room for a centered Report title, the PAGE text overlays the Report title.

LIMIT

specifies the maximum number of volumes processed by this ACTION statement. The limit is applied based on the sort order established by the CONTROL parameter.

limit

specify a number between 1 and 999999.

NOLOG

specifies that LCM does not issue message LCM2317.

Usage

Use the ACTION MIGRATE statement to migrate VTVs to MVCs.

Example

The following ACTION MIGRATE statement performs a migrate delete(yes) for all VTVs that exist in a VTSS and have gone unreferenced for more than 8 hours, but do not already have a migration copy.

```
ACTION MIGRATE DELETE(YES)WHEN(RHOURS GT 8);
```

ACTION MOVE

The ACTION MOVE statement moves selected Nearline volumes.

Syntax

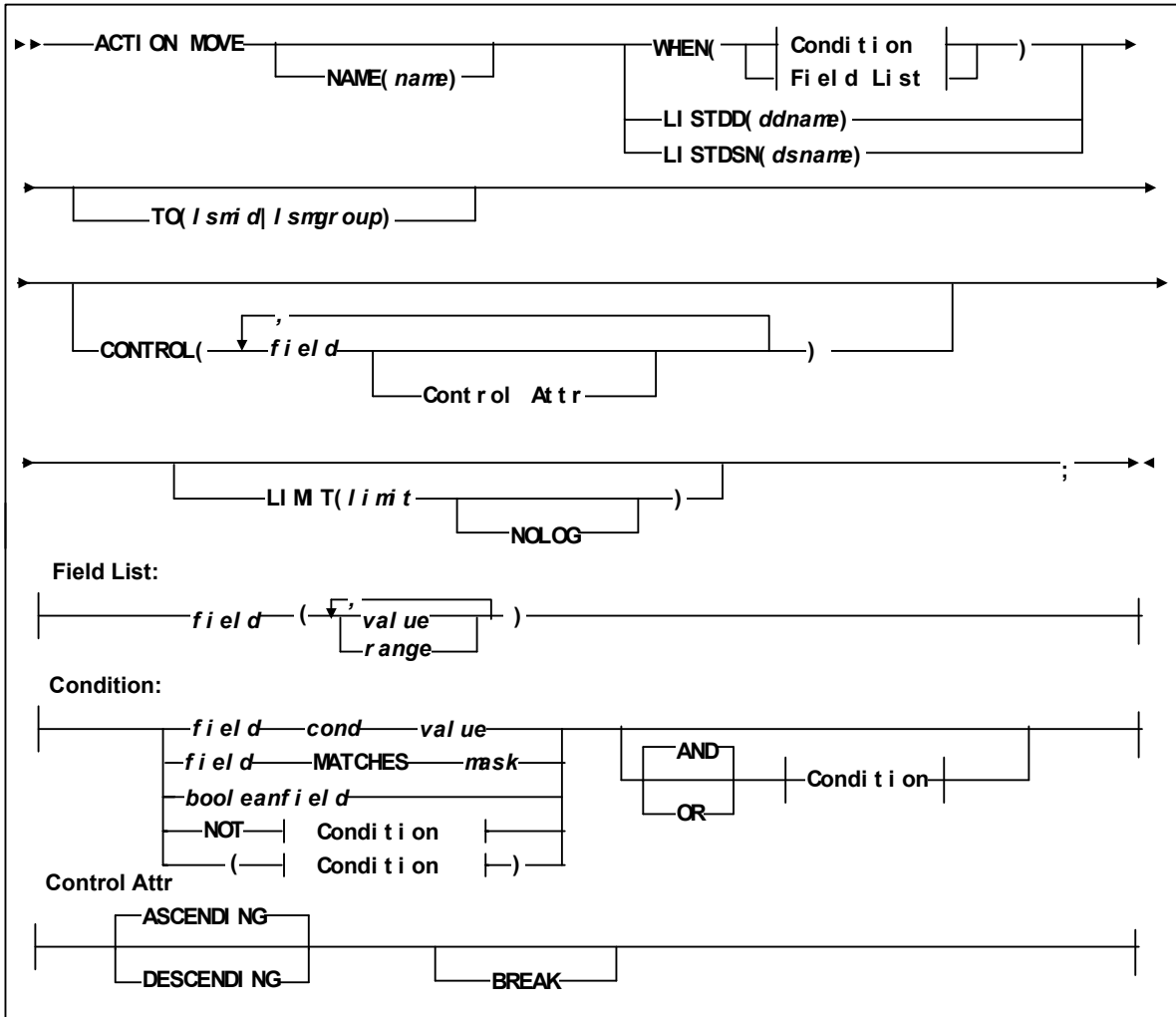

FIGURE 5-6 ACTION MOVE Statement Syntax

Parameters

NAME

specifies a unique name for this ACTION statement. The specified name appears in the Reason column of reports for volumes processed by this ACTION statement.

name

the 1 to 10 character name. The default is Action followed by the number of the ACTION statement.

WHEN(*condition*)

specifies one of the following for volume selection:

Field List

specifies the fields to use for volume selection. For a volume to be selected, the value for each *field* must match at least one of the provided *values* or *ranges*. The valid *values* depend on the type of *field* as described in TABLE 5-1.

TABLE 5-16 Valid Types of Fields

Type	Values and Examples
Boolean	Specify TRUE or FALSE. FALSE is less than TRUE in comparisons.
Character or mixed character and integer string; also applies to ranges	Specify the string in single quotes. For example: WHEN(SERIAL('A00001')) WHEN(SERIAL('A00001'-'A99999'))
Date	Specify a date constant or MISSING. Date constants are of the form 'date'D or 'date'd where date can be specified in any date format defined in the "SET METHOD Statement WHEN Fields" section of <i>LCM Quick Reference</i> except TEXTDAYDATE. You must follow the format exactly. For example: '05Sep93'd is valid but '5Sep93'd is not.
Integer	Specify a number or MISSING. For example: 123
Time	Specify a time constant or MISSING. Time constants are of the form 'time'T where time can be specified in any time format defined in the "SET METHOD Statement WHEN Fields" section of <i>LCM Quick Reference</i> . You must follow the format exactly. For example: '12:30't is valid but '12;30't is not.

MISSING can also be specified as a period ("."). MISSING is less than all other values.

TABLE 5-17 Valid Formats for Date Fields

Type	Size	Example
yyddd	5	97248
ccyyddd	7	1997248
yy.ddd	6	97.248
ccyy.ddd	8	1997.248
mm/dd/yy	8	09/05/97
mm/dd/ccyy	10	09/05/1997
yy-mm-dd	8	93-09-05
yyyy-mm-dd	10	2000-09-05 This is the default.
dd_mmm_yy	9	09 Sep 98

TABLE 5-17 Valid Formats for Date Fields

Type	Size	Example
dd_mmm_ccyy	11	09 Sep 2000
ddmmmyy	7	09Sep98
ddmmmcyy	9	09Sep1997
textdate	18	September 9, 2000
textdaydate	29	Wednesday, September 10, 2000

TABLE 5-18 Valid Formats for Time Fields

Type	Size	Example
hh:mm	5	22:21 This is the default.
hh:mm:ss	8	22:21:32
hh:mm:ss_pm	11	10:21:32 PM

Condition

specifies a condition for volume selection.

field cond value

specifies a field, a condition, and a value to compare with one of the following conditions:

EQ

equal to.

NE

not equal to.

GE

greater than or equal to.

GT

greater than.

LE

less than or equal to.

LT

less than.

For example, `VOLSER GE A00243` selects volsers greater than or equal to A00243.

field MATCHES mask

specifies a field and a mask for selection. The valid masks depend on the field selected:

■ **DATASETNAME, BASENAME:** Specify a string in single quotes.

Wildcards can be used as follows:

“***” matches one or more data set qualifiers.

“*” matches one or more characters within a qualifier.

“%” matches one character within a qualifier.

■ Other character fields: Specify a string in single quotes. Wildcards can be used as follows:

"*" matches one or more characters.

"%" matches one character.

For example, `DataSetName MATCHES DR*` selects all data sets with HLQs beginning with DR.

booleanfield

specifies a Boolean field to be tested for TRUE. Specify NOT before the field if you want to test for FALSE.

For example, `CLN` selects volumes that are cleaning cartridges.

NOT

reverses the condition that immediately follows the NOT keyword.

For example, `NOT CLN` selects volumes that are **not** cleaning cartridges.

AND

make the selection if both conditions are true.

For example, `NOT CLN AND SERIAL(A00500-A00750)` selects volumes A00500 through A00750 that are **not** cleaning cartridges.

OR

make the selection if either condition is true. For example, `NOT CLN OR SERIAL(A00500-A00750)` selects volumes A00500 through A00750 **or** volumes that are not cleaning cartridges.

Note – For complete information on the fields available, their types, values, and use, see *LCM Quick Reference*.

LISTDD

the DD name of a file containing volsers for selection.

ddname

the ddname.

LISTDSN

the data set name of a file containing volsers for selection.

dsname

the data set name.

Note – In the files specified on LISTDD or LISTDSN, each volser start in column 1 on a new line. Volumes listed in a LISTDD or LISTDSN file that are not eligible for selection in the statement are not used. For example, if the ACTION EJECT statement specifies a file that lists volsers 397261, 397263, 397266 and 397263 does not reside in an LSM, it is not used.

TO

specifies the target LSM for the move by one of the following:

lsmid

the target LSM in *AA:LL* format.

lsmgrp

the LSM group name defined on `MANAGE PHYSICAL`.

LIMIT

specifies the maximum number of volumes processed by this `ACTION` statement. The limit is applied based on the sort order established by the `CONTROL` parameter.

limit

specify a number between 1 and 999999.

NOLOG

specifies that LCM does not issue message LCM2317.

CONTROL

specifies the fields where breaks occur and the field sort order.

field

specifies a control field.

The volumes selected are sorted based on the control fields. You can use the `BREAK` subparameter to specify that a control break occurs when the value of a control field is different from the same field of the preceding volume.

You can specify the `HEADING`, `FOOTING`, and `SUMMARY | NOSUMMARY` subparameters before the first comma without coding a field name. This allows you to specify some text that is printed at the start of the report, at the end of the report, and just before the final summary line. Additionally, you can specify `NOSUMMARY` before the first comma to indicate that no final summary line is printed.

`CONTROL (HEADING('Start of Report')`

`FOOTING('End of Report')`

`SUMMARY('Final Summary Line')`

`,`

`field ,`

`.`

`.`

`.`

`)`

Control Attr

specifies control information for the preceding control field.

`ASCENDING | DESCENDING`

specifies whether to sort the report records in ascending or descending order.

`BREAK`

specifies that a control break occurs when the value of the field changes. A control break also occurs for a field if a previously specified field has a control break. You can specify any number of control breaks.

HEADING

specifies the control break heading printed at the beginning of the control break when the value of the field changes. HEADING assumes the BREAK parameter.

One or more substitution variables can be specified for the control break heading. Any of the fields in the "REPORT VOLUME Statement Fields" section of *ExLM Quick Reference* can be specified by placing the ampersand character ("&") before the field and a period (".") after the field. The period is optional if the character immediately following the field is not an alphanumeric or national character. For example, &DATASETNAME. substitutes the value of DATASETNAME each time a control break occurs.

text

specifies the text for control break heading. Each text string will be printed on a separate line. You can use a null text string to print a blank line.

FOOTING

specifies the control break footing printed at the end of the control break when the value of the field changes. FOOTING assumes the BREAK parameter.

One or more substitution variables can be specified for the control break footing. Any of the fields in the "REPORT VOLUME Statement Fields" section of *LCM Quick Reference* can be specified by placing the ampersand character ("&") before the field and a period (".") after the field. The period is optional if the character immediately following the field is not an alphanumeric or national character. For example, &DATASETNAME. substitutes the value of DATASETNAME each time a control break occurs.

text

specifies the text for control break footing. Each text string will be printed on a separate line. You can use a null text string to print a blank line.

PAGE

specifies that a page break occurs when the value of field changes. PAGE assumes the BREAK parameter.

One or more substitution variables can be specified for the control break footing. Any of the fields in the "REPORT VOLUME Statement Fields" section of *LCM Quick Reference* can be specified by placing the ampersand character ("&") before the field and a period (".") after the field. The period is optional if the character immediately following the field is not an alphanumeric or national character. For example, &DATASETNAME. substitutes the value of DATASETNAME at the beginning of a page break.

text

specifies the page break text. To print a blank line, use the null ("") text string. This *text* parameter is optional.

The PAGE text and the Report volume title print on the same line. If you specify a long PAGE text string and there is not enough room for a centered Report title, the PAGE text overlays the Report title.

LIMIT

specifies the maximum number of volumes processed by this ACTION statement. The limit is applied based on the sort order established by the CONTROL parameter.

limit

specify a number between 1 and 999999.

NOLOG

specifies that LCM does not issue message LCM2317.

Usage

Use the ACTION MOVE statement to move selected Nearline volumes.

Examples

FIGURE 5-7 shows an example of an ACTION MOVE statement to move all volumes selected for eject to an Extended Store LSM for later eject.

```
Action
Move                // When condition met, Move
* Move to Extended Store for Later Eject// Comment describing Action
When(                // Start Action condition
(InLSM EQ True )    // Volume is in a LSM
and                  // And also meets next condition
(VTV EQ False)      // Not a Virtual Volume
and                  // And also meets next condition
(MethodName EQ 'Eject') // Eject set as Method for Volume
)                    // End When Condition
To(00:05)            // Move volumes to 00:05
;                    // End of Action statement
```

FIGURE 5-7 ACTION MOVE Statement: move all volumes selected for eject to an Extended Store LSM for later eject

FIGURE 5-8 shows an example of an ACTION MOVE statement to force HSC to initiate errant volume recovery for all errant volumes.

```
Action
Move                // When condition met, Move
* Force Errant Recovery // Comment describing Action
When(                // Start Action condition
(InLSM EQ True)     // Volume is in a LSM
and                  // And also meets next condition
(VTV EQ False)      // Not a Virtual Volume
and                  // And also meets next condition
(Errant EQ True)    // HSC indicates volume is errant
)                    // End When Condition
To(00:00)           // Move volumes to 000
;                    // End of Action statement
```

FIGURE 5-8 ACTION MOVE Statement: force HSC to initiate errant volume recovery for all errant volumes

ACTION RECALL

The ACTION RECALL statement recalls migrated VTVs to a VTSS.

Syntax

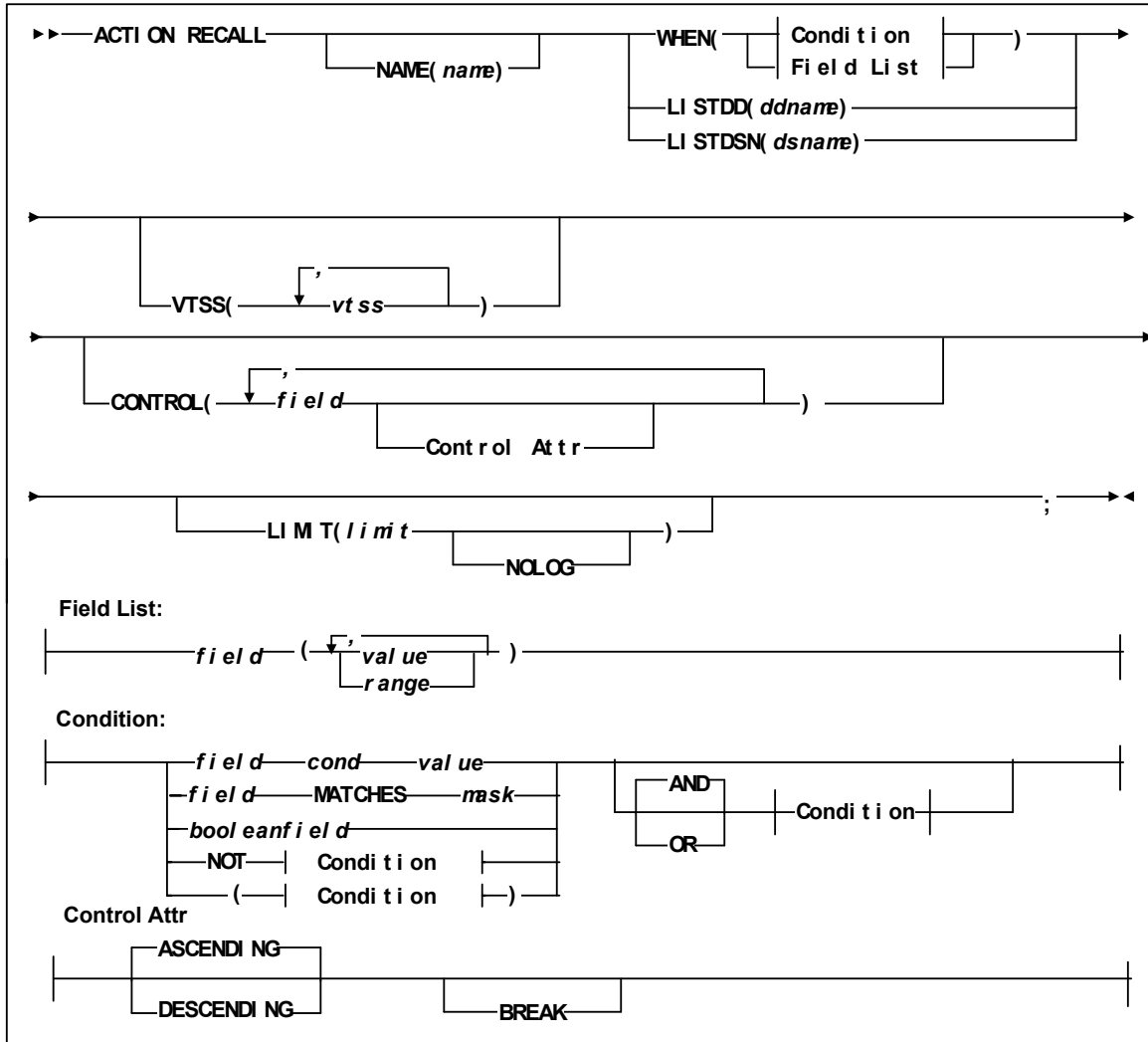

FIGURE 5-9 ACTION RECALL Statement Syntax

Parameters

NAME

specifies a unique name for this ACTION statement. The specified name appears in the Reason column of reports for volumes processed by this ACTION statement.

name

the 1 to 10 character name. The default is Action followed by the number of the ACTION statement.

WHEN(*condition*)

specifies one of the following for volume selection:

Field List

specifies the fields to use for volume selection. For a volume to be selected, the value for each *field* must match at least one of the provided *values* or *ranges*. The valid *values* depend on the type of *field* as described in TABLE 5-1.

TABLE 5-19 Valid Types of Fields

Type	Values and Examples
Boolean	Specify TRUE or FALSE. FALSE is less than TRUE in comparisons.
Character or mixed character and integer string; also applies to ranges	Specify the string in single quotes. For example: WHEN(SERIAL('A00001')) WHEN(SERIAL('A00001'-'A99999'))
Date	Specify a date constant or MISSING. Date constants are of the form 'date'D or 'date'd where date can be specified in any date format defined in the "SET METHOD Statement WHEN Fields" section of <i>LCM Quick Reference</i> except TEXTDAYDATE. You must follow the format exactly. For example: '05Sep93'd is valid but '5Sep93'd is not.
Integer	Specify a number or MISSING. For example: 123
Time	Specify a time constant or MISSING. Time constants are of the form 'time'T where time can be specified in any time format defined in the "SET METHOD Statement WHEN Fields" section of <i>LCM Quick Reference</i> . You must follow the format exactly. For example: '12:30't is valid but '12;30't is not.

MISSING can also be specified as a period ("."). MISSING is less than all other values.

TABLE 5-20 Valid Formats for Date Fields

Type	Size	Example
yyddd	5	97248
ccyyddd	7	1997248
yy.ddd	6	97.248
ccyy.ddd	8	1997.248
mm/dd/yy	8	09/05/97
mm/dd/ccyy	10	09/05/1997
yy-mm-dd	8	93-09-05
yyyy-mm-dd	10	2000-09-05 This is the default.

TABLE 5-20 Valid Formats for Date Fields

Type	Size	Example
dd_mmm_yy	9	09 Sep 98
dd_mmm_ccyy	11	09 Sep 2000
ddmmmyy	7	09Sep98
ddmmccyy	9	09Sep1997
textdate	18	September 9, 2000
textdaydate	29	Wednesday, September 10, 2000

TABLE 5-21 Valid Formats for Time Fields

Type	Size	Example
hh:mm	5	22:21 This is the default.
hh:mm:ss	8	22:21:32
hh:mm:ss_pm	11	10:21:32 PM

Condition

specifies a condition for volume selection.

field cond value

specifies a field, a condition, and a value to compare with one of the following conditions:

EQ

equal to.

NE

not equal to.

GE

greater than or equal to.

GT

greater than.

LE

less than or equal to.

LT

less than.

For example, `VOLSER GE A00243` selects volsers greater than or equal to A00243.

field MATCHES *mask*

specifies a field and a mask for selection. The valid masks depend on the field selected:

■ **DATASETNAME, BASENAME:** Specify a string in single quotes.

Wildcards can be used as follows:

“***” matches one or more data set qualifiers.

“*” matches one or more characters within a qualifier.

“%” matches one character within a qualifier.

■ Other character fields: Specify a string in single quotes. Wildcards can be used as follows:

“*” matches one or more characters.

“%” matches one character.

For example, DataSetName MATCHES DR* selects all data sets with HLQs beginning with DR.

booleanfield

specifies a Boolean field to be tested for TRUE. Specify NOT before the field if you want to test for FALSE.

For example, CLN selects volumes that are cleaning cartridges.

NOT

reverses the condition that immediately follows the NOT keyword.

For example, NOT CLN selects volumes that are **not** cleaning cartridges.

AND

make the selection if both conditions are true.

For example, NOT CLN AND SERIAL(A00500-A00750) selects volumes A00500 through A00750 that are **not** cleaning cartridges.

OR

make the selection if either condition is true. For example, NOT CLN OR SERIAL(A00500-A00750) selects volumes A00500 through A00750 **or** volumes that are not cleaning cartridges.

Note – For complete information on the fields available, their types, values, and use, see *LCM Quick Reference*.

LISTDD

the DD name of a file containing volsers for selection.

ddname

the ddname.

LISTDSN

the data set name of a file containing volsers for selection.

dsname

the data set name.

Note – In the files specified on LISTDD or LISTDSN, each volsers start in column 1 on a new line. Volumes listed in a LISTDD or LISTDSN file that are not eligible for selection in the statement are not used. For example, if the ACTION EJECT statement specifies a file that lists volsers 397261, 397263, 397266 and 397263 does not reside in an LSM, it is not used.

VTSS

specifies where the VTVs are recalled as follows:

- If you do not specify a VTSS (the default), VTCS recalls the VTVs to the VTSS of creation unless this VTSS does not have sufficient space. In this case, VTCS recalls the VTVs to the VTSS with the most available space.
- If you specify a single VTSS, VTCS attempts to recall the VTVs to the specified VTSS unless this VTSS does not have sufficient space. In this case, VTCS recalls the VTVs to the VTSS with the most available space.
- If you specify a list of VTVs, VTCS attempts to recall the VTVs to the VTSS of creation if it is on the list, otherwise VTCS recalls the VTVs to the VTSS with the most available space on the list.

vtss-name

A 1 to 8 character VTSS name.

CONTROL

specifies the fields where breaks occur and the field sort order.

field

specifies a control field.

The volumes selected are sorted based on the control fields. You can use the **BREAK** subparameter to specify that a control break occurs when the value of a control field is different from the same field of the preceding volume.

You can specify the **HEADING**, **FOOTING**, and **SUMMARY | NOSUMMARY** subparameters before the first comma without coding a field name. This allows you to specify some text that is printed at the start of the report, at the end of the report, and just before the final summary line. Additionally, you can specify **NOSUMMARY** before the first comma to indicate that no final summary line is printed.

CONTROL (HEADING('Start of Report')

FOOTING('End of Report')

SUMMARY('Final Summary Line')

,

field ,

.

.

.

)

Control Attr

specifies control information for the preceding control field.

ASCENDING | DESCENDING

specifies whether to sort the report records in ascending or descending order.

BREAK

specifies that a control break occurs when the value of the field changes. A control break also occurs for a field if a previously specified field has a control break. You can specify any number of control breaks.

HEADING

specifies the control break heading printed at the beginning of the control break when the value of the field changes. **HEADING** assumes the **BREAK** parameter.

One or more substitution variables can be specified for the control break footing. Any of the fields in the “REPORT VOLUME Statement Fields” section of *ExLM Quick Reference* can be specified by placing the ampersand character (“&”) before the field and a period (“.”) after the field. The period is optional if the character immediately following the field is not an alphanumeric or national character. For example, &DATASETNAME. substitutes the value of DATASETNAME each time a control break occurs.

text

specifies the text for control break heading. Each text string will be printed on a separate line. You can use a null text string to print a blank line.

FOOTING

specifies the control break footing printed at the end of the control break when the value of the field changes. **FOOTING** assumes the **BREAK** parameter.

One or more substitution variables can be specified for the control break footing. Any of the fields in the “REPORT VOLUME Statement Fields” section of *LCM Quick Reference* can be specified by placing the ampersand character (“&”) before the field and a period (“.”) after the field. The period is optional if the character immediately following the field is not an alphanumeric or national character. For example, &DATASETNAME. substitutes the value of DATASETNAME each time a control break occurs.

text

specifies the text for control break footing. Each text string will be printed on a separate line. You can use a null text string to print a blank line.

PAGE

specifies that a page break occurs when the value of field changes. **PAGE** assumes the **BREAK** parameter.

One or more substitution variables can be specified for the control break footing. Any of the fields in the “REPORT VOLUME Statement Fields” section of *LCM Quick Reference* can be specified by placing the ampersand character (“&”) before the field and a period (“.”) after the field. The period is optional if the character immediately following the field is not an alphanumeric or national character. For example, &DATASETNAME. substitutes the value of DATASETNAME at the beginning of a page break.

text

specifies the page break text. To print a blank line, use the null (“”) text string. This *text* parameter is optional.

The **PAGE** text and the Report volume title print on the same line. If you specify a long **PAGE** text string and there is not enough room for a centered Report title, the **PAGE** text overlays the Report title.

LIMIT

specifies the maximum number of volumes processed by this ACTION statement. The limit is applied based on the sort order established by the CONTROL parameter.

limit

specify a number between 1 and 999999.

NOLOG

specifies that LCM does not issue message LCM2317.

Usage

Use the ACTION RECALL statement to recall migrated VTVs.

Example

The following ACTION RECALL statement recalls VTVs that contain data sets with the name mask PAYR*.

```
ACTION RECALL VTSS(VTSS01) WHEN(DSN EQ PAYR*);
```

ACTION RECLAIM

The ACTION RECLAIM statement reclaims fragmented MVCs.

Syntax

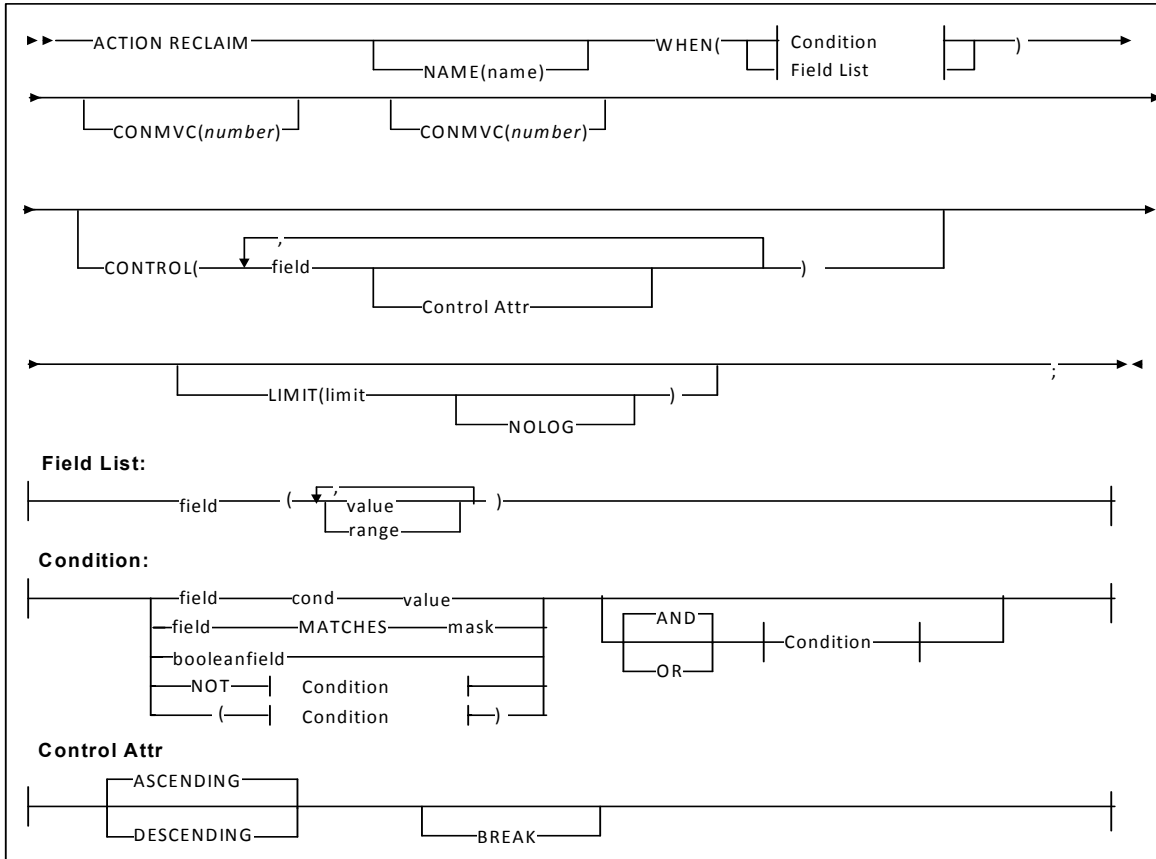

FIGURE 5-10 ACTION RECLAIM Statement Syntax

Parameters

NAME

specifies a unique name for this ACTION statement. The specified name appears in the Reason column of reports for volumes processed by this ACTION statement.

name

the 1 to 10 character name. The default is Action followed by the number of the ACTION statement.

WHEN(*condition*)

specifies one of the following for volume selection:

Field List

specifies the fields to use for volume selection. For a volume to be selected, the value for each *field* must match at least one of the provided *values* or *ranges*. The valid *values* depend on the type of *field* as described in [TABLE 5-1](#).

TABLE 5-22 Valid Types of Fields

Type	Values and Examples
Boolean	Specify TRUE or FALSE. FALSE is less than TRUE in comparisons.
Character or mixed character and integer string; also applies to ranges	Specify the string in single quotes. For example: WHEN(SERIAL('A00001')) WHEN(SERIAL('A00001'-'A99999'))
Date	Specify a date constant or MISSING. Date constants are of the form 'date'D or 'date'd where date can be specified in any date format defined in the "SET METHOD Statement WHEN Fields" section of <i>LCM Quick Reference</i> except TEXTDAYDATE. You must follow the format exactly. For example: '05Sep93'd is valid but '5Sep93'd is not.
Integer	Specify a number or MISSING. For example: 123
Time	Specify a time constant or MISSING. Time constants are of the form 'time'T where time can be specified in any time format defined in the "SET METHOD Statement WHEN Fields" section of <i>LCM Quick Reference</i> . You must follow the format exactly. For example: '12:30't is valid but '12;30't is not.

MISSING can also be specified as a period ("."). MISSING is less than all other values.

TABLE 5-23 Valid Formats for Date Fields

Type	Size	Example
yyddd	5	97248
ccyyddd	7	1997248
yy.ddd	6	97.248
ccyy.ddd	8	1997.248
mm/dd/yy	8	09/05/97
mm/dd/ccyy	10	09/05/1997

TABLE 5-23 Valid Formats for Date Fields

Type	Size	Example
yy-mm-dd	8	93-09-05
yyyy-mm-dd	10	2000-09-05 This is the default.
dd_mmm_yy	9	09 Sep 98
dd_mmm_ccyy	11	09 Sep 2000
ddmmmyy	7	09Sep98
ddmmccyy	9	09Sep1997
textdate	18	September 9, 2000
textdaydate	29	Wednesday, September 10, 2000

TABLE 5-24 Valid Formats for Time Fields

Type	Size	Example
hh:mm	5	22:21 This is the default.
hh:mm:ss	8	22:21:32
hh:mm:ss_pm	11	10:21:32 PM

Condition

specifies a condition for volume selection.

field cond value

specifies a field, a condition, and a value to compare with one of the following conditions:

EQ

equal to.

NE

not equal to.

GE

greater than or equal to.

GT

greater than.

LE

less than or equal to.

LT

less than.

For example, `VOLSER GE A00243` selects volsers greater than or equal to A00243.

field **MATCHES** *mask*

specifies a field and a mask for selection. The valid masks depend on the field selected:

- **DATASETNAME, BASENAME:** Specify a string in single quotes. Wildcards can be used as follows:

“***” matches one or more data set qualifiers.

“*” matches one or more characters within a qualifier.

“%” matches one character within a qualifier.

- Other character fields: Specify a string in single quotes. Wildcards can be used as follows:

“*” matches one or more characters.

“%” matches one character.

For example, `DataSetName MATCHES DR*` selects all data sets with HLQs beginning with DR.

booleanfield

specifies a Boolean field to be tested for TRUE. Specify NOT before the field if you want to test for FALSE.

For example, `CLN` selects volumes that are cleaning cartridges.

NOT

reverses the condition that immediately follows the NOT keyword.

For example, `NOT CLN` selects volumes that are **not** cleaning cartridges.

AND

make the selection if both conditions are true.

For example, `NOT CLN AND SERIAL(A00500-A00750)` selects volumes A00500 through A00750 that are **not** cleaning cartridges.

OR

make the selection if either condition is true. For example, `NOT CLN OR SERIAL(A00500-A00750)` selects volumes A00500 through A00750 **or** volumes that are not cleaning cartridges.

Note – For complete information on the fields available, their types, values, and use, see *LCM Quick Reference*.

CONMVC

specifies the maximum number of MVCs that can be mounted concurrently for this action.

number

The maximum number of concurrent MVCs to allow. Specify a value between 1 and 50.

If CONMVC is not specified, LCM does not specify it on the corresponding VTCS commands and the system-wide defaults apply.

MAXMVC

specifies the maximum number of MVCs that can be included on a single DRAIN or RECLAIM command.

number

The maximum number of MVCs to include on one command. Specify a value between 1 and 50. The default value is 1, if not specified.

CONTROL

specifies the fields where breaks occur and the field sort order.

field

specifies a control field.

The volumes selected are sorted based on the control fields. You can use the **BREAK** subparameter to specify that a control break occurs when the value of a control field is different from the same field of the preceding volume.

You can specify the **HEADING**, **FOOTING**, and **SUMMARY | NOSUMMARY** subparameters before the first comma without coding a field name. This allows you to specify some text that is printed at the start of the report, at the end of the report, and just before the final summary line. Additionally, you can specify **NOSUMMARY** before the first comma to indicate that no final summary line is printed.

CONTROL (HEADING('Start of Report')

FOOTING('End of Report')

SUMMARY('Final Summary Line')

,

field ,

.

.

.

)

Control Attr

specifies control information for the preceding control field.

ASCENDING | DESCENDING

specifies whether to sort the report records in ascending or descending order.

BREAK

specifies that a control break occurs when the value of the field changes. A control break also occurs for a field if a previously specified field has a control break. You can specify any number of control breaks.

HEADING

specifies the control break heading printed at the beginning of the control break when the value of the field changes. **HEADING** assumes the **BREAK** parameter.

One or more substitution variables can be specified for the control break footing. Any of the fields in the "REPORT VOLUME Statement Fields" section of *ExLM Quick Reference* can be specified by placing the ampersand character ("&") before the field and a period (".") after the field. The period is optional if the character immediately following the

field is not an alphanumeric or national character. For example, &DATASETNAME. substitutes the value of DATASETNAME each time a control break occurs.

text

specifies the text for control break heading. Each text string will be printed on a separate line. You can use a null text string to print a blank line.

FOOTING

specifies the control break footing printed at the end of the control break when the value of the field changes. FOOTING assumes the BREAK parameter.

One or more substitution variables can be specified for the control break footing. Any of the fields in the "REPORT VOLUME Statement Fields" section of *LCM Quick Reference* can be specified by placing the ampersand character ("&") before the field and a period (".") after the field. The period is optional if the character immediately following the field is not an alphanumeric or national character. For example, &DATASETNAME. substitutes the value of DATASETNAME each time a control break occurs.

text

specifies the text for control break footing. Each text string will be printed on a separate line. You can use a null text string to print a blank line.

PAGE

specifies that a page break occurs when the value of field changes. PAGE assumes the BREAK parameter.

One or more substitution variables can be specified for the control break footing. Any of the fields in the "REPORT VOLUME Statement Fields" section of *LCM Quick Reference* can be specified by placing the ampersand character ("&") before the field and a period (".") after the field. The period is optional if the character immediately following the field is not an alphanumeric or national character. For example, &DATASETNAME. substitutes the value of DATASETNAME at the beginning of a page break.

text

specifies the page break text. To print a blank line, use the null (") text string. This *text* parameter is optional.

The PAGE text and the Report volume title print on the same line. If you specify a long PAGE text string and there is not enough room for a centered Report title, the PAGE text overlays the Report title.

LIMIT

specifies the maximum number of volumes processed by this ACTION statement. The limit is applied based on the sort order established by the CONTROL parameter.

limit

specify a number between 1 and 999999.

NOLOG

specifies that LCM does not issue message LCM2317.

Usage

Use the ACTION RECLAIM statement to reclaim fragmented MVCs, optionally overriding the VTCS CONFIG RECLAIM settings for the THRSHLD, MAXMVC, and CONMVC parameters.

Example

The following ACTION RECLAIM statement reclaims MVCs in the LOCAL Storage Class:

```
ACTION NAME(RECLLOC) RECLAIM WHEN(MVCSTORCLAS EQ LOCAL);
```

ACTION RETURN

The ACTION RETURN statement has been replaced by ACTION VAULT RETURN; see [“ACTION VAULT RETURN” on page 267](#), but ACTION RETURN is still accepted if encountered.

ACTION SCRATCH

The ACTION SCRATCH statement scratches VTVs or Nearline volumes.

Syntax

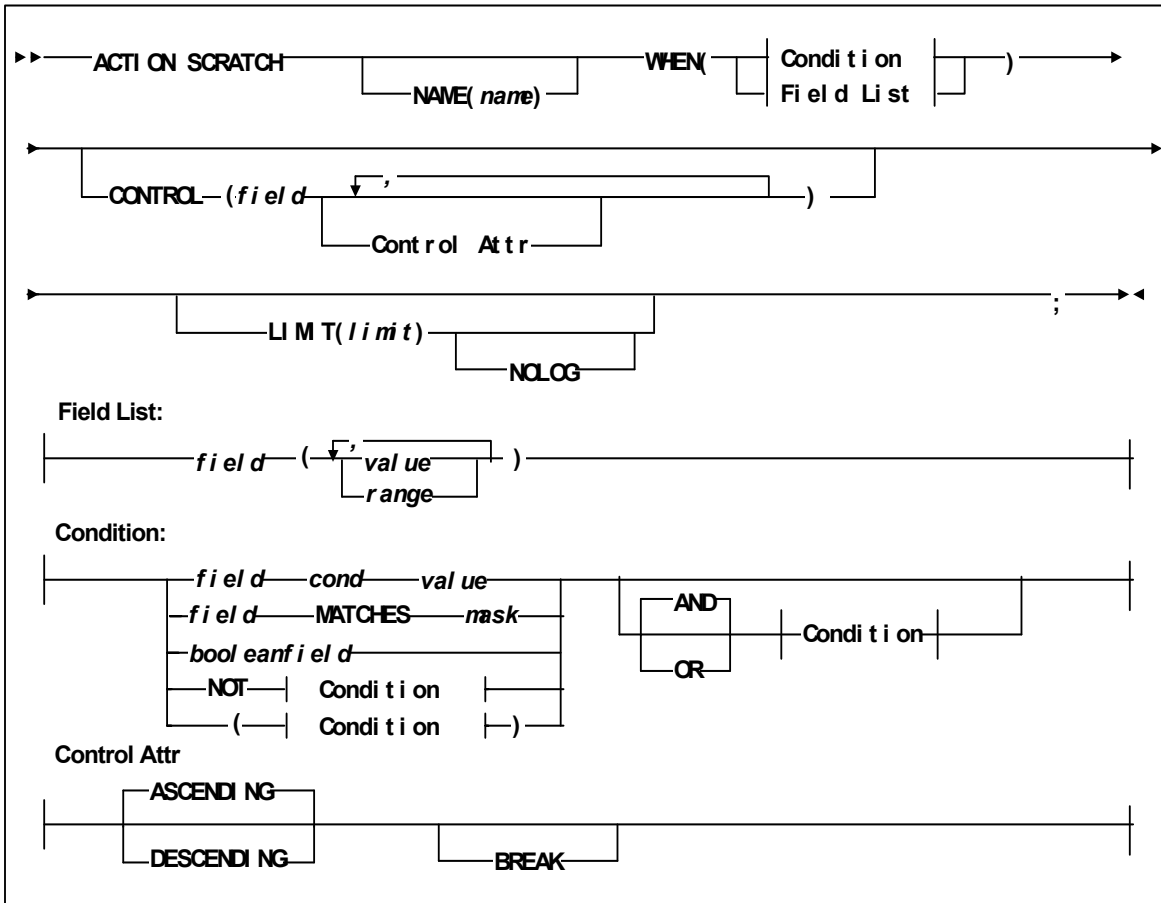

FIGURE 5-11 ACTION SCRATCH Statement Syntax

Parameters

NAME

specifies a unique name for this ACTION statement. The specified name appears in the Reason column of reports for volumes processed by this ACTION statement.

name

the 1 to 10 character name. The default is Action followed by the number of the ACTION statement.

WHEN(*condition*)

specifies one of the following for volume selection:

Field List

specifies the fields to use for volume selection. For a volume to be selected, the value for each *field* must match at least one of the provided *values* or *ranges*. The valid *values* depend on the type of *field* as described in [TABLE 5-1](#).

TABLE 5-25 Valid Types of Fields

Type	Values and Examples
Boolean	Specify TRUE or FALSE. FALSE is less than TRUE in comparisons.
Character or mixed character and integer string; also applies to ranges	Specify the string in single quotes. For example: WHEN(SERIAL('A00001')) WHEN(SERIAL('A00001'-'A99999'))
Date	Specify a date constant or MISSING. Date constants are of the form 'date'D or 'date'd where date can be specified in any date format defined in the "SET METHOD Statement WHEN Fields" section of <i>LCM Quick Reference</i> except TEXTDAYDATE. You must follow the format exactly. For example: '05Sep93'd is valid but '5Sep93'd is not.
Integer	Specify a number or MISSING. For example: 123
Time	Specify a time constant or MISSING. Time constants are of the form 'time'T where time can be specified in any time format defined in the "SET METHOD Statement WHEN Fields" section of <i>LCM Quick Reference</i> . You must follow the format exactly. For example: '12:30't is valid but '12;30't is not.

MISSING can also be specified as a period ("."). MISSING is less than all other values.

TABLE 5-26 Valid Formats for Date Fields

Type	Size	Example
yyddd	5	97248
ccyyddd	7	1997248
yy.ddd	6	97.248
ccyy.ddd	8	1997.248
mm/dd/yy	8	09/05/97
mm/dd/ccyy	10	09/05/1997

TABLE 5-26 Valid Formats for Date Fields

Type	Size	Example
yy-mm-dd	8	93-09-05
yyyy-mm-dd	10	2000-09-05 This is the default.
dd_mmm_yy	9	09 Sep 98
dd_mmm_ccyy	11	09 Sep 2000
ddmmmyy	7	09Sep98
ddmmccyy	9	09Sep1997
textdate	18	September 9, 2000
textdaydate	29	Wednesday, September 10, 2000

TABLE 5-27 Valid Formats for Time Fields

Type	Size	Example
hh:mm	5	22:21 This is the default.
hh:mm:ss	8	22:21:32
hh:mm:ss_pm	11	10:21:32 PM

Condition

specifies a condition for volume selection.

field cond value

specifies a field, a condition, and a value to compare with one of the following conditions:

EQ

equal to.

NE

not equal to.

GE

greater than or equal to.

GT

greater than.

LE

less than or equal to.

LT

less than.

For example, VOLSER GE A00243 selects volsers greater than or equal to A00243.

field MATCHES *mask*

specifies a field and a mask for selection. The valid masks depend on the field selected:

- DATASETNAME, BASENAME: Specify a string in single quotes. Wildcards can be used as follows:

“***” matches one or more data set qualifiers.

“*” matches one or more characters within a qualifier.

“%” matches one character within a qualifier.

- Other character fields: Specify a string in single quotes. Wildcards can be used as follows:

“*” matches one or more characters.

“%” matches one character.

For example, `DataSetName MATCHES DR*` selects all data sets with HLQs beginning with DR.

booleanfield

specifies a Boolean field to be tested for TRUE. Specify NOT before the field if you want to test for FALSE.

For example, `CLN` selects volumes that are cleaning cartridges.

NOT

reverses the condition that immediately follows the NOT keyword.

For example, `NOT CLN` selects volumes that are **not** cleaning cartridges.

AND

make the selection if both conditions are true.

For example, `NOT CLN AND SERIAL(A00500-A00750)` selects volumes A00500 through A00750 that are **not** cleaning cartridges.

OR

make the selection if either condition is true. For example, `NOT CLN OR SERIAL(A00500-A00750)` selects volumes A00500 through A00750 **or** volumes that are not cleaning cartridges.

Note – For complete information on the fields available, their types, values, and use, see *LCM Quick Reference*.

CONTROL

specifies the fields where breaks occur and the field sort order.

field

specifies a control field.

The volumes selected are sorted based on the control fields. You can use the `BREAK` subparameter to specify that a control break occurs when the value of a control field is different from the same field of the preceding volume.

You can specify the `HEADING`, `FOOTING`, and `SUMMARY | NOSUMMARY` subparameters before the first comma without coding a field name. This allows you to specify some text that is printed at the start of the report, at the end of the report, and just before the final summary line. Additionally, you can specify `NOSUMMARY` before the first comma to indicate that no final summary line is printed.

`CONTROL (HEADING('Start of Report')`

`FOOTING('End of Report')`

`SUMMARY('Final Summary Line')`

,
field ,

.
.
.

)

Control Attr

specifies control information for the preceding control field.

ASCENDING | DESCENDING

specifies whether to sort the report records in ascending or descending order.

BREAK

specifies that a control break occurs when the value of the field changes. A control break also occurs for a field if a previously specified field has a control break. You can specify any number of control breaks.

HEADING

specifies the control break heading printed at the beginning of the control break when the value of the field changes. **HEADING** assumes the **BREAK** parameter.

One or more substitution variables can be specified for the control break heading. Any of the fields in the "REPORT VOLUME Statement Fields" section of *ExLM Quick Reference* can be specified by placing the ampersand character ("&") before the field and a period (".") after the field. The period is optional if the character immediately following the field is not an alphanumeric or national character. For example, &DATASETNAME. substitutes the value of DATASETNAME each time a control break occurs.

text

specifies the text for control break heading. Each text string will be printed on a separate line. You can use a null text string to print a blank line.

FOOTING

specifies the control break footing printed at the end of the control break when the value of the field changes. **FOOTING** assumes the **BREAK** parameter.

One or more substitution variables can be specified for the control break footing. Any of the fields in the "REPORT VOLUME Statement Fields" section of *LCM Quick Reference* can be specified by placing the ampersand character ("&") before the field and a period (".") after the field. The period is optional if the character immediately following the field is not an alphanumeric or national character. For example, &DATASETNAME. substitutes the value of DATASETNAME each time a control break occurs.

text

specifies the text for control break footing. Each text string will be printed on a separate line. You can use a null text string to print a blank line.

PAGE

specifies that a page break occurs when the value of field changes. PAGE assumes the BREAK parameter.

One or more substitution variables can be specified for the control break footing. Any of the fields in the "REPORT VOLUME Statement Fields" section of *LCM Quick Reference* can be specified by placing the ampersand character ("&") before the field and a period (".") after the field. The period is optional if the character immediately following the field is not an alphanumeric or national character. For example, &DATASETNAME. substitutes the value of DATASETNAME at the beginning of a page break.

text

specifies the page break text. To print a blank line, use the null (") text string. This *text* parameter is optional.

The PAGE text and the Report volume title print on the same line. If you specify a long PAGE text string and there is not enough room for a centered Report title, the PAGE text overlays the Report title.

LIMIT

specifies the maximum number of volumes processed by this ACTION statement. The limit is applied based on the sort order established by the CONTROL parameter.

limit

specify a number between 1 and 999999.

NOLOG

specifies that LCM does not issue message LCM2317.

Usage

Use the ACTION SCRATCH statement to scratch VTVs or Nearline volumes.

Example

The following ACTION SCRATCH statement scratches volsers V0001 - V0009:
ACTION SCRATCH VOLSER(V0001-V0009);

ACTION UNSCRATCH

The ACTION UNSCRATCH statement unscratches VTVs or Nearline volumes.

Syntax

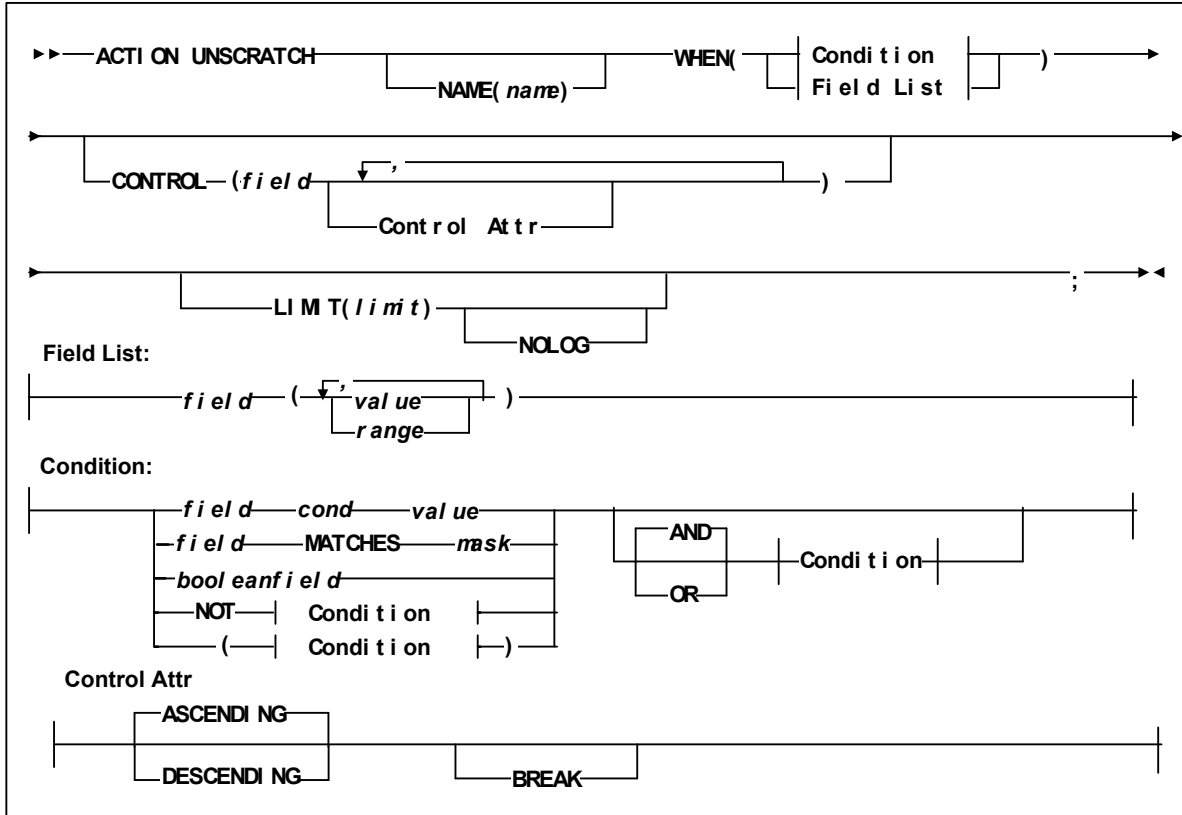

FIGURE 5-12 ACTION UNSCRATCH Statement Syntax

Parameters

NAME

specifies a unique name for this ACTION statement. The specified name appears in the Reason column of reports for volumes processed by this ACTION statement.

name

the 1 to 10 character name. The default is Action followed by the number of the ACTION statement.

WHEN(*condition*)

specifies one of the following for volume selection:

Field List

specifies the fields to use for volume selection. For a volume to be selected, the value for each *field* must match at least one of the provided *values* or *ranges*. The valid *values* depend on the type of *field* as described in [TABLE 5-1](#).

TABLE 5-28 Valid Types of Fields

Type	Values and Examples
Boolean	Specify TRUE or FALSE. FALSE is less than TRUE in comparisons.
Character or mixed character and integer string; also applies to ranges	Specify the string in single quotes. For example: WHEN(SERIAL('A00001')) WHEN(SERIAL('A00001'-'A99999'))
Date	Specify a date constant or MISSING. Date constants are of the form 'date'D or 'date'd where date can be specified in any date format defined in the "SET METHOD Statement WHEN Fields" section of <i>LCM Quick Reference</i> except TEXTDAYDATE. You must follow the format exactly. For example: '05Sep93'd is valid but '5Sep93'd is not.
Integer	Specify a number or MISSING. For example: 123
Time	Specify a time constant or MISSING. Time constants are of the form 'time'T where time can be specified in any time format defined in the "SET METHOD Statement WHEN Fields" section of <i>LCM Quick Reference</i> . You must follow the format exactly. For example: '12:30't is valid but '12;30't is not.

MISSING can also be specified as a period ("."). MISSING is less than all other values.

TABLE 5-29 Valid Formats for Date Fields

Type	Size	Example
yyddd	5	97248
ccyyddd	7	1997248
yy.ddd	6	97.248
ccyy.ddd	8	1997.248
mm/dd/yy	8	09/05/97
mm/dd/ccyy	10	09/05/1997

TABLE 5-29 Valid Formats for Date Fields

Type	Size	Example
yy-mm-dd	8	93-09-05
yyyy-mm-dd	10	2000-09-05 This is the default.
dd_mmm_yy	9	09 Sep 98
dd_mmm_ccyy	11	09 Sep 2000
ddmmmyy	7	09Sep98
ddmmccyy	9	09Sep1997
textdate	18	September 9, 2000
textdaydate	29	Wednesday, September 10, 2000

TABLE 5-30 Valid Formats for Time Fields

Type	Size	Example
hh:mm	5	22:21 This is the default.
hh:mm:ss	8	22:21:32
hh:mm:ss_pm	11	10:21:32 PM

Condition

specifies a condition for volume selection.

field cond value

specifies a field, a condition, and a value to compare with one of the following conditions:

EQ

equal to.

NE

not equal to.

GE

greater than or equal to.

GT

greater than.

LE

less than or equal to.

LT

less than.

For example, VOLSER GE A00243 selects volsers greater than or equal to A00243.

field MATCHES *mask*

specifies a field and a mask for selection. The valid masks depend on the field selected:

- DATASETNAME, BASENAME: Specify a string in single quotes. Wildcards can be used as follows:

“***” matches one or more data set qualifiers.

“*” matches one or more characters within a qualifier.

“%” matches one character within a qualifier.

- Other character fields: Specify a string in single quotes. Wildcards can be used as follows:

“*” matches one or more characters.

“%” matches one character.

For example, `DataSetName MATCHES DR*` selects all data sets with HLQs beginning with DR.

booleanfield

specifies a Boolean field to be tested for TRUE. Specify NOT before the field if you want to test for FALSE.

For example, `CLN` selects volumes that are cleaning cartridges.

NOT

reverses the condition that immediately follows the NOT keyword.

For example, `NOT CLN` selects volumes that are **not** cleaning cartridges.

AND

make the selection if both conditions are true.

For example, `NOT CLN AND SERIAL(A00500-A00750)` selects volumes A00500 through A00750 that are **not** cleaning cartridges.

OR

make the selection if either condition is true. For example, `NOT CLN OR SERIAL(A00500-A00750)` selects volumes A00500 through A00750 **or** volumes that are not cleaning cartridges.

Note – For complete information on the fields available, their types, values, and use, see *LCM Quick Reference*.

CONTROL

specifies the fields where breaks occur and the field sort order.

field

specifies a control field.

The volumes selected are sorted based on the control fields. You can use the BREAK subparameter to specify that a control break occurs when the value of a control field is different from the same field of the preceding volume.

You can specify the HEADING, FOOTING, and SUMMARY | NOSUMMARY subparameters before the first comma without coding a field name. This allows you to specify some text that is printed at the start of the report, at the end of the report, and just before the final summary line. Additionally, you can specify NOSUMMARY before the first comma to indicate that no final summary line is printed.

CONTROL (HEADING('Start of Report')

FOOTING('End of Report')

SUMMARY('Final Summary Line')

,
field ,

.
.
.

)

Control Attr

specifies control information for the preceding control field.

ASCENDING | DESCENDING

specifies whether to sort the report records in ascending or descending order.

BREAK

specifies that a control break occurs when the value of the field changes. A control break also occurs for a field if a previously specified field has a control break. You can specify any number of control breaks.

HEADING

specifies the control break heading printed at the beginning of the control break when the value of the field changes. **HEADING** assumes the **BREAK** parameter.

One or more substitution variables can be specified for the control break heading. Any of the fields in the "REPORT VOLUME Statement Fields" section of *ExLM Quick Reference* can be specified by placing the ampersand character ("&") before the field and a period (".") after the field. The period is optional if the character immediately following the field is not an alphanumeric or national character. For example, &DATASETNAME. substitutes the value of DATASETNAME each time a control break occurs.

text

specifies the text for control break heading. Each text string will be printed on a separate line. You can use a null text string to print a blank line.

FOOTING

specifies the control break footing printed at the end of the control break when the value of the field changes. **FOOTING** assumes the **BREAK** parameter.

One or more substitution variables can be specified for the control break footing. Any of the fields in the "REPORT VOLUME Statement Fields" section of *LCM Quick Reference* can be specified by placing the ampersand character ("&") before the field and a period (".") after the field. The period is optional if the character immediately following the field is not an alphanumeric or national character. For example, &DATASETNAME. substitutes the value of DATASETNAME each time a control break occurs.

text

specifies the text for control break footing. Each text string will be printed on a separate line. You can use a null text string to print a blank line.

PAGE

specifies that a page break occurs when the value of field changes. PAGE assumes the BREAK parameter.

One or more substitution variables can be specified for the control break footing. Any of the fields in the "REPORT VOLUME Statement Fields" section of *LCM Quick Reference* can be specified by placing the ampersand character ("&") before the field and a period (".") after the field. The period is optional if the character immediately following the field is not an alphanumeric or national character. For example, &DATASETNAME. substitutes the value of DATASETNAME at the beginning of a page break.

text

specifies the page break text. To print a blank line, use the null (") text string. This *text* parameter is optional.

The PAGE text and the Report volume title print on the same line. If you specify a long PAGE text string and there is not enough room for a centered Report title, the PAGE text overlays the Report title.

LIMIT

specifies the maximum number of volumes processed by this ACTION statement. The limit is applied based on the sort order established by the CONTROL parameter.

limit

specify a number between 1 and 999999.

NOLOG

specifies that LCM does not issue message LCM2317.

Usage

Use the ACTION UNSCRATCH statement to unscratch VTVs or Nearline volumes.

Example

The following ACTION UNSCRATCH statement unscratches volsers V0001 - V0009:
ACTION UNSCRATCH VOLSER(V0001-V0009);

ACTION VAULT ASSIGN

The ACTION VAULT ASSIGN statement assigns volumes to an ELS controlled vault.

Syntax

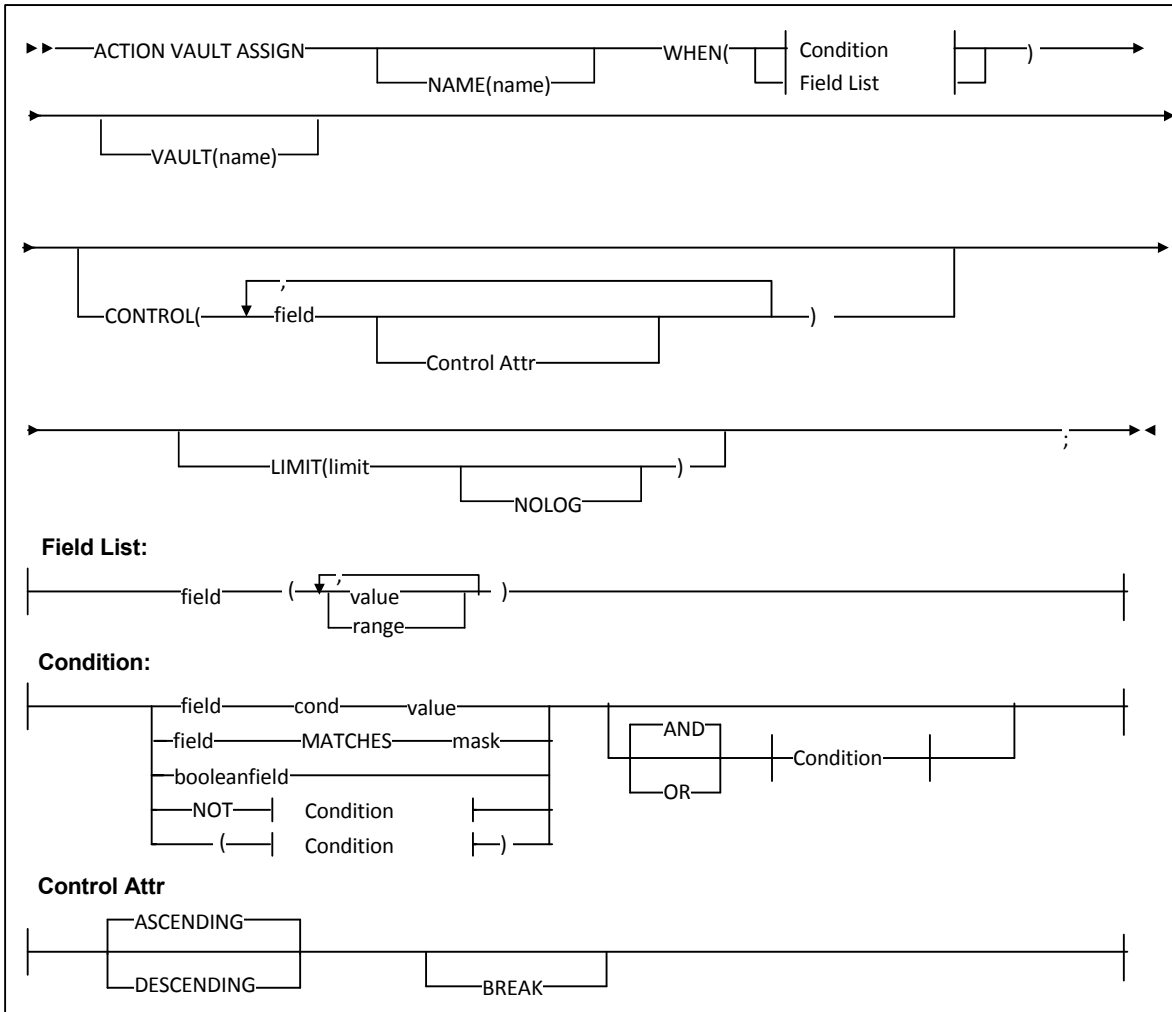

FIGURE 5-13 ACTION VAULT ASSIGN Statement Syntax

Parameters

NAME

specifies a unique name for this ACTION statement. The specified name appears in the Reason column of reports for volumes processed by this ACTION statement.

name

the 1 to 10 character name. The default is Action followed by the number of the ACTION statement.

VAULT

specifies the name of the ELS Vault to use.

name

The name of the vault, up to 8 characters. VAULT is a required keyword.

WHEN(*condition*)

specifies one of the following for volume selection:

Field List

specifies the fields to use for volume selection. For a volume to be selected, the value for each *field* must match at least one of the provided *values* or *ranges*.

The valid *values* depend on the type of *field* as described in [TABLE 5-1](#).

TABLE 5-31 Valid Types of Fields

Type	Values and Examples
Boolean	Specify TRUE or FALSE. FALSE is less than TRUE in comparisons.
Character or mixed character and integer string; also applies to ranges	Specify the string in single quotes. For example: WHEN(SERIAL('A00001')) WHEN(SERIAL('A00001'-'A99999'))
Date	Specify a date constant or MISSING. Date constants are of the form 'date'D or 'date'd where date can be specified in any date format defined in the "SET METHOD Statement WHEN Fields" section of <i>LCM Quick Reference</i> except TEXTDAYDATE. You must follow the format exactly. For example: '05Sep93'd is valid but '5Sep93'd is not.
Integer	Specify a number or MISSING. For example: 123
Time	Specify a time constant or MISSING. Time constants are of the form 'time'T where time can be specified in any time format defined in the "SET METHOD Statement WHEN Fields" section of <i>LCM Quick Reference</i> . You must follow the format exactly. For example: '12:30't is valid but '12;30't is not.

MISSING can also be specified as a period (“.”). MISSING is less than all other values.

TABLE 5-32 Valid Formats for Date Fields

Type	Size	Example
yyddd	5	97248
ccyyddd	7	1997248
yy.ddd	6	97.248
ccyy.ddd	8	1997.248
mm/dd/yy	8	09/05/97
mm/dd/ccyy	10	09/05/1997
yy-mm-dd	8	93-09-05
yyyy-mm-dd	10	2000-09-05 This is the default.
dd_mmm_yy	9	09 Sep 98
dd_mmm_ccyy	11	09 Sep 2000
ddmmmyy	7	09Sep98
ddmmccyy	9	09Sep1997
textdate	18	September 9, 2000
textdaydate	29	Wednesday, September 10, 2000

TABLE 5-33 Valid Formats for Time Fields

Type	Size	Example
hh:mm	5	22:21 This is the default.
hh:mm:ss	8	22:21:32
hh:mm:ss_pm	11	10:21:32 PM

Condition

specifies a condition for volume selection.

field cond value

specifies a field, a condition, and a value to compare with one of the following conditions:

EQ

equal to.

NE

not equal to.

GE

greater than or equal to.

GT

greater than.

LE

less than or equal to.

LT

less than.

For example, `VOLSER GE A00243` selects volsers greater than or equal to A00243.

field MATCHES *mask*

specifies a field and a mask for selection. The valid masks depend on the field selected:

■ **DATASETNAME, BASENAME:** Specify a string in single quotes. Wildcards can be used as follows:

“***” matches one or more data set qualifiers.

“*” matches one or more characters within a qualifier.

“%” matches one character within a qualifier.

■ **Other character fields:** Specify a string in single quotes. Wildcards can be used as follows:

“*” matches one or more characters.

“%” matches one character.

For example, `DataSetName MATCHES DR*` selects all data sets with HLQs beginning with DR.

booleanfield

specifies a Boolean field to be tested for TRUE. Specify NOT before the field if you want to test for FALSE.

For example, `CLN` selects volumes that are cleaning cartridges.

NOT

reverses the condition that immediately follows the NOT keyword.

For example, `NOT CLN` selects volumes that are **not** cleaning cartridges.

AND

make the selection if both conditions are true.

For example, `NOT CLN AND SERIAL(A00500-A00750)` selects volumes A00500 through A00750 that are **not** cleaning cartridges.

OR

make the selection if either condition is true. For example, `NOT CLN OR SERIAL(A00500-A00750)` selects volumes A00500 through A00750 **or** volumes that are not cleaning cartridges.

Note – For complete information on the fields available, their types, values, and use, see *LCM Quick Reference*.

CONTROL

specifies the fields where breaks occur and the field sort order.

field

specifies a control field.

The volumes selected are sorted based on the control fields. You can use the **BREAK** subparameter to specify that a control break occurs when the value of a control field is different from the same field of the preceding volume.

You can specify the **HEADING**, **FOOTING**, and **SUMMARY | NOSUMMARY** subparameters before the first comma without coding a field name. This allows you to specify some text that is printed at the start of the report, at the end of the report, and just before the final summary line. Additionally, you can specify **NOSUMMARY** before the first comma to indicate that no final summary line is printed.

CONTROL (HEADING('Start of Report')

FOOTING('End of Report')

SUMMARY('Final Summary Line')

**,
field ,**

**.
. .
.**

)

Control Attr

specifies control information for the preceding control field.

ASCENDING | DESCENDING

specifies whether to sort the report records in ascending or descending order.

BREAK

specifies that a control break occurs when the value of the field changes. A control break also occurs for a field if a previously specified field has a control break. You can specify any number of control breaks.

HEADING

specifies the control break heading printed at the beginning of the control break when the value of the field changes. **HEADING** assumes the **BREAK** parameter.

One or more substitution variables can be specified for the control break heading. Any of the fields in the "REPORT VOLUME Statement Fields" section of *ExLM Quick Reference* can be specified by placing the ampersand character ("&") before the field and a period (".") after the field. The period is optional if the character immediately following the field is not an alphanumeric or national character. For example, **&DATASETNAME.** substitutes the value of **DATASETNAME** each time a control break occurs.

text

specifies the text for control break heading. Each text string will be printed on a separate line. You can use a null text string to print a blank line.

FOOTING

specifies the control break footing printed at the end of the control break when the value of the field changes. FOOTING assumes the BREAK parameter.

One or more substitution variables can be specified for the control break footing. Any of the fields in the "REPORT VOLUME Statement Fields" section of *LCM Quick Reference* can be specified by placing the ampersand character ("&") before the field and a period (".") after the field. The period is optional if the character immediately following the field is not an alphanumeric or national character. For example, &DATASETNAME. substitutes the value of DATASETNAME each time a control break occurs.

text

specifies the text for control break footing. Each text string will be printed on a separate line. You can use a null text string to print a blank line.

PAGE

specifies that a page break occurs when the value of field changes. PAGE assumes the BREAK parameter.

One or more substitution variables can be specified for the control break footing. Any of the fields in the "REPORT VOLUME Statement Fields" section of *LCM Quick Reference* can be specified by placing the ampersand character ("&") before the field and a period (".") after the field. The period is optional if the character immediately following the field is not an alphanumeric or national character. For example, &DATASETNAME. substitutes the value of DATASETNAME at the beginning of a page break.

text

specifies the page break text. To print a blank line, use the null (") text string. This *text* parameter is optional.

The PAGE text and the Report volume title print on the same line. If you specify a long PAGE text string and there is not enough room for a centered Report title, the PAGE text overlays the Report title.

RECALWER

specifies whether VTCS recalls VTVs with read data checks.

YES

recall VTVs with read data checks (the default).

NO

do not recall VTVs with read data checks.

LIMIT

specifies the maximum number of volumes processed by this ACTION statement. The limit is applied based on the sort order established by the CONTROL parameter.

limit

specify a number between 1 and 999999.

NOLOG

specifies that LCM does not issue message LCM2317.

Usage

For more information, see *ELS Disaster Recovery and Offsite Data Management Guide*.

ACTION VAULT RELEASE

The ACTION VAULT RELEASE statement removes volumes from an ELS controlled vault..

Syntax

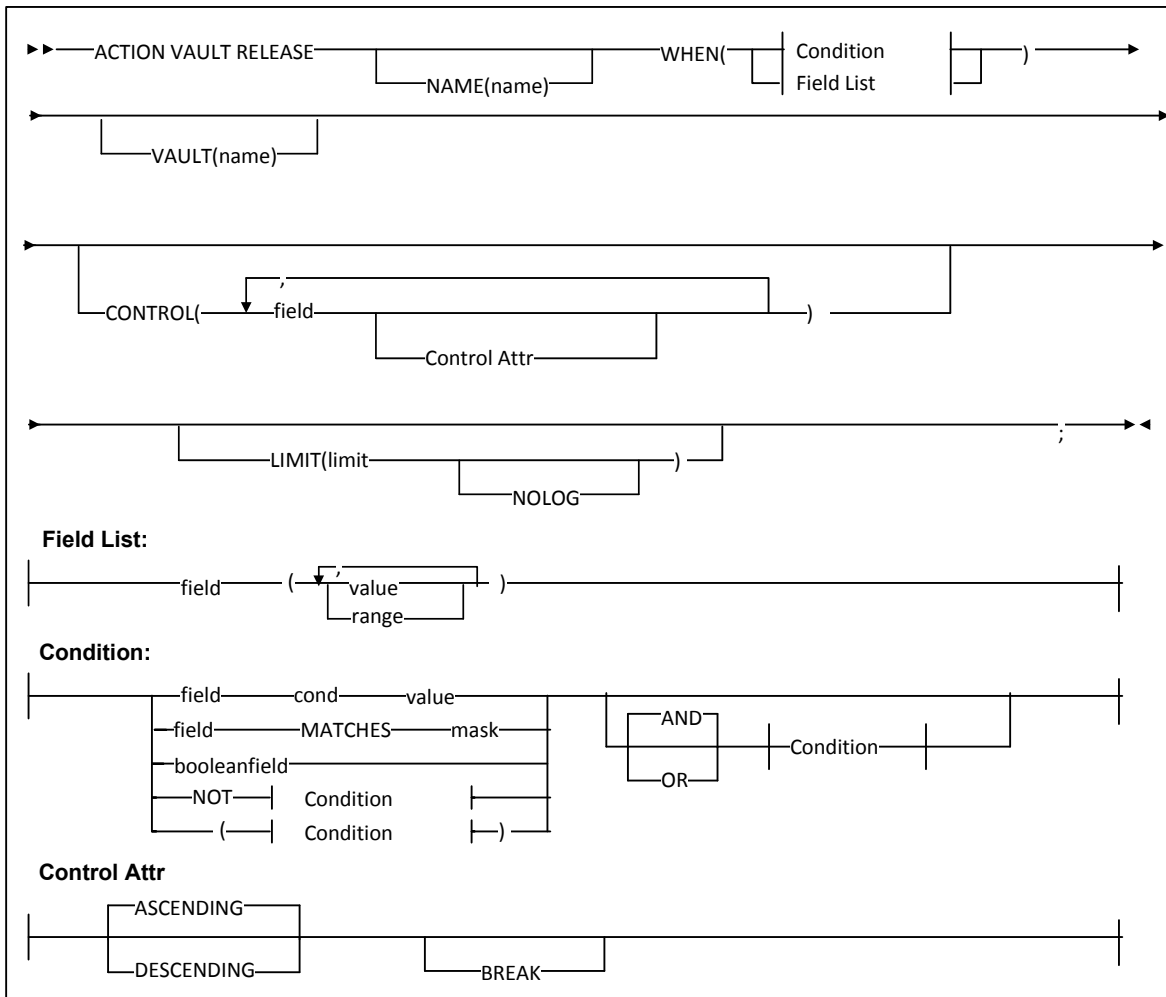

FIGURE 5-14 ACTION VAULT RELEASE Statement Syntax

Parameters

NAME

specifies a unique name for this ACTION statement. The specified name appears in the Reason column of reports for volumes processed by this ACTION statement.

name

the 1 to 10 character name. The default is Action followed by the number of the ACTION statement.

VAULT

specifies the name of the ELS Vault to use.

name

The name of the vault, up to 8 characters. VAULT is a required keyword.

WHEN(*condition*)

specifies one of the following for volume selection:

Field List

specifies the fields to use for volume selection. For a volume to be selected, the value for each *field* must match at least one of the provided *values* or *ranges*. The valid *values* depend on the type of *field* as described in [TABLE 5-1](#).

TABLE 5-34 Valid Types of Fields

Type	Values and Examples
Boolean	Specify TRUE or FALSE. FALSE is less than TRUE in comparisons.
Character or mixed character and integer string; also applies to ranges	Specify the string in single quotes. For example: WHEN(SERIAL('A00001')) WHEN(SERIAL('A00001'-'A99999'))
Date	Specify a date constant or MISSING. Date constants are of the form 'date'D or 'date'd where date can be specified in any date format defined in the "SET METHOD Statement WHEN Fields" section of <i>LCM Quick Reference</i> except TEXTDAYDATE. You must follow the format exactly. For example: '05Sep93'd is valid but '5Sep93'd is not.
Integer	Specify a number or MISSING. For example: 123
Time	Specify a time constant or MISSING. Time constants are of the form 'time'T where time can be specified in any time format defined in the "SET METHOD Statement WHEN Fields" section of <i>LCM Quick Reference</i> . You must follow the format exactly. For example: '12:30't is valid but '12;30't is not.

MISSING can also be specified as a period (“.”). MISSING is less than all other values.

TABLE 5-35 Valid Formats for Date Fields

Type	Size	Example
yyddd	5	97248
ccyyddd	7	1997248
yy.ddd	6	97.248
ccyy.ddd	8	1997.248
mm/dd/yy	8	09/05/97
mm/dd/ccyy	10	09/05/1997
yy-mm-dd	8	93-09-05
yyyy-mm-dd	10	2000-09-05 This is the default.
dd_mmm_yy	9	09 Sep 98
dd_mmm_ccyy	11	09 Sep 2000
ddmmmyy	7	09Sep98
ddmmccyy	9	09Sep1997
textdate	18	September 9, 2000
textdaydate	29	Wednesday, September 10, 2000

TABLE 5-36 Valid Formats for Time Fields

Type	Size	Example
hh:mm	5	22:21 This is the default.
hh:mm:ss	8	22:21:32
hh:mm:ss_pm	11	10:21:32 PM

Condition

specifies a condition for volume selection.

field cond value

specifies a field, a condition, and a value to compare with one of the following conditions:

EQ

equal to.

NE

not equal to.

GE

greater than or equal to.

GT

greater than.

LE

less than or equal to.

LT

less than.

For example, `VOLSER GE A00243` selects volsers greater than or equal to A00243.

field **MATCHES** *mask*

specifies a field and a mask for selection. The valid masks depend on the field selected:

■ **DATASETNAME, BASENAME:** Specify a string in single quotes. Wildcards can be used as follows:

“***” matches one or more data set qualifiers.

“*” matches one or more characters within a qualifier.

“%” matches one character within a qualifier.

■ **Other character fields:** Specify a string in single quotes. Wildcards can be used as follows:

“*” matches one or more characters.

“%” matches one character.

For example, `DataSetName MATCHES DR*` selects all data sets with HLQs beginning with DR.

booleanfield

specifies a Boolean field to be tested for TRUE. Specify NOT before the field if you want to test for FALSE.

For example, `CLN` selects volumes that are cleaning cartridges.

NOT

reverses the condition that immediately follows the NOT keyword.

For example, `NOT CLN` selects volumes that are **not** cleaning cartridges.

AND

make the selection if both conditions are true.

For example, `NOT CLN AND SERIAL(A00500-A00750)` selects volumes A00500 through A00750 that are **not** cleaning cartridges.

OR

make the selection if either condition is true. For example, `NOT CLN OR SERIAL(A00500-A00750)` selects volumes A00500 through A00750 **or** volumes that are not cleaning cartridges.

Note – For complete information on the fields available, their types, values, and use, see *LCM Quick Reference*.

CONTROL

specifies the fields where breaks occur and the field sort order.

field

specifies a control field.

The volumes selected are sorted based on the control fields. You can use the **BREAK** subparameter to specify that a control break occurs when the value of a control field is different from the same field of the preceding volume.

You can specify the **HEADING**, **FOOTING**, and **SUMMARY | NOSUMMARY** subparameters before the first comma without coding a field name. This allows you to specify some text that is printed at the start of the report, at the end of the report, and just before the final summary line. Additionally, you can specify **NOSUMMARY** before the first comma to indicate that no final summary line is printed.

CONTROL (HEADING('Start of Report')

FOOTING('End of Report')

SUMMARY('Final Summary Line')

,
field ,

.
.
.

)

Control Attr

specifies control information for the preceding control field.

ASCENDING | DESCENDING

specifies whether to sort the report records in ascending or descending order.

BREAK

specifies that a control break occurs when the value of the field changes. A control break also occurs for a field if a previously specified field has a control break. You can specify any number of control breaks.

HEADING

specifies the control break heading printed at the beginning of the control break when the value of the field changes. **HEADING** assumes the **BREAK** parameter.

One or more substitution variables can be specified for the control break heading. Any of the fields in the "REPORT VOLUME Statement Fields" section of *ExLM Quick Reference* can be specified by placing the ampersand character ("&") before the field and a period (".") after the field. The period is optional if the character immediately following the field is not an alphanumeric or national character. For example, **&DATASETNAME.** substitutes the value of **DATASETNAME** each time a control break occurs.

text

specifies the text for control break heading. Each text string will be printed on a separate line. You can use a null text string to print a blank line.

FOOTING

specifies the control break footing printed at the end of the control break when the value of the field changes. FOOTING assumes the BREAK parameter.

One or more substitution variables can be specified for the control break footing. Any of the fields in the "REPORT VOLUME Statement Fields" section of *LCM Quick Reference* can be specified by placing the ampersand character ("&") before the field and a period (".") after the field. The period is optional if the character immediately following the field is not an alphanumeric or national character. For example, &DATASETNAME. substitutes the value of DATASETNAME each time a control break occurs.

text

specifies the text for control break footing. Each text string will be printed on a separate line. You can use a null text string to print a blank line.

PAGE

specifies that a page break occurs when the value of field changes. PAGE assumes the BREAK parameter.

One or more substitution variables can be specified for the control break footing. Any of the fields in the "REPORT VOLUME Statement Fields" section of *LCM Quick Reference* can be specified by placing the ampersand character ("&") before the field and a period (".") after the field. The period is optional if the character immediately following the field is not an alphanumeric or national character. For example, &DATASETNAME. substitutes the value of DATASETNAME at the beginning of a page break.

text

specifies the page break text. To print a blank line, use the null (") text string. This *text* parameter is optional.

The PAGE text and the Report volume title print on the same line. If you specify a long PAGE text string and there is not enough room for a centered Report title, the PAGE text overlays the Report title.

RECALWER

specifies whether VTCS recalls VTVs with read data checks.

YES

recall VTVs with read data checks (the default).

NO

do not recall VTVs with read data checks.

LIMIT

specifies the maximum number of volumes processed by this ACTION statement. The limit is applied based on the sort order established by the CONTROL parameter.

limit

specify a number between 1 and 999999.

NOLOG

specifies that LCM does not issue message LCM2317.

Usage

For more information, see *ELS Disaster Recovery and Offsite Data Management Guide*.

ACTION VAULT RETURN

The ACTION VAULT RETURN statement sets the RETURN date for volumes in ELS controlled vaults per the return date specified in the associated VAULT statements in this run.

Syntax

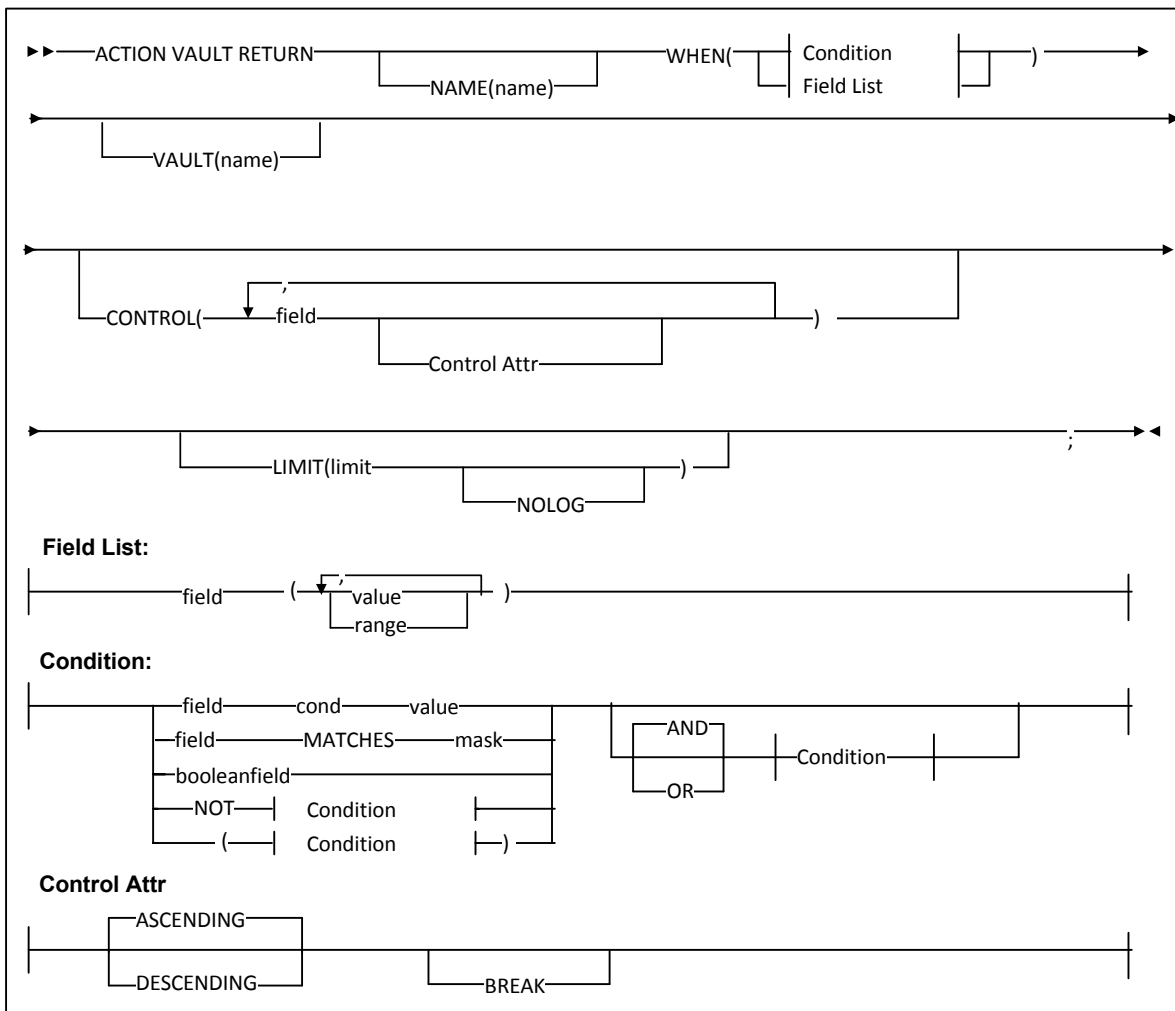

FIGURE 5-15 ACTION VAULT RETURN Statement Syntax

Parameters

NAME

specifies a unique name for this ACTION statement. The specified name appears in the Reason column of reports for volumes processed by this ACTION statement.

name

the 1 to 10 character name. The default is Action followed by the number of the ACTION statement.

VAULT

specifies the name of the ELS Vault to use.

name

The name of the vault, up to 8 characters. VAULT is a required keyword.

WHEN(*condition*)

specifies one of the following for volume selection:

Field List

specifies the fields to use for volume selection. For a volume to be selected, the value for each *field* must match at least one of the provided *values* or *ranges*.

The valid *values* depend on the type of *field* as described in [TABLE 5-1](#).

TABLE 5-37 Valid Types of Fields

Type	Values and Examples
Boolean	Specify TRUE or FALSE. FALSE is less than TRUE in comparisons.
Character or mixed character and integer string; also applies to ranges	Specify the string in single quotes. For example: WHEN(SERIAL('A00001')) WHEN(SERIAL('A00001'-'A99999'))
Date	Specify a date constant or MISSING. Date constants are of the form 'date'D or 'date'd where date can be specified in any date format defined in the "SET METHOD Statement WHEN Fields" section of <i>LCM Quick Reference</i> except TEXTDAYDATE. You must follow the format exactly. For example: '05Sep93'd is valid but '5Sep93'd is not.
Integer	Specify a number or MISSING. For example: 123
Time	Specify a time constant or MISSING. Time constants are of the form 'time'T where time can be specified in any time format defined in the "SET METHOD Statement WHEN Fields" section of <i>LCM Quick Reference</i> . You must follow the format exactly. For example: '12:30't is valid but '12;30't is not.

MISSING can also be specified as a period (“.”). MISSING is less than all other values.

TABLE 5-38 Valid Formats for Date Fields

Type	Size	Example
yyddd	5	97248
ccyyddd	7	1997248
yy.ddd	6	97.248
ccyy.ddd	8	1997.248
mm/dd/yy	8	09/05/97
mm/dd/ccyy	10	09/05/1997
yy-mm-dd	8	93-09-05
yyyy-mm-dd	10	2000-09-05 This is the default.
dd_mmm_yy	9	09 Sep 98
dd_mmm_ccyy	11	09 Sep 2000
ddmmmyy	7	09Sep98
ddmmccyy	9	09Sep1997
textdate	18	September 9, 2000
textdaydate	29	Wednesday, September 10, 2000

TABLE 5-39 Valid Formats for Time Fields

Type	Size	Example
hh:mm	5	22:21 This is the default.
hh:mm:ss	8	22:21:32
hh:mm:ss_pm	11	10:21:32 PM

Condition

specifies a condition for volume selection.

field cond value

specifies a field, a condition, and a value to compare with one of the following conditions:

EQ

equal to.

NE

not equal to.

GE

greater than or equal to.

GT

greater than.

LE

less than or equal to.

LT

less than.

For example, `VOLSER GE A00243` selects volsers greater than or equal to A00243.

field MATCHES *mask*

specifies a field and a mask for selection. The valid masks depend on the field selected:

■ **DATASETNAME, BASENAME:** Specify a string in single quotes. Wildcards can be used as follows:

“***” matches one or more data set qualifiers.

“*” matches one or more characters within a qualifier.

“%” matches one character within a qualifier.

■ **Other character fields:** Specify a string in single quotes. Wildcards can be used as follows:

“*” matches one or more characters.

“%” matches one character.

For example, `DataSetName MATCHES DR*` selects all data sets with HLQs beginning with DR.

booleanfield

specifies a Boolean field to be tested for TRUE. Specify NOT before the field if you want to test for FALSE.

For example, `CLN` selects volumes that are cleaning cartridges.

NOT

reverses the condition that immediately follows the NOT keyword.

For example, `NOT CLN` selects volumes that are **not** cleaning cartridges.

AND

make the selection if both conditions are true.

For example, `NOT CLN AND SERIAL(A00500-A00750)` selects volumes A00500 through A00750 that are **not** cleaning cartridges.

OR

make the selection if either condition is true. For example, `NOT CLN OR SERIAL(A00500-A00750)` selects volumes A00500 through A00750 **or** volumes that are not cleaning cartridges.

Note – For complete information on the fields available, their types, values, and use, see *LCM Quick Reference*.

CONTROL

specifies the fields where breaks occur and the field sort order.

field

specifies a control field.

The volumes selected are sorted based on the control fields. You can use the **BREAK** subparameter to specify that a control break occurs when the value of a control field is different from the same field of the preceding volume.

You can specify the **HEADING**, **FOOTING**, and **SUMMARY | NOSUMMARY** subparameters before the first comma without coding a field name. This allows you to specify some text that is printed at the start of the report, at the end of the report, and just before the final summary line. Additionally, you can specify **NOSUMMARY** before the first comma to indicate that no final summary line is printed.

CONTROL (HEADING('Start of Report')

FOOTING('End of Report')

SUMMARY('Final Summary Line')

,
field ,

.
.
.

)

Control Attr

specifies control information for the preceding control field.

ASCENDING | DESCENDING

specifies whether to sort the report records in ascending or descending order.

BREAK

specifies that a control break occurs when the value of the field changes. A control break also occurs for a field if a previously specified field has a control break. You can specify any number of control breaks.

HEADING

specifies the control break heading printed at the beginning of the control break when the value of the field changes. **HEADING** assumes the **BREAK** parameter.

One or more substitution variables can be specified for the control break heading. Any of the fields in the "REPORT VOLUME Statement Fields" section of *ExLM Quick Reference* can be specified by placing the ampersand character ("&") before the field and a period (".") after the field. The period is optional if the character immediately following the field is not an alphanumeric or national character. For example, **&DATASETNAME.** substitutes the value of **DATASETNAME** each time a control break occurs.

text

specifies the text for control break heading. Each text string will be printed on a separate line. You can use a null text string to print a blank line.

FOOTING

specifies the control break footing printed at the end of the control break when the value of the field changes. FOOTING assumes the BREAK parameter.

One or more substitution variables can be specified for the control break footing. Any of the fields in the "REPORT VOLUME Statement Fields" section of *LCM Quick Reference* can be specified by placing the ampersand character ("&") before the field and a period (".") after the field. The period is optional if the character immediately following the field is not an alphanumeric or national character. For example, &DATASETNAME. substitutes the value of DATASETNAME each time a control break occurs.

text

specifies the text for control break footing. Each text string will be printed on a separate line. You can use a null text string to print a blank line.

PAGE

specifies that a page break occurs when the value of field changes. PAGE assumes the BREAK parameter.

One or more substitution variables can be specified for the control break footing. Any of the fields in the "REPORT VOLUME Statement Fields" section of *LCM Quick Reference* can be specified by placing the ampersand character ("&") before the field and a period (".") after the field. The period is optional if the character immediately following the field is not an alphanumeric or national character. For example, &DATASETNAME. substitutes the value of DATASETNAME at the beginning of a page break.

text

specifies the page break text. To print a blank line, use the null (") text string. This *text* parameter is optional.

The PAGE text and the Report volume title print on the same line. If you specify a long PAGE text string and there is not enough room for a centered Report title, the PAGE text overlays the Report title.

RECALWER

specifies whether VTCS recalls VTVs with read data checks.

YES

recall VTVs with read data checks (the default).

NO

do not recall VTVs with read data checks.

LIMIT

specifies the maximum number of volumes processed by this ACTION statement. The limit is applied based on the sort order established by the CONTROL parameter.

limit

specify a number between 1 and 999999.

NOLOG

specifies that LCM does not issue message LCM2317.

Usage

For more information, see *ELS Disaster Recovery and Offsite Data Management Guide*.

LCM Reports Control Statements

LCM provides the following types of reports:

- [“Standard Reports” on page 276](#)
- [“Optional Reports” on page 320](#)
- [“Custom Reports” on page 353](#)

Standard Reports

LCM automatically generates fixed-content Standard Reports unless suppressed via the `OPTIONS SUPAUTORPT` parameter.

REPORT CELLCNT

The REPORT CELLCNT statement specifies options for a Cell Count Report.

Syntax

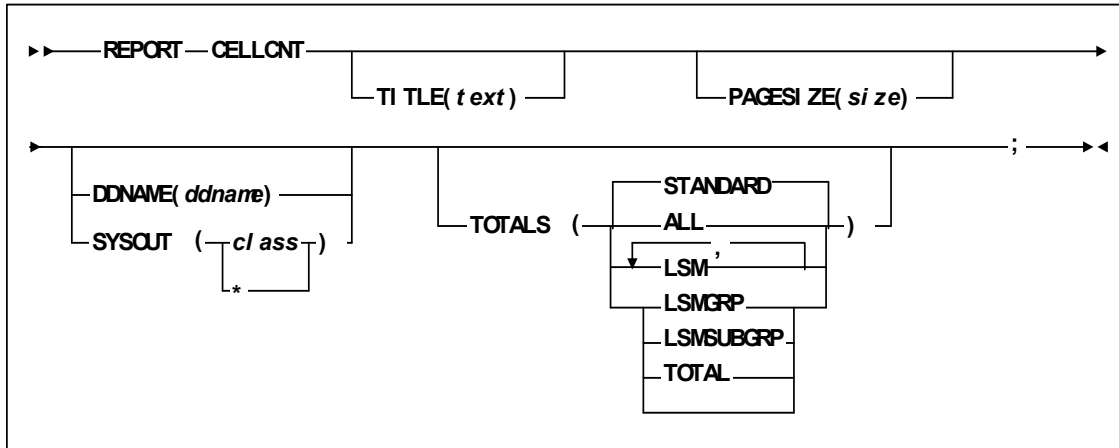

FIGURE 6-1 REPORT CELLCNT Statement Syntax

Parameters

TABLE 6-1 lists the valid abbreviations for the REPORT CELLCNT statement.

TABLE 6-1 REPORT CELLCNT Statement Abbreviations

Statement or Parameter	Abbreviation
REPORT	RPT
CELLCNT	CC
DDNAME	DD,DDN

TITLE

specifies the title on each page of the report. The TITLE parameter of the OPTIONS statement defines a main title to be printed in the report headings. The title specified by the TITLE parameter of a REPORT statement is printed below this main title.

If you do not specify TITLE, the title is "Cell Count Report".

text

the title, which is a maximum of 70 characters.

PAGESIZE

specifies the maximum lines per page for printing the report.

size

the maximum lines per page. Valid values are 20 to 1000. You can specify a default pagesize for all reports on the LCM main program JCL EXEC statement. Otherwise, the default is 58.

Note – You must specify the same lines per page for all reports written to the same ddname.

DDNAME

specifies the ddname where LCM writes the report.

DDNAME and SYSOUT are mutually exclusive. If you specify neither, LCM writes the report to DDNAME(SYSPRINT).

ddname

the ddname.

SYSOUT

specifies that LCM writes the report to the specified SYSOUT class.

DDNAME and SYSOUT are mutually exclusive. If you specify neither, LCM writes the report to DDNAME(SYSPRINT).

class

the SYSOUT class: A through Z or 0 through 9 or * for the default output class for the job.

TOTALS

specifies the type of total lines for the *Cell Count Report*.

If you do not specify the TOTALS parameter, the default is STANDARD.

ALL

all types of totals.

LSM

totals for each LSM.

LSMGRP

totals for each LSM group.

LSMSUBGRP

totals for each LSM subgroup.

STANDARD

LCM selects totals.

TOTAL

grand totals.

Usage

Use the REPORT CELLCNT statement to specify options for a Cell Count Report, which displays cells and volume information for each LSM that LCM manages.

Cell Count Report

FIGURE 6-2 shows an example of a Cell Count Report.

2012-07-04 13:37:07		StorageTek Library Content Manager 72												PAGE 5			
Daily Vaulting Run																	
Cell Count Report														CELLCNT			
Projected Cell Use:	-Free Cells-		-Scratch-	-CLN-	-MVC-		----	Not Pickable	----	Pickable by Order					----	-Frozen-	-Total-
	Init	Proj	Proj	Proj	Free	In- Use				1-20	21-40	41-60	61-80	81-100	Empty		
LSM 00:00	1444	1400	1500	6	106	102		0		0	0	2255	0	0	0	0	5335
LSM 00:01	137	200	811	6	92	104		0		0	0	2066	0	0	0	357	5577
Total	1581	1600	2311	12	198	206		0		0	0	4321	0	0	0	357	10912

FIGURE 6-2 Cell Count Report

The following list describes the Cell Count Report fields.

Free Cells

the initial and projected number of free cells.

Scratch

the projected number of scratch volumes.

CLN

the projected number of cleaning cartridges.

MVC

the number of free and in-use MVCs.

Not Pickable

the projected number of volumes that are ineligible for ejection or demotion after this LCM run, based on the supplied parameter file.

Pickable by Order

the projected number of volumes that are pickable for ejection or demotion after this LCM run, based on the supplied parameter file. The counts are broken down into ranges by pick order, which is determined by the ORDER attribute of a management method; for more information, see ["METHOD" on page 106](#).

Misc

the projected number of volumes that do not fit in any of the other columns on this report. This field includes BadScratch volumes and cleaning cartridges HSC has marked not usable.

Frozen Empty

the projected number of empty cells on frozen panels. LCM does not consider these free cells because they are not available for use.

Total Cells

the total number of cells.

REPORT CONSOLIDATE

The REPORT CONSOLIDATE statement specifies options for a Consolidation Report. If an automatic Consolidation Report is printed, it uses the default options.

Syntax

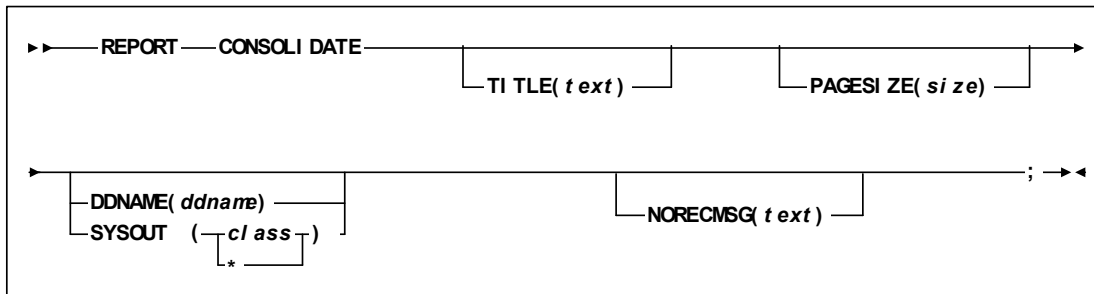

FIGURE 6-3 REPORT CONSOLIDATE Statement Syntax

Parameters

TABLE 6-2 lists the valid abbreviations for the REPORT CONSOLIDATE statement.

TABLE 6-2 REPORT CONSOLIDATE Statement Abbreviations

Statement or Parameter	Abbreviation
REPORT	RPT
CONSOLIDATE	CONS
DDNAME	DD,DDN

TITLE

specifies the title on each page of the report. The TITLE parameter of the OPTIONS statement defines a main title to be printed in the report headings. The title specified by the TITLE parameter of a REPORT statement is printed below this main title.

If you do not specify TITLE, the title is "Cell Count Report".

text

the title, which is a maximum of 70 characters.

PAGESIZE

specifies the maximum lines per page for printing the report.

size

the maximum lines per page. Valid values are 20 to 1000. You can specify a default pagesize for all reports on the ExLM main program JCL EXEC statement. Otherwise, the default is 58.

Note – You must specify the same lines per page for all reports written to the same ddname.

DDNAME

specifies the ddname where ExLM writes the report.

DDNAME and SYSOUT are mutually exclusive. If you specify neither, ExLM writes the report to DDNAME(SYSPRINT).

ddname

the ddname.

SYSOUT

specifies that ExLM writes the report to the specified SYSOUT class.

DDNAME and SYSOUT are mutually exclusive. If you specify neither, ExLM writes the report to DDNAME(SYSPRINT).

class

the SYSOUT class: A through Z or 0 through 9 or * for the default output class for the job.

NORECMMSG

specifies the text to print if no records are printed on the report. The specified text prints where the first record would appear.

text

specifies the text to print, which is a maximum of 70 characters. The default text is 'No records to print for this report.'

Note – If you explicitly code a statement for this report, it is **always** printed, even if there are no records to print.

Usage

Use the REPORT CONSOLIDATE statement to specify options for a Consolidation Report, which displays volume and method information for VTV consolidations.

Consolidation Report

FIGURE 6-4 shows an example Consolidation Report.

2012-06-03 13:37:22			StorageTek Library Content Manager 7.2			PAGE 3		
Consolidation Group CONSGRP1			LCM Daily Run Consolidation Report			CONSOLIDAT E		
VTV	Method	Reason	VTV	Method	Reason	VTV	Method	Reason
H01356	Action	Action/8	C02569	Cons1	Location	C02248	Cons1	Location
A00159	Action	Action/8	C02688	Cons2	Location	C02689	Cons1	Location
A00287	Action	Action/8	C02727	Cons2	Location	C02244	Cons2	Location
*A00541	Cons3	Set Method	C02965	Cons2	Location	C02748	Cons2	Location
A01117	Cons3	Set Method	C03127	Cons2	Location	C02008	Cons2	Location
A01748	Cons3	Set Method	C03136	Cons2	Location	C02200	Cons2	Location
Note: "*" indicates a consolidation break.								

FIGURE 6-4 Consolidation Report

The following list describes the Consolidation Report fields.

Consolidation Group

The Consolidation Group name specified on the METHOD statement CONSOLIDATE parameter or ACTION CONSOLIDATE statement GROUP parameter.

VTV

the volser of a VTV in the Consolidation Group.

An asterisk (*) denotes volumes that start a new Consolidation Group. LCM begins a new Consolidation Group for a new ACTION statement, an ACTION statement control break, and when LCM starts processing consolidations assigned by management methods.

Method

the management method assigned to the VTV. If the method has conditions, the method name is followed by a slash (/) and the number of the condition that applies.

Reason

the reason LCM assigned the management method to the VTV.

Note – If a volume is consolidated by an ACTION CONSOLIDATE statement, the Method column is ACTION and the Reason column is the ACTION statement name. In Figure 6-4, the first 3 volumes were selected for consolidation by the eighth ACTION statement in the LCM parameter file.

REPORT EJECT

The REPORT EJECT statement specifies options for an Eject Report. If an automatic Eject Report is printed, it uses the default options.

Syntax

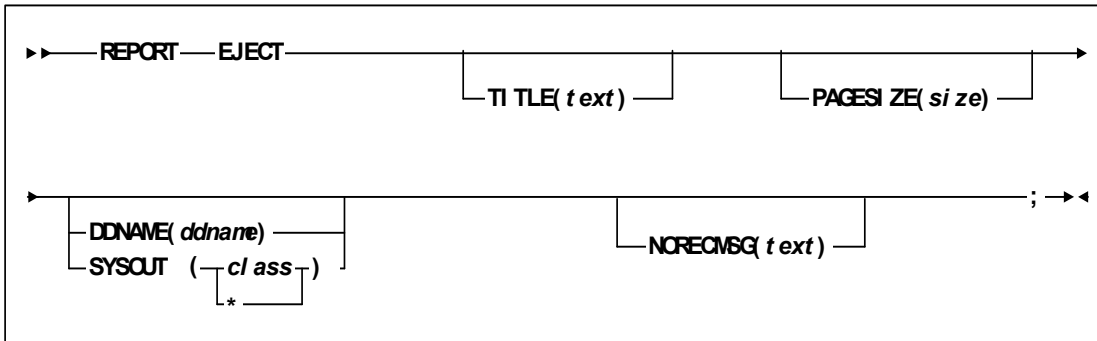

FIGURE 6-5 REPORT EJECT Statement Syntax

Parameters

TABLE 6-3 lists the valid abbreviations for the REPORT EJECT statement.

TABLE 6-3 REPORT EJECT Statement Abbreviations

Statement or Parameter	Abbreviation
REPORT	RPT
EJECT	EJ
DDNAME	DD,DDN

TITLE

specifies the title on each page of the report. The TITLE parameter of the OPTIONS statement defines a main title to be printed in the report headings. The title specified by the TITLE parameter of a REPORT statement is printed below this main title.

If you do not specify TITLE, the title is "Cell Count Report".

text

the title, which is a maximum of 70 characters.

PAGESIZE

specifies the maximum lines per page for printing the report.

size

the maximum lines per page. Valid values are 20 to 1000. You can specify a default pagesize for all reports on the ExLM main program JCL EXEC statement. Otherwise, the default is 58.

Note – You must specify the same lines per page for all reports written to the same ddname.

DDNAME

specifies the ddname where ExLM writes the report.

DDNAME and SYSOUT are mutually exclusive. If you specify neither, ExLM writes the report to DDNAME(SYSPRINT).

ddname

the ddname.

SYSOUT

specifies that ExLM writes the report to the specified SYSOUT class.

DDNAME and SYSOUT are mutually exclusive. If you specify neither, ExLM writes the report to DDNAME(SYSPRINT).

class

the SYSOUT class: A through Z or 0 through 9 or * for the default output class for the job.

NORECMMSG

specifies the text to print if no records are printed on the report. The specified text prints where the first record would appear.

text

specifies the text to print, which is a maximum of 70 characters. The default text is 'No records to print for this report.'

Note – If you explicitly code a statement for this report, it is **always** printed, even if there are no records to print.

Usage

Use the REPORT EJECT statement to specify options for an Eject Report. The Eject Report lists all volumes that LCM plans to eject through the specified LSM even if the volumes do not currently reside in that LSM.

Note – Note that:

- The LOCATION SLOTS | NOSLOTS parameter specifies whether LCM requests ejects in volser or slot order; for more information, see [“LOCATION” on page 91](#).

- The **OPTIONS** statement specifies global CAP and eject options; for more information, see [“OPTIONS” on page 114](#).
- The **LOCATION** statement specifies CAP and eject options for volumes with a specific TMS location code. For more information, see [“LOCATION” on page 91](#).
- You can use the **LCM DISPLAY**, **PAUSE**, **REDIRECT**, and **RESUME** commands to manage LCM activity for specific CAPs; for more information, see [“LCM Operator Commands” on page 379](#).

Eject Report

FIGURE 6-6 shows an example of an Eject Report.

2012-06-24 07:37:21		StorageTek Library Content Manager 7.2						PAGE 9	
		LCM Test Run							
LSM 00:00 Zero		Eject Report						EJECT	
Volume	Location	Slot	Method	Reason	Volume	Location	Slot	Method	Reason
H03736	Vault 1	123124	Action	Action/1	C03120	Vault 2	916	Offsite	Location
H04223	Vault 1	123125	Action	Action/1	*C0D0C0	Local		Standard	Default
*H05323	Vault 1	123126	Offsite	Location	C0D091	Local		Standard	Default
H05672	Vault 1	123127	Offsite	Location	*C01232	Local		QuickExit/1	Dataset
H05700	Vault 1	123128	Offsite	Location					
Note: "*" indicates a CAP break.									

FIGURE 6-6 Eject Report

The following list describes the Eject Report fields.

LSM

the LSM from which the volumes will be ejected.

Volume

the volser.

An asterisk (*) denotes a CAP break. LCM will cause a CAP break for a new ACTION statement, an ACTION statement control break, and when LCM starts processing ejects for content management. You must empty the CAP door before a new eject request can begin.

Method

the management method assigned to the VTV. If the method has conditions, the method name is followed by a slash (/) and the number of the condition that applies.

Reason

the reason LCM assigned the management method to the VTV.

Note – If a volume is ejected by an ACTION EJECT statement, the **Method** column is ACTION and the **Reason** column is the ACTION statement name. In Figure 6-6, the first two volumes were selected for ejection by the first ACTION statement in the LCM parameter file.

Location

the location name for the volume.

Slot

the slot number assigned to the volume by the TMS. This field is blank if slot numbers have not been assigned for this location or if the LOCATION NOSLOTS parameter is specified; for more information, see [“LOCATION” on page 91](#).

Method

the management method assigned to the volume. If the method has conditions, the method is followed by a slash (/) and the number of the COND that applies.

Reason

the reason the management method was assigned to the volume.

REPORT ENTER

The REPORT ENTER statement specifies options for an Enter Report. If an automatic Enter Report is printed, it uses the default options.

Syntax

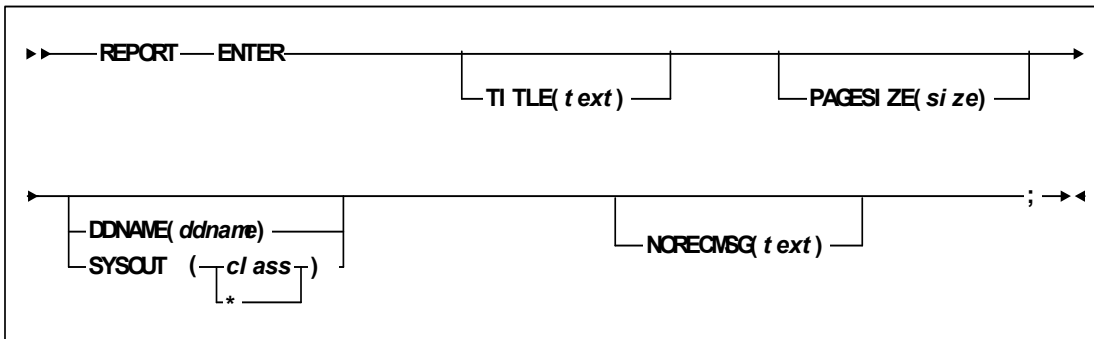

FIGURE 6-7 REPORT ENTER Statement Syntax

Parameters

TABLE 6-4 lists the valid abbreviations for the REPORT ENTER statement.

TABLE 6-4 REPORT ENTER Statement Abbreviations

Statement or Parameter	Abbreviation
REPORT	RPT
ENTER	EN
DDNAME	DD,DDN

TITLE

specifies the title on each page of the report. The TITLE parameter of the OPTIONS statement defines a main title to be printed in the report headings. The title specified by the TITLE parameter of a REPORT statement is printed below this main title.

If you do not specify TITLE, the title is "Cell Count Report".

text

the title, which is a maximum of 70 characters.

PAGESIZE

specifies the maximum lines per page for printing the report.

size

the maximum lines per page. Valid values are 20 to 1000. You can specify a default pagesize for all reports on the ExLM main program JCL EXEC statement. Otherwise, the default is 58.

Note – You must specify the same lines per page for all reports written to the same ddname.

DDNAME

specifies the ddname where ExLM writes the report.

DDNAME and SYSOUT are mutually exclusive. If you specify neither, ExLM writes the report to DDNAME(SYSPRINT).

ddname

the ddname.

SYSOUT

specifies that ExLM writes the report to the specified SYSOUT class.

DDNAME and SYSOUT are mutually exclusive. If you specify neither, ExLM writes the report to DDNAME(SYSPRINT).

class

the SYSOUT class: A through Z or 0 through 9 or * for the default output class for the job.

NORECMMSG

specifies the text to print if no records are printed on the report. The specified text prints where the first record would appear.

text

specifies the text to print, which is a maximum of 70 characters. The default text is 'No records to print for this report.'

Usage

Use the REPORT ENTER statement to specify options for an Enter Report. LCM creates an Enter Report for each LSM that needs volumes to be entered. If you specify the OPTIONS PICKSCR parameter, the Enter Report can include scratch volumes. The Enter Report lists nonscratch volumes if required by a PULLLIST statement. The report lists volumes in ascending order by location, slot and volume serial number.

If the LCM parameter file contains scratch criteria on the MANAGE PHYSICAL statement and also specifies OPTIONS PICKSCR, you should check the Scratch Counts Report or the Operator Report to determine whether more scratch volumes should be entered than are listed in the Enter Report; for more information, see [“REPORT SCRCNT” on page 311](#) and [“REPORT OPERATOR” on page 305](#).

Note – The PULLLIST statement specifies a list of volumes that an operator must enter for an upcoming production run..

Enter Report

FIGURE 6-8 shows an example of an Enter Report.

2012-06-24 07:37:21			StorageTek Library Content Manager 7.2			PAGE 8		
LCM Daily Run								
LSM 00:00 Zero			Enter Report			ENTER		
Volume	Location	Slot	Volume	Location	Slot	Volume	Location	Slot
A07782			A07832			A07882		
A07783			A07833	Vault 1	12811	A07883		
A07784			A07834	Vault 1	12812	A07884		
A07785			A07835	Vault 1	12813	A07885		
A07786			A07836	Vault 1	12814	A07886		

FIGURE 6-8 Enter Report

The following list describes the Enter Report fields.

LSM

the LSM into which the volumes should be entered.

Volume

the volser.

Location

the location name for the volume.

Slot

the slot number assigned to the volume by the TMS. This field is blank if slot numbers have not been assigned for this location or if the LOCATION NOSLOTS parameter is specified; for more information, see [“LOCATION” on page 91](#).

REPORT EXPORT

The REPORT EXPORT statement specifies options for an Export Report. If an automatic Export Report is printed, it uses the default options.

Syntax

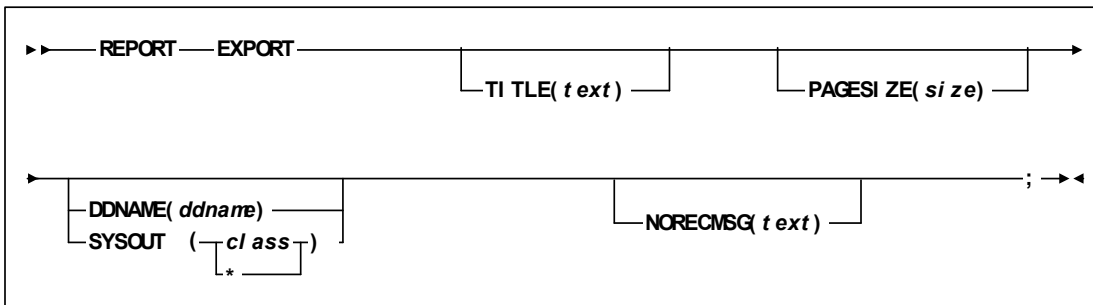

FIGURE 6-9 REPORT EXPORT Statement Syntax

Parameters

TABLE 6-5 lists the valid abbreviations for the REPORT ENTER statement.

TABLE 6-5 REPORT ENTER Statement Abbreviations

Statement or Parameter	Abbreviation
REPORT	RPT
EXPORT	EX
DDNAME	DD,DDN

TITLE

specifies the title on each page of the report. The TITLE parameter of the OPTIONS statement defines a main title to be printed in the report headings. The title specified by the TITLE parameter of a REPORT statement is printed below this main title.

If you do not specify TITLE, the title is "Cell Count Report".

text

the title, which is a maximum of 70 characters.

PAGESIZE

specifies the maximum lines per page for printing the report.

size

the maximum lines per page. Valid values are 20 to 1000. You can specify a default pagesize for all reports on the ExLM main program JCL EXEC statement. Otherwise, the default is 58.

Note – You must specify the same lines per page for all reports written to the same ddname.

DDNAME

specifies the ddname where ExLM writes the report.

DDNAME and SYSOUT are mutually exclusive. If you specify neither, ExLM writes the report to DDNAME(SYSPRINT).

ddname

the ddname.

SYSOUT

specifies that ExLM writes the report to the specified SYSOUT class.

DDNAME and SYSOUT are mutually exclusive. If you specify neither, ExLM writes the report to DDNAME(SYSPRINT).

class

the SYSOUT class: A through Z or 0 through 9 or * for the default output class for the job.

NORECMMSG

specifies the text to print if no records are printed on the report. The specified text prints where the first record would appear.

text

specifies the text to print, which is a maximum of 70 characters. The default text is 'No records to print for this report.'

Note – If you explicitly code a statement for this report, it is **always** printed, even if there are no records to print.

Usage

This report is based on the export operations LCM plans to perform. If LCM is stopped prematurely or is unable to perform some actions, the actual results may differ from those reported here.

This report is produced before any exports are actually performed. To print the report while LCM is still active, specify FREE=CLOSE on the associated DD statement.

The following example shows how to use two REPORT statements to produce two Export reports. One report is sent to a dynamically allocated SYSOUT file and the other is sent to DD OPER.

```

report export;           // Report for records.
report export           // Report for operator.
title('Export Report')
ddname(oper)
sysout(a) ;

```

To produce a post-action report that lists virtual tape volumes that were successfully exported, you can code a Report Volume statement similar to the following example:

```

report volume
when(action=Export and

                actionstatus=action successfully performed)

column(volser,method,methodreason,vtvmvcid1,vtvmvcid2,vtvtss);

```

LCM creates an Export report for each REPORT statement with type EXPORT coded. This report can also be produced automatically. To suppress these reports, specify SUPAUTORPT.

Export reports are written to the ddname specified on the associated REPORT statement. If no DDNAME is specified, LCM writes the report to a dynamically allocated SYSOUT file.

LCM will not create Export reports while in the SCAN execution modes.

Note – If LCM is stopped before the report completes, or LCM is unable to perform some actions, not all volumes listed will be exported. The LCM log, LCMLOG, will contain messages describing actions performed and, when appropriate, why actions were not completed.

Export Report

FIGURE 6-10 shows an example of an Export Report.

2012-09-15 15:06:28		StorageTek Library Content Manager 7.2	
LCMMJM1.SYSBACK.MANIFEST		Export Report	
		EXPORT	
Action statement: Action1.			
MVC	VTV	MVC	VTV
W00957	C07431	W01104	C07432
W00957	C08328		C08450
	C08933		
	C08923		
	C08309		
	C09265		
	C08914		
	C08802		

FIGURE 6-10 Export Report

The following list describes the Export Report fields.

MVC

the MVC used for exported VTVs.

The MVC volume serial applies to VTVs in the same column until a new MVC serial is printed.

VTV

the VTV exported to the current MVC.

REPORT MIGRATE

The REPORT MIGRATE statement specifies options for a Migration Report. If an automatic Migration Report is printed, it uses the default options.

Syntax

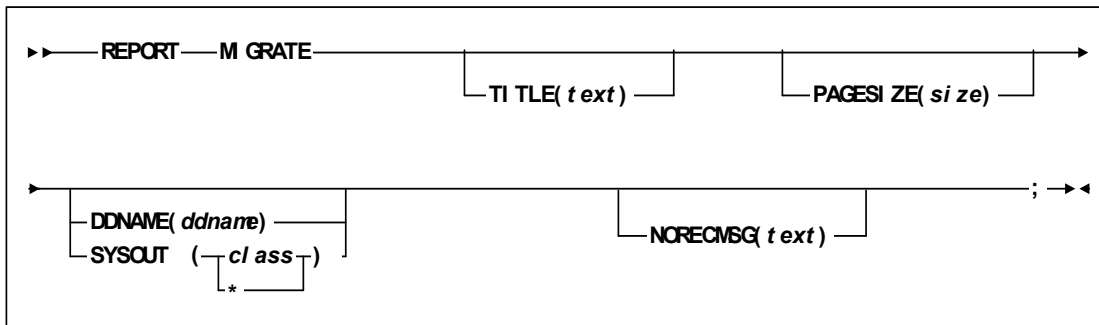

FIGURE 6-11 REPORT MIGRATE Statement Syntax

Parameters

TABLE 6-6 lists the valid abbreviations for the REPORT MIGRATE statement.

TABLE 6-6 REPORT MIGRATE Statement Abbreviations

Statement or Parameter	Abbreviation
REPORT	RPT
DDNAME	DD,DDN

TITLE

specifies the title on each page of the report. The TITLE parameter of the OPTIONS statement defines a main title to be printed in the report headings. The title specified by the TITLE parameter of a REPORT statement is printed below this main title.

If you do not specify TITLE, the title is "Cell Count Report".

text

the title, which is a maximum of 70 characters.

PAGESIZE

specifies the maximum lines per page for printing the report.

size

the maximum lines per page. Valid values are 20 to 1000. You can specify a default pagesize for all reports on the ExLM main program JCL EXEC statement. Otherwise, the default is 58.

Note – You must specify the same lines per page for all reports written to the same ddname.

DDNAME

specifies the ddname where ExLM writes the report.

DDNAME and SYSOUT are mutually exclusive. If you specify neither, ExLM writes the report to DDNAME(SYSPRINT).

ddname

the ddname.

SYSOUT

specifies that ExLM writes the report to the specified SYSOUT class.

DDNAME and SYSOUT are mutually exclusive. If you specify neither, ExLM writes the report to DDNAME(SYSPRINT).

class

the SYSOUT class: A through Z or 0 through 9 or * for the default output class for the job.

NORECMMSG

specifies the text to print if no records are printed on the report. The specified text prints where the first record would appear.

text

specifies the text to print, which is a maximum of 70 characters. The default text is 'No records to print for this report.'

Note – If you explicitly code a statement for this report, it is **always** printed, even if there are no records to print.

Usage

Use the REPORT MIGRATE statement to specify options for a Migration Report, which describes the migrations LCM will perform. If LCM stops prematurely or cannot perform all migrations, your mileage may vary from the Migration Report. This report is produced before any migrations occur, so if you want the report to print while LCM is still active, specify FREE=CLOSE on the associated DD statement.

To produce a post-action report that lists the VTVs that were successfully migrated, create a REPORT MIGRATE statement such as the following:

```
report migrate
```

```
  when(action='Migrate' and
```

```
    actionstatus='action successfully performed')
```

```
  column(volser,method,methodreason,vtvmvcid1,vtvmvcid2,vtvtss);
```

Migration Report

FIGURE 6-12 shows an example of an Migration Report.

2012-06-24 07:37:21		StorageTek Library Content Manager 7.2					PAGE 3	
LCM Daily Run								
Migration Report								MIGRATE
VTV	Method	Reason	VTV	Method	Reason	VTV	Method	Reason
C07782		Migrate1	C07832		Migrate2	C07882	MIG1	LOCATION
C07783		Migrate1	C07833		Migrate2	C07883	MIG1	LOCATION
C07784	MIG2	SetMethod	C07834	MIG3	LOCATION	C07884	MIG2	LOCATION
C07785	MIG2	SetMethod	C07835	MIG3	LOCATION	C07885	MIG2	LOCATION
C07786	MIG3	SetMethod	C07836	MIG3	LOCATION	C07886	MIG3	LOCATION

FIGURE 6-12 Migration Report

The following list describes the Migration Report fields.

VTV

the VTV volser.

Method

the management method assigned to the VTV. If the method had conditions, the method name is followed by a slash (/) and the number of the condition that applied.

Note – If a volume is migrated by an ACTION MIGRATE statement, the Method column is ACTION and the Reason column is the ACTION statement name.

Reason

the reason the management method was assigned to the volume.

REPORT NONSCRCNT

The REPORT NONSCRCNT statement specifies options for a Nonscratch Count Report.

Syntax

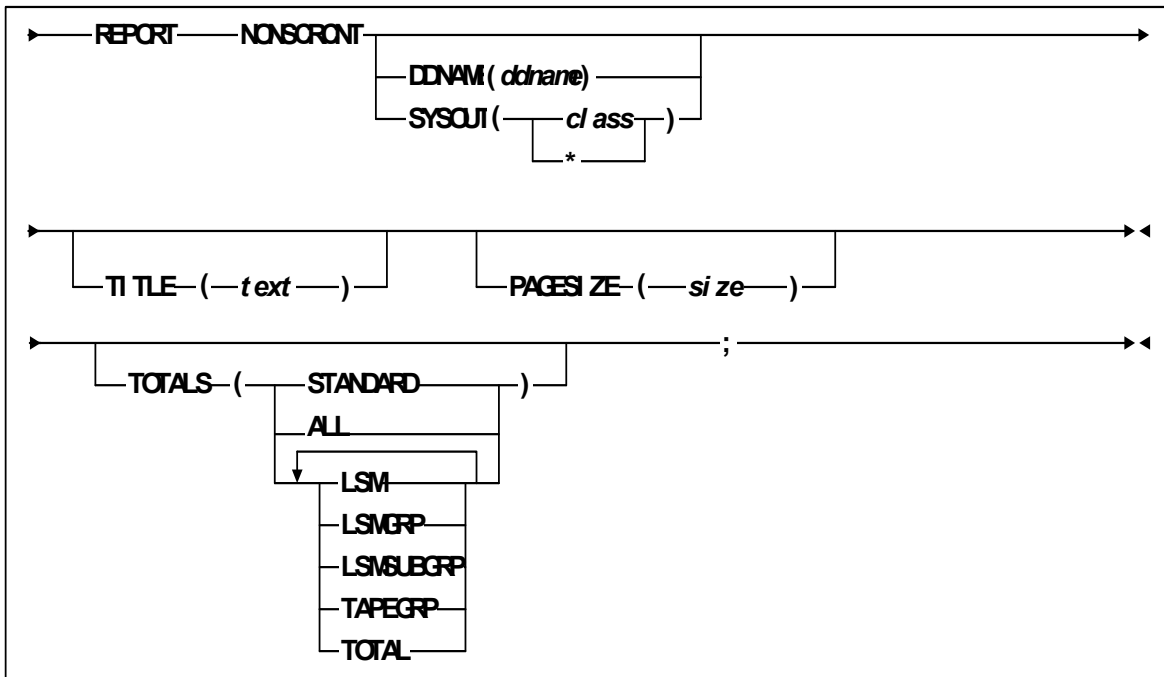

FIGURE 6-13 REPORT NONSCRCNT Statement Syntax

Parameters

TABLE 6-7 lists the valid abbreviations for the REPORT NONSCRCNT statement.

TABLE 6-7 REPORT NONSCRCNT Statement Abbreviations

Statement or Parameter	Abbreviation
REPORT	RPT
NONSCRCNT	NSC
DDNAME	DD,DDN

TABLE 6-7 REPORT NONSCRCNT Statement Abbreviations

Statement or Parameter	Abbreviation
STANDARD	STD
TAPEGRP	TG
TOTAL	TOT

TITLE

specifies the title on each page of the report. The TITLE parameter of the OPTIONS statement defines a main title to be printed in the report headings. The title specified by the TITLE parameter of a REPORT statement is printed below this main title.

If you do not specify TITLE, the title is "Cell Count Report".

text

the title, which is a maximum of 70 characters.

PAGESIZE

specifies the maximum lines per page for printing the report.

size

the maximum lines per page. Valid values are 20 to 1000. You can specify a default pagesize for all reports on the ExLM main program JCL EXEC statement. Otherwise, the default is 58.

Note – You must specify the same lines per page for all reports written to the same ddname.

DDNAME

specifies the ddname where ExLM writes the report.

DDNAME and SYSOUT are mutually exclusive. If you specify neither, ExLM writes the report to DDNAME(SYSPRINT).

ddname

the ddname.

SYSOUT

specifies that ExLM writes the report to the specified SYSOUT class.

DDNAME and SYSOUT are mutually exclusive. If you specify neither, ExLM writes the report to DDNAME(SYSPRINT).

class

the SYSOUT class: A through Z or 0 through 9 or * for the default output class for the job.

TOTALS

specifies the type of total lines for the *Nonscratch Counts Report*.

If you do not specify the TOTALS parameter, the default is STANDARD.

ALL
all types of totals.

LSM
totals for each LSM.

LSMGRP
totals for each LSM group.

LSMSUBGRP
totals for each LSM subgroup.

STANDARD
LCM selects totals.

TAPEGRP
totals for each tape group.

TOTAL
grand totals.

Usage

Use the REPORT NONSCRCNT statement to specify options for a Nonscratch Count Report.

Note – Note that:

- The OPTIONS statement specifies global options that affect nonscratch volumes; for more information, see [“OPTIONS” on page 114](#).
 - The PULLLIST statement specifies a list of volumes that an operator must enter for an upcoming production run.
-

Nonscratch Counts Reports

[FIGURE 6-14 on page 301](#) shows a Nonscratch Counts Report.

2012-04-17 14:28:08		StorageTek Library Content Manager 7.2										PAGE 4		
LCM Daily Run														
Nonscratch Counts Report														
NONSCRRCNT														
Physical														
Tape Group	--Non-Scratch--		--Reference--		---Eject---		---Move In---		---Move Out---		-Enter-			
	Init	Proj	Avg	Max	Always	Need	Always	Need	Always	Need	Always	Need		
Cleaning_Standard														
LSM 00:00	5	5	0	0	0	0	0	0	0	0	0	0	0	0
LSM 00:01	2	2	0	1	0	0	0	0	0	0	0	0	0	0
Tape Group	7	7	0	1	0	0	0	0	0	0	0	0	0	0

2012-04-17 14:28:08		StorageTek Library Content Manager 7.2										PAGE 5	
LCM Daily Run													
Nonscratch Counts Report													
NONSCRRCNT													
Multiple													
MVC Pool	--Free MVC--		--In-Use MVC--		---Reference---		--Actions---						
	Init	Proj	Init	Proj	Avg	Max	Drain	Export	Reclaim	Eject	Move In	Move Out	Enter
DEFAULTPOOL													
LSM 00:00	11	11	1	1	11	11	0	0	0	0	0	0	0
LSM 00:01	1	1	1	1	10	10	0	0	0	0	0	0	0
Total	12	12	2	2	21	21	0	0	0	0	0	0	0

2012-04-17 14:28:08		StorageTek Library Content Manager 7.2										PAGE 6		
LCM Daily Run														
Nonscratch Counts Report														
NONSCRRCNT														
Virtual														
Tape Group	--Non Scratch--		--Migrated--		--Resident--		Not In-Use		Reference		--Actions---			
	Yes	No	Yes	No	Yes	No	Avg	Max	Consolid	Export	Migrate	Recall		
A36	9000	9000	0	250	6000	8900	300	500	0	0	0	0	0	
B	5050	5049	1	500	3000	5000	200	400	0	0	0	0	0	
Total	14050	14049	1	750	9000	1390	500	900	0	0	0	0	0	

FIGURE 6-14 Nonscratch Counts Report

As [FIGURE 6-14](#) shows, this report is separated into three separate pages...one for native physical volumes, one for MVCs and one for VTVs. As with the scratch counts reports, raw counts and action related counts are separated on the pages.

The following list describes the Nonscratch Counts Report fields.

Tape Group

subpool name, followed by media type if this subpool is being managed by media type.

Nonscratch

the initial and projected number of nonscratch volumes.

Reference

the average and maximum days since last reference.

Eject

the projected number of volumes that LCM will eject. If you have specified on the `OPTIONS` or `LOCATION EJCAP` parameter, LCM can eject some or all of these volumes through the CAP of a different LSM. For more information, see [“OPTIONS” on page 114](#) and [“LOCATION” on page 91](#).

Always

the number of volumes being ejected due to an `ACTION EJECT` statement or because their assigned method indicates that they should always be ejected.

Need

the number of volumes being ejected because additional cells are needed in order to meet `NUMSCR` or `NUMFREE` criteria, to accommodate clearing frozen panels, or to provide for entering pull list volumes. Their assigned method indicates that they can be ejected as needed.

Move In

the projected number of volumes that will be moved in.

Always

the number of volumes being moved in due to an `ACTION MOVE` statement or because their assigned method indicates that they belong in the LSM group.

Need

the number of volumes being moved in because the LSM from which they are being moved is in need of additional room, or because `ClearFrozenPanels` was specified.

Move Out

the projected number of volumes that will be moved out.

Always

the number of volumes being moved out due to an `ACTION MOVE` statement or because their assigned method indicates that they belong in another LSM group.

Need

the number of volumes being moved out because additional cells are needed in order to meet `NUMSCR` or `NUMFREE` criteria, to clear frozen panels, or to provide for entering pull list volumes.

Enter

the projected number of volumes to be entered.

Free MVC, In Use MVC

the initial and projected number of MVCs that are free or in use.

Drain, Export, Reclaim

the projected number of MVCs that will be drained, exported, or reclaimed.

Consolid, Export, Migrate, Recall

the projected number of VTVs that will be consolidated, exported, migrated, or recalled.

Migrated

the number of VTVs migrated or not migrated.

Resident

the number of VTVs resident or not resident.

Not In-Use

the number of VTVs not in use.

REPORT OPERATOR

The REPORT OPERATOR statement specifies options for an Operator Report.

Syntax

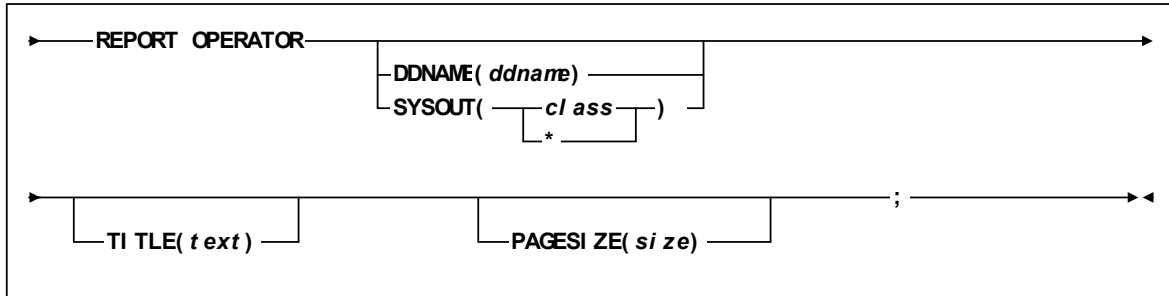

FIGURE 6-15 REPORT OPERATOR Statement Syntax

Parameters

TABLE 6-8 lists the valid abbreviations for the REPORT OPERATOR statement.

TABLE 6-8 REPORT OPERATOR Statement Abbreviations

Statement or Parameter	Abbreviation
REPORT	RPT
OPERATOR	OP
DDNAME	DD,DDN

TITLE

specifies the title on each page of the report. The TITLE parameter of the OPTIONS statement defines a main title to be printed in the report headings. The title specified by the TITLE parameter of a REPORT statement is printed below this main title.

If you do not specify TITLE, the title is "Cell Count Report".

text

the title, which is a maximum of 70 characters.

PAGESIZE

specifies the maximum lines per page for printing the report.

size

the maximum lines per page. Valid values are 20 to 1000. You can specify a default pagesize for all reports on the ExLM main program JCL EXEC statement. Otherwise, the default is 58.

Note – You must specify the same lines per page for all reports written to the same ddname.

DDNAME

specifies the ddname where ExLM writes the report.

DDNAME and SYSOUT are mutually exclusive. If you specify neither, ExLM writes the report to DDNAME(SYSPRINT).

ddname

the ddname.

SYSOUT

specifies that ExLM writes the report to the specified SYSOUT class.

DDNAME and SYSOUT are mutually exclusive. If you specify neither, ExLM writes the report to DDNAME(SYSPRINT).

class

the SYSOUT class: A through Z or 0 through 9 or * for the default output class for the job.

Usage

Use the REPORT OPERATOR statement to specify options for an Operator Report.

The Operator Report lists information and tells the operator what to do (enters and ejects, scratch synchronization runs, and so forth). The report is formatted like a checklist so the operator can check off completed items.

Note – If the LCM parameter file contains scratch criteria on the MANAGE PHYSICAL statement and also specifies OPTIONS PICKSCR, you should also check the Operator Report to determine whether more scratch volumes should be entered than are listed in the Enter Report; for more information, see [“REPORT ENTER” on page 288](#).

Operator Report

[FIGURE 6-16](#) shows an example of an Operator Report.

2012-03-17
13:37:07

StorageTek Library Content Manager 7.2

Page 2

Operator Report

OPERATOR

You can query the status of LCM by entering the operator command:
F V01,D

LCM will issue message LCM4016E and pause when it is ready to start processing planned actions. When you are ready for LCM to continue, use the LCM RESUME command.

When LCM4016E is displayed, issue operator command: F V01,R

LCM will eject cartridges during this run.

LCM will use the CAP doors of enhanced CAPs in parallel.

Each time a CAP door is unlocked, message SLS1251E will be issued to help you determine how to process the ejected cartridges.

LCM will move cartridges during this run.

LCM will consolidate virtual tape volumes during this run.

When LCM finishes, it will issue message LCM4019A. Reply U to this message and do the following:

Enter 19 scratch cartridges from tape group g into LSM 00:00.
Enter cartridges listed on enter report for LSM 00:01.
Enter 2 additional standard cleaning cartridges into LSM 00:01.
Enter cartridges listed on enter report for LSM 00:02.

FIGURE 6-16 Operator Report

REPORT RECALL

The REPORT RECALL statement specifies options for a Recall Report. If an automatic Export Report is printed, it uses the default options.

Syntax

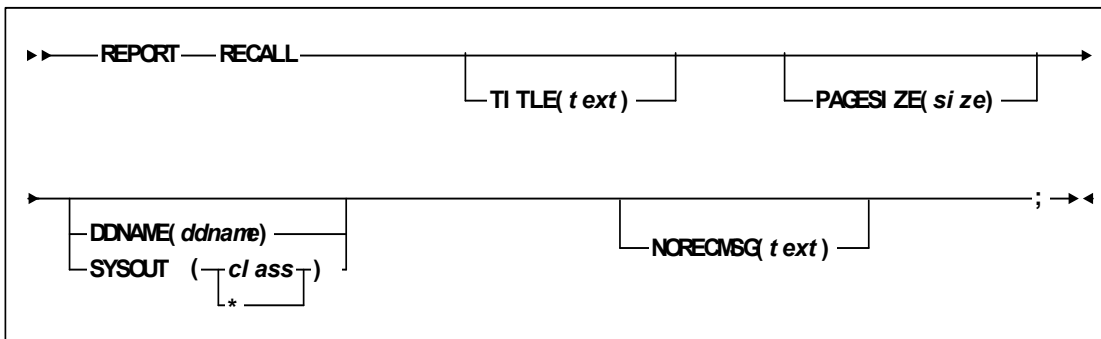

FIGURE 6-17 REPORT RECALL Statement Syntax

Parameters

TABLE 6-6 lists the valid abbreviations for the REPORT RECALL statement.

TABLE 6-9 REPORT RECALL Statement Abbreviations

Statement or Parameter	Abbreviation
REPORT	RPT
DDNAME	DD,DDN

TITLE

specifies the title on each page of the report. The TITLE parameter of the OPTIONS statement defines a main title to be printed in the report headings. The title specified by the TITLE parameter of a REPORT statement is printed below this main title.

If you do not specify TITLE, the title is "Cell Count Report".

text

the title, which is a maximum of 70 characters.

PAGESIZE

specifies the maximum lines per page for printing the report.

size

the maximum lines per page. Valid values are 20 to 1000. You can specify a default pagesize for all reports on the ExLM main program JCL EXEC statement. Otherwise, the default is 58.

Note – You must specify the same lines per page for all reports written to the same ddname.

DDNAME

specifies the ddname where ExLM writes the report.

DDNAME and SYSOUT are mutually exclusive. If you specify neither, ExLM writes the report to DDNAME(SYSPRINT).

ddname

the ddname.

SYSOUT

specifies that ExLM writes the report to the specified SYSOUT class.

DDNAME and SYSOUT are mutually exclusive. If you specify neither, ExLM writes the report to DDNAME(SYSPRINT).

class

the SYSOUT class: A through Z or 0 through 9 or * for the default output class for the job.

NORECMMSG

specifies the text to print if no records are printed on the report. The specified text prints where the first record would appear.

text

specifies the text to print, which is a maximum of 70 characters. The default text is 'No records to print for this report.'

Usage

Use the REPORT RECALL statement to specify options for a Recall Report, which describes the recalls LCM will perform. If LCM stops prematurely or cannot perform all recalls, your mileage may vary from the Recall Report. When LCM completes, the LCM log (LCMLOG) contains messages describing which actions were performed and, for those that could not be performed, messages describing why the actions did not complete.

To produce a post-action report that lists the VTVs that were successfully recalled, create a REPORT VOLUME statement such as the following:

```
report volume
```

```
  when(action='Recall' and
```

```
    actionstatus='action successfully performed')
```

```
  column(volser,method,methodreason,vtvmvcid1,vtvmvcid2,vtvtss);
```

Recall Report

Figure 6-18 shows an example of a Recall Report.

2012-06-24 07:37:21		StorageTek Library Content Manager 7.2					PAGE 3	
LCM Daily Run								
Recall Report								
RECALL								
VTV	Method	Reason	VTV	Method	Reason	VTV	Method	Reason
C07782		Recall1	C07832		Recall2	C07882	REC1	LOCATION
C07783		Recall1	C07833		Recall2	C07883	REC1	LOCATION
C07784	REC2	SetMethod	C07834	REC3	LOCATION	C07884	REC2	LOCATION
C07785	REC2	SetMethod	C07835	REC3	LOCATION	C07885	REC2	LOCATION
C07786	REC3	SetMethod	C07836	REC3	LOCATION	C07886	REC3	LOCATION

FIGURE 6-18 Recall Report

The following list describes the Recall Report fields.

VTV

the VTV volser.

Method

the management method assigned to the VTV. If the method had conditions, the method name is followed by a slash (/) and the number of the condition that applied.

Note – If a volume is recalled by an ACTION RECALL statement, the Method column is RECALL and the Reason column is the ACTION statement name. If a volume is recalled by a PULLLIST statement, the Method column is PULLLIST and the Reason column is the PULLLIST statement name.

Reason

the reason the management method was assigned to the volume.

REPORT SCRCNT

The REPORT SCRCNT statement specifies options for a Scratch Count Report.

Syntax

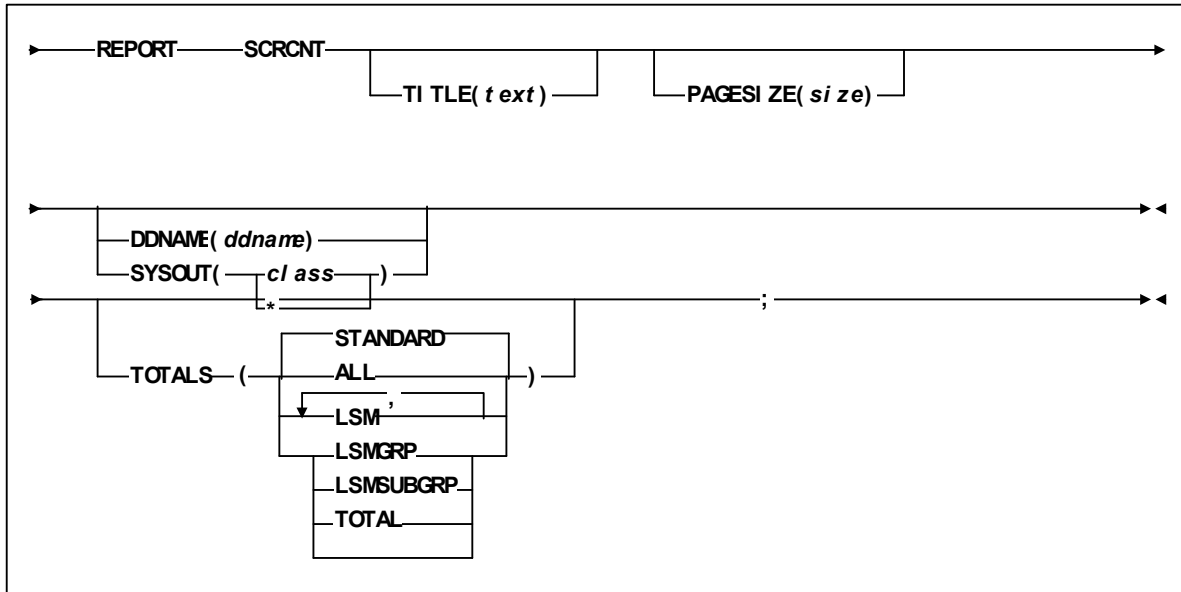

FIGURE 6-19 REPORT SCRCNT Statement Syntax

Parameters

“[REPORT SCRCNT Statement Abbreviations](#)” on page 311 lists the valid abbreviations for the REPORT SCRCNT statement.

TABLE 6-10 REPORT SCRCNT Statement Abbreviations

Statement or Parameter	Abbreviation
REPORT	RPT
SCRCNT	SC
DDNAME	DD,DDN
STANDARD	STD
TAPEGRP	TG
TOTAL	TOT

TITLE

specifies the title on each page of the report. The TITLE parameter of the OPTIONS statement defines a main title to be printed in the report headings. The title specified by the TITLE parameter of a REPORT statement is printed below this main title.

If you do not specify TITLE, the title is "Cell Count Report".

text

the title, which is a maximum of 70 characters.

PAGESIZE

specifies the maximum lines per page for printing the report.

size

the maximum lines per page. Valid values are 20 to 1000. You can specify a default pagesize for all reports on the ExLM main program JCL EXEC statement. Otherwise, the default is 58.

Note – You must specify the same lines per page for all reports written to the same ddname.

DDNAME

specifies the ddname where ExLM writes the report.

DDNAME and SYSOUT are mutually exclusive. If you specify neither, ExLM writes the report to DDNAME(SYSPRINT).

ddname

the ddname.

SYSOUT

specifies that ExLM writes the report to the specified SYSOUT class.

DDNAME and SYSOUT are mutually exclusive. If you specify neither, ExLM writes the report to DDNAME(SYSPRINT).

class

the SYSOUT class: A through Z or 0 through 9 or * for the default output class for the job.

TOTALS

specifies the type of total lines for the *scratch Counts Report*.

If you do not specify the TOTALS parameter, the default is STANDARD.

ALL

all types of totals.

LSM

totals for each LSM.

LSMGRP

totals for each LSM group.

LSMSUBGRP

totals for each LSM subgroup.
STANDARD
LCM selects totals.
TAPEGRP
totals for each tape group.
TOTAL
grand totals.

Usage

Use the REPORT SCRCNT statement to specify options for a Scratch Count Report.

Note – Note that:

- The OPTIONS statement specifies global options that affect scratch volumes; for more information, see [“OPTIONS” on page 114](#).
 - The Scratch Count report also includes VTVs if they exist and if a VSM-specific option or field is specified.
 - This report uses a “+” suffix to denote scratch counts, subtotals, and totals for existing VTV scratch volumes. Note that these counts are for only existing scratch VTVs when you ran the report, not for nonexistent scratch VTVs (which VSM can create as needed to satisfy scratch request), so actual scratch counts are generally higher.
-

Scratch Counts Report

FIGURE 6-20 shows an example Scratch Counts Report.

2012-04-17 14:28:08		StorageTek Library Content Manager 7.2								PAGE 3		
Daily Vaulting Run												
Scratch Counts Report										SCRCNT		
Tape Group	--Scratch--		--Bad Scratch--		--Synchronize--		--Eject--	-Move In-	-Move Out-	----Enter----		
	Init	Proj	Init	Proj	Change	Wrong				Report	Add'l	
General												
LSM 00:00	0	0	0	0	0	0	0	0	0	0	0	
LSM 00:01	0	0	0	0	0	0	0	0	0	0	0	
LSM VSM	9972+	9972+	0	0	0	0	0	0	0	0	0	
Tape Group	9972+	9972+	0	0	0	0	0	0	0	0	0	
HSM												
LSM 00:00	0	0	0	0	0	0	0	0	0	0	0	
LSM 00:01	0	0	0	0	0	0	0	0	0	0	0	
Tape Group	0	0	0	0	0	0	0	0	0	0	0	
Production												
LSM 00:00	1157	1500	0	0	0	0	0	343	0	0	0	
LSM 00:01	1154	811	0	0	0	0	0	14	357	0	0	
LSM VSM	9609+	9609+	0	0	0	0	0	0	0	0	0	
Tape Group	11920+	11920+	0	0	0	0	0	357	357	0	0	
Total	21892+	21892+	0	0	1	0	0	357	357	0	0	
Virtual												
Tape Group	--Scratch-	--Migrated--		--Resident--		Not In-Use	Synchronize			--Actions--		
	-	Yes	No	Yes	No		Change	Wrong	Consolid	Export	Migrate	Recall
A36	1000	9000	0	250	6000	8900	40	0	0	0	0	0
B	500	600	0	150	3000	1000	25	0	0	0	0	0
Total	1500	1500	0	400	9000	9900	65	0	0	0	0	0

FIGURE 6-20 Scratch Counts Report

As shown in FIGURE 6-20, this report now separates scratch counts by physical and virtual volumes on separate pages. Virtual counts page only appears when appropriate. Additionally, the report is separated by raw counts and counts based upon actions.

The following list describes the Scratch counts Report fields. For more information about VSM information on this report, see "Usage" on page 313.

Tape Group

subpool name, followed by media type if this subpool is being managed by media type.

Scratch

the initial and projected number of scratch volumes.

Bad Scratch

the initial and projected number of bad scratch volumes.

Synchronize

counts associated with scratch synchronization.

Change

volumes whose scratch status was changed.

Wrong

volumes with incorrect scratch status:

- If `OPTIONS NOSYNC` is specified, the count of volumes whose HSC volume scratch status indicators do not match TMS status.
- If `OPTIONS SYNC` is specified, the count of volumes LCM was unable to SYNC or HSCUNSCR because of errors as described in a message written to the log file.

Eject

the projected number of volumes that LCM will eject. If you have specified the `OPTIONS EJCAP` parameter, LCM can eject some or all of these volumes through the CAP of a different LSM. For more information, see [“OPTIONS” on page 114](#).

Move In

the number of scratch and bad scratch volumes being moved in.

Move Out

the number of scratch and bad scratch volumes being moved out.

Enter

the number of scratch volumes that need to be entered.

Report

the number of scratch volumes on the Enter Report.

Addn'l

the scratch volumes required in addition to the number listed on the Enter Report.

Consolid, Export, Migrate, Recall

the projected number of VTVs that will be consolidated, exported, migrated, or recalled.

Migrated

the number of VTVs migrated or not migrated.

Resident

the number of VTVs resident or not resident.

Not In-Use

the number of VTVs not in use.

REPORT SUMMARY

The REPORT SUMMARY statement specifies options for a Summary Report.

Syntax

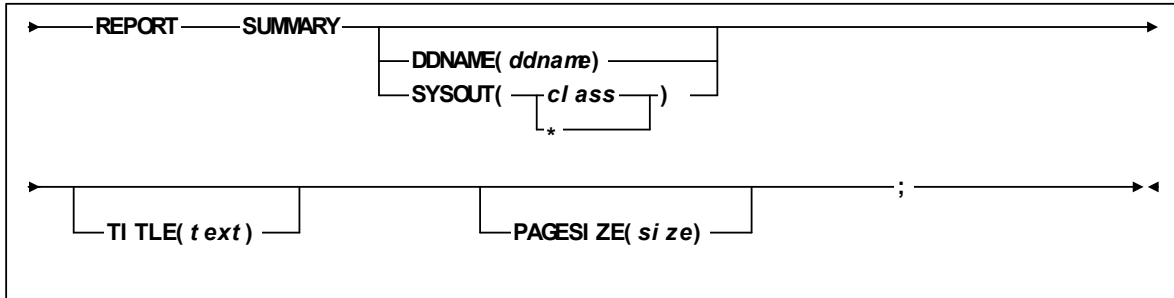

FIGURE 6-21 REPORT SUMMARY Statement Syntax

Parameters

TABLE 6-11 lists the valid abbreviations for the REPORT SUMMARY statement. TITLE

TABLE 6-11 REPORT SUMMARY Statement Abbreviations

Statement or Parameter	Abbreviation
REPORT	RPT
SUMMARY	SUM
DDNAME	DD,DDN

specifies the title on each page of the report. The TITLE parameter of the OPTIONS statement defines a main title to be printed in the report headings. The title specified by the TITLE parameter of a REPORT statement is printed below this main title.

If you do not specify TITLE, the title is “Cell Count Report”.

text

the title, which is a maximum of 70 characters.

PAGESIZE

specifies the maximum lines per page for printing the report.

size

the maximum lines per page. Valid values are 20 to 1000. You can specify a default pagesize for all reports on the ExLM main program JCL EXEC statement. Otherwise, the default is 58.

Note – You must specify the same lines per page for all reports written to the same ddname.

DDNAME

specifies the ddname where ExLM writes the report.

DDNAME and SYSOUT are mutually exclusive. If you specify neither, ExLM writes the report to DDNAME(SYSPRINT).

ddname

the ddname.

SYSOUT

specifies that ExLM writes the report to the specified SYSOUT class.

DDNAME and SYSOUT are mutually exclusive. If you specify neither, ExLM writes the report to DDNAME(SYSPRINT).

class

the SYSOUT class: A through Z or 0 through 9 or * for the default output class for the job.

Usage

Use the REPORT SUMMARY statement to specify options for a Summary Report.

The Scratch Count report also includes VTVs if they exist and if a VSM-specific option or field is specified. This report uses a “+” suffix to denote scratch counts, subtotals, and totals for existing VTV scratch volumes and for defined but not yet existing scratch VTVs (which VSM can create as needed to satisfy scratch request).

Summary Report

[FIGURE 6-22](#) shows an example Summary Report.

2012-04-17 14:28:08		StorageTek Library Content Manager 7.2										PAGE 1		
LCM Daily Run														
Daily Run Summary Report												SUMMARY		
	Free Cells	--MVC--				---Synchronize---				--Actions---				
		Free	In-Use	Scratch	Non-Scratch	Change	Wrong	Drain	Export	Reclaim	Eject	Move In	Move Out	Enter
LSM 01:03	1015	105	100	0	5	0	0	0	0	0	0	0	0	0
LSM 02:03	1025	90	70	0	5	0	0	0	0	0	0	0	0	0
All LSMs	2040	195	170	0	10	0	0	0	0	0	0	0	0	0
						---Synchronize---				--Actions---				
				Scratch	Non-Scratch	Change	Wrong	Consolid	Export	Migrate	Recall			
Virtual				23995	105400	1150	4	0	0	0	0			

FIGURE 6-22 Summary Report

As [FIGURE 6-22](#) shows, This report is reformatted in a similar manner as the scratch and nonscratch reports with raw counts and action related counts separated. Virtual volumes are separated from physical volumes as actions are different.

The following list describes the Summary Report fields. For more information about VSM information on this report, see “Usage” on page 317.

LSM

hexadecimal LSM ID. For VTVs, the LSM is reported as “VSM”.

Name

user-assigned LSM name from the `MANAGE PHYSICAL` statement.

Free Cells

total number of free cells projected for the LSM after all scheduled cartridge moves, ejects, and enters have been performed.

Scratch

total number of scratch volumes projected for the LSM after all scheduled cartridge moves, ejects, and enters have been performed.

Non-Scratch

total number of nonscratch volumes projected for the LSM after all scheduled cartridge moves, ejects, and enters have been performed.

Ignored

total number of volumes ignored because the `SUBPOOL IGNORE` parameter was specified.

Eject

the projected number of volumes that LCM will eject. If you have specified the `OPTIONS EJCAP` parameter, LCM can eject some or all of these volumes through the CAP of a different LSM. For more information, see [“OPTIONS” on page 114](#).

Move In

the projected number of volumes that will be moved into the LSM.

Move Out

the projected number of volumes moved out of the LSM.

Enter

volumes to be entered into the LSM.

Status Change

volumes whose scratch status was changed in the HSC CDS by the LCM run. This count does not include status changes to be made with any movement into or out of an HSCUNSCR LSM group.

Status Wrong

volumes with incorrect scratch status:

- If **OPTIONS NOSYNC** is specified, the count of volumes whose HSC volume scratch status indicators do not match TMS status.
- If **OPTIONS SYNC** is specified, the count of volumes LCM was unable to **SYNC** or **HSCUNSCR** because of errors as described in a message written to the log file.

Consolid, Export, Migrate, Recall

the projected number of VTVs that will be consolidated, exported, migrated, or recalled.

Optional Reports

LCM Optional Reports, unlike Standard Reports, are not automatically produced; you must specifically request them. Optional Reports have a fixed output, and default and specifiable selection criteria for report contents.

A Data Set Report requires a REPORT DATASET statement to define the report contents and a REPORT parameter on the DATASET statement. For more information, see [“REPORT DATASET” on page 321](#) and [“DATASET” on page 86](#).

The Physical, Multiple, and Virtual reports are generated only when the following statements appear in an LCM Parameter File:

- [“REPORT MULTIPLE” on page 325](#)
- [“REPORT PHYSICAL” on page 331](#)
- [“REPORT VAULT” on page 339](#)
- [“REPORT VIRTUAL” on page 347](#)

REPORT DATASET

The REPORT DATASET statement specifies options for a Data Set Report. If an automatic Dataset Report is printed, it uses the default options.

Syntax

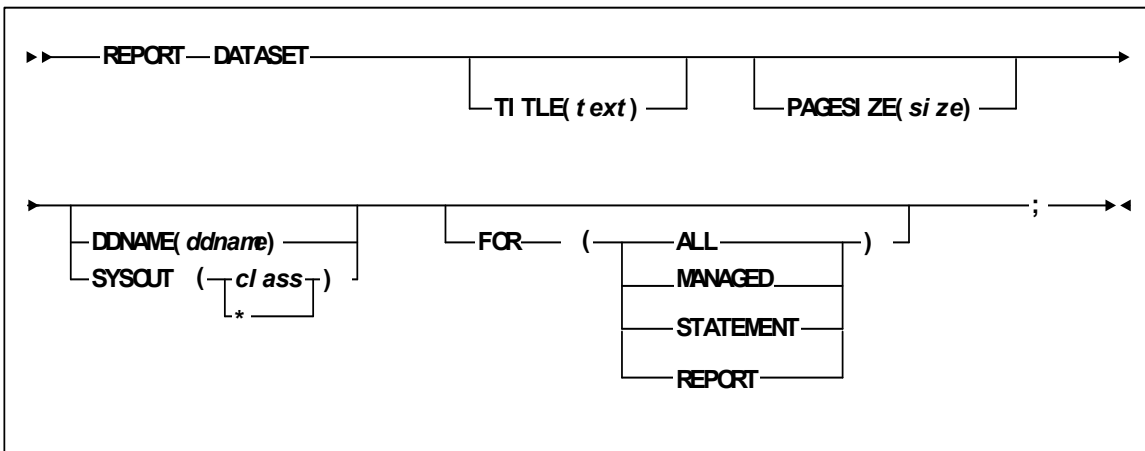

FIGURE 6-23 REPORT DATASET Statement Syntax

Parameters

TABLE 6-12 lists the valid abbreviations for the REPORT DATASET statement.

TABLE 6-12 REPORT DATASET Statement Abbreviations

Statement or Parameter	Abbreviation
REPORT	RPT
DATASET	DS
DDNAME	DD,DDN

TITLE

specifies the title on each page of the report. The TITLE parameter of the OPTIONS statement defines a main title to be printed in the report headings. The title specified by the TITLE parameter of a REPORT statement is printed below this main title.

If you do not specify TITLE, the title is "Cell Count Report".

text

the title, which is a maximum of 70 characters.

PAGESIZE

specifies the maximum lines per page for printing the report.

size

the maximum lines per page. Valid values are 20 to 1000. You can specify a default pagesize for all reports on the ExLM main program JCL EXEC statement. Otherwise, the default is 58.

Note – You must specify the same lines per page for all reports written to the same ddname.

DDNAME

specifies the ddname where ExLM writes the report.

DDNAME and SYSOUT are mutually exclusive. If you specify neither, ExLM writes the report to DDNAME(SYSPRINT).

ddname

the ddname.

SYSOUT

specifies that ExLM writes the report to the specified SYSOUT class.

DDNAME and SYSOUT are mutually exclusive. If you specify neither, ExLM writes the report to DDNAME(SYSPRINT).

class

the SYSOUT class: A through Z or 0 through 9 or * for the default output class for the job.

FOR

specifies the data sets included on the Data Set Report. If you do not specify the FOR parameter, the default is REPORT.

ALL

all data sets processed by LCM except data sets that belong to a subpool for which:

- IGNORE has been specified.
- the TMS is different than that specified on the TMSNAME parameter.

For more information, see [“SUBPOOL” on page 140](#).

MANAGED

only volumes covered by a MANAGE statement.

STATEMENT

only volumes of data sets covered by a DATASET statement.

REPORT

only volumes of data sets covered by a DATASET statement with the REPORT option.

Usage

Use the REPORT DATASET statement to specify options for a Data Set Report, which displays data set and associated volume information.

Data Set Report

Figure 6-24 shows an example of a Data Set Report.

2012-03-02 13:37:21	StorageTek Library Content Manager 7.2								PAGE 7
	LCM Daily Run								
TMS Main	Covered Data Sets								DATASET
Data Set Name	Seq	Serial	Location	LSM	Method	Reason	Cr Date	Rf Date	Covered by
OPR.SYSLOG.DAILY.G0598VOO	1	C00855	Local	00:01	Syslog	Dataset	2000-02-23	2000-02-23	OPR.SYSLOG.**
OPR.SYSLOG.DAILY.G0597VOO	1	C00477	Local	00:01	Syslog	Dataset	2000-02-22	2000-02-23	OPR.SYSLOG.**
OPR.SYSLOG.DAILY.G0596VOO	1	C00632	Local	00:00	Syslog	Dataset	1998-03-22	1998-03-22	OPR.SYSLOG.**
SYSBACK.ADOC.SEM.G0001VO O	1	C01686	Local	00:01	Sem/2	Dataset	1998-03-22	1998-03-22	SYSBACK.*.S*.
SYSBACK.ADOC.SEM.G0001VO O	1	C01683	Local	00:01	Sem/2	Dataset	1998-03-22	1998-03-22	SYSBACK.*.S*.

FIGURE 6-24 Data Set Report

The following list describes the Data Set Report fields.

Data Set Name

the name of the first data set on the volume. The data set name is blank for subsequent volumes of a multi-volume data set.

Seq

the sequence number of a volume allocated to a multi-volume data set. Seq is 1 for a single volume data set.

Serial

the volser of the volume associated with the data set.

Location

the location name for the data set's associated volume.

LSM

the hexadecimal LSM ID where the volume resides. This field is a dash (-) if the volume is not in an LSM.

Method

the management method assigned to the volume.

If the method has conditions, the method is followed by a slash (/) and the number of the COND that applies. If the management method assigns EJECT(ASNEEDED) to the volume and if CYCLESOON, MINENTER, or MINREF also applies to the volume, a dash (-) precedes the name of the method to show that EJECT(NO) overrode EJECT(ASNEEDED).

Reason

the reason the management method was assigned to the volume.

Cr Date

the data set's creation date as reported by the TMS.

Rf Date

the data set's last referenced date as reported by the TMS.

Covered by

the most specific matching identifier for the data set name on a DATASET statement in the parameter file used for this run.

REPORT MULTIPLE

The REPORT MULTIPLE statement specifies options for an MVC Report.

Syntax

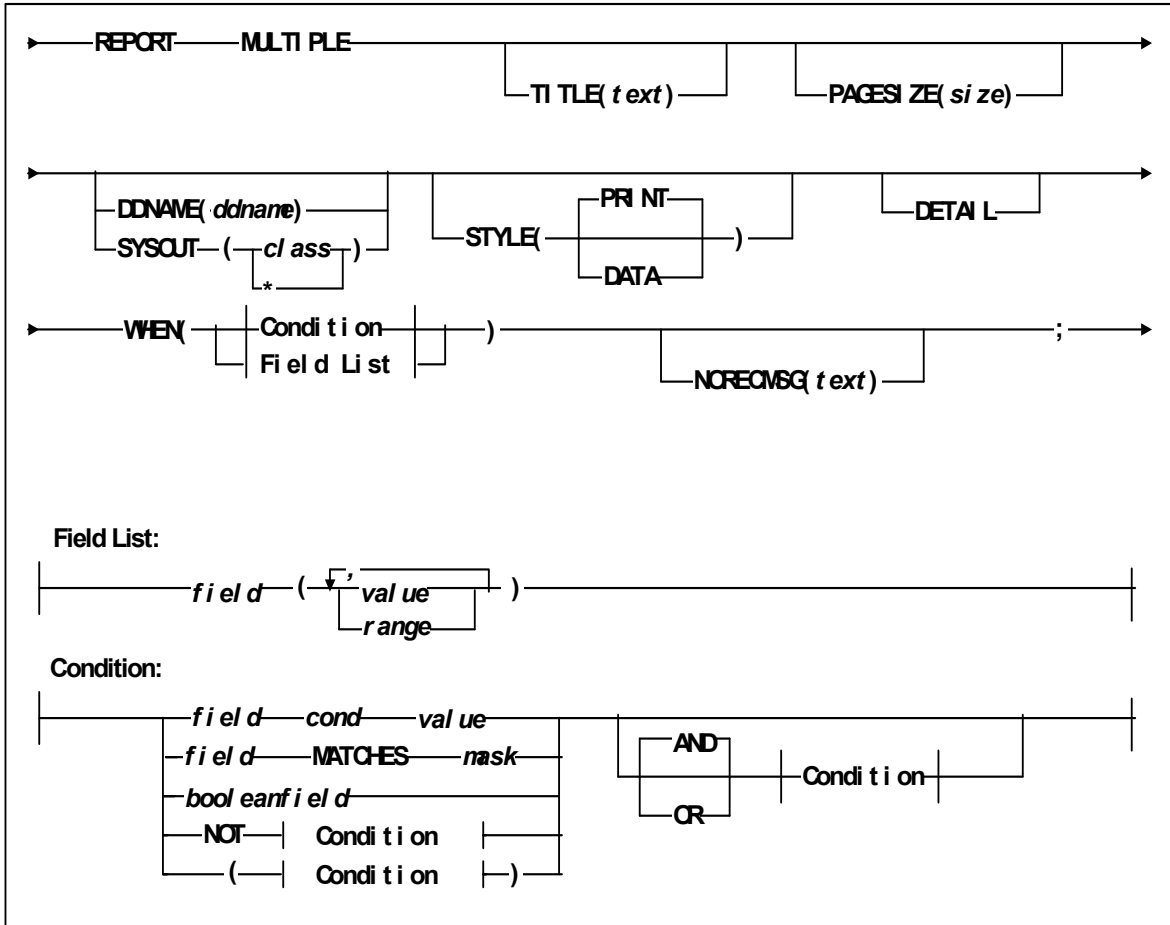

FIGURE 6-25 REPORT MULTIPLE Statement Syntax

Parameters

TITLE

specifies the title on each page of the report. The TITLE parameter of the OPTIONS statement defines a main title to be printed in the report headings. The title specified by the TITLE parameter of a REPORT statement is printed below this main title.

If you do not specify TITLE, the title is “Cell Count Report”.

text

the title, which is a maximum of 70 characters.

PAGESIZE

specifies the maximum lines per page for printing the report.

size

the maximum lines per page. Valid values are 20 to 1000. You can specify a default pagesize for all reports on the ExLM main program JCL EXEC statement. Otherwise, the default is 58.

Note – You must specify the same lines per page for all reports written to the same ddname.

DDNAME

specifies the ddname where ExLM writes the report.

DDNAME and SYSOUT are mutually exclusive. If you specify neither, ExLM writes the report to DDNAME(SYSPRINT).

ddname

the ddname.

SYSOUT

specifies that ExLM writes the report to the specified SYSOUT class.

DDNAME and SYSOUT are mutually exclusive. If you specify neither, ExLM writes the report to DDNAME(SYSPRINT).

class

the SYSOUT class: A through Z or 0 through 9 or * for the default output class for the job.

STYLE (PRINT | DATA | DATA CSV | DATA CSV TRIM)

specifies the report style.

PRINT

format the report for printing (include report titles and column headings).

Printed reports have the same DCB requirements as the other ExLM reports. See [“Using LCM to Manage Nearline Resources” on page 28](#) for more information about DCB attributes.

DATA

format the report for post processing without report titles and column headings. You can direct DATA reports to any data set with a RECFM of F, FB, V, or VB that has an LRECL large enough to accommodate an output line.

If you specify STYLE(DATA), you cannot specify the:

- PAGESIZE parameter,
- PAGE subparameter of the CONTROL parameter, and
- HEADING subparameter of the COLUMN parameter.

CSV

Presents the data in a Comma Separated Variable (CSV) format for entry into a spreadsheet.

TRIM

Deletes the trailing blanks of a metadata field.

DETAIL

produce a detailed report, including all the VTVs on each MVC. If you do not specify this option, the default is to produce a summary report of MVCs only.

WHEN(*condition*)

specifies one of the following for volume selection:

Field List

specifies the fields to use for volume selection. For a volume to be selected, the value for each *field* must match at least one of the provided *values* or *ranges*.

The valid *values* depend on the type of *field* as described in [TABLE 6-13](#).

TABLE 6-13 Valid Types of Fields

Type	Values and Examples
Boolean	Specify TRUE or FALSE. FALSE is less than TRUE in comparisons.
Character or mixed character and integer string; also applies to ranges	Specify the string in single quotes. For example: WHEN(SERIAL('A00001')) WHEN(SERIAL('A00001'-'A99999'))

TABLE 6-13 Valid Types of Fields

Type	Values and Examples
Date	Specify a date constant or MISSING. Date constants are of the form 'date'D or 'date'd where date can be specified in any date format defined in the "SET METHOD Statement WHEN Fields" section of <i>LCM Quick Reference</i> except TEXTDAYDATE. You must follow the format exactly. For example: '05Sep93'd is valid but '5Sep93'd is not.
Integer	Specify a number or MISSING. For example: 123
Time	Specify a time constant or MISSING. Time constants are of the form 'time'T where time can be specified in any time format defined in the "SET METHOD Statement WHEN Fields" section of <i>LCM Quick Reference</i> . You must follow the format exactly. For example: '12:30't is valid but '12;30't is not.

MISSING can also be specified as a period ("."). MISSING is less than all other values.

TABLE 6-14 Valid Formats for Date Fields

Type	Size	Example
yyddd	5	97248
ccyyddd	7	1997248
yy.ddd	6	97.248
ccyy.ddd	8	1997.248
mm/dd/yy	8	09/05/97
mm/dd/ccyy	10	09/05/1997
yy-mm-dd	8	93-09-05
yyyy-mm-dd	10	2000-09-05 This is the default.
dd_mmm_yy	9	09 Sep 98
dd_mmm_ccyy	11	09 Sep 2000
ddmmmyy	7	09Sep98
ddmmmcyy	9	09Sep1997
textdate	18	September 9, 2000
textdaydate	29	Wednesday, September 10, 2000

TABLE 6-15 Valid Formats for Time Fields

Type	Size	Example
hh:mm	5	22:21 This is the default.
hh:mm:ss	8	22:21:32
hh:mm:ss_pm	11	10:21:32 PM

Condition

specifies a condition for volume selection.

field cond value

specifies a field, a condition, and a value to compare with one of the following conditions:

EQ

equal to.

NE

not equal to.

GE

greater than or equal to.

GT

greater than.

LE

less than or equal to.

LT

less than.

For example, `VOLSER GE A00243` selects volsers greater than or equal to A00243.

field MATCHES *mask*

specifies a field and a mask for selection. The valid masks depend on the field selected:

■ **DATASETNAME, BASENAME:** Specify a string in single quotes.

Wildcards can be used as follows:

`"**"` matches one or more data set qualifiers.

`"*"` matches one or more characters within a qualifier.

`"%"` matches one character within a qualifier.

■ **Other character fields:** Specify a string in single quotes. Wildcards can be used as follows:

`"*"` matches one or more characters.

`"%"` matches one character.

For example, `DataSetName MATCHES DR*` selects all data sets with HLQs beginning with DR.

booleanfield

specifies a Boolean field to be tested for TRUE. Specify NOT before the field if you want to test for FALSE.

For example, `CLN` selects volumes that are cleaning cartridges.

NOT

reverses the condition that immediately follows the NOT keyword.

For example, `NOT CLN` selects volumes that are **not** cleaning cartridges.

AND

make the selection if both conditions are true.

For example, `NOT CLN AND SERIAL(A00500-A00750)` selects volumes A00500 through A00750 that are **not** cleaning cartridges.

OR

make the selection if either condition is true. For example, NOT CLN OR SERIAL(A00500-A00750) selects volumes A00500 through A00750 **or** volumes that are not cleaning cartridges.

Note – For complete information on the fields available, their types, values, and use, see *LCM Quick Reference*.

NORECMMSG

specifies the text to print if no records are printed on the report. The specified text prints where the first record would appear.

text

specifies the text to print, which is a maximum of 70 characters. The default text is 'No records to print for this report.'

Usage

The REPORT PHYSICAL, REPORT MULTIPLE, and REPORT VIRTUAL statements generate an expanded listing in the joblog showing the statements created for the appropriate Custom Report. You can copy the listing in the joblog to your LCMLIB, modify as desired, and submit. For more information, see [“REPORT Statement Templates” on page 15](#).

REPORT PHYSICAL

The REPORT PHYSICAL statement specifies options for a Nearline volume report.

Syntax

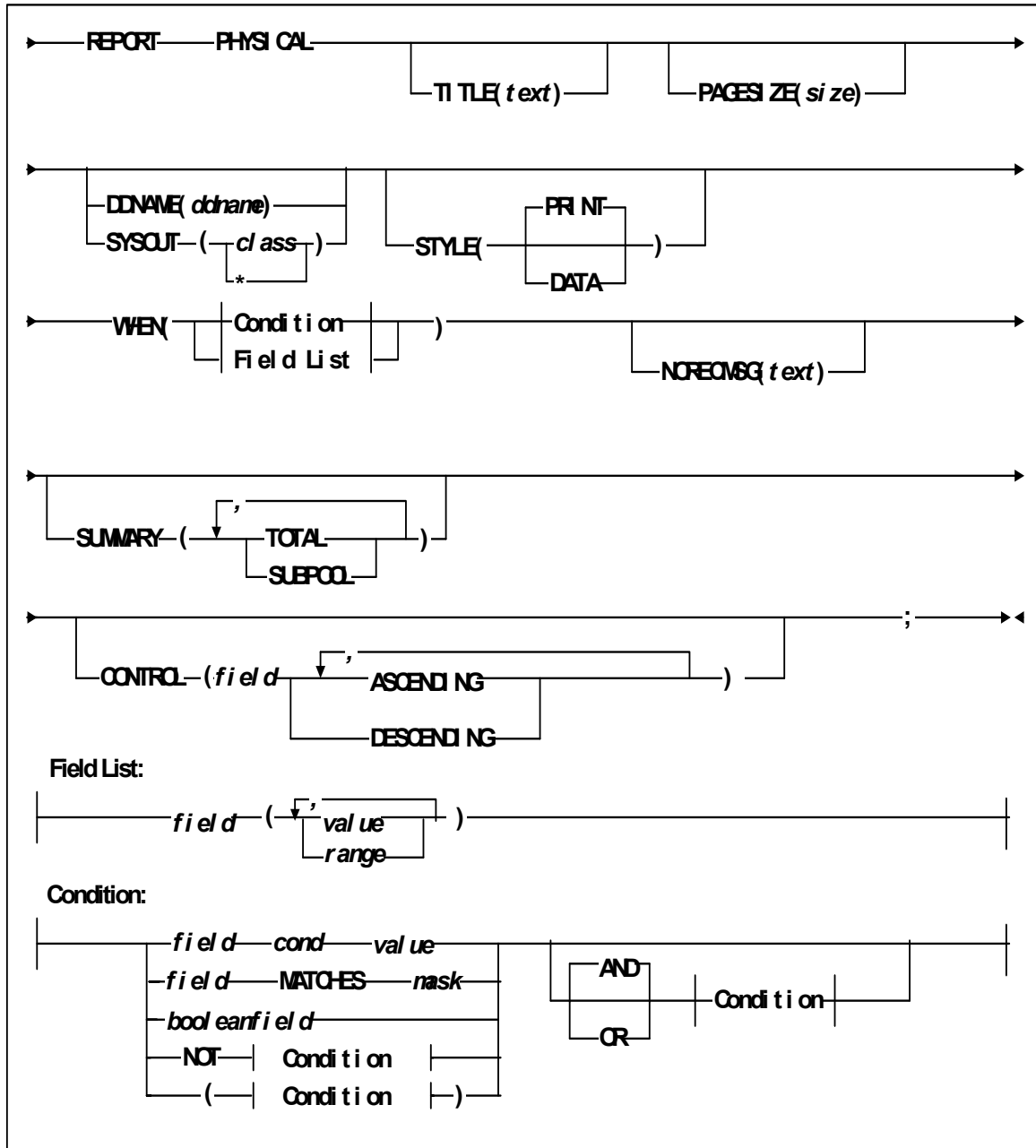

FIGURE 6-26 REPORT PHYSICAL Statement Syntax

Parameters

TITLE

specifies the title on each page of the report. The TITLE parameter of the OPTIONS statement defines a main title to be printed in the report headings. The title specified by the TITLE parameter of a REPORT statement is printed below this main title.

If you do not specify TITLE, the title is “Cell Count Report”.

text

the title, which is a maximum of 70 characters.

PAGESIZE

specifies the maximum lines per page for printing the report.

size

the maximum lines per page. Valid values are 20 to 1000. You can specify a default pagesize for all reports on the ExLM main program JCL EXEC statement. Otherwise, the default is 58.

Note – You must specify the same lines per page for all reports written to the same ddname.

DDNAME

specifies the ddname where ExLM writes the report.

DDNAME and SYSOUT are mutually exclusive. If you specify neither, ExLM writes the report to DDNAME(SYSPRINT).

ddname

the ddname.

SYSOUT

specifies that ExLM writes the report to the specified SYSOUT class.

DDNAME and SYSOUT are mutually exclusive. If you specify neither, ExLM writes the report to DDNAME(SYSPRINT).

class

the SYSOUT class: A through Z or 0 through 9 or * for the default output class for the job.

STYLE (PRINT | DATA | DATA CSV | DATA CSV TRIM)

specifies the report style.

PRINT

format the report for printing (include report titles and column headings).

Printed reports have the same DCB requirements as the other ExLM reports. See [“Using LCM to Manage Nearline Resources” on page 28](#) for more information about DCB attributes.

DATA

format the report for post processing without report titles and column headings. You can direct DATA reports to any data set with a RECFM of F, FB, V, or VB that has an LRECL large enough to accommodate an output line.

If you specify STYLE(DATA), you cannot specify the:

- PAGESIZE parameter,
- PAGE subparameter of the CONTROL parameter, and
- HEADING subparameter of the COLUMN parameter.

CSV

Presents the data in a Comma Separated Variable (CSV) format for entry into a spreadsheet.

TRIM

Deletes the trailing blanks of a metadata field.

WHEN(*condition*)

specifies one of the following for volume selection:

Field List

specifies the fields to use for volume selection. For a volume to be selected, the value for each *field* must match at least one of the provided *values* or *ranges*. The valid *values* depend on the type of *field* as described in [TABLE 6-13](#).

TABLE 6-16 Valid Types of Fields

Type	Values and Examples
Boolean	Specify TRUE or FALSE. FALSE is less than TRUE in comparisons.
Character or mixed character and integer string; also applies to ranges	Specify the string in single quotes. For example: WHEN(SERIAL('A00001')) WHEN(SERIAL('A00001'-'A99999'))
Date	Specify a date constant or MISSING. Date constants are of the form 'date'D or 'date'd where date can be specified in any date format defined in the "SET METHOD Statement WHEN Fields" section of <i>LCM Quick Reference</i> except TEXTDAYDATE. You must follow the format exactly. For example: '05Sep93'd is valid but '5Sep93'd is not.
Integer	Specify a number or MISSING. For example: 123
Time	Specify a time constant or MISSING. Time constants are of the form 'time'T where time can be specified in any time format defined in the "SET METHOD Statement WHEN Fields" section of <i>LCM Quick Reference</i> . You must follow the format exactly. For example: '12:30't is valid but '12;30't is not.

MISSING can also be specified as a period (“.”). MISSING is less than all other values.

TABLE 6-17 Valid Formats for Date Fields

Type	Size	Example
yyddd	5	97248
ccyyddd	7	1997248
yy.ddd	6	97.248
ccyy.ddd	8	1997.248
mm/dd/yy	8	09/05/97
mm/dd/ccyy	10	09/05/1997
yy-mm-dd	8	93-09-05
yyyy-mm-dd	10	2000-09-05 This is the default.
dd_mmm_yy	9	09 Sep 98
dd_mmm_ccyy	11	09 Sep 2000
ddmmmyy	7	09Sep98
ddmmccyy	9	09Sep1997
textdate	18	September 9, 2000
textdaydate	29	Wednesday, September 10, 2000

TABLE 6-18 Valid Formats for Time Fields

Type	Size	Example
hh:mm	5	22:21 This is the default.
hh:mm:ss	8	22:21:32
hh:mm:ss_pm	11	10:21:32 PM

Condition

specifies a condition for volume selection.

field cond value

specifies a field, a condition, and a value to compare with one of the following conditions:

EQ

equal to.

NE

not equal to.

GE

greater than or equal to.

GT

greater than.

LE

less than or equal to.

LT

less than.

For example, `VOLSER GE A00243` selects volsers greater than or equal to A00243.

field **MATCHES** *mask*

specifies a field and a mask for selection. The valid masks depend on the field selected:

■ **DATASETNAME, BASENAME:** Specify a string in single quotes. Wildcards can be used as follows:

“***” matches one or more data set qualifiers.

“*” matches one or more characters within a qualifier.

“%” matches one character within a qualifier.

■ **Other character fields:** Specify a string in single quotes. Wildcards can be used as follows:

“*” matches one or more characters.

“%” matches one character.

For example, `DataSetName MATCHES DR*` selects all data sets with HLQs beginning with DR.

booleanfield

specifies a Boolean field to be tested for TRUE. Specify NOT before the field if you want to test for FALSE.

For example, `CLN` selects volumes that are cleaning cartridges.

NOT

reverses the condition that immediately follows the NOT keyword.

For example, `NOT CLN` selects volumes that are **not** cleaning cartridges.

AND

make the selection if both conditions are true.

For example, `NOT CLN AND SERIAL(A00500-A00750)` selects volumes A00500 through A00750 that are **not** cleaning cartridges.

OR

make the selection if either condition is true. For example, `NOT CLN OR SERIAL(A00500-A00750)` selects volumes A00500 through A00750 **or** volumes that are not cleaning cartridges.

Note – For complete information on the fields available, their types, values, and use, see *LCM Quick Reference*.

NORECMSG

specifies the text to print if no records are printed on the report. The specified text prints where the first record would appear.

text

specifies the text to print, which is a maximum of 70 characters. The default text is 'No records to print for this report.'

SUMMARY

specifies one of the following report summaries:

TOTAL

specifies that totals of scratch, selected, errant, available cells, and external label status types be provided on an LSM, ACS, and library basis in the report.

SUBPOOL

specifies that subpool totals be provided on an LSM, ACS, and library basis in the report.

CONTROL

specifies the fields where breaks occur and the field sort order.

field

specifies a control field.

The volumes selected are sorted based on the control fields. You can use the **BREAK** subparameter to specify that a control break occurs when the value of a control field is different from the same field of the preceding volume.

You can specify the **HEADING**, **FOOTING**, and **SUMMARY | NOSUMMARY** subparameters before the first comma without coding a field name. This allows you to specify some text that is printed at the start of the report, at the end of the report, and just before the final summary line. Additionally, you can specify **NOSUMMARY** before the first comma to indicate that no final summary line is printed.

CONTROL (HEADING('Start of Report')

FOOTING('End of Report')

SUMMARY('Final Summary Line')

,

field ,

.

.

.

)

Control Attr

specifies control information for the preceding control field.

ASCENDING | DESCENDING

specifies whether to sort the report records in ascending or descending order.

BREAK

specifies that a control break occurs when the value of the field changes. A control break also occurs for a field if a previously specified field has a control break. You can specify any number of control breaks.

HEADING

specifies the control break heading printed at the beginning of the control break when the value of the field changes. **HEADING** assumes the **BREAK** parameter.

One or more substitution variables can be specified for the control break footing. Any of the fields in the “REPORT VOLUME Statement Fields” section of *ExLM Quick Reference* can be specified by placing the ampersand character (“&”) before the field and a period (“.”) after the field. The period is optional if the character immediately following the field is not an alphanumeric or national character. For example, &DATASETNAME. substitutes the value of DATASETNAME each time a control break occurs.

text

specifies the text for control break heading. Each text string will be printed on a separate line. You can use a null text string to print a blank line.

FOOTING

specifies the control break footing printed at the end of the control break when the value of the field changes. **FOOTING** assumes the **BREAK** parameter.

One or more substitution variables can be specified for the control break footing. Any of the fields in the “REPORT VOLUME Statement Fields” section of *LCM Quick Reference* can be specified by placing the ampersand character (“&”) before the field and a period (“.”) after the field. The period is optional if the character immediately following the field is not an alphanumeric or national character. For example, &DATASETNAME. substitutes the value of DATASETNAME each time a control break occurs.

text

specifies the text for control break footing. Each text string will be printed on a separate line. You can use a null text string to print a blank line.

PAGE

specifies that a page break occurs when the value of field changes. **PAGE** assumes the **BREAK** parameter.

One or more substitution variables can be specified for the control break footing. Any of the fields in the “REPORT VOLUME Statement Fields” section of *LCM Quick Reference* can be specified by placing the ampersand character (“&”) before the field and a period (“.”) after the field. The period is optional if the character immediately following the field is not an alphanumeric or national character. For example, &DATASETNAME. substitutes the value of DATASETNAME at the beginning of a page break.

text

specifies the page break text. To print a blank line, use the null (“”) text string. This *text* parameter is optional.

The **PAGE** text and the Report volume title print on the same line. If you specify a long **PAGE** text string and there is not enough room for a centered Report title, the **PAGE** text overlays the Report title.

Usage

The REPORT PHYSICAL, REPORT MULTIPLE, and REPORT VIRTUAL statements generate an expanded listing in the joblog showing the statements created for the appropriate Custom Report. You can copy the listing in the joblog to your LCMLIB, modify as desired, and submit. For more information, see [“REPORT Statement Templates” on page 15](#).

Note – REPORT PHYSICAL output has been updated to include a new column for MediaWarrantyLifewith a column heading of "MWL %". This field is added to the end of the detail line of the Report Physical.

REPORT VAULT

The REPORT VAULT statement specifies options for an MVC Report.

Syntax

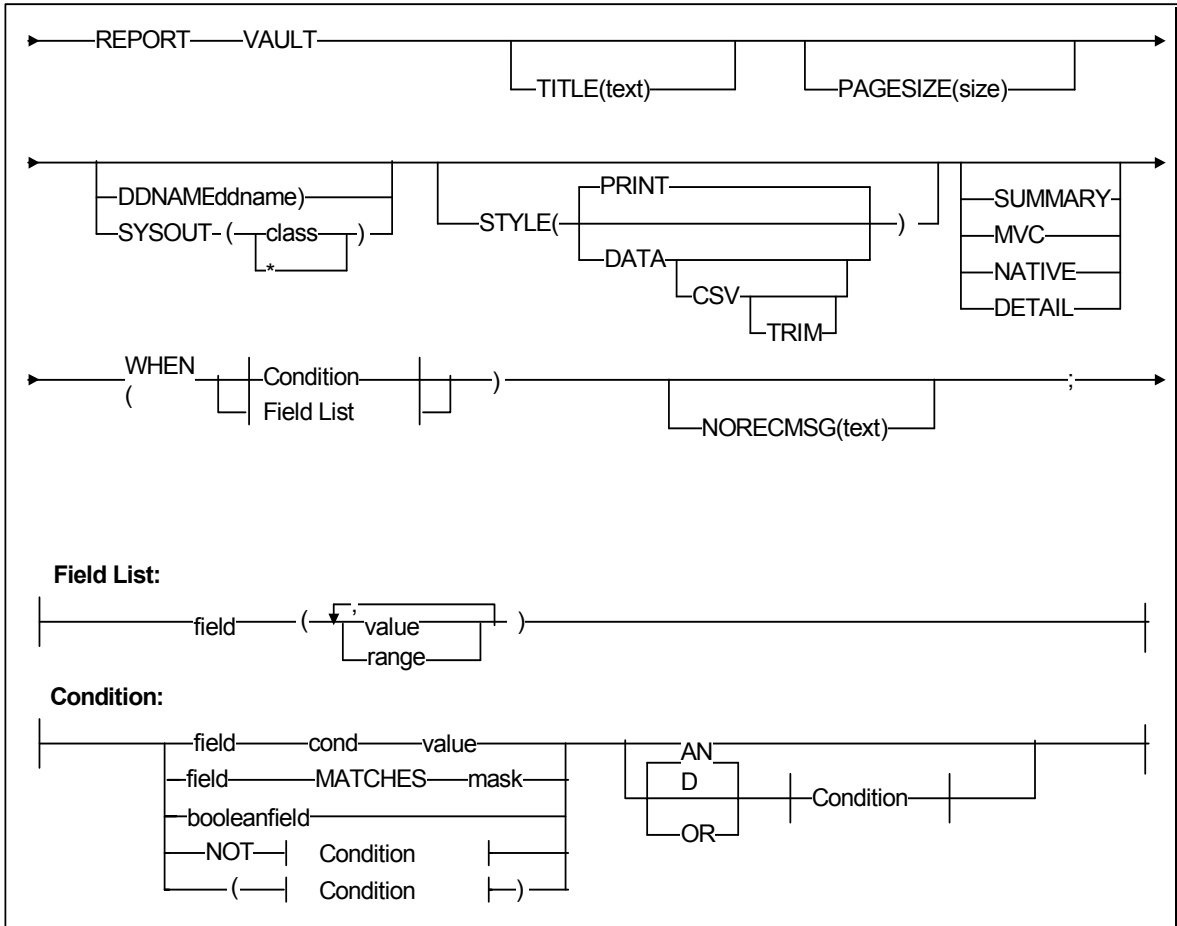

FIGURE 6-27 REPORT VAULT Statement Syntax

Parameters

TITLE

specifies the title on each page of the report. The TITLE parameter of the OPTIONS statement defines a main title to be printed in the report headings. The title specified by the TITLE parameter of a REPORT statement is printed below this main title.

If you do not specify TITLE, the title is “Cell Count Report”.

text

the title, which is a maximum of 70 characters.

PAGESIZE

specifies the maximum lines per page for printing the report.

size

the maximum lines per page. Valid values are 20 to 1000. You can specify a default pagesize for all reports on the ExLM main program JCL EXEC statement. Otherwise, the default is 58.

Note – You must specify the same lines per page for all reports written to the same ddname.

DDNAME

specifies the ddname where ExLM writes the report.

DDNAME and SYSOUT are mutually exclusive. If you specify neither, ExLM writes the report to DDNAME(SYSPRINT).

ddname

the ddname.

SYSOUT

specifies that ExLM writes the report to the specified SYSOUT class.

DDNAME and SYSOUT are mutually exclusive. If you specify neither, ExLM writes the report to DDNAME(SYSPRINT).

class

the SYSOUT class: A through Z or 0 through 9 or * for the default output class for the job.

STYLE (PRINT | DATA | DATA CSV | DATA CSV TRIM)

specifies the report style.

PRINT

format the report for printing (include report titles and column headings).

Printed reports have the same DCB requirements as the other ExLM reports. See [“Using LCM to Manage Nearline Resources” on page 28](#) for more information about DCB attributes.

DATA

format the report for post processing without report titles and column headings. You can direct DATA reports to any data set with a RECFM of F, FB, V, or VB that has an LRECL large enough to accommodate an output line.

If you specify STYLE(DATA), you cannot specify the:

- PAGESIZE parameter,
- PAGE subparameter of the CONTROL parameter, and
- HEADING subparameter of the COLUMN parameter.

CSV

Presents the data in a Comma Separated Variable (CSV) format for entry into a spreadsheet.

TRIM

Deletes the trailing blanks of a metadata field.

SUMMARY

produce a summary report (total MVCs, total native volumes in the vault).

DETAIL

produce a detailed report of MVCs in the vault, including:

- MVC volser and slot
- VTV volsers
- Block Id
- Management Class
- Date migrated

MVC

produce a report of MVCs in the vault, including:

- MVC volser and slot
- Vault name
- Block Id
- Vault assignment date
- Vault return date

NATIVE

produce a report of native volumes in the vault, including:

- MVC volser and slot
- Vault name
- Block Id
- Vault assignment date
- Vault return date

WHEN(*condition*)

specifies one of the following for volume selection:

Field List

specifies the fields to use for volume selection. For a volume to be selected, the value for each *field* must match at least one of the provided *values* or *ranges*. The valid *values* depend on the type of *field* as described in TABLE 6-13.

TABLE 6-19 Valid Types of Fields

Type	Values and Examples
Boolean	Specify TRUE or FALSE. FALSE is less than TRUE in comparisons.
Character or mixed character and integer string; also applies to ranges	Specify the string in single quotes. For example: WHEN(SERIAL('A00001')) WHEN(SERIAL('A00001'-'A99999'))
Date	Specify a date constant or MISSING. Date constants are of the form 'date'D or 'date'd where date can be specified in any date format defined in the "SET METHOD Statement WHEN Fields" section of <i>LCM Quick Reference</i> except TEXTDAYDATE. You must follow the format exactly. For example: '05Sep93'd is valid but '5Sep93'd is not.
Integer	Specify a number or MISSING. For example: 123
Time	Specify a time constant or MISSING. Time constants are of the form 'time'T where time can be specified in any time format defined in the "SET METHOD Statement WHEN Fields" section of <i>LCM Quick Reference</i> . You must follow the format exactly. For example: '12:30't is valid but '12;30't is not.

MISSING can also be specified as a period ("."). MISSING is less than all other values.

TABLE 6-20 Valid Formats for Date Fields

Type	Size	Example
yyddd	5	97248
ccyyddd	7	1997248
yy.ddd	6	97.248
ccyy.ddd	8	1997.248
mm/dd/yy	8	09/05/97
mm/dd/ccyy	10	09/05/1997
yy-mm-dd	8	93-09-05
yyyy-mm-dd	10	2000-09-05 This is the default.
dd_mmm_yy	9	09 Sep 98
dd_mmm_ccyy	11	09 Sep 2000
ddmmmyy	7	09Sep98

TABLE 6-20 Valid Formats for Date Fields

Type	Size	Example
ddmmmccyy	9	09Sep1997
textdate	18	September 9, 2000
textdaydate	29	Wednesday, September 10, 2000

TABLE 6-21 Valid Formats for Time Fields

Type	Size	Example
hh:mm	5	22:21 This is the default.
hh:mm:ss	8	22:21:32
hh:mm:ss_pm	11	10:21:32 PM

Condition

specifies a condition for volume selection.

field cond value

specifies a field, a condition, and a value to compare with one of the following conditions:

EQ

equal to.

NE

not equal to.

GE

greater than or equal to.

GT

greater than.

LE

less than or equal to.

LT

less than.

For example, `VOLSER GE A00243` selects volsers greater than or equal to A00243.

field MATCHES mask

specifies a field and a mask for selection. The valid masks depend on the field selected:

■ **DATASETNAME, BASENAME:** Specify a string in single quotes.

Wildcards can be used as follows:

“***” matches one or more data set qualifiers.

“*” matches one or more characters within a qualifier.

“%” matches one character within a qualifier.

■ **Other character fields:** Specify a string in single quotes. Wildcards can be used as follows:

“*” matches one or more characters.

“%” matches one character.

For example, `DataSetName MATCHES DR*` selects all data sets with HLQs beginning with DR.

booleanfield

specifies a Boolean field to be tested for TRUE. Specify NOT before the field if you want to test for FALSE.

For example, CLN selects volumes that are cleaning cartridges.

NOT

reverses the condition that immediately follows the NOT keyword.

For example, NOT CLN selects volumes that are **not** cleaning cartridges.

AND

make the selection if both conditions are true.

For example, NOT CLN AND SERIAL(A00500-A00750) selects volumes A00500 through A00750 that are **not** cleaning cartridges.

OR

make the selection if either condition is true. For example, NOT CLN OR SERIAL(A00500-A00750) selects volumes A00500 through A00750 **or** volumes that are not cleaning cartridges.

Note – For complete information on the fields available, their types, values, and use, see *LCM Quick Reference*.

NORECMMSG

specifies the text to print if no records are printed on the report. The specified text prints where the first record would appear.

text

specifies the text to print, which is a maximum of 70 characters. The default text is 'No records to print for this report.'

Usage

Note – The REPORT VAULT statement generates an expanded listing in the joblog which you can copy to your LCMLIB, modify as desired, and submit.

Vault Reports

Default Vault Report

```
2013-03-08                               StorageTek Library Content Manager 7.1                               Page 1
15:52:46                                                                                                         Report Vault                               VOLUME
```

Volume Serial	Vault Name	Vault Slot	Vault Assignment Date	Vault Return Date
010001	MVCVAULT	10	2013-01-02	
010004	MVCVAULT	41	2012-09-30	
010005	MVCVAULT	15	2013-02-03	
010006	MVCVAULT	796	2012-09-02	
010011	MVCVAULT	1328	2012-07-30	
010013	MVCVAULT	49	2013-02-01	
010014	MVCVAULT	1454	2012-08-01	
010015	MVCVAULT	126	2012-07-24	
:				
010843	MVCVAULT	883	2013-01-17	2013-02-08
010844	MVCVAULT	1408	2013-02-02	2013-02-08
010845	MVCVAULT	559	2013-01-02	
010848	MVCVAULT	2011	2013-01-31	2013-02-08
010853	MVCVAULT	2012	2013-01-31	2013-02-08
010854	MVCVAULT	760	2013-02-04	2013-02-08
:				
464112	MVCVAULT	2223	2013-01-16	
464113	MVCVAULT	2237	2013-01-16	
464114	MVCVAULT	2248	2013-01-16	
4000 Vault Slots available				
2297 Volumes in MVCVAULT				

FIGURE 6-28 Default Vault Report

Summary Vault Report

FIGURE 6-29 Summary Vault Report

```
2013-03-08                               StorageTek Library Content Manager 7.1                               Page 1
15:52:46                                                                                                         Report Vault Summary                               VOLUME
```

Summary for Vault MVCVAULT
Vault Slots in use 2297
Vault Slots available 4000

Total MVCs 2295
Total Native Volumes 2

FIGURE 6-30 Summary Vault Report

MVC Vault Report

```
2013-03-08                               StorageTek Library Content Manager 7.1                               Page 1
15:52:46                                                                                                         Report Vault for MVC                               VOLUME
```

Volume Serial	Vault Name	Vault Slot	Vault Assignment Date	Vault Return Date
463048	MVCVAULT	1272	2013-02-05	
:				
464049	MVCVAULT	2110	2013-01-16	
464051	MVCVAULT	2180	2013-01-05	
464052	MVCVAULT	2161	2013-02-03	2013-02-08
464083	MVCVAULT	2256	2013-02-03	
464084	MVCVAULT	2298	2013-02-03	2013-02-08

0 In Library MVCs Processed
2295 Non-Library MVCs Processed

FIGURE 6-31 MVC Vault Report

Native Volume Vault Report

2013-03-08 15:52:46		StorageTek Library Content Manager 7.1			Page 1
Report Vault for Native Volumes					VOLUME
Volume Serial	Vault Name	Vault Slot	Vault Assignment Date	Vault Return Date	
A00001	MVCVAULT	467	2012-08-01		
A06739	MVCVAULT	23	2013-02-26	2013-03-12	
4000 Vault slots available 2 Volumes in MVCVAULT					

FIGURE 6-32 Native Volume Vault Report

Detail Vault Report

2013-03-08 15:52:46		StorageTek Library Content Manager 7.1			Page 1
Report Vault for MVCs with detail					MVC_VTV
MVC 464114 is in slot 2248					
VTV Volser	Size (MB)	Block ID	Management Class	Migration Date	
983245					
986511					
987240					
989393					
989522					
991365					
994420					
995265					
995517					
995824					
995844					
995848					
996220					
996844					
997580					
997582					
997588					
998618					
998680					
998944					
998954					
:					
:					
999030					
999208					
562 VTVs Found for MVC:464114					

FIGURE 6-33 Detail Vault Report

REPORT VIRTUAL

The REPORT VIRTUAL statement specifies options for a VTV Report.

Syntax

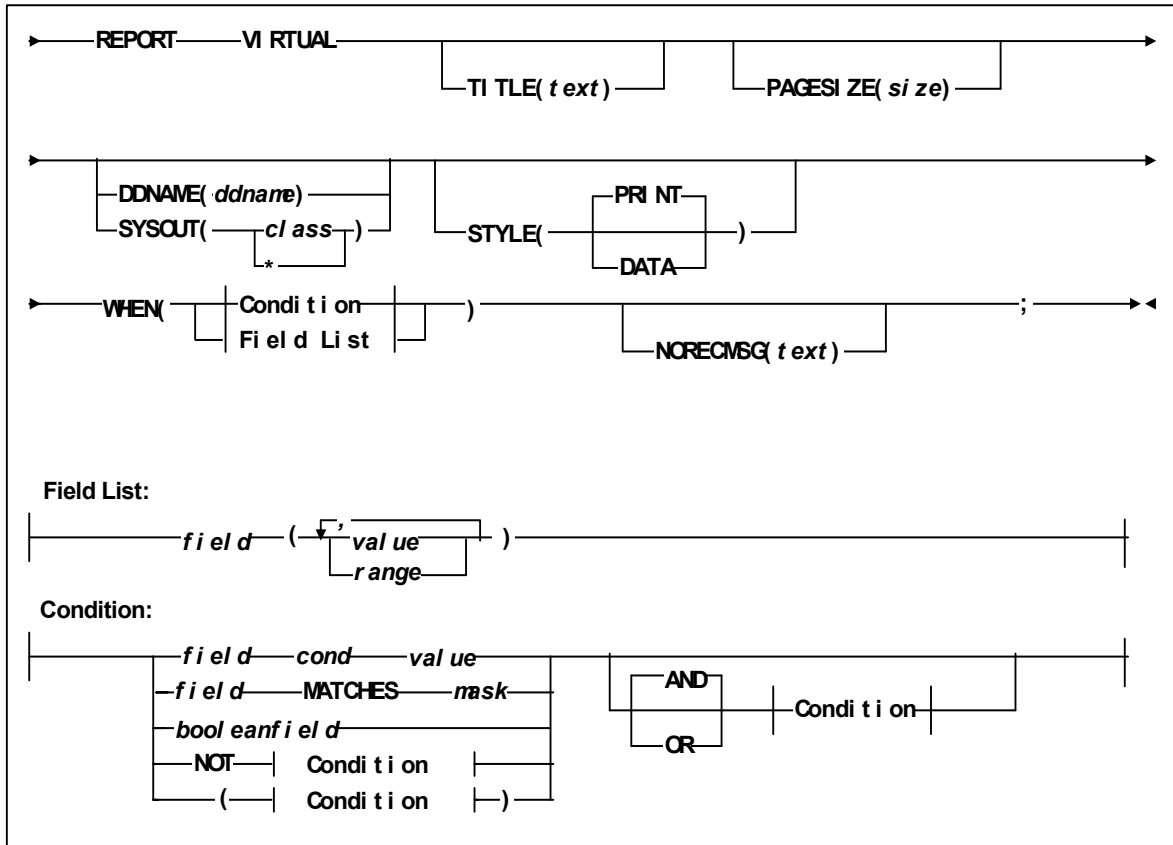

FIGURE 6-34 REPORT VIRTUAL Statement Syntax

Parameters

TITLE

specifies the title on each page of the report. The TITLE parameter of the OPTIONS statement defines a main title to be printed in the report headings. The title specified by the TITLE parameter of a REPORT statement is printed below this main title.

If you do not specify TITLE, the title is "Cell Count Report".

text

the title, which is a maximum of 70 characters.

PAGESIZE

specifies the maximum lines per page for printing the report.

size

the maximum lines per page. Valid values are 20 to 1000. You can specify a default pagesize for all reports on the ExLM main program JCL EXEC statement. Otherwise, the default is 58.

Note – You must specify the same lines per page for all reports written to the same ddname.

DDNAME

specifies the ddname where ExLM writes the report.

DDNAME and SYSOUT are mutually exclusive. If you specify neither, ExLM writes the report to DDNAME(SYSPRINT).

ddname

the ddname.

SYSOUT

specifies that ExLM writes the report to the specified SYSOUT class.

DDNAME and SYSOUT are mutually exclusive. If you specify neither, ExLM writes the report to DDNAME(SYSPRINT).

class

the SYSOUT class: A through Z or 0 through 9 or * for the default output class for the job.

STYLE (PRINT | DATA | DATA CSV | DATA CSV TRIM)

specifies the report style.

PRINT

format the report for printing (include report titles and column headings).

Printed reports have the same DCB requirements as the other ExLM reports. See [“Using LCM to Manage Nearline Resources” on page 28](#) for more information about DCB attributes.

DATA

format the report for post processing without report titles and column headings. You can direct DATA reports to any data set with a RECFM of F, FB, V, or VB that has an LRECL large enough to accommodate an output line.

If you specify STYLE(DATA), you cannot specify the:

- PAGESIZE parameter,
- PAGE subparameter of the CONTROL parameter, and
- HEADING subparameter of the COLUMN parameter.

CSV

Presents the data in a Comma Separated Variable (CSV) format for entry into a spreadsheet.

TRIM

Deletes the trailing blanks of a metadata field.

STYLE (PRINT | DATA)

specifies the report style.

PRINT

format the report for printing (include report titles and column headings).

Printed reports have the same DCB requirements as the other ExLM reports. See “Using ExLM to Manage Nearline Resources” on page 29 for more information about DCB attributes.

DATA

format the report for post processing without report titles and column headings. You can direct DATA reports to any data set with a RECFM of F, FB, V, or VB that has an LRECL large enough to accommodate an output line.

If you specify STYLE(DATA), you cannot specify the:

- PAGESIZE and LINESIZE parameters,
- PAGE subparameter of the CONTROL parameter, and
- HEADING subparameter of the COLUMN parameter.

CSV

output data in CSV format.

TRIM

delete trailing blanks in a metadata field.

WHEN(*condition*)

specifies one of the following for volume selection:

Field List

specifies the fields to use for volume selection. For a volume to be selected, the value for each *field* must match at least one of the provided *values* or *ranges*. The valid *values* depend on the type of *field* as described in [TABLE 6-13](#).

TABLE 6-22 Valid Types of Fields

Type	Values and Examples
Boolean	Specify TRUE or FALSE. FALSE is less than TRUE in comparisons.
Character or mixed character and integer string; also applies to ranges	Specify the string in single quotes. For example: WHEN(SERIAL('A00001')) WHEN(SERIAL('A00001'-'A99999'))
Date	Specify a date constant or MISSING. Date constants are of the form 'date'D or 'date'd where date can be specified in any date format defined in the "SET METHOD Statement WHEN Fields" section of <i>LCM Quick Reference</i> except TEXTDAYDATE. You must follow the format exactly. For example: '05Sep93'd is valid but '5Sep93'd is not.
Integer	Specify a number or MISSING. For example: 123
Time	Specify a time constant or MISSING. Time constants are of the form 'time'T where time can be specified in any time format defined in the "SET METHOD Statement WHEN Fields" section of <i>LCM Quick Reference</i> . You must follow the format exactly. For example: '12:30't is valid but '12;30't is not.

MISSING can also be specified as a period ("."). MISSING is less than all other values.

TABLE 6-23 Valid Formats for Date Fields

Type	Size	Example
yyddd	5	97248
ccyyddd	7	1997248
yy.ddd	6	97.248
ccyy.ddd	8	1997.248
mm/dd/yy	8	09/05/97
mm/dd/ccyy	10	09/05/1997
yy-mm-dd	8	93-09-05
yyyy-mm-dd	10	2000-09-05 This is the default.
dd_mmm_yy	9	09 Sep 98
dd_mmm_ccyy	11	09 Sep 2000
ddmmmyy	7	09Sep98
ddmmccyy	9	09Sep1997
textdate	18	September 9, 2000
textdaydate	29	Wednesday, September 10, 2000

TABLE 6-24 Valid Formats for Time Fields

Type	Size	Example
hh:mm	5	22:21 This is the default.
hh:mm:ss	8	22:21:32
hh:mm:ss_pm	11	10:21:32 PM

Condition

specifies a condition for volume selection.

field cond value

specifies a field, a condition, and a value to compare with one of the following conditions:

EQ

equal to.

NE

not equal to.

GE

greater than or equal to.

GT

greater than.

LE

less than or equal to.

LT

less than.

For example, `VOLSER GE A00243` selects volsers greater than or equal to A00243.

field MATCHES mask

specifies a field and a mask for selection. The valid masks depend on the field selected:

■ **DATASETNAME, BASENAME:** Specify a string in single quotes.

Wildcards can be used as follows:

“***” matches one or more data set qualifiers.

“*” matches one or more characters within a qualifier.

“%” matches one character within a qualifier.

■ **Other character fields:** Specify a string in single quotes. Wildcards can be used as follows:

“*” matches one or more characters.

“%” matches one character.

For example, `DataSetName MATCHES DR*` selects all data sets with HLQs beginning with DR.

booleanfield

specifies a Boolean field to be tested for TRUE. Specify NOT before the field if you want to test for FALSE.

For example, CLN selects volumes that are cleaning cartridges.

NOT

reverses the condition that immediately follows the NOT keyword.

For example, NOT CLN selects volumes that are **not** cleaning cartridges.

AND

make the selection if both conditions are true.

For example, NOT CLN AND SERIAL(A00500-A00750) selects volumes A00500 through A00750 that are **not** cleaning cartridges.

OR

make the selection if either condition is true. For example, NOT CLN OR SERIAL(A00500-A00750) selects volumes A00500 through A00750 **or** volumes that are not cleaning cartridges.

Note – For complete information on the fields available, their types, values, and use, see *LCM Quick Reference*.

NORECMMSG

specifies the text to print if no records are printed on the report. The specified text prints where the first record would appear.

text

specifies the text to print, which is a maximum of 70 characters. The default text is 'No records to print for this report.'

Usage

The REPORT PHYSICAL, REPORT MULTIPLE, and REPORT VIRTUAL statements generate an expanded listing in the joblog showing the statements created for the appropriate Custom Report. You can copy the listing in the joblog to your LCMLIB, modify as desired, and submit. For more information, see [“REPORT Statement Templates” on page 15](#).

Custom Reports

Custom Reports, which must be explicitly requested, provide both a wide range of selection criteria and output formats that can be ordered and sorted in many ways. The Custom Reports are produced via the following statements:

- [“REPORT LSM” on page 354](#)
- [“REPORT MVC_VTV” on page 356](#)
- [“REPORT VOLUME” on page 358](#)

The Custom Reports provide report templates that you can use as is or customize. For more information, see [“REPORT Statement Templates” on page 15](#).

REPORT LSM

The REPORT LSM statement produces a custom LSM Report.

Syntax - REPORT LSM

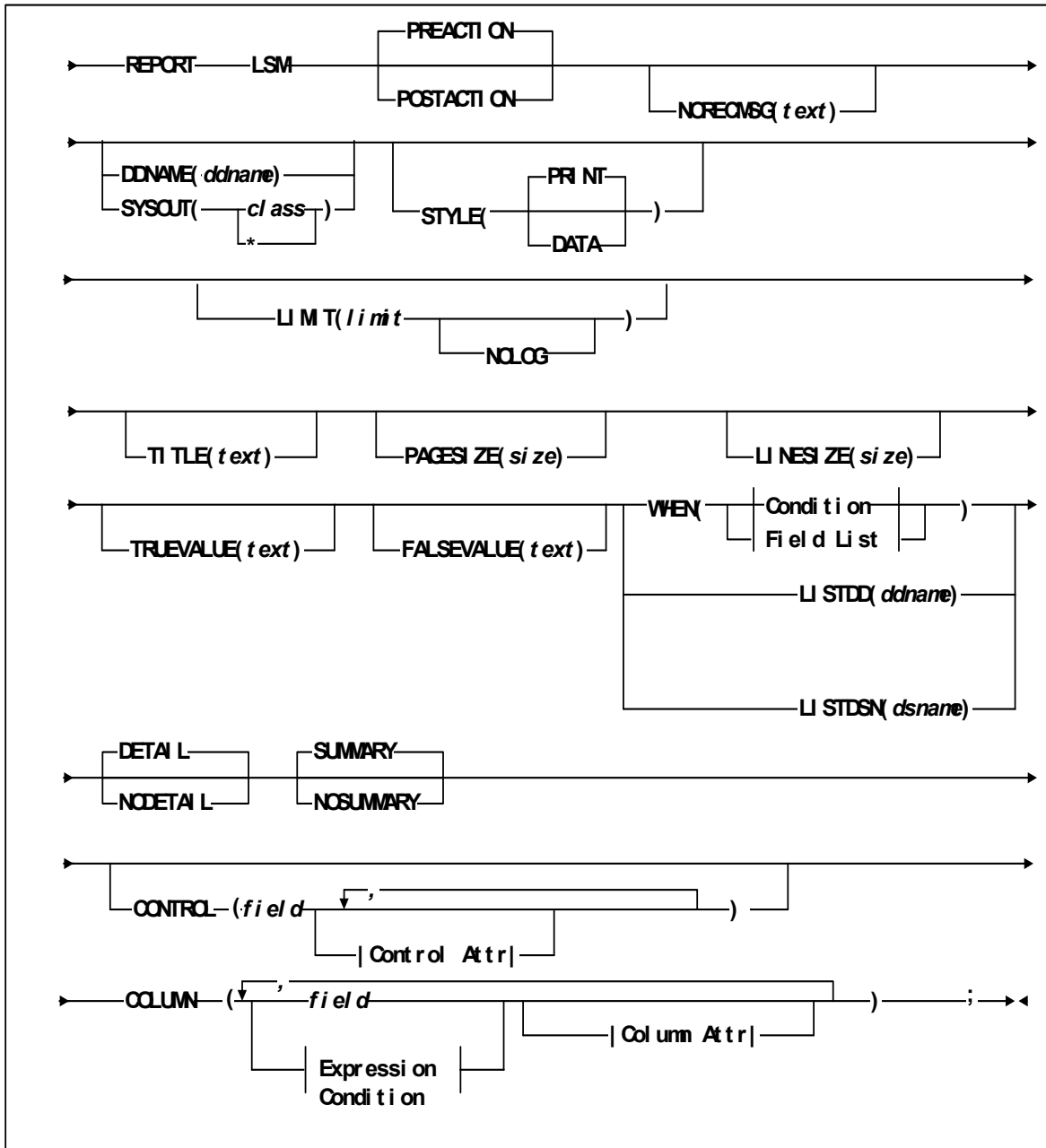

FIGURE 6-35 REPORT LSM Statement Syntax - Part 1

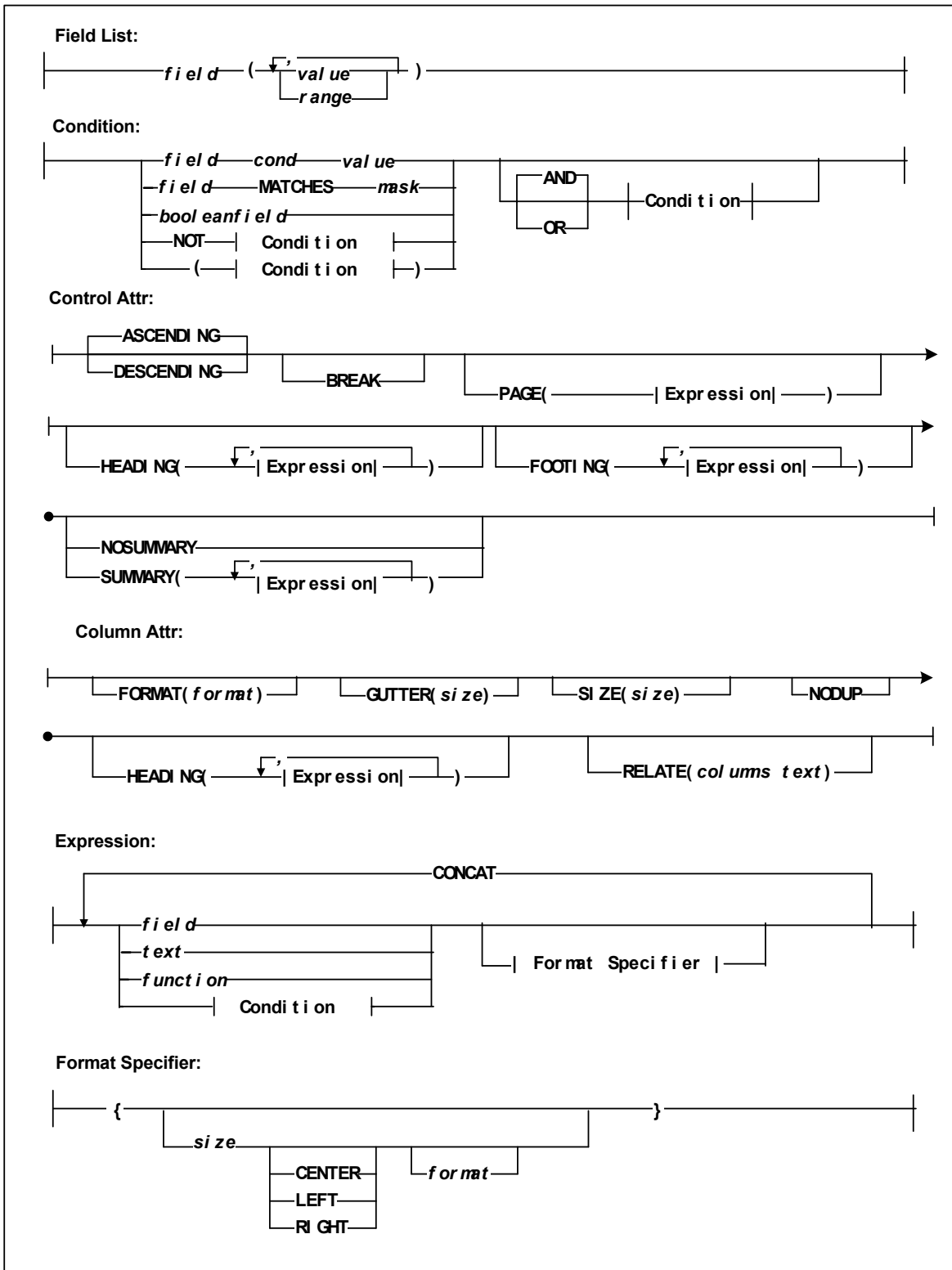

FIGURE 6-36 REPORT LSM Statement Syntax - Part 2

REPORT MVC_VTV

The REPORT MVC_VTV statement produces a custom MVC/VTV Report.

Syntax - REPORT MVC_VTV

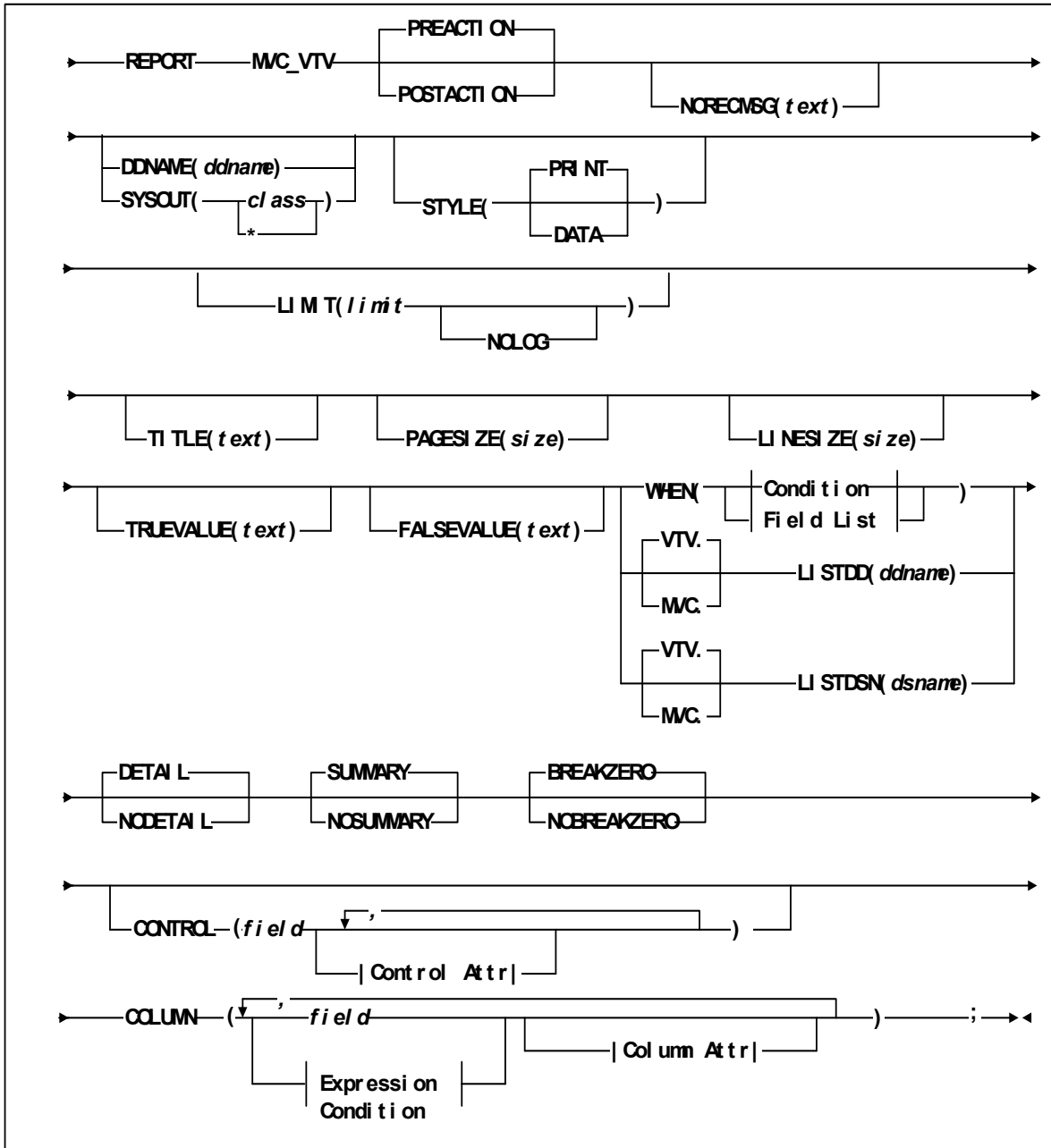

FIGURE 6-37 REPORT MVC_VTV Statement Syntax - Part 1

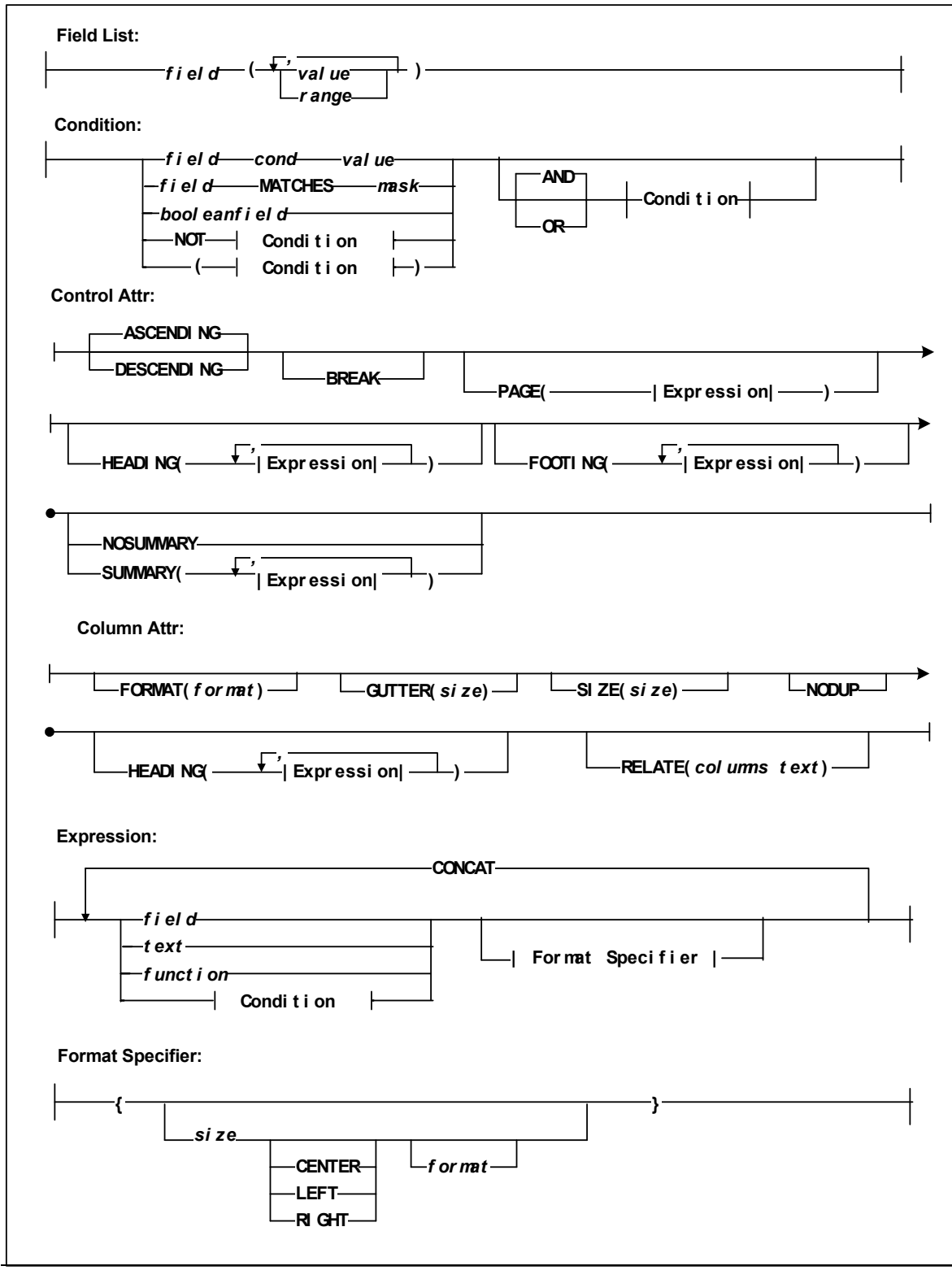

FIGURE 6-38 REPORT MVC_VTV Statement Syntax - Part 2

REPORT VOLUME

The REPORT VOLUME statement produces a custom Volume Report.

Syntax - REPORT VOLUME

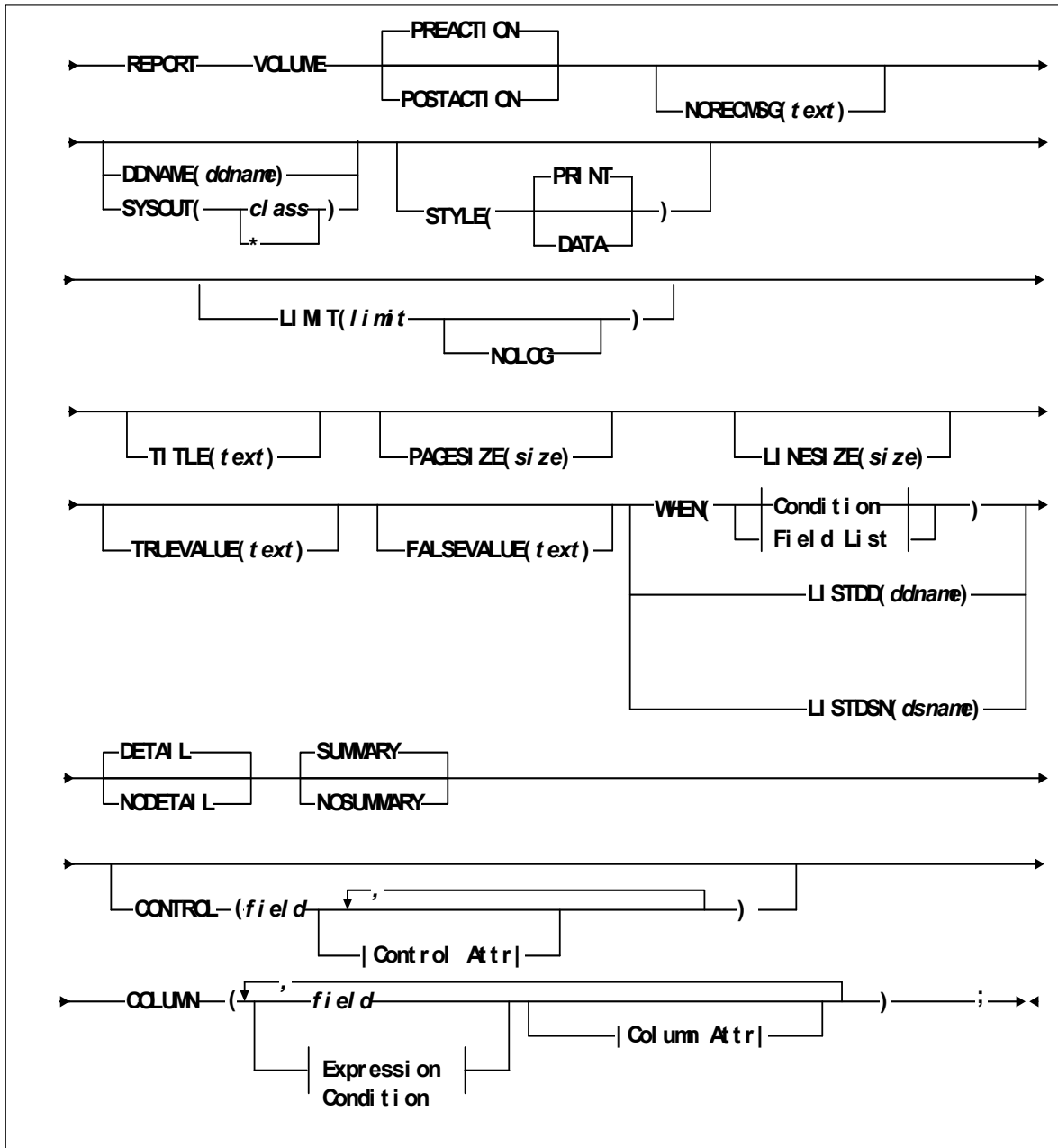

FIGURE 6-39 REPORT VOLUME Statement Syntax - Part 1

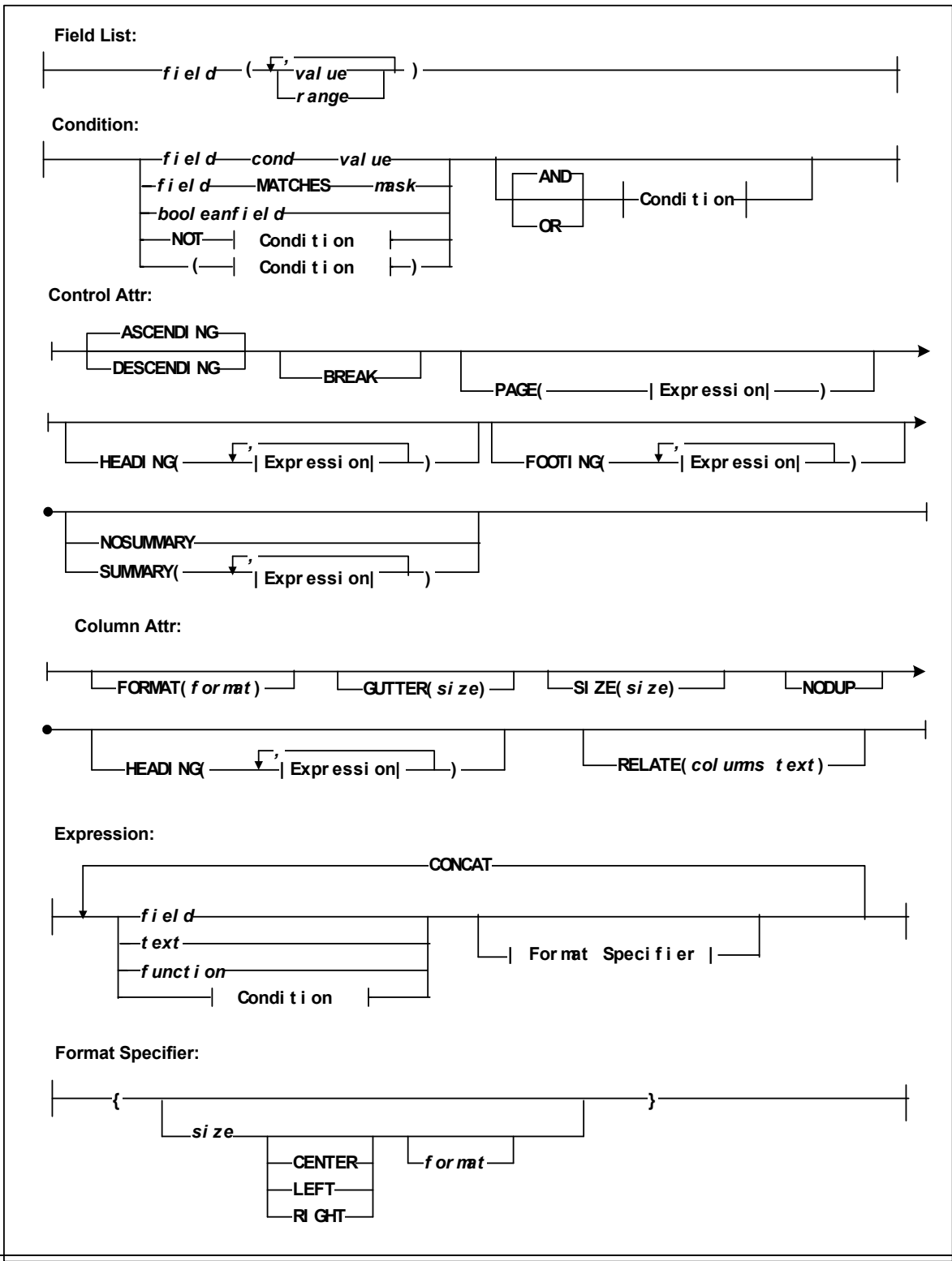

FIGURE 6-40 REPORT VOLUME Statement Syntax - Part 2

Custom Report Parameters

Table 6-25 lists the valid abbreviations for the Custom Reports.

TABLE 6-25 Custom Report Statement Abbreviations

Statement or Parameter	Abbreviation
REPORT	RPT
DDNAME	DD,DDN
EQ	=
GE	>=
GT	>
LE	<=
LT	<
NE	≠
NOT	¬
AND	&
OR	
CONCAT	

PREACTION | POSTACTION

specifies whether ExLM produces the report before or after volume ejects, moves, and consolidations.

If you specify PREACTION, the report's success and failure related fields show a - (missing value) because no action has occurred, but fields describing planned actions have values.

If you specify POSTACTION, all report fields have values. POSTACTION reports require a different ddname than PREACTION reports.

NORECMMSG

specifies the text to print if no records are printed on the report. The specified text prints where the first record would appear.

text

specifies the text to print, which is a maximum of 70 characters. The default text is 'No records to print for this report.'

DDNAME

specifies the ddname where ExLM writes the report.

DDNAME and SYSOUT are mutually exclusive. If you specify neither, ExLM writes the report to DDNAME(SYSPRINT).

ddname

the ddname.

SYSOUT

specifies that ExLM writes the report to the specified SYSOUT class.

DDNAME and SYSOUT are mutually exclusive. If you specify neither, ExLM writes the report to DDNAME(SYSPRINT).

class

the SYSOUT class: A through Z or 0 through 9 or * for the default output class for the job.

STYLE (PRINT | DATA)

specifies the report style.

PRINT

format the report for printing (include report titles and column headings).

Printed reports have the same DCB requirements as the other ExLM reports. See "Using LCM to Manage Nearline Resources" on page 28 for more information about DCB attributes.

DATA

format the report for post processing without report titles and column headings. You can direct DATA reports to any data set with a RECFM of F, FB, V, or VB that has an LRECL large enough to accommodate an output line.

If you specify STYLE(DATA), you cannot specify the:

- PAGESIZE and LINESIZE parameters,
- PAGE subparameter of the CONTROL parameter, and
- HEADING subparameter of the COLUMN parameter.

LIMIT

specifies the maximum number of volumes processed by this statement. The limit is applied based on the sort order established by the CONTROL parameter.

limit

specify a number between 1 and 999999.

NOLOG

specifies that ExLM does not issue message LCM2317.

TITLE

specifies the title on each page of the report. The TITLE parameter of the OPTIONS statement defines a main title to be printed in the report headings. The title specified by the TITLE parameter of a REPORT statement is printed below this main title.

If you do not specify TITLE, the title is "Volume", "LSM", or "MVC_VTV".

text

the title, which is a maximum of 70 characters.

PAGESIZE

specifies the maximum lines per page for printing the report.

size

the maximum lines per page. Valid values are 20 to 1000. You can specify a default pagesize for all reports on the ExLM main program JCL EXEC statement. Otherwise, the default is 58.

Note – You must specify the same lines per page for all reports written to the same ddname.

LINESIZE

specifies the maximum line size for printing the report.

size

the maximum line size. Valid values are 72 to 250, the default is 132.

Note – The LINESIZE parameter is only valid if you specify STYLE(PRINT).

TRUEVALUE

specifies the text to print for fields that have a Boolean value of TRUE.

text

specifies the text, which is a maximum of 20 characters. The default is specified by the OPTIONS statement TRUEVALUE parameter.

FALSEVALUE

specifies the text to print for fields that have a Boolean value of FALSE.

text

specifies the text, which is a maximum of 20 characters. The default is specified by the OPTIONS statement FALSEVALUE parameter.

WHEN(*condition*)

specifies one of the following for volume selection:

Field List

specifies the fields to use for volume selection. For a volume to be selected, the value for each *field* must match at least one of the provided *values* or *ranges*.

Condition

specifies a condition for volume selection.

field cond value

specifies a field, a condition, and a value to compare with one of the following conditions:

EQ

equal to.

NE

not equal to.

GE

greater than or equal to.

GT

greater than.

LE

less than or equal to.

LT

less than.

For example, `VOLSER GE A00243` selects volsers greater than or equal to A00243.

field MATCHES *mask*

specifies a field and a mask for selection. The valid masks depend on the field selected:

- **DATASETNAME, BASENAME:** Specify a string in single quotes. Wildcards can be used as follows:
 - “***” matches one or more data set qualifiers.
 - “*” matches one or more characters within a qualifier.
 - “%” matches one character within a qualifier.
- **Other character fields:** Specify a string in single quotes. Wildcards can be used as follows:
 - “*” matches one or more characters.
 - “%” matches one character.

For example, `DataSetName MATCHES DR*` selects all data sets with HLQs beginning with DR.

booleanfield

specifies a Boolean field to be tested for TRUE. Specify NOT before the field if you want to test for FALSE.

For example, `CLN` selects volumes that are cleaning cartridges.

NOT

reverses the condition that immediately follows the NOT keyword.

For example, `NOT CLN` selects volumes that are **not** cleaning cartridges.

AND

make the selection if both conditions are true.

For example, `NOT CLN AND VOLSEQ(A00500-A00750)` selects volumes A00500 through A00750 that are **not** cleaning cartridges.

OR

make the selection if either condition is true.

For example, `NOT CLN OR VOLSEQ(A00500-A00750)` selects volumes A00500 through A00750 **or** volumes that are not cleaning cartridges.

Note – For complete information on the fields available, their types, values, and use, see *LCM Quick Reference*.

LISTDD

the DD name of a file containing volsers for selection.

ddname

the ddname.

LISTDSN

the data set name of a file containing volsers for selection.

dsname

the data set name.

Note – In the files specified on LISTDD or LISTDSN:

- For the LSM report, the file should contain an LSMID in the first 5 columns of each record (aa:ll).
- The other reports expect a volsers in the first 6 columns. Each volsers must start in column 1 on a new line.
- For REPORT MVC_VTV, you must qualify LISTDD/LISTDSN with 'MVC.' or 'VTV.' to specify whether volumes are MVCs or VTVs.
- For REPORT LSM or REPORT MVC_VTV, the volsers are for any volume.
- Volumes listed in a LISTDD or LISTDSN file that are not eligible for selection in the statement are not used. For example, if the statement specifies a file that lists volsers 397261, 397263, 397266 and 397263 does not reside in an LSM, it is not used.

DETAIL | NODETAIL

specifies whether the report includes detail records.

A detail record contains the information specified by the COLUMN parameter for one volume. When you specify DETAIL, the report includes one detail record for each volume selected by the WHEN condition.

Note – At least one of the DETAIL or SUMMARY parameters must be in effect.

SUMMARY | NOSUMMARY

specifies whether the report includes summary records.

SUMMARY specifies that the report includes summary records at the end of a control break to summarize the detail records contained within that control break.

You can override the SUMMARY parameter with the NOSUMMARY subparameter of the CONTROL parameter (and vice versa).

There are four summary types associated with fields for this report:

None

specifies that summary information is not applicable for the field.

Sum

specifies that a standard addition of each reported detail record will be reported. Missing fields will count as 0.

Average

specifies that the average of each reported detail record is reported. Missing fields do not count toward the average.

True

specifies that the count of all Boolean "true" records will be reported.

BREAKZERO | NOBREAKZERO

This parameter only applies to MVC_VTV reports and only if the first control field is MVC.serial or VTV.serial and specifies whether a page break occurs for volumes that are not paired.

BREAKZERO (the default) specifies that a control break occurs for volumes that are not paired with any other volumes. This creates a break summary listing information for volumes that would otherwise not appear on the report.

If BREAKZERO is specified and the first control field is MVC.serial, a break will occur if there are zero VTVs for an MVC. If BREAKZERO is specified and the first control field is VTV.serial, a break will occur if there are zero MVCs for a VTV.

The example below requests a page break when the MVC serial changes. For empty MVCs, the page heading lists the MVC, there are no detail lines, and the footing lists 0 as the number of VTVs on the MVC.

```
report mvc_vtv breakzero
control(mvc.volser
page('mvc ' || mvc.volser)
footing(break_count(vtv.volser)
|| ' vtv's for mvc '
|| mvc.volser)
) ...
```

If the above example specifies NOBREAKZERO, empty MVCs are not included in the report.

CONTROL

specifies the fields where breaks occur and the field sort order.

field

specifies a control field.

The volumes selected are sorted based on the control fields. You can use the BREAK subparameter to specify that a control break occurs when the value of a control field is different from the same field of the preceding volume.

You can specify the HEADING, FOOTING, and SUMMARY | NOSUMMARY subparameters before the first comma without coding a field name. This allows you to specify some text that is printed at the start of the report, at the end of the report, and just before the final summary line. Additionally, you can specify NOSUMMARY before the first comma to indicate that no final summary line is printed.

```
CONTROL ( HEADING('Start of Report')
```

```
FOOTING('End of Report')
```

```
SUMMARY('Final Summary Line')
```

```
,  
field ,
```

```
.
```

```
.
```

```
.
```

```
)
```

Control Attr

specifies control information for the preceding control field.

ASCENDING | DESCENDING

specifies whether to sort the report records in ascending or descending order.

BREAK

specifies that a control break occurs when the value of the field changes. A control break also occurs for a field if a previously specified field has a control break. You can specify any number of control breaks.

PAGE

specifies that a page break occurs when the value of field changes. **PAGE** assumes the **BREAK** parameter.

One or more substitution variables can be specified for the control break footing. Any of the fields in the “REPORT VOLUME Statement Fields” section of *ExLM Quick Reference* can be specified by including the full name without quotes. You can use the **CONCAT** or **||** parameter to intersperse text and substitution variables.

For example, 'Location' || locationname would print the string 'Location' followed by the contents of the field locationname at the time of the break.

Expression

specifies an expression used to create the text.

HEADING

specifies the control break heading printed at the beginning of the control break when the value of the field changes. **HEADING** assumes the **BREAK** parameter.

One or more substitution variables can be specified for the control break footing. Any of the fields in the “REPORT VOLUME Statement Fields” section of *ExLM Quick Reference* can be specified by including the full name without quotes. You can use the **CONCAT** or **||** parameter to intersperse text and substitution variables.

For example, 'Location' || locationname would print the string 'Location' followed by the contents of the field locationname at the time of the break.

Expression

specifies an expression used to create the text.

FOOTING

specifies the control break footing printed at the end of the control break when the value of the field changes. **FOOTING** assumes the **BREAK** parameter.

One or more substitution variables can be specified for the control break footing. Any of the fields in the “REPORT VOLUME Statement Fields” section of *ExLM Quick Reference* can be specified by including the full name without quotes. You can use the **CONCAT** or **||** parameter to intersperse text and substitution variables.

For example, 'Location' || locationname would print the string 'Location' followed by the contents of the field locationname at the time of the break.

Expression

specifies an expression used to create the text.

SUMMARY | NOSUMMARY

specifies whether the report includes summary records.

SUMMARY specifies that the report includes summary records at the end of a control break to summarize the detail records contained within that control break.

You can override the **SUMMARY** parameter with the **NOSUMMARY** subparameter of the **CONTROL** parameter (and vice versa).

Expression

specifies an expression used to create the text.

COLUMN

specifies the report columns. You can specify an unlimited number of report columns as long as they do not exceed **LINESIZE**. This includes column headings as well as detail and summary records. The columns appear in the order that you specify them.

field

specifies the field to include as a column. See the “REPORT VOLUME Statement Fields” section of *ExLM Quick Reference* for field names, aliases, types, sizes, descriptions, summary types, sources, and default headings.

Expression

specifies an expression used to create the text.

Condition

When a condition is specified for a report column (see “WHEN(condition)” on page 89), each volume included in the report is evaluated using the specified condition and the results are printed in the report column.

A condition evaluates to a value of **TRUE** or **FALSE**. When printed on the report, the text supplied by **TRUEVALUE** and **FALSEVALUE** is used to represent the value of the condition. The defaults are “**YES**” and “**NO**”, respectively.

Column Attr

specifies additional column formatting attributes.

FORMAT

specifies a special output format for a field. The valid format types, default output sizes, and examples are listed in the following tables.

TABLE 6-26 Valid Formats for Date Fields

Type	Size	Example
yyddd	5	97248
ccyyddd	7	1997248
yy.ddd	6	97.248
ccyy.ddd	8	1997.248
mm/dd/yy	8	09/05/97
mm/dd/ccyy	10	09/05/1997
yy-mm-dd	8	97-09-05
yyyy-mm-dd	10	2000-09-05 This is the default.
dd_mmm_yy	9	09 Sep 97

TABLE 6-26 Valid Formats for Date Fields

Type	Size	Example
dd_mmm_ccyy	11	09 Sep 1997
ddmmyy	7	09Sep98
ddmmccyy	9	09Sep1997
textdate	18	September 9, 1997
textdaydate	29	Wednesday, September 10, 1997

TABLE 6-27 Valid Formats for Time Fields

Type	Size	Example
hh:mm	5	22:21
hh:mm:ss	8	22:21:32 This is the default.
hh:mm:ss_pm	11	10:21:32 PM

GUTTER

specifies the gutter size between columns.

size

the gutter size in spaces. Valid values are 1 to 100. If you specify STYLE(PRINT), the default gutter is 0 for the first column and 2 for the other columns. The default gutter is always 0 for STYLE(DATA).

SIZE

specifies the width of the column in spaces. Valid values are 1 to 100. If the column data is wider than the width, ExLM truncates the data as shown in Table 6-28.

TABLE 6-28 Column Truncation Actions

Type	Truncation Results
INT	Fill field with asterisks “*”
CHAR	Print “+” in last printable position
BOOL	Truncate
<i>text</i>	Truncate
DATE	Truncate
TIME	Truncate

NODUP

specifies that, with the exception of the first record in a control break, this column is blank until its value changes or until a control break occurs.

Detail records at the beginning of a control break are not affected by NODUP.

HEADING

specifies the column heading.

Expression

specifies an expression used to create the text.

Note – There is no default heading for expression and condition columns.

RELATE

specifies the number of columns, beginning with the current one, that should be tied together under a common header.

columns

the number of columns to relate

text

the text to place over the related column headings. The relate text is always printed on the first line of the headings.

The relate text can be as long as the cell sizes of all the related columns plus the gutters between them.

Expression

specifies an expression used to create the text.

field

the field to use.

text

a quoted string supplying the text to use.

function

an ExLM report function. The following ExLM report functions insert text based on parameters you specify.

SWITCH(Condition , Expression)

Function SWITCH returns the first Expression that follows a true Condition. If no conditions are true, an empty string is returned.

Specify TRUE as the last condition if you want to return an Expression when all previous conditions are false.

Note – The following functions are only permitted in CONTROL parameters FOOTING and SUMMARY. They provide summary values for the corresponding break.

BREAK_SUM(*field*)

Valid for numeric fields. Returns the sum of the values for the field. Missing values are ignored when computing the sum.

BREAK_AVG(*field*)

Valid for numeric fields. Returns the average of the values for the field. Missing values are ignored when computing the average.

BREAK_COUNT(*field*)

Valid for all fields. Returns the following count:

- For conditions and boolean fields this is the count of true values.
- For character fields this is the count of non blank values.

- For integer, date, and time fields, the count is the number of non-missing values.

`BREAK_MIN(field)`

Valid for all fields. Returns the minimum value of the field.

Missing values are ignored. For character, values that are all binary zeros or spaces are also ignored. For boolean, FALSE is less than TRUE.

`BREAK_MAX(field)`

Valid for all fields. Returns the maximum value of the field.

Missing values are ignored. For character, values that are all binary zeros or spaces are also ignored. For boolean, FALSE is less than TRUE.

Condition

specifies a condition for selection.

Format Specifier

specifies the format.

size

specifies the length of the output space for this value.

LEFT | CENTER | RIGHT

specifies how the value should be justified within the formatted space.

format

specifies the format to use.

The formats available are the same as for the COLUMN FORMAT parameter.

If a format specifier is not provided, the default is trimmed using the default format.

If format specifier is specified with size but without justification, the default is right for integer and left for everything else.

CONCAT

concatenates two text strings.

CONCAT can also be specified as "||".

Custom Report Fields

The information found in the “REPORT VOLUME Statement Fields” or “REPORT LSM Statement Fields” section of *LCM Quick Reference* allows you to tailor the Volume Report to fit your specific needs. The information found in the table is divided into the following four areas:

- Field
- Type/Size/Summary/Source
- Heading
- Description

where;

Field

These are the choices you specify within the report to display information. For example, if you want to report on the actions taken against each volume reported on, you would specify ACTION as a field on the parameter file for the Volume report.

Type/Size/Summary/Source

This column displays four types of information regarding the corresponding field:

- i. TYPE --- displays the type of information displayed according to the demands of the field selected. Type may be any of the following:
 - Boolean (BOOL)
 - Character (CHAR)
 - Date (DATE)
 - Integer (INT)
 - Time (TIME)

The ACTION field has a TYPE of CHAR, showing that the expected output is a character string.

- ii. SIZE --- displays the number of spaces required for the output of the corresponding field. This is either a set number or a variable number if the output is not constant.

The ACTION field has a SIZE of 10, showing that the expected output is no more than ten digits.

- iii. SUMMARY --- displays whether the corresponding field generates summary records. Summary information is written at the end of a control break to summarize detail records within the control break. Possible summary types are:

- None, no summary records available
- Sum, standard summary records are produced
- Average, the average of available summary records is produced
- True, the count of all Boolean “true” records is produced

The ACTION field has a SUMMARY of None showing that the ACTION field does not generate summary records.

- iv. SOURCE --- shows the location from which the requested information is gathered. Field sources include:
- HSC, information is received from the HSC CDS
 - VSM
 - TMS, information is received from your TMS
 - LCM, information is computed by LCM
 - Specific TMSs such as CA-1. For more information, see the Field Tables section for your TMS in *LCM Quick Reference*.

Heading

Shows the heading that is written at the top of the column for the field selected.

The ACTION field has a HEADING of "Action". This is written at the top of the column on each page of the report.

Description

Shows the possible output displayed in the column for the field selected. This description explains the output expected to be produced and displayed when this field is specified in the report parameter file.

The ACTION field has a description specifying that one of the following actions was taken on the specific volume:

- None
- Consolidate
- Eject (volume ejected)
- Move (volume moved)
- Enter (volume entered)
- Keep (volume kept)

You can use the fields found in the table to generate custom reports that report only on the specific needs of your site.

Usage

Use the following guidelines to produce a Custom Report:

- The PAGESIZE and LINESIZE used for any report ddname must remain the same for all reports written to that ddname.
- You must use different ddnames for PREACTION and POSTACTION reports.
- STYLE(DATA) reports must be written to a ddname not used by any other report.

The REPORT MVC_VTV report is identical to the REPORT VOLUME report, except:

- There is one detail line for each MVC/VTV combination.
- Volume fields are available on a detail line for both volumes.
- Volume fields can be prefixed with "VTV." or "MVC." to indicate which volume's field is being referred to. The default for non-MVC fields is VTV.
- Parameters LISTDD and LISTDSN can be qualified with "MVC." or "VTV." to indicate whether the volumes in the list are MVCs or VTVs. The default is "VTV."
- There is one additional parameter on REPORT MVC_VTV that is not on the other custom reports – BREAKZERO/NOBREAKZERO.
- Volume fields that are uniquely tied to VTVs will now be automatically qualified using VTV.fieldname, if a qualifier is not specified.
- Volume fields that are uniquely tied to MVCs or the library (LSM Cell Location, for example), will now be automatically qualified using MVC.fieldname, if a qualifier is not specified.

If LCM provides a qualifier, new informational message LCM1320I will be written to the parameter file listing to document the assumed qualifier.

Volume fields on the MVC_VTV report that remain unqualified will be populated using the VTV's volume information if possible. However, for MVCs that have no VTVs, the values for unqualified fields will come from the MVC instead.

FIGURE 6-41 on page 375 shows an example of a REPORT VOLUME statement that generates a report to ddname ERRANT of all volumes in the ACS in ERRANT status with volume serial, cell location, last date/time selected, scratch status and associated data set name. If no volumes are selected, the NORECMSG parameter generates the specified title only. FIGURE 6-42 shows an example of the report produced by the statement in FIGURE 6-41.

```

report          volume                               // Custom volume report
                DDname(ERRANT)                     // Output ddname
                title('Errant Cartridge Report')    // Report title
                norecmsg('No errant cartridges to report') // Text if no records match WHEN criteria

                When(                               // Start When condition
                (InLSM EQ True)                     //                               //
                and                                  //                               //
                (Errant EQ True)                    // HSC indicates volume is errant
                )                                    // End When Condition
                Column                               // Report columns
                (
                Volume,                             // Field name
                InitialLSMID,                       // Field name
                InitialLSMPanel,                    // Field name
                InitialLSMColumn,                   // Field name
                InitialLSMCell,                     // Field name
                SelectDate,                         // Field name
                SelectTime,                         // Field name
                Scratch,                             // Field name
                DataSetName                         // Field name
                )                                    // End of Column fields
                ;                                    // End of report statement

```

FIGURE 6-41 Example REPORT VOLUME Statement

2012-06-08 14:28:08		StorageTek Library Content Manager 7.2						PAGE 6	
Errant Cartridge Report									
Volume	InitialLSMID	InitialLSMPanel	InitialLSMColumn	InitialLSMCell	SelectDate	SelectTime	Scratch	DataSetName	
H06907	00:00	18	16	00:00:18:04:16	2012-08-29	12:03	Yes	SYSBACK.V0L00H.D AY	
H06908	00:00	18	14	00:00:18:04:14	2012-08-29	12:04	Yes	SYSBACK.V0L00H.D AY	
H06909	00:00	18	12	00:00:18:04:12	2012-08-29	12:04	Yes	SYSBACK.V0L00H.D AY	

FIGURE 6-42 Example Custom Volume Report

Custom LSM Reports

The most commonly used form of a condition compares one LSM *field* with a *value*. For example, to produce a report of LSMs that have fewer than 100 free cells, specify the following:

WHEN (PLANNEDFREECELLS LT 100)

In general, the AND keyword is used to reduce the set of LSMs to be included in the report and the OR keyword is used to expand the set of LSMs to be included in the report. For example, to specify that only LSMs that have fewer than 100 planned free cells and less than 100 planned scratch volumes are included in the report:

WHEN (PLANNEDFREECELLS LT 100 AND PLANNEDSCRATCH LT 100)

You can override the NOSUMMARY parameter with the SUMMARY subparameter of the CONTROL parameter (and vice versa). In the following example, no summary lines are printed except when the control break on the associated field occurs.

```
REPORT LSM
NOSUMMARY

.
.
CONTROL (
.
.
.
    ,
    field SUMMARY
    ,
.
.
.
);
```

[FIGURE 6-43 on page 377](#) and [FIGURE 6-44 on page 377](#) show example statements to produce the Custom LSM Report shown in [FIGURE 6-45 on page 378](#).

```

report      lsm                                     // This is an LSM report.

            title('LSM Report Summary')          // Title for report.

            control (

                heading                          // Heading at top of report
                ('Start of Summary Report',)

                footing                          // Footing at bottom of report
                ('End of Summary Report')

                summary                          // Text before final summary line
                (';Final Totals'),

                acsid                            // Page break by ACS ID
                page                            // with ACSID printed on top of page
                ('ACS &acsid.')

                footing                          // Footing on page break
                ('End of ACS &acsid.'),

                lsmgroup break                  // Control Break on LSM group
                heading                          // Heading on control break
                ('LSM Group &lsmgroup.',)

                footing                          // Footing on control break
                (';End of LSM Group &lsmgroup.',)

                summary                          // Text before final summary line
                (';Subtotal'),

                lsmid                           // Sort ascending on LSM ID

            )

```

FIGURE 6-43 Custom LSM Report Statements

```

            column (

                lsmid,                          // LSM ID
                lsmname,                        // LSM Name
                plannedfreecells                // Planned Free Cells
                heading                          // Column Heading
                ('Free', 'Cells'),

                plannedscratch                  // Total Planned Scratch Volumes
                heading                          // Column Heading
                ('Scratch'),

                plannednonscratch              // Total Planned NonScratch Volumes
                heading                          // Column Heading
                ('Non-', 'Scratch'),

                volumesignored,                // Volumes ignored
                plannedejects                  // Total Planned Ejects
                heading                          // Column Heading
                ('Ejects'),

                plannedmoveins                 // Total Planned Move Ins
                heading                          // Column Heading
                ('Move', 'Ins'),

                plannedmoveouts                // Total Planned Move Outs
                heading                          // Column Heading
                ('Move', 'Outs'),

            )
;

```

FIGURE 6-44 Custom LSM Report Statements (continued)

2012-05-14 06:37:21		StorageTek Library Content Manager 7.2						PAGE 1	
LCM Demand Run									
ACS 00		LSM Report Summary						LSM	
LSM ID	LSM Name	Free Cells	Scratch	Non-Scratch	Volumes Ignored	Ejects	Move Ins	Move Outs	
Start of Summary Report									
LSM Group Main									
00:00	Zero	0	198	30	0	70	0	16	
00:01	One	0	218	104	0	109	16	0	
Subtotal		0	416	134	0	171	16	16	
End of LSM Group Main									
LSM Group Storage									
00:02	Two	0	176	0	0	45	0	31	
00:03	Three	0	215	82	0	58	43	0	
00:04	Four	0	229	41	49	117	0	12	
Subtotal		0	700	123	49	220	43	43	
End of LSM Group Storage									
		0							
End of ACS 00									
Final Totals		0	1036	257	49	391	59	59	
End of Summary Report									

FIGURE 6-45 Custom LSM Report

LCM Operator Commands

This chapter describes the operator commands for LCM.

Using MVS Commands

Using the MVS MODIFY Command to Monitor and Control LCM Batch Jobs

You use the MVS MODIFY command to issue the LCM Display, Pause, REDIRECT, and Resume commands.

For example, to display the status of CAP 00:00 for jobname LCM, enter:

```
f LCM,display cap 00:00
```

Using the MVS STOP Command to Stop LCM

You can use the MVS STOP command to stop LCM. It will allow in-process operations to complete as follows:

- All volumes currently being ejected are placed in a CAP and must be removed before LCM stops.
- All volumes currently being moved are placed their destination cells before LCM will stop.
- All currently scheduled consolidations will complete.

For example, to stop jobname LCM:

```
p LCM
```

Note – If you enter the STOP command a second time, LCM terminates immediately, without waiting for scheduled actions to complete.

Using the MVS MODIFY Command to Monitor and Control LCM Agent

The LCM Agent also uses the MVS MODIFY command. For example, to display LCM Agent status, enter:

```
f lcmagent,display
```

To change the LCM Agent maximum concurrent client connections, enter:

```
f lcmagent,maxconn nn
```

where *nn* is the maximum concurrent client connections.

DISPLAY

The Display command displays LCM status, CAP ejects, volume moves, exports and VTV consolidations, migrations, and recalls.

Syntax

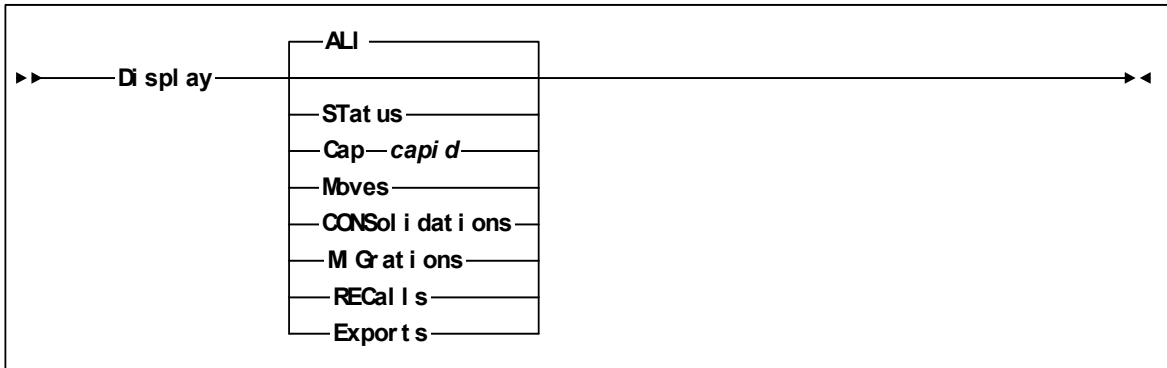

FIGURE 7-1 **Display** Command Syntax

Parameters

ALI

displays LCM status, CAP ejects, volume moves, exports and VTV consolidations, migrations, and recalls (the default).

Status

displays LCM status.

Cap

displays CAP ejects.

capid

a decimal CAP ID (00-99).

Moves

displays volume moves.

CONSolidations

displays VTV consolidations.

MIGrations

displays VTV migrations.

RECalls

displays VTV recalls.

Exports

displays VTV exports.

Usage

Use the Display command to display LCM status, CAP ejects, volume moves, and VTV consolidations, migrations, and recalls.

Examples

To display LCM status for jobname LCMJOB1:

F LCMJOB1, D ST

Output

FIGURE 7-2 shows the output from a F LCMJOB1, D ALL command.

```
18.48.08 JOB 6343 LCM4013| LCM command: DISPLAY
18.48.08 JOB 6343 LCM4007| Performing EJECTs and MOVEs.
18.48.08 JOB 6343 LCM4010| Moves are active for LCM.
18.48.08 JOB 6343 LCM4103| Moving B01560 to 00:00 from 00:02.
18.48.08 JOB 6343 LCM4103| Moving C03790 to 00:01 from 00:00.
18.48.08 JOB 6343 LCM4103| Moving C02760 to 00:03 from 00:02.
18.48.08 JOB 6343 LCM4011| Moves: Completed=43 Remaining=61.
18.48.08 JOB 6343 LCM4010| VTV Consolidations are active for LCM.
18.48.08 JOB 6343 LCM4051| Consolidating v00208 for group VVault1.
18.48.08 JOB 6343 LCM4051| Consolidating v03937 for group VVault2.
18.48.08 JOB 6343 LCM4051| Consolidating v02873 for group VVault3.
18.48.08 JOB 6343 LCM4049| VTV Consolidations: Completed=211 Remaining=38.
18.48.08 JOB 6343 LCM4008| CAP 00:00:00 in use by LCM. Location Vault
18.48.08 JOB 6343 LCM4009| CAP 00:00:00 Ejects: Completed=0 Remaining=65.
18.48.08 JOB 6343 LCM4008| CAP 00:00:01 in use by LCM. Location Vault
18.48.08 JOB 6343 LCM4009| CAP 00:00:01 Ejects: Completed=0 Remaining=48.
18.48.08 JOB 6343 LCM4008| CAP 01:00:00 not in use by LCM.
```

FIGURE 7-2 Sample Output from a Display Command

PAUSE

The **Pause** command suspends CAP ejects, volume moves, exports and VTV consolidations, migrations, and recalls.

Syntax

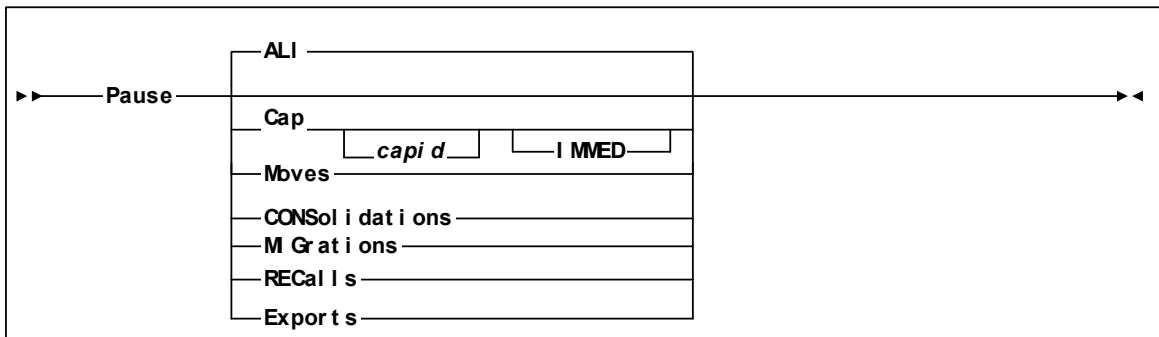

FIGURE 7-3 Pause Command Syntax

Parameters

ALI

suspends CAP ejects, volume moves, exports and VTV consolidations, migrations, and recalls (the default).

Cap

suspends CAP ejects after scheduled ejects complete.

capid

a decimal CAP ID (00-99). If not specified, LCM suspends activity for all CAPs.

IMMED

immediately suspends CAP ejects.

Moves

suspends volume moves after in-process moves complete.

CONSolidations

suspends VTV consolidations.

MIGrations

suspends VTV migrations.

RECal ls

suspends VTV recalls.

Exports

suspends VTV exports.

Usage

Use the **Pause** command to suspend CAP ejects, volume moves, and VTV consolidations, migrations, and recalls. Use the **Resume** command to resume suspended activities; for more information, see “RESUME” on page 354.

Note –

- If you enter a **P CONS** command, LCM issues message LCM4120E because LCM cannot interrupt active consolidation requests and must wait for them to complete before it can stop or pause as requested. LCM also issues messages LCM4121E and LCM4122E that tell how to interrupt scheduled consolidation requests, then continues waiting for the consolidations to complete.
 - If volume moves are tying up the robot and slowing down ejects, suspend moves until ejects occur more quickly.
-

Examples

To immediately suspend CAP ejects for jobname LCMJOB1:
F LCMJOB1, P C IMMED

Output

[FIGURE 7-4](#) shows the output from a **F LCMJOB1, P M** command.

```
18.50.11 JOB 6343 LCM4010I Moves by LCM are paused.  
18.50.11 JOB 6343 LCM4011I Moves: Completed=0 Remaining=61.
```

FIGURE 7-4 Sample Output from a **Pause** Command

REDIRECT

The REDIRECT command redirects ejects from a CAP in one LSM to a CAP in another LSM.

Syntax

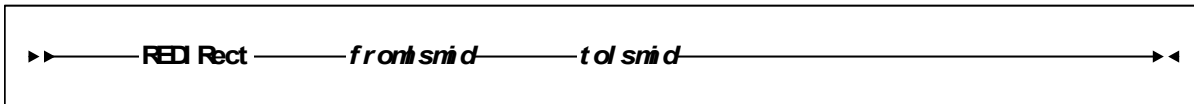

FIGURE 7-5 REDIRECT Command Syntax

Parameters

fromlsmid

redirects CAP ejects from this LSM.

*to**lsmid*

redirects CAP ejects to this LSM.

Usage

Use the REDIRECT command to redirect ejects from a CAP in one LSM to a CAP in another LSM (for example, if the first LSM or its CAP go offline).

Examples

To redirect ejects from a CAP in LSM 00:01 to a CAP in LSM 00:00:
F LCMJOB1, REDIR 00:01 00:00

Output

FIGURE 7-6 shows the output from a F LCMJOB1, REDIR command.

```
18.50.11 JOB 6344 LCM4032I Ejects planned for CAP 00:01  
have been redirected to CAP 00:00.
```

FIGURE 7-6 Sample Output from a REDIR Command

RESUME

The Resume command resumes CAP ejects, volume moves, VTV exports, migrations, recalls, and consolidations.

Syntax

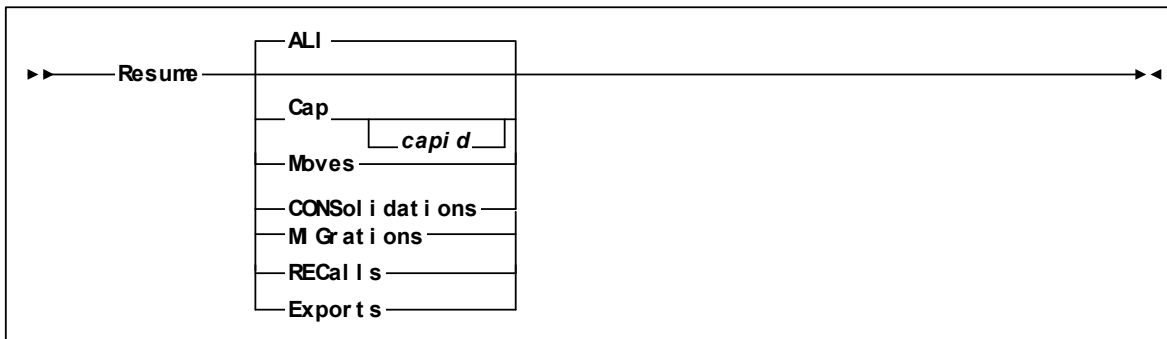

FIGURE 7-7 Resume Command Syntax

Parameters

ALI

resumes CAP ejects, volume moves, and VTV consolidations (the default).

Cap

resumes CAP ejects.

capid

a decimal CAP ID (00-99). If not specified, LCM resumes activity for all CAPs.

Moves

resumes volume moves.

CONSolidations

resumes VTV consolidations.

MIGrations

resumes VTV migrations.

RECalls

resumes VTV recalls.

Exports

resumes VTV exports.

Usage

Use the **Resume** command to resume CAP ejects, volume moves, and VTV consolidations, migrations, and recalls. **Resume** also starts any specified activity that has not already started.

Examples

To resume CAP ejects for jobname LCMJOB1:
F LCMJOB1, R C

LCM SAMPLIB Members

The LCM SAMPLIB member LCMINDEX contains the members described in [TABLE A-1](#).

TABLE A-1 LCM SAMPLIB Members

Member	Description
LCMAGENT	Sample LCM Agent started task procedure.
LCMAPFXX	Sample LCM authorized library list entry.
LCMCGI	Sample CGI script for TMS OPEN interface.
LCMCHGS	Cumulative documentation changes for the release as PTFs are applied
LCMCODES	Sample LCM Agent access code file.
LCMEXEC	Sample JCL procedure for use with jobs submitted by the LCM Explorer, as well as other LCM jobs submitted by an installation. LCMEXEC pre-defines certain items that are common to all LCM runs at the installation. For example, if LCM is installed in a library that is not included in the linklist or LPA list, LCMEXEC should have a STEPLIB pointing to the production LCM load library. DD statements that are dynamically allocated by most LCM jobs or are different from one LCM job to the next should not be in LCMEXEC .
LCMKST	Documents the key values for each extended field. LCMKST contains a list of equates for all extended fields. All extended fields will have a key greater than 0 associated with them. For more information, see "Guidelines for Producing TMCi Records" in Appendix C. Data Areas of <i>LCM User's Guide</i> .
LCMMTHF	Macro for defining the layout of a method file record. For more information, see "METHODFILE Record" in Appendix C. Data Areas of <i>LCM User's Guide</i> .
LCMRUN	Sample JCL to run LCM.
LCMTIDR	Sample TMS Interface Definition Response xml document.
LCMTMCI	Macro for defining the layout of an LCM TMC information record.
LCMTTIR	Sample TMS Tape Information Response XML document used with the TMS OPEN interface.
LCMUX01P	Macro for defining the parameter list used by the LCM TMS CUSTOM interface. For more information, see "TMS CUSTOM Interface Module Parameters" in Chapter 3 of the <i>User's Guide</i> .
LCMUX01S	Sample assembler program for use with the LCM TMS CUSTOM interface.
LCMVAUTM	LCM parameter file for IVP with Automeia.
LCMVCA1	LCM parameter file for IVP with CA-1.
LCMVCOMM	LCM parameter file for IVP with common-format TMS extract files.

TABLE A-1 LCM SAMPLIB Members

LCMVCONT	LCM parameter file for IVP with Control-T
LCMVCUST	LCM parameter file for IVP with LCM custom tape management system interfaces (a tape management system vendor supplied user exit is required).
LCMVNTMS	LCM parameter file for IVP without a TMS.
LCMVRMM	LCM parameter file for IVP with DFSMSrmm.
LCMVTLMS	LCM parameter file for IVP with CA-TLMS.
LCMXDMD	LCM parameter file for demand (or shift) run.
LCMXDVLD	LCM parameter file for vaulting run with special data sets.
LCMXDVLS	LCM parameter file for vaulting run with multiple subpools.
LCMXDVL	LCM parameter file for daily vaulting run
LCMXRAL1	LCM parameter file for report of all physical volumes in an ACS with cell location
LCMXRAC1	LCM parameter file for a post action report.
LCMXREJ1	LCM parameter file for an eject report that includes data set name.
LCMXREJ2	LCM parameter file for a report of volumes ejected for need by data set name.
LCMXREJM	LCM parameter file for report of all planned moves and ejects with final status of action.
LCMXREN1	LCM parameter file for a report of volumes on a Pull List that were not already in an LSM.
LCMXRERV	LCM parameter file for report of ERRANT volumes with key volume metadata.
LCMXRMT1	LCM parameter file for a summary report with counts of several methods.
LCMXRMVC	LCM parameter file for report of all MVCs with volume metadata.
LCMXRSM1	LCM parameter file for an LSM summary report.
LCMXRSR1	LCM parameter file for a non-LSM scratch list report.
LCMXRVR1	LCM parameter file for a report of all volumes with HSC and TMS information.
LCMXSYNC	LCM parameter file for scratch synchronization
LCMXT_{xxx}	Template version of report LCMXR _{xxx}
LCMXTINV	Template to produce inventory report with volume metadata including dataset name.
LCMXTMUL	REPORT MULTIPLE template
LCMXTPHY	REPORT PHYSICAL template
LCMXTVIR	REPORT VIRTUAL template

A Sample LCM Workflow

For both Nearline and VSM resources, you can obviously do just about any management task you want using LCM. In this appendix, we'll show a sample workflow for a simple 2-LSM ACS using a combination of LCM parameter file examples and parameter file samples provided in the LCM SAMPLIB, which are described in [TABLE A-1 on page 389](#). In most cases, you'll note that there's usually a TMS statement in the parameter file because your TMS provides a variety of useful information that LCM can use to do management tasks.

TABLE B-1 A Sample LCM Workflow

Task	Notes
Run a volume report that shows HSC and TMS information for all volumes managed by LCM.	Use SAMPLIB member LCMXRVR1.
Do scratch synchronization.	See "Scratch Synchronization Parameter File" on page 392 for an example or use SAMPLIB member LCMXSYNC. Rerun the volume report to see the results.
Run a report to see the planned activity for the site.	See "Basic "Manage" Parameter File" on page 392 . Create a file like this for your site, modify the LSM report in member LCMXRSM1as needed and add the report to the Basic Manage File to get a report of the planned real and virtual activity.
The planned activity doesn't do what I want, run a stock management file to adjust resources...	...as described in "Manage File to Adjust Resources" on page 393 .
I've just run the TMS vaulting procedure, and I want LCM to facilitate the "eject to vault" operation...	...as described in "Parameter File for Vaulting Run" on page 394 . You might also want to review the eject report with the volumes to be ejected. An operator report will have any details for the operator.

Scratch Synchronization Parameter File

FIGURE B-1 shows a parameter file to synchronize the HSC CDS scratch status of real and virtual volumes with the scratch status in the TMS. You typically run this job, therefore, after a TMS update.

```
options
    title ('Scratch Synchronization Parameter File')
    sync
    syncvtv;
tms ca1
    name('CA1SITE1')
    tmcdsn(ca1.tmc)
    agent(123.123.123.123 3002);
manage physical acsid(00);
manage virtual;
```

FIGURE B-1 Scratch Synchronization Parameter File

Basic “Manage” Parameter File

FIGURE B-2 shows a basic manage parameter file. Because I have only a two-LSM ACS, I can usually manage it at the ACS level. The MANAGE PHYSICAL statement, therefore, is simple and at the ACS level: all I want to do is globally identify the physical resources I’m managing so I can get a report for a sanity check of the planned actions.

```
options
    title ('Basic Manage Parameter File')
    check
        external(neverreject uncond)
        ejcap (00:00 00:01);
tms ca1
    name('CA1SITE1')
    tmcdsn(ca1.tmc)
    agent(123.123.123.123 3002);
manage physical acsid(00)
manage virtual;
// Modified LSM report from LCMXRSM1 goes here //
```

FIGURE B-2 Basic “Manage” Parameter File

Manage File to Adjust Resources

FIGURE B-3 shows a manage file to adjust resources. The report I ran in “Basic “Manage” Parameter File” on page 392 showed that I had less than optimal balances of scratch volumes, cleaning cartridges, and free cells across the two LSMs in my ACS. To clean things up, I run the stock “manage to rebalance” file shown in FIGURE B-3.

```
options
  title ('Manage File to Adjust Resources')
  external(neverreject uncond)
  ejcap (00:00 00:01);
tms ca1
  name('CA1SITE1')
  tmcdsn(ca1.tmc)
  agent(123.123.123.123 3002);
manage physical acsid(00)
  balscr(10)
  balcln (2)
  balfree(10);
manage virtual;
```

FIGURE B-3 Manage File to Adjust Resources

Parameter File for Vaulting Run

FIGURE B-4 shows a parameter file to physically eject volumes from the ACS per the policies specified in the TMS vaulting run.

```
options
    title ('Parameter File for Vaulting Run')
        external(neverreject uncond)
        ejcap (00:00 00:01);
tms ca1
    name('CA1SITE1')
    tmcdsn(ca1.tmc)
    agent(123.123.123.123 3002);
manage physical acsid(00);
method name(vault) eject(yes);
location code(vlt1) name(Vault1) method(vault) slots;
location code(arch) name(Archive) method(vault) slots;
location code(' ' VMS) name(Local) noslots;
```

FIGURE B-4 Parameter File for Vaulting Run

In FIGURE B-4, note the following:

- I defined a method (vault) and said “any volumes with this method, eject them unconditionally.”
- I created 3 LOCATION statements, which defined the following CA1 VMS vault names to LCM:
- Statements for VMS user-defined vaults vlt1 and arch (in CA1, vault names are considered location codes), which I’ve named Vault1 and Archive to LCM. When VMS schedules the volume for vaulting, these vault codes are applied to the volume, and method vault ejects the volumes by TMS slot number.
- The remaining LOCATION statement says “For the main library (denoted by the blank) and the VMS-defined vault VMS, don’t do anything.”

ELS Alphabetic Volsers

ELS supports alphabetic volser ranges for all commands and utilities. The rules for alphabetic volser ranges are as follows:

1. An alphabetic volser range consists of a pair of volsers (start volser and end volser) containing an incrementing alphabetic portion of 1 to 6 characters. For example; 00000A-00000Z, ABCAAA-ABCZZZ, 9AA000-9CC000, A00A00-A00M00.
 - a. A volser is composed of sequence of one to six numerics, (upper case) alphabetic or national characters (#, @ and the primary national currency symbol).
 - b. A volser of less than six characters is left justified and blank padded. Each volser element in a range must have the same number of characters specified. For example, if the first volser element is 4 characters, the second must be exactly 4 characters.
2. The start and end volsers forming a volser range consists of the following sub-elements: an optional prefix, an incremental portion, and an optional suffix.

[TABLE C-4 on page 397](#) shows examples of alphabetic volser ranges.

 - a. The optional prefix consists of identical leading characters (if any) in the start and end volsers.
 - b. The incremental portion starts at the first non-identical leading character in the start and end volsers forming a range. The incremental portion is either:
 - All numeric (contains characters 0 through 9 only).
 - All alphabetic (contains character A through Z only).The incremental portion of a volser range, therefore, terminates where a change of character type (numeric -> alphabetic or alphabetic -> numeric) is detected.

The incremental type is derived from the character type of the first character in the incremental part (numeric/alphabetic). [TABLE C-1](#) shows example incremental ranges.

TABLE C-1 Example Incremental Ranges

volser Range	Incremental Portion	Data Type
00000A-00000Z	A-Z	Character
ABCAAA-ABCZZZ	AAA-ZZZ	Character
9AAZ00-9CCZ00	AAZ-CCZ	Character
A00B00-A99B00	00-99	Numeric
A00A00-A00M00	A-M	Character
A00B00-A00B99	00-99	Numeric

Note the following rules for incremental ranges:

- The expansion of an alphabetic incremental part is derived from a collating sequence of A-Z (it will not include the national character set).
 - The data types of the incremental portions in the start and end volsers must be identical.
 - The position of the incremental portion of the start volser must match that of the end volser.
 - The length of the incremental portion of the start and end volsers must be identical.
 - The incremental portion of the end volser must be greater than or equal to the start volser.
- c. The optional suffix consists of the trailing characters from the end of the incremental portion onwards. [TABLE C-2](#) shows an example range suffix.

TABLE C-2 Example Range Suffix

Volser Range	Incremental Portion	Suffix
A00B00-A00B99	00-99	none
A00B@0-A00D@0	B-D	@0
9AAZ00-9CCZ00	AAZ-CCZ	00 (not Z00)
900A@A-950A@A	900-950	A@A
ABCAAA-ABCZZZ	AAA-ZZZ	none

For a range to be valid the suffix of the start and end volsers forming the range must be identical.

3. The number of volumes generated from an alphabetic volser range is dependent on the number of elements in the incremental portion of the volser elements. For an A to Z range in each character position, the number of volumes can be calculated by 26 to the power of the number of positions that are being incremented as shown in [TABLE C-3](#).

TABLE C-3 Size of Alphabetic Volser Ranges

Range	Calculation	Number of Volumes
A-Z	26 ¹	26
AA-ZZ	26 ²	676
AAA-ZZZ	26 ³	17,576
AAAA-ZZZZ	26 ⁴	456,976

4. Per [TABLE C-3](#), it is possible to define 26⁴ VTVs in a single range. **Note, however, that** the more VTVs you define, the bigger your CDS has to be.

Alphabetic Volser Examples

[TABLE C-4](#) and [TABLE C-5](#) on page 399 describe valid and invalid alphabetic ranges.

TABLE C-4 Valid Alphabetic Ranges

Range	Subcomponents			Number of VTVs
	Prefix	Incremental Portion	Suffix	
AAA000-AAZ000	AA	A-Z	000	26
A00A00-A00A99	A00A	00-99		100
0AAAA0-0ZZZZ0	0	AAAA-ZZZZ	0	456,976
A00A00-A99A00	A	00-99	A00	100
99AA##-99ZZ##	99	AA-ZZ	##	676
A9A000-A9Z000	A9	A-Z	000	26
#####-#####	#####			1
AA00##-ZZ00##		AA-ZZ	00##	676
AA00##-AA99##	AA	00-99	##	100
PROD00-PROD99	PROD	00-99		100
PROD00-PROZ00	PRO	D-Z	00	23
A4Z#@0-A9Z#@0	A	4-9	Z#@0	6
A4Z#@0-Z4Z#@0		A-Z	4Z#@0	26
A4Z#@0-A4Z#@6	A4Z#@	0-6		7
AAAAAA-AAACCC	AAA	AAA-CCC		1407

TABLE C-4 Valid Alphabetic Ranges

A3BZZ9-A3CDE9	A3	BZZ-CDE	9	84
999AM8-999CM8	999	AM-CM	8	53
111AAA-111ZZZ	111	AAA-ZZZ		17576

TABLE C-5 Invalid Alphabetic Ranges

Range	Subcomponents			Number of VTVs	Comments
	Prefix	Incremental Portion	Suffix		
0AAAAA-0BAAAA	0	AAAAA-BAAAA		456,977	Greater than 456,976 VTVs
A9A000-A9Z999					Cannot mix incremental portions
#####-#####@					National characters cannot increment
AA00##-ZZ99##					Invalid range
CCNNZZ-CDNZAA		CCNNZZ-CDNZAA		464,414	Greater than 456,976 VTVs
A4Z#@0-A9Z#@9					Invalid range

Data Areas

This appendix describes the following LCM data areas:

- [“TMCi Record” on page 402](#)
- [“METHODFILE Record” on page 409](#)

TMCI Record

The TMCI is a variable length record that the TMS Common and Custom interfaces use to provide LCM with TMS information about a single volume as described in the following sections:

- [“Guidelines for Producing TMCI Records” on page 403](#)
- [“TMCI Record Layout” on page 404](#)
- [“TMCI Record Date Formats” on page 406](#)
- [“TMCI Record Time Formats” on page 407](#)
- [“TMCI Record Boolean Formats” on page 407](#)
- [“TMCI_EXPIREDATE Special Formats” on page 4089](#)

Guidelines for Producing TMCI Records

Use the following guidelines to produce TMCI records for the TMS CUSTOM and COMMON interfaces:

- TMS COMMON files must be variable length sequential data sets, where each logical record in the TMS COMMON data set is one TMCI record.
- TMS CUSTOM interface modules must prefix TMCI records with a record descriptor word. The record descriptor word consists of a signed halfword length value followed by a halfword of zeros.
- To initialize a TMCI record before populating its fields for a specific volume, StorageTek recommends that you first clear the entire record with binary zeros and then set character fields to blanks.
- The minimum requirement is to produce TMCI records long enough to contain all fields up to and including the TMCI_REFDATE field. Shorter TMCI records will cause unpredictable results at best and may cause catastrophic errors.

Some fields in the TMCI record are optional, but you should supply as much information as possible for each volume, including “residual data” for scratch volumes and expired volumes. If possible, produce full length TMCI records with values for “information not provided” for fields with no information for the data types described in [TABLE D-1](#).

TABLE D-1 TMCI Values “Information Not Provided”

Type	Value for “Information Not Provided”
BIN	Binary zeros
CHAR	Blanks
DATE	The date format (first byte) must be binary zeros. Remaining bytes of DATE fields are irrelevant, but it is often easiest to clear the entire field.

- For nonscratch volumes, LCM assumes that the value of TMCI_DSNAME contains a valid (not missing) data set name. If nonscratch volumes in a specific TMS can have data set names that are blank or otherwise invalid, you must modify the TMCI records for these volumes to supply a valid data set name. Otherwise, you cannot pass TCMCI records for these volumes to LCM.
- If you specify the TMS statement EJBAD option, the TCMCI records must pass information about defective volumes to LCM.
- Note that LCM 5.0.0 and above provides extended fields in the TMCI, which have the prefix TMCI_EFV. SAMPLIB member LCMKST lists the equates for these extended fields; for more information, see [“LCM SAMPLIB Members” on page 389](#).

TMCI Record Layout

TABLE D-2 describes the TMCI record layout. SAMPLIB member LCMTMCI is an assembler mapping macro for the TMCI.

TABLE D-2 TMCI Record Layout

Field	Offset	Column	Type	Len	Description
TMCI_START	0 (00)		DSECT		Start of TMCI record.
TMCI_LENGTH	0 (00) 2 (02)		BIN BIN	2	Length of TMCI record, including this field. Reserved. Should be binary zeroes.
TMCI_DATA	4 (04)			2	This label indicates the beginning of the data portion of the TMCI record.
TMCI_VOLSER	4 (04)	1	CHAR	6	Volser for the volume for which information is being provided.
TMCI_SCRATCH	10 (0A)	7	CHAR	1	Scratch indicator. If C'Y', this volume is scratch; otherwise, it is not.
TMCI_SITE	11 (0B)	8	CHAR	8	Out-of-area code, or location code.
TMCI_SLOT	19 (13)	16	CHAR	8	Slot number assigned to this volume.
TMCI_REFDATE	27 (1B)	24	DATE	13	Date volume was last referenced. Note: Refer to "TMCI Record Date Formats" on page 377 for information on the supported date formats.
TMCI_CREATEDATE	40 (28)	37	DATE	13	Creation date of data set on volume. Note: Refer to "TMCI Record Date Formats" on page 377 for information on the supported date formats.
TMCI_DSNAME	53 (35)	50	CHAR	44	Data set name of controlling data set for volume.
TMCI_USE	97 (61)	94	BIN	4	Volume use count. Zero, or a positive fullword integer.
TMCI_VOLSEQ	101 (65)	98	BIN	4	Volume sequence number. Must be a signed fullword between 0 and 32767.
TMCI_EXTERNAL	105 (69)	102	CHAR	1	Externally managed indicator. If C'Y', the volume is managed by an external data manager.
TMCI_TAPE_TYPE	106 (6A)	103	CHAR	1	Type of media. 9-track (C'0') or cartridge (C'1').
TMCI_CREATETIME	107 (6B)	104	CHAR	5	Creation time in the format 'HH:MM', based on a 24 hour clock.
TMCI_CYCLEDATE	112 (70)	109	DATE	13	Estimated expiration date of volume. LCM will use this date to implement the CYCLESOON option. Note: Refer to "TMCI Record Date Formats" on page 406 for information on the supported date formats.
TMCI_FIRSTVOL	125 (7D)	122	CHAR	6	Volser of the first volume in this volume's volume-set.

TABLE D-2 TMCI Record Layout

Field	Offset	Column	Type	Len	Description
TMCI_BAD	131 (83)	128	CHAR	1	Bad (or damaged) volume indicator. If C'Y', the volume has been marked as having defective media by the TMS. If the EJBAD option has been coded in the LCM parameter file, volumes that reside in a managed LSM and have a C'Y' in this field will be unconditionally ejected.
TMCI_EXPIRED	132 (84)	129	CHAR	1	Expired volume indicator. If C'Y', the volume has been marked as expired in the TMS. Expired volumes are automatically classified as CYCLESOON volumes by LCM.
TMCI_JOBNAME	133 (85)	130	CHAR	8	Creating jobname.
TMCI_STEPNAME	141 (8D)	138	CHAR	8	Creating stepname.
TMCI_EXPIREDATE	149 (95)	146	DATE	13	Expiration date of volume (unchanged). A special date format of x'99' (p'153') can be used only by this field to print decoded keywords such as 'Catalog' or 'Permanent' on the REPORT VOLUME. Note: Refer to "TMCI Record Date Formats" on page 406 and "TMCI_EXPIREDATE Special Formats" on page 408 for information on the supported date formats.
TMCI_MGMTCLAS	170 (A2)	159	CHAR	8	SMS Management Class. Used only in LCM 2.1 and above.
TMCI_LOCDATE	170 (AA)	167	DATE	13	Specifies the date the volume was moved to a tape storage location.
TMCI_DELETED	183 (B7)	180	CHAR	1	If marked 'Y', deleted from the TMS.
TMCI_EFV_OFFSET	184 (B8)	181	BIN	2	Offset: (TMCI_EFV_FIRST to TMCI_DATA_START)
TMCI_EFV_COUNT	186 (BA)	183	BIN	2	Number of extended fields.
TMCI_EFV_FIRST	188 (BC)	185	BIN	2	Start of first field value, mapped by TMCI_EFV_FIELD (see below). Do not reference this tag directly except to calculate TMCI_EFV_OFFSET.
TMCI_EFV_FIELD					Extended field.
TMCI_EFV_ID			BIN	2	Extended field key ID (greater than 0).
TMCI_EFV_VALUE_SIZE			BIN	2	Size of field value.
TMCI_EFV_VALUE			BIN	variable	Field value.
TMCI_MAXIMUM_LENGTH			EQU	4096	Equate symbol equal to the length of a fully populated TMCI record, including the record descriptor word and extended fields.

TMCI Record Date Formats

TABLE D-3 describes the date formats that the TMCI supports. Date field begins with a one byte date format value, followed by a date value up to twelve (12) bytes in length. The TMCI record DSECT provides equate symbols (EQU) for each supported date format value.

TABLE D-3 TMCI Record Date Formats

Type	Equate Symbol	Date Format	Example
0	TMCI_DATE_NOT_PROVIDED	Date not provided	AL1(0)
2	TMCI_JULIAN	Full Julian	AL1(2),C'1989359'
3	TMCI_JULIAN_DECIMAL	Full Julian	with decimal AL1(3),C'1989.359'
4	TMCI_PACKED_JULIAN	4-byte packed decimal Julian	AL1(4),PL4'1989359'
6	TMCI_SHORT_JULIAN	Short Julian (1900's assumed)	AL1(6),C'89359'
7	TMCI_SHORT_JULIAN_DECIMAL	Short Julian with decimal	AL1(7),C'89.359'
11	TMCI_SHORT_GREGORIAN	Short Gregorian	AL1(11),C'12/25/89'
12	TMCI_GREGORIAN	Gregorian	AL1(12),C'12/25/1989'
13	TMCI_SORTABLE	Sortable	AL1(13),C'1989-12-25'
14	TMCI_SHORT_SORTABLE	Short sortable	AL1(14),C'89-12-25'
31	TMCI_SHORT_NORMAL	Short REXX normal	AL1(31),C'25 Dec 89'
32	TMCI_NORMAL	REXX normal	AL1(32),C'25 Dec 1989'
33	TMCI_SASDATE7	SAS DATE7.	AL1(33),C'25DEC89'
34	TMCI_SAS_DATE9	SAS DATE9.	AL1(34),C'25DEC1989'
153	TMCI_SPECIAL	Special 4-byte packed decimal	AL1(153),PL4'9999999'

TMCI Record Time Formats

TABLE D-4 describes the time formats that the TMCI supports. Time fields begin with a one byte date format value, followed by a time value up to eight (8) bytes in length. The TMCI record DSECT provides equate symbols (EQU) for each supported time format.

TABLE D-4 TMCI Time Formats

Type	Equate Symbol	Time Format	Example
0	TMCI_TIME_NOT_PROVIDED	Time not provided.	AL1(0)
2	TMCI_HUNDREDTHS	4-byte binary integer equal to the number of .01-second units since midnight	AL1(2),F'3115074
3	TMCI_HHMM	Time in hours and minutes.	AL1(3),C'13:03'
4	TMCI_HHMMSS	Time in hours, minutes, and seconds.	AL1(5),C'13:03:40.40'
6	TMCI_CIVILIAN	Time in hours, minutes, and seconds followed by an AM/PM indicator.	AL1(6),C' 1:03:40 AM'
7	TMCI_TODCLOCK	System/370 time-of-day clock format.	AL1(7),XL8'TOD Value'
17	TMCI_SECONDS_SINCE_1970	4-byte binary integer equal to the number of seconds since Jan 1, 1970, 00:00:00.0.	AL1(17),F'3532715'

TMCI Record Boolean Formats

TABLE D-5 describes the Boolean formats that the TMCI supports. Boolean values are coded as a single byte; use "Y" for true and "N" for false.

TABLE D-5 TMCI Record Boolean Formats

Equate Symbol	Boolean Value	Example
TMCI_TRUE	BOOLEAN value for TRUE.	C'Y'
TMCI_FALSE	BOOLEAN value for FALSE.	C'N'

TMCI_EXPIREDATE Special Formats

TABLE D-6 describes the TMCI format TMCI_SPECIAL. The first column contains the packed decimal number in the TMCI. Any lower case alphabetic 'nnn' indicates any decimal number must be substituted. The second column describes the decoded keywords that will print in a REPORT VOLUME for the EXPIREDATE field. If you want the decoded keyword to print, you must provide the exact 4 byte packed value described in the table.

TABLE D-6 TMCI_EXPIREDATE Decoded Values

4 Byte Packed Decimal Number	Decoded Keyword
9988nnn	User/nnn
9989nnn	Stats/nnn
9990000	Catalog
9990nnn	Catlg/nnn
9991nnn	Msg/nnn
9992nnn	Age/nnn
9998000	Foreign
9998nnn	Ldate/nnn
9999nnn	Cycle/nnn
9999999	Permanent

METHODFILE Record

TABLE D-7, each record in the method file specified by ddname LCMMTHIN specifies a volser and the management method for that volume.

TABLE D-7 Method File Record Format Description

Starting Column	Ending Column	Field Description
1	6	Volser (left-justified and padded with trailing blanks if necessary)
7	16	Management method for the volume (left-justified and padded with trailing blanks if necessary)
17	17	Specifies how the management method applies to the volume: Blank or D - specifies that the method applies only if no other statement or option specifies a method for the volume. This method overrides methods specified by the OPTIONS statement EXTERNAL and HSCONLY parameters unless those parameters specify the UNCOND keyword. U - specifies that the method always applies, and overrides any other statement or option that covers the same volume. The method overrides methods specified by the OPTIONS statement EXTERNAL and HSCONLY parameters even if those parameters specify the UNCOND keyword.

Note: All other columns must contain blank characters.

Elements Tags for Dynamically Added Fields

TABLE E-1 describes the element tags that can be used when defining dynamic volume fields within the TMS Interface Definition Response Document.

TABLE E-1 Element Tags for Dynamic Volume Fields

Data Tag	Occurs In	Used By	Definition	Multiple	Content
<fielddefinitions>	<tmsinterfacedefinitionresponse>		Contains <field> elements	No	Element
<field name="">	<fielddefinitions>	E,B	Name of the field being defined. Field name can be a maximum of 25 characters in length. This does not include the TMS name and delimiter applied during creation	Yes	Element
<headings>	<field>		Contains <h> elements.	No	Element
<h>	<headings>	E,B	Contains default header lines of the field.	Yes	Mixed
<datatype>	<field>	E,B	Type of data that is used in this field. Acceptable values are: INT, CHAR, BOOL, DATE, TIME	No	Mixed
<defaultsummarytype>	<field>	E,B	Acceptable values are: NONE (for char, date, time), SUM or AVG (for int), TRUE (for bool)	No	Mixed
<defaultoutputsize>	<field>	E,B	Length of the output field	No	Mixed

TABLE E-1 Element Tags for Dynamic Volume Fields

<xmlinputsize>	<field>	B	Input size for field in TMS Tape Information volume record. This is only allowed for CHAR datatypes	No	Mixed
<collate>	<field>	B	Collating sequence for character fields. Acceptable values are: NORMAL, ALTERNATE	No	Mixed
<aliases>	<field>		Contains <alias> elements.	No	
<alias>	<aliases>	B	Other valid names for a field. Ex: serial has aliases of ser, volser, volume, vol	Yes	Mixed
<description>	<field>	E	Description of the field	No	Mixed
<possiblevalues>	<field>	E	Contains <pv> and <pd> elements.	No	Element
<pv>	<possiblevalues>	E	Possible value for a field. Acceptable values depend on the field. Example, field Classification has possible values of SCRATCH, NONSCRATCH, BADSCRATCH, EXPIRED, CLEAN,	Yes	Mixed
<pd>	<possiblevalues>	E	Description of a possible value. A description element <pd> is always paired to a value <pv> element.	Yes	Mixed

Field Descriptions

Data Tag

Lists the exact name of the XML element, plus any attributes that can be included within the tag.

Occurs In

The parent data tag that the specified data tag resides under.

Used By

E=Explorer, B=Batch job

Definition

A brief description of the contents of the data tag.

Multiple

Specifies whether there can be more than one data tag of the same name specified.

Content

Specifies if the data tag contains Parsed Character Data (Mixed) or other data tags(Element).

Using the Performance Zone

The introduction of the StorageTek SL8500 library, a new architecture was implemented that created the opportunity to take of differences in mount/dismount performance within this architecture. The subsequent introduction of the StorageTek SL3000 library also provided this same opportunity. From the day of general availability of the SL8500, LCM has provided a mechanism to take advantage of this opportunity as a part of the user's overall content management plan. The Performance Zone (PZ) in both libraries is a defined set of panels that have the performance characteristics that have that result decreased mount/dismount times. Volumes are assigned to the PZ via the `METHOD` statement but to maximize the effect, care should be taken to clearly identify a unique set of volumes that benefit most from their placement in the PZ. Generally this would be a set of volumes that are likely to be mounted numerous times in a fairly short period of time and that the underlying application can truly benefit from the better mount/dismount performance. For the latter, the main consideration is the total mount time, with short overall mounted times benefiting the most. Due to individual characteristics of the two libraries, the management is slightly different.

SL8500 Performance Zone

For the SL8500, the PZ is defined as all cells within Panels 04 to 15 in each rail or LSM. LCM will move volumes on the LSM identified as PZ volumes via the `METHOD` statement to cells within the designated PZ area. Once all available cells are filled with PZ volumes, LCM will move non-PZ volumes from this area to make room for a PZ volume until the PZ is totally full of PZ volumes. At that point, any remaining PZ volumes outside the PZ area may be moved to the nearest available cell location to the PZ, starting with Panel 16, if such volume needs to be moved for other management requirements.

The result of these movements is that the LSM is effectively partitioned into PZ volumes and non-PZ volumes. In many cases, this partitioning is taken one step further by moving inactive volumes from the LSM to another location. The resulting effect is that currently active volumes may be placed in the PZ, recently active volumes on the rail/LSM outside the PZ, and inactive volumes in another LSM. History has shown that the most recently mounted volumes have the highest probability of being mounted again, thus basing the management of an applications volumes on last referenced criteria can result in this three partition methodology being quite effective. In many of the applications that benefit from the use of the PZ, it has been found that as many as 50% of the volumes used are inactive at any point in time and only 15-20% of the volumes are currently active.

SL3000 Performance Zone

For the SL3000, the PZ is defined as all cells within Panels 10 to 13, the panels within the Base Drive Module (BDM) and the Expansion Drive Module (EDM). As with the SL8500, PZ volumes are moved in to the PZ, displacing non-PZ volumes as necessary. Once the PZ is full of PZ volumes, remaining PZ volumes are moved to panels closer to the PZ working both from the right and left sides of the PZ if movement of these volumes is otherwise required.

As the SL3000 is a single LSM and no movement to other LSMs is possible, the logical partition between PZ and non-PZ volumes is the limit with the SL3000...current active versus not currently active. The other note when dealing with management of the PZ in the SL3000 is that the number of cells located in Panels 10 to 13 is determined on the physical partitioning of the SL3000. Only cells within the four panels that are physically assigned to physical partition where LCM is executing are available for the PZ. Further modifying the size of the PZ in the SL3000 is the raw number of cells available based upon the number of drives and other options (CAPs, windows, etc.) installed in the BDM and EDM.

Index

A

ACTION CONSOLIDATE control statement 182
ACTION EJECT control statement 195
ACTION EXPORT control statement 203
ACTION MIGRATE control statement 211
ACTION MOVE control statement 218, 240
ACTION RECALL control statement 188, 226, 233,
241, 246, 247, 252, 253, 260, 267

B

batch job
 creating 23
 EXEC statement 24
 JCL statements 25

C

control statements
 overview 10
creating ExLM parameter files 9

D

data areas
 METHODFILE record 409
 overview 401
 TMCI record 402
DATASET control statement 86, 182
DISPLAY command 381

E

Eject File 128
ExLM
 batch job
 creating 23
 EXEC statement 24
 JCL statements 25
 control statements
 ACTION CONSOLIDATE 182
 ACTION EJECT 195
 ACTION EXPORT 203
 ACTION MIGRATE 211
 ACTION MOVE 218, 240

ACTION RECALL 188, 226, 233, 241, 246, 247,
252, 253, 260, 267

DATASET 86
LOCATION 91
MANAGE PHYSICAL 96
MANAGE VIRTUAL 105
METHOD 106
OPTIONS 114
overview 10
PULLLIST 131
REPORT CELLCNT 277
REPORT CONSOLIDATE 281
REPORT DATASET 321
REPORT EJECT 284
REPORT ENTER 288
REPORT EXPORT 291
REPORT MIGRATE 295, 325, 339
REPORT NONSCRCNT 298
REPORT OPERATOR 305
REPORT RECALL 308, 331
REPORT SCRCNT 311
REPORT SUMMARY 316, 347
SET METHOD 134
TMS CA1 148
TMS COMMON 151
TMS CTT 155
TMS CUSTOM 158
TMS OPEN 162
TMS RMM 166
TMS TLMS 171
UNMANAGED 175

data areas
 METHODFILE record 409
 overview 401
 TMCI record 402
displaying status 381
Eject File 128
management services for Nearline systems 2
management services for VSM systems 3
managing VSM interdependencies 30
operator commands
 DISPLAY 381
 DISPLAY command 381

- MODIFY command 380
- MVS commands 379
- PAUSE command 383
- REDIRECT 385
- RESUME command 386
- STOP command 380
- parameter files
 - syntax 17
- processing 4
- product overview 1
- redirecting ejects from one CAP to another 385
- reports
 - cell count 277, 291
 - consolidation 281
 - custom 14
 - eject 284
 - enter 288
 - export 291
 - guidelines 14
 - migrate 295, 325, 339
 - nonscratch counts 298
 - operator 305
 - overview 12
 - scratch counts 311
 - standard 12
 - summary 316, 347
- resuming CAP ejects, volume moves, and VTV
 - consolidations 386
- SAMPLIB members 389
- stopping 380
- suspending ejects, volumes moves, and VTV
 - consolidations 383
- TMSs
 - running without 127
 - TMS CA1 statement 148
 - TMS COMMON control statement 151
 - TMS CTT control statement 155
 - TMS CUSTOM control statement 158
 - TMS OPEN control statement 162
 - TMS RMM control statement 166
 - TMS TMLS control statement 171
- using
 - to manage Nearline resources 7, 28
 - to manage VSM resources 30
 - to manage VTCS resources 7
 - with TMSs
 - CA-1
 - ejecting volumes deleted from the TMC 45
 - managing data sets 44
 - managing expired volumes 45
 - managing externally managed volumes 45
 - OPTIONS statement parameter processing 46

- overview 38
- scratch subpools 39
- Vault Management System 41
- CA-TLMS
 - OPTIONS statement parameter processing 64
 - overview 57
 - scratch subpools 58
 - Tape Retention System 60
- Custom TMS Interface
 - creating and implementing an interface module 67
 - overview 67
 - vendor-supplied support 72
- DFSMSrmm
 - managing data sets 56
 - managing expired volumes 56
- OPTIONS statement parameter processing 56
 - overview 48
 - scratch subpools 49
- Vital Records Specifications
 - 52
 - guidelines 36
 - overview 35
 - setting up interface to TMS 37

L

- LOCATION control statement 91

M

- MANAGE PHYSICAL control statement 96
- MANAGE VIRTUAL control statement 105
- METHOD control statement 106
- METHODFILE record 409
- MODIFY command 380
- MVCRPT utility 15

N

- NCS
 - pre-installation tasks 1, 7, 8, 9, 389
- Nearline resources
 - using ExLM to manage 28

O

- operator commands
 - DISPLAY command 381
 - MODIFY command 380

- MVS commands 379
- PAUSE command 383
- REDIRECT command 385
- RESUME command 386
- STOP command 380

OPTIONS control statement 114

P

- parameter files
 - syntax 17
- parameters
 - SUBpool 336
 - TOTAL 336
- PAUSE command 383
- pre-installation tasks
 - NCS 1, 7, 8, 9, 389
- PULLLIST control statement 131

R

- REDIRECT command 385
- REPORT CELLCNT control statement 277
- REPORT CONSOLIDATE control statement 281
- REPORT DATASET control statement 321
- REPORT EJECT control statement 284
- REPORT ENTER control statement 288
- REPORT EXPORT control statement 291
- REPORT MIGRATE control statement 295, 325, 339
- REPORT NONSCRCNT control statement 298
- REPORT OPERATOR control statement 305
- REPORT RECALL control statement 331
- REPORT SCRCNT control statement 311
- REPORT SUMMARY control statement 316, 347
- reports
 - custom 14
 - guidelines 14
 - MVCRPT utility 15
 - overview 12
 - standard 12
- RESUME command 386

S

- SAMPLIB members, ExLM 389
- SET METHOD control statement 134
- STOP command 380

T

- TMCI record 402
- TMS CA1 control statement 148
- TMS COMMON control statement 151
- TMS CUSTOM control statement 155, 158
- TMS OPEN control statement 73, 162
- TMS RMM control statement 166

- TMS TLMS control statement 171

U

- UNMANAGED control statement 175

V

- VSM
 - configuration
 - managing ExLM interdependencies 30
- VSM resources
 - using ExLM to manage 30

Glossary

A

ACS. Automated Cartridge System.

ACSs folder (LCM Explorer). A folder that contains the ACS objects that describe the ACSs and their LSM groups that LCM will manage.

ACS object (LCM Explorer). An object that represents an ACS that will be managed by your LCM. An ACS can be managed as a whole or its LSMs can be managed by groups.

ACTION statement. An LCM statement that lets you do *ad hoc* activities including Nearline volume moves and ejects and VTV consolidations.

as needed. A term that refers to the condition where volumes are ejected or moved from a managed LSM when it becomes necessary to do so in order to meet free cell or scratch criteria.

Automated Cartridge System (ACS). A hardware subsystem consisting of a Library Management Unit (LMU) and from 1 to 16 LSMs attached to that LMU.

B

balancing. The LCM process of spreading free cells or scratch volumes among LSMs within an LSM SubGroup.

base name. The portion of a generation data set true or full name that constitutes the generation data group (GDG) base entry. A base name does not include a generation or version number.

blank location code. A location code that denotes the main library location for the CA-1 tape management system.

blank vault name. The null or blank out-of-area code assigned by the CA-1 Vault Management System to volumes stored at the CA-1 main tape library location. This is also referred to as the null vault name.

C

CA-TLMS. Computer Associates Tape Management System. Third-party software by Computer Associates International, Inc.

CA-1. Computer Associates Tape Management System. Third-party software by Computer Associates International, Inc.

CAP. Cartridge Access Port.

cartridge. A computer tape enclosed in a plastic housing.

Cartridge Access Port (CAP). An assembly located on the door of an LSM that allows multiple cartridges to be loaded or unloaded by an operator.

CDS. Control Data Set.

configuration file. A data set that contains LCM configuration objects and describes how LCM should manage ACS content. The data set is created through the use of the LCM Explorer.

consolidation. Using LCM to group VTVs on consolidation MVCs.

client. A functional unit that receives shared services from a server.

cell. A storage slot in an LSM that is used to store a tape cartridge.

CHECK option. An LCM execution option that provides a nondisruptive way in which to test or experiment with LCM.

content management. The process of managing the content of cartridge storage cells in one or more LSMs.

control data set (CDS). The data set used by the HSC to control the functions of an ACS.

controlling data set name. The data set name from the tape management system that is used by LCM when managing LSM content using data set name. Generally this is the first data set on a volume.

copy number. It is possible that multiple copies of the same controlling data set name may exist on different tape volumes. LCM uses the term copy number to designate the ordinal number of an instance of a given data set in a tape management system. Copy number 1 refers to the most recently created copy, copy number 2 refers to the next most recently created copy, and so on. Copy number is used by the METHOD statement in an LCM parameter file.

Cyclesoon volume. A volume with a controlling data set that is due to expire within a specified number of days.

D

data set identifier. A character string that may contain wild cards and represents the names of one or more nongeneration or generation data sets.

DATASET statement. An LCM control statement that provides the capability to specify how LCM should manage the volumes associated with one or more tape data sets.

default LOCATION statement. An LCM LOCATION statement coded to specify how LCM should manage volumes associated with locations that are not defined by specific LOCATION statements.

defective media removal. The LCM process of ejecting nonscratch volumes that have been marked as being defective in the tape management system.

demotion. The process of moving a volume down the hierarchy of LSM groups.

DFSMSrmm. Data Facility System Managed Storage removable media manager.

DISPLAY command. A command issued by a console operator to display overall LCM status, CAP use, and movement information.

distribution. The LCM process of spreading free cells or scratch volumes across multiple LSM SubGroups within an LSM Group.

E

Eject method. A predefined LCM management method that will cause volumes to be ejected from managed LSMs.

LCM Agent. A started task that is used to obtain TMS information from a remote host.

LCM configuration object (LCM Explorer). An object that represents an LCM configuration file and contains all the other LCM objects.

LCM Explorer. A graphical user interface that is used to create a configuration file on the MVS host used to execute LCM runs.

expired volume. A volume whose controlling data set has expired. Expired volumes are also Cyclesoon volumes.

export. Consolidates VTVs (if required) and creates a manifest file that lists the VTVs and MVCs available for export from a VSM system.

externally managed volume. A volume that is defined to the tape management system, but whose use is controlled by some other software system.

ExtendedStore™ LSM. One or more LSMs with no cartridge drives (CDs) that are attached by pass-thru ports to other LSMs (with CDs) in an ACS. These LSMs provide archive storage for cartridges containing less active data sets. Cartridges can be entered and ejected directly into and out of this LSM through either a standard CAP or an enhanced CAP.

F

free cell. A vacant cell to which no volume is assigned by the HSC.

frozen panel. The HSC SET FREEZE utility marks panels “frozen” to prohibit volume movement to or from these panels. You can, however, use the `CLEARFROZENPANELS` parameter of the `OPTIONS` statement to specify that LCM removes volumes from frozen panels in managed LSMs.

G

GENERAL. The name of a tape subpool defined automatically by LCM. Any volume in an LSM that does not belong to a user-defined tape subpool automatically belongs to subpool GENERAL.

generation number. The ordinal number of a generation of a generation data set. LCM refers to the highest (most current) absolute generation number of a generation data set as generation number 1. Generation number is used by the METHOD statement in an LCM parameter file.

H

Host Software Component (HSC). That portion of an Automated Cartridge System (ACS) that executes on host systems attached to the ACS. The HSC provides the interface between the operating system and the rest of the ACS.

HSC. Host Software Component.

HSC scratch status. A status value, scratch or nonscratch, recorded by the HSC for a tape volume.

HSC scratch status synchronization. The LCM process of setting out-of-sync HSC scratch status indicators of volumes to match their eligibility to be mounted in response to scratch mount requests.

HSC Unscratch. The LCM process of setting HSC scratch status indicators for some scratch volumes to 'nonscratch'. This would typically be done to maintain a reserve capacity of scratch volumes in an ExtendedStore™ LSM.

HSC-only volume. A volume defined to the HSC but not defined to a tape management system.

J

JCL. Job Control Language.

L

LIBGEN. The process of defining an ACS configuration to the host software.

library content management. The process of managing the content of cartridge storage cells in one or more LSMs.

Library Storage Module (LSM). Provides a tape cartridge storage cell array plus the robot necessary to move the cartridges.

Local. The LCM default location name for the tape management system main library location.

location. A tape volume storage area that is defined to the tape management system.

location code. An identifier assigned to a tape volume by the tape management system that identifies the intended storage location for that volume.

Locations folder (LCM Explorer). A folder that contains the location objects that correspond to your tape cartridge storage locations.

location ID. A two-character identifier assigned to a tape volume by the CA-TLMS Tape retention System. It identifies the location where the volume is scheduled for storage.

location name. The name of a tape storage location. LCM provides the capability to define location names; unlike location codes, location names are not defined to the tape management system.

Location object (LCM Explorer). An object that represents a tape cartridge storage location based on codes from your tape management system.

LOCATION statement. An LCM control statement used to specify how LCM should manage the volumes associated with a location.

LSM. Library Storage Module.

LSM Group. A collection of one or more LSMs to be managed together as a unit. LSM Groups are defined by the LCM MANAGE control statement.

LSM Group hierarchy. LSM Groups that are defined to have a hierarchical relationship to one another.

LSM id. A three-digit hexadecimal number that uniquely identifies an LSM to a host system.

LSM SubGroup. A collection of one or more LSMs within an LSM Group. LSM Groups may be subdivided into LSM SubGroups for the purpose of specifying separate scratch or free cell quantities for different portions of the LSM Group.

M

main tape library location. The tape management system main library location.

MANAGE statement. An LCM control statement used to define an LSM Group and describe how its content should be managed.

managed LSM. An LSM that is defined to LCM by a MANAGE statement.

management method. Named set of conditions and attributes that are assigned to volumes that controls how LCM will process them.

message log. A data set to which LCM writes informational, warning, and error messages.

METHOD statement. An LCM control statement used to define an LCM management method.

Method object (LCM Explorer). A named collection of conditions and attributes that define how LCM should manage a given collection of volumes.

Methods folder (LCM Explorer). A folder that contains the management methods that determine how LCM manages volumes and has properties that determine how those methods are assigned to **nonscratch volumes**.

Minenter volume. A nonscratch volume that has been entered into an LSM within a specified number of days.

Minref volume. A nonscratch volume that has been referenced within a specified number of days.

Multiple volume cartridge (MVC). A physical cartridge in the LSM that contains one or more virtual tape volumes or no virtual tape volumes, but has been identified as a volume that can be selected for virtual tape volume stacking. The information about the multiple volume cartridge is stored in the HSC control data set.

N

NeverEject method. A predefined LCM management method. LCM will not eject a NEVEREJECT volume from an LSM under any circumstance.

non-LSM scratch volume. A scratch volume that is defined to the tape management system but is not stored in an LSM.

nonmanaged LSM. An LSM that is defined to the HSC but is not defined to LCM by a MANAGE statement. LCM ignores nonmanaged LSMs.

nonscratch volume. A volume not classified as a scratch volume, bad scratch volume, expired volume, or cleaning cartridge.

null vault name. The null or blank out-of-area code assigned by the CA-1 Vault Management System to volumes stored at the CA-1 main tape library location. This is also referred to as the blank vault name.

O

OPTIONS statement. An LCM control statement used to define values for LCM execution parameters and to specify how LCM should manage HSC-only volumes and externally managed volumes.

out-of-area code. A four-character identifier assigned to a tape volume by the CA-1 Vault Management System. It identifies the vault at which the volume is scheduled for storage.

out-of-area volume. A tape volume scheduled for storage by the CA-1 Vault Management System at a location other than the CA-1 main library location.

out-of-sync. If the HSC scratch status indicator for a tape volume does not properly reflect its eligibility to be mounted as a scratch volume, it is said to be out-of-sync with the tape management system.

P

parameter file. A data set that contains LCM control statements and describes how LCM should manage ACS content.

pass-thru. A robotic cartridge movement operation from one LSM to another through a Pass-thru Port.

Pass-thru Port. A mechanism that allows a cartridge to be passed from one LSM to another in a multiple LSM ACS.

PAUSE command. A command issued by a console operator to temporarily pause cartridge ejections and/or movement by LCM.

PickFirst method. A predefined LCM management method. PickFirst volumes in managed LSMs will be picked for ejection or demotion first when room is needed in order to meet free cell or scratch criteria.

PickLast method. A predefined LCM management method. PickLast volumes in managed LSMs will be picked for ejection or demotion last when room is needed in order to meet free cell or scratch criteria.

pick order. The order in which a volume may be picked for ejection or demotion. This is determined by the ORDER attribute of its assigned management method.

promotion. The process of moving a scratch volume up the hierarchy of LSM groups.

property sheets (LCM Explorer). A screen within LCM Explorer that allows you to view and update configuration information.

Pull List object (LCM Explorer). An object that refers to a list of volumes that will be entered into the library after an LCM run. Typically such a list would come from a job scheduling package.

Pull Lists folder (LCM Explorer). A folder that contains the Pull List that list volumes to be entered into the library after an LCM run.

Pull List Volume. A volume that had an entry in the pull list file identified by a PULLLIST statement.

R

Real tape drive (RTD). The physical transport (Timberline or Redwood) controlled by the Virtual Storage Manager (VSM). The transport has a data path to a Virtual Tape Storage Subsystem and may optionally have a data path to MVS or to another **Virtual Tape Storage Subsystem.**

Reports folder (LCM Explorer). A folder that contains the reports that your LCM runs can produce.

Report object (LCM Explorer). An object that represents a report that is defined to the LCM configuration. LCM has a number of predefined standard reports and you can create your own **custom reports**.

REPORT statement. An LCM control statement that provides the capability to control LCM report creation.

RESUME command. A command issued by a console operator to begin, or to resume paused LCM cartridge movement and/or ejection.

Run object (LCM Explorer). An object that describes a particular type of LCM batch processing run that you wish to make. These runs can produce reports and manage your libraries according to your specifications.

S

SCAN option. An LCM execution option that provides the capability to validate the syntax of LCM control statements in a parameter file.

scratch status. A status value associated with a tape volume that indicates whether the volume is suitable for output operations. LCM uses the tape management system volume scratch status if available. Otherwise, it uses the HSC volume scratch status.

scratch volume. A volume that is available for receiving a new tape data set.

slot number. A number assigned to a tape volume by the TMS that can simplify manual cartridge filing and retrieval tasks. The volume slot number, that is printed in both LCM and tape management system reports, may be used to pinpoint the storage place for the volume.

SLUADMIN. HSC software that performs Automated Cartridge System utility functions.

SMF. System Management Facility. An MVS component that records various system activity.

Standard method. A predefined LCM management method that allows volumes to be ejected from managed LSMs as needed in order to meet free cell or scratch criteria. Volumes assigned this method will be picked after **PickFirst** volumes and before **PickLast** volumes. Standard is the management method that will be assigned to nonscratch volumes that have not been assigned a method by any parameter file statements.

Subpools folder (LCM Explorer). A folder that contains the tape subpools you define for LCM to manage.

Subpool object (LCM Explorer). An object that contains a collection of tape volumes you specify by serial number for LCM to manage.

SUBPOOL statement. An LCM control statement used to define a named set of tape volume serial numbers called a tape subpool.

T

tape group. A set of tape volumes that is a unique combination of subpool and media type.

tape library. Traditionally, all computer tapes associated with a data center. LCM regards the set of all tape volumes stored in managed LSMs or under tape management system control as the tape library.

Tape Management Catalog (TMC). A data set used by the CA-1 Tape Management System to record an inventory of the tape library.

tape management system volume scratch status. A status value, scratch or nonscratch, recorded by the tape management system for a tape volume define to that system.

Tape Retention System (TRS). The CA-TLMS tape management system software that provides the capability to define vaults and a vaulting schedule.

tape subpool. A named set of tape volume serial numbers defined by an LCM SUBPOOL control statement.

TMC. Tape Management Catalog.

TMSs folder (LCM Explorer). A folder that contains the TMS objects that identify a tape management system.

TMS object (LCM Explorer). An object that identifies a tape management system that LCM uses to obtain information about volumes.

TMS statement. An LCM control statement used to identify a tape management system and to select processing options specific to it.

transport. An electromechanical device capable of threading tape from a cartridge, moving the tape across the read/write head, and writing data onto or reading data from the tape.

TRS. Tape Retention System.

true name. The full name of an OS data set. The low level qualifier of a generation data set true name identifies a generation and version number.

V

Vault Management System (VMS). The CA-1 tape management system software that provides the capability to define vaults and a vaulting schedule.

vault name. An identifier assigned to a tape volume by the CA-1 Vault Management System that identifies the intended storage site location for the **volume**. Also called an out-of-area code.

vault rotation. A process in which tape volumes are physically moved from one location to another in accordance with a vaulting schedule.

vaulting schedule. A specification for the CA-1 Vault Management System that details the scheduled movement of tape volumes between vaults and the **CA-1 main tape library location**.

Virtual Tape Control System (VTCS). The primary host software that controls activity and information about Virtual Tape Storage Subsystems, virtual tape volumes, real tape drives, and multiple volume cartridges. This software operates in a separate address space from HSC, but communicates closely with HSC.

Virtual tape drive (VTD). A transport in the Virtual Tape Storage Subsystem that emulates a physical 3490E to MVS. The data written to a virtual tape drive is really being written to DASD.

Virtual Tape Storage Subsystem (VTSS). The DASD buffer containing virtual tape volumes and transports. The Virtual Tape Storage Subsystem is a StorageTek RAID 6+ hardware device that emulates 32 or 64 transports. The RAID hardware can read and write “tape” data from or to DASD, and can read **and write data from or to a real tape drive**.

Virtual tape volume (VTV). The emulated “cartridge” whose volume serial number is known to the MVS catalog and the tape management system as a tape data set.

VMF. Volume Master File.

VMS. Vault Management System.

volser number. A character string coded as a single tape volume serial number for a SUBPOOL control statement.

volser range. Two volser numbers, separated by a dash, that are coded for a SUBPOOL statement to define a set of consecutive tape volume serial numbers.

volume. A data carrier that is mounted or demounted as a unit.

Volume Master File (VMF). A data set used by the CA-TLMS tape management system to record an inventory of the tape library.

volume movement schedule. A specification for the CA-TLMS Tape Retention System that details the scheduled movement of tape volumes between offsite locations the CA-TLMS data center location.

volume serial number. A six-character alphanumeric label used to identify a tape volume.

W

wild card. A one- or two-character pattern that may be coded as part of a data set identifier. Wildcards are used to specify a single data set identifier that represents many different data set identifiers.

wizard. A dialog of LCM Explorer that can be invoked to guide you through the process of creating a new configuration or object.