



PART NUMBER
312596901

VERSION NUMBER
6.1

EDITION NUMBER
1

NCS

NEARLINE CONTROL SOLUTION

USER EXIT GUIDE

PRODUCT TYPE
SOFTWARE



Nearline Control Solution

SMC • MVS/HSC • HTTP Server • MVS/CSC • LibraryStation

User Exit Guide

Release 6.1

312596901

Information contained in this publication is subject to change without notice. Comments concerning the contents of this publication should be directed to:

Global Learning Solutions
Storage Technology Corporation
One StorageTek Drive
Louisville, CO 80028-3526
USA

glsfs@stortek.com

Export Destination Control Statement

These commodities, technology or software were exported from the United States in accordance with the Export Administration Regulations. Diversion contrary to U.S. law is prohibited.

Restricted Rights

Use, duplication, or disclosure by the U.S. Government is subject to restrictions as set forth in subparagraph (c) (1) and (2) of the Commercial Computer Software - Restricted Rights at FAR 52.227-19 (June 1987), as applicable.

Limitations on Warranties and Liability

Storage Technology Corporation cannot accept any responsibility for your use of the information in this document or for your use in any associated software program. You are responsible for backing up your data. You should be careful to ensure that your use of the information complies with all applicable laws, rules, and regulations of the jurisdictions in which it is used.

Warning: No part or portion of this document may be reproduced in any manner or in any form without the written permission of Storage Technology Corporation.

Proprietary Information Statement

The information in this document, including any associated software program, may not be reproduced, disclosed or distributed in any manner without the written consent of Storage Technology Corporation.

Should this publication be found, please return it to StorageTek, One StorageTek Drive, Louisville, CO 80028-5214, USA. Postage is guaranteed.

First Edition (February 15, 2005)

StorageTek and the StorageTek logo are trademarks or registered trademarks of Storage Technology Corporation. Other products and names mentioned herein are for identification purposes only and may be trademarks of their respective companies.

© 2005 Storage Technology Corporation. All rights reserved.

Document Effectivity

EC Number	Date	Doc Kit Number	Type	Effectivity
132084	February 15, 2005	---	First Edition	This document applies to the Nearline Control Solution, Version 6.1.

Contents

About this Guide	xiii
Intended Audience	xiii
Reader's Comments	xiii
About the Software	xiii
Conventions Used in this Guide	xiii
Typographic	xiii
Symbols	xiii
How this Guide is Organized	xiv
Related Publications	xv
Technical Support	xvi
Chapter 1. Introduction	1
Overview	1
Virtual Storage Manager (VSM) Support	3
Programming Attributes	3
Chapter 2. HSC Format User Exits	5
Overview	5
HSC User Exits in JES Environments	7
HSC User Exits and Scratch Subpooling	8
Message Handling User Exit (SLSUX01)	9
Functional Description	9
Environment	10
Conditions When Exit Routine is Executed	10
Conditions on Return to HSC From User Exit	10
Programming Considerations	11
Examples	12
Special Considerations	14
Restrictions and Limitations	14
User Exit 01 Parameter List	15
SLSUX01 Cross Reference	16
JES2 Scratch Allocation User Exit (SLSUX02)	17
Functional Description	17
Environment	17
Conditions When Exit Routine is Executed	18
Conditions on Return From User Exit	18

Programming Considerations	19
User Exit 02 Parameter List	20
SLSUX02 Cross Reference	21
Scratch Subpool User Exit (SLSUX03)	22
Functional Description	22
Programming Considerations	23
User Exit 03 Parameter List	24
SLSUX03 Cross Reference	25
JES3 Scratch Allocation User Exit (SLSUX04)	26
Functional Description	26
Environment	26
Conditions When Exit Routine is Executed	26
Conditions on Return From User Exit	27
Programming Considerations	28
User Exit 04 Parameter List	29
SLSUX04 Cross Reference	31
PGMI Authorization User Exit (SLSUX05)	32
Functional Description	32
Environment	32
Conditions When Exit Routine is Executed	32
Conditions on Return To HSC From User Exit	33
Programming Considerations	33
User Exit 05 Parameter List	34
SLSUX05 Cross Reference	34
Insert/Delete User Exit (SLSUX06)	35
Functional Description	35
Environment	35
Conditions When Exit Routine is Executed	35
Conditions on Return To HSC From User Exit	36
Programming Considerations	36
User Exit 06 Parameter List	38
SLSUX06 Cross Reference	39
JES2 Specific Volume Allocation User Exit (SLSUX08)	40
Functional Description	40
Environment	40
Conditions when Exit Routine is Executed	40
Conditions on Return From User Exit	41
Programming Considerations	42
User Exit 08 Parameter List	43
SLSUX08 Cross Reference	44
Deferred Mount User Exit (SLSUX09)	45
Functional Description	45
Environment	46
Conditions When Exit Routine is Executed	46
Conditions on Return From User Exit	47
User Exit 09 Parameter List	48

SLSUX09 Cross Reference	49
JES2 Unit Affinity Separation User Exit (SLSUX10)	50
Functional Description	50
Environment	50
Conditions when Exit Routine is Executed	50
Condition on Return From User Exit	51
Programming Considerations	52
User Exit 10 Parameter List	52
SLSUX10 Cross Reference	54
JES3 Deferred Mount User Exit (SLSUX11)	55
Functional Description	55
Environment	56
Conditions When Exit Routine is Executed	56
Conditions on Return From User Exit	57
User Exit 11 Parameter List	58
SLSUX11 Cross Reference	59
JES3 Unit Affinity Separation User Exit (SLSUX12)	60
Functional Description	60
Environment	60
Conditions When Exit Routine is Executed	61
Conditions on Return From User Exit	61
Programming Considerations	62
User Exit 12 Parameter List	63
SLSUX12 Cross Reference	65
JES3 Specific Volume Allocation User Exit (SLSUX13)	67
Functional Description	67
Environment	67
Conditions when Exit Routine is Executed	67
Conditions on Return From User Exit	68
Programming Considerations	68
User Exit 13 Parameter List	69
SLSUX13 Cross Reference	71
Volume Access User Exit (SLSUX14)	72
Functional Description	72
Environment	72
Conditions When Exit Routine is Executed	72
Conditions on Return to HSC From User Exit	73
Programming Considerations	74
User Exit 14 Parameter List	77
SLSUX14 Cross Reference	79
Command Authorization User Exit (SLSUX15)	81
Functional Description	81
Environment	83
Conditions When Exit Routine is Executed	83
Conditions on Return To HSC From User Exit	83
Programming Considerations	84

User Exit 15 Parameter List	87
SLSUX15 Cross Reference	88
Chapter 3. MVS/CSC Format User Exits	89
Overview	89
MVS/CSC User Exits in JES Environments	90
MVS/CSC User Exits and Scratch Subpooling	91
Message Handling User Exit (SCSUX01)	92
Functional Description	92
Environment	92
Conditions when User Exit Routine is Executed	93
Conditions on Return from User Exit	93
Programming Considerations	94
Examples	94
User Exit 01 Parameter List	96
SCSUX01 Cross Reference	97
JES2 Scratch Allocation User Exit (SCSUX02)	98
Functional Description	98
Environment	98
Conditions when User Exit Routine is Executed	98
Conditions on Return from User Exit	99
Programming Considerations	100
User Exit 02 Parameter List	101
SCSUX02 Cross Reference	102
JES3 Scratch Allocation User Exit (SCSUX04)	103
Functional Description	103
Environment	103
Conditions when User Exit Routine is Executed	103
Conditions on Return from User Exit	104
Programming Considerations	104
User Exit 04 Parameter List	106
SCSUX04 Cross Reference	107
Programmatic Interface Authorization User Exit (SCSUX05)	108
Functional Description	108
Environment	108
Conditions when User Exit Routine is Executed	108
Conditions on Return from User Exit	109
Programming Considerations	109
User Exit 05 Parameter List	110
SCSUX05 Cross Reference	110
JES2 Specific Volume Allocation User Exit (SCSUX08)	111
Functional Description	111
Environment	111
Conditions when User Exit Routine is Executed	112
Conditions on Return from User Exit	112
Programming Considerations	113

User Exit 08 Parameter List	115
SCSUX08 Cross Reference	116
Deferred Mount User Exit (SCSUX09)	117
Functional Description	117
Environment	117
Conditions when User Exit Routine is Executed	118
Conditions on Return from User Exit	118
Programming Considerations	119
User Exit 09 Parameter List	120
SCSUX09 Cross Reference	121
JES2 Unit Affinity Separation User Exit (SCSUX10)	122
Functional Description	122
Environment	122
Conditions when User Exit Routine is Executed	123
Conditions on Return from User Exit	123
Programming Considerations	124
User Exit 10 Parameter List	125
SCSUX10 Cross Reference	127
JES3 Deferred Mount User Exit (SCSUX11)	128
Functional Description	128
Environment	128
Conditions when User Exit Routine is Executed	129
Conditions on Return from User Exit	129
User Exit 11 Parameter List	130
SCSUX11 Cross Reference	131
JES3 Unit Affinity Separation User Exit (SCSUX12)	132
Functional Description	132
Environment	132
Conditions when User Exit Routine is Executed	133
Conditions on Return from User Exit	133
Programming Considerations	134
User Exit 12 Parameter List	135
SCSUX12 Cross Reference	137
JES3 Specific Volume Allocation User Exit (SCSUX13)	139
Functional Description	139
Environment	139
Conditions when User Exit Routine is Executed	140
Conditions on Return from User Exit	140
Programming Considerations	141
User Exit 13 Parameter List	142

Chapter 4. Implementing SMC-Managed User Exits	145
Overview	145
SMC UEXit command	147
Syntax	147
Command Name	147
Parameter Descriptions	147
Example	148
Chapter 5. Implementing HSC-Managed User Exits	149
Overview	149
HSC User Exit (UEXIT) Command and Control Statement	151
Syntax	151
Command Name	151
Parameters	151
Examples	153
Chapter 6. Implementing MVS/CSC-Managed User Exits	155
Overview	155

Tables

Table 1.	NCS 6.1 User Exits	2
Table 2.	HSC Format User Exits	5
Table 3.	HSC User Exits in JES Environments	7
Table 4.	SLSUX01 Return Codes	11
Table 5.	SLSUX01 Return Data in Parameter List	11
Table 6.	SLSUX02 Return Codes	19
Table 7.	SLSUX04 Return Codes	27
Table 8.	SLSUX04 Return Data in Parameter List	28
Table 9.	SLSUX05 Return Codes	33
Table 10.	SLSUX06 Return Codes	36
Table 11.	SLSUX08 Return Codes	41
Table 12.	SLSUX08 Return Data in Parameter List	41
Table 13.	SLSUX09 Return Codes	47
Table 14.	SLSUX10 Return Codes	51
Table 15.	SLSUX10 Return Data in Parameter List	51
Table 16.	SLSUX11 Return Codes	57
Table 17.	SLSUX12 Return Codes	62
Table 18.	SLSUX12 Return Data in Parameter List	62
Table 19.	SLSUX13 Return Codes	68
Table 20.	SLSUX13 Return Data in Parameter List	68
Table 21.	SLSUX14 Return Codes	73
Table 22.	SLSUX14 Return Data in Parameter List	73
Table 23.	Command Security Level	81
Table 24.	SLSUX15 Return Codes	84
Table 25.	SLSUX15 Return Data in Parameter List	84
Table 26.	MVS/CSC Format User Exits	89

Table 27. MVS/CSC User Exits in JES Environments	90
Table 28. SCSUX01 Return Codes	93
Table 29. SCSUX02 Return Codes	99
Table 30. SCSUX04 Return Codes	104
Table 31. SCSUX05 Return Codes	109
Table 32. SCSUX08 Return Codes	113
Table 33. SCSUX09 Return Codes	118
Table 34. SCSUX10 Return Codes	124
Table 35. SCSUX11 Return Codes	129
Table 36. SCSUX12 Return Codes	134
Table 37. SCSUX13 Return Codes	141
Table 38. SMC-Managed User Exits	145
Table 39. HSC-Managed User Exits	149

About this Guide

This guide describes the HSC and MVS/CSC format user exits included with NCS 6.1.



Note: For the purposes of this publication, **HSC** refers to the **MVS** implementation of StorageTek's Host Software Component.

Intended Audience

This publication is intended for NCS system programmers.

Reader's Comments

We'd like to know what you think about this guide. E-mail your comments to us directly. Our Internet address is:

`glsfs@stortek.com`

Be sure to include the part number and title of the guide you are referencing.

About the Software

NCS Release 6.1 is supported by this guide.

Conventions Used in this Guide

Typographic

In the JCL examples in this guide and the sample JCL provided on the installation tape, some fields appear in lower case. You must update these fields to match your installation requirements.

Symbols

The following symbols are used to highlight text in this guide:



Note: Information that may be of special interest to you. Notes are also used to point out exceptions to rules or procedures.



Warning: Information necessary to keep you from damaging your hardware or software.

How this Guide is Organized

This guide contains the following chapters and appendices:

- **Chapter 1, “Introduction”** lists user exits provided with NCS 6.1 and provides programming attributes used when writing custom user exits.
- **Chapter 2, “HSC Format User Exits”** provides detailed information about each HSC format user exit.
- **Chapter 3, “MVS/CSC Format User Exits”** provides detailed information about each MVS/CSC format user exit.
- **Chapter 4, “Implementing SMC-Managed User Exits”** describes how SMC-managed user exits are implemented.
- **Chapter 5, “Implementing HSC-Managed User Exits”** describes how HSC-managed user exits are implemented.
- **Chapter 6, “Implementing MVS/CSC-Managed User Exits”** describes how MVS/CSC-managed user exits are implemented.

Related Publications

The following publications may be included in this package, depending on which NCS product components you ordered:

StorageTek Nearline Control Solution (NCS) Publications

- *NCS (SMC, HSC, HTTP Server, MVS/CSC, LibraryStation) Installation Guide*
- *Requesting Help from Software Support*

StorageTek Storage Management Component (SMC) Publications

- *SMC Configuration and Administration Guide*

StorageTek Host Software Component (MVS/HSC) Publications

- *MVS/HSC Configuration Guide*
- *MVS/HSC Operator's Guide*
- *MVS/HSC System Programmer's Guide*
- *MVS/HSC Messages and Codes Guide*

StorageTek Client System Component (MVS/CSC) Publications

- *MVS/CSC Configuration Guide*
- *MVS/CSC Operator's Guide*
- *MVS/CSC System Programmer's Guide*
- *MVS/CSC Messages and Codes Guide*

StorageTek LibraryStation Publications

- *LibraryStation Configuration Guide*
- *LibraryStation Operator and System Programmer's Guide*
- *LibraryStation Messages and Codes Guide*

StorageTek Virtual Storage Manager Publications

- *VTCS Installation and Configuration Guide*
- *VTCS Administration Guide*
- *VTCS Messages and Codes Guide*
- *VTCS Reference*

Technical Support

StorageTek Software Support and the StorageTek Customer Resource Center (CRC) maintain information about known NCS Release 6.1 product updates. You can contact Software Support or access the CRC for the latest information available concerning product updates (i.e., documentation, PTFs, PUTs).

See the *Requesting Help from Software Support* guide (included in the NCS package) for information about contacting StorageTek for technical support or to request changes to software products. Or, access StorageTek's CRC homepage at:

<http://www.support.storagetek.com>



Note: You must obtain a login ID and password in order to access the CRC. You can request a login ID and password from the CRC homepage.

Chapter 1. Introduction

Overview

NCS 6.1 supports both HSC and MVS/CSC format user exits; user-modified routines designed to influence the behavior of your library environment.

However, those user exits that affect client allocation and message handling functions, previously managed by HSC and/or MVS/CSC, are now invoked and managed by the SMC. The remaining user exits are unchanged, and continue to be handled by the HSC or MVS/CSC.

The following table lists the user exits included with NCS 6.1:



Notes:

- Shaded columns indicate HSC and MVS/CSC user exits now invoked and managed by the SMC.
- User Exit 7 (SLSUX07) is no longer supported.

Table 1. NCS 6.1 User Exits

Exit Number	Exit Name	Description
1	SLSUX01 SCSUX01	Message Handling User Exit
2	SLSUX02 SCSUX02	JES2 Scratch Allocation User Exit
3	SLSUX03	HSC Scratch Subpool User Exit
4	SLSUX04 SCSUX04	JES3 Scratch Allocation User Exit
5	SLSUX05 SCSUX05	Programmatic Interface Authorization User Exit
6	SLSUX06	HSC Insert/Delete User Exit
8	SLSUX08 SCSUX08	JES2 Specific Volume Allocation User Exit
9	SLSUX09 SCSUX09	Deferred Mount User Exit
10	SLSUX10 SCSUX10	JES2 Unit Affinity Separation User Exit
11	SLSUX11 SCSUX11	JES3 Deferred Mount User Exit
12	SLSUX12 SCSUX12	JES3 Unit Affinity Separation User Exit
13	SLSUX13 SCSUX13	JES3 Specific Volume Allocation User Exit
14	SLSUX14	HSC Volume Access User Exit
15	SLSUX15	HSC Command Authorization User Exit

Virtual Storage Manager (VSM) Support

VSM support exists for certain user exits. Refer to your VTCS documentation for more information.

Programming Attributes

Write user exits with the following program attributes in mind:

- A user exit is entered via SYNCH (SVC 12) and its own PRB is created for it. Follow standard OS save area chaining and linkage conventions.
- If the exit uses authorized services it must be link-edited with the authorized attribute 'AC=1'.
- The exit must reside in an authorized library. You can do this by adding the load library to the IEAAPFzz member of SYS1.PARMLIB or by adding the load library to the PROGzz member of SYS1.PARMLIB. You can also authorize the load library dynamically.
- The exit is given control with Storage Key 0 and in Supervisor State.



Note: Because of their privileged status, have HSC user exits reviewed by system auditors conducting any system integrity or security audit.

- The exit must be reentrant and refreshable.
- The exit is loaded in pageable CSA.
- The exit is executed in TCB mode, no locks held.
- In general, user exits are given control with AMODE set to 31. Exceptions to this rule are noted in the detailed descriptions of individual exits.
- In general, user exits are regarded as having RMODE ANY. Exceptions to this rule are noted in the detailed descriptions of individual exits.

If it is necessary to force an RMODE of 24, you must give the exit's load module the RMODE 24 attribute through either the assembler RMODE statement or the link-edit process. The HSC honors the RMODE attribute it finds for the exit's load module. If you do not specify the RMODE attribute during either assembly or link-edit, the default RMODE will be 24. This is normally not a problem, but your exit may contain some special logic that is sensitive to RMODE.

Chapter 2. HSC Format User Exits

Overview

The following table lists the HSC format user exits provided with NCS 6.1 and describes the primary function of each exit.



Note: Shaded columns indicate HSC user exits now invoked and managed by the SMC. These user exits affect client allocation and message handling functions.

Table 2. HSC Format User Exits

Exit	Name	Description	Function
1	SLSUX01	Message Handling User Exit	Facilitates the interface to tape management systems. It is also used to implement scratch subpooling.
2	SLSUX02	JES2 Scratch Allocation User Exit	Used to influence allocation and selection of tape drives to satisfy a nonspecific volume request under JES2.
3	SLSUX03	Scratch Subpool User Exit	Used to define multiple scratch subpools or scratch subpools of different volume label types.
4	SLSUX04	JES3 Scratch Allocation User Exit	Used to influence allocation and selection of tape drives to satisfy a nonspecific volume request under JES3.
5	SLSUX05	Programmatic Interface Authorization User Exit	Implements the performance of authorization checking.
6	SLSUX06	Insert/Delete User Exit	Implements reporting to provide information about volumes added or deleted from the library control data set.
8	SLSUX08	JES2 Specific Volume Allocation User Exit	Used to influence allocation and selection of tape drives to satisfy a specific volume request under JES2.
9	SLSUX09	Deferred Mount User Exit	Allows you to override the default setting and MVS defer the mount of a cartridge on a library drive.
10	SLSUX10	JES2 Unit Affinity Separation User Exit	Allows you to override the default setting, and control GDG or unit affinity separation for a specific GDG ALL or unit affinity chain.
11	SLSUX11	JES3 Deferred Mount User Exit	Allows you to override the default setting and JES3 defer the mount of a cartridge on a library drive.

Table 2. HSC Format User Exits (Continued)

Exit	Name	Description	Function
12	SLSUX12	JES3 Unit Affinity Separation User Exit	Allows you to override the default setting, and control GDG or unit affinity separation for a specific GDG ALL or unit affinity chain.
13	SLSUX13	JES3 Specific Volume Allocation User Exit	Used to influence allocation and selection of tape drives to satisfy a specific volume request under JES3.
14	SLSUX14	Volume Access User Exit	Allows you to invoke security checking for volume access at mount and eject time.
15	SLSUX15	Command Authorization User Exit	Used to ensure command security.



Notes:

- When migrating to a new release of the HSC, you are not required to reassemble your user exits. However, if you choose to do so, StorageTek suggests that user modifications to user exits and other StorageTek-supplied programs be based on the source code shipped in the current release.
- Sample user exits are distributed as follows:
 - SMC managed JES2 user exits and the message handling user exit are distributed in the SMC JES2 SAMPLIB (UXnnHSCn).
 - SMC managed JES3 user exits are distributed in the SMC JES3 SAMPLIB (UXnnHSCn).
 - HSC managed user exits dummy exit source (SLSUXnn) and samples (UXnnSAMn) are distributed in the HSC SAMPLIB.
- The SMC allows ESOTeric and SUBPool parameters to be specified in the TAPEREQ control statement as well as user exits. Customers should examine their user exits to determine whether they could be replaced with TAPEREQ parameters. Control statements can also be used to control affinity separation policy and defer policy. Refer to the *Storage Management Component (SMC) Configuration and Administration Guide* for information on TAPEREQ and user exit interaction.

HSC User Exits in JES Environments

The following table provides a reference for determining the applicability of any HSC format user exit function within a JES environment.

Table 3. HSC User Exits in JES Environments

User Exit Function	JES2	JES3
Deferred Mount	SLSUX09	SLSUX09 SLSUX11
Influence Device Allocation for Scratch Volume Requests	SLSUX02	SLSUX04
Influence Device Allocation for Specific Volume Requests	SLSUX08	SLSUX13
Esoteric Substitution or Unit Affinity Separation for Affinity Chains	SLSUX10	SLSUX12



Note: All other user exits are applicable regardless of the JES running.

HSC User Exits and Scratch Subpooling

Tape management systems such as CA-1 (TMS), CA-DYNAM/TLMS, DFSMSrmm, and Zara allow definition of relationships between job names or data set names and tape or cartridge volume serial numbers. This concept is sometimes referred to as scratch subpooling. When it is employed, the tape management system only allows certain nonspecific (scratch) mounts to be satisfied by volumes in qualified scratch subpools.

Scratch subpooling is supported in the HSC through user exits.

- User Exits SLSUX01, SLSUX02, SLSUX03, and SLSUX04 are used to implement scratch subpooling.
- SLSUX01 may be called by the SMC at volume mount time to select a scratch volume. The subpool information provided by SLSUX01 allows the selection of a tape volume from the correct subpool.



Note: You must code either the SMC TAPEREQ SUBPool parameter or the SLSUX01 user exit regardless of whether you are using a tape management system or one of the HSC methods for scratch subpooling.

- SLSUX02 may be called by the SMC at device allocation time to select a device in the LSM containing the most scratch volumes of the correct subpool type. The subpool information provided by SLSUX02 allows the selection of a tape drive in the LSM with the most scratch volumes of the correct subpool type. SLSUX02 is used in a JES2 or JES3 (without device setup) environment.
- SLSUX03 is called by HSC at initialization time to define the scratch subpools. Scratch subpools may be defined to the HSC using the SCRPOol control statement in the PARMLIB data set. Using this method is preferable to specifying scratch subpool names through SLSUX03.

For more information on using the SCRPOol control statement, refer to the *HSC System Programmer's Guide*.

- SLSUX04 performs the same function as SLSUX02 for a JES3 environment with SETUP.



Note: The *HSC System Programmer's Guide* provides additional information about the SCRPOol control statement and operator commands used to work with scratch subpools.

Message Handling User Exit (SLSUX01)

Functional Description

The SMC requests HSC library actions by receiving and analyzing system console messages. If the message is of use to the SMC, for example, an MVS mount message, the SMC extracts the necessary information from the message, such as the VOLSER and drive address, and sends this information to the HSC to direct the library hardware to perform the requested action.

User Exit 01 provides the facility the customer can use to change or enhance actions taken on intercepted messages. UX01 operates only on intercepted messages, either those defined by default (Refer to the *SMC Configuration and Administration Guide*), or those defined by the SMC USERMsg command. The user exit requests a specific SMC action by returning appropriate values to the SMC in the form of a parameter list.

There are two principal applications for User Exit 01:

- Request the SMC to take action for messages other than those automatically intercepted by the SMC. You may have a tape management system that issues special messages requiring the SMC to take a certain action. User Exit 01 intercepts console messages requiring action, and uses the User Exit 01 parameter list to instruct the SMC to perform the required action.



Note: Several messages for tape management systems are automatically intercepted. Refer to the *SMC Configuration and Administration Guide* for information about the USERMsg command, which adds messages to the list sent to SLSUX01.

- Support scratch subpooling in response to a Mount message requesting a scratch tape.

A subpool requested via TAPEREQ overrides a subpool requested via UX01. If neither TAPEREQ nor UX01 is specified, the SMC uses the subpool name in the TMS mount message for scratch processing. If no subpool is available through TAPEREQ, UX01, or the mount message, the HSC mounts any compatible scratch tape available.

Using User Exit 01, you can examine the Mount message and according to the exit code defined criteria (jobname, etc.), specify through the User Exit 01 parameter list that the scratch tape selected to satisfy the request must be chosen from a specified subpool of available scratch tapes. The VOLSERs contained in a particular scratch pool are defined using User Exit 03 or the HSC PARMLIB SCRPOOL control statement.

Environment

This user exit is applicable in both JES2 and JES3 environments. It is invoked by the SMC, and executes on the host where the SMC resides.

This user exit is invoked for every WTO or WTOR intercepted by the SMC. It is loaded using the SMC UEXit operator command. See page 147 for more information about this command.



Note: This user exit must reside in a library accessible to the subsystem (SMC STEPLIB, JOBLIB, or your system's LINKLIB concatenation).

Conditions When Exit Routine is Executed

Parameter List

The parameter list is mapped by macro SLSUX01P.

Entry Specifications

Upon entry to SLSUX01, register contents are as follows:

Register	Contents
0	Undefined
1	Pointer to parameter list
2-12	Undefined
13	Pointer to register save area
14	Return address
15	Entry point address

Conditions on Return to HSC From User Exit

Return Specifications

On return from SLSUX01, register contents are as follows:

Register	Contents
0-14	Values at entry to exit
15	Return code (hexadecimal)

Return Codes

Table 4. SLSUX01 Return Codes

Return Code	Name	Description
0	UX01HSC	SMC to interpret the message
4	UX01ACTN	Message interpreted by the user exit. SMC acts per user exit direction.
64	UX01NOPR	The user exit is inactive

Table 5. SLSUX01 Return Data in Parameter List

Name	Description
UX01FUNC	Function code if return code UX01ACTN is issued.
UX01FUNT	Mount/dismount/swap FROM unit address if return code UX01ACTN is issued.
UX01LABT	Label type if return code UX01ACTN is issued.
UX01OPIN	Operator intervention flag if return code UX01ACTN is issued.
UX01SNAM	Scratch subpool name if return code UX01ACTN is issued.
UX01SSUB	Scratch subpool index if return code UX01ACTN is issued.
UX01TUNT	TO unit address if return code UX01ACTN is issued.
UX01VOLS	Volume serial number of cartridge if return code UX01ACTN is issued.
<p>Note: If you define scratch subpools by using SCRPOOL statements in SLSSYSxx PARMLIB member (the preferred method), specify UX01SNAM. If you define scratch subpools by using SLSUX03, specify UX01SSUB.</p>	

Programming Considerations

This exit is invoked in both JES2 and JES3 environments. In these environments, field UX01WQE in the parameter list mapped by SLSUX01P contains the pointer to the MVS WQE.

The exit routine should examine each message and set the operation to be performed in UX01FUNC, and then fill in the appropriate fields which apply to the function.

StorageTek samples include UX01HSC.

Examples

Mount Nonspecific Volume

In the following example, the user exit is set to mount a nonspecific volume of the library label type.

```
set UX01FUNC to C'1'.
set UX01VOLS to 'SCRATCH' or 'PRIVAT'.
set UX01FUNT to drive address.
set UX01SSUB to zero.
set UX01LABT to UX01DFLT.
```

Mount Nonspecific Volume from Scratch Subpool

In the following example, the user exit is set to mount a nonspecific volume from a scratch subpool of the library label type.

```
set UX01FUNC to C'1'.
set UX01VOLS to 'SCRATCH' or 'PRIVAT'.
set UX01FUNT to drive address.
set UX01SSUB to subpool index.
set UX01LABT to UX01DFLT.
```

Mount Nonspecific Volume from Scratch Subpool

In the following examples, the user exit is set to mount a nonspecific volume from a scratch subpool with a label type different than the library label type.

```
set UX01FUNC to C'1'.
set UX01VOLS to 'SCRATCH' or 'PRIVAT'.
set UX01FUNT to drive address.
set UX01SNAM to subpool name.
```

```
set UX01FUNC to C'1'.
set UX01VOLS to 'SCRATCH' or 'PRIVAT'.
set UX01FUNT to drive address.
set UX01SSUB to subpool index.
set UX01LABT to label type.
```

Mount Specific Volume

In the following example, the user exit is set to mount a specific volume.

```
set UX01FUNC to C'1'.
set UX01VOLS to appropriate VOLSER for specific request.
set UX01FUNT to drive address.
set UX01LABT to label type.
```

Dismount Volume

In the following example, the user exit is set to dismount a volume.

```
set UX01FUNC to C'2'.
set UX01FUNT to drive address.
set UX01DISP to disposition.
```

Swap Volume

In the following example, the user exit is set to swap a volume.

```
set UX01FUNC to C'3'.
set UX01FUNT to FROM drive address.
set UX01TUNT to TO drive address.
```

Operator Intervention on a mount

In the following example, the user exit is set to allow operator intervention on a mount.

```
set UX01FUNC to C'1'.
set UX01OPIN to UX010N.
set UX01VOLS to volume serial number.
set UX01FUNT to FROM drive address.
set UX01TUNT to TO drive address.
set UX01LABT to label type.
```

No Operation

In the following example, the user exit is set to bypass all processing of and for this message.

```
set UX01FUNC to C'5'.
```

Special Considerations

Operator intervention is only supported on mount requests. It is not supported for dismount requests or for subsequent messages.

Setting the function code (UX01FUNC) to NOP (no operation) results in all SMC processing of the message being bypassed.

The user exit parameter list SLSUX01P and the MVS WQE, which are pointed to by UX01WQE, reside above the 16M line. The storage is not accessible to programs that are running with AMODE=24.

Restrictions and Limitations

The exit should take care not to issue any messages intercepted by the SMC. Otherwise, a loop in message processing may occur. Additionally, I/O services including: OPEN, CLOSE, READ, WRITE, etc. should be avoided.



Note: MVS/ESA 5.2 and above requires 4-digit UCBs. If your version of SLSUX01 contains 3-digit UCBs, you must recode this exit using 4-digit UCBs.

User Exit 01 Parameter List

The parameter list is built by the NCS message intercept program prior to invoking the user exit. It contains the address of the WQE (the MVS Write Queue Element) containing a message. The user exit can inspect the message and request specific actions by setting the appropriate values and the return code to UX01ACTN.

SLSUX01 Map

Offsets		Type/Value	Len	Name	Description
Dec	Hex				
0	(0)	STRUCTURE	60	SLSUX01P	User Exit 01 Parameter List
0	(0)	ADDRESS	4	UX01WQE	Address of MVS WQE
4	(4)	CHARACTER	1	UX01FUNC	Function code
		'F1'		UX01MNT	Mount a cartridge.
		'F2'		UX01DMNT	Dismount a cartridge.
		'F3'		UX01SWAP	Swap a cartridge from XXX to YYY.
		'F5'		UX01NOP	No operation to be performed.
5	(5)	BITSTRING	1	UX01OPIN	Operator intervention flag
		...1....		UX01ON	Operator intervention requested.
6	(6)	CHARACTER	6	UX01VOLS	Volume serial number of cartridge
12	(C)	HEXSTRING	10	*	Reserved
22	(16)	CHARACTER	1	UX01DISP	Disposition of volume
		'K'		UX01KEEP	Keep volume.
		'D'		UX01DELT	Delete volume.
23	(17)	BITSTRING	1	UX01LABT	Label type
			UX01DFLT	Library default label type
	1		UX01SL	Standard label
	1.		UX01AL	ANSI label
	11		UX01NL	Nonlabeled
	1..		UX01NSL	Nonstandard label
24	(18)	CHARACTER	4	UX01FUNT	Mount/Dismount/Swap "from" unit address
28	(1C)	CHARACTER	4	UX01TUNT	"To" unit address
32	(20)	HEXSTRING	1	UX01SSUB	Scratch subpool number
33	(21)	HEXSTRING	7	*	Reserved
40	(28)	CHARACTER	13	UX01SNAM	Scratch subpool name
56	(38)	FULLWORD	4	UX01WORD	Customer field; initially zero; preserved across calls
60	(3C)			UX01L	Length of SLSUX01P

SLSUX01 Cross Reference

Name	Hex Offset	Hex Value
SLSUX01P	0	
UX01ACTN		04
UX01AL		02
UX01CSC		00
UX01DELT		C4
UX01DFLT		00
UX01DISP	16	
UX01DMNT		F2
UX01FUNC	4	
UX01FUNT	18	
UX01HSC		00
UX01KEEP		D2
UX01L		3C
UX01LABT	17	
UX01MNT		F1
UX01NL		03
UX01NOP		F5
UX01NOPR		40
UX01NSL		04
UX01ON		16
UX01OPIN	5	
UX01SL		01
UX01SNAM	28	
UX01SSUB	20	
UX01SWAP		F3
UX01TUNT	1C	
UX01VOLS	6	
UX01WORD	38	
UX01WQE	0	

JES2 Scratch Allocation User Exit (SLSUX02)

Functional Description

The JES2 Scratch Allocation User Exit enables you to request the modification of actions taken by the SMC during allocation of a nonspecific (scratch) volume DD statement which references cartridge tape devices on a JES2 system. This exit can be used to:

- request allocation to a particular library subsystem as defined by the SMC LIBRARY command.
- request allocation of library drives
- request allocation of nonlibrary drives
- request allocation to prefer library drives over nonlibrary drives, but not exclude nonlibrary drives
- change esoteric (unit name) used for device allocation
- request allocation of a particular ACS
- request allocation to preference LSMs based on LSM type (LSMPREF)
- request allocation to use LSM preferencing when scratch volumes available reach a defined level (LOWSCR)
- supply scratch subpool information for allocation.

Environment

This user exit is applicable in JES2 environments. It is invoked by the SMC, and executes on the host where the SMC resides.

This user exit is invoked by the SMC for every allocation request for a nonspecific volume on a cartridge tape device. It is loaded using the SMC UEXIT operator command. See page 147 for more information about this command.



Note: This user exit must reside in a library accessible to the subsystem (SMC STEPLIB, JOBLIB, or you system's LINKLIB concatenation).

Conditions When Exit Routine is Executed

Entry Specifications

Upon entry to SLSUX02, register contents are as follows:

Register	Contents
0	Undefined
1	Pointer to parameter list
2-12	Undefined
13	Pointer to register save area
14	Return address
15	Entry point address

Parameter List

The parameter list is mapped by macro SLSUX02P.

Execution Attributes

Shared enqueues are held on major name SYSIEFSD and minor names Q4, CHNGDEVS, DDRTPUR, and DDRDA.

Conditions on Return From User Exit

Return Specifications

On return from SLSUX02, register contents are as follows:

Register	Contents
0-14	Values at entry to exit
15	Return code (hexadecimal)

Return Codes

Table 6. SLSUX02 Return Codes

Return Code	Name	Description
0	UX02HSC	Perform default HSC allocation action
4	UX02LIB	Use library drives
8	UX02NLIB	Use nonlibrary drives
12	UX02LIBP	Prefer library drives
16	UX02ESUB	Change the esoteric (unit name) to be used for the allocation
20	UX02ASUB	Request the allocation to the specified ACS
24	UX02LS	Change the LSMYPREF parameter value
28	UX02LO	Change the LOWSCR parameter value
32	UX02VIRT	Select a virtual drive
64	UX02IACT	The user exit is inactive

Programming Considerations

- Because the exit executes as an extension to the common allocation SSREQ, it cannot issue dynamic allocation requests.
- If your SMC accesses multiple libraries, you must code the UX02LIBN library name if you also code an ACS ID. The return code “Use Library Drives” is interpreted to mean use drives in any library. The return code “Use Nonlibrary Drives” is interpreted to mean use only drives not defined in any library.
- Do not attempt to use return code 12 (UX02LIBP) if you have nonlibrary transports with cartridge scratch loaders (CSLs) installed. If MVS allocation detects the presence of CSL transports, it ignores the effects of SMC device preferencing, and the CSL transports are preferred for scratch mounts. If all CSL transports are in use, then the preference established by the SMC is honored.

User Exit 02 Parameter List

The parameter list is built for a nonspecific allocation request. The return code from the user exit indicates the technique which SMC allocation should use for the unit selection(s). When the allocation technique indicates a library drive, the user exit can qualify the selection by a scratch subpool, or a scratch subpool and label type.

SLSUX02 Map

Offsets		Type/Value	Len	Name	Description
Dec	Hex				
0	(0)	STRUCTURE	152	SLSUX02P	User Exit 02 Parameter List
0	(0)	CHARACTER	4	UX02UX02	Eyecatcher 'UX02'
4	(4)	FULLWORD	4	UX02LEN	Length of UX02 parameter list
8	(8)	HEXSTRING	1	UX02SUBP	Storage subpool number
		'E6'		UX02SPID	Subpool 230
9	(9)	HEXSTRING	1	UX02KEY	Storage key.
10	(A)	HEXSTRING	2	*	Reserved
12	(C)	CHARACTER	8	UX02JOBN	Job name
20	(14)	CHARACTER	8	UX02STPN	Step name
28	(1C)	CHARACTER	8	UX02PRSN	Procedure step name
36	(24)	CHARACTER	8	UX02DDN	DD name
44	(2C)	ADDRESS	4	UX02JACC	Address of job accounting information
48	(30)	ADDRESS	4	UX02SACC	Address of step accounting information
52	(34)	CHARACTER	44	UX02DSN	Dataset name
96	(60)	HEXSTRING	1	UX02SSUB	Scratch subpool
97	(61)	BITSTRING	1	UX02LABT	Label type
			UX02LBDF	Library default label type
	1		UX02LBSL	Standard label
	1.		UX02LBAL	ANSI label
	11		UX02LBNL	Nonlabeled
	1..		UX02LBNS	Nonstandard label
98	(62)	CHARACTER	3	UX02XPDT	Dataset expiration date from JFCB
101	(65)	HEXSTRING	3	*	Reserved
104	(68)	FULLWORD	4	UX02USER	Customer field; initially zero; preserved across calls
108	(6C)	CHARACTER	8	UX02ESO	Area to return an esoteric name
116	(74)	HEXSTRING	1	UX02ACS	Area to return an ACS ID
117	(75)	CHARACTER	13	UX02SNAM	Scratch subpool name
132	(84)	ADDRESS	4	UX02JFCB	Address of the JFCB
136	(88)	BITSTRING	1	UX02LSMP	LSMPREF override
			UX02LSNO	None
	1		UX024410	4410 = CIMARRON
	11		UX029360	9360 = WOLFCREEK
	1..		UX029310	9310 = POWDERHORN
137	(89)	BITSTRING	1	UX02LOWS	LOWSCR override
			UX02LONO	None
		1111 1111		UX02LOAN	Any
138	(8A)	HEXSTRING	6	*	Reserved
144	(90)	CHARACTER	8	UX02LIBN	Override library name
152	(98)			UX02LSTL	Length of SLSUX02P

SLSUX02 Cross Reference

Name	Hex Offset	Hex Value
SLSUX02P	0	
UX02ACS	74	
UX02ASUB		14
UX02DDN	24	
UX02DSN	34	
UX02ESO	6C	
UX02ESUB		10
UX02HSC		00
UX02IACT		40
UX02JACC	2C	
UX02JFCB	84	
UX02JOBN	C	
UX02KEY	9	
UX02LABT	61	
UX02LBAL		02
UX02LBDF		00
UX02LBNL		03
UX02LBNS		04
UX02LBSL		01
UX02LEN	4	
UX02LIB		04
UX02LIBN	90	
UX02LIBP		0C
UX02LO		1C
UX02LOAN		FF
UX02LONO		00
UX02LOWS	89	
UX02LS		18
UX02LSMP	88	
UX02LSNO		00
UX02NLIB		08
UX02PRSN	1C	
UX02SACC	30	
UX02SNAM	75	
UX02SPID		E6
UX02SSUB	60	
UX02STPN	14	
UX02SUBP	8	
UX02USER	68	
UX02UX02	0	
UX02VIRT		20
UX02XPDT	62	
UX024410		01
UX029310		04
UX029360		03

Scratch Subpool User Exit (SLSUX03)

Functional Description

The Scratch Subpool User Exit allows you to define multiple scratch subpools, or scratch subpools of different label types.



Notes:

1. The preferred method for defining scratch subpools involves using the Scratch Subpool (SCRPOol) control statement to define subpool names for HSC in PARMLIB. For more information on using the Scratch Subpool control statement, refer to the *HSC System Programmer's Guide*.
2. If scratch subpools are defined in both PARMLIB and SLSUX03, the PARMLIB definitions are used.

SLSUX03 is usually used with SLSUX01 and SLSUX02/SLSUX04 to implement scratch subpooling. Each user exit's roles are as follows:

- SLSUX03 defines the scratch subpools — it associates a particular group or range of VOLSERS as members in a particular subpool. The subpool is identified by either a name or a number.
- SLSUX01 is invoked for each Mount request and is used to inform the HSC which subpool to choose the scratch volume from for the request. SLSUX01 influences the choice of an appropriate scratch volume.
- SLSUX02/SLSUX04 is invoked as part of the process of allocating a drive to satisfy each mount request for a scratch volume. When a subpool is returned by SLSUX02/SLSUX04, the SMC preferences allocation of drives attached to LSMs that contain the most scratch volumes of the designated scratch subpool.

The combination of the user exit functionality described permits mounting of scratch tapes from specified scratch subpools in response to scratch mount requests and minimizes the number of pass-thrus required to satisfy the request.

Programming Considerations

Message Resulting From User Exit Failures

Any errors or inconsistencies in returns from the user exit, such as attempting to return more entries than initially specified or subpool entry definitions being returned out of order (by subpool index) cause display of a console error message and terminate HSC initialization. The following message is displayed if an error is detected:

```
SLSxxxxI - Module SLSVINIT return code 40Fx40Fx
```

The return code, 40Fx40Fx, in the message can have any of the following possible values:

40F540F5	Incorrect number of subpool entries/indices returned.
40F640F6	Subpool entries returned out of subpool index order.
40F740F7	Invalid volume serial number range.
40F840F8	Invalid label type.
40F940F9	Subpool already defined.

Special Considerations

Different hosts in a multi-host complex may have different subpool definitions; separate initializations of the tape management system may change subpool definitions. Each time a tape management system's scratch subpool definitions change, the HSC should also be reinitialized, perhaps with a new Scratch Subpool User Exit.

Restrictions and Limitations

It is permissible to READ and/or WRITE files in this user exit. Users may want to include DD statements in the HSC startup procedure for any tape management system data sets that may need to be referenced.

User Exit 03 Parameter List

The parameter list is passed to the scratch subpool user exit to obtain the scratch subpool definitions for the installation. If an installation's user exit is going to return scratch subpool definitions, the fields defining the number of subpools and number of subpool entries must be supplied along with the first subpool entry definition. After that, each subsequent call to the user exit returns a single subpool entry. Entries must be returned in subpool index order starting with 1 to a maximum of 255.

SLSUX03 Map

Offsets		Type/Value	Len	Name	Description
Dec	Hex				
0	(0)	STRUCTURE	48	SLSUX03P	User Exit 03 Parameter List
0	(0)	CHARACTER	4	UX03HDR	Eyecatcher
4	(4)	ADDRESS	4	UX03USER	Customer field; initially zero; preserved across calls
8	(8)	BITSTRING	1	UX03STAT	User exit call status
			UX03INIT	Initial call to user exit
	1		UX03SECD	Secondary call to user exit
9	(9)	BITSTRING	1	UX03SUBN	Number of subpools
10	(A)	HALFWORD	2	UX03ENTN	Number of subpool entries
12	(C)	HEXSTRING	1	UX03SUBP	Subpool index
13	(D)	CHARACTER	6	UX03LOVS	Low VOLSER
19	(13)	CHARACTER	6	UX03HIVS	High VOLSER
25	(19)	BITSTRING	1	UX03LABL	Label type
			UX03LBDF	Library default label
	1		UX03LBSL	Standard label (SL)
	1.		UX03LBAL	ANSI label (AL)
	11		UX03LBNL	Nonlabeled (NL)
	1..		UX03LBNS	Nonstandard label (NSL)
26	(1A)	HEXSTRING	1	*	Reserved
27	(1B)	CHARACTER	13	UX03SNAM	Subpool name
40	(28)	CHARACTER	8	UX03OWNR	Subpool owner
48	(30)			UX03LSTL	Length of SLSUX03P

SLSUX03 Cross Reference

Name	Hex Offset	Hex Value
SLSUX03P	0	
UX03ENTN	A	
UX03HDR	0	
UX03HIVS	13	
UX03INIT		00
UX03LABL	19	
UX03LBAL		02
UX03LBDF		00
UX03LBNL		03
UX03LBNS		04
UX03LBSL		01
UX03LOVS	D	
UX03LSTL		30
UX03OWNR	28	
UX03SNAM	1B	01
UX03STAT	8	
UX03SUBN	9	
UX03SUBP	C	
UX03USER	4	

JES3 Scratch Allocation User Exit (SLSUX04)

Functional Description

The JES3 Scratch Allocation User Exit enables you to request modification of the actions the SMC takes during allocation of a nonspecific (scratch) volume DD statement which references cartridge tape devices on a JES3 system. This exit can be used to:

- request allocation to a particular library subsystem as defined by the SMC LIBRARY command.
- request allocation of library drives
- request allocation of nonlibrary drives
- request allocation to prefer certain LSM types over others (LSMpref)
- supply scratch subpool information for allocation (when using library drives)
- change esoteric (unit name) used for device allocation
- request allocation of a particular ACS.

Environment

This user exit is applicable during both drive exclusion and drive prioritization. It is invoked by SMC, and executes on the host where the SMC resides.

This user exit is invoked by the SMC for every nonspecific (scratch) volume requested on a cartridge tape device. It is loaded using the SMC UEXIT operator command. See page 147 for more information about this command.



Note: This user exit must reside in a library accessible to the subsystem (SMC STEPLIB, JOBLIB, or your system's LINKLIB concatenation).

Conditions When Exit Routine is Executed

Entry Specifications

Upon entry to SLSUX04, register contents are as follows:

Register	Contents
0	Undefined
1	Pointer to parameter list
2-12	Undefined
13	Pointer to register save area
14	Return address
15	Entry point address

Parameter List

The parameter list is mapped by macro SLSUX04P.

Conditions on Return From User Exit

Return Specifications

On return from SLSUX04, register contents are as follows:

Register	Contents
0-14	Values at entry to exit
15	Return code (hexadecimal)

Return Codes

Table 7. SLSUX04 Return Codes

Return Code	Name	Description
0	UX04HSC	Take default HSC allocation action
4	UX04LIB	Use library drives
8	UX04NLIB	Use nonlibrary drives
12	UX04REPL	Change the esoteric (unit name) to be used for the allocation
16	UX04SACS	Request the allocation of the specified ACS
20	UX04LS	Change the LSMREF parameter value
24	UX04VIRT	Select a virtual drive
64	UX041ACT	The user exit is inactive

Table 8. SLSUX04 Return Data in Parameter List

Name	Description
UX04ACS	ACS to allocate in if return code UX04SACS is issued.
UX04ESOT	Esoteric to substitute if return code UX04REPL is issued.
UX04LABT	Label type if return code UX04HSC or UX04LIB is issued.
UX04SNAM	Scratch subpool name if return code UX04HSC or UX04LIB is issued.
UX04SSUB	Scratch subpool index if return code UX04HSC or UX04LIB is issued.
Note: If you define scratch subpools by using SCRPOOL statements in SLSSYSxx PARMLIB member (the preferred method), specify UX04SNAM. If you define scratch subpools using SLSUX03, specify UX04SSUB.	

Programming Considerations

- Because the exit executes as an extension to the common allocation SSREQ, it cannot issue dynamic allocation requests.
- If your SMC accesses multiple libraries, you must code the UX04LIBN library name if you also code an ACS ID. The return code “Use Library Drives” is interpreted to mean use drives in any library. The return code “Use Nonlibrary Drives” is interpreted to mean use only drives not defined in any library.

User Exit 04 Parameter List

The parameter list is built during drive exclusion and during drive prioritization. The user exit is called when a nonspecific allocation request occurs during drive exclusion for normal or dynamic allocation (UX04CFLG = 0). The user exit is also called when a nonspecific allocation request occurs during drive prioritization processing (UX04CFLG = UX04DIRA).

SLSUX04 Map

Offsets		Type/Value	Len	Name	Description
Dec	Hex				
0	(0)	STRUCTURE	168	SLSUX04P	User Exit 04 Parameter List
0	(0)	CHARACTER	4	UX04UX04	Eyecatcher 'UX04'
4	(4)	FULLWORD	4	UX04LEN	Length of UX04 parameter list
8	(8)	HEXSTRING	1	UX04SUBP	Storage subpool number
		'E6'		UX04SPID	Subpool 230
9	(9)	HEXSTRING	1	UX04KEY	Storage key.
10	(A)	HEXSTRING	1	UX04CFLG	UX04 call flag
		1... ..		UX04DIRA	Called during JES3 directed allocation
			UX04CI	Called during JES3 converter/interpreter
11	(B)	HEXSTRING	1	UX04FLAG	UX04 general flag used only when called from converter/interpreter
		1... ..		UX04UAFF	Element is member of unit affinity chain
		.1... ..		UX04GAFF	Element is member of a GDGALL group
12	(C)	CHARACTER	8	UX04JOBN	Job name
20	(14)	CHARACTER	8	UX04STPN	Step name
28	(1C)	CHARACTER	8	UX04PRSN	Procedure step name
36	(24)	CHARACTER	8	UX04DDN	DD name
44	(2C)	CHARACTER	44	UX04DSN	Dataset name
88	(58)	HEXSTRING	1	UX04SSUB	Scratch subpool
89	(59)	BITSTRING	1	UX04LABT	Label type
			UX04LBDF	Library default label type
	1		UX04LBSL	Standard label
	1.		UX04LBAL	ANSI label
	11		UX04LBNL	Nonlabeled
	1..		UX04LBNS	Nonstandard label
92	(5C)	FULLWORD	4	UX04USER	Customer field; initially zero; preserved across calls
96	(60)	CHARACTER	8	UX04MAIN	JES3 setup processor
104	(68)	CHARACTER	8	UX04UNIT	JCL unit name
112	(70)	CHARACTER	8	UX04ESOT	Area to return an esoteric name
120	(78)	FULLWORD	4	UX04ACS	Area to return an ACS ID; format: 000000AA, where AA is the ACS number
124	(7C)	CHARACTER	13	UX04SNAM	Scratch subpool name
137	(89)	BITSTRING	1	UX04LSMP	LSMPREF override
			UX04LSNO	None
	1		UX044410	4410 = CIMARRON
	11		UX049360	9360 = WOLFCREEK

SLSUX04

Offsets					
Dec	Hex	Type/Value	Len	Name	Description
	1..		UX049310	9310 = POWDERHORN
138	(8A)	HEXSTRING	2	*	Reserved
140	(8C)	CHARACTER	8	UX04LIBN	Override library name
148	(94)	HEXSTRING	20	*	Reserved
168	(A8)			UX04LSTL	Length of SLSUX04P

SLSUX04 Cross Reference

Name	Hex Offset	Hex Value
SLSUX04P	0	
UX04ACS	78	
UX04CFLG	A	
UX04CI		00
UX04DIRA		80
UX04DDN	24	
UX04DSN	2C	
UX04ESOT	70	
UX04FLAG	B	
UX04GAFF		40
UX04HSC		00
UX04IACT		40
UX04JOBN	C	
UX04KEY	9	
UX04LABT	59	
UX04LBAL		02
UX04LBDF		00
UX04LBNL		03
UX04LBNS		04
UX04LBSL		01
UX04LEN	4	
UX04LIB		04
UX04LIBN	8C	
UX04LS		14
UX04LSMP	89	
UX04LSNO		00
UX04MAIN	60	
UX04NLIB		08
UX04PRSN	1C	
UX04REPL		0C
UX04SACS		10
UX04SNAM	7C	
UX04SPID		E6
UX04SSUB	58	
UX04STPN	14	
UX04SUBP	8	
UX04UAFF		80
UX04UNIT	68	
UX04USER	5C	
UX04UX04	0	
UX04VIRT		18
UX044410		01
UX049310		04
UX049360		03

PGMI Authorization User Exit (SLSUX05)

Functional Description

The Programmatic Interface Authorization User Exit performs authorization checking for PGMI functions. If the user exit disables itself (setting return code UX05NOPR) or abends, the HSC allows all users to issue the QUERY and READ requests. The remaining requests can only be issued by APF-authorized, key 0-7, or supervisor state requestors.

If desired, an installation can use RACF or similar product within the SLSUX05 to perform the authorization.

Environment

This user exit is applicable in both JES2 and JES3 environments. It is invoked by the HSC, and executes in the HSC's address space.

This user exit is invoked by the HSC for all requests received from the programmatic interface. This does not include HSC internal requests (e.g., job processing, utilities). The user exit should evaluate the request and set a return code to indicate if the HSC should permit the request to be executed. The exit is called from a non-space switch PC in the requestor's address space, under the requestor's RB.



Note: This user exit must reside in a library defined in the IEAAPFxx member of the SYS1.PARMLIB.

Conditions When Exit Routine is Executed

Entry Specifications

Upon entry to SLSUX05, register contents are as follows:

Register	Contents
0	Undefined
1	Pointer to parameter list
2-12	Undefined
13	Pointer to register save area
14	Return address
15	Entry point address

Parameter List

The parameter list is mapped by macro SLSUX05P.

Conditions on Return To HSC From User Exit

Return Specifications

On return from SLSUX05, register contents are as follows:

Register	Contents
0-14	Values at entry to exit
15	Return code (hexadecimal)

Return Codes

Table 9. SLSUX05 Return Codes

Return Code	Name	Description
0	UX05ALLOW	Allow the request
4	UX05DENY	Deny the request
64	UX05NOPR	The user exit is inactive

Programming Considerations

A user word is provided in the parameter list. The contents of the word are passed from invocation to invocation of the user exit, and the user exit may change the contents. After an IPL or HSC COLD start, it is initially zero; otherwise it survives across HSC startups. If this user word is used as a pointer, the area pointed to should be in common storage.

The user exit is called once during HSC initialization. In that case the pointer to SLSXREQM (UX05REQA) is zero. This permits the user exit to initialize the user word, if not already initialized.



Note: The user word may not be zero if this is not the first HSC initialization after an IPL or HSC COLD start.

There is no serialization provided. The user exit could be executing simultaneously under two TCBS. The user exit may want to serialize updates to any work area the user word may point to.

User Exit 05 Parameter List

The parameter list is built by user interface routines. The exit routine should examine the parameter list.

- If the user should be allowed to issue the request, register 15 should be set to UX05ALLOW.
- If the request is to be denied, UX05DENY should be set.
- If the exit is not to be called again, UX05NOPR should be set.

SLSUX05 Map

Offsets		Type/Value	Len	Name	Description
Dec	Hex				
0	(0)	STRUCTURE	24	SLSUX05P	User Exit 05 Parameter List
0	(0)	CHARACTER	4	UX05HDR	Eyecatcher
		'UX05'		UX05ID	Eyecatcher constant
4	(4)	FULLWORD	4	UX05LEN	Length of UX05 parameter list
8	(8)	ADDRESS	4	UX05REQA	SCSXREQM parameter list address
12	(C)	FULLWORD	4	UX05USER	Customer field; initially zero; preserved across calls
16	(10)	HEXSTRING	8	*	Reserved
24	(18)			UX05LSTL	Length of SLSUX05P

SLSUX05 Cross Reference

Name	Hex Offset	Hex Value
SLSUX05P	0	
UX05ALLOW		00
UX05DENY		04
UX05HDR	0	
UX05ID		'UX05'
UX05LEN	4	
UX05LSTL		18
UX05NOPR		40
UX05REQA	8	
UX05USER	C	

Insert/Delete User Exit (SLSUX06)

Functional Description

The Insert/Delete User Exit provides you a way to obtain information when a volume is added to or deleted from the control data set.

At HSC initialization, a separate server task is attached that drives the user exit code. When a volume is inserted or deleted, a parameter list is built to describe the action. The server task is then posted to invoke the user code and pass the parameter list along. This parameter list shows the type of entry (insert, delete or HSC purge) and information on the volume, such as: VOLSER, location, status, date/time for insert or last use, and number of times selected.

At HSC termination, the server task is notified that termination is in progress. It creates a dummy parameter list with the UX06FUNC=UX06PURG bit on and passes it to the user code for clean up.

The installation-written exit routine must be named SLSUX06 and must be link-edited into an HSC library. Standard IBM OS linkage conventions must be observed.

Environment

This user exit is applicable in both JES2 and JES3 environments. It is invoked by the HSC, and executes in the HSC's address space.



Notes:

- This exit is **not** active during reconfiguration.
- This user exit must reside in a library defined in the IEAAPFxx member of the SYS1.PARMLIB.

Conditions When Exit Routine is Executed

Entry Specifications

Upon entry to SLSUX06, register contents are as follows:

Register	Contents
0	Undefined
1	Pointer to parameter list
2-12	Undefined
13	Pointer to register save area
14	Return address
15	Entry point address

Parameter List

The parameter list is mapped by macro SLSUX06P.

Conditions on Return To HSC From User Exit

Return Specifications

On return from SLSUX06, register contents are as follows:

Register	Contents
0-14	Values at entry to exit
15	Return code (hexadecimal)

Return Codes

Table 10. SLSUX06 Return Codes

Return Code	Name	Description
0	UX06OK	Normal return
64	UX06NOPR	Cancel exit
255	UX06INV	Invalid function code passed

Programming Considerations

The parameter list (SLSUX06P) is obtained from user key storage.

On initial entry, the UX06USER fullword is set to zero. If the user wants information to be maintained across all calls to the exit, they can GETMAIN a work area storage and place the address of that area in UX06USER. This is the only field in the parameter list that is maintained across exit calls. At termination (UX06FUNC=UX06PURG), the user must release any resources being held and FREEMAIN any obtained storage.

The exit routine should examine the UX06FUNC flag byte to determine the correct entry type.

Example:

```

UX06FUNC = UX06INS - volume inserted in database
UX06FUNC = UX06DEL - volume deleted from database
UX06FUNC = UX06PURG - purge call, cleanup before return

```

Program Attributes

The program attributes of SLSUX06 are as described in “Programming Attributes” on page 3 with the following exceptions:

RMODE=24, AMODE=24

Special Considerations

Since the user code is invoked under a separate TCB, problems are not encountered in the HSC if the exit has problems. It may open files, do I/O, or obtain resources. Upon receiving an entry type of UX06PURG in the parameter list, the user code must clean up resources and terminate.

If the user code is passed an invalid function type, it should return UX06INV in R15.

If the user code decides it does not want to be called again, it should perform all necessary clean up and return UX06NOPR in R15.

The HSC server that invokes the user code enables MVS Dump Analysis and Elimination (DAE) to suppress duplicate SVC dumps. If user code is being tested that abends the same and a dump is needed, it may be necessary to temporarily turn off DAE on the system or to EDIT SYS1.DAE and remove the dump entry that is suppressing the dump.

Restrictions and Limitations

The following restrictions and limitations apply:

- The HSC must be recycled to reactivate the exit.
- If the exit is deactivated or an abend occurs, any transactions not processed are lost.
- The user exit is entered in 24-bit addressing. This is a restriction when calling TMS functions.
- The user exit must be assembled using the HSC and CA-1 (TMS) macro libraries.

Your systems programming staff may replace the default user exit with one designed to implement your system’s specific needs.

User Exit 06 Parameter List

The parameter list is passed to the insert/delete user exit to pass information about the volume serial being added to or deleted from the database.

On the first call to the user code, it may obtain storage and save its address in the user word provided in the parameter list. The value of the user word is maintained across calls.

The user code is invoked for three actions: 1) insert - when a volume is added to the database, 2) delete - when a volume is deleted from the database and 3) purge - when HSC is brought down.

SLSUX06 Map

Offsets		Type/Value	Len	Name	Description
Dec	Hex				
0	(0)	STRUCTURE	60	SLSUX06P	User Exit 06 Parameter List
0	(0)	CHARACTER	4	UX06ID	Eyecatcher 'UX6P'
4	(4)	FULLWORD	0	UX06DESC	Alignment/length
4	(4)	HEXSTRING	1	UX06SPID	Subpool ID
5	(5)	HEXSTRING	3	UX06LEN	Block length
8	(8)	FULLWORD	4	UX06FWD	Forward chain pointer
12	(C)	FULLWORD	4	UX06USER	Customer field; initially zero; preserved across calls
16	(10)	HEXSTRING	4	*	Reserved
20	(14)	BITSTRING	1	UX06FUNC	Exit function flag
		1		UX06INS	Volume inserted in database
		.1		UX06DEL	Volume deleted from database
		..1		UX06PURG	Purge call, clean up before return
21	(15)	HEXSTRING	11	*	Reserved
32	(20)	CHARACTER	6	UX06VOL	Volume serial
38	(26)	BITSTRING	1	UX06FLGS	Label type
		1		UX06SCR	Volume is scratch
		.1		UX06SEL	Volume is selected
		..1		UX06ELAB	Cartridge has external label
		...1		UX06OCR	External label is OCR readable
	1		UX06INUS	Database volume record is valid
39	(27)	HEXSTRING	1	UX06LOCK	Owning host ID
40	(28)	HEXSTRING	3	*	Reserved
43	(2B)	HEXSTRING	5	UX06LOC	Cartridge location
The following date/time values are TOD date/time values obtained from the first fullword of the 64-bit result of a 'TIME STCK' (Store Clock) instruction.					
48	(30)	FULLWORD	4	UX06DATI	Date/time volume inserted
52	(34)	FULLWORD	4	UX06DATL	Date/time last selected
56	(38)	FULLWORD	4	UX06SCNT	Volume selected count
60	(3C)	HEXSTRING	20	*	Reserved
80	(50)			UX06L	Length of SLSUX06P

SLSUX06 Cross Reference

Name	Hex Offset	Hex Value
SLSUX06P	0	
UX06DATI	30	
UX06DATL	34	
UX06DEL		40
UX06DESC	4	
UX06ELAB		20
UX06FLGS	26	
UX06FUNC	14	
UX06FWD	8	
UX06ID	0	
UX06INS		80
UX06INUS		01
UX06INV		FF
UX06LEN	5	
UX06LOC	2B	
UX06LOCK	27	
UX06NOPR		40
UX06OCR		10
UX06OK		00
UX06PURG		20
UX06SCNT	38	
UX06SCR		80
UX06SEL		40
UX06SPID	4	
UX06USER	C	
UX06VOL	20	

JES2 Specific Volume Allocation User Exit (SLSUX08)

Functional Description

The JES2 Specific Volume Allocation User Exit enables you to request modification of the actions the SMC takes during allocation of a specific volume DD statement which references cartridge tape devices on a JES2 system. This exit can be used to:

- request allocation to a particular library subsystem as defined by the SMC LIBRARY command
- change esoteric (unit name) used for device allocation
- request allocation of a particular ACS
- request allocation of nonlibrary drives
- request allocation of library drives
- bypass drive exclusion logic.

Environment

This user exit is applicable in JES2 environments. It is invoked by the SMC, and executes on the host where the SMC resides.

This user exit is invoked by the SMC for every allocation request for a specific volume on a cartridge tape device on a JES2 system. It is loaded using the SMC UEXIT operator command. See page 147 for more information about this command.



Note: This user exit must reside in a library accessible to the subsystem (SMC STEPLIB, JOBLIB, or you system's LINKLIB concatenation).

Conditions when Exit Routine is Executed

Entry Specifications

Upon entry to SLSUX08, register contents are as follows:

Register	Contents
0	Undefined
1	Pointer to parameter list
2-12	Undefined
13	Pointer to register save area
14	Return address
15	Entry point address

Parameter List

The parameter list is mapped by macro SLSUX08P.

Execution Attributes

Shared enqueues held on major name SYSIEFSD, minor names Q4, CHNGDEVS, DDRTPUR, and DDRDA.

Conditions on Return From User Exit

Return Specifications

On return from SLSUX08, register contents are as follows:

Register	Contents
0-14	Values at entry to exit
15	Return code (hexadecimal)

Return Codes

Table 11. SLSUX08 Return Codes

Return Code	Name	Description
0	UX08HJCL	Honor unit information in JCL
4	UX08ESUB	Change the esoteric (unit name) to be used for the allocation
8	UX08SVOL	Request the allocation to use library drives indicated by the SPECVOL parameter of the ALLOC command
12	UX08NLIB	Request allocation to use nonlibrary drives
16	UX08ASUB	Request the allocation of the specified ACS
20	UX08BSEP	Bypass drive exclusion
64	UX08IACT	User exit is not operational

Table 12. SLSUX08 Return Data in Parameter List

Name	Description
UX08ACS	ACS to allocate in if return code UX08ASUB is issued.
UX08ESO	Esoteric to substitute if return code UX08ESUB is issued.

Programming Considerations

- Because the exit executes as an extension to the common allocation SSREQ, it cannot issue dynamic allocation requests.
- If your SMC accesses multiple libraries, you must code the UX08LIBN library name if you also code an ACS ID. The return code “Use Library Drives” is interpreted to mean use drives in any library. The return code “Use Nonlibrary Drives” is interpreted to mean use only drives not defined in any library.

User Exit 08 Parameter List

The parameter list is built by SMC Common Allocation SSREQ processing. The user exit is called for a specific allocation request. The user exit provides the ability to provide allocation criteria for a given DD statement.

SLSUX08 Map

Offsets		Type/Value	Len	Name	Description
Dec	Hex				
0	(0)	STRUCTURE	136	SLSUX08P	User Exit 08 Parameter List
0	(0)	CHARACTER	4	UX08UX08	Eyecatcher 'UX08'
4	(4)	FULLWORD	4	UX08LEN	Length of UX08 parameter list
8	(8)	HEXSTRING	1	UX08SUBP	Storage subpool number
		'E6'		UX08SPID	Subpool 230
9	(9)	HEXSTRING	1	UX08KEY	Storage key.
10	(A)	HEXSTRING	2	*	Reserved
12	(C)	CHARACTER	8	UX08JOBN	Job name
20	(14)	CHARACTER	8	UX08STPN	Step name
28	(1C)	CHARACTER	8	UX08PRSN	Procedure step name
36	(24)	CHARACTER	8	UX08DDN	DD name
44	(2C)	ADDRESS	4	UX08USER	Customer field; initially zero; preserved across calls
48	(30)	ADDRESS	4	UX08JACC	Address of job accounting information
52	(34)	ADDRESS	4	UX08SACC	Address of step accounting information
56	(38)	CHARACTER	44	UX08DSN	Dataset name
100	(64)	ADDRESS	4	UX08VOLP	Address of volume information
104	(68)	FULLWORD	4	UX08NUMV	Number of volumes in dataset
108	(6C)	CHARACTER	8	UX08ESO	Area to return esoteric name
116	(74)	HEXSTRING	1	UX08ACS	Area to return an ACS ID
117	(75)	CHARACTER	3	UX08XPDT	Dataset expiration date
120	(78)	BITSTRING	1	UX08LABT	Label type
		. 1		UX08LBAL	Standard label
	 1 . .		UX08LBNS	ANSI label
	 1 .		UX08LBSL	Nonlabeled
	 1		UX08LBNL	Nonstandard label
121	(79)	HEXSTRING	7	*	Reserved
128	(80)	CHARACTER	8	UX08LIBN	Override library name
136	(88)			UX08FIXL	Length of SLSUX08P

Offsets		Type/Value	Len	Name	Description
Dec	Hex				
0	(0)	STRUCTURE	16	SLSUX08V	User Exit 08 Volume Parm List
0	(0)	CHARACTER	6	UX08VLSR	Volume serial
6	(6)	BITSTRING	1	UX08VLOC	Volume location
		1		UX08VLIB	Volume resides in library
		. 1		UX08VNLB	Volume resides outside library
7	(7)	HEXSTRING	2	UX08LSM	If volume in library, the library location in ACS/LSM format 'AALL' (hexadecimal)

SLSUX08

Offsets		Type/Value	Len	Name	Description
Dec	Hex				
9	(9)	HEXSTRING	7	*	Reserved
16	(10)			UX08VOLL	Length of volume entry

SLSUX08 Cross Reference

Name	Hex Offset	Hex Value
SLSUX08P	0	
UX08ACS	74	
UX08ASUB		10
UX08BSEP		14
UX08DDN	24	
UX08DSN	38	
UX08ESO	6C	
UX08ESUB		04
UX08FIXL		80
UX08HJCL		00
UX08IACT		40
UX08JACC	30	
UX08JOBN	C	
UX08KEY	9	
UX08LABT	78	
UX08LBAL		40
UX08LBNL		01
UX08LBNS		04
UX08LBSL		02
UX08LEN	4	
UX08LIBN	80	
UX08LSM	07	
UX08NLIB		0C
UX08NUMV	68	
UX08PRSN	1C	
UX08SACC	34	
UX08SPID		E6
UX08STPN	14	
UX08SUBP	8	
UX08SVOL		08
UX08USER	2C	
UX08UX08	0	
UX08VLIB		80
UX08VLOC	6	
UX08VLSR	0	
UX08VNLB		40
UX08VOLL		10
UX08VOLP	64	
UX08XPDT	75	

Deferred Mount User Exit (SLSUX09)

Functional Description

The Deferred Mount User Exit is invoked during MVS allocation processing to allow the user to determine whether a mount should be deferred. The exit is only invoked during static allocation. Dynamic allocation requests are always deferred. Checkpoint/restart data sets used for restart are never deferred.



Note: For information on JES3 deferral, refer to “JES3 Deferred Mount User Exit (SLSUX11)” on page 55.

If you request defer in the JCL, the mount of the cartridge is deferred until the data set is opened. If you do not request defer in your JCL, the cartridge is mounted at step allocation time. If the data set is not opened, the cartridge is mounted and dismounted without actually being used.

The SMC ALLOCDef command provides a DEFer option to enable or disable MVS deferred mount processing for library mounts. Refer to the *Storage Management Component (SMC) Configuration and Administration Guide* for more information.

- Setting DEFer(ON) allows you to override the JCL and always request deferred mount processing.
- Setting DEFer(OFF) does not override your JCL or JECL statements requesting MVS or JES3 deferred processing.
- Setting DEFer(JES3) allows you to delay the volume mount until step execution begins (JES3 only).

When deferred mount processing is in effect, a cartridge is only mounted when the data set on the cartridge is opened. If the data set is not opened, the cartridge is not mounted. The LSM robot is then free to perform other necessary tasks. If the volume is required, it is mounted at open time and the job waits until the cartridge is mounted before proceeding.

Cartridges that are mounted are selected by the HSC. Without deferred mounting, scratch volumes that are never used, are mounted and removed from the scratch list. This causes the scratch list to be depleted more quickly than if the HSC did not mount and select these volumes.

Deferred mounting can reduce the number of mounts and dismounts the robot must perform, but may increase the time required to run a job. SLSUX09 provides you with the flexibility to allow or disallow the Defer option on an individual mount request.

If you require some data sets be mounted prior to open time for performance reasons and your data center normally operates in deferred mode, SLSUX09 allows you to override deferred mounting for an individual mount request.

Environment

This user exit is applicable in both JES2 and JES3 environments. It is invoked by the SMC, and executes on the host where the SMC resides.

This user exit is loaded using the SMC UEXit operator command. See page 147 for more information about this command.



Note: This user exit must reside in a library accessible to the subsystem (SMC STEPLIB, JOBLIB, or your system's LINKLIB concatenation).

Conditions When Exit Routine is Executed

Entry Specifications

Upon entry to SLSUX09, register contents are as follows:

Register	Contents
0	Undefined
1	Pointer to parameter list
2-12	Undefined
13	Pointer to register save area
14	Return address
15	Entry point address

Parameter List

The parameter list is mapped by macro SLSUX09P.

Conditions on Return From User Exit

Return Specifications

On return from SLSUX09, register contents are as follows:

Register	Contents
0-14	Values at entry to exit
15	Return code (hexadecimal)

Return Codes

Table 13. SLSUX09 Return Codes

Return Code	Name	Description
0	UX09HSC	Process normally; exit does not influence defer status
4	UX09DFR	Defer the mount
8	UX09NDFR	Honor the JCL defer status
12	UX09NVIR	Do not defer the virtual mount.
64	UX09IACT	The user exit is inactive

User Exit 09 Parameter List

The parameter list is built by SMC Common Allocation SSREQ processing. The user exit is called for a library volume allocation request. The return code from the user exit indicates the MVS defer status of the request.

SLSUX09 Map

Offsets		Type/Value	Len	Name	Description
Dec	Hex				
0	(0)	STRUCTURE	120	SLSUX09P	User Exit 09 Parameter List
0	(0)	CHARACTER	4	UX09UX09	Eyecatcher 'UX09'
4	(4)	FULLWORD	4	UX09LEN	Length of UX09 parameter list
8	(8)	HEXSTRING	1	UX09SUBP	Storage subpool number
		'E6'		UX09SPID	Subpool 230
9	(9)	HEXSTRING	1	UX09KEY	Storage key.
10	(A)	HEXSTRING	2	*	Reserved
12	(C)	FULLWORD	4	UX09USER	Customer field; initially zero; preserved across calls
16	(10)	CHARACTER	8	UX09JOBN	Job name
24	(18)	CHARACTER	8	UX09STPN	Step name
32	(20)	CHARACTER	8	UX09PRSN	Procedure step name
40	(28)	CHARACTER	8	UX09PGMN	EXEC=program name
48	(30)	CHARACTER	8	UX09DDN	DD name
56	(38)	CHARACTER	44	UX09DSN	Dataset name
100	(64)	HEXSTRING	16	*	Reserved
116	(74)	BITSTRING	1	UX09DDCH	Dataset characteristics
		1... ..		UX09SPEC	Specific volume request
		.1... ..		UX09NSPC	Nonspecific volume request
117	(75)	HEXSTRING	3	*	Reserved
120	(78)			UX09LSTL	Length of SLSUX09P

SLSUX09 Cross Reference

Name	Hex Offset	Hex Value
SLSUX09P	0	
UX09DDCH	74	
UX09DDN	30	
UX09DFR		04
UX09DSN	38	
UX09HSC		00
UX09IACT		40
UX09JOBN	10	
UX09KEY	9	
UX09LEN	4	
UX09LSTL		78
UX09NDFR		08
UX09NSPC		40
UX09NVIR		0C
UX09PGMN	28	
UX09PRSN	20	
UX09SPEC		80
UX09SPID		E6
UX09STPN	18	
UX09SUBP	8	
UX09USER	C	
UX09UX09	0	

JES2 Unit Affinity Separation User Exit (SLSUX10)

Functional Description

The JES2 Unit Affinity Separation User Exit enables you to request modification of the actions the SMC takes during allocation of a unit affinity chain or GDG ALL chain which references cartridge tape devices on a JES2 system. This exit can be used to

- override the setting of the SMC ALLOCDef command SEPLvl parameter
- request allocation of library drives for the chain
- request allocation of nonlibrary drives for the chain
- change the esoteric (unit name) used to allocate the chain
- request allocation of a particular ACS for the chain.

Environment

This user exit is applicable in JES2 environments. It is invoked by the SMC, and executes on the host where the SMC resides.

This user exit is invoked by the SMC for every unit affinity chain or GDG ALL chain that requires allocation. It is loaded using the SMC UEXit operator command. See page 147 for more information about this command.



Note: This user exit must reside in a library accessible to the subsystem (SMC STEPLIB, JOBLIB, or your system's LINKLIB concatenation).

Conditions when Exit Routine is Executed

Entry Specifications

Upon entry to SLSUX10, register contents are as follows:

Register	Contents
0	Undefined
1	Pointer to parameter list
2-12	Undefined
13	Pointer to register save area
14	Return address
15	Entry point address

Parameter List

The parameter list is mapped by macro SLSUX10P.

Execution Attributes

Shared enqueues held on major name SYSIEFSD, minor names Q4, CHNGDEVS, DDRTPUR, and DDRDA.

Condition on Return From User Exit

Return Specifications

On return from SLSUX10, register contents are as follows:

Register	Contents
0-14	Values at entry to exit
15	Return code (hexadecimal)

Return Codes

Table 14. SLSUX10 Return Codes

Return Code	Name	Description
0	UX10PLIB	Perform separation according to the SEPLvl parameter of the ALLOCDef or ALLOCJob commands
4	UX10NSEP	Do not separate the chain
8	UX10SEP	Separate the chain
12	UX10LDRV	Allocate library drives, but do not separate the chain
16	UX10NDRV	Allocate nonlibrary drives, but do not separate the chain
20	UX10ESUB	Perform esoteric substitution using the specified esoteric name, but do not separate the chain
24	UX10ASUB	Direct allocation to a specific ACS or MVS/CSC subsystem name, but do not separate the chain
64	UX10IACT	The user exit is inactive

Table 15. SLSUX10 Return Data in Parameter List

Name	Description
UX10ACS	ACS to allocate in if return code UX10ASUB is issued.
UX10ESO	Esoteric to substitute if return code UX10ESUB is issued.

Programming Considerations

- Because the exit executes as an extension to the common allocation SSREQ, it cannot issue dynamic allocation requests.
- This exit can request esoteric substitution (or ACS specification) or separation, but not both. The two requests are mutually exclusive.

Performance Considerations

Unit affinity separation results in more tape devices being allocated to job steps requesting unit affinity between library and nonlibrary volumes, or volumes in different ACSs. Increased resource allocation may affect the overall performance for the entire job mix of an MVS environment.

User Exit 10 Parameter List

The parameter list is built by SMC Common Allocation SSREQ processing. The user exit is called for each unit affinity chain or unqualified GDG specified in the invoking JCL. SLSUX10 provides the ability to request unit affinity separation for data sets which belong to a single affinity chain or an unqualified GDG and the required volumes reside in different physical locations (e.g., inside and outside an ACS).

SLSUX10 Map

Offsets		Type/Value	Len	Name	Description
Dec	Hex				
0	(0)	STRUCTURE	64	SLSUX10P	User Exit 10 Parameter List
0	(0)	CHARACTER	4	UX10UX10	Eyecatcher 'UX10'
4	(4)	FULLWORD	4	UX10LEN	Length of UX10 parameter list
8	(8)	HEXSTRING 'E6'	1	UX10SUBP UX10SPID	Storage subpool number Subpool 230
9	(9)	HEXSTRING	1	UX10KEY	Storage key.
10	(A)	HEXSTRING	2	*	Reserved
12	(C)	CHARACTER	8	UX10JOBN	Job name
20	(14)	CHARACTER	8	UX10STPN	Step name
28	(1C)	CHARACTER	8	UX10PRSN	Procedure step name
36	(24)	ADDRESS	4	UX10USER	Customer field; initially zero; preserved across calls
40	(28)	ADDRESS	4	UX10JACC	Address of job accounting information
44	(2C)	ADDRESS	4	UX10SACC	Address of step accounting information
48	(30)	FULLWORD	4	UX10DCNT	Number of DDs in affinity chain
52	(34)	CHARACTER	8	UX10ESO	Area to return esoteric name
60	(3C)	HEXSTRING	1	UX10ACS	Area to return an ACS ID
61	(3D)	HEXSTRING	3	*	Reserved
64	(40)			UX10FIXL	Length of fixed portion of parameter list

The following area immediately follows the SLSUX10P fixed data area. This area repeats once for each DD statement in the affinity chain. The number of DD statements in the affinity chain is stored in field UX10DCNT.

Offsets		Type/Value	Len	Name	Description
Dec	Hex				
0	(0)	STRUCTURE	80	SLSUX10D	User Exit 10 Dataset Parm List
0	(0)	CHARACTER	8	UX10DDN	DD name
8	(8)	CHARACTER	44	UX10DSN	Dataset name
52	(34)	ADDRESS	4	UX10VOLP	Pointer to volume information
56	(38)	FULLWORD	4	UX10VCNT	Number of volumes in dataset
60	(3C)	CHARACTER	3	UX10XPDT	Dataset expiration date from JFCB
63	(3F)	BITSTRING	1	UX10LABT	Label type from JFCB
		.1		UX10LBAL	ANSI label
	1 . .		UX10LBNS	Nonstandard label
	1 . .		UX10LBSL	Standard label
	1 . .		UX10LBNL	Nonlabeled
64	(40)	BITSTRING	1	UX10GDGI	GDG information
		1		UX10GDG	Dataset is part of GDGALL
		.1		UX10NGDG	Dataset is GDG single
65	(41)	HEXSTRING	15	*	Reserved
80	(50)			UX10DSNL	Length of dataset entry

The following area is pointed to by UX10VOLP. For a specific request, UX10VSER contains the volume serial. For a nonspecific request, UX10VSER contains "SCRATCH". If the specific volume resides in the library, UX10LSM will contain its library location. For all other requests UX10LSM will contain zeros.

Offsets		Type/Value	Len	Name	Description
Dec	Hex				
0	(0)	STRUCTURE	16	SLSUX10V	User Exit 10 Volume Parm List
0	(0)	CHARACTER	6	UX10VLSR	Volume serial
6	(6)	BITSTRING	1	UX10VLOC	Volume location
		1		UX10VLIB	Specific volume resides in library
		. 1		UX10VNLB	Specific volume resides outside library
		. . 1		UX10VSCR	Nonspecific volume request
7	(7)	HEXSTRING	2	UX10LSM	If specific volume in library, the library location in ACS/LSM format 'AALL' (hexadecimal)
9	(9)	HEXSTRING	7	*	Reserved
16	(10)			UX10VOLL	Length of volume entry

SLSUX10

SLSUX10 Cross Reference

Name	Hex Offset	Hex Value
SLSUX10D	0	
SLSUX10P	0	
SLSUX10V	0	
UX10ACS	36	
UX10ASUB		18
UX10DCNT	30	
UX10DDN	0	
UX10DSN	8	
UX10DSNL		50
UX10ESO	34	
UX10ESUB		14
UX10FIXL		40
UX10GDG		80
UX10GDGI	40	
UX10IACT		40
UX10JACC	28	
UX10JOBN	C	
UX10KEY	9	
UX10LABT	3F	
UX10LBAL		40
UX10LBNL		01
UX10LBNS		04
UX10LBSL		02
UX10LDRV		0C
UX10LEN	4	
UX10LSM	07	
UX10NDRV		10
UX10NGDG		40
UX10NSEP		04
UX10PLIB		00
UX10PRSN	1C	
UX10SACC	2C	
UX10SEP		08
UX10SPID		E6
UX10STPN	14	
UX10SUBP	8	
UX10USER	24	
UX10UX10	0	
UX10VCNT	38	
UX10VLIB		80
UX10VLOC	6	
UX10VLSR	0	
UX10VNLB		40
UX10VOLL		10
UX10VOLP	34	
UX10VSCR		20
UX10XPDT	3C	

JES3 Deferred Mount User Exit (SLSUX11)

Functional Description

The JES3 Deferred Mount User Exit is invoked during JES3 Converter/Interpreter (C/I) processing to allow the user to determine whether a mount should be JES3 deferred. The exit is only invoked during static allocation. Dynamic allocation requests are deferred. Checkpoint/restart data sets used for restart are not deferred.



Note: For information on MVS deferral, refer to “Deferred Mount User Exit (SLSUX09)” on page 45.

JES3 deferral means that the volume is not mounted before step execution begins. Any mount set up by JES3 must be JES3 deferred before it can be MVS deferred.



Note: MVS deferred allocation implies JES3 deferred allocation in the JES3 environment. JES3 deferral, however, does not imply MVS deferral.

The SMC ALLOCDef command provides a DEFer option to allow or disallow JES3 deferral and take full advantage of JES3 pre-execution setup. Refer to the *Storage Management Component (SMC) Configuration and Administration Guide* for more information.

- Setting DEFer(ON) or DEFer(JEs3) automates JES3 defer processing.
 - DEFer(ON) enables deferred mount processing which overrides the JCL and defers all library mounts until the data set on the cartridge is opened. If the data set is not opened, the cartridge is not mounted. The robot is then free to perform other necessary tasks. When a volume is required, it is mounted at open time and the job waits until the cartridge is mounted before proceeding.
 - DEFer(JEs3) allows you to delay the volume mount until step execution begins.



Note: StorageTek does not recommend running with DEFer(OFF).

Environment

This user exit is applicable in JES3 environments. It is invoked by the SMC, and executes on the host where the SMC resides.

This user exit is loaded using the SMC UEXit operator command. See page 147 for more information about this command.



Note: This user exit must reside in a library accessible to the subsystem (SMC STEPLIB, JOBLIB, or your system's LINKLIB concatenation).

Conditions When Exit Routine is Executed

Entry Specifications

Upon entry to SLSUX11, register contents are as follows:

Register	Contents
0	Undefined
1	Pointer to parameter list
2-12	Undefined
13	Pointer to register save area
14	Return address
15	Entry point address

Parameter List

The parameter list is mapped by macro SLSUX11P.

Conditions on Return From User Exit

Return Specifications

On return from SLSUX11, register contents are as follows:

Register	Contents
0-14	Values at entry to exit
15	Return code (hexadecimal)

Return Codes

Table 16. SLSUX11 Return Codes

Return Code	Name	Description
0	UX11HSC	Process normally; exit does not influence JES3 defer status
4	UX11DFR	JES3 defer the mount
8	UX11NDFR	Honor the JCL defer status
64	UX11IACT	The user exit is inactive

The Main Device Scheduler (MDS) verify process is bypassed for this request.

User Exit 11 Parameter List

The parameter list is built during JES3 device separation processing. The user exit is called for a library volume allocation request. The return code from the user exit indicates the JES3 defer status of the request.

SLSUX11 Map

Offsets		Type/Value	Len	Name	Description
Dec	Hex				
0	(0)	STRUCTURE	112	SLSUX11P	User Exit 11 Parameter List
0	(0)	CHARACTER	4	UX11UX11	Eyecatcher 'UX11'
4	(4)	FULLWORD	4	UX11LEN	Length of UX11 parameter list
8	(8)	HEXSTRING	1	UX11SUBP	Storage subpool number
		'E6'		UX11SPID	Subpool 230
9	(9)	HEXSTRING	1	UX11KEY	Storage key.
10	(A)	HEXSTRING	2	*	Reserved
12	(C)	FULLWORD	4	UX11USER	Customer field; initially zero; preserved across calls
16	(10)	CHARACTER	8	UX11JOBN	Job name
24	(18)	CHARACTER	8	UX11STPN	Step name
32	(20)	CHARACTER	8	UX11PRSN	Procedure step name
40	(28)	CHARACTER	8	UX11DDN	DD name
48	(30)	CHARACTER	44	UX11DSN	Dataset name
92	(5C)	HEXSTRING	16	*	Reserved
108	(6C)	BITSTRING	1	UX11DDCH	Dataset characteristics
		1... ..		UX11SPEC	Specific volume request
		.1... ..		UX11NSPC	Nonspecific volume request
109	(6D)	HEXSTRING	3	*	Reserved
112	(70)			UX11LSTL	Length of SLSUX11P

SLSUX11 Cross Reference

Name	Hex Offset	Hex Value
SLSUX11P	0	
UX11DDCH	6C	
UX11DDN	28	
UX11DFR		04
UX11DSN	30	
UX11HSC		00
UX11IACT		40
UX11JOBN	10	
UX11KEY	9	
UX11LEN	4	
UX11LSTL		70
UX11NDFR		08
UX11NSPC		40
UX11PRSN	20	
UX11SPEC		80
UX11SPID		E6
UX11STPN	18	
UX11SUBP	8	
UX11USER	C	
UX11UX11	0	

JES3 Unit Affinity Separation User Exit (SLSUX12)

Functional Description

The JES3 Unit Affinity Separation User Exit enables you to request modification of the actions the SMC takes during allocation of a unit affinity chain or GDG ALL chain which references cartridge tape devices on a JES3 system using setup. (JES3 systems not using setup must use exit 10 to perform this function.) This exit can be used to:

- override the setting of the SMC ALLOCDef command SEPLvl parameter.
- request allocation of library drives for the chain
- request allocation of nonlibrary drives for the chain
- change the esoteric (unit name) used to allocate the chain
- request allocation of a particular ACS for the chain.

Environment

This user exit is applicable in JES3 environments. It is invoked by the SMC, and executes on the host where the SMC resides.

This user exit is invoked by the SMC for every unit affinity chain or GDG ALL chain. It is loaded using the SMC UEXit operator command. See page 147 for more information about this command.



Note: This user exit must reside in a library accessible to the subsystem (SMC STEPLIB, JOBLIB, or your system's LINKLIB concatenation).

Conditions When Exit Routine is Executed

Entry Specifications

Upon entry to SLSUX12, register contents are as follows:

Register	Contents
0	Undefined
1	Pointer to parameter list
2-12	Undefined
13	Pointer to register save area
14	Return address
15	Entry point address

Parameter List

The parameter list is mapped by macro SLSUX12P.

Conditions on Return From User Exit

Return Specifications

On return from SLSUX12, register contents are as follows:

Register	Contents
0-14	Values at entry to exit
15	Return code (hexadecimal)

Return Codes

Table 17. SLSUX12 Return Codes

Return Code	Name	Description
0	UX12HSC	Perform separation according to the SEPLvl parameter of the ALLOCDef or ALLOCJob commands
4	UX12LIB	Do not separate the chain
8	UX12NLIB	Separate the chain
12	UX12REPL	Do not separate the chain and substitute the returned esoteric
16	UX12SACS	Do not separate the chain and allocate in the specified ACS
20	UX12SEP	Separate the chain
64	UX12IACT	The user exit is inactive

Table 18. SLSUX12 Return Data in Parameter List

Name	Description
UX12ACS	ACS to allocate in if return code UX12SACS is issued.
UX12ESOT	Esoteric to substitute if return code UX12REPL is issued.

Programming Considerations

Unit affinity separation may cause the number of units which the requester needs to allocate to increase. Separation may prevent successful allocation processing if the number of units required exceeds the number available.

User Exit 12 Parameter List

The parameter list is built during device separation. The user exit is called to allow the customer to determine whether an affinity chain of DD statements should share the same unit as specified, or whether the chain should be broken. This break allows allocation of drives in the same physical location as the tape volumes required.

SLSUX12 Map

Offsets		Type/Value	Len	Name	Description
Dec	Hex				
0	(0)	STRUCTURE	76	SLSUX12P	User Exit 12 Parameter List
0	(0)	CHARACTER	4	UX12UX12	Eyecatcher 'UX12'
4	(4)	FULLWORD	4	UX12LEN	Length of UX12 parameter list
8	(8)	HEXSTRING	1	UX12SUBP	Storage subpool number
		'E6'		UX12SPID	Subpool 230
9	(9)	HEXSTRING	1	UX12KEY	Storage key.
10	(A)	HEXSTRING	2	*	Reserved
12	(C)	CHARACTER	8	UX12JOBN	Job name
20	(14)	CHARACTER	8	UX12STPN	Step name
28	(1C)	CHARACTER	8	UX12PRSN	Procedure step name
36	(24)	FULLWORD	4	UX12DCNT	Number of DDs in affinity chain
40	(28)	CHARACTER	8	UX12UNIT	JCL unit name
48	(30)	CHARACTER	8	UX12ESOT	Area to return an esoteric name
56	(38)	FULLWORD	4	UX12ACS	Area to return an ACS ID; format: 000000AA, where AA = ACS number
60	(3C)	FULLWORD	4	UX12USER	Customer field; initially zero; preserved across calls
64	(40)	CHARACTER	8	UX12MAIN	JES3 setup processor
72	(48)	BITSTRING	1	UX12AFF	Type of affinity
		1... ..		UX12GDG	GDG affinity
		.1... ..		UX12UAFF	Unit affinity
73	(49)	HEXSTRING	3	*	Reserved
76	(4C)			UX12FIXL	Length of fixed portion of parameter list

The following area immediately follows the SLSUX12P fixed data area. This area repeats once for each DD statement in the affinity chain. The number of DD statements in the affinity chain is stored in field UX12DCNT.

Offsets		Type/Value	Len	Name	Description
Dec	Hex				
0	(0)	STRUCTURE	76	SLSUX12D	User Exit 12 Dataset Parm List
0	(0)	CHARACTER	8	UX12DDN	DD name
8	(8)	CHARACTER	44	UX12DSN	Dataset name
52	(34)	FULLWORD	4	UX12NUMV	Number of volumes in dataset
56	(38)	BITSTRING	1	UX12LABT	Label type
			UX12LBDF	Library default label type
	1		UX12LBSL	Standard label
	1.		UX12LBAL	ANSI label
	11		UX12LBNL	Nonlabeled
	1..		UX12LBNS	Nonstandard label
57	(39)	HEXSTRING	1	UX12SSUB	Scratch subpool number
58	(3A)	CHARACTER	13	UX12SNAM	Scratch subpool name
71	(47)	HEXSTRING	1	*	Reserved
72	(48)	ADDRESS	4	UX12VOLP	Pointer to volume information
76	(4C)			UX12VARL	Length of dataset entry

The following area is pointed to by UX12VOLP. It consists of the volume serial and location of each volume in the data set. The number of volume entries in the list is provided by UX12NUMV.

Offsets		Type/Value	Len	Name	Description
Dec	Hex				
0	(0)	STRUCTURE	12	SLSUX12V	User Exit 12 Volume Parm List
0	(0)	CHARACTER	6	UX12VLSR	Volume serial
6	(6)	BITSTRING	1	UX12VREQ	Volume requested
		1... ..		UX12SPEC	Specific volume requested
		.1... ..		UX12NSPC	Nonspecific volume request
7	(7)	BITSTRING	1	UX12VLOC	Volume location
		1... ..		UX12VLIB	Volume resides in library
		.1... ..		UX12VNLB	Volume resides outside library
8	(8)	HEXSTRING	2	UX12AALL	If volume in library, the library location in ACS/LSM format 'AALL' (hexadecimal)
10	(A)	HEXSTRING	2	*	Reserved
12	(C)			UX12VLTL	Length of volume entry

SLSUX12 Cross Reference

Name	Hex Offset	Hex Value
SLSUX12D	0	
SLSUX12P	0	
SLSUX10V	0	
UX12AALL	8	
UX12ACS	38	
UX12AFF	48	
UX12DCNT	24	
UX12DDN	0	
UX12DSN	8	
UX12ESOT	30	
UX12FIXL		4C
UX12GDG		80
UX12HSC		00
UX12IACT		40
UX12JOBN	C	
UX12KEY	9	
UX12LABT	38	
UX12LBAL		02
UX12LBDF		00
UX12LBNL		03
UX12LBNS		04
UX12LBSL		01
UX12LEN	4	
UX12LIB		04
UX12MAIN	40	
UX12NLIB		08
UX12NSPC		40
UX12NUMV	34	
UX12PRSN	1C	
UX12REPL		0C
UX12SACS		10
UX12SEP		14
UX12SNAM	3A	
UX12SPEC		80
UX12SPID		E6
UX12SSUB	39	
UX12STPN	14	
UX12SUBP	8	
UX12USER	3C	
UX12UAFF		40
UX12UNIT	28	
UX12UX12	0	
UX12VARL		4C
UX12VLIB		80
UX12VLOC	7	
UX12VLSR	0	
UX12VLTL		0C
UX12VNLB		40
UX12VOLP	48	

SLSUX12

Name	Hex Offset	Hex Value
UX12VREQ	6	

JES3 Specific Volume Allocation User Exit (SLSUX13)

Functional Description

The JES3 Specific Volume Allocation User Exit enables the user to request modification of the actions the SMC takes during allocation of a specific volume DD statement which references cartridge tape devices on a JES3 system using setup. This exit can be used to:

- request allocation to a particular library subsystem as defined by the SMC LIBRARY command
- change esoteric (unit name) used for device allocation
- request allocation of a particular ACS
- request allocation of nonlibrary drives
- request allocation of library drives.

Environment

This user exit is applicable in JES3 environments. It is invoked by the SMC, and executes on the host where the SMC resides.

This user exit is invoked by the SMC for every DD statement that requests a specific (nonscratch) volume. It is loaded using the SMC UEXIT operator command. See page 147 for more information about this command.



Note: This user exit must reside in a library accessible to the subsystem (SMC STEPLIB, JOBLIB, or your system's LINKLIB concatenation).

Conditions when Exit Routine is Executed

Entry Specifications

Upon entry to SLSUX13, register contents are as follows:

Register	Contents
0	Undefined
1	Pointer to parameter list
2-12	Undefined
13	Pointer to register save area
14	Return address
15	Entry point address

Parameter List

The parameter list is mapped by macro SLSUX13P.

Conditions on Return From User Exit

Return Specifications

On return from SLSUX13, register contents are as follows:

Register	Contents
0-14	Values at entry to exit
15	Return code (hexadecimal)

Return Codes

Table 19. SLSUX13 Return Codes

Return Code	Name	Description
0	UX13HSC	Perform normal SMC allocation
4	UX13LIB	Select library drives
8	UX13NLIB	Select nonlibrary drives
12	UX13REPL	Replace unit name with different esoteric
16	UX13SACS	Request the allocation in the specified ACS
64	UX13IACT	The user exit is inactive

Table 20. SLSUX13 Return Data in Parameter List

Name	Description
UX13ACS	ACS to allocate in if return code UX13ASUB is issued.
UX13ESOT	Esoteric to substitute if return code UX13REPL is issued.

Programming Considerations

- Because the exit executes as an extension to the common allocation SSREQ, it cannot issue dynamic allocation requests.
- If your SMC accesses multiple libraries, you must code the UX13LIBN library name if you also code an ACS ID. The return code “Use Library Drives” is interpreted to mean use drives in any library. The return code “Use Nonlibrary Drives” is interpreted to mean use only drives not defined in any library.

User Exit 13 Parameter List

The parameter list is built by SMC during JES3 device separation. The user exit is called for a specific allocation request. The user exit provides the ability to provide allocation criteria for a given DD statement.

SLSUX13 Map

Offsets		Type/Value	Len	Name	Description
Dec	Hex				
0	(0)	STRUCTURE	168	SLSUX13P	User Exit 13 Parameter List
0	(0)	CHARACTER	4	UX13UX13	Eyecatcher 'UX13'
4	(4)	FULLWORD	4	UX13LEN	Length of UX13 parameter list
8	(8)	HEXSTRING	1	UX13SUBP	Storage subpool number
		'E6'		UX13SPID	Subpool 230
9	(9)	HEXSTRING	1	UX13KEY	Storage key.
10	(A)	HEXSTRING	2	*	Reserved
12	(C)	CHARACTER	8	UX13JOBN	Job name
20	(14)	CHARACTER	8	UX13STPN	Step name
28	(1C)	CHARACTER	8	UX13PRSN	Procedure step name
36	(24)	CHARACTER	8	UX13DDN	DD name
44	(2C)	ADDRESS	8	UX13UNIT	JCL unit name
52	(34)	CHARACTER	8	UX13ESOT	Area to return an esoteric name
60	(3C)	FULLWORD	4	UX13ACS	Area to return an ACS ID: format: 000000AA, where AA is the ACS number
64	(40)	CHARACTER	44	UX13DSN	Dataset name
108	(6C)	BITSTRING	1	UX13LABT	Label type
			UX13LBDF	Library default label type
	1		UX13LBSL	Standard label
	1.		UX13LBAL	ANSI label
	11		UX13LBNL	Nonlabeled
	1..		UX13LBNS	Nonstandard label
109	(6D)	HEXSTRING	3	*	Reserved
112	(70)	FULLWORD	4	UX13USER	Customer field; initially zero; preserved across calls
116	(74)	CHARACTER	8	UX13MAIN	JES3 setup processor
124	(7C)	FULLWORD	4	UX13NUMV	Number of volumes in dataset
128	(80)	ADDRESS	4	UX13VOLP	Address of volume information
132	(84)	BITSTRING	1	UX13FLG1	User Exit 13 flag
		1...		UX13UAFF	Element is member of unit affinity chain
		.1...		UX13GAFF	Element is member of GDGALL chain
132	(85)	HEXSTRING	3	*	Reserved
136	(88)	CHARACTER	8	UX13LIBN	Override library name
144	(90)	HEXSTRING	24	*	Reserved
168	(A8)			UX13LSTL	Length of SLSUX13P

SLSUX13

Offsets		Type/Value	Len	Name	Description
Dec	Hex				
0	(0)	STRUCTURE	9	SLSUX13V	User Exit 13 Volume Parm List
0	(0)	OFFSET	0	UX13VLST	Volume list
0	(0)	CHARACTER	6	UX13VLSR	Volume serial
6	(6)	BITSTRING	1	UX13VLOC	Volume location
		1... ..		UX13VLIB	Volume resides in library
		.1... ..		UX13VNLB	Volume resides outside library
7	(7)	HEXSTRING	2	UX13AALL	If volume in library, the library location in ACS/LSM format 'AALL' (hexadecimal)
9	(9)			UX13VLTL	Length of volume entry

SLSUX13 Cross Reference

Name	Hex Offset	Hex Value
SLSUX13P	0	
SLSUX13V	0	
UX13AALL	7	
UX13ACS	3C	
UX13DDN	24	
UX13DSN	40	
UX13ESOT	34	
UX13FLG1	84	
UX13GAFF		40
UX13HSC		00
UX13IACT		40
UX13JOBN	C	
UX13KEY	9	
UX13LABT	6C	
UX13LBAL		02
UX13LBDF		00
UX13LBNL		03
UX13LBNS		04
UX13LBSL		01
UX13LEN	4	
UX13LIB		04
UX13LIBN	88	
UX13LSTL		A8
UX13MAIN	74	
UX13NLIB		08
UX13NUMV	7C	
UX13PRSN	1C	
UX13REPL		0C
UX13SACS		10
UX13SPID		E6
UX13STPN	14	
UX13SUBP	8	
UX13UAFF		80
UX13UNIT	2C	
UX13USER	6D	
UX13UX13	0	
UX13VLIB		80
UX13VLOC	6	
UX13VLSR	0	
UX13VLST	0	
UX13VLTL		9
UX13VNLB		40
UX13VOLP	80	

Volume Access User Exit (SLSUX14)

Functional Description

The Volume Access User Exit enables you to invoke security checking for volume access at mount and eject time.

Security checking for volume access occurs when SLSUX14 is enabled and there is a request for a mount or eject of a given volume. If the volume access check is successful, no user notification occurs. If the requestor is notified, the information presented in the messages can include:

- job (for PGMI, Utilities and Job/Mount processing)
- operator request
- user-supplied data in EBCDIC.



Note: This exit is not called for:

- duplicate/unlabeled volumes being ejected by audit
- volumes being ejected by the init-cart utility
- any unlabeled volumes found in the LSM playground.

Environment

This exit has no dependencies on JES2 or JES3. It executes in the HSC address space.



Note: This user exit must reside in a library defined in the IEAAPFxx member of the SYS1.PARMLIB.

Conditions When Exit Routine is Executed

Entry Specifications

Upon entry to SLSUX14, register contents are as follows:

Register	Contents
0	Undefined
1	Pointer to parameter list
2-12	Undefined
13	Pointer to register save area
14	Return address
15	Entry point address

Parameter List

The parameter list is mapped by macro SLSUX14P.

Conditions on Return to HSC From User Exit

Return Specifications

On return from SLSUX14, register contents are as follows:

Register	Contents
0-14	Values at entry to exit
15	Return code (hexadecimal)

Return Codes

Table 21. SLSUX14 Return Codes

Return Code	Name	Description
0	UX14OK	Perform function
4	UX14NWRT	Write protect mount
8	UX14PWRD	HSC password check
12	UX14RJCT	Function reject
16	UX14RACF	HSC RACROUTE check (TAPEVOL)
20	UX14RACL	HSC RACROUTE check use UX14RCLS
64	UX14IACT	The user exit is inactive

Table 22. SLSUX14 Return Data in Parameter List

Name	Description
UX14PSWD	Blank padded password
UX14RCLS	RACF class to use for RACROUTE

Programming Considerations

You can still issue RACROUTE from within Volume Access User Exit or you can specify that HSC is to do a RACROUTE via an exit return code. You are provided with the following information:

- job name
- job request
- volume ID
- location
- issuer

The RACF user ID and group ID are provided, if they are available.

This information is extracted from the ACEE of the requestor and is sufficient to issue a RACROUTE request. If it is not available, the fields are binary zeros.



Note: For operator commands, MVS provides the information in the UTOKEN pointed to by the CIB and SSCM. However, this UTOKEN information is encrypted and is not usable.

You are provided with the following job processing-related information:

- program name
- data set name
- expiration date
- retention period.

If the information is not available, the fields are binary zeros.

You can use the information provided to affect the function in the following ways:

- allow the function to proceed
- make a mount write disabled (virtual thumbwheel)
- reject the function
- request or provide a password
- tell the HSC to issue a RACROUTE (optionally specifying the RACF class to use).

An audit trail message is issued in the event of a:

- command reject
- exit disabled (first time only)
- volume mount that is changed to write disabled via virtual thumbwheel
- password failure.

An operator prompt is generated when a password is requested. In all cases user information can be passed back to give a reason for the request or rejection.

To secure SLSUX14, the UEXIT command must also be secure. This is to ensure that SLSUX14 is not replaced by another UEXIT LOAD or disabled by UEXIT DISABLE.

SLSUX14 is dynamically loadable as long as it is in the SLSUEXIT DD data set.

SLSSYAxX Parmlib with UEXIT command

```

/* */
CDSDEF DSN1=SLS.HSC.DBASEPRM,+
        DSN2=SLS.HSC.DBASESEC,+
        DSN3=SLS.HSC.DBASESBY

JRNDEF DSN1=SLS.MVS2.JOURNAL1,+
        DSN2=SLS.MVS1.JOURNAL2,HOSTID=MVS1

JRNDEF DSN1=SLS.MVS2.JOURNAL1,+
        DSN2=SLS.MVS2.JOURNAL2,HOSTID=MVS2

SET OUTPUT MIXED

OPTION DIALOG(BOTH)

COMMPATH HOST=MVS1 METHOD=CDS
COMMPATH HOST=MVS2 METHOD=CDS

CAPPREF 1,Ø1Ø,MVS1
CAPPREF 1,Ø1Ø,MVS2

UEXIT 14 LOAD=UX14VACC

UEXIT 15 LOAD=UX15CMDS

DISPLAY ACS

DISPLAY ALLOC

DISPLAY OPTION

UEXIT (1-15) QUERY

```

Additional loads of SLSUX14 (and SLSUX15) are done dynamically through the UEXIT command if you are allowed to complete the command based on the SLSUX15 and/or security package rules.

UEXIT Command to Load an Exit

```
UEXIT 14 LOAD=UX14NEW
```

Restrictions and Limitations

Security Profile:

If SLSUX14 states that the HSC is to do security checking by returning UX14RACF or UX14RACL, the RACROUTE is issued for volume access based on job or user criteria. The following example shows a RACF TAPEVOL class profile and permission command set that would be matched against the HSC RACROUTE.

Example of RACF Profile and Permission Commands

```
*****  
* Define a profile in the TAPEVOL class for volume 111111 *  
* (No general access allowed) *  
*****  
RDEFINE TAPEVOL 111111 UACC(NONE)  
*****  
* Permit user FRED*1 to have read access to volume 111111*  
*****  
PERMIT 111111 CLASS(TAPEVOL) ID(FRED*1) ACCESS(READ)  
*****
```

A check is made for UPDATE authority. If access is allowed, the request is allowed; otherwise, a check is made for READ authority. If this is allowed, the tape is mounted write-protected. If neither UPDATE nor READ is allowed, the request is denied.



Notes:

- UPDATE authority is required to eject a volume.
- RACF 1.8.1 must be installed to have SLSUX14 perform RACF checking.

User Exit 14 Parameter List

The parameter list is built by programs that request to have a volume mounted, entered or ejected. The user exit is called to determine if and how the request should proceed.

SLSUX14 Map

Dec	Offsets		Len	Name	Description
	Hex	Type/Value			
0	(0)	STRUCTURE	256	SLSUX14P	User Exit 14 Parameter List
0	(0)	BITSTRING	1	UX14FUNC	Requested function
	1		UX14MNT	Mount
	1.		UX14EJCT	Eject
1	(1)	BITSTRING	1	UX14TYPE	Request type
			UX14UNKN	Unknown
	1		UX14HSC	HSC initiated request
	1.		UX14JOBP	Job processing request
	11		UX14UTIL	Utility request
	1..		UX14PGMI	Programmatic interface request
	1.1		UX14OPER	Operator request
	11.		UX14TMI	TMI request
		.11. ..11		UX14LSTA	Library Station request
2	(2)	BITSTRING	1	UX14STAT	Request status
		1... ..		UX14WDSB	Write disable is set
3	(3)	BITSTRING	1	UX14FLG1	Flag byte
		1... ..		UX14F1SC	Scratch request
		.1.. ..		UX14FITV	'To' device number is valid
		..1.		UX14F1FV	'From' device number is valid
4	(4)	CHARACTER	6	UX14VOLS	Volume serial
10	(A)	HEXSTRING	2	*	Reserved
12	(C)	CHARACTER	8	UX14HOST	Host ID
20	(14)	CHARACTER	13	UX14SNAM	Scratch subpool name if available
33	(21)	HEXSTRING	3	*	Reserved
36	(24)	HEXSTRING	1	UX14SSUB	Scratch subpool number
37	(25)	HEXSTRING	3	*	Reserved
40	(28)	FULLWORD	4	UX14WORD	Customer field; initially zero; preserved across calls
44	(2C)	HEXSTRING	2	UX14UNT1	'From' device number
46	(2E)	BITSTRING	1	UX14FTYP	'From' location type
	1		UX14CELL	'From' is a cell
	1.		UX14CAPC	'From' is a cap cell
	11		UX14DRIV	'From' is a drive
47	(2F)	HEXSTRING	1	UX14FACS	From ACS
48	(30)	HEXSTRING	1	UX14FLSM	From LSM
49	(31)	HEXSTRING	1	UX14FPNL	From panel
50	(32)	HEXSTRING	1	UX14FROW	From row
51	(33)	HEXSTRING	1	UX14FCOL	From column
52	(34)	HEXSTRING	1	UX14FCAP	From cap
53	(35)	HEXSTRING	3	*	Reserved
56	(38)	HEXSTRING	2	UX14UNT2	'To' unit
58	(3A)	HEXSTRING	1	UX14TTYP	'To' location type

SLSUX14

Offsets		Type/Value	Len	Name	Description
Dec	Hex				
59	(3B)	HEXSTRING	1	UX14TACS	To ACS
60	(3C)	HEXSTRING	1	UX14TLSM	To LSM
61	(3D)	HEXSTRING	1	UX14TPNL	To panel
62	(3E)	HEXSTRING	1	UX14TROW	To row
63	(3F)	HEXSTRING	1	UX14TCOL	To column
64	(40)	HEXSTRING	1	UX14TCAP	To cap
65	(41)	HEXSTRING	3	*	Reserved
68	(44)	CHARACTER	8	UX14RUSR	RACF user ID
76	(4C)	CHARACTER	8	UX14RGRP	RACF group
84	(54)	HEXSTRING	4	*	Reserved
88	(58)	HEXSTRING	4	UX14CONS	Console ID
92	(5C)	CHARACTER	8	UX14CNAM	Console name
100	(64)	CHARACTER	8	UX14USID	User ID
108	(6C)	HEXSTRING	4	*	Reserved

The following fields are for job processing requests.

112	(70)	CHARACTER	8	UX14JOBN	Job name
120	(78)	CHARACTER	8	UX14STEP	Step name
128	(80)	CHARACTER	8	UX14PGNM	Program name
136	(88)	CHARACTER	44	UX14DSN	Dataset name
180	(B4)	HEXSTRING	3	UX14EXPD	Expiration date
183	(B7)	HEXSTRING	2	UX14RETN	Retention period
185	(B9)	HEXSTRING	11	*	Reserved

The following fields can be returned by the exit.

196	(C4)	CHARACTER	8	UX14PSWD	Password, padded with blanks
204	(CC)	CHARACTER	9	UX14RCLS	RACF class to use for RACROUTE: 1 byte length followed by class name
213	(D5)	CHARACTER	32	UX14UMSG	User information
248	(F8)	HEXSTRING	8	*	Reserved
256	(100)			UX14L	Length of SLSUX14P

SLSUX14 Cross Reference

Name	Hex Offset	Hex Value
SLSUX14P	0	
UX14CAPC		02
UX14CELL		01
UX14CNAM	5C	
UX14CONS	58	
UX14DRIV		03
UX14DSN	88	
UX14EJCT		02
UX14EXPD	B4	
UX14FACS	2F	
UX14FCAP	34	
UX14FCOL	33	
UX14FLG1	3	
UX14FLSM	30	
UX14FPNL	31	
UX14FROW	32	
UX14FTYP	2E	
UX14FUNC	0	
UX14F1FV		20
UX14F1SC		80
UX14FITV		40
UX14HOST	C	
UX14HSC		01
UX14IACT		40
UX14JOBP		02
UX14JOBN	70	
UX14LSTA		63
UX14MNT		01
UX14NWRT		04
UX14OK		00
UX14OPER		05
UX14PGMI		04
UX14PGMN	80	
UX14PSWD	C4	
UX14PWRD		08
UX14RACF		10
UX14RACL		14
UX14RCLS	CC	
UX14RETN	B7	
UX14RGRP	4C	
UX14RJCT		0C
UX14RUSR	44	
UX14SNAM	14	
UX14SSUB	24	
UX14STAT	2	
UX14STEP	78	
UX14TACS	3B	
UX14TCAP	40	
UX14TCOL	3F	

SLSUX14

Name	Hex Offset	Hex Value
UX14TLSM	3C	
UX14TMI		06
UX14TPNL	3D	
UX14TROW	3E	
UX14TTYP	3A	
UX14TYPE	1	
UX14UMSG	D5	
UX14UNKN		00
UX14UNT1	2C	
UX14UNT2	38	
UX14USID	64	
UX14UTIL		03
UX14VOLS	4	
UX14WDSB		80
UX14WORD	28	

Command Authorization User Exit (SLSUX15)

Functional Description

The Command Authorization User Exit is used to ensure command security. A tier level presentation is used with the actual command string. Information to issue CMDAUTH from the exit is provided. This information includes:

- User
- Request
- Console
- Command
- Command string
- Command tier level: minimum to maximum
 1. Query
 2. Update
 3. Control
- CIB address or SSCM address
- RACF UTOKEN

This information is used to:

- permit the use of the command
- supply and request a password
- reject the command
- request that HSC process CMDAUTH for the command.

You can use the default values that the HSC provides or the security matrix within the table together with the command string. The following table shows the minimum generic security levels.

Table 23. Command Security Level

Command	Minimum Level
ALLOC	Update
CAPPREF	Update
CDS	Control
CLEAN	Control
COMMPATH	Update
DIAG	Query
DISMOUNT	Control
DISPLAY	Query
DRAIN	Control
EJECT	Control

Table 23. Command Security Level (Continued)

Command	Minimum Level
ENTER	Control
F	Control
JOURNAL	Update
LIST	Query
LOAD	Query
LS	Query
MN	Update
MNTD	Update
MODIFY	Control
MONITOR	Update
MOUNT	Control
MOVE	Control
OPTION	Update
PM	Update
RECOVER	Control
RELEASE	Control
RETRY	Control
SENDER	Control
SRVLEV	Control
STOPMN	Update
SWITCH	Control
TRACE	Query
UEXIT	Update
UNITDEF	Update
VARY	Control
VIEW	Update
VOLDEF	Update
WARN	Update

Environment

This exit has no dependencies on JES2 or JES3. It executes in the HSC address space.



Note: This user exit must reside in a library defined in the IEAAPFxx member of the SYS1.PARMLIB.

Conditions When Exit Routine is Executed

Entry Specifications

Upon entry to SLSUX15, register contents are as follows:

Register	Contents
0	Undefined
1	Pointer to parameter list
2-12	Undefined
13	Pointer to register save area
14	Return address
15	Entry point address

Parameter List

The parameter list is mapped by macro SLSUX15P.

Execution Attributes

Shared enqueues held on major name SYSIEFSD, minor names Q4, CHNGDEVS, DDRTPUT, and DDRDA.

Conditions on Return To HSC From User Exit

Return Specifications

On return from SLSUX15, register contents are as follows:

Register	Contents
0-14	Values at entry to exit
15	Return code (hexadecimal)

Return Codes

Table 24. SLSUX15 Return Codes

Return Code	Name	Description
0	UX15OK	Perform function
4	UX15PWRD	Check password through HSC
8	UX15RJCT	Function reject
12	UX15CHKA	Check authority through CMDAUTH
64	UX15IACT	The user exit is inactive

Table 25. SLSUX15 Return Data in Parameter List

Name	Description
UX15PSWD	Blank padded user password
UX15UDTA	User information

Programming Considerations

You can use the HSC default values provided for each command or define a new security matrix within a table you create and use in conjunction with the command string provided in SLSUX15. Parsing the command string past the first operand (the command) is your responsibility.

An audit trail is issued in the event of a rejected command, disabled exit, or password failure. An operator prompt is issued when a password is requested. Once the password is received, it is made unreadable. The operator's response is also made unreadable and compared with the encrypted password from the exit. After the compare, both are erased.



Note: The Command Authorization User Exit does not include control statements executed during HSC PARMLIB read or any HSC utilities. Security for PARMLIB access and utility jobs must be defined through your security packages.

The HSC programmatic interface (PGMI) is not controlled through SLSUX15 because it can be controlled through SLSUX05.

SLSUX15 is dynamically loadable as long as it is in the SLSUEXIT DD data set.

SLSSYAx Parmlib with UEXIT command

```

/* */
CDSDEF DSN1=SLS.HSC.DBASEPRM,+
       DSN2=SLS.HSC.DBASESEC,+
       DSN3=SLS.HSC.DBASESBY

JRNDDEF DSN1=SLS.MVS2.JOURNAL1,+
        DSN2=SLS.MVS1.JOURNAL2,HOSTID=MVS1

JRNDDEF DSN1=SLS.MVS2.JOURNAL1,+
        DSN2=SLS.MVS2.JOURNAL2,HOSTID=MVS2

OPTION OUTPUT(MIXED)

OPTION DIALOG(BOTH)

COMMPATH HOST=MVS1 METHOD=CDS
COMMPATH HOST=MVS2 METHOD=CDS

CAPPREF 1,Ø1Ø,MVS1
CAPPREF 1,Ø1Ø,MVS2

UEXIT 15 LOAD=UX15VACC

UEXIT 15 LOAD=UX15CMDS

DISPLAY ACS

DISPLAY ALLOC

DISPLAY OPTION

UEXIT (1-15) QUERY

```

Additional loads of SLSUX15 are done dynamically through the UEXIT command if you are allowed to complete the command based on the SLSUX15 and/or security package rules.

UEXIT Command to Load an Exit

```
UEXIT 15 LOAD=UX15NEW
```

Restrictions and Limitations

Security Profile:

If SLSUX15 sets a return code of UX15CHKA, a CMDAUTH is issued for command authorization based on user criteria. The following example shows a RACF OPERCMDS class profile and permission command set that would be matched against the HSC CMDAUTH.

Example of RACF Profile and Permission Commands

```
*****  
*           Define a profile in the OPERCMDS class for Mount command      *  
*           (No general access allowed)                                   *  
*****  
RDEFINE OPERCMDS_ subsysname.MOUNT.* UACC(NONE)  
*****  
*           Permit user FREDØ1 to have read access to volume 111111      *  
*****  
PERMIT subsysname.MOUNT.* CLASS(OPERCMDS) ID(FREDØ1) ACCESS(UPDATE)  
*****
```

User Exit 15 Parameter List

The parameter list is built and provides users with the capability to check command authority with whatever security mechanisms are currently in place. When control is returned to the request processor routine, action will be taken based on the return code set in register 15.

SLSUX15 Map

Offsets		Type/Value	Len	Name	Description
Dec	Hex				
0	(0)	STRUCTURE	520	SLSUX15P	User Exit 15 Parameter List
0	(0)	CHARACTER	8	UX15CMND	Command being processed
8	(8)	FULLWORD	4	UX15WORD	Customer field; initially zero; preserved across calls
12	(C)	HEXSTRING	4	UX15UTOK	Security user token
16	(10)	BITSTRING	1	UX15TIER	Security tier level
	1.		UX15READ	Query (read)
	1..		UX15UPDT	Policy setting (update)
	11.		UX15CNTL	All functions (control)
17	(11)	BITSTRING	1	UX15TYPE	Type of request
	1		UX15CMD	Command
18	(12)	HEXSTRING	34	*	Reserved
52	(34)	CHARACTER	4	UX15SSYS	Subsystem name
56	(38)	ADDRESS	4	UX15CIB	Pointer to CIB
60	(3C)	ADDRESS	4	UX15SSCM	Pointer to SSCB
64	(40)	HEXSTRING	4	UX15CONS	Console ID
68	(44)	HEXSTRING	8	UX15CART	Cart token
76	(4C)	CHARACTER	8	UX15CNAM	Console name
84	(54)	CHARACTER	8	UX15USID	User ID
92	(5C)	CHARACTER	256	UX15STRG	Command string
348	(15C)	HEXSTRING	1	UX15PRFX	Command prefix
349	(15D)	HEXSTRING	99	*	Reserved
448	(1C0)	CHARACTER	8	UX15PSWD	Password, padded with blanks
456	(1C8)	CHARACTER	32	UX15UDTA	User information
488	(1E8)	HEXSTRING	32	*	Reserved
520	(208)			UX15L	Length of SLSUX15P

SLSUX15 Cross Reference

Name	Hex Offset	Hex Value
SLSUX15P	0	
UX15CART	44	
UX15CHKA		0C
UX15CIB	38	
UX15CMD		01
UX15CMND	0	
UX15CNAM	4C	
UX15CNTL		06
UX15CONS	40	
UX15IACT		40
UX15OK		00
UX15PRFX	15C	
UX15PSWD	1C0	
UX15PWRD		04
UX15READ		02
UX15RJCT		08
UX15SSCM	3C	
UX15SSYS	34	
UX15STRG	5C	
UX15TIER	10	
UX15TYPE	11	
UX15UDTA	1C8	
UX15UPDT		04
UX15USID	54	
UX15UTOK	C	
UX15WORD	8	

Chapter 3. MVS/CSC Format User Exits

Overview

The following table lists the MVS/CSC format user exits included with NCS 6.1 and describes the primary function of each exit.



Note: Shaded columns indicate user exits now invoked and managed by the SMC. These user exits affect client allocation and message handling functions.

Table 26. MVS/CSC Format User Exits

Exit	Name	Description	Function
1	SCSUX01	Message Handling User Exit	Facilitates interface of the MVS/CSC to tape management systems. It is also used to implement scratch subpooling.
2	SCSUX02	JES2 Scratch Allocation User Exit	Used to influence allocation and selection of tape drives to satisfy a nonspecific volume request under JES2.
4	SCSUX04	JES3 Scratch Allocation User Exit	Used to influence allocation and selection of tape drives to satisfy a nonspecific volume request under JES3.
5	SCSUX05	Programmatic Interface Authorization User Exit	Used to perform authorization checking of PGMI requesting programs.
8	SCSUX08	JES2 Specific Volume Allocation User Exit	Used to influence allocation and selection of tape drives to satisfy a specific volume request under JES2.
9	SCSUX09	Deferred Mount User Exit	Allows you to override the default setting and MVS defer the mount of a cartridge on a library drive.
10	SCSUX10	JES2 Unit Affinity Separation User Exit	Allows you to override the default setting, and control GDG or unit affinity separation for a specific GDG ALL or unit affinity chain.
11	SCSUX11	JES3 Deferred Mount User Exit	Allows you to override the default setting and JES3 defer the mount of a cartridge on a library drive.
12	SCSUX12	JES3 Unit Affinity Separation User Exit	Allows you to override the default setting, and control GDG or unit affinity separation for a specific GDG ALL or unit affinity chain.
13	SCSUX13	JES3 Specific Volume Allocation User Exit	Used to influence allocation and selection of tape drives to satisfy a specific volume request under JES3.

Sample user exits are distributed as follows:

- SMC managed JES2 user exits and the message handling user exit are distributed in the SMC JES2 SAMPLIB (UXnnHSCn).
- SMC managed JES3 user exits are distributed in the SMC JES3 SAMPLIB (UXnnHSCn).
- MVS/CSC managed user exit samples (UXnnCSCn) are distributed in the MVS/CSC SAMPLIB.

MVS/CSC User Exits in JES Environments

The following table provides a reference for determining the applicability of any user exit function within a JES environment.

Table 27. MVS/CSC User Exits in JES Environments

User Exit Function	JES2	JES3
Deferred Mount	SCSUX09	SCSUX09 SCSUX11
Influence Device Allocation for Scratch Volume Requests	SCSUX02	SCSUX04
Influence Device Allocation for Specific Volume Requests	SCSUX08	SCSUX13
Esoteric Substitution or Unit Affinity Separation for Affinity Chains	SCSUX10	SCSUX12



Note: All other user exits are applicable regardless of the JES running.

MVS/CSC User Exits and Scratch Subpooling

Tape management systems such as CA-1 (TMS), CA-DYNAM/TLMS, DFSMSrmm, and Zara allow definition of relationships between job names or data set names and tape or cartridge volume serial numbers. This concept is sometimes referred to as scratch subpooling. When it is employed, the tape management system only allows certain nonspecific (scratch) mounts to be satisfied by volumes in qualified scratch subpools.

Scratch subpooling is facilitated by using MVS/CSC user exits in conjunction with the definitions of scratch subpools in the tape management system and the Library Control System (LCS).

- User Exits SCSUX01 and SCSUX02/SCSUX04 are used to implement scratch subpooling.
- SCSUX01 is called at volume mount time to select a scratch volume. The subpool information provided by SCSUX01 allows the selection of a tape volume from the correct subpool.
- SCSUX02/SCSUX04 is called at device allocation time to select a scratch volume of the correct subpool type. The subpool information provided by SCSUX02/SCSUX04 allows the selection of a tape drive in the LSM with the most scratch volumes of the correct subpool type.

Message Handling User Exit (SCSUX01)

Functional Description

This exit is provided to allow installations with tape management systems other than CA-1 (TMS), CA-DYNAM/TLMS, DFSMSrmm, or Zara to interface with the SMC. Each installation should examine all WTOs and WTORs issued by their tape management system and, if action is required, direct the subsystem to perform the necessary operation by setting values in the parameter list passed to it.

Use this exit to perform automated mounts of scratch cartridges from different scratch subpools or of label types other than the library scratch label type. You can also use this exit to automate responses to WTOR-type messages.

This exit is invoked for every WTO or WTOR issued in the MVS host system. The exit should evaluate the message and, if owned by the exit, fill in the appropriate fields in the parameter list.

Environment

This user exit is applicable in both JES2 and JES3 environments. It is invoked by the SMC, and executes on the host where the SMC resides.

This user exit is invoked by the SMC for every WTO or WTOR intercepted by the SMC. It is loaded using the SMC UEXit operator command. See “SMC UEXit command” on page 147 for more information about this command.



Note: This user exit must reside in a library accessible to the subsystem (SMC STEPLIB, JOBLIB, or your system's LINKLIB concatenation).

Conditions when User Exit Routine is Executed

Parameter List

The parameter list is mapped by macro SCSUX01P.

Entry Specifications

Upon entry to SCSUX01, register contents are as follows:

Register	Contents
0	Undefined
1	Pointer to parameter list
2-12	Undefined
13	Pointer to register save area
14	Return address
15	Entry point address

Conditions on Return from User Exit

Return Specifications

On return from SCSUX01, register contents are as follows:

Register	Contents
0-14	Values at entry to exit
15	Return code (hexadecimal)

Return Codes

Table 28. SCSUX01 Return Codes

Return Code	Name	Description
0	UX01CSC	The SMC interprets the message
4	UX01ACTN	The message is interpreted by the user exit. The SMC follows user exit direction.
64	UX01NOPR	The user exit is inactive. The message is interpreted by the SMC.

Programming Considerations

- The exit routine should examine each message, set the operation to be performed in UX01FUNC, and fill in the appropriate fields that apply to the function.
- In a multiple library environment, only one copy of SCSUX01 is invoked.

Examples**Mount Nonspecific Volume**

In the following example, the user exit is set to mount a nonspecific volume of the library label type.

```
set UX01FUNC to C'1'.
set UX01VOLS to 'SCRATCH' or 'PRIVAT'.
set UX01FUNT to drive address.
set UX01SSUB TO ZERO
set UX01LABT to UX01DFLT.
```

Mount Nonspecific Volume from Scratch Subpool

In the following example, the user exit is set to mount a nonspecific scratch volume from a scratch subpool of the library label type.

```
set UX01FUNC to C'1'.
set UX01VOLS to 'SCRATCH' or 'PRIVAT'.
set UX01FUNT to drive address.
set UX01SSUB to subpool index.
set UX01LABT to UX01DFLT.
```

Mount Nonspecific Volume from Scratch Subpool

In the following example, the user exit is set to mount a nonspecific scratch volume from the scratch subpool of a label type different than the library label type.

```
set UX01FUNC to C'1'.
set UX01VOLS to 'SCRATCH' or 'PRIVAT'.
set UX01FUNT to drive address.
set UX01SSUB to subpool index.
set UX01LABT to label type.
```

Mount Specific Volume

In the following example, the user exit is set to mount a specific volume.

```
set UX01FUNC to C'1'.
set UX01VOLS to appropriate VOLSER for specific request..
set UX01FUNT to drive address.
set UX01LABT to label type.
```

Dismount Volume

In the following example, the user exit is set to dismount a volume.

```
set UX01FUNC to C'2'.
set UX01FUNT to drive address.
set UX01DISP to disposition.
```

Swap Volume

In the following example, the user exit is set to swap a volume. Swap processing occurs only in JES2 environments.

```
set UX01FUNC to C'3'.
set UX01FUNT to FROM drive address.
set UX01TUNT to TO drive address.
```

Operator Intervention

In the following example, the user exit is set to allow for operator intervention.

```
set UX01FUNC to C'5'.
set UX01OPIN to UX01ON.
set UX01VOLS to cartridge serial number.
set UX01FUNT to FROM drive address.
set UX01TUNT to TO drive address.
set UX01LABT to label type.
```

User Exit 01 Parameter List

The parameter list is built by the NCS message intercept program prior to invoking the user exit. It contains the address of the WQE (the MVS Write Queue Element) containing a message. The user exit can inspect the message and request specific actions by setting the appropriate values and the return code to UX01ACTN.

SCSUX01 Map

Offsets		Type/Value	Len	Name	Description
Dec	Hex				
0	(0)	STRUCTURE	48	SCSUX01P	User Exit 01 Parameter List
0	(0)	ADDRESS	4	UX01WQE	Address of MVS WQE
4	(4)	ADDRESS	4	UX01USER	Address of USERDATA parameter value
8	(8)	FULLWORD	4	UX01ULEN	Length of USERDATA parameter value
12	(C)	CHARACTER	1	UX01FUNC	Function code
		'1'		UX01MNT	Mount a cartridge.
		'2'		UX01DMNT	Dismount a cartridge.
		'3'		UX01SWAP	Swap a cartridge from XXX to YYY.
		'5'		UX01NOP	No operation to be performed.
13	(D)	BITSTRING	1	UX01OPIN	Operator intervention flag
		...1....		UX01ON	Operator intervention requested.
14	(E)	CHARACTER	6	UX01VOLS	Volume serial number of cartridge
20	(14)	HEXSTRING	10	*	Reserved
30	(1E)	CHARACTER	1	UX01DISP	Disposition of volume
		'K'		UX01KEEP	Keep volume.
		'D'		UX01DELT	Delete volume.
31	(1F)	BITSTRING	1	UX01LABT	Label type
			UX01DFLT	Library default label type
	1		UX01SL	Standard label
	1.		UX01AL	ANSI label
	11		UX01NL	Nonlabeled
	1..		UX01NSL	Nonstandard label
32	(20)	CHARACTER	4	UX01FUNT	Mount/Dismount/Swap "from" unit address
36	(24)	CHARACTER	4	UX01TUNT	"To" unit address
40	(28)	HEXSTRING	1	UX01SSUB	Scratch subpool number
41	(29)	HEXSTRING	7	*	Reserved
48	(30)			UX01L	Length of SCSUX01P

SCSUX01 Cross Reference

Name	Hex Offset	Hex Value
SCSUX01P	0	
UX01ACTN		04
UX01AL		02
UX01CSC		00
UX01DELT		C4
UX01DFLT		00
UX01DISP	1E	
UX01DMNT		F2
UX01FUNC	C	
UX01FUNT	20	
UX01HSC		00
UX01KEEP		D2
UX01L		3C
UX01LABT	1F	
UX01MNT		F1
UX01NL		03
UX01NOP		F5
UX01NOPR		40
UX01NSL		04
UX01ON		16
UX01OPIN	D	
UX01SL		01
UX01SSUB	28	
UX01SWAP		F3
UX01TUNT	24	
UX01USER	4	
UX01ULEN	8	
UX01VOLS	E	
UX01WQE	0	

JES2 Scratch Allocation User Exit (SCSUX02)

Functional Description

The scratch allocation user exit (SCSUX02) allows you to specify values that influence device allocation based on installation-dependent criteria. SMC allocation invokes SCSUX02 providing it with the job name, data set name, DD name, step name, procedure step name, address of job accounting information, address of step accounting information, and the text specified in the USERdata startup parameter. In a multiple library environment, SCSUX02 is invoked only one time.

Environment

This user exit is applicable in JES2 environments. It is invoked by the SMC, and executes on the host where the SMC resides.

This user exit is invoked by the SMC for every unit affinity chain or GDG ALL chain that requires allocation. It is loaded using the SMC UEXit operator command. See “SMC UEXit command” on page 147 for more information about this command.



Note: This user exit must reside in a library accessible to the subsystem (SMC STEPLIB, JOBLIB, or your system's LINKLIB concatenation).

Conditions when User Exit Routine is Executed

Parameter List

The parameter list is mapped by macro SCSUX02P.

Entry Specifications

Upon entry to SCSUX02, register contents are as follows:

Register	Contents
0	Undefined
1	Pointer to parameter list
2-12	Undefined
13	Pointer to register save area
14	Return address
15	Entry point address

Conditions on Return from User Exit

Return Specifications

On return from SCSUX02, register contents are as follows:

Register	Contents
0-14	Values at entry to exit
15	Return code (hexadecimal)

Return Codes

Table 29. SCSUX02 Return Codes

Return Code	Name	Description
0	UX02CSC	No user technique specified
4	UX02LIB	Request eligible drives based on the server device list returned during drive exclusion
8	UX02NLIB	Request nonlibrary drives to satisfy allocation request
12	UX02LIBP	Either library or nonlibrary drives can be used to satisfy allocation request; library transports are preferred
16	UX02ESUB	Request esoteric substitution
20	UX02NSUB	Direct allocation of drives to a specific ACS or MVS/CSC subsystem
32	UX02VIRT	Select a virtual drive.
64	UX02IACT	The user exit is inactive

When the user specifies the first or third scratch technique (return code 4 or 12), a scratch subpool index and label type or a specified MVS/CSC subsystem name (for multiple MVS/CSC subsystems) may also be returned to permit drive prioritization to prefer the drives in the LSM with the greatest number of scratch volumes of that subpool and label type and of a particular MVS/CSC.

When the user specifies the fifth scratch technique (return code 20), a specific MVS/CSC subsystem name must be supplied and an ACS ID might optionally be returned. If a nonzero ACS ID is not returned, ACS0 is assumed.

Programming Considerations

A scratch subpool (UX02SSUB) value of X'00' is designated to be the “default” subpool. If SCSUX02 returns a UX02SSUB value of X'00', it **must** also return the “default” label type (UX02LBDF=X'00'). Likewise, the default label type is UX02LBDF and it must return the default subpool (UX02SSUB=X'00').

Examples

In the following example, the user exit instructs the SMC to direct the allocation for a scratch request to nonlibrary devices.

```
set Register 15 to 8.
```

In the following example, the user exit instructs the SMC to direct the allocation to the library drives controlled by MVS/CSC subsystem CSC1. The devices in the LSM with the most standard-labeled scratch volumes of subpool 2 should be preferred.

```
set Register 15 to 20.  
set UX02CSCN to 'CSC1'.  
set UX02ACS to 1.  
set UX02SSUB to 2.  
set UX02LABT to UX02LBSL.
```

User Exit 02 Parameter List

The parameter list is built for a nonspecific allocation request. The return code from the user exit indicates the technique which SMC allocation should use for the unit selection(s). When the allocation technique indicates a library drive, the user exit can qualify the selection by a scratch subpool, or a scratch subpool and label type.

SCSUX02 Map

Offsets		Type/Value	Len	Name	Description
Dec	Hex				
0	(0)	STRUCTURE	144	SCSUX02P	User Exit 02 Parameter List
0	(0)	CHARACTER	4	UX02UX02	Eyecatcher 'UX02'
4	(4)	FULLWORD	4	UX02LEN	Length of UX02 parameter list
8	(8)	HEXSTRING	1	UX02SUBP	Storage subpool number
		'E6'		UX02SPID	Subpool 230
9	(9)	HEXSTRING	1	UX02KEY	Storage key.
10	(A)	HEXSTRING	2	*	Reserved
12	(C)	CHARACTER	8	UX02JOBN	Job name
20	(14)	CHARACTER	8	UX02STPN	Step name
28	(1C)	CHARACTER	8	UX02PRSN	Procedure step name
36	(24)	CHARACTER	8	UX02DDN	DD name
44	(2C)	ADDRESS	4	UX02USER	Address of USERDATA parameter value
48	(30)	FULLWORD	4	UX02ULEN	Length of USERDATA parameter value
52	(34)	ADDRESS	4	UX02JACC	Address of job accounting information
56	(38)	ADDRESS	4	UX02SACC	Address of step accounting information
60	(3C)	CHARACTER	44	UX02DSN	Dataset name
104	(68)	HEXSTRING	1	UX02SSUB	Scratch subpool
105	(69)	BITSTRING	1	UX02LABT	Label type
			UX02LBDF	Library default label type
	1		UX02LBSL	Standard label
	1 .		UX02LBAL	ANSI label
	11		UX02LBNL	Nonlabeled
	1 ..		UX02LBNS	Nonstandard label
106	(6A)	CHARACTER	3	UX02XPDT	Dataset expiration date from JFCB
109	(6D)	HEXSTRING	3	*	Reserved
112	(70)	CHARACTER	8	UX02ESO	Area to return an esoteric name
120	(78)	CHARACTER	4	UX02CSCN	MVS/CSC subsystem to process request
124	(7C)	HEXSTRING	1	UX02ACS	Area to return an ACS ID
125	(7D)	CHARACTER	13	UX02SNAM	Scratch subpool name
140	(8C)	ADDRESS	4	UX02JFCB	Address of the JFCB
144	(90)			UX02LSTL	Length of SCSUX02P

SCSUX02 Cross Reference

Name	Hex Offset	Hex Value
SCSUX02P	0	
UX02ACS	7C	
UX02CSC		00
UX02CSCN	78	
UX02DDN	24	
UX02DSN	3C	
UX02ESO	70	
UX02ESUB		10
UX02IACT		40
UX02JACC	34	
UX02JFCB	8C	
UX02JOBN	C	
UX02KEY	9	
UX02LABT	69	
UX02LBAL		02
UX02LBDF		00
UX02LBNL		03
UX02LBNS		04
UX02LBSL		01
UX02LEN	4	
UX02LIB		04
UX02LIBP		0C
UX02LSMP	88	
UX02LSNO		00
UX02NLIB		08
UX02NSUB		14
UX02PRSN	1C	
UX02SACC	34	
UX02SNAM	7D	
UX02SPID		E6
UX02SSUB	68	
UX02STPN	14	
UX02SUBP	8	
UX02ULEN	30	
UX02USER	2C	
UX02UX02	0	
UX02VIRT		20
UX02XPDT	6A	

JES3 Scratch Allocation User Exit (SCSUX04)

Functional Description

The scratch allocation user exit (SCSUX04) allows you to specify values that influence device allocation based on installation-dependent criteria. SMC allocation invokes SCSUX04 providing it with the job name, data set name, DD name, step name, procedure step name, and the text specified in the USERdata startup parameter.

In a multiple MVS/CSC subsystem environment, SCSUX04 is invoked only one time. SCSUX04 is applicable in JES3 during the POSTSCAN phase of the converter/interpreter scheduling element, the JES3 main device scheduler (MDS) function, and dynamic allocation.

Environment

This user exit is applicable in JES3 environments. It is invoked by the SMC, and executes on the host where the SMC resides.

This user exit is loaded using the SMC UEXit operator command. See “SMC UEXit command” on page 147 for more information about this command.



Note: This user exit must reside in a library accessible to the subsystem (SMC STEPLIB, JOBLIB, or you system’s LINKLIB concatenation).

Conditions when User Exit Routine is Executed

Parameter List

The parameter list is mapped by macro SCSUX04P.

Entry Specifications

Upon entry to SCSUX04, register contents are as follows:

Register	Contents
0	Undefined
1	Pointer to parameter list
2-12	Undefined
13	Pointer to register save area
14	Return address
15	Entry point address

Conditions on Return from User Exit

Return Specifications

On return from SCSUX04, register contents are as follows:

Register	Contents
0-14	Values at entry to exit
15	Return code (hexadecimal)

Return Codes

Table 30. SCSUX04 Return Codes

Return Code	Name	Description
0	UX04CSC	No user technique specified
4	UX04LIB	MVS/CSC influences JES3 device allocation to select eligible library drives based on the server device list returned during drive exclusion.
8	UX04NLIB	Request nonlibrary drives to satisfy allocation request
12	UX04REPL	Request esoteric substitution
16	UX04NSUB	Direct allocation of drives to a specific ACS or MVS/CSC subsystem
24	UX04VIRT	Select a virtual drive.
64	UX04IACT	The user exit is inactive

Programming Considerations

A scratch subpool (UX04SSUB) value of X'00' is designated to be the "default" subpool. If SCSUX04 returns a UX04SSUB value of X'00', it **must** also return the "default" label type (UX04LBDF=X'00'). Likewise, the default label type is UX04LBDF and it must return the default subpool (UX04SSUB=X'00').

Examples

In the following example, the user exit instructs the SMC to direct the allocation for a scratch request to nonlibrary devices.

```
set Register 15 to 8.
```

In the following example, the user exit instructs the SMC to direct the allocation to the library drives controlled by MVS/CSC subsystem CSC1. The devices in the LSM with the most standard-labeled scratch volumes of subpool 2 should be preferred.

```
set Register 15 to 16.  
set UX04CSCN to 'CSC1'.  
set UX04ACS to 1.  
set UX04SSUB to 2.  
set UX04LABT to UX04LBSL.
```

User Exit 04 Parameter List

The parameter list is built during drive exclusion and during drive prioritization. The user exit is called when a nonspecific allocation request occurs during drive exclusion for normal or dynamic allocation (UX04CFLG = 0). The user exit is also called when a nonspecific allocation request occurs during drive prioritization processing (UX04CFLG = UX04DIRA).

SCSUX04 Map

Offset		Type/Value	Len	Name	Description
Dec	Hex				
0	(0)	STRUCTURE	168	SCSUX04P	User Exit 04 Parameter List
0	(0)	CHARACTER	4	UX04UX04	Eyecatcher 'UX04'
4	(4)	FULLWORD	4	UX04LEN	Length of UX04 parameter list
8	(8)	HEXSTRING	1	UX04SUBP	Storage subpool number
		'E6'		UX04SPID	Subpool 230
9	(9)	HEXSTRING	1	UX04KEY	Storage key.
10	(A)	HEXSTRING	1	UX04CFLG	UX04 call flag
		1... ..		UX04DIRA	Called during JES3 directed allocation
			UX04CI	Called during JES3 converter/interpreter
11	(B)	HEXSTRING	1	UX04FLAG	UX04 general flag used only when called from converter/interpreter
		1... ..		UX04UAFF	Element is member of unit affinity chain
		.1... ..		UX04GAFF	Element is member of a GDGALL group
12	(C)	CHARACTER	8	UX04JOBN	Job name
20	(14)	CHARACTER	8	UX04STPN	Step name
28	(1C)	CHARACTER	8	UX04PRSN	Procedure step name
36	(24)	CHARACTER	8	UX04DDN	DD name
44	(2C)	ADDRESS	4	UX04USER	Address of USERDATA parameter value
48	(30)	FULLWORD	4	UX04ULEN	Length of USERDATA parameter value
52	(34)	CHARACTER	44	UX04DSN	Dataset name
96	(60)	HEXSTRING	1	UX04SSUB	Scratch subpool
97	(61)	BITSTRING	1	UX04LABT	Label type
			UX04LBDF	Library default label type
	1		UX04LBSL	Standard label
	1.		UX04LBAL	ANSI label
	11		UX04LBNL	Nonlabeled
	1..		UX04LBNS	Nonstandard label
98	(62)	CHARACTER	8	UX04MAIN	JES3 setup processor
106	(6A)	CHARACTER	8	UX04UNIT	JCL unit name
114	(72)	CHARACTER	8	UX04ESOT	Area to return an esoteric name
122	(7A)	CHARACTER	4	UX04CSCN	MVS/CSC subsystem to process request
128	(80)	FULLWORD	4	UX04ACS	Area to return an ACS ID; format: 000000AA, where AA is the ACS number
132	(84)	HEXSTRING	36	*	Reserved
168	(A8)			UX04LSTL	Length of SCSUX04P

SCSUX04 Cross Reference

Name	Hex Offset	Hex Value
SCSUX04P	0	
UX04ACS	80	
UX04CFLG	A	
UX04CI		00
UX04CSC		00
UX04CSCN	7A	
UX04DIRA		80
UX04DDN	24	
UX04DSN	34	
UX04ESOT	72	
UX04FLAG	B	
UX04GAFF		40
UX04IACT		40
UX04JOBN	C	
UX04KEY	9	
UX04LABT	61	
UX04LBAL		02
UX04LBDF		00
UX04LBNL		03
UX04LBNS		04
UX04LBSL		01
UX04LEN	4	
UX04LIB		04
UX04LIBN	8C	
UX04LS		14
UX04MAIN	62	
UX04NLIB		08
UX04NSUB		10
UX04PRSN	1C	
UX04REPL		0C
UX04SPID		E6
UX04SSUB	60	
UX04STPN	14	
UX04SUBP	8	
UX04UAFF		80
UX04ULEN	30	
UX04UNIT	6A	
UX04USER	2C	
UX04UX04	0	
UX04VIRT		18

Programmatic Interface Authorization User Exit (SCSUX05)

Functional Description

The Programmatic Interface (PGMI) Authorization user exit (SCSUX05) allows you to perform authorization checking of programs requesting PGMI services. If the user exit disables itself (setting return code UX05NOPR) or abends, the MVS/CSC allows all programs to issue the query and read requests. In addition, you can use the SCSUX05 to interface with existing security products (i.e., RACF).

SCSUX05 is invoked for all requests received from the programmatic interface.

Environment

This user exit is applicable in both JES2 and JES3 environments. It is invoked by the MVS/CSC, and executes in the MVS/CSC's address space.

This user exit is invoked by the MVS/CSC for all requests received from the programmatic interface. SCSUX05 should evaluate the request and set a return code to indicate whether or not the MVS/CSC should allow the request to be executed. This exit is called from a nonspace switch program call (PC) in the requestor's address space under the requestor's request block (RB).



Note: This user exit must reside in a library defined in the IEAAPFyy member of the SYS1.PARMLIB.

Conditions when User Exit Routine is Executed

Parameter List

The parameter list is mapped by macro SCSUX05P.

Entry Specifications

Upon entry to SCSUX05, register contents are as follows:

Register	Contents
0	Undefined
1	Pointer to parameter list
2-12	Undefined
13	Pointer to register save area
14	Return address
15	Entry point address

Conditions on Return from User Exit

Return Specifications

On return from SCSUX05, register contents are as follows:

Register	Contents
0-14	Values at entry to exit
15	Return code (hexadecimal)

Return Codes

Table 31. SCSUX05 Return Codes

Return Code	Name	Description
0	UX05ALLOW	Allow the request
4	UX05DENY	Deny the request
40	UX05NOPR	The user exit is not operational Note: MVS/CSC will not call this exit again.

The StorageTek supplied version of SCSUX05 sets the return code to 40, which indicates an inactive user exit, and prevents the exit from being invoked again during the current MVS/CSC subsystem session. The MVS/CSC must be restarted before you can install and invoke a different version of SCSUX05.

Programming Considerations

A user word is provided in the parameter list. The contents of the word are passed from invocation to invocation of the user exit, and the user exit can change the contents. After an IPL or MVS/CSC COLD start, the contents of the word is initially zero; otherwise the contents are maintained across MVS/CSC startups. If the user word is used as a pointer, the area pointed to should be in common storage.



Note: There is no serialization provided. The user exit can be executing simultaneously under two task control blocks (TCBs). The user exit might want to serialize updates to any work area in which the user word might point to.

User Exit 05 Parameter List

The parameter list is built by user interface routines. The exit routine should examine the parameter list.

- If the user should be allowed to issue the request, register 15 should be set to UX05ALLOW.
- If the request is to be denied, UX05DENY should be set.
- If the exit is not to be called again, UX05NOPR should be set.

SCSUX05 Map

Offsets		Type/Value	Len	Name	Description
Dec	Hex				
0	(0)	STRUCTURE	32	SCSUX05P	User Exit 05 Parameter List
0	(0)	CHARACTER	4	UX05HDR	Eyecatcher
		'UX05'		UX05ID	Eyecatcher constant
4	(4)	FULLWORD	4	UX05LEN	Length of UX05 parameter list
8	(8)	ADDRESS	4	UX05REQA	SCSXREQM parameter list address
12	(C)	FULLWORD	4	UX05USER	Customer field; initially zero; preserved across calls
16	(10)	ADDRESS	4	UX05UDAT	Address of USERDATA parameter value
20	(14)	FULLWORD	4	UX05ULEN	Length of USERDATA parameter value
24	(18)	HEXSTRING	8	*	Reserved
32	(20)			UX05LSTL	Length of SCSUX05P

SCSUX05 Cross Reference

Name	Hex Offset	Hex Value
SCSUX05P	0	
UX05ALLOW		00
UX05DENY		04
UX05HDR	0	
UX05ID		'UX05'
UX05LEN	4	
UX05LSTL		20
UX05NOPR		40
UX05REQA	8	
UX05UDAT	10	
UX05ULEN	14	
UX05USER	C	

JES2 Specific Volume Allocation User Exit (SCSUX08)

Functional Description

The specific volume allocation user exit (SCSUX08) allows modification of the actions the SMC takes during the allocation of a specific volume DD statement that references cartridge drives. Use this exit to:

- Change the esoteric name (unit name) used for device allocation
- Request allocation of nonlibrary drives
- Request allocation of library drives
- Indicate a specific MVS/CSC subsystem name to use for allocation
- Bypass drive exclusion logic

User exit SCSUX08 is called for every allocation request for a specific volume to be mounted on a cartridge drive.

Environment

This user exit is applicable in JES2 environments. It is invoked by the SMC, and executes on the host where the SMC resides.

This user exit is invoked by the SMC for every allocation request for a specific volume on a cartridge tape device on a JES2 system. It is loaded using the SMC UEXit operator command. See “SMC UEXit command” on page 147 for more information about this command.



Note: This user exit must reside in a library accessible to the subsystem (SMC STEPLIB, JOBLIB, or you system’s LINKLIB concatenation).

Conditions when User Exit Routine is Executed**Parameter List**

The parameter list is mapped by macro SCSUX08P.

Entry Specifications

Upon entry to SCSUX08, register contents are as follows:

Register	Contents
0	Undefined
1	Pointer to parameter list
2-12	Undefined
13	Pointer to register save area
14	Return address
15	Entry point address

Conditions on Return from User Exit**Return Specifications**

On return from SCSUX08, register contents are as follows:

Register	Contents
0-14	Values at entry to exit
15	Return code (hexadecimal)

Return Codes

Table 32. SCSUX08 Return Codes

Return Code	Name	Description
0	UX08HJCL	Honor unit information in JCL
4	UX08ESUB	Request esoteric substitution; change esoteric name (unit name) defined in JCL
12	UX08NLIB	Request nonlibrary drives to satisfy allocation request
16	UX08NSUB	Direct allocation of drives to a specific ACS or MVS/CSC subsystem
20	UX08BSEP	Bypass drive exclusion
64	UX08IACT	The user exit is inactive

Programming Considerations

- Information regarding bypassing drive exclusion UX08BSEP:

The use of UX08BSEP (return code 20) should be carefully considered. There are several factors that will affect the final device that is allocated for a request that does not have drive exclusion performed on its behalf. These include:

- UNITNAME used in JCL (or SVC 99 request)
- DEVPREF setting
- Volume location (library vs. nonlibrary)
- TAPEREQ control statements
- DFSMS data class definitions
- Addresses of library and nonlibrary drives
- Presence of Cartridge Stacker Loaders (CSL) drives
- SELTAPE specification in IEAOPT member of PARMLIB
- Increased passthru events and ENTER/EJECT sequences requiring operator intervention will be experienced if this return code is used.
- A job should not go into allocation recovery if a device is available in the supplied UNITNAME if UX08BSEP is requested.

Examples

In the following example, the user exit instructs the SMC to direct the allocation for a specific volume request to nonlibrary devices.

```
set Register 15 to 12.
```

In the following example, the user exit requests esoteric substitution (LIBVOL), and instructs the SMC to direct the allocation to the library drives controlled by MVS/CSC subsystem CSC1.

```
set Register 15 to 16.  
set UX08ESO to 'LIBVOL'.  
set UX08ESO to 'CSC1'.  
set UX08ACS to 1.
```

User Exit 08 Parameter List

The parameter list is built by SMC Common Allocation SSREQ processing. The user exit is called for a specific allocation request. The user exit provides the ability to provide allocation criteria for a given DD statement.

SCSUX08 Map

Offsets		Type/Value	Len	Name	Description
Dec	Hex				
0	(0)	STRUCTURE	136	SCSUX08P	User Exit 08 Parameter List
0	(0)	CHARACTER	4	UX08UX08	Eyecatcher 'UX08'
4	(4)	FULLWORD	4	UX08LEN	Length of UX08 parameter list
8	(8)	HEXSTRING	1	UX08SUBP	Storage subpool number
		'E6'		UX08SPID	Subpool 230
9	(9)	HEXSTRING	1	UX08KEY	Storage key.
10	(A)	HEXSTRING	2	*	Reserved
12	(C)	CHARACTER	8	UX08JOBN	Job name
20	(14)	CHARACTER	8	UX08STPN	Step name
28	(1C)	CHARACTER	8	UX08PRSN	Procedure step name
36	(24)	CHARACTER	8	UX08DDN	DD name
44	(2C)	ADDRESS	4	UX08USER	Address of USERDATA parameter value
48	(30)	FULLWORD	4	UX08ULEN	Length of USERDATA parameter value
52	(34)	ADDRESS	4	UX08JACC	Address of job accounting information
55	(38)	ADDRESS	4	UX08SACC	Address of step accounting information
60	(3C)	CHARACTER	44	UX08DSN	Dataset name
104	(68)	HEXSTRING	4	*	Reserved
108	(6C)	FULLWORD	4	UX08NUMV	Number of volumes in dataset
112	(70)	CHARACTER	8	UX08ESO	Area to return esoteric name
120	(78)	CHARACTER	4	UX08CSCN	MVS/CSC subsystem to process request
124	(7C)	HEXSTRING	1	UX08ACS	Area to return an ACS ID
125	(7D)	CHARACTER	3	UX08XPDT	Dataset expiration date
128	(80)	BITSTRING	1	UX08LABT	Label type
		. 1..		UX08LBAL	Standard label
	1..		UX08LBNS	ANSI label
	1.		UX08LBSL	Nonlabeled
	1		UX08LBNL	Nonstandard label
129	(81)	HEXSTRING	7	*	Reserved
136	(88)			UX08LSTL	Length of SCSUX08P

SCSUX08 Cross Reference

Name	Hex Offset	Hex Value
SCSUX08P	0	
UX08ACS	7C	
UX08BSEP		14
UX08CSCN	78	
UX08DDN	24	
UX08DSN	3C	
UX08ESO	70	
UX08ESUB		04
UX08HJCL		00
UX08IACT		40
UX08JACC	34	
UX08JOBN	C	
UX08KEY	9	
UX08LABT	80	
UX08LBAL		40
UX08LBNL		01
UX08LBNS		04
UX08LBSL		02
UX08LEN	4	
UX08LSTL		88
UX08NLIB		0C
UX08NSUB		10
UX08NUMV	6C	
UX08PRSN	1C	
UX08SACC	38	
UX08SPID		E6
UX08STPN	14	
UX08SUBP	8	
UX08ULEN	30	
UX08USER	2C	
UX08UX08	0	
UX08XPDT	7D	

Deferred Mount User Exit (SCSUX09)

Functional Description

The deferred mount user exit allows you to determine whether or not a mount is MVS deferred.

By default, the MVS/CSC honors the specifications in your JCL, or the specification on the SMC ALLOCDef DEFer parameter. For example, if you do not request that a mount is deferred in your JCL or set DEFer(NO), the cartridge is mounted at step allocation time. If the mount request is for a specific volume and the data set is never opened, the cartridge is mounted and dismounted without being used. If the mount request is for a scratch volume and the data set is never opened, the cartridge is not dismounted.

If you request that a mount is deferred in your JCL or set DEFer(YES), the cartridge is not mounted until the data set is opened, thus leaving the LSM robot free to perform other tasks. While deferred mounting can reduce the number of mounts the LSM robot must perform, it might increase the time required to run a job. This occurs because the job waits until the cartridge is mounted before proceeding.

SCSUX09 provides you with the flexibility to allow or disallow the DEFer setting on an individual mount request. For example, if certain data sets need to be mounted prior to open time for performance reasons and your data center normally operates in deferred mode, SCSUX09 lets you override deferred mounting for the mount request. This exit is only invoked during common allocation; dynamic allocation requests are not deferred.

For JES3 environments running TAPE SETUP processing, you can set user exit SCSUX09 in conjunction with SCSUX11 to override the DEFer(NO) and DEFer(JES3) settings and defer a mount until data set open time. JES3 user exit SCSUX11 is called first to defer a mount until step allocation processing, and then SCSUX09 is called to defer the mount until data set open time. See “JES3 Deferred Mount User Exit (SCSUX11)” on page 128 for more information about user exit SCSUX11.

Environment

This user exit is applicable in both JES2 and JES3 environments. It is invoked by the SMC, and executes on the host where the SMC resides.

This user exit is loaded using the SMC UEXit operator command. See “SMC UEXit command” on page 147 for more information about this command.



Note: This user exit must reside in a library accessible to the subsystem (SMC STEPLIB, JOBLIB, or you system’s LINKLIB concatenation).

Conditions when User Exit Routine is Executed

Parameter List

The parameter list is mapped by macro SCSUX09P.

Entry Specifications

Upon entry to SCSUX09, register contents are as follows:

Register	Contents
0	Undefined
1	Pointer to parameter list
2-12	Undefined
13	Pointer to register save area
14	Return address
15	Entry point address

Conditions on Return from User Exit

Return Specifications

On return from SCSUX09, register contents are as follows:

Register	Contents
0-14	Values at entry to exit
15	Return code (hexadecimal)

Return Codes

Table 33. SCSUX09 Return Codes

Return Code	Name	Description
0	UX09CSC	Process normally; exit does not influence MVS defer status
4	UX09DFR	Defer the mount until the data set is opened
8	UX09NDFR	Honor the JCL defer status
12	UX09NVIR	Do not defer the virtual mount
64	UX09IACT	The user exit is inactive

Programming Considerations

Examples

In the following example, the user exit directs the SMC to defer the mount of a cartridge until the data set is opened.

```
set Register 15 to 4.
```

In the following example, the user exit directs the SMC to honor the defer status in the JCL.

```
set Register 15 to 8.
```

User Exit 09 Parameter List

The parameter list is built by SMC Common Allocation SSREQ processing. The user exit is called for a library volume allocation request. The return code from the user exit indicates the MVS defer status of the request.

SCSUX09 Map

Offsets		Type/Value	Len	Name	Description
Dec	Hex				
0	(0)	STRUCTURE	128	SCSUX09P	User Exit 09 Parameter List
0	(0)	CHARACTER	4	UX09UX09	Eyecatcher 'UX09'
4	(4)	FULLWORD	4	UX09LEN	Length of UX09 parameter list
8	(8)	HEXSTRING	1	UX09SUBP	Storage subpool number
		'E6'		UX09SPID	Subpool 230
9	(9)	HEXSTRING	1	UX09KEY	Storage key.
10	(A)	HEXSTRING	2	*	Reserved
12	(C)	CHARACTER	8	UX09JOBN	Job name
20	(14)	CHARACTER	8	UX09STPN	Step name
28	(1C)	CHARACTER	8	UX09PRSN	Procedure step name
36	(24)	CHARACTER	8	UX09PGMN	EXEC=program name
44	(2C)	CHARACTER	8	UX09DDN	DD name
52	(34)	ADDRESS	4	UX09USER	Address of USERDATA parameter value
56	(38)	FULLWORD	4	UX09ULEN	Length of USERDATA parameter value
60	(3C)	CHARACTER	44	UX09DSN	Dataset name
104	(68)	HEXSTRING	16	*	Reserved
120	(78)	BITSTRING	1	UX09DDCH	Dataset characteristics
		1... ..		UX09SPEC	Specific volume request
		.1... ..		UX09NSPC	Nonspecific volume request
121	(79)	HEXSTRING	7	*	Reserved
128	(80)			UX09LSTL	Length of SCSUX09P

SCSUX09 Cross Reference

Name	Hex Offset	Hex Value
SCSUX09P	0	
UX09CSC		00
UX09DDCH	78	
UX09DDN	2C	
UX09DFR		04
UX09DSN	3C	
UX09IACT		40
UX09JOBN	C	
UX09KEY	9	
UX09LEN	4	
UX09LSTL		80
UX09NDFR		08
UX09NSPC		40
UX09NVIR		0C
UX09PGMN	24	
UX09PRSN	1C	
UX09SPEC		80
UX09SPID		E6
UX09STPN	14	
UX09SUBP	8	
UX09ULEN	38	
UX09USER	34	
UX09UX09	0	

JES2 Unit Affinity Separation User Exit (SCSUX10)

Functional Description

This user exit allows you to request modification of the actions taken by the SMC during allocation of a unit affinity chain or GDG ALL chain that references cartridge drives.

You can use this user exit to:

- override the current settings on the SMC ALLOCDef command SEPLvl parameter
- change the esoteric name (unit name) used to allocate the chain
- request allocation of library drives for the chain
- request allocation of nonlibrary drives for the chain
- indicate a specific ACS or MVS/CSC subsystem to use for allocation

Environment

This user exit is applicable in JES2 environments. It is invoked by the SMC, and executes on the host where the SMC resides.

This user exit is invoked by the SMC for every unit affinity chain or GDG ALL chain that requires allocation. It is loaded using the SMC UEXit operator command. See “SMC UEXit command” on page 147 for more information about this command.



Note: This user exit must reside in a library accessible to the subsystem (SMC STEPLIB, JOBLIB, or your system's LINKLIB concatenation).

Conditions when User Exit Routine is Executed

Parameter List

The parameter list is mapped by macro SCSUX10P.

Entry Specifications

Upon entry to SCSUX10, register contents are as follows:

Register	Contents
0	Undefined
1	Pointer to parameter list
2-12	Undefined
13	Pointer to register save area
14	Return address
15	Entry point address

Conditions on Return from User Exit

Return Specifications

On return from SCSUX10, register contents are as follows:

Register	Contents
0-14	Values at entry to exit
15	Return code (hexadecimal)

Return Codes

Table 34. SCSUX10 Return Codes

Return Code	Name	Description
0	UX10PLIB	Perform separation according to the SEPLvl parameter of the ALLOCDef or ALLOCJob commands
4	UX10NSEP	Do not separate the chain
8	UX10SEP	Separate the chain
12	UX10LDRV	Allocate library drives, but do not separate the chain
16	UX10NDRV	Allocate nonlibrary drives, but do not separate the chain
20	UX10ESUB	Perform esoteric substitution using the specified esoteric name, but do not separate the chain
24	UX10NSUB	Direct allocation to a specific ACS or MVS/CSC subsystem name, but do not separate the chain
64	UX10IACT	The user exit is inactive

Programming Considerations

This exit can request esoteric substitution (or ACS specification) or separation, but not both. These requests are mutually exclusive.

Example

In the following example, the user exit directs the SMC to perform separation according to the current setting of the SEPLvl parameter of the ALLOCDef or ALLOCJob command.

```
set Register 15 to 0.
```

User Exit 10 Parameter List

The parameter list is built by SMC Common Allocation SSREQ processing. The user exit is called for each unit affinity chain or unqualified GDG specified in the invoking JCL. SCSUX10 provides the ability to request unit affinity separation for datasets which belong to a single affinity chain or an unqualified GDG and the required volumes reside in different physical locations (e.g., inside and outside an ACS).

SCSUX10 Map

Offsets		Type/Value	Len	Name	Description
Dec	Hex				
0	(0)	STRUCTURE	72	SCSUX10P	User Exit 10 Parameter List
0	(0)	CHARACTER	4	UX10UX10	Eyecatcher 'UX10'
4	(4)	FULLWORD	4	UX10LEN	Length of UX10 parameter list
8	(8)	HEXSTRING 'E6'	1	UX10SUBP UX10SPID	Storage subpool number Subpool 230
9	(9)	HEXSTRING	1	UX10KEY	Storage key.
10	(A)	HEXSTRING	2	*	Reserved
12	(C)	CHARACTER	8	UX10JOBN	Job name
20	(14)	CHARACTER	8	UX10STPN	Step name
28	(1C)	CHARACTER	8	UX10PRSN	Procedure step name
36	(24)	ADDRESS	4	UX10USER	Address of USERDATA parameter value
40	(28)	FULLWORD	4	UX10ULEN	Length of USERDATA parameter value
44	(2C)	ADDRESS	4	UX10JACC	Address of job accounting information
48	(30)	ADDRESS	4	UX10SACC	Address of step accounting information
52	(34)	FULLWORD	4	UX10DCNT	Number of DDs in affinity chain
56	(38)	CHARACTER	8	UX10ESO	Area to return an esoteric name
64	(40)	CHARACTER	4	UX10CSCN	MVS/CSC subsystem to process request
68	(44)	HEXSTRING	1	UX10ACS	Area to return an ACS ID
69	(45)	HEXSTRING	3	*	Reserved
72	(48)			UX10FIXL	Length of fixed portion of parameter list

SCSUX10

The following area immediately follows the SLSUX10P fixed data area. This area repeats once for each DD statement in the affinity chain. The number of DD statements in the affinity chain is stored in field UX10DCNT.

Offsets					
Dec	Hex	Type/Value	Len	Name	Description
0	(0)	STRUCTURE	80	SCSUX10D	User Exit 10 Dataset Parm List
0	(0)	CHARACTER	8	UX10DDN	DD name
8	(8)	CHARACTER	44	UX10DSN	Dataset name
52	(34)	ADDRESS	4	UX10VOLP	Pointer to volume information
56	(38)	FULLWORD	4	UX10VCNT	Number of volumes in dataset
60	(3C)	CHARACTER	3	UX10XPDT	Dataset expiration date from JFCB
63	(3F)	BITSTRING	1	UX10LABT	Label type from JFCB
		.1		UX10LBAL	ANSI label
	1 . .		UX10LBNS	Nonstandard label
	1 .		UX10LBSL	Standard label
	1		UX10LBNL	Nonlabeled
64	(40)	BITSTRING	1	UX10GDGI	GDG information
		1		UX10GDG	Dataset is part of GDGALL
		.1		UX10NGDG	Dataset is GDG single
65	(41)	HEXSTRING	15	*	Reserved
80	(50)			UX10DSNL	Length of dataset entry

The following area is pointed to by UX10VOLP. For a specific request, UX10VSER contains the volume serial. For a nonspecific request, UX10VSER contains "SCRATCH". If the specific volume resides in the library, UX10LSM will contain its library location. For all other requests UX10LSM will contain zeros.

Offsets					
Dec	Hex	Type/Value	Len	Name	Description
0	(0)	STRUCTURE	16	SCSUX10V	User Exit 10 Volume Parm List
0	(0)	CHARACTER	6	UX10VLSR	Volume serial
6	(6)	BITSTRING	1	UX10VLOC	Volume location
		1		UX10VLIB	Specific volume resides in library
		.1		UX10VNLB	Specific volume resides outside library
		. .1		UX10VSCR	Nonspecific volume request
7	(7)	HEXSTRING	2	UX10LSM	If specific volume in library, the library location in ACS/LSM format 'AALL' (hexadecimal)
9	(9)	HEXSTRING	7	*	Reserved
16	(10)			UX10VOLL	Length of volume entry

SCSUX10 Cross Reference

<u>Name</u>	<u>Hex Offset</u>	<u>Hex Value</u>
SCSUX10D	0	
SCSUX10P	0	
SCSUX10V	0	
UX10ACS	44	
UX10CSCN	40	
UX10DCNT	34	
UX10DDN	0	
UX10DSN	8	
UX10DSNL		50
UX10ESO	38	
UX10ESUB		14
UX10FIXL		48
UX10GDG		80
UX10GDGI	40	
UX10IACT		40
UX10JACC	2C	
UX10JOBN	C	
UX10KEY	9	
UX10LABT	3F	
UX10LBAL		40
UX10LBNL		01
UX10LBNS		04
UX10LBSL		02
UX10LDRV		0C
UX10LEN	4	
UX10LSM	07	
UX10NDRV		10
UX10NGDG		40
UX10NSEP		04
UX10NSUB		18
UX10PLIB		00
UX10PRSN	1C	
UX10SACC	30	
UX10SEP		08
UX10SPID		E6
UX10STPN	14	
UX10SUBP	8	
UX10ULEN	28	
UX10USER	24	
UX10UX10	0	
UX10VCNT	38	
UX10VLIB		80
UX10VLOC	6	
UX10VLSR	0	
UX10VNLB		40
UX10VOLL		10
UX10VOLP	34	
UX10VSCR		20
UX10XPDT	3C	

JES3 Deferred Mount User Exit (SCSUX11)

Functional Description

The deferred mount user exit is invoked during JES3 converter/interpreter (CI) processing. This user exit allows you to determine whether or not a mount is deferred until step allocation processing.

By default, the MVS/CSC honors the specifications in your JCL, or the specification from the SMC ALLOCDef DEFer parameter. You can use SCSUX11 to override the settings on the DEFer parameter.

When user exit SCSUX11 is set to defer a mount until step allocation processing, user exit SCSUX09 is also called during step allocation processing. You can use user exit SCSUX09 to override the DEFer(NO) and DEFer(JES3) settings and defer a mount until data set open time.

See “Deferred Mount User Exit (SCSUX09)” on page 117 for more information about user exit SCSUX09.

Environment

This user exit is applicable in JES3 environments. It is invoked by the SMC, and executes on the host where the SMC resides.

This user exit is loaded using the SMC UEXit operator command. See “SMC UEXit command” on page 147 for more information about this command.



Note: This user exit must reside in a library accessible to the subsystem (SMC STEPLIB, JOBLIB, or your system’s LINKLIB concatenation).

Conditions when User Exit Routine is Executed

Parameter List

The parameter list is mapped by macro SCSUX11P.

Entry Specifications

Upon entry to SCSUX11, register contents are as follows:

Register	Contents
0	Undefined
1	Pointer to parameter list
2-12	Undefined
13	Pointer to register save area
14	Return address
15	Entry point address

Conditions on Return from User Exit

Return Specifications

On return from SCSUX11, register contents are as follows:

Register	Contents
0-14	Values at entry to exit
15	Return code (hexadecimal)

Return Codes

Table 35. SCSUX11 Return Codes

Return Code	Name	Description
0	UX11CSC	Process normally; exit does not influence JES3 defer status
4	UX11DFR	Defer the mount until a system initiator begins the step allocation process
8	UX11NDFR	Honor the JCL's JES3 defer status
64	UX11IACT	The user exit is inactive

Example

In the following example, the user exit directs the SMC to defer the mount of a cartridge until step allocation.

```
set Register 15 to 4.
```

User Exit 11 Parameter List

The parameter list is built during JES3 device separation processing. The user exit is called for a library volume allocation request. The return code from the user exit indicates the JES3 defer status of the request.

SCSUX11 Map

Offsets		Type/Value	Len	Name	Description
Dec	Hex				
0	(0)	STRUCTURE	120	SCSUX11P	User Exit 11 Parameter List
0	(0)	CHARACTER	4	UX11UX11	Eyecatcher 'UX11'
4	(4)	FULLWORD	4	UX11LEN	Length of UX11 parameter list
8	(8)	HEXSTRING	1	UX11SUBP	Storage subpool number
		'E6'		UX11SPID	Subpool 230
9	(9)	HEXSTRING	1	UX11KEY	Storage key.
10	(A)	HEXSTRING	2	*	Reserved
12	(C)	CHARACTER	8	UX11JOBN	Job name
20	(14)	CHARACTER	8	UX11STPN	Step name
28	(1C)	CHARACTER	8	UX11PRSN	Procedure step name
36	(24)	CHARACTER	8	UX11DDN	DD name
44	(2C)	CHARACTER	44	UX11DSN	Dataset name
88	(58)	ADDRESS	4	UX11USER	Address of USERDATA parameter value
92	(5C)	FULLWORD	4	UX11ULEN	Length of USERDATA parameter value
96	(60)	HEXSTRING	16	*	Reserved
112	(70)	BITSTRING	1	UX11DDCH	Dataset characteristics
		1... ..		UX11SPEC	Specific volume request
		.1... ..		UX11NSPC	Nonspecific volume request
113	(71)	HEXSTRING	7	*	Reserved
120	(78)			UX11LSTL	Length of SCSUX11P

SCSUX11 Cross Reference

Name	Hex Offset	Hex Value
SCSUX11P	0	
UX11CSC		00
UX11DDCH	70	
UX11DDN	24	
UX11DFR		04
UX11DSN	2C	
UX11IACT		40
UX11JOBN	C	
UX11KEY	9	
UX11LEN	4	
UX11LSTL		78
UX11NDFR		08
UX11NSPC		40
UX11PRSN	1C	
UX11SPEC		80
UX11SPID		E6
UX11STPN	14	
UX11SUBP	8	
UX11ULEN	5C	
UX11USER	58	
UX11UX11	0	

JES3 Unit Affinity Separation User Exit (SCSUX12)

Functional Description

This user exit allows you to request modification of the actions taken by the SMC during allocation of a unit affinity chain or GDG ALL chain that references cartridge drives.

You can use this user exit to:

- override the current settings on the SMC ALLOCDef command SEPLvl parameter
- change the esoteric name (unit name) used to allocate the chain
- request allocation of library drives for the chain
- request allocation of nonlibrary drives for the chain
- indicate a specific ACS or MVS/CSC subsystem to use for allocation

Environment

This user exit is applicable in JES3 environments. It is invoked by the SMC, and executes on the host where the SMC resides.

This user exit is invoked by the SMC for every unit affinity chain or GDG ALL chain that requires allocation. It is loaded using the SMC UEXit operator command. See “SMC UEXit command” on page 147 for more information about this command.



Note: This user exit must reside in a library accessible to the subsystem (SMC STEPLIB, JOBLIB, or your system's LINKLIB concatenation).

Conditions when User Exit Routine is Executed

Parameter List

The parameter list is mapped by macro SCSUX12P.

Entry Specifications

Upon entry to SCSUX12, register contents are as follows:

Register	Contents
0	Undefined
1	Pointer to parameter list
2-12	Undefined
13	Pointer to register save area
14	Return address
15	Entry point address

Conditions on Return from User Exit

Return Specifications

On return from SCSUX12, register contents are as follows:

Register	Contents
0-14	Values at entry to exit
15	Return code (hexadecimal)

Return Codes

Table 36. SCSUX12 Return Codes

Return Code	Name	Description
0	UX12CSC	Perform separation according to the SEPLvl parameter of the ALLOCDef or ALLOCJob commands
4	UX12LIB	Do not separate the chain
8	UX12NLIB	Separate the chain
12	UX12REPL	Allocate library drives, but do not separate the chain
16	UX12NSUB	Allocate nonlibrary drives, but do not separate the chain
20	UX12SEP	Perform esoteric substitution using the specified esoteric name, but do not separate the chain
64	UX12IACT	The user exit is inactive

Programming Considerations

Unit affinity separation might cause the number of units, in which the requester needs to allocate, to increase. Separation will not be performed if this increase causes the job to fail.

Example

In the following example, the user exit directs the SMC to perform separation according to the current setting of the SEPLvl parameter of the ALLOCDef or ALLOCJob command.

```
set Register 15 to 0.
```

The parameter list is built during device separation. The user exit is called to allow the customer to determine whether an affinity chain of DD statements should share the same unit as specified, or whether the chain should be broken. This break allows allocation of drives in the same physical location as the tape volumes required.

User Exit 12 Parameter List

The parameter list is built during device separation. The user exit is called to allow the customer to determine whether an affinity chain of DD statements should share the same unit as specified, or whether the chain should be broken. This break allows allocation of drives in the same physical location as the tape volumes required.

SCSUX12 Map

Offset		Type/Value	Len	Name	Description
Dec	Hex				
0	(0)	STRUCTURE	84	SCSUX12P	User Exit 12 Parameter List
0	(0)	CHARACTER	4	UX12UX12	Eyecatcher 'UX12'
4	(4)	FULLWORD	4	UX12LEN	Length of UX12 parameter list
8	(8)	HEXSTRING	1	UX12SUBP	Storage subpool number
		'E6'		UX12SPID	Subpool 230
9	(9)	HEXSTRING	1	UX12KEY	Storage key.
10	(A)	HEXSTRING	2	*	Reserved
12	(C)	CHARACTER	8	UX12JOBN	Job name
20	(14)	CHARACTER	8	UX12STPN	Step name
28	(1C)	CHARACTER	8	UX12PRSN	Procedure step name
36	(24)	ADDRESS	4	UX12USER	Address of USERDATA parameter value
40	(28)	FULLWORD	4	UX12ULEN	Length of USERDATA parameter value
44	(2C)	FULLWORD	4	UX12DCNT	Number of DDs in affinity chain
48	(30)	CHARACTER	8	UX12UNIT	JCL unit name
56	(38)	CHARACTER	8	UX12ESOT	Area to return an esoteric name
64	(40)	CHARACTER	4	UX12CSCN	MVS/CSC subsystem to process request
68	(44)	FULLWORD	4	UX12ACS	Area to return an ACS ID; format: 00000AA, where AA = ACS number
72	(48)	CHARACTER	8	UX12MAIN	JES3 setup processor
80	(50)	BITSTRING	1	UX12AFF	Type of affinity
		1... ..		UX12GDG	GDG affinity
		.1... ..		UX12UAFF	Unit affinity
81	(51)	HEXSTRING	3	*	Reserved
84	(54)			UX12FIXL	Length of fixed portion of parameter list

The following area immediately follows the SCSUX12P fixed data area. This area repeats once for each DD statement in the affinity chain. The number of DD statements in the affinity chain is stored in field UX12DCNT.

Offsets		Type/Value	Len	Name	Description
Dec	Hex				
0	(0)	STRUCTURE	64	SCSUX12D	User Exit 12 Dataset Parm List
0	(0)	CHARACTER	8	UX12DDN	DD name
8	(8)	CHARACTER	44	UX12DSN	Dataset name
52	(34)	FULLWORD	4	UX12NUMV	Number of volumes in dataset
56	(38)	BITSTRING	1	UX12LABT	Label type
			UX12LBDF	Library default label type
	1		UX12LBSL	Standard label
	1.		UX12LBAL	ANSI label
	11		UX12LBNL	Nonlabeled
	1..		UX12LBNS	Nonstandard label
57	(39)	HEXSTRING	1	UX12SSUB	Scratch subpool number
58	(3A)	HEXSTRING	2	*	Reserved
60	(3C)	ADDRESS	4	UX12VOLP	Pointer to volume information
64	(40)			UX12VARL	Length of dataset entry

The following area is pointed to by UX12VOLP. It consists of the volume serial and location of each volume in the data set. The number of volume entries in the list is provided by UX12NUMV.

Offsets		Type/Value	Len	Name	Description
Dec	Hex				
0	(0)	STRUCTURE	12	SCSUX12V	User Exit 12 Volume Parm List
0	(0)	CHARACTER	6	UX12VLSR	Volume serial
6	(6)	BITSTRING	1	UX12VREQ	Volume requested
		1... ..		UX12SPEC	Specific volume requested
		.1... ..		UX12NSPC	Nonspecific volume request
7	(7)	BITSTRING	1	UX12VLOC	Volume location
		1... ..		UX12VLIB	Volume resides in library
		.1... ..		UX12VNLB	Volume resides outside library
8	(8)	HEXSTRING	2	UX12AALL	If volume in library, the library location in ACS/LSM format 'AALL' (hexadecimal)
10	(A)	HEXSTRING	2	*	Reserved
12	(C)			UX12VLTL	Length of volume entry

SCSUX12 Cross Reference

Name	Hex Offset	Hex Value
SCSUX12D	0	
SCSUX12P	0	
SCSUX10V	0	
UX12AALL	8	
UX12ACS	44	
UX12AFF	50	
UX12CSC		00
UX12CSCN	40	
UX12DCNT	2C	
UX12DDN	0	
UX12DSN	8	
UX12ESOT	38	
UX12FIXL		54
UX12GDG		80
UX12IACT		40
UX12JOBN	C	
UX12KEY	9	
UX12LABT	38	
UX12LBAL		02
UX12LBDF		00
UX12LBNL		03
UX12LBNS		04
UX12LBSL		01
UX12LEN	4	
UX12LIB		04
UX12MAIN	48	
UX12NLIB		08
UX12NSPC		40
UX12NSUB		10
UX12NUMV	34	
UX12PRSN	1C	
UX12REPL		0C
UX12SEP		14
UX12SPEC		80
UX12SPID		E6
UX12SSUB	39	
UX12STPN	14	
UX12SUBP	8	
UX12ULEN	28	
UX12USER	24	
UX12UAFF		40
UX12UNIT	30	
UX12UX12	0	
UX12VARL		40
UX12VLIB		80
UX12VLOC	7	
UX12VLSR	0	
UX12VLTL		0C
UX12VNLB		40

SCSUX12

Name	Hex Offset	Hex Value
UX12VOLP	3C	
UX12VREQ	6	

JES3 Specific Volume Allocation User Exit (SCSUX13)

Functional Description

The specific volume allocation user exit (SCSUX13) allows modification of the actions the SMC takes during the allocation of a specific volume DD statement that references cartridge drives. Use this exit to:

- Change the esoteric name (unit name) used for device allocation
- Request allocation of nonlibrary drives
- Request allocation of library drives
- Indicate a specific MVS/CSC subsystem name to use for allocation
- Bypass drive exclusion logic

Environment

This user exit is applicable in JES3 environments. It is invoked by the SMC, and executes on the host where the SMC resides.

This user exit is invoked by the SMC for every allocation request for a specific volume to be mounted on a cartridge drive. It is loaded using the SMC UEXit operator command. See “SMC UEXit command” on page 147 for more information about this command.



Note: This user exit must reside in a library accessible to the subsystem (SMC STEPLIB, JOBLIB, or you system’s LINKLIB concatenation).

Conditions when User Exit Routine is Executed**Parameter List**

The parameter list is mapped by macro SCSUX13P.

Entry Specifications

Upon entry to SCSUX13, register contents are as follows:

Register	Contents
0	Undefined
1	Pointer to parameter list
2-12	Undefined
13	Pointer to register save area
14	Return address
15	Entry point address

Conditions on Return from User Exit**Return Specifications**

On return from SCSUX13, register contents are as follows:

Register	Contents
0-14	Values at entry to exit
15	Return code (hexadecimal)

Return Codes

Table 37. SCSUX13 Return Codes

Return Code	Name	Description
0	UX13CSC	Process normally; exit does not influence JES3 defer status
4	UX13LIB	Defer the mount until a system initiator begins the step allocation process
8	UX13NLIB	Honor the JCL's JES3 defer status
12	UX13REPL	Replace unit name with a different esoteric
16	UX13NSUB	Direct allocation of drives to a specific ACS or MVS/CSC subsystem
64	UX13IACT	The user exit is inactive

Programming Considerations

Examples

In the following example, the user exit instructs the SMC to direct the allocation for a specific volume request to nonlibrary drives.

```
set Register 15 to 8.
```

In the following example, the user exit requests esoteric substitution (LIBVOL), and instructs the SMC to direct the allocation to the library drives controlled by MVS/CSC subsystem CSC1.

```
set Register 15 to 16.
set UX13ESOT to 'LIBVOL'.
set UX13CSCN to 'CSC1'.
set UX13ACS to 1.
```

User Exit 13 Parameter List

The parameter list is built by SMC during JES3 device separation. The user exit is called for a specific allocation request. The user exit provides the ability to provide allocation criteria for a given DD statement.

SCSUX13 Map

Offsets		Type/Value	Len	Name	Description
Dec	Hex				
0	(0)	STRUCTURE	176	SCSUX13P	User Exit 13 Parameter List
0	(0)	CHARACTER	4	UX13UX13	Eyecatcher 'UX13'
4	(4)	FULLWORD	4	UX13LEN	Length of UX13 parameter list
8	(8)	HEXSTRING	1	UX13SUBP	Storage subpool number
		'E6'		UX13SPID	Subpool 230
9	(9)	HEXSTRING	1	UX13KEY	Storage key.
10	(A)	HEXSTRING	2	*	Reserved
12	(C)	CHARACTER	8	UX13JOBN	Job name
20	(14)	CHARACTER	8	UX13STPN	Step name
28	(1C)	CHARACTER	8	UX13PRSN	Procedure step name
36	(24)	CHARACTER	8	UX13DDN	DD name
44	(2C)	ADDRESS	4	UX13USER	Address of USERDATA parameter value
48	(30)	FULLWORD	4	UX13ULEN	Length of USERDATA parameter value
52	(34)	ADDRESS	8	UX13UNIT	JCL unit name
60	(3C)	CHARACTER	8	UX13ESOT	Area to return an esoteric name
68	(44)	CHARACTER	4	UX13CSCN	MVS/CSC subsystem to process request
72	(48)	FULLWORD	4	UX13ACS	Area to return an ACS ID; format: 000000AA, where AA is the ACS number
76	(4C)	CHARACTER	44	UX13DSN	Dataset name
120	(78)	BITSTRING	1	UX13LABT	Label type
			UX13LBDF	Library default label type
	 1		UX13LBSL	Standard label
	 1.		UX13LBAL	ANSI label
	 11		UX13LBNL	Nonlabeled
	 1..		UX13LBNS	Nonstandard label
121	(79)	CHARACTER	8	UX13MAIN	JES3 setup processor
129	(81)	HEXSTRING	3	*	Reserved
132	(84)	FULLWORD	4	UX13NUMV	Number of volumes in dataset
136	(88)	ADDRESS	4	UX13VOLP	Address of volume information
140	(8C)	BITSTRING	1	UX13FLG1	User exit 13 flag
		1... ..		UX13UAFF	Element is member of unit affinity chain
		.1... ..		UX13GAFF	Element is member of GDGALL chain
141	(8D)	HEXSTRING	35	*	Reserved
176	(B0)			UX13LSTL	Length of SCSUX13P

Offsets		Type/Value	Len	Name	Description
Dec	Hex				
0	(0)	STRUCTURE	9	SCSUX13V	User Exit 13 Volume Parm List
0	(0)	OFFSET	0	UX13VLST	Volume list
0	(0)	CHARACTER	6	UX13VLSR	Volume serial
6	(6)	BITSTRING	1	UX13VLOC	Volume location
		1... ..		UX13VLIB	Volume resides in library
		.1... ..		UX13VNLB	Volume resides outside library
7	(7)	HEXSTRING	2	UX13AALL	If volume in library, the library location in ACS/LSM format 'AALL' (hexadecimal)
9	(9)			UX13VLTl	Length of volume entry

Chapter 4. Implementing SMC-Managed User Exits

Overview

This chapter describes how SMC-managed user exits are implemented. The following user exits are invoked and managed by the SMC:

Table 38. SMC-Managed User Exits

Exit Number	Exit Name	Description
1	SLSUX01 SCSUX01	Message Handling User Exit
2	SLSUX02 SCSUX02	JES2 Scratch Allocation User Exit
4	SLSUX04 SCSUX04	JES3 Scratch Allocation User Exit
8	SLSUX08 SCSUX08	JES2 Specific Volume Allocation User Exit
9	SLSUX09 SCSUX09	Deferred Mount User Exit
10	SLSUX10 SCSUX10	JES2 Unit Affinity Separation User Exit
11	SLSUX11 SCSUX11	JES3 Deferred Mount User Exit
12	SLSUX12 SCSUX12	JES3 Unit Affinity Separation User Exit
13	SLSUX13 SCSUX13	JES3 Specific Volume Allocation User Exit

These user exits provide control over message handling functions and client allocation. They are implemented using the SMC UEXit operator command.

Sample user exits are distributed as follows:

- SMC managed JES2 user exits and the message handling user exit are distributed in the SMC JES2 SAMPLIB (UX nn HSC n).
- SMC managed JES3 user exits are distributed in the SMC JES3 SAMPLIB (UX nn HSC n).



Notes:

- These user exits are executed on the host where the SMC resides, regardless of where the library server resides.
- Only one format (HSC or CSC) of each user exit is executed, regardless of the number of servers interacting with the SMC.

For example, if the SMC specifies two server statements, each of which define a separate path to a separate library, only one user exit 08 (SLSUX08 or SCSUX08) is executed on the SMC host to determine specific volume policy.

- If you are using both HSC and MVS/CSC, StorageTek recommends that you use the HSC format user exits, as support for MVS/CSC format user exits will end in a future SMC release.
- These user exits must reside in a library accessible to the subsystem (SMC STEPLIB, JOBLIB, or your system's LINKLIB concatenation).

SMC UEXit command

The UEXit command defines which load modules are invoked for a specific user exit, and whether the user exit is enabled or disabled. Both HSC and MVS/CSC user exit formats are supported. The UEXit command can be used to specify the desired format.



Note: Use this command to load each user exit you wish to use. If a user exit is not loaded, it will **not** be called.

Syntax

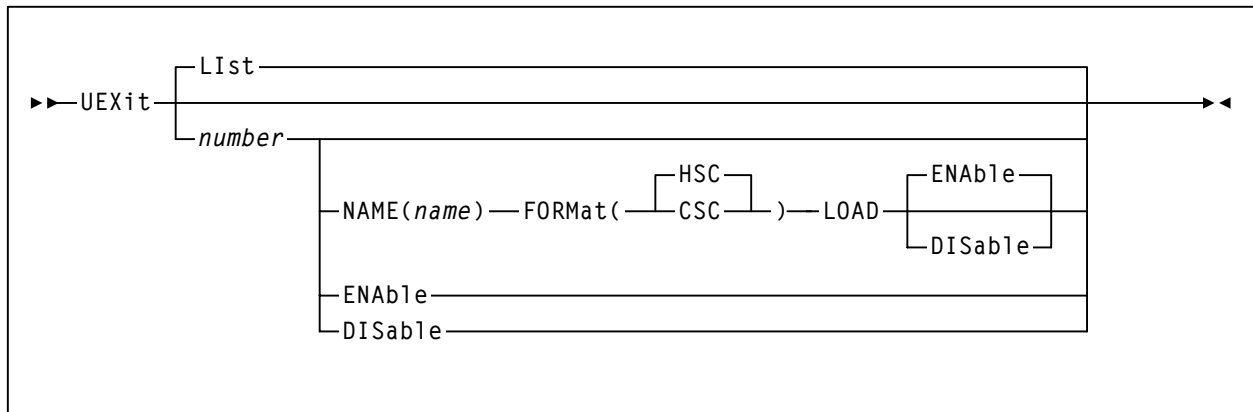

Command Name

UEXit

Initiates the UEXit command.

Parameter Descriptions

List

optionally, displays status information for all user exits. This is the default if no parameters are specified.

number

optionally, specifies the user exit number. Valid values are 1, 2, 4, 8, 9, 10, 11, 12, and 13.

NAME

optionally, specifies the user exit's load module name

name

indicates the load module name (e.g., SLSUX01)

FORMat

optionally, specifies the format of user exit to be enabled or disabled.

HSC

indicates the HSC user exit format.

CSC

indicates the MVS/CSC user exit format.

LOAD

optionally, loads the specified user exit, making it available for use.



Notes:

- If a user exit is not loaded, it will **not** be called.
- A subsequent load of a module for the same user exit causes the currently active copy of the load module to be deleted when its use count reaches zero.

ENable

optionally, enables a user exit that was previously disabled due to a problem.

DISable

optionally, disables a user exit to allow for problem resolution.

Example

In the following example, the UEXit command is used to load the HSC format (SLSUX01) of user exit 01.

```
UEXIT 01 NAME(SLSUX01) FORMAT(HSC) LOAD
```

SLSUX01 is loaded from the SMC STEPLIB, JOBLIB, or your system's linklib concatenation.

Chapter 5. Implementing HSC-Managed User Exits

Overview

This chapter describes how HSC-managed user exits are implemented. The following user exits are invoked and managed by the HSC:

Table 39. HSC-Managed User Exits

Exit Number	Exit Name	Description
3	SLSUX03	HSC Scratch Subpool User Exit
5	SLSUX05	Programmatic Interface Authorization User Exit
6	SLSUX06	HSC Insert/Delete User Exit
14	SLSUX14	HSC Volume Access User Exit
15	SLSUX15	HSC Command Authorization User Exit

These user exits are loaded at HSC subsystem initialization from the load library identified by ddname SLSUEXIT, or from the HSC load library with the default names.

- Each user exit can be defined to the HSC with the UEXIT PARMLIB control statement. Issue a separate control statement for each user exit you want to invoke by substituting the exit number in the SLSUX nn parameter, or by specifying the entry point name used to link-edit the load module. The UEXIT statement allows you to load the exit in either an enabled or disabled state.
- If no UEXIT statement for a particular user exit is found in the HSC PARMLIB data set, the HSC loads that user exit's default stub from one of two sources:
 - the SLSUEXIT DD statement, if it is present in the HSC START procedure, or
 - the HSC load library, if SLSUEXIT does not exist.

Unless replaced by the customer, the HSC load library contains the StorageTek default stubs of each user exit and sets a return code of 64, indicating the user exit is inactive. When the HSC receives a return code of 64 from an initial call to the user exit, it does not call the exit again during that HSC session unless the exit is explicitly reloaded or activated using the UEXIT operator command.

The HSC UEXIT command can be used to dynamically enable, disable, reload, or query the status of user exits.



Notes:

- HSC managed user exits dummy exit source (SLSUXnn) and samples (UXnnSAMn) are distributed in the HSC SAMPLIB.
- When migrating to a new release of the HSC, you are not required to reassemble your user exits. However, if you choose to do so, StorageTek suggests that user modifications to user exits and other StorageTek-supplied programs be based on the source code shipped in the current release.
- If you are using both HSC and MVS/CSC, StorageTek recommends that you use HSC user exit formats, as support for MVS/CSC user exit formats will end in a future SMC release.
- In this chapter, the term JES2 includes JES3 without SETUP processing; the term JES3 refers to JES3 with SETUP processing.
- The SMC allows ESOTeric and SUBPool parameters to be specified in the TAPEREQ control statement as well as user exits. Customers should examine their user exits to determine whether they could be replaced with TAPEREQ parameters. Control statements can also be used to control affinity separation policy and defer policy.

Refer to the *Storage Management Component (SMC) Configuration and Administration Guide* for information on TAPEREQ and user exit interaction.

- User exit 7 (SLSUX07) is no longer supported.

HSC User Exit (UEXIT) Command and Control Statement

HSC user exits permit you to invoke your own processing routines at particular points during HSC processing. User exits controlled by the HSC are loaded at HSC initialization from the load library identified by DDNAME SLSUEXIT.

This command provides a way for you to define how the HSC processes your user exits by allowing you to start the HSC with a user exit disabled and then enable the exit at any time the HSC is operational. If an exit does not perform as expected, make the necessary changes and load it again.



Note: User Exit 03 is enabled at HSC initialization. The UEXIT command cannot be used to enable, disable, or reload that exit.

The UEXIT command optionally allows you to provide unique user exit load module names and to create different versions of an exit that can be run at different times (for example, day shift versus night shift). The load modules are contained in a user-defined load module library described at HSC startup.

Syntax

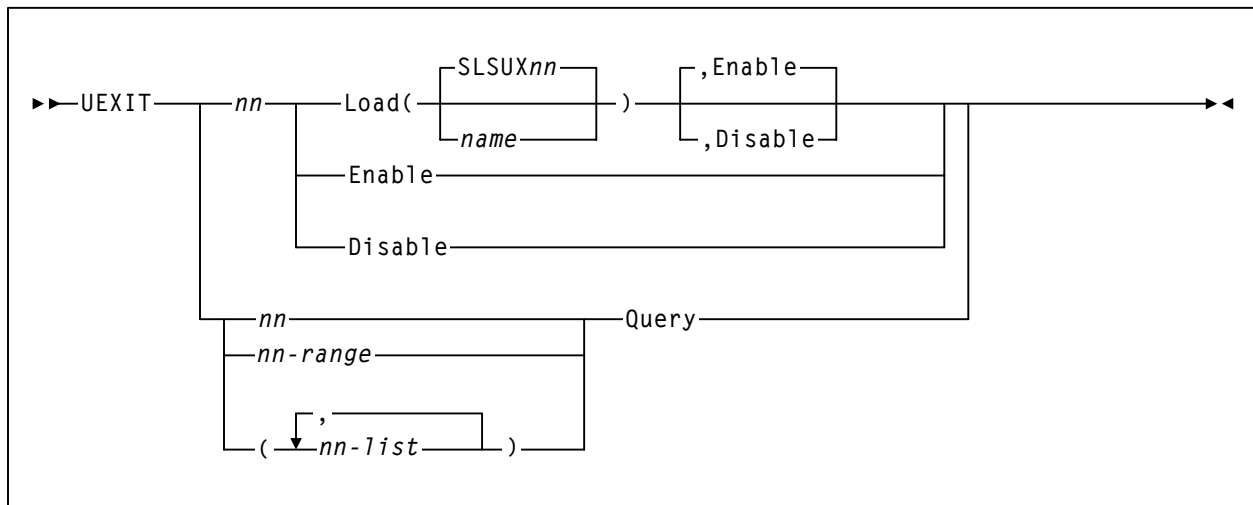

Command Name

UEXIT

initiates the UEXIT command and control statement.

Parameters

nn

specifies the user exit number.

Load

causes the specified module to be loaded into storage.

SLSUX*nn*

specifies the default name for the user exit. If *name* is not specified, then the default name is used when the HSC loads the module into storage.

name

specifies the name of the module to be used for this exit. This is the entry point name which is used to link-edit the load module.

Enable

indicates that upon completion of the command the specified exit is considered as being active. Enable is the default.

Disable

indicates that upon completion of the command the specified exit is considered as being inactive.

Enable

specifies that the most current module for the specified user exit (*nn*) is to be enabled. This parameter may also be specified with the Load parameter.

Disable

specifies that the most current module for the specified user exit (*nn*) is to be disabled. This parameter may also be specified with the Load parameter.

nn* or *nn-range* or *nn-list

can be used with the Query parameter to specify a single user exit, a range of exits, or a list of exits.

When specifying a range of user exit numbers, the beginning number must be separated from the ending number by a hyphen.

Example: (04-09)

In a list of user exits, the user exit numbers must be separated by commas and the list must be enclosed in parentheses.

Example: (01,04,10)

Query

requests the status of all the currently loaded versions of the specified user exit number(s). A display of user exit status may be specified for a single user exit, a range of exits, or a list of exits.

Examples

The following examples illustrate the use of the UEXIT command and control statement.

Load User Exit 03 - Enabled

```
UEXIT 03 LOAD
```

Load User Exit 06 - Disabled

```
UEXIT 06 LOAD(SLSUX12),DISABLE
```

Display Status of All Currently Loaded Versions of User Exit 05

```
UEXIT 05 Q
```

Display Status for a List of User Exits

```
UEXIT (03,05,06,14) Q
```

Display Status for a Range of User Exits

```
UEXIT 14-15 Q
```

Chapter 6. Implementing MVS/CSC-Managed User Exits

Overview

This chapter describes how MVS/CSC-managed user exits are implemented.

User exit 5 (SCSUX05), the Programmatic Interface Authorization User Exit, is the only MVS/CSC format user exit that is invoked and managed by the MVS/CSC. All remaining MVS/CSC format user exits are invoked and managed by the SMC. These user exits are implemented using the SMC UEXit operator command. They are executed on the host where the SMC resides, regardless of where the library server resides.

User exit 5 is loaded at MVS/CSC subsystem initialization, and is implemented using either of the following methods:

- Replacing the StorageTek supplied dummy entry in the executables library with a locally assembled and link-edited copy.
- Concatenating a library containing a local version of the user exit in front of the MVS/CSC executable library in the STEPLIB DD statement of the MVS/CSC START procedure.



Note: If you choose this method, the library containing the user exits must be authorized, even though the user exit routines do not require authorization.

Unless replaced by the customer, the MVS/CSC load library contains the StorageTek default stub for SCSUX05 and sets a return code of 64, indicating the user exit is inactive.



Notes:

- MVS/CSC managed user exit samples (UX nm CSC n) are distributed in the MVS/CSC SAMPLIB.
- If you are using both HSC and MVS/CSC, StorageTek recommends that you use HSC user exit formats, as support for MVS/CSC user exit formats will end in a future SMC release.
- In this chapter, the term JES2 includes JES3 without SETUP processing; the term JES3 refers to JES3 with SETUP processing.

- The SMC allows ESOTeric and SUBPool parameters to be specified in the TAPEREQ control statement as well as user exits. Customers should examine their user exits to determine whether they could be replaced with TAPEREQ parameters. Control statements can also be used to control affinity separation policy and defer policy.

Refer to the *Storage Management Component (SMC) Configuration and Administration Guide* for information on TAPEREQ and user exit interaction.





NEED MORE INFORMATION?
www.storagetek.com

ABOUT STORAGETEK

Storage Technology Corporation (NYSE: STK) is a \$2 billion global company that enables businesses, through its information lifecycle management strategy, to align the cost of storage with the value of information. The company's innovative storage solutions manage the complexity and growth of information, lower costs, improve efficiency and protect investments. For more information, visit www.storagetek.com, or call 1.800.275.4785 or 01.303.673.2800.

WORLD HEADQUARTERS

Storage Technology Corporation
One StorageTek Drive
Louisville, Colorado 80028 USA
1.800.678.4430 or 01.303.673.4430

© 2004 Storage Technology Corporation, Louisville, CO. All rights reserved. Printed in USA. StorageTek and the StorageTek logo are registered trademarks of Storage Technology Corporation. Other names mentioned may be trademarks of Storage Technology Corporation or other vendors/manufacturers.

StorageTek equipment is manufactured from new parts, or new and used parts. In some cases, StorageTek equipment may not be new and may have been previously installed. Regardless, StorageTek's standard warranty terms apply, unless the equipment is specifically identified by StorageTek as "used" or "refurbished."

Replacement parts provided under warranty or any service offering may be either new or equivalent-to-new, at StorageTek's option. Specifications/features may change without notice.