

# Veritas FlashSnap™ Agent for Symmetrix Administrator's Guide

Solaris

5.0

# Veritas FlashSnap Agent for Symmetrix Administrator's Guide

Copyright © 2006 Symantec Corporation. All rights reserved.

Veritas FlashSnap™ Agent 5.0 for Symmetrix

Symantec, the Symantec logo, and FlashSnap are trademarks or registered trademarks of Symantec Corporation or its affiliates in the U.S. and other countries. Other names may be trademarks of their respective owners.

The product described in this document is distributed under licenses restricting its use, copying, distribution, and decompilation/reverse engineering. No part of this document may be reproduced in any form by any means without prior written authorization of Symantec Corporation and its licensors, if any.

THIS DOCUMENTATION IS PROVIDED "AS IS" AND ALL EXPRESS OR IMPLIED CONDITIONS, REPRESENTATIONS AND WARRANTIES, INCLUDING ANY IMPLIED WARRANTY OF MERCHANTABILITY, FITNESS FOR A PARTICULAR PURPOSE OR NON-INFRINGEMENT, ARE DISCLAIMED, EXCEPT TO THE EXTENT THAT SUCH DISCLAIMERS ARE HELD TO BE LEGALLY INVALID, SYMANTEC CORPORATION SHALL NOT BE LIABLE FOR INCIDENTAL OR CONSEQUENTIAL DAMAGES IN CONNECTION WITH THE FURNISHING PERFORMANCE, OR USE OF THIS DOCUMENTATION. THE INFORMATION CONTAINED IN THIS DOCUMENTATION IS SUBJECT TO CHANGE WITHOUT NOTICE.

The Licensed Software and Documentation are deemed to be "commercial computer software" and "commercial computer software documentation" as defined in FAR Sections 12.212 and DFARS Section 227.7202.

Symantec Corporation  
20330 Stevens Creek Blvd.  
Cupertino, CA 95014  
[www.symantec.com](http://www.symantec.com)

## Third-party legal notices

Third-party software may be recommended, distributed, embedded, or bundled with this Symantec product. Such third-party software is licensed separately by its copyright holder. All third-party copyrights associated with this product are listed in the accompanying release notes.

Solaris is a trademark of Sun Microsystems, Inc.

## Licensing and registration

Veritas FlashSnap Agent for Symmetrix is a licensed product. See the Veritas FlashSnap Agent for Symmetrix Installation Guide for license installation instructions.

## Technical support

For technical assistance, visit <http://support.veritas.com> and select phone or email support. Use the Knowledge Base search feature to access resources such as TechNotes, product alerts, software downloads, hardware compatibility lists, and our customer email notification service.



# Contents

Chapter 1	Overview	
	What's in this manual .....	7
	Getting help .....	8
	Product message number .....	8
	Veritas FlashSnap Agent for Symmetrix .....	9
	Veritas FlashSnap Agent for Symmetrix utilities .....	9
	Veritas Cluster Server Agents for Veritas FlashSnap Agent for Symmetrix .....	10
	EMC Symmetrix disk arrays .....	11
	Device names .....	11
	EMC rules for Volume Manager .....	12
	Disk group rules .....	13
	Volume rules .....	15
	Unenforced rules .....	15
	Task roadmap .....	16
	Setup tasks (required) .....	16
	Administrative tasks (optional) .....	18
Chapter 2	Introduction to Veritas FlashSnap Agent for Symmetrix	
	Business continuance processes .....	21
	VxFAS components .....	22
	VxFAS operations .....	24
	Establish .....	24
	Split .....	26
	Re-establish .....	27
	Restore .....	28
	Incremental restore .....	29
	VxFAS features .....	31
Chapter 3	Using Veritas FlashSnap Agent for Symmetrix with VxVM	
	Adding devices to VxVM disk group .....	34
	Using EMC PowerPath devices with VxVM .....	34
	Creating volumes .....	39
	Attaching devices .....	41
	Mirroring disk groups .....	43
	Splitting disk groups .....	44

Remirroring disk groups .....	47
Restoring disk groups .....	49
Reattaching disk groups .....	52
Detaching devices .....	53
Recovering crashed commands .....	55
Viewing device information .....	56
Disk group reconfiguration .....	59
Policy setting support for EMC rules for Volume Manager .....	62

## Chapter 4 Using the Veritas FlashSnap Agent for Symmetrix with VEA

The VEA console .....	64
Configuring options for EMC Symmetrix arrays in the StorageAgent .....	65
Attaching devices .....	67
Mirroring devices .....	71
Splitting devices .....	73
Restoring devices .....	76
Detaching devices .....	78
Querying snapshot information .....	80
Recovering a crashed VxFAS operation .....	82
Recovering a crashed disk group reconfigure operation .....	83
Viewing object properties .....	84
Notes on VxFAS menu options .....	84

## Chapter 5 Troubleshooting

VxFAS pre-operation conditions .....	86
Common error messages .....	88
The vxtfexplorer.sh diagnostic script .....	92

Index .....	93
-------------	----

# Overview

This guide describes how to use the Veritas FlashSnap Agent for Symmetrix (VxFAS) and how to use Veritas Volume Manager™ (VxVM) in an EMC environment.

This guide is intended for system administrators responsible for configuring and maintaining the Veritas FlashSnap Agent for Symmetrix and the Veritas Volume Manager. This guide assumes you have:

- A working knowledge of the UNIX operating system
- A basic understanding of volume management
- A basic understanding of the EMC *TimeFinder* product

This chapter provides an overview of the Veritas FlashSnap Agent for Symmetrix (VxFAS). Topics include:

- [What's in this manual](#)
- [Getting help](#)
- [Veritas FlashSnap Agent for Symmetrix](#)
- [Veritas FlashSnap Agent for Symmetrix utilities](#)
- [Veritas Cluster Server Agents for Veritas FlashSnap Agent for Symmetrix](#)
- [EMC Symmetrix disk arrays](#)
- [Device names](#)
- [EMC rules for Volume Manager](#)
- [Task roadmap](#)

## What's in this manual

- [Chapter 1. "Overview" on page 7](#), describes how the Volume Manager and Veritas FlashSnap Agent for Symmetrix work in an EMC environment.

- [Chapter 2. “Introduction to Veritas FlashSnap Agent for Symmetrix” on page 21](#), introduces VxFAS operations.
- [Chapter 3. “Using Veritas FlashSnap Agent for Symmetrix with VxVM” on page 33](#), describes how to use the Veritas Volume Manager and the VxFAS commands in an EMC environment.
- [Chapter 4. “Using the Veritas FlashSnap Agent for Symmetrix with VEA” on page 63](#), describes how to perform VxFAS operations from the VERITAS Enterprise Administrator console.
- [Chapter 5. “Troubleshooting” on page 85](#), describes how to recover from common errors encountered while using VxFAS.

## Getting help

For technical assistance, visit <http://support.veritas.com> and select phone or email support. Use the Knowledge Base search feature to access resources such as TechNotes, product alerts, software downloads, hardware compatibility lists, and our customer email notification service.

Diagnostic tools are also available to assist in troubleshooting problems associated with the product. These tools are available on disc or can be downloaded from the Veritas FTP site. See the `README.VRTSspt` file in the `/support` directory for details.

For information on purchasing product documentation, visit <http://webstore.veritas.com>.

## Product message number

If you encounter a product error message, record the unique message number preceding the text of the message. When contacting Symantec Technical Support, either by telephone or by visiting the Technical Support website, be sure to provide the relevant message number. Technical Support will use this message number to quickly determine if there are TechNotes or other information available for you.

A unique message number is an alpha-numeric string beginning with the letter “V”. For example, in the message number:

```
V-5-732-8018 At least one disk must be specified
```

the “V” indicates that this is a Symantec product error message. The text of the error message follows the unique message number.

The text of the error message follows the unique message number.



# Veritas FlashSnap Agent for Symmetrix

Veritas FlashSnap Agent for Symmetrix combines the strengths of the Symantec products with specific enhancements to manage EMC *TimeFinder* product. VxFAS comprises the following products:

- Veritas FlashSnap Agent for Symmetrix  
An extension to the EMC Corporation *TimeFinder* product that uses special features within the Veritas File System (VxFS) and Veritas Volume Manager (VxVM).
- Veritas Cluster Server (VCS) Agents for Veritas FlashSnap Agent for Symmetrix.  
An add-on feature to VxFAS to provide high availability.

## Veritas FlashSnap Agent for Symmetrix utilities

EMC *TimeFinder* is a business continuance solution that lets you create and use copies of EMC Symmetrix devices while the standard devices remain online and accessible. Business Continuance Volume (BCV) devices contain copies of Symmetrix standard (STD) devices and provide redundancy. You can temporarily detach BCV mirrors and use the BCVs to perform backups, testing, and other administrative tasks.

VxFAS is a set of commands that allow you to use EMC *TimeFinder* in conjunction with the Veritas Volume Manager. You can use Volume Manager to build disk groups and volumes on Symmetrix STD devices, then use VxFAS on the Volume Manager disk groups. Using VxFAS commands, you can:

- Associate Symmetrix STD devices in a disk group with identical BCV devices.
- Initiate *TimeFinder* mirroring for Symmetrix STD devices in a disk group.
- Split Symmetrix STD devices from their BCV devices and create duplicate volumes on the BCV devices. You can use the resulting BCV volumes for administrative tasks such as backups and testing.
- Reattach and resynchronize the STD and BCV devices. The devices can be remirrored from the STD copy or restored from the BCV copy.
- Detach the STD devices from their BCV devices.

---

**Note:** VxFAS uses SYMCLI internally to perform operations on EMC *Symmetrix* storage arrays. VxFAS also performs validations and rule checks before and after the SYMCLI operations. This slows VxFAS operations compared to SYMCLI operations.

---

## Veritas Cluster Server Agents for Veritas FlashSnap Agent for Symmetrix

Veritas Cluster Server lets you monitor systems and application services, and restart services on a different system when hardware or software fails. Veritas Cluster Server Agents for Veritas FlashSnap Agent for Symmetrix are add-ons to Veritas Cluster Server to enable such high availability for the VxFAS. For a detailed description of this feature, see the VERITAS Cluster Server Agents for VERITAS FlashSnap Agent for Symmetrix Installation and Configuration Guide.

## EMC Symmetrix disk arrays

The EMC Symmetrix disk array is an integrated cached disk array with capabilities such as internal mirroring, RAID-S, and striping. EMC *TimeFinder* supports mirroring of data by associating STD type devices with BCV type devices to establish an STD-BCV pair (mirror). This mirror can later be split and each split device can be used separately for backup, testing, and other applications.

The Symmetrix disk array has various device types, which include:

- Standard/primary device (STD)
- Business Continuance Volume (BCV)
- 2-way mirror (mirror-2), 3-way mirror (mirror-3), 4-way mirror (mirror-4)
- RAID-S
- Remote Data Facility (RDF1, RDF2)

These devices can be combined to create additional configurations, such as STD-mirror-3 and RDF1-RAID-S.

## Device names

Disks in Volume Manager disk groups have two names:

**device name** The physical disk device name (or *disk access name*). This usually takes the form `c#t#d#[s#]`

**disk name** The Volume Manager disk name (or *disk media name*). This is the logical name given to the disk by the Volume Manager or the administrator.

If the EMC PowerPath feature is installed, device names can be in a format other than `c#t#d#[s#]`. Depending on the PowerPath release, device names use one of the following formats:

- `c#t#d#[s#]`
- `emcpower#c`

When using PowerPath, make sure that you specify the correct PowerPath device name format to VxFAS commands.

## EMC rules for Volume Manager

EMC provides Volume Manager with a set of rules to ensure that Volume Manager works correctly with intelligent storage hardware in an EMC environment. Most of the rules optimize the Volume Manager configuration on Symmetrix devices and prevent inappropriate configurations. These rules apply to Volume Manager tasks such as creating a disk group, adding disks to a disk group, and allocating storage for a volume.

The underlying hardware configuration within a Symmetrix disk array may provide a misleading view to Volume Manager. For example, Symmetrix can divide an internal physical disk into two or more parts called *hyper volumes* or *hypers*. Each hyper can participate in setting up a different logical device as a Logical Unit Number (LUN) visible to the host. VxVM and the dynamic multi-pathing (DMP) feature interpret these devices to be two different disks, and you can create a mirrored VxVM volume on these disks. However, this mirrored volume has no redundancy because parts of all the mirrors reside on the single disk shared by the underlying LUNs. The EMC rules provide information that can be used to avoid such situations. There are two types of rules:

- *Alert rules* improve performance and ensure that any new Volume Manager objects are compatible with the FlashSnap Agent for Symmetrix. These rules warn about situations that can result in a configuration with objects that cannot be administered by VxFAS, potential incompatibilities between objects, or performance loss.
- *Prevent rules* try to avoid situations that can cause loss of data protection and availability. These rules help you and Volume Manager prevent inappropriate configurations, such as creating a mirrored volume on Symmetrix devices that are really part of the same physical disk or adding incompatible disks to a disk group.

---

**Note:** The rules are not checked when the disk groups and volumes are created using the VxVM Allocator service.

---

## Disk group rules

This section summarizes the EMC rules that apply to Volume Manager disk groups. Following are the prevent rules:

- Adding CKD, VCMDB (Volume Logix Database), DRV (Dynamic Reallocation) types of Symmetrix devices to a Volume Manager disk group
- Adding a write-disabled (WD) Symmetrix device

These devices cannot be used for I/O operations so should not be added to a VxVM disk group.

The alert rules warn against doing the following:

- Mixing devices of type STD with devices of type BCV in the same Volume Manager disk group.  
 VxFAS cannot operate on a disk group with a mix of STD and BCV devices.
- Mixing devices of type non-RDF with devices of type RDF in the same Volume Manager disk group  
 The RDF and non-RDF type of devices have different types of SRDF protections and hence they cannot be added to the same device group. So VxFAS cannot operate on such a device group.
- Mixing devices of type R1 with devices of type R2 in the same Volume Manager disk group  
 R1 and R2 type of devices cannot be added to the same device group, so VxFAS cannot operate on such device groups.
- Mixing RDF devices from different RA groups in the same Volume Manager disk group  
 Devices from different RA groups cannot be grouped, so VxFAS cannot operate on such device groups.
- Adding Symmetrix and other storage type devices to a Volume Manager disk group

- Adding gatekeeper devices, as defined through the SYMAPI library, to a Volume Manager disk group  
EMC recommends not using gatekeeper devices for I/O operations.
- Removing devices that were attached using VxFAS commands from a disk group. See “[Attaching devices](#)” on page 41.  
Removing an attached device from a disk group invalidates the VxFAS attachments and prevent restore or remirror with the corresponding disk group.
- Destroying a disk group that contains devices that were attached using VxFAS commands  
If you destroy a disk group having valid attachments while it is established with another disk group, then you will not be able to split it using VxFAS. If the disk group was not established, then the device group and stale pairing information stay in the Symmetrix database. This may cause unexpected behavior if you try to use the devices from the deleted disk group in further operations without a proper cleanup and a complete array rescan operation. See “[To perform array rescan operation:](#)” on page 16 for more information on array rescan operation.

## Volume rules

This section summarizes the EMC rules that apply to Volume Manager volumes.

- The subdisks of a plex cannot reside on multiple device types, such as a combination of Symmetrix and other devices or Symmetrix devices of different protection levels.
- A column of a striped or RAID-5 plex cannot reside on the same Symmetrix back-end device as another column of the plex.  
Breaking this rule introduces a single point of failure (same back-end device) in the Volume Manager configuration.
- A column of a striped or RAID-5 plex on a Symmetrix disk must be based on a different RAID group from another column of the plex.
- The subdisks of a mirror cannot reside on the same Symmetrix back-end device as any other subdisk of another mirror.  
Breaking this rule introduces a single point of failure (same back-end device) in the Volume Manager configuration.
- If one subdisk of a plex resides on a PowerPath parent device, all other subdisks of the same plex must also reside on PowerPath parent devices.
- If one subdisk of a plex resides on an RDF device, all subdisks of the plex must reside on RDF devices with the same RA number.
- The stripe size for a striped or RAID-5 plex must be 128K.

The volume rules apply while creating the volume using the `vxassist` command, resizing the volume using `vxassist` or `vxresize` commands, or mirroring the volume using `vxassist` or `vxmirror` commands.

## Unenforced rules

The EMC rules for volumes are not enforced in the following situations:

- For layered volumes. In an EMC environment, VxVM cannot create layered volumes with `vxassist make|convert` command.
- The `vxassist` command does not support layered volumes in an EMC environment. If you change the layout of a volume, the resulting volume does not comply with EMC rules, and there is no way to salvage the original volume.
- With the `-o override` option.
- The Volume Manager hot-relocation feature is disabled in an EMC environment.

## Task roadmap

This section summarizes Volume Manager and FlashSnap Agent for Symmetrix tasks. The tasks are grouped into required setup tasks and optional maintenance tasks. The procedures for these tasks are included in later chapters. To perform these tasks at the command line, go to [“Using Veritas FlashSnap Agent for Symmetrix with VxVM”](#) on page 33. To perform these tasks using the Veritas Enterprise Administrator, go to [“Using the Veritas FlashSnap Agent for Symmetrix with VEA”](#) on page 63.

### Setup tasks (required)

**To install and set up the FlashSnap Agent for Symmetrix:**

Install the FlashSnap Agent for Symmetrix package (`VRTSfas`). See the *Veritas Storage Foundation Installation Guide* and the *Veritas FlashSnap Agent for Symmetrix Release Notes*.

**To perform array rescan operation:**

VxFAS uses the agent framework provided by the Veritas Enterprise Administrator service. When StorageAgent starts, VxFAS initiates discovery (array rescan) of the local Symmetrix arrays attached to the host. It collects the configuration information about the local Symmetrix arrays and updates the agent database. This database is then used and updated in subsequent VxFAS operations.

Before executing any VxFAS operation, ensure there is no rescan operation in progress on the array or the VxFAS operation will fail.

---

**Note:** It is important that at least one successful rescan was performed on the given array before any VxFAS operation is run.

---

The array rescan operation is invoked automatically after the StorageAgent starts and runs periodically depending on the interval configured. The default interval is 24 hours. The array rescan can also be invoked manually whenever needed. See [“Configuring options for EMC Symmetrix arrays in the StorageAgent”](#) on page 65 for more information on how to modify the default interval and invoke array rescan manually.

To determine if a rescan operation is in progress on an array, look for the **Discovering EMC Symmetrix Arrays** task in the VEA console task pane.

It is advisable to perform the array rescan immediately after configuration changes are made using tools other than VxFAS utilities. For example, if you change the state of some BCV devices from NR to RW using SYMCLI, you should



start the rescan operation on that array. This ensures that the agent database contains the correct and latest configuration information about those devices.

---

**Note:** Changing an array configuration using external tools (such as SYMCLI) and not performing a rescan on the array invalidates the configuration information in the agent database. This may cause the VxFAS commands to fail unexpectedly.

---

**To set up devices and volumes:**

- 1 Add devices to Volume Manager. Create a disk group (if necessary) and add STD devices to the disk group.
- 2 Create volumes in the disk group that contains STD devices.
- 3 Scan devices to update the Symmetrix configuration information.
- 4 Attach Symmetrix STD devices to BCV devices to create STD-BCV pairs through disk group or device pair operations.
- 5 Mirror the STD devices to BCV devices. This initiates *TimeFinder* mirroring for the devices. An optional secondary disk group (BCV disk group) name can be specified with which STD devices are synchronized. If no name is specified, the currently attached BCV disk group is taken as default.

## Administrative tasks (optional)

### To use BCV mirrors for administrative tasks

- 1 Split the STD-BCV disk group pairs. This temporarily splits the BCV devices from the STD devices and creates a disk group with duplicate volumes on the BCV devices. Up to 16 such BCV disk groups can be created through a series of attach, mirror and split operations on the STD disk groups with different BCV disk groups, one at a time. This allows up to 16 BCV devices associated to each STD device in an STD disk group, but at a time only one BCV device can be in synchronization with the STD device in the disk group. Split operation allows the user to specify the name of the BCV disk group to be created after split operation in the command line. If the user does not specify the BCV disk group name, a default BCV disk group name is selected.
- 2 Use the split BCV disk groups for administrative tasks such as backups and testing.

### Resynchronize STD and BCV devices

After splitting the STD-BCV disk group, the STD and BCV devices can be resynchronized. There are two ways to do resynchronization:

- **Mirror.** This operation can be used on the STD-BCV disk group pair after the BCV disk group is no longer needed for administrative tasks and you want the BCV disk group to be synchronized with the STD disk group. This copies data from the STD devices in the STD disk group to the BCV devices in the BCV disk group.
- **Restore.** This operation can be used on the STD-BCV disk group pair when you want to replace the contents of the STD devices in the disk group with the contents of the BCV devices in a BCV disk group. This may be necessary if the data on the STD devices is corrupted. This copies data from the BCV devices to the STD devices.

There are two ways of specifying the BCV disk group with which the STD disk group can be resynchronized:

- **Reattach.** The `vxsymsetup reattach` command reattaches the STD disk group with one of the previously associated BCV disk groups.
- **Specifying the BCV disk group in resynchronization commands** (that is, in mirror or restore commands).

### To detach an STD-BCV pair

- 1 Split the STD-BCV device pairs. This splits the BCV devices from the STD devices and creates a disk group with duplicate volumes on the BCV devices.
- 2 Detach the STD devices from the BCV devices. This breaks the connection between the STD and BCV devices.
- 3 Use `detachall` to detach all the attached BCV devices from the STD devices. This breaks the attachment and association between the STD and all the associated BCV devices corresponding to the STD disk group.
- 4 The `detach` and `detachall` operations can be done on a disk group. `detach` breaks the attachment and association between the STD and BCV devices of the corresponding disk groups. If `detachall` is specified, all the attached BCV devices from the STD devices of the specified STD disk group are detached. See “[Detaching devices](#)” on page 53.

### To monitor objects

- Use Veritas Enterprise Administrator to view information about Volume Manager objects and Symmetrix devices.
- Use the `vxprint` or `vxsymquery` commands to view information about Volume Manager objects. See “[Viewing device information](#)” on page 56.

### Enable VxFAS trace messages

VxFAS operations write trace messages to the StorageAgent log file `/etc/vx/isis/StorageAgent/StorageAgent.log`. This log is useful when trying to identify a VxFAS problem. By default, only critical trace messages are logged. You can increase the level of tracing if you think that a VxFAS operation is behaving erroneously or is giving unexpected results. To increase the level of trace messages for VxFAS, enter:

```
# vxregctl /etc/vx/isis/Registry setvalue \  
  
Software/VERITAS/VRTSobc/pal33/Agents/StorageAgent/Providers/vx_emsymmetrix \  
TRACELEVEL REG_INT 3  
  
# vxregctl /etc/vx/isis/Registry setvalue \  
  
Software/VERITAS/VRTSobc/pal33/Agents/StorageAgent/Providers/vxtf \  
TRACELEVEL REG_INT 3
```

The TRACELEVEL attribute value can be set from 0 to 6, where 0 indicates all possible trace messages. Setting the TRACELEVEL attribute to 0 increases the log file size considerably.



# Introduction to Veritas FlashSnap Agent for Symmetrix

This chapter explains how to perform the various tasks on the Veritas FlashSnap Agent for Symmetrix (VxFAS). These tasks include mirroring the Business Continuance Volumes (BCV) with the standard device (STD), splitting the STD-BCV pairs, creating usable volumes on the BCV devices, and remirroring or restoring the primary devices from the corresponding BCV devices.

## Business continuance processes

BCVs are Symmetrix devices that are specially configured in Symmetrix to be dynamic mirrors. After BCVs are created, they can be split from their production mirrored volumes and used for loading data warehouses, testing new applications, running batch jobs, making backups, and other functions that typically disrupt normal business support. BCVs can also be used to restore the environment following testing or system changes, and can be locally mirrored (RAID-1) for additional protection.

Each BCV device has its own host address and is configured as a standalone Symmetrix device. The Veritas FlashSnap Agent for Symmetrix business continuance sequence is initiated and controlled from a single host. This sequence involves three processes:

- Setting, or establishing, a BCV as an additional mirror of a VxVM volume within a disk group.

- After the BCVs are established as a mirror of the disk group, the BCV disk group can be separated, or split, from the standard Symmetrix disk group with which it was previously paired.  
 At this point, the BCV disk group has valid data and is available for backup or other host processes through the new volumes. A different set of BCVs can then be attached, mirrored, and split with the same set of STD disks to get a different point-in-time copy of the data in the STD disk group. This way up to 16 snapshots can be created for an STD, but only one BCV can be in an established state with the STD at a time.
- After host processes on the BCV disk group volumes are complete, the BCV disk group can again be mirrored to the standard Symmetrix disk group to acquire new data for other business continuance processes or to update the standard volume with the data from the completed business continuance processes.

## VxFAS components

The main components of Veritas FlashSnap Agent for Symmetrix are:

- Standard devices and standard device mirrors
- BCV devices and mirrors
- VxVM Disk Groups, Volumes, and VxFS File Systems

BCV devices and Standard devices reside in the same cabinet.

standard devices	Standard Symmetrix devices are configured for typical Symmetrix operation under a designated protection method, such as RAID-1, RAID-S, SRDF. The standard device can have any mirror structure (RAID-1, RAID-S, or RAID with SRDF). There can be up to three mirrors because establishing a BCV pair requires assigning the BCV device as the next available mirror of the standard device. Symmetrix standard devices can be used as VxVM disks and included in VxVM disk groups. Non-Symmetrix disks are ignored during Veritas FlashSnap Agent for Symmetrix operations.
BCV devices	A BCV device is a standard Symmetrix device for dynamic mirroring. A BCV device has additional attributes that allow it to independently support host applications and processes. A BCV device can be RAID-1 or SRDF protected, but not RAID-S protected.
mirrors	After a BCV device is established as a mirror of a standard device, the two devices together constitute a <i>BCV pair</i> . The pair is comprised of two types of mirrors: the standard device mirrors and the BCV mirror.

standard device mirrors	Each mirror contains a copy of the data contained in the standard device. There can be up to three standard device mirrors.
BCV mirrors	A BCV mirror is a standard mirror (one of M2, M3, or M4) that is assigned upon creation of the BCV pair.
VM Disk Groups	Symmetrix devices can be used as VM disks and included in VxVM disk groups, volumes, and VxFS file systems. While Symmetrix internal <i>TimeFinder</i> operations are performed at the device level, VxFAS provides the necessary logical mapping and control functions to allow <i>TimeFinder</i> operations to be carried out at the disk group level.
Snapshots of STD disk group	A BCV mirror can be split with the STD disk group to create a snapshot of the STD disk group. This process creates a BCV disk group that is an exact copy of the STD disk group.

## VxFAS operations

Veritas FlashSnap Agent for Symmetrix is used to provide a foundation for various host business continuance processes. The following operations are available through host commands described in this guide.

### Establish

The command `vxsymmir` assigns the BCV disk group as a mirror of a standard disk group and copies the entire contents of the standard disk group to the BCV disk group. The following figure illustrates the initial Symmetrix configuration prior to performing any *TimeFinder* operation.

**Figure 2-1** Symmetrix Configuration Prior to *TimeFinder* Operations

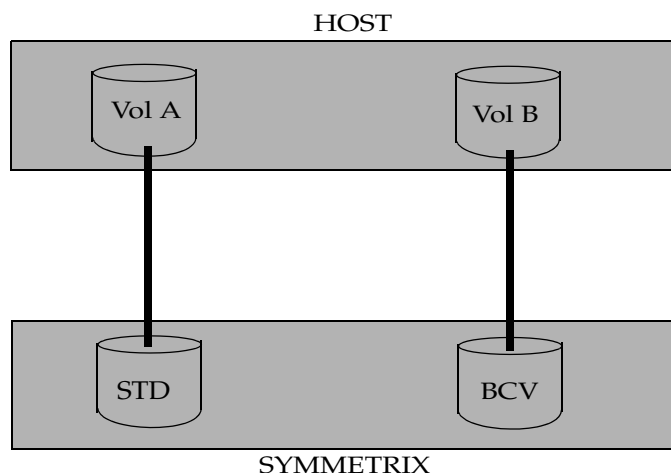

To obtain a copy of the data on a standard Symmetrix disk group, a BCV disk group association must be created. A BCV disk group association consists of BCV devices and standard devices that make up the volumes in the VxVM disk group. The standard devices within a disk group can have up to three mirrors. The mirror structure can be normal, RAID-1, or RAID-S with SRDF. This constraint is because establishing a BCV pair requires assigning the BCV disk group as the next available mirror of the Standard disk group. Because there is a maximum of four mirrors allowed per disk group in the Symmetrix, a disk group already having four mirrors is not able to accommodate another one.

The `vxsymmir` command determines the standard Symmetrix devices and BCV devices corresponding to VxVM volumes in the specified VxVM disk group, and issues the appropriate Symmetrix interface commands to establish the BCV disk



group as a mirror of the standard disk group. The following figure shows a BCV pair being established after a `vxsymmir` command.

**Figure 2-2** Symmetrix Configuration During an Establish Operation

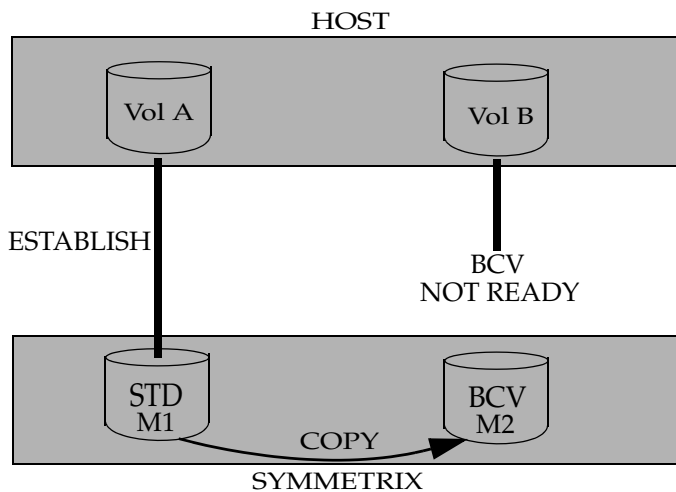

Symmetrix internal functions create the appropriate mirror relationships and copy data from the standard to the BCV devices. The BCV disk group is synchronized when the standard device mirrors and the BCV mirrors contain identical data. To use a BCV disk group for business continuance procedures, the BCV disk group must be split to make the BCV disk group and volumes available to the host.

---

**Note:** The BCV devices are not available for host use during the time that it is assigned as a BCV mirror on a standard device. However, any new data written to the standard device is copied to the BCV device while the BCV pair exists.

---

## Split

After an association is established between the STD and BCV devices, the BCV disk group contains a copy of the data from the STD device. Both devices have identical data until the `vxsysm split` command is issued. The `vxsysm split` operation makes the BCV disk group available to the host. The figure shows the result of the split operation.

**Figure 2-3** Symmetrix Configuration After a Split Operation

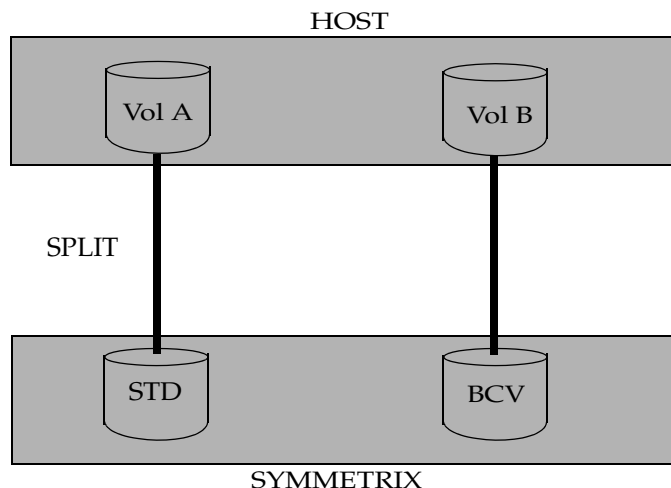

The following operations are carried out by the split operation:

- If the STD disks are mounted on a VxFS file system, I/O to the file system is frozen and buffers are flushed to ensure a consistent point-in-time image on the BCV devices. If a file system other than VxFS is in use, it must be unmounted.
- Devices containing VxVM volumes are split from the STD devices.
- VxFS file systems that were frozen are thawed after the split is complete.
- The new disk group name has the original disk group name prefixed by `bcv`.
- Volumes on the BCV disk group have names identical to the original volume name.
- If the volumes on STD devices are mounted on VxFS file system, the BCV volumes are mounted by default.

Any required operations can be done now. The following options are available:

- Re-establish the BCV disk group (`vxsymmir`)
- Restore data from the BCV disk group to its STD disk (`vxsymrestore`)
- Establish a new pair consisting of the same BCV disk group with a new STD disk group (`vxsymsetup`)
- Attach a new BCV disk group to current STD disk group for taking another snapshot through split operation after mirroring. In this way up to 16 snapshots of the STD disk group at a different instance in time can be taken. All these BCVs are associated with the STD disk

## Re-establish

Re-establishing a BCV disk group involves copying data from the STD disk group to the BCV disk group. The data copied to the BCV disk group is the data that changed while the BCV devices were split. This process overwrites data that changed on the BCV device. This ensures maximum efficiency of the synchronization. This process is useful if the data on the BCV device is not needed or if the current data is needed.

The `vxsymmir` command re-establishes the BCV disk group as a mirror of the STD disk group. The BCV disk group is synchronized when the STD device mirrors and the BCV mirrors contain identical data.

**Figure 2-4** Symmetrix Configuration During a Re-establish Operation

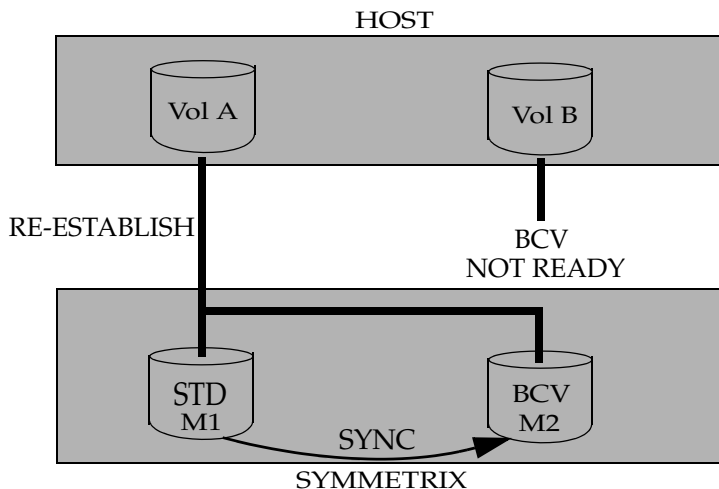

The following functions take place when a `vxsymmir` command is issued:

- The `vxsymmir` command unmounts the VxFS file systems that are mounted on the BCV volumes and are not in use. The command fails if the file system is in use or if a file system other than a VxFS file system is mounted.
- VxVM volumes are removed from the BCV devices.
- The BCV disk group is deported.
- The state of the BCV devices is Not Ready.
- Incremental establish copies data from STD to BCV devices.

The BCV disk group must be split to make the BCVs available to its host.

## Restore

The restore operation copies the entire contents of the BCV disk group to the standard disk group. The `vxsymrestore` command determines the standard Symmetrix devices and BCV devices corresponding to VxVM volumes in the specified VxVM disk group. The `vxsymrestore` command issues the appropriate Symmetrix interface commands to restore the contents of the BCV disk group to the standard disk group.

All applications must be stopped, and all file systems associated with the standard disks must be unmounted, to ensure that access is suspended during this operation.

Symmetrix internal functions create the appropriate mirror relationships and copy data from the BCV devices to the standard devices.

The following functions take place internally when a `vxsymrestore` command is issued:

- Any VxFS file systems that are mounted on the BCV volumes and are not in use are unmounted and the mount point is removed. The command fails if the file system is in use or if a file system other than VxFS is in use.
- VxVM volumes are removed from the BCV devices.
- The private regions of the volumes are copied from the standard devices to the BCV devices.
- Copy data from BCV devices to standard devices.
- The BCV pair is synchronized when the standard device and the BCV device contain identical data. The restoration process is complete when the devices are synchronized.

The restoration process is complete when the standard device and the BCV device contain identical data.

The following figure shows the standard and BCV devices containing identical data after the restoration process is complete.

**Figure 2-5** Symmetrix Configuration During a Restore Operation

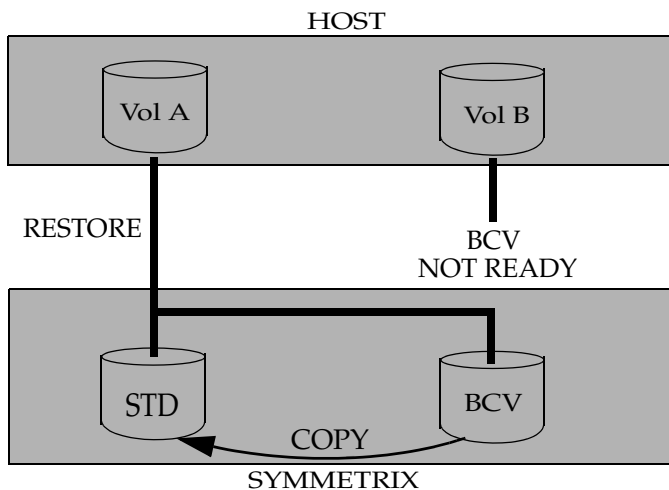

---

**Note:** The device is not available for host use during the time that it is assigned as a BCV mirror on a standard device. However, any new data written to the standard device is copied to the BCV device while the BCV pair exists.

---

The BCV disk group must be split again before it can be used for BC procedures.

## Incremental restore

The incremental restore accomplishes the same thing as the restore process with one time-saving exception: the BCV copies only new data to the standard disk group that was updated on the BCV disk group while the BCVs were split. Any changed tracks on the standard disk group are also overwritten by the data on the corresponding track on the BCV disk group. This maximizes the efficiency of the synchronization process.

This process is useful if the results from running a new application on the BCV disk group were desirable, and you want to port the data and the new application to the standard disk group.

**Figure 2-6** Symmetrix Configuration During an Incremental Restore

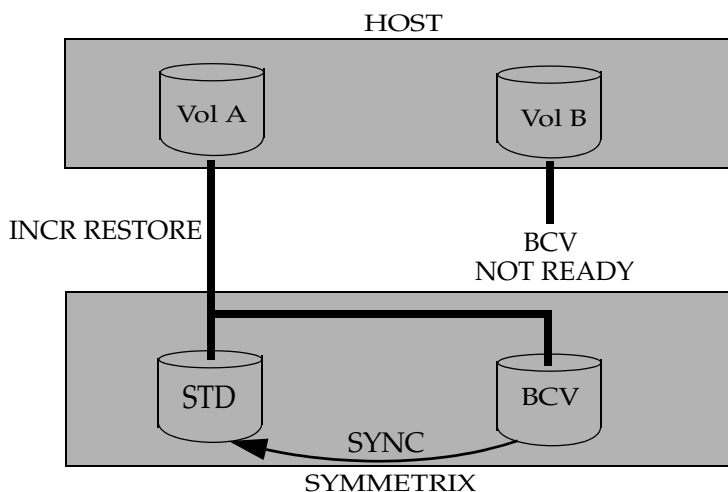

---

**Note:** The `vxsymmir` and `vxsymrestore` commands, by default, perform incremental mirror and incremental restore between the associated STD-BCV disks. To perform full mirror or restore (which is required when the STD-BCV disks are being mirrored or restored for the first time), use the commands with the `-o full` option.

---

## VxFAS features

### Multiple BCV support

Starting from microcode 5266 and SYMAPI 4.1, the Symmetrix maintains track tables for up to 16 BCVs per STD device with only one BCV mirrored at a time. This is a change from the previous versions of microcode where track information about only one BCV was maintained per STD device. Thus VxFAS commands now deal with multiple BCV disk groups for setup, split, remirror, and restore operations. This allows taking up to 16 snapshots of the STD disk group (one at a time) for which incremental mirroring or restore (which is relatively quick because only invalid tracks are updated) operations are possible. Rules for multiple BCV support include:

- Multiple BCV support is at the disk group abstraction level, not the device level.
- Toolkit does not allow successive attaching of multiple BCVs with one STD device before creating the first mirror with the previously attached BCV.
- If an STD-BCV pair is attached, and no subsequent first mirror was created, a reattach of the same STD and different BCV will fail.
- With a file option, you can specify the pairs that show the explicit correspondence between the STD and BCV devices.
- For detaching a STD-BCV pair, the STD must be in split state.
- The `vxsymsetup` command has a disk group reattach option for multiple BCV support.
- Only one BCV device at a time can be in the synched or restored state for an STD device.

### Unix standard command line options

All VxFAS commands follow the UNIX standard command syntax. All commands work at the disk group level. Operations on device pair are supported only for the `attach` and `detach` options of the `vxsymsetup` command.

### **Attachment rules**

VxFAS commands follow the rules below about STD and BCV device attachments in a VxFAS disk group.

### **Control operations only on disk groups**

Because all operations are performed at the disk group level, there must be consistency within a disk group. Therefore VxFAS commands require that all the devices in an STD disk group have an attached BCV. If there is an STD device that does not have a BCV attached, the control operation is aborted and an error message is displayed. Control operations are carried out on the entire STD disk group, not on individual devices in the STD disk group.

### **Commands operate only on VxFAS generated device groups**

VxFAS commands operate only on device groups created by VxFAS commands (`vxsymsetup attach`). Any device group created outside of VxFAS are not supported.

### **Support for moving devices**

Moving a device from a device group to the required device group is done through user prompting and interaction. This is required during the attach operation if the device to be attached is in another device group.

### **Control operations strictly validate device consistency in disk groups and corresponding device groups**

Control operations (`establish/split/restore`) are aborted if devices in the specified disk group do not belong to the device group.



# Using Veritas FlashSnap Agent for Symmetrix with VxVM

This chapter describes how to use the Veritas Volume Manager and the Veritas FlashSnap Agent for Symmetrix commands in an EMC environment. The following topics are discussed in this chapter:

- [Adding devices to VxVM disk group](#)
- [Creating volumes](#)
- [Attaching devices](#)
- [Mirroring disk groups](#)
- [Splitting disk groups](#)
- [Remirroring disk groups](#)
- [Restoring disk groups](#)
- [Reattaching disk groups](#)
- [Detaching devices](#)
- [Recovering crashed commands](#)
- [Viewing device information](#)
- [Disk group reconfiguration](#)
- [Policy setting support for EMC rules for Volume Manager](#)

## Adding devices to VxVM disk group

Before you can use the Volume Manager and the FlashSnap Agent for Symmetrix, you must place the Symmetrix standard (STD) and BCV devices under VxVM control. New disks must be set up on the system, placed under Volume Manager control, and added to a disk group before volumes can be created on these disks.

All VxFAS commands follow the UNIX standard command syntax. All commands work at the disk group level. Device pair operations are supported only for the `attach` and `detach` options of the `vxsymsetup` command.

VxFAS commands require the StorageAgent running. Before running any VxFAS commands, ensure that StorageAgent is available on that host by executing the following command:

```
# /opt/VRTSobc/pa133/bin/vxpalctrl -a StorageAgent -c status
```

If the StorageAgent is not up, start it:

```
# /opt/VRTSdsa/config/startup.sh start
```

## Using EMC PowerPath devices with VxVM

In previous versions of VxVM, it was necessary to perform `powervxvm init` and `powervxvm online` to use EMC PowerPath devices with VxFAS.

In VxVM 4.0 release, the EMC PowerPath devices can be configured as foreign devices (see the `vxddladm(1M)` manual page for more information).

In VxVM 4.1 release, the EMC PowerPath devices can be autodiscovered using the third-party driver (TPD) coexistence feature of VxVM. EMC PowerPath devices can still be configured as foreign devices in VxVM 4.1 for VxFAS.

The following sections describe procedures for using PowerPath *pseudo* (*emcpower*) devices with VxFAS.

## New installation

### Configuring EMC PowerPath devices with foreign device support

If you are not already using EMC PowerPath devices with VxVM, perform the following procedure to put the PowerPath devices under VxVM control as foreign devices:

- 1 Make sure that there are no *emcpower* nodes in `/dev/vx/rdmp` and `/dev/vx/dmp` directories. If they exist, remove them.
- 2 Install EMC PowerPath software.
- 3 Make sure that *emcpower* devices are present in `/dev/rdsk` directory.
- 4 Disable the DMP *Restore daemon*:  

```
# /usr/sbin/vxdmpadm stop restore
```
- 5 Exclude the TPD coexistence support for EMC disk array from VxVM.  

```
# /usr/sbin/vxddladm excludearray libname=libvxemc.so
```
- 6 Configure *emcpower* devices as foreign devices for VxVM:  

```
# /usr/sbin/vxddladm addforeign  
pathname=/dev/rdsk/emcpower*c  
# /usr/sbin/vxddladm addforeign  
pathname=/dev/dsk/emcpower*c
```
- 7 Make the *emcpower* devices visible to VxVM:  

```
# /usr/sbin/vxdisk scandisks
```
- 8 Start the DMP *Restore daemon* that was previously stopped:  

```
# /usr/sbin/vxdmpadm start restore
```
- 9 Restart the StorageAgent.

### Configuring EMC PowerPath devices with TPD coexistence feature

When upgrading a system to VxVM 4.1, an array support library (ASL) provided by Symantec makes information about any available EMC PowerPath devices available to VxVM. Such devices are configured in DMP as autoconfigured disks with DMP nodes. There is no need to configure these devices as foreign devices any more. See the *Veritas Volume Manager Administrator's Guide* for more information about TPD coexistence feature of VxVM.

## Existing installation of EMC PowerPath devices

If you have already configured *emcpower* devices for use with VxVM using *powervxvm* commands, perform the following procedure:

- 1 Remove *emcpower* nodes from `/dev/vx/rdmp` and `/dev/vx/dmp` directories:
 

```
# /etc/powervxvm remove
```
- 2 Disable the DMP Restore daemon:
 

```
# /usr/sbin/vxdmpadm stop restore
```
- 3 Exclude the TPD coexistence support for EMC disk array from VxVM.
 

```
# /usr/sbin/vxddladm excludearray libname=libvxemc.so
```
- 4 Configure *emcpower* devices as foreign devices for VxVM:
 

```
# /usr/sbin/vxddladm addforeign
pathname=/dev/rdisk/emcpower*c
# /usr/sbin/vxddladm addforeign
pathname=/dev/dsk/emcpower*c
```

---

**Note:** Alternatively, you can use the TPD coexistence feature of VxVM 4.1 to use EMC PowerPath devices as autoconfigured disks. See [“Configuring EMC PowerPath devices with TPD coexistence feature”](#) on page 35.

---

- 5 Make the *emcpower* devices visible to VxVM:
 

```
# /usr/sbin/vxdisk scandisks
```
- 6 Start the DMP Restore daemon that was previously stopped:
 

```
# /usr/sbin/vxdmpadm start restore
```

## Using PowerPath native devices

PowerPath native devices can be used by VxVM 4.1 as they are, but you can remove DMP from the I/O path and configure these devices as foreign devices. Refer to *Veritas Volume Manager Administrator's Guide* for more information on foreign device support.

---

**Note:** EMC PowerPath devices must be initialized as simple disks only if they are used as foreign devices. For more information about limitations of foreign devices see *Veritas Volume Manager Administrator's Guide*.

---

## Using VxVM commands

To create a new Volume Manager disk group and add new devices to it, use the `vxldg init` command:

```
vxldg [-o verify|override] init diskgroup
[medianame=]accessname...
```

where *diskgroup* is the Volume Manager disk group. *accessname* is the device name and *medianame* is the Volume Manager disk name.

To add new devices to an existing Volume Manager disk group, use the `vx dg adddisk` command:

```
vx dg -g diskgroup [-o verify|override] adddisk  
[medianame=]accessname
```

For example:

```
# vx dg -g emcdg adddisk c1t1d1s2
```

EMC provides a set of rules to ensure that the Volume Manager operates with intelligent storage in an EMC environment. The `vx dg` command has a `verify` option that checks that the device being added conforms with the EMC rules.

The `verify` option syntax is:

```
vx dg -g diskgroup -o verify adddisk accessname
```

If no EMC rules are broken, `vx dg -o verify` exits silently and without creating any Volume Manager objects. To create the specified objects, repeat the `vx dg` command *without* the `-o verify` option.

If any of the EMC rules are broken, `vx dg -o verify` displays a relevant error message and exits without creating any Volume Manager objects. To force Volume Manager to add or create an object that does not comply with the EMC rules, use the `-o override` option:

```
vx dg -g diskgroup -o override adddisk accessname
```

It is not advisable to override the EMC rules as it can result in severe performance degradation or loss of data redundancy. For more details on the EMC rules, see the “[Overview](#)” on page 7.

See the *Veritas Volume Manager Administrator’s Guide* or the `vx dg(1M)` manual page for details on adding devices to the Volume Manager.

---

## Notes

---

- When a disk is placed under Volume Manager control, the disk is either initialized or encapsulated. Encapsulation preserves existing data on the disk in the form of volumes. Initialization destroys existing data on the disk. Encapsulation is recommended for the root/boot disk and any other disks that contain valuable data. Encapsulation requires a system reboot.
  - Disks that already belong to a disk group cannot be added to another disk group.
  - Disks cannot be added to deported disk groups.
  - The Volume Manager disk name must be unique within the disk group.
  - In an EMC environment, this command may display an error message that indicates that the task or selected disks do not comply with the EMC rules. If you choose to force the Volume Manager to add a disk that does not comply with the EMC rules, the resulting configuration may contain incompatible disks or objects that cannot be administered by VxFAS.
  - In an EMC environment, you cannot mix some device types in a Volume Manager disk group.
  - Encapsulated disks are not supported by VxFAS. Do not encapsulate disks that you plan to include in STD-BCV pairs.
  - For `bootdg`, all VxFAS functions except restore are supported. See the *Veritas Volume Manager Administrator's Guide* or the `vx dg(1M)` manual page for details on how to check the `bootdg`.
  - If the STD devices in a disk group have attachments, the disk group cannot be destroyed. The disk group can be deported.
  - If one or more NR (not ready) devices were made RW (read-write) without using any toolkit command, you may have to run `vx dctl enable` to refresh the correct state of the device in VxVM. To check the state of a device (NR or RW), run the `sympd list` command.
  - VxFAS supports disk group names containing alphanumeric characters, hyphen (-) and underscore (\_) only.
  - VxFAS does not support CVM shared disk groups, VxVM SAN disk groups, or disk groups containing VVR replicated volume groups (RVGs).
  - VxFAS supports snapshot operations on CDS type of disk groups. CDS is a license-enabled feature of VxVM and is applied at the disk group level. A CDS disk group is composed only of CDS disks (that is, disks with the VxVM disk format `cdsdisk`) and its `cds` attribute set to `on`.
-

## Creating volumes

After the STD devices are added into a disk group, you can create volumes on the STD devices. To create volumes, use the `vxassist` command:

```
vxassist -g diskgroup [-o verify|override] make volume_name |  
length  
[attribute...]
```

Example:

```
vxassist -g emcdg make volemc 50m
```

The `vxassist` command has a `verify` option that checks whether the volume being created or changed conforms to the EMC rules. Use the `verify` option as follows:

```
vxassist -g diskgroup -o verify make volume_name length  
[attribute...]
```

If no EMC rules are broken, `vxassist -o verify` exits silently and without creating any Volume Manager objects. To create the specified objects, repeat the `vxassist` command *without* the `-o verify` option.

If any of the EMC rules are broken, `vxassist` displays a relevant error message and exits without creating any Volume Manager objects. If you want to force the Volume Manager to add or create an object that does not comply with the EMC rules, use the `-o override` option:

```
vxassist -g diskgroup -o override make volume_name length  
[attribute...]
```

Overriding the EMC rules is not recommended as it can result in a configuration with objects that are incompatible or objects that cannot be administered by VxFAS, or cause performance degradation and loss of data redundancy.

For more details on the EMC rules, see [“EMC rules for Volume Manager”](#) on page 12. See the *Veritas Volume Manager Administrator’s Guide* or the `vxassist(1M)` manual page for details on creating volumes.

---

## Notes

---

- The volume size must be less than or equal to the available free space on the disks.
- A striped volume requires at least two disks.
- If no disks are specified in the command, Volume Manager uses the available space on disks in the specified disk group.
- A mirrored volume requires at least two disks. If logging is enabled, the volume requires at least one additional disk.
- The data in a concatenated or striped volume is not protected against disk failure unless the volume is mirrored. At least one additional disk is required to mirror a volume.
- In an EMC environment, this task may display an error message that indicates that the task or specified disks do not comply with the EMC rules. If you choose to force the Volume Manager to create a volume that does not comply with the EMC rules, you may not be able to use VxFAS to administer the resulting volume.
- EMC rules are enforced when a volume is resized. Volumes resized using the `vxassist growto|growby` command have to comply with EMC rules.
- `vxassist` does not support layered volumes in an EMC environment, VxVM cannot create layered volumes with the `vxassist make|convert` command. If you change the layout of a volume, the resulting volume may not comply with EMC rules and there is no way to salvage the original volume.
- A stripe size of 128 KB or its multiple is recommended for striped and RAID-5 volumes in an EMC environment. You can modify the `/etc/default/vxassist` file to ensure a default stripe size of 128 kilobytes. Add the following line to the file:

```
stwidth=128kb
```

---



## Attaching devices

The `vxsymsetup` command sets up the pairing information for STD and BCV devices. This command must be run before you run any other VxFAS commands. The `vxsymsetup` command attaches an STD device to a BCV device to create an STD-BCV pair (or *attachment*). You can move devices from a device group to the required group.

There are various ways of specifying multiple STD-BCV pairs for `vxsymsetup` command to make using the `attach/detach` options easier. These options are:

- Specifying disk groups (`-g PriDg:SecDg`). Only one pair of disk group is allowed.
- Specifying multiple pairs with a file name (`-o filename=filename`)
- Specifying multiple pairs of devices separated by a comma(,) with individual STD-BCV device names separated by colon(:).

To attach an STD device to a BCV device, use the following commands:

```
vxsymsetup -g PriDg [-o enclosure_sno=Symmetrix-id] \
-s PriDev:SecDev[,PriDev:SecDev,...] [-n]
attach
vxsymsetup -g PriDg [-o enclosure_sno=Symmetrix-id] \
-o filename=file [-n] attach
vxsymsetup -g PriDg:SecDg [-n] attach
```

where:

*PriDg* is the VxVM disk group to which the STD devices currently belong.

*SecDg* is the VxVM disk group to which the BCV devices currently belong.

*Symmetrix-id* is the Symmetrix serial ID of STD/BCV devices.

*PriDev* and *SecDev* are STD and BCV device names. If the `-o enclosure_sno` option is specified, use Symmetrix device names. Without the `-o enclosure_sno` option, use VxVM disk access name.

*file* is the file containing device pairs.

### Examples

```
vxsymsetup -g emcdg -s c0t0d0s2:c0t6d0s2 attach

vxsymsetup -g emcdg -o enclosure_sno=000111222333 \
-s 012:0A8 attach

vxsymsetup -g emcdg:bcvdg attach

vxsymsetup -g emcdg -o filename=file attach
```

The entries in the file will be:

```
#STD          #BCV
c0t0d0s2     c0t6d0s2
```

or this when `enclosure_sno` is specified:

<code>#STD</code>	<code>#BCV</code>
<code>012</code>	<code>0A8</code>

After setting up an STD-BCV pair, mirror the device pair (see “[Mirroring disk groups](#)” on page 43) before you perform any of the following VxFAS tasks:

- Split
- Resynchronization
- Restore
- Reattach

---

### Notes

- The specified STD device must belong to a disk group containing only STD devices.
  - The specified STD and BCV devices must have compatible device types.
  - The specified STD and BCV devices must have identical capacities.
  - The specified STD and BCV devices must belong to same Symmetrix.
  - Encapsulated disks are not supported by VxFAS. Avoid using encapsulated disks to set up an STD-BCV pair.
  - `bootdg` can be used for all operations except restore.
  - The disk group attach operation may not find a pairing solution, even if one exists, because no backtracking is done while finding pairs.
-

## Mirroring disk groups

The `vxsymmir` command mirrors STD devices in a disk group. This command initiates *TimeFinder* mirroring for the Symmetrix STD devices that correspond to the specified disk group. The STD devices are mirrored to Symmetrix BCV devices. Use the `vxsymmir` command with `-o full` option to mirror Symmetrix STD devices for the first time with the selected BCV devices. To mirror Symmetrix STD devices, use the following command:

```
vxsymmir -g PriDg[:SecDg] [-n] [-o full] [-o wait]
```

where:

*PriDg* is the VxVM disk group to which the STD devices currently belong.

*SecDg* is the VxVM disk group to which the BCV devices currently belong and it is associated with *PriDg*.

With multiple BCV support, you can associate up to 16 secondary disk groups with the primary disk group. If the secondary disk group is not specified, the primary disk group is mirrored to the currently attached secondary disk group. If the secondary disk group is specified, the primary disk group is mirrored to the specified secondary disk group.

All of the disks in the specified disk group are mirrored. The `-n` option runs the command without a confirmation request. If the `-o full` option is not specified, the incremental mirror is created. If the `-o wait` option is specified, the command waits until all devices are synchronized.

### Examples

```
vxsymmir -g emcdg -o full
```

While Symmetrix devices are being mirrored, do not perform any tasks on them until the process completes. This command may fail if a synchronization or split operation is in progress on one of the devices.

If the mirroring is being created for the first time with the BCV devices, and the `-o full` option is not specified, a message is displayed informing the user that incremental mirroring is not possible.

After the initial mirroring completes, you must split the device pair before performing any other (see [“Splitting disk groups”](#) on page 44).

---

### Notes

- This task copies all data from a Symmetrix STD device to a BCV device.
  - All the STD devices in the specified disk group must be paired with BCV devices.
  - This task may take several minutes to complete.
-

## Splitting disk groups

After you have mirrored the STD devices to BCV devices, you can split the BCV devices from the STD devices, then use the BCV devices for administrative tasks, such as backups and testing, while the STD devices remain online.

The `vxsysmsplit` command splits a Symmetrix STD-BCV pair and creates a new disk group on the BCV devices. The `vxsysmsplit` also creates a set of volumes (that are identical to the STD volumes and have the same names) in the BCV disk group. The new BCV volumes are visible to VxVM and are available to applications. The BCV disk group is referred to as the *alternate disk group* and its volumes are referred to as *alternate volumes*.

Microcode 5x66 supports *instasplit*. This feature returns the command quickly while continuing the operation in the background. The `vxsysmsplit` command supports this feature through `-o type=instant` option. The `vxsymmir` or `vxsymrestore` commands fail if a background split is in progress for any associated STD or BCV device on which a mirror or restore operation is executed. The `vxsysmsplit` command also supports the differential split feature using the `-o type=diff` option.

To split an STD-BCV disk group, use the following commands:

```
vxsysmsplit -g PriDg[:SecDg] [-o wait] [-n] \  
    [-t timeout] [-o type=split-type] [-F FSType] \  
    [-m snapshot_mount_point] [-o ro|rw|nm] \  
vxsysmsplit -o filename=file [-o wait] [-n] [-t timeout] \  
    [-o type=split-type] [-F FSType]
```

where:

*PriDg* is the VxVM disk group to which the STD devices currently belong.

*SecDg* is the VxVM disk group created after the `vxsysmsplit` completes, to which the BCV devices belong.

The `vxsysmsplit` operation splits all the Symmetrix STD devices that belong to the specified disk group from their BCV devices. The name of the secondary disk group created after the split operation is determined by the argument *SecDg*. When the secondary disk group name is not specified, a default name is selected. The format of this default name is *bcvPriDg[n]*, where  $n=m+1$  such that  $m$  is the largest positive integer with *bcvPriDg[m]* being an imported VxVM disk group.

For example, if the *PriDg* name is *emcdg*, the default name for the secondary disk group will be one of the following:

```
bcvemcdg  
bcvemcdg1  
bcvemcdg2  
...
```

The `-n` option runs the command without a confirmation.

The `vxsysmsplit` operation creates all the VxVM objects that are in the primary disk group in the secondary disk group using the same names. If any VxFS file systems are mounted on the primary VxVM volumes, `vxsysmsplit` mounts VxFS file systems on the corresponding secondary VxVM volumes. The default BCV mount point directory is `/name_of_the_BCV_dg[n]`, where `n` is the lowest available positive integer such that the directory name `name_of_the_BCV_dg_n` does not exist. If the `-m` option is specified, instead of the default mount point, all the VxFS file systems on the secondary VxVM volumes are mounted under the specified mount point. The specified mount point must satisfy following conditions:

- Absolute path name must be specified
- If the path name already exists, it must be a directory
- If the path name does not already exist, it must be possible to create a directory with that name.

The `-o mount_options` option specifies the mount options for the BCV file systems. If `-o nm` option is specified, VxFS file systems will not be mounted on BCV volumes and `-m` option is ignored. The `rw` (read write) option is the default mount option for the file systems.

The `-F` option is used if the VxFS file system is mounted on STD volumes. If this option is not specified and a VxFS file system on an STD is mounted, `vxsysmsplit` exits with an error message. The `vxsysmsplit` operation rejects the `mount` and `timeout` options if `-F` is not specified.

The `-t` option specifies the file system freeze timeout in seconds. This is the total timeout value (for all STD-BCV pairs). If the timeout value is not specified on the command line, `vxsysmsplit` checks the environment variable `VXFS_FREEZE_TIMEOUT`. If this variable is set to a positive integer, `vxsysmsplit` uses this value. If the timeout is not specified on the command line or with the environment variable, `vxsysmsplit` calculates and uses the default timeout value: 14 seconds multiplied by the number of STD-BCV pairs.

The `-o type=split-type` option is specified, the split is one of the supported split types: `diff` (for differential) or `instant`. The `diff` split type performs a differential (or incremental) synchronization between the first mirror of the BCV devices involved in the operation and their additional mirrors (local or remote). This option can only be used if the Symmetrix Differential Data Facility (SDDF) is enabled in the Symmetrix disk array (see the Symmetrix array documentation from EMC for more information). The `instant` split type performs a quick foreground split at the director ports while continuing the actual split in the background.

---

**Note:** *Instasplit* is a new feature in microcode 5x66 for split operations. *Instasplit* makes the split command return quickly while continuing the operation in the background. The `vxsymmir/vxsymrestore` commands fail if the background split is in progress for any associated STD or BCV device on which the mirror/restore operation is executed. The `vxsymquery` command reports status for a background *instasplit* in progress for a set of devices.

---

### Example

```
vxsymsplit -g emcdg:bcvdg
```

This creates a disk group named `bcvdg` on BCV devices. The volumes in the `emcdg` disk group are duplicated in the `bcvdg` disk group with the same names. After a split is performed on the STD-BCV device pair, the devices can be remirrored (see “[Remirroring disk groups](#)” on page 47), restored (see “[Restoring disk groups](#)” on page 49), or detached (see “[Detaching devices](#)” on page 53).

---

### Notes

---

- All of the devices involved in this task must be in the synchronized or restored state.
  - If more than one disk is found with duplicate disk IDs, Volume Manager chooses the disk for the disk group using the following rules:
    - Import the first non-NR-non-WD STD disk, ignore all BCVs
    - If no STD disk is found then import the first non-NR-non-WD BCV
  - This task may take a few minutes to complete.
  - If `instant split` is specified, followed immediately by an incremental establish operation, the split will fail with a “background split is in progress” message. An incremental `restore` operation will succeed.
-

## Remirroring disk groups

After using the BCV devices for administrative tasks, you can remirror the STD devices to the BCV devices. This reattaches and resynchronizes the STD and BCV devices. The data is incrementally copied from the STD devices to the BCV devices.

The `vxsymremir` command or (`vxsymmir` without the `-o full`) option remirrors Symmetrix STD devices in a disk group. This command also removes the alternate volumes created by the `vxsymsplit` command. Use the `vxsymremirk` or `vxsymmir` command to mirror Symmetrix devices that were previously mirrored and split.

To remirror Symmetrix devices, use any of the following commands:

```
vxsymremir -g PriDg [-n] [-o wait]
vxsymmir -g PriDg[:SecDg] [-n] [-o wait]
```

where:

*PriDg* is the VxVM disk group to which the STD device currently belongs.

*SecDg* is the VxVM disk group to which the BCV device currently belongs.

The `-n` option runs the command without a confirmation request.

The `vxsymremir` or `vxsymmir` commands unmount any VxFS file systems that are not in use and are mounted on VxVM volumes on the secondary disk group, then removes the mount points. If the volumes with mounted VxFS file systems are in use, the file systems are not unmounted and `vxsymremir` or `vxsymmir` aborts with an error message. If this happens, use the `fuser -ck` command to kill the processes that use these mount points (but do not unmount the file system). Then run the command again.

The remirror command tries to remove all VxVM objects from the BCV devices that are paired with the STD devices underlying the volumes in the specified disk group. After the objects are removed, the devices are removed from the BCV disk group, the BCV disk group is deported, and the Symmetrix mirror operation is initiated.

If you proceed with the remirror task, any changes in the BCV disk group are lost.

### Examples

```
vxsymremir -g emcdg
vxsymmir -g emcdg
```

If you intend to back up the remirrored data, you must split the devices first (see [“Splitting disk groups”](#) on page 44).

---

### Notes

---

- This task removes all Volume Manager objects from the BCV devices.
  - This task incrementally copies data from STD devices to BCV devices.
  - All of the devices involved in this task must be in the split state.
  - The STD devices in the specified disk group must be paired with BCV devices.
  - Before running this task, unmount any file systems (other than VxFS file systems) that are mounted on volumes on BCV devices and stop any I/O to BCV devices.
  - BCV devices must not be active when the `vxsymremir` or `vxsymmir` command is invoked.
  - The `vxsymremir` command is supported in this release only for backward compatibility and will not be supported in the next VxFAS release. Use the `vxsymmir` command for incremental mirroring.
-



## Restoring disk groups

If you want to replace the contents of the STD devices with the contents of the BCV devices, you can restore the STD devices from the BCV devices. This may be necessary if data on the STD devices is damaged. The data is incrementally copied from the BCV device to the STD device.

The `vxsymrestore` command restores data from the secondary VxVM disk group to the primary VxVM disk group. If `-o full` or `-R` option is specified, all tracks from the BCV devices are copied to the STD devices. Without these options only the changed tracks are copied. The corresponding BCV devices must be defined previously by the `vxsymsetup` command.

To restore Symmetrix devices, use the following command:

```
vxsymrestore -g PriDg[:SecDg] [-nR] [-o wait] [-o full] [-o config]
```

The disk group containing STD devices is referred to as primary disk group (*PriDg*). The disk group containing BCV devices is referred to as secondary disk group (*SecDg*).

If the secondary disk group is not specified, the disk group containing BCV disks that are currently attached to the STD disks is selected as the secondary disk group.

The `vxsymrestore` command fails if file systems are mounted on the STD volumes. In this case, unmount the STD file systems and run `vxsymrestore` again.

The `vxsymrestore` unmounts any file systems that are not in use and are mounted on the BCV volumes. The mount points are removed. If the file systems are mounted and are in use, `vxsymrestore` does not unmount them and aborts the operation with an error message.

If the mount points are in use, identify the processes using the `fuser -c` command. Close these applications or kill the processes if required. It is not necessary to unmount the file system on the BCV disk group. Run the `vxsymrestore` command.

The `vxsymrestore` command restores the configuration of the secondary disk group to the primary disk group; the previous configuration of the primary disk group is overwritten.

If the `-o config` option is specified, `vxsymrestore` restores the VxVM disk group configuration from the secondary disk group to the primary disk group. This option is included only for backward compatibility. This is the default behavior.

The `-n` option runs the command without a confirmation request.

### Example

```
vxsymrestore -g PriDg:SecDg
```

If you intend to use the BCV disk group, previously restored with STD disk group, you must split the disk groups first (see “[Splitting disk groups](#)” on page 44).

---

## Notes

---

- This task restores data from BCV devices to STD devices.
  - All of the devices in a disk group involved in this task must be in the split state.
  - Before running this task, unmount any file systems that are mounted on the STD disk group and stop any I/O to the BCV and STD devices.
  - BCV devices must not be in active use when the `vxsymrestore` command is invoked.
  - Both the primary and secondary VxVM disk groups are deported before the restore starts. None of the disks participating in the operation can be used while the restore operation is in progress.
  - The `vxsymrestore` command is not supported on the `bootdg`.
  - The `vxsymrestore` command waits until the restore operation is completed if the `-o wait` option is specified. This process may take more time depending on the number of invalid tracks. The `vxsymquery` command displays the restoration status.
  - Options `-R` and `-o config` are supported in this release only for backward compatibility and will not be supported in the next VxFAS release.
-

## Reattaching disk groups

The `vxsymsetup reattach` command attaches BCV devices to STD devices that were earlier mirrored and then split.

The secondary disk group must have been previously split from the primary disk group.

To reattach an STD disk group and BCV disk group use the following command:

```
vxsymsetup -g PriDg:SecDg [-n] reattach
```

---

### Notes

---

- All the devices in each of the primary disk groups and the secondary disk groups must be of the same type: REGULAR, RDF1, or RDF2.
  - All the devices in each of the primary disk groups and the secondary disk groups must be in the same state.
  - The operation succeeds if for every STD device in the primary disk group, there is a BCV device to which it can reattach.
-

## Detaching devices

The `vxsymsetup detach` command detaches a Symmetrix STD device from a BCV device. An STD-BCV pair must be detached before a disk is moved from one VxVM disk group to another.

The `vxsymsetup detach` command removes the pairing information previously set by the `vxsymsetup attach` command. If the disk group pair is specified, the command finds the STD-BCV pairs and detaches them. If a device pair is specified, detach is performed only for that device pair. After being detached, the pair cannot be incrementally mirrored or incrementally restored.

For detach operations on a disk group:

- All devices in the primary disk group and secondary disk group must be attached.
- None of the pairs can be in the Synchronized or Restored state.

For detach operations on device pairs:

- The device pair must be previously attached.
- The device pair must not be in the Synchronized or Restored state.
- The device pair must be in the Split or Never Established state before detaching.

To detach STD devices from the BCV devices, use any of the following commands:

```
vxsymsetup -g PriDg [-o enclosure_sno=Symmetrix-id \  
-s PriDev:SecDev[,PriDev:SecDev,...] [-n]   
detach  
vxsymsetup -g PriDg [-o enclosure_sno=Symmetrix-id \  
-o filename=file [-n] detach
```

To detach a STD disk group from a BCV disk group use the following command:

```
vxsymsetup -g PriDg:SecDg [-n] detach
```

where:

*PriDg* is the VxVM disk group to which the STD device currently belongs.

*SecDg* is the VxVM disk group to which the BCV device currently belongs.

*Symmetrix-id* is the Symmetrix serial ID of STD/BCV devices.

*PriDev* and *SecDev* are STD and BCV device names. If `-o enclosure_sno` is specified, use Symmetrix device names. Without the `-o enclosure_sno` option, use the VxVM disk access name.

*file* is the file containing device pairs.

### Examples

```
vxsymsetup -g emcdg -s c0t0d0s2:c0t6d0s2 detach
vxsymsetup -g emcdg -o enclosure_sno=000111222333 \
-s 012:0A8 detach
vxsymsetup -g emcdg:bcvdg detach
vxsymsetup -g emcdg -o filename=file detach
```

The entries in the file will be:

```
#STD          #BCV
c0t0d0s2     c0t6d0s2
```

or this when enclosure\_sno is specified:

```
#STD          #BCV
012          0A8
```

The `vxsymsetup detachall` command detaches all the BCV devices from an STD device that were earlier attached or mirrored and split (and with which incremental mirror or incremental restore was possible). If only the primary disk group is specified, this operation is performed on all the STD devices in this VxVM disk group. If STD devices are specified, the command detaches all the BCV devices attached to or mirrored with these STD devices.

To detach all devices use the following commands:

```
vxsymsetup -g PriDg detachall
vxsymsetup -g PriDg [-o enclosure_sno=Symmetrix-id] \
-s PriDev[,PriDev,...] [-n]
detachall
```

### Examples

```
vxsymsetup -g emcdg detachall
vxsymsetup -g emcdg -s 01A,01B detachall
```

## Recovering crashed commands

The `vxsymrecover` command can recover any of the following VxFAS commands if they crash:

- `vxsymsetup attach`
- `vxsymsetup reattach`
- `vxsymsetup detach`
- `vxsymsetup detachall`
- `vxsymsplit`
- `vxsymmir`
- `vxsymremir`
- `vxsymrestore`

When any of the above commands is executed, it creates the log file `/etc/vx/emc.d/vxtflog.txt`. The file exists only as long as the command is running. The log file remains when a command crashes. Run `vxsymrecover` to recover this crashed command.

Similarly, if any VxFAS commands are killed, it leaves a log in the log file. If any other VxFAS command is executed before recovering the crashed command, the command exits with an error message. In this case, run `vxsymrecover` to recover the crashed command first, then run any other VxFAS command.

### Example

```
vxsymrecover
```

## Viewing device information

To view information about devices or confirm the initialization or state of the devices, use the `vxprint` and `vxsymquery` commands.

### The `vxprint` command

To display information about Volume Manager objects, use the `vxprint` command:

```
vxprint [-g diskgroup]
```

#### Example

If `c0t2d0s2` is added to VxVM disk group `emcdg` as `disk02` and a volume named `foo` is created, `vxprint` displays the following information:

```
# vxprint -g emcdg
Disk group: emcdg
```

TY	NAME	ASSOC	KSTATE	LENGTH	PLOFFS	STATE	TU
TILO	PUTIL0						
dg	emcdg	emcdg	-	-	-	-	-
	-						
dm	disk02	c0t2d0s2	-	4152640	-	-	-
	-						
v	foo	fsgen	ENABLED	1331520	-	ACTIVE	-
	-						
pl	foo-01	foo	ENABLED	1331520	-	ACTIVE	-
	-						
sd	disk02-01	foo-01	ENABLED	1331520	0	-	-
	-						

### The `vxsymquery` command

The `vxsymquery` command displays the status of Symmetrix devices operated on by VxFAS. The `vxsymquery` command displays information about the state of devices in the specified VxVM disk group. If the disk group name is not specified, `vxsymquery` displays information about all VxVM disk groups under operation by VxFAS.

To display information about STD and BCV Symmetrix devices, use the `vxsymquery` command.

```
vxsymquery [-g PriDg] [-o multibcvs]
vxsymquery -g PriDg -o verify[=synched|restored]
```

where:

*PriDg* is the VxVM disk group to which the STD devices currently belong.



If `synched` or `restored` is used with the `-o verify` option, `vxsymquery` checks if all the devices are in a synchronized or restored state, respectively.

The `-o multibcvs` option shows information for multiple BCVs. It shows device status for all the BCV devices attached to or mirrored with the STD devices. In the output, BCV devices currently attached to the STD devices are indicated by an asterisk (\*) following the BCV device name.

After attaching STD device `c0t1d0s2` to BCV device `c2t2d4s2` using `vxsymsetup attach`, the `vxsymquery` output looks like this:

```
# vxsymquery -g emcdg
Symmetrix id      : 000183600433
Device group     : vxvm_emcdg
Primary          Inv Tracks    Secondary          Inv Tracks    State
-----
c0t1d0s2          0          c2t2d4s2          45          Split
```

An STD-BCV pair can be in one of the following states:

NeverEstab	Never established state
SyncInProgress	Synchronization in progress
Synchronized	Synchronization done
SplitInProgress	Split in progress
Split	Split done
SplitNoInc	Device cannot be incrementally established or restored
SplitBfrSync	Split before synchronization
Restored	Restore done
RestInProgress	Restore in progress
SplitBfrRest	Split before restore

The `-o verify` option of `vxsymquery` indicates whether some or all device pairs in the specified disk group are in the Synchronized or Restored state. The `verify=synched` option checks whether the devices are in the Synchronized state. The `verify=restored` option checks whether the devices are in the Restored state. Because this option verifies the states of devices in a particular disk group, the disk group must be specified.

### Example

```
vxsymquery -g emcdg -o verify=synched
```

---

#### Notes:

---

- No VxFAS operation, except the Query operation, can be executed when another VxFAS operation or recovery of a crashed VxFAS operation is already in progress on the same host.
  - A recovery operation for VxFAS (`vxsymrecover` command or from the GUI) cannot be executed when any VxFAS operation (except Query operation) or a recovery operation is already in progress on the same host.
-

## Disk group reconfiguration

Starting with the Veritas Volume Manager 4.0 release, you can split an imported disk into two disk groups (`vx dg split`), join two imported disk groups into one disk group (`vx dg join`), or move specified objects together with their hierarchies from one imported disk group to another imported disk group (`vx dg move`).

After doing disk group split, join, or move operations on VxVM disk groups, if the disk group has valid VxFAS attachments, VxFAS reconfigured the corresponding device groups.

Disk group split, join, or move operations fail if any of the following validations fail:

- For the destination disk group `destdg`, if the corresponding device group `vxvm_destdg` already exists, the type (`Regular`, `RDF1`, or `RDF2`) of the device group must be compatible with the STD devices being added to the device group.
- For the destination disk group `destdg`, the STD devices being added to the device group `vxvm_destdg` (and those present in the device group if the device group already exists) must belong to the same Symmetrix array
- For the destination disk group `destdg`, none of the STD devices being added to the device group `vxvm_destdg` (and those present in the device group if the device group already exists) can be in any of the following states:
  - `Synchronized`
  - `Restored`
  - `Sync-in-progress`
  - `Restore-in-progress`
- If any of the STD devices in the disk group `destdg` involved in the move operation is in `Split-before-sync` (or `Split-before-restored` state), none of the devices in the device group `vxvm_destdg` can be in `Split-before-restored` (or `Split-before-sync` state).

If all the above validations pass, the following reconfiguration takes place for the specified disk group `destdg`:

- The device group `vxvm_destdg` is created if it does not already exist
- The STD devices moved to the disk group `destdg` are added to the device group `vxvm_destdg`
- All the BCV devices attached to the STD devices are disassociated from their existing device group and are associated to the device group `vxvm_destdg`
- If the device group corresponding to the source disk group for the operation becomes empty, it is destroyed.

While the operation is in progress, the file `/etc/vx/emc.d/vxvmlog.txt` is used to log the operation. If the operation crashes, you can recover using the `vxsymrecover -o cmd=vxdg` command after running the `vxdg recover` command. The following operations on the disk groups in the crashed operation cannot be performed until the recovery completes:

- Disk group import
- Disk group deport or destroy
- Addition of disks to the disk group
- Removal of disks from the disk group
- Associating a DA record to different DM record in the disk group
- Disk group split, join or move

---

**Note:** The device group reconfigurations mentioned above are performed for split, join, and move operations on the STD disk groups only. If split, join, or move operations are performed on an STD disk group, similar operations must be performed on disk groups containing attached BCV disks. To make new device group configuration reflect in agent database, a `rescan` operation is required on the Symmetrix array containing that device group.

In a high availability environment, reconfiguration of a device group for which the `VxSymDevGrp` resource is configured requires changes to that cluster configuration. See the Veritas Cluster Server Agents for Veritas FlashSnap Agent for Symmetrix Installation and Configuration Guide for more information on changes to cluster environment that must be done after reconfiguring the VxVM disk group using any of the above operations.

---

### Disk Group Rename Operation

If a VxVM disk group having valid VxFAS attachments is renamed (using the `-n` option for the `vxdg import` and `vxdg deport` commands), VxFAS also renames

the corresponding device group. For example, if the VxVM disk group *mydg* has valid VxFAS attachments and is renamed as *newdg*, the device group `vxvm_mydg` is renamed `vxvm_newdg`.

---

**Note:** After renaming the disk group, its corresponding device group is renamed. To make the new name of the device group appear in the agent database, a `rescan` operation must be performed on the Symmetrix array containing that device group.

In a high availability environment, after renaming a VxVM disk group, you must manually change the `DgName` attribute of the `VxSymDevGrp` type of resource corresponding to that VxVM disk group. See the Veritas Cluster Server Agents for Veritas FlashSnap Agent for Symmetrix Installation and Configuration Guide for more information on how to change the resource attribute.

---

## Policy setting support for EMC rules for Volume Manager

EMC rules for Volume Manager are divided into *optional* and *mandatory* categories. Adding CKD, VCMDB (Volume Logix Database), DRV (Dynamic Reallocation), or GK (Gatekeeper) types of Symmetrix devices to a Volume Manager disk group is a mandatory configuration rule and is always checked. All the other configuration rules are optional and can be disabled.

The `vxsymrule` command can set the policy to check all rules or only the mandatory rules. The `vxsymrule` command also displays the current policy. The default policy is to check all the configuration rules. The rule checking policy can be set during the VxFAS installation and can be changed at any time.

To enable rules checking, type:

```
# vxsymrule enable
```

To disable rules checking, type:

```
# vxsymrule disable
```

To check current policy of rules checking, type:

```
# vxsymrule mode
```

# Using the Veritas FlashSnap Agent for Symmetrix with VEA

This chapter describes how to use the FlashSnap Agent for Symmetrix (VxFAS) using the Veritas Enterprise Administrator (VEA) GUI interface. The following topics are covered in this chapter:

- [The VEA console](#)
- [Configuring options for EMC Symmetrix arrays in the StorageAgent](#)
- [Attaching devices](#)
- [Mirroring devices](#)
- [Splitting devices](#)
- [Restoring devices](#)
- [Detaching devices](#)
- [Querying snapshot information](#)
- [Recovering a crashed VxFAS operation](#)
- [Recovering a crashed disk group reconfigure operation](#)
- [Viewing object properties](#)
- [Notes on VxFAS menu options](#)

## The VEA console

The VERITAS Enterprise Administrator console is the centralized interface through which you can perform various management operations on hosts or agents that join the Central Server. You can connect to multiple Central Servers from one console. To run VEA, you must have the VEA GUI client package, `VRTSobgui`, installed on your system.

See the *Veritas Enterprise Administrator User's Guide* and the *Veritas Storage Foundation Installation Guide* for more information about the VEA console.



# Configuring options for EMC Symmetrix arrays in the StorageAgent

The StorageAgent collects information about EMC Symmetrix arrays periodically and makes the Symmetrix devices and device group configuration information available for management.

## Configure the options for the array:

- 1 Select **Control Panel** from the left pane. Expand the node under Central Server. Expand the node under the host where you are configuring the Symmetrix arrays. Select the StorageAgent node in the tree view.
- 2 Double click the **EMC Symmetrix Arrays** icon in the details view to display the following dialog box.

## Set Symmetrix Polling Interval

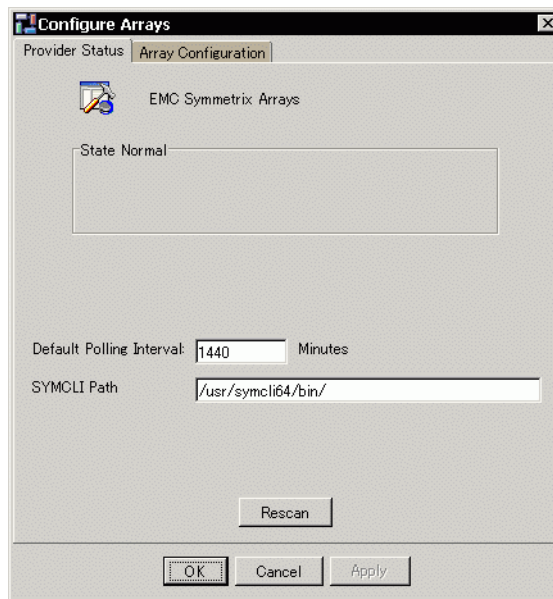

The default polling interval is the interval at which the StorageAgent automatically refreshes the configuration information for the EMC Symmetrix arrays connected to that host. You can change the interval by specifying a new value in the **Default Polling Interval** field. To refresh the configuration information manually, click the **Rescan** button.

---

**Caution:** Rescanning the configuration information for the Symmetrix arrays may take a significant amount of time to complete.

All VxFAS operations fail if a rescan is in progress. To determine if a rescan operation is in progress, look for the **Discovering EMC Symmetrix Arrays** task in the VEA console task pane.

---

## Attaching devices

Before you can set up *TimeFinder* mirroring, you must associate a Symmetrix standard (STD) device with a Business Continuance Volume (BCV) device. This procedure attaches an STD device to a BCV device to create an STD-BCV pair (or *attachment*).

### To perform the attach operation:

- 1 Right click the **STD disk group** node in the tree view to display the context menu. The context menu has options corresponding to the operations that can be performed on this disk group. The same menu can be accessed from the main menu bar under the **Actions** menu.

## STD Disk Group Context Menu

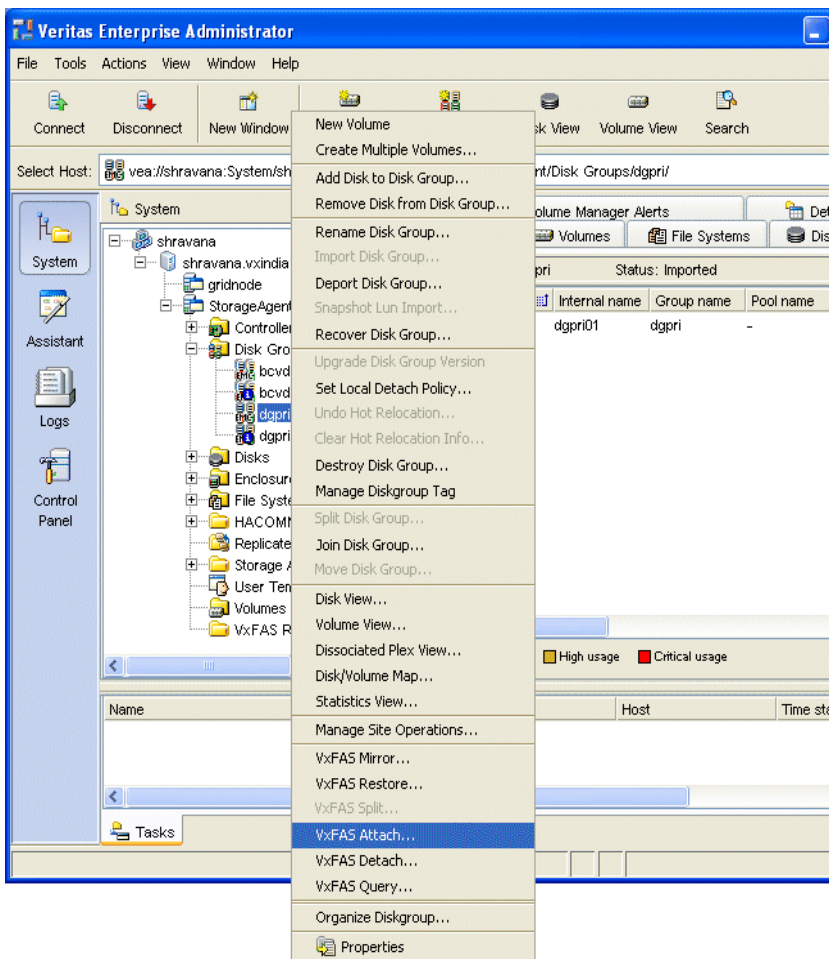

- 2 Click the **VxFAS Attach...** menu option. The following dialog is displayed:

## VxFAS Attach Dialog

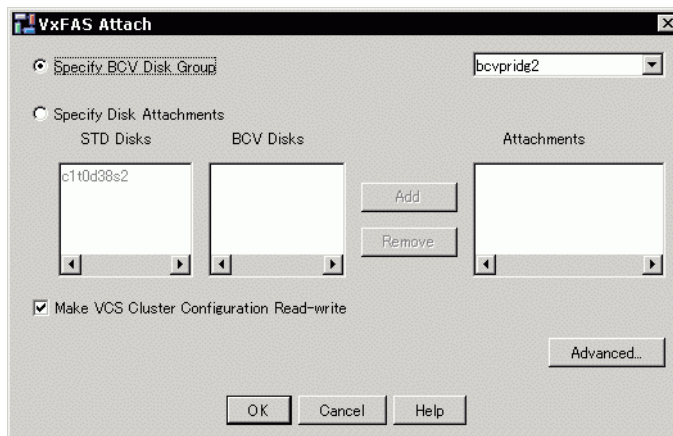

- 3 You can specify a disk group containing BCV disks or individual STD-BCV disk pairs for the attach operation.  
To specify a BCV disk group, select the **Specify BCV Disk Group** radio button, then select the name of the BCV disk group from the drop down list box.  
To specify individual STD-BCV disk pairs:
  - a Select the **Specify Disk Attachments** radio button.
  - b Select the STD device from **STD Disks** list. A list of compatible BCV disks appears in the **BCV Disks** list.
  - c Select a BCV device from **BCV Disks** list.
  - d Click the **Add** button to add the selected STD-BCV pair to the **Attachments** list.
  - e Repeat [step b](#) through [step d](#) to specify more pairs.
  - f To remove a pair, select that pair in the **Attachments** list and click the **Remove**.

---

**Note:** The **BCV Disks** list shows only those BCV disks that are compatible with the selected STD disk and are not already selected for attachment with some other STD disk in the same VxVM disk group.

---

- 4 Check **Make VCS Cluster Configuration Read-write** if the operation is going to be executed in HA mode and you want the VCS cluster configuration to be read-write (if necessary) automatically.
- 5 Click the **Advanced...** button to bring up a dialog with additional options:

VxFAS Attach Advance Dialog



Check **Reattach devices** if you want to reattach the BCV disks in the specified BCV disk group during the attach operation.

Check **Allow to move devices from their device groups** if you want VxFAS to move devices from their existing device group to the correct device group.

Click **Cancel** to discard the options, or click **OK** to accept the options and return to the **VxFAS Attach** dialog.

---

**Note:** These options are mutually exclusive.

**Reattach devices** option is meaningful only if you have specified the BCV disk group for attach operation.

---

- 6 After you have provided all necessary information in the **VxFAS Attach** dialog, click **OK**.

## Mirroring devices

This procedure mirrors Symmetrix STD devices in a disk group. This operation initiates *TimeFinder* mirroring for the Symmetrix STD devices that correspond to the specified disk group. The STD devices are mirrored to attached Symmetrix BCV devices.

### To mirror STD devices:

- 1 Display the STD disk group context menu by following the procedure described in [step 1](#) on page 67 in “[Attaching devices.](#)”
- 2 Select the **VxFAS Mirror...** menu option. The following dialog is displayed:

#### VxFAS Mirror Dialog

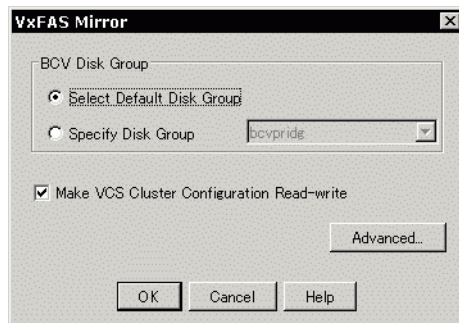

- 3 Choose **Select Default Disk Group** if you want VxFAS to use the default BCV disk group name for mirror operation. Choose **Specify Disk Group** if you want to specify an existing BCV disk group to mirror from the drop down list box.
- 4 Check **Make VCS Cluster Configuration Read-write** to execute the option in HA mode and if you want the VCS cluster configuration to be read-write (if necessary) automatically.

**Mirroring devices**

- 5 Click the **Advanced...** button to bring up a dialog with additional options:

VxFAS Mirror Advance Dialog



**Mirror Type** specifies the type of mirror operation to carry out.

Select **Full Mirror** if this is the first time you are mirroring the disk group.

If you select **Incremental Mirror**, only changed disk tracks are copied to the BCV device.

Check **Wait for Synchronization** if you want the VxFAS operation to wait until the mirror synchronization completes.

Click **Cancel** to discard the options. Click **OK** to accept the options and return to the **VxFAS Mirror** dialog box.

- 6 After you have provided all necessary information in the **VxFAS Mirror** dialog, click **OK**.



# Splitting devices

After mirroring the STD devices to BCV devices, you can split the BCV devices from the STD devices and use the BCV devices for administrative tasks, such as backups and testing, while the STD devices remain online.

This procedure splits Symmetrix STD-BCV pairs and creates a new disk group on the BCV devices. This disk group is a clone of the STD disk group.

## To split STD-BCV pairs:

- 1 Display the STD disk group context menu by following the procedure described in [step 1](#) on page 67 in “[Attaching devices.](#)”
- 2 Select the **VxFAS Split...** menu option. The following dialog is displayed:

### VxFAS Split Dialog

VxFAS Split

BCV Disk Group Name:

Mount Options

Do Not Mount BCV File Systems

Read-only Mount

Read-write Mount

VxFS Freeze Timeout (Seconds):

BCV Mount Root:

Make VCS Cluster Configuration Read-write

Advanced...

OK Cancel Help

**Splitting devices**

- 3 In the **BCV Disk Group Name** text box you can specify the name of the BCV disk group that is created when the split is complete, or you can accept the default name shown.
- 4 The mount options indicate the options for the BCV file system.

Options	<ul style="list-style-type: none"> <li>■ Select <b>Do Not Mount BCV File Systems</b> if you do not want the file systems on BCV volumes to be mounted after the split operation.</li> <li>■ Select <b>Read-Only Mount</b> if you want the BCV file systems to be mounted with read-only permissions after the split operation.</li> <li>■ Select <b>Read-write Mount</b> if you want the BCV file systems to be mounted with read-write permissions after the split operation.</li> <li>■ Specify the timeout value in seconds in the <b>VxFS Freeze Timeout</b> text box for freezing the VxFS file system on STD volumes.</li> <li>■ Specify the location where you want to mount the BCV file systems in the <b>BCV Mount Root</b> text box.</li> </ul>
---------	--

- 5 Check **Make VCS Cluster Configuration Read-write** if the operation is going to be executed in HA mode and you want the VCS cluster configuration to be read-write (if necessary) automatically.

- 6 Click the **Advanced...** button to bring up a dialog with additional options:

VxFAS Split Advanced Dialog



The **Instant Split** option is selected by default. Unselect this option if you do not want to perform the Instant Split operation.

Check **Wait for Split** if you want the VxFAS operation to wait until the split completes.

Click **Cancel** to discard the options, or click **OK** to accept the options and return to the **VxFAS Split** dialog box.

- 7 After you have provided all necessary information in the **VxFAS Split** dialog, click **OK**.

## Restoring devices

To replace the contents of the STD devices with the contents of the BCV devices, restore the STD devices from the BCV devices. This may be necessary if the STD devices are damaged. The data is copied from the BCV device to the STD device.

To restore STD devices:

- 1 Display the STD disk group context menu by following the procedure described in [step 1](#) on page 67 in “[Attaching devices](#).”
- 2 Select the **VxFAS Restore...** menu option. The following dialog is displayed:

VxFAS Restore Dialog



- 3 Select **Select Default Disk Group** if you want VxFAS to use the default BCV disk group name for restore operation. Select **Specify Disk Group** to specify an existing BCV disk group to restore from the drop down list box.
- 4 Check **Make VCS Cluster Configuration Read-write** if the operation is going to be executed in HA mode and you want the VCS cluster configuration to be read-write (if necessary) automatically.

- 5 Click the **Advanced...** button to bring up a dialog with additional options:

#### VxFAS Restore Advanced Dialog



**Restore Type** specifies the type of restore operation to perform.

Select **Full Restore** if this is the first time you are restoring the disk group. If you select **Incremental Restore**, only changed disk tracks are copied to the STD device.

Check **Wait for Restore** if you want the VxFAS operation to wait until the restore is completed.

Click **Cancel** to discard the options, or click **OK** to accept the options and return to the **VxFAS Restore** dialog box.

- 6 After you have provided all necessary information in the **VxFAS Restore** dialog, click **OK**.

## Detaching devices

This procedure detaches Symmetrix STD devices from attached BCV devices. An STD-BCV pair must be detached before a disk is moved from one VxVM disk group to another.

To perform the detach operation:

- 1 Display the STD disk group context menu by following the procedure described in [step 1](#) on page 67 in “Attaching devices.”
- 2 Select the **VxFAS Detach...** menu option. The following dialog is displayed:

VxFAS Detach Dialog

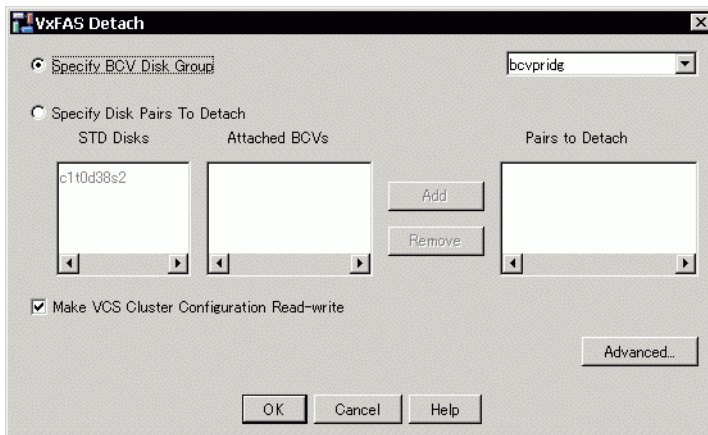

- 3 You can either specify a disk group containing BCV disks or individual STD-BCV disk pairs for the detach operation. To specify a BCV disk group, select **Specify BCV Disk Group** and select the name of the BCV disk group from the drop down list box. To specify individual STD-BCV disk pairs:
  - a Select **Specify Disk Pairs to Detach**.
  - b Select the STD device from the **STD Disks** list. A list of attached BCV disks appears in the **Attached BCVs** list.
  - c Select a BCV device from the **Attached BCVs** list.
  - d Click **Add** to add the selected STD-BCV pair to the **Pairs to Detach** list.
  - e Repeat [step b](#) through [step d](#) to specify more pairs.
  - f To remove a pair, select that pair in the **Pairs to Detach** list and click **Remove**.

- 4 Check **Make VCS Cluster Configuration Read-write** if the operation is going to be executed in HA mode and you want the VCS cluster configuration to be read-write (if necessary) automatically.
- 5 Click the **Advanced...** button to bring up a dialog with additional options:

VxFAS Detach Advanced Dialog

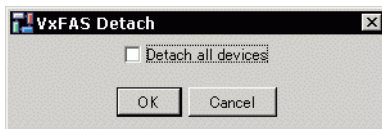

Check **Detach all devices** if you want to detach all the BCV disks that are attached to the STD device.

Click **Cancel** to discard the option, or click **OK** to accept the option and return to the **VxFAS Detach** dialog.

- 6 After you have provided all necessary information in the **VxFAS Detach** dialog, click **OK**.

---

**Note:** The **Attached BCVs** list shows only those BCV disks that are attached with the selected STD disk.

---

## Querying snapshot information

You can query the snapshot information for a disk group or all disk groups on the server. You can query the status of the STD-BCV pairs in a disk group using this menu.

### To query snapshot information

- 1 Display the STD disk group context menu by following the procedure described in [step 1](#) on page 67 in “[Attaching devices.](#)”
- 2 Select the **VxFAS Query...** menu option. The following dialog is displayed:

VxFAS Query Dialog

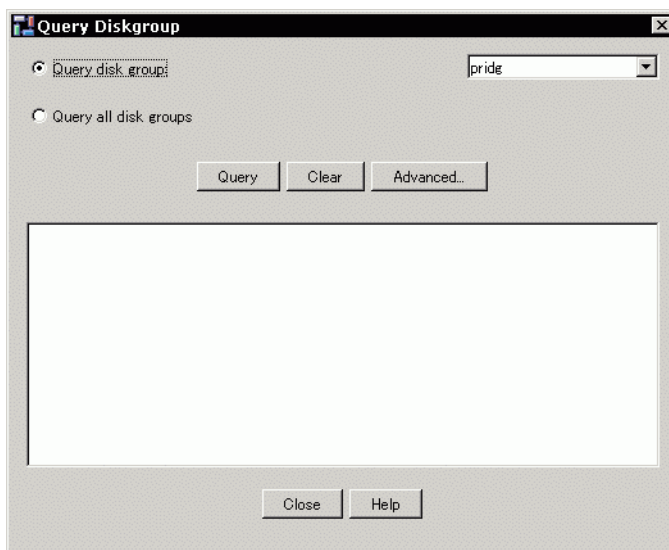

- 3 You can specify a disk group or query setup information for all disk groups on the server.  
To query snapshot information for a disk group, select the **Query Disk group** radio button and select the name of disk group from the drop down list box.  
To query snapshot information for all disk groups on the server, select **Query all disk groups**.



- 4 Click the **Advanced...** button to bring up a dialog with additional options:

#### VxFAS Query Advanced Dialog

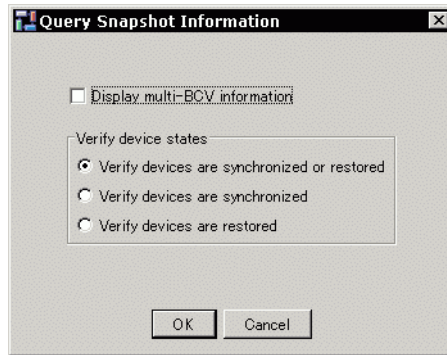

Select **Display multi-BCV information** to query the multiple BCV information for the disk group.

Select an option from **Verify device states** to determine if the devices can reach the preferred state.

Click **Cancel** to discard the option, or click **OK** to accept the option and return to the **VxFAS Query** dialog.

- 5 Click **Query** to start the query operation. The output of the query operation is shown in the text box on the **VxFAS Query** dialog.
- 6 You can clear the contents of the text box by clicking **Clear**.
- 7 Click **Close** to close the **VxFAS Query** dialog.

## Recovering a crashed VxFAS operation

To recover a crashed VxFAS operation from the VEA console:

- 1 Right click on the **VxFAS Recovery Service** node in the tree view to display the context menu. The context menu has options corresponding to the operations that the VxFAS Recovery Service can perform. The same menu can be accessed from the main menu bar under the **Actions** menu.

VxFAS Recovery Service Context Menu

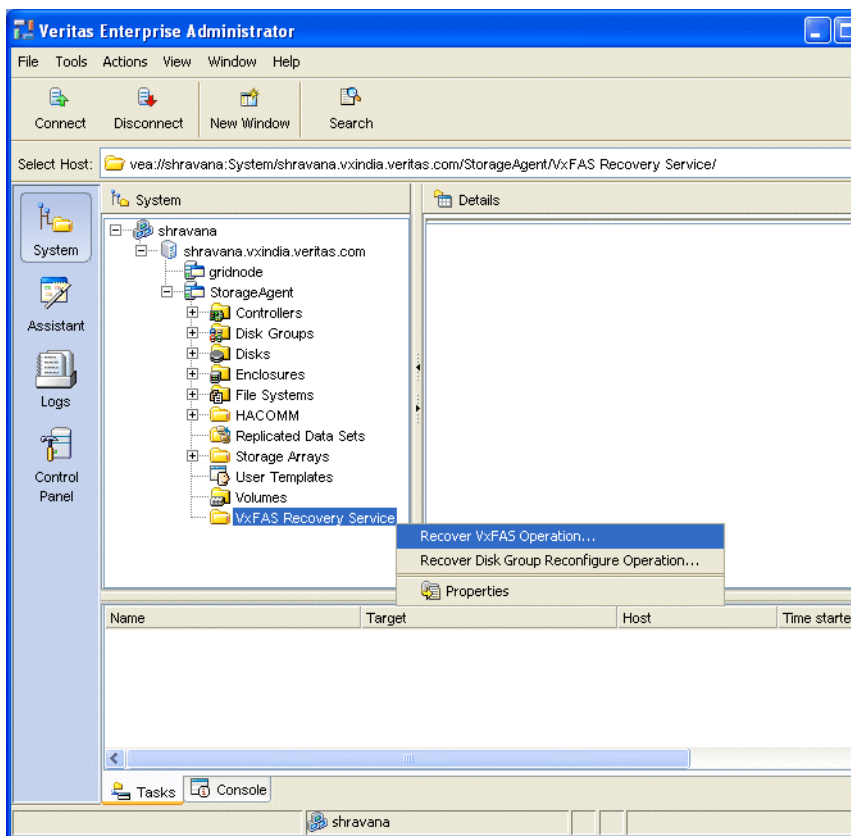

- 2 Select the **Recover VxFAS Operation...** menu option. A message box prompting whether to perform recovery of a VxFAS operation is displayed.
- 3 Click **OK** to start recovery of a crashed VxFAS command.

## Recovering a crashed disk group reconfigure operation

To recover a crashed disk group reconfigure operation from the VEA console:

- 1 Display the VxFAS Recovery Service context menu by following the procedure described in [step 1](#) on page 82 in “[Recovering a crashed VxFAS operation.](#)”
- 2 Select the **Recover Disk Group Reconfigure Operation...** menu option. A message box prompting whether you want recovery of a disk group reconfigure operation is displayed
- 3 Click **OK** to start recovery of a crashed disk group reconfigure operation.

## Viewing object properties

- To view the snapshot-related properties of all disks, select the **Assigned Storage** node under the **EMC Symmetrix Array** object node in the tree view of the left pane. The snapshot view displays the snapshot properties for all disks mapped to that host. Each row of the snapshot view corresponds to one disk, and the columns correspond to the properties of the disk.
- To view the properties of a disk, click the disk node in the tree view of the left pane and select **Properties** from the context menu.
- The **Properties** window contains a set of tabbed pages, each of which contains categorized information about the selected object. You can display a different page by clicking the appropriate tab label.

## Notes on VxFAS menu options

- All the menu options for VxFAS operations are disabled during the interval when the first rescan operation is in progress on the selected Symmetrix array after starting the StorageAgent.
- Menu options for all VxFAS operations except **Query** are enabled only on disk groups containing STD disks.
- Menu options for VxFAS operations (except the **VxFAS Query** operation) on a disk group are disabled if a VxFAS operation is already in progress on that disk group.
- Menu options for only those VxFAS operations that are valid for a specified disk group are enabled on the menu. For example, after you perform the **VxFAS Mirror** operation, only the **VxFAS Split** operation is enabled on the menu. The **VxFAS Query** operation, however, is always enabled on the menu.
- VxFAS operations are not supported on Cluster Volume Manager (CVM) shared disk groups, VxVM SAN disk groups, or disk groups containing VVR replicated volume groups, so for these disk group types, VxFAS menu options are not enabled.

# Troubleshooting

This chapter discusses problems encountered while using Veritas FlashSnap Agent for Symmetrix and their possible remedies. The following topics are covered in this chapter:

- [VxFAS pre-operation conditions](#)
- [Common error messages](#)
- [The vxtexplorer.sh diagnostic script](#)

## VxFAS pre-operation conditions

If a VxFAS command warns about a configuration issue, check if your configuration meets the following conditions.

### Conditions common to all VxFAS operations:

- The STD and BCV disk groups must have same disk group type (Regular/RDF1/RDF2).
- The STD disk group must be imported.
- The devices in STD and BCV disk groups must belong to the same *Symmetrix*. VxFAS does not support operations on disk groups containing devices from multiple *Symmetrix* arrays.
- If the operation is on disk pairs, and the list of disks is provided, all BCV devices must belong to same disk group or to none.
- All the devices mentioned in command should be visible to VM and should be in `ONLINE` state.
- The number of STD and BCV devices specified in the operation on disk-pairs must be equal. If the operation is on disk groups, the number of STD and BCV devices in the corresponding device groups must be equal.
- If the STD disk group contains a Meta device, the BCV disk group must also contain a meta device of the same configuration.
- The name of STD and BCV disk groups must be different.

### Conditions for Attach operation:

- The STD and BCV disk groups must be imported.
- The sizes of the STD and BCV devices involved in the operation must be equal.
- The total mirror count of STD plus BCV pair cannot exceed 4.  
 For Example: you can attach a 2-Way Mir STD device to a 2-Way BCV Mir device but not to 3-Way BCV Mir device because the total number of mirrors exceeds four.
- The Meta status of STD and BCV devices involved in attach operation must match. When you are attaching disk group having a Meta-STD and simple STD device then the BCV disk group must also contain one Meta-BCV and simple BCV device of matching configuration.
- You cannot attach the same STD device to two or more BCV devices at a time in an operation.
- You cannot attach the same BCV device to two or more STD devices at a time in an operation.

### Conditions for Mirror operation:

- BCV disk group in the operation cannot be `bootdg`.
- Mirror operation is not allowed on BCV disk groups having `rootvol/swapvol`.

### Conditions for Restore operation:

- Restore operation is not allowed on STD or BCV disk group having `rootvol/swapvol`.
- STD disk group cannot have mounted file systems.

### Conditions for Split operation:

- The specified mount point seed must be a valid mount point.
- Mount point seed must not have a hidden mount point.
- If the file systems on STD volumes are not VxFS file systems, the split cannot be performed online. You must unmount those file systems then do the split.

## Common error messages

The following table lists common error messages that can be logged to the StorageAgent log file `/var/vx/isis/StorageAgent/StorageAgent.log` and the messages that are reported by the VxFAS command line utilities.

**Table 5-1** Common Errors And Corrective Actions

Error Number	Message	Action
V-31-1051-3	Doing re-mirror to rollback the split operation	Increase the VxFS timeout specified for the split command.
V-31-1051-191	No virtual disk object found in StorageAgent for disk <i>daname</i>	The agent database does not contain information for the given device. <ol style="list-style-type: none"> <li>1 Check if the array rescan operation is in progress.</li> <li>2 Run the command <code>vxddctl enable</code> and perform the array rescan.</li> </ol>
V-31-1051-51 V-31-1051-106	Unprocessed log exists	There exists some unprocessed log. Try running the command <code>vxsymrecover</code> to recover the crashed operation.
V-31-1051-92	Primary disk groups have mounted volumes	Unmount the primary file systems and retry the operation.
V-31-1051-100	Cannot lock log device <i>logdev</i> . Lock held by process <i>pid</i>	Check if some other VxFAS operation is already in progress. Two VxFAS operations cannot run simultaneously on the same host.
V-31-1051-105	Cannot reserve a disk for logging	Check if log disks are configured and are available for VxFAS to use.
V-31-1051-108	Insufficient log information logged	There is not enough information in the log file to recover a crashed command. You may rerun the crashed command.
V-31-1051-134	Device access name <i>daname</i> is invalid	Check if the VxVM disk you are trying to use is initialized properly and is visible to VxVM.
V-31-1051-142	Secondary devices belong to different disgorges	Check if all the BCV devices belong to the same VxVM disk group.



**Table 5-1** Common Errors And Corrective Actions

Error Number	Message	Action
V-31-1051-160	The device with daname <i>daname</i> is used on some other host	Check if the device you are trying to use is part of some disk group imported on some other host. If found <ol style="list-style-type: none"> <li>1 Remove the device from that disk group.</li> <li>2 Perform <code>vxctl enable</code> on this host</li> <li>3 Perform array rescan operation.</li> </ol>
V-31-1051-164	Cannot operate on a mix of simple and sliced devices	Check if your disk group contains mix of VxVM disk of simple and sliced formats.
V-31-1051-2071	Access Denied To logged in user	Check whether:
V-31-1051-2072	Cannot connect to StorageAgent	1 TheStorageAgent is in <i>RUNNING</i> state.
V-31-1051-2073	Cannot register to StorageAgent	2 The array rescan operation is complete.
V-31-1051-2076	Daname <i>daname</i> is invalid or object not in StorageAgent	The agent database does not contain information for the given device. <ol style="list-style-type: none"> <li>1 Check if the array rescan operation is in progress.</li> <li>2 If array rescan is not running, then run the command <code>vxctl enable</code> and then perform the array rescan.</li> </ol>
V-31-1051-2077	SymDev <i>symdev</i> is invalid or object not in StorageAgent	The agent database does not contain information for the given device. <ol style="list-style-type: none"> <li>1 Check if the array rescan operation is in progress.</li> <li>2 If array rescan is not running, then run the command <code>vxctl enable</code> and then perform the array rescan.</li> </ol>
V-31-1051-2126	VxVM disk <i>daname</i> has no corresponding virtual disks in StorageAgent	The correlation between VxVM devices and Symmetrix devices may not be completed yet. Retry the command after few minutes.
V-31-1051-3001	Cannot open VCS API session	Check if VCS is running correctly on the node.

**Table 5-1** Common Errors And Corrective Actions

Error Number	Message	Action
V-31-1051-3014	Cannot add <i>restype</i> resource for non-primary disk group <i>dgname</i>	There exists a DiskGroup type of resource for BCV disk group which is not required. The resources for the BCV disk group are created and maintained by VxFAS automatically.
V-31-1051-3015	Command rejected by VCS	Check if the VCS is running correctly on the node. VCS rejects the commands when the system state is not <i>RUNNING</i> .
V-31-1051-3026	Cannot connect to StorageAgent, Error <i>&lt;errcode&gt;</i>	Check if theStorageAgent is in <i>RUNNING</i> state.
V-31-1052-10	BCV pair status of secondary devices is mixed. Cannot attach.	The pair state information is mixed for BCV devices.
V-31-1052-14	BCV pair status mixed.	<ol style="list-style-type: none"> <li>1 Get all the BCV devices in one state using SYMCLI.</li> <li>2 Perform array rescan operation</li> <li>3 Retry the <code>vxsymsetup attach</code> command.</li> </ol>
V-31-1052-81	The device group name is too long	The length of the resultant device group name must be less than 32. VxFAS commands prefix <i>vxvm_</i> to the disk group name to get the device group name. This implies that the VxVM disk group name must be less than 27 characters.
V-31-1052-88	Devices do not have proper pairings	Run <code>vxsymsetup attach</code> command to setup pairing between the devices.
V-31-1052-89	Number of devices in the device group is more than that in the disk group	Remove devices that are not part of the disk group from the device group using SYMCLI and then perform array rescan.
V-31-1052-91	Devices are already in target state	Informative message. The devices are already in the required state. For example, the operation is <i>mirror</i> or <i>restore</i> and the devices are already in <i>Synchronized</i> state.
V-31-1052-92	Devices are not established earlier, cannot reattach.	Run the <code>vxsymsetup attach</code> operation instead of <code>reattach</code> .

**Table 5-1** Common Errors And Corrective Actions

Error Number	Message	Action
V-31-1052-94	Some of the devices are not in proper state for the operation	The current state of the devices must be compatible for the operation. For example, for <code>split</code> operation the devices should be in synchronized or restored states, or for <code>attach/detach</code> operations the devices should be in split state.
V-31-1052-129	No attachment found for the devices in the two disk groups	Perform the <code>vxsymsetup attach</code> operation to setup the attachments.
V-31-1052-134	No matching BCV device found for STD device <code>stddev</code> , cannot do attach	Make sure that there is at least one matching BCV device for each STD device in the BCV disk group.
V-31-1052-148	Primary devices are not of same type	Check if the STD disk group contains a mix of STD and non-STD (BCV) devices.
V-31-1052-176	Symmetrix database is locked by some other process	Wait till the process that has locked the Symmetrix database to finish and then retry the operation.
V-31-1052-181	Secondary devices are not of same type	Check if the BCV disk group contains a mix of STD and non-STD (BCV) devices.
V-31-1052-187	Some of the devices are not paired	Setup attachments for all the devices in the STD disk group.
V-31-1052-291	Devices do not belong to a VxFAS device group	<ol style="list-style-type: none"> <li>1 Remove the devices from the current device group.</li> <li>2 Perform the array rescan operation.</li> <li>3 Retry the command.</li> </ol>
-	The restore operation fails with an error after deporting the STD and BCV disk groups but before starting copy of data from BCV devices to the STD devices.	The data from BCV devices is not yet copied on to the STD devices, so you can re-import the STD and BCV disk groups and try running the command again.

## The `vxtexplorer.sh` diagnostic script

This script collects log files and information about the environment in which VxFAS is running. It may help to diagnose a problem quickly.

- 1 The script is installed with the `VRTSfas` package in the `/etc/vx/emc.d/bin` directory. To use this script:
  - a Always run this program in a newly created sub-directory

```
# mkdir /tmp/problem123
# cd /tmp/problem123
```
  - b Enter the following command

```
# /etc/vx/emc.d/bin/vxtexplorer
```
- 2 You typically run this script three times to collect data for analysis:
  - Once on the primary node before any VxFAS command is run
  - Once on the secondary node just after the primary node crashes
  - Once on the secondary node after the failover completes, that is, after a service group is either ONLINE or OFFLINE
- 3 If no failover is involved, run the script twice on the same node, once before and once after the failing command.
- 4 Use the file upload facility of your Web browser, or the FTP program, to transfer the `vxtexplorer.sh` output files to the Symantec Customer Support anonymous FTP site:

```
ftp://ftp.veritas.com/incoming
```
- 5 Telephone Symantec Customer Support at the number listed at <http://support.veritas.com>. Tell them that you have run `vxtexplorer.sh` and provide the name of the file that you transferred to the FTP site.  
Alternatively, if you have already been assigned a case ID number by Customer Support, send email to `support@veritas.com` and include your case ID number in the subject line.

# Index

## A

- adding devices 34
- adding disks 36
- alert rules 12
- attaching device pairs 41, 67
- attaching devices 41, 67
- attachments 41, 67

## B

- BCV 9
- business continuance 9

## C

- commands
  - vxassist 15, 39
  - vxdg 36
  - vxprint 56
  - vxsymmir 43
  - vxsymremir 47
  - vxsymsetup 41
  - vxsymsplit 44
- confirming initialization 56

## D

- detaching device pairs 53, 78
- detaching devices 53, 78
- device names 11
- device pairs 44
  - attaching 41, 67
  - detaching 53, 78
  - splitting 73
- devices
  - adding 34
  - attaching 41, 67
  - detaching 53, 78
  - initial mirroring 43, 71
  - initializing 56
  - mirroring 43, 71
  - remirroring 47

- restoring 76
  - splitting 44, 73
- disk names 11
- disks
  - adding 36
- displaying object properties 84
- DMP (dynamic multi-pathing) 12

## H

- hyper volumes 12

## L

- LUN (logical unit number) 12

## M

- mirroring devices 43, 71

## O

- object properties
  - displaying 84

## P

- prevent rules 12
- properties 84
- properties window 84

## R

- RDF (remote data facility) 11
- remirroring devices 47
- remote data facility (RDF) 11
- restoring devices 76

## S

- splitting 44
- splitting device pairs 44, 73
- splitting devices 44, 73
- states of the STD-BCV pair 57

STD 9  
STD-BCV pairs 41, 67  
Symmetrix disk arrays 11

## **T**

task roadmap 16  
tasks 16

## **V**

viewing objects  
    properties 84  
Volume Manager 9  
vxassist 15, 39  
vxdg 36  
vxprint 56  
vxsymmir 43  
vxsymremir 47  
vxsymsetup 41  
vxsymsplit 44