

Solaris X Window System

Developer's Guide

SunSoft, Inc.
A Sun Microsystems, Inc. Business
2550 Garcia Avenue
Mountain View, CA 94043
U.S.A.



THE NETWORK IS THE COMPUTER™

Copyright 1997 Sun Microsystems, Inc. 2550 Garcia Avenue, Mountain View, California 94043-1100 U.S.A. All rights reserved.

This product or document is protected by copyright and distributed under licenses restricting its use, copying, distribution, and decompilation. No part of this product or document may be reproduced in any form by any means without prior written authorization of Sun and its licensors, if any. Third-party software, including font technology, is copyrighted and licensed from Sun suppliers.

Parts of the product may be derived from Berkeley BSD systems, licensed from the University of California. UNIX is a registered trademark in the U.S. and other countries, exclusively licensed through X/Open Company, Ltd.

Sun, Sun Microsystems, the Sun logo, SunSoft, SunDocs, SunExpress, Solaris, OpenStep, and OpenWindows are trademarks, registered trademarks, or service marks of Sun Microsystems, Inc. in the U.S. and other countries. All SPARC trademarks are used under license and are trademarks or registered trademarks of SPARC International, Inc. in the U.S. and other countries. Products bearing SPARC trademarks are based upon an architecture developed by Sun Microsystems, Inc. OPEN LOOK is a registered trademark of Novell, Inc. PostScript and Display PostScript are trademarks of Adobe Systems, Inc. X Window System is a trademark of X Consortium, Inc.

The OPEN LOOK and Sun™ Graphical User Interface was developed by Sun Microsystems, Inc. for its users and licensees. Sun acknowledges the pioneering efforts of Xerox in researching and developing the concept of visual or graphical user interfaces for the computer industry. Sun holds a non-exclusive license from Xerox to the Xerox Graphical User Interface, which license also covers Sun's licensees who implement OPEN LOOK GUIs and otherwise comply with Sun's written license agreements.

RESTRICTED RIGHTS: Use, duplication, or disclosure by the U.S. Government is subject to restrictions of FAR 52.227-14(g)(2)(6/87) and FAR 52.227-19(6/87), or DFAR 252.227-7015(b)(6/95) and DFAR 227.7202-3(a).

DOCUMENTATION IS PROVIDED "AS IS" AND ALL EXPRESS OR IMPLIED CONDITIONS, REPRESENTATIONS AND WARRANTIES, INCLUDING ANY IMPLIED WARRANTY OF MERCHANTABILITY, FITNESS FOR A PARTICULAR PURPOSE OR NON-INFRINGEMENT, ARE DISCLAIMED, EXCEPT TO THE EXTENT THAT SUCH DISCLAIMERS ARE HELD TO BE LEGALLY INVALID.



Please
Recycle



Adobe PostScript

Copyright 1997 Sun Microsystems, Inc., 2550 Garcia Avenue, Mountain View, Californie 94043-1100 Etats-Unis. Tous droits réservés.

Ce produit ou document est protégé par un copyright et distribué avec des licences qui en restreignent l'utilisation, la copie, la distribution, et la décompilation. Aucune partie de ce produit ou document ne peut être reproduite sous aucune forme, par quelque moyen que ce soit, sans l'autorisation préalable et écrite de Sun et de ses bailleurs de licence, s'il y en a. Le logiciel détenu par des tiers, et qui comprend la technologie relative aux polices de caractères, est protégé par un copyright et licencié par des fournisseurs de Sun.

Des parties de ce produit pourront être dérivées des systèmes Berkeley BSD licenciés par l'Université de Californie. UNIX est une marque déposée aux Etats-Unis et dans d'autres pays et licenciée exclusivement par X/Open Company, Ltd.

Sun, Sun Microsystems, le logo Sun, SunSoft, SunDocs, SunExpress, Solaris, OpenStep, et OpenWindows sont des marques de fabrique ou des marques déposées, ou marques de service, de Sun Microsystems, Inc. aux Etats-Unis et dans d'autres pays. Toutes les marques SPARC sont utilisées sous licence et sont des marques de fabrique ou des marques déposées de SPARC International, Inc. aux Etats-Unis et dans d'autres pays. Les produits portant les marques SPARC sont basés sur une architecture développée par Sun Microsystems, Inc. OPEN LOOK est une marque enregistrée de Novell, Inc. PostScript et Display PostScript sont des marques d'Adobe Systems, Inc. Le système X Window est un produit du X Consortium, Inc.

L'interface d'utilisation graphique OPEN LOOK et Sun™ a été développée par Sun Microsystems, Inc. pour ses utilisateurs et licenciés. Sun reconnaît les efforts de pionniers de Xerox pour la recherche et le développement du concept des interfaces d'utilisation visuelle ou graphique pour l'industrie de l'informatique. Sun détient une licence non exclusive de Xerox sur l'interface d'utilisation graphique Xerox, cette licence couvrant également les licenciés de Sun qui mettent en place l'interface d'utilisation graphique OPEN LOOK et qui en outre se conforment aux licences écrites de Sun.

CETTE PUBLICATION EST FOURNIE "EN L'ETAT" ET AUCUNE GARANTIE, EXPRESSE OU IMPLICITE, N'EST ACCORDEE, Y COMPRIS DES GARANTIES CONCERNANT LA VALEUR MARCHANDE, L'APTITUDE DE LA PUBLICATION A REpondre A UNE UTILISATION PARTICULIERE, OU LE FAIT QU'ELLE NE SOIT PAS CONTREFAISANTE DE PRODUIT DE TIERS. CE DENI DE GARANTIE NE S'APPLIQUERAIT PAS, DANS LA MESURE OU IL SERAIT TENU JURIDIQUEMENT NUL ET NON AVENU.

Contents

Preface.....	xv
1. Introduction to the Solaris X Server	1
About the Solaris X Server	1
X11R6 Sample Server.....	2
DPS Extension	4
X Consortium Extensions	4
AccessX.....	7
Shared Memory Transport	7
Visual Overlay Windows	7
X11 Libraries.....	8
Applications That Run With the Solaris X Server	8
Supported X11 Applications.....	9
Unsupported Applications.....	10
OpenWindows Directory Structure	10
Notes on X11 Programming	13

Compose Key Support	13
NumLock Key Support	13
Color Name Database	14
Color Recommendations.	14
Further Reading	15
2. DPS Features and Enhancements	17
About DPS	17
How DPS Works.	18
DPS Font Enhancements in the Solaris Server	20
DPS Libraries	20
Adobe NX Agent Support	20
DPS Security Issues	21
System File Access.	21
Secure Context Creation	21
When DPS Encounters Internal Errors	23
How To Access Information From Adobe.	23
DPS Compositing Operators	24
Operator Descriptions.	26
Implementation Notes and Limitations	31
3. Visuals on the Solaris X Server.	35
About Visuals	35
Default Visual.	36
Visuals on Multi-Depth Devices	37
Hints for Windows Programming With Visuals	37

Gamma-Corrected Visuals	38
Finding a Linear Visual	39
Visual Selection Alternatives	41
4. Font Support	43
Font Support in the Solaris X Server	43
X Font Server	44
Available Font Formats	44
Associated Files	45
Outline and Bitmap Fonts	46
Replacing Outline Fonts With Bitmap Fonts	47
Using TrueType and F3 Fonts in DPS	48
Locating Fonts	48
Changing the Default Font Path in X11	49
Installing and Managing Fonts	49
Using OPEN LOOK Fonts on X Terminals	50
5. Server Overlay Windows	51
Server Overlays Versus Transparent Overlays	51
Tips for Programming Overlays	52
Parent-Child Model	52
Stacking	52
Server Overlays	53
6. Transparent Overlay Windows	55
What are Transparent Overlay Windows?	55
Basic Characteristics of Transparent Overlay Windows	57

Paint Type	57
Viewability	58
Rendering Transparent Paint	58
More on Transparent Overlay Characteristics	58
Background.	59
Window Border	60
Backing Store	60
Window Gravity	60
Colormaps	61
Input Distribution Model	61
Print Capture	62
Choosing Visuals for Overlay/Underlay Windows	62
Example Program.	64
Overview of the Solaris Transparent Overlay Window API.	65
Creating Transparent Overlay Windows.	66
Setting the Paint Type of a Graphics Context.	67
Setting the Background State of a Transparent Overlay Window	68
Rendering to a Transparent Overlay Window	69
Querying the Characteristics of a Transparent Overlay Window	70
Determining Whether a Window is an Overlay Window.	70
Determining the Paint Type of a Graphics Context.	70
Pixel Transfer Routines	70
Filling an Area Using the Source Area Paint Type	71
Copying an Area and Its Paint Type	73

Retrieving Overlay Color Information	77
Using Existing Xlib Pixel Transfer Routines.	79
Designing an Application for Portability	80
Selecting a Visual for an Overlay/Underlay Window	81
Selecting an Optimal Overlay/Underlay Visual Pair	86
7. Security Issues.	91
Access Control Mechanisms.	92
User-Based	92
Host-Based	92
Authorization Protocols	93
MIT-MAGIC-COOKIE-1	93
SUN-DES-1	93
Changing the Default Authorization Protocol.	94
Manipulating Access to the Server	95
Client Authority File	96
Allowing Access When Using MIT-MAGIC-COOKIE-1. . . .	97
Allowing Access When Using SUN-DES-1.	97
Running Clients Remotely, or Locally as Another User	98
A. Reference Display Devices	99
Solaris Reference Display Devices	99
<i>SPARC</i> : Supported Reference Devices	100
<i>x86</i> : Supported Reference Devices	102
Glossary	105
Index	111

Figures

Figure 1-1	Solaris X Server	2
Figure 1-2	Solaris X Server Architecture	3
Figure 1-3	OpenWindows Directory Structure	11
Figure 2-1	DPS Extension to X	19
Figure 2-2	Compositing Operator Example Program	26
Figure 2-3	Results of Compositing Operations	29

Tables

Table 1-1	X11 Libraries.....	8
Table 1-2	OpenWindows Directories.....	11
Table 2-1	DPS Libraries.....	20
Table 2-2	Factors of the Compositing Equation.....	28
Table 4-1	Outline Font Formats.....	44
Table 4-2	Bitmap Font Formats.....	44
Table 4-3	Font File Availability.....	45
Table 4-4	Bitmap Font Binaries.....	47
Table 4-5	Font Directory Structure.....	48
Table 6-1	Background Values for a Transparent Overlay Window....	59
Table 6-2	List of Transparent Overlay Window Routines.....	65
Table 6-3	XSolarisOvlCopyPaintType Source/Destination Combinations and Actions.....	72
Table 6-4	XSolarisOvlCopyAreaAndPaintType Source/Destination Combinations and Actions.....	76
Table A-1	Solaris Reference Display Devices.....	100

Preface

The *Solaris X Window System Developer's Guide* provides detailed information on the Solaris™ X server. The guide provides an overview of the server architecture and tells you where to look for more information.

This guide provides detailed information for software developers interested in interfacing with the Solaris X server.

Who Should Use This Book

Programming in this environment primarily involves using a toolkit and possibly interfacing with the server and its protocols. The protocols and toolkits are documented elsewhere (see “Related Books” on page xvii). Read this manual if you need detailed information on the:

- Features of the Solaris X server
- Differences from and enhancements to the X Consortium sample server
- DPS imaging system
- Supported display devices
- Authorization schemes and protocols for server connections

Before You Read This Book

This manual assumes that the reader has a programming background and familiarity with, or access to, appropriate documentation for:

- Solaris 2.x
- X Window System™
- C programming language
- PostScript™
- The Display PostScript™ System (DPS)
- `olwm` window manager
- XView™ toolkit

How This Book Is Organized

Although you can read this book in sequence, it is designed for you to read only those chapters of interest. This book serves both as an overview and as a reference document.

Chapter 1, “Introduction to the Solaris X Server,” describes the architecture of the Solaris X server, the X and DPS extensions, Sun’s enhancements to the X Consortium libraries and extensions, notes on color-related issues, and a list of applications you can run with the server.

Chapter 2, “DPS Features and Enhancements” describes the DPS features specific to Solaris and includes information on compositing operators provided as an extension to standard DPS.

Chapter 3, “Visuals on the Solaris X Server,” describes visuals in the Solaris environment. It also provides hints for window programming with visuals.

Chapter 4, “Font Support,” describes the set of fonts provided and how to manage fonts.

Chapter 5, “Server Overlay Windows,” describes server overlays and contrasts them with transparent overlays.

Chapter 6, “Transparent Overlay Windows,” describes the Solaris Transparent Overlay Extension application programming interface (API) for transparent overlay windows.

Chapter 7, “Security Issues,” describes the security features of the Solaris environment.

Appendix A, “Reference Display Devices,” describes the graphics devices provided as reference devices with the Solaris environment.

Related Books

For information on how to write applications in the Solaris environment, consult the following manuals:

- *Desktop Integration Guide*
- *ToolTalk Reference Guide*
- *OpenWindows Desktop Reference Manual*
- *Solaris X Window System Reference Manual*
- *X Server Device Developer’s Guide*
- *Font Administrator User’s Guide*
- *XView Developer’s Notes*
- *OLIT QuickStart Programmer’s Guide*
- *OLIT Reference Manual*
- *XIL Programmer’s Guide*

The following X-related manuals are available through SunExpress or your local bookstore. Contact your SunSoft representative for information on ordering any of these books.

- *XView Reference Manual*, O’Reilly & Associates
- *XView Programming Manual*, O’Reilly & Associates
- *Xlib Reference Manual*, O’Reilly & Associates
- *Xlib Programming Manual*, O’Reilly & Associates
- *X Protocol Reference Manual*, O’Reilly & Associates
- *Programmer’s Supplement for Release 5*, O’Reilly & Associates
- *X Toolkit Intrinsic Reference Manual*, O’Reilly & Associates
- *X Window System, Third Edition*, Digital Press
- *The X Window System Server, X Version 11, Release 5*, Digital Press

The following PostScript and DPS-related manuals are available through SunExpress or your local bookstore. Contact your SunSoft representative for information on ordering.

- *PostScript Language Reference Manual, Second Edition*, Adobe® Systems Incorporated
- *PostScript Language Tutorial and Cookbook*, Adobe Systems Incorporated
- *Programming the Display PostScript System with X*, Adobe Systems Incorporated

- *PostScript Language Program Design*, Adobe Systems Incorporated
- *Adobe Type I Font Format*, Adobe Systems Incorporated

Ordering Sun Documents

The SunDocsSM program provides more than 250 manuals from Sun Microsystems, Inc. If you live in the United States, Canada, Europe, or Japan, you can purchase documentation sets or individual manuals using this program.

For a list of documents and how to order them, see the catalog section of SunExpressTM On The Internet at <http://www.sun.com/sunexpress>.

What Typographic Changes Mean

The following table describes the typographic changes used in this book.

Table P-1 Typographic Conventions

Typeface or Symbol	Meaning	Example
AaBbCc123	The names of commands, files, and directories; on-screen computer output	Edit your <code>.login</code> file. Use <code>ls -a</code> to list all files. <code>machine_name%</code> You have mail.
AaBbCc123	What you type, contrasted with on-screen computer output	<code>machine_name%</code> su Password:
<i>AaBbCc123</i>	Command-line placeholder: replace with a real name or value	To delete a file, type <code>rm filename</code> .
<i>AaBbCc123</i>	Book titles, new words or terms, or words to be emphasized	Read Chapter 6 in <i>User's Guide</i> . These are called <i>class</i> options. You <i>must</i> be root to do this.

Shell Prompts in Command Examples

The following table shows the default system prompt and superuser prompt for the C shell, Bourne shell, and Korn shell.

Table P-2 Shell Prompts

Shell	Prompt
C shell prompt	machine_name%
C shell superuser prompt	machine_name#
Bourne shell and Korn shell prompt	\$
Bourne shell and Korn shell superuser prompt	#

What Is x86?

The term “x86” refers to the Intel 8086 family of microprocessor chips, including the Pentium and Pentium Pro processors and compatible microprocessor chips made by AMD and Cynix. In this document, the term “x86” refers to the overall platform architecture, whereas “*Intel Platform Edition*” appears in the product name.

Introduction to the Solaris X Server



This chapter provides information on the Solaris X server. The Solaris X server implements the X Window System client-server model for the Solaris product. The chapter includes information on the following topics:

- Features of the Solaris X server, including supported extensions from the X Consortium and the Display PostScript extension
- Supported and unsupported X11 applications
- OpenWindows™ directory structure

About the Solaris X Server

The Solaris X server, `xSun`, is composed of the X Consortium's X11R6 sample server with the Display PostScript (DPS) imaging system extension, additional X Consortium X extensions, and Sun added value. The Solaris X server is the foundation for the Common Desktop Environment (CDE) and underlies the CDE desktop. The server handles communication between client applications, the display hardware, and input devices. By default, the Solaris X server runs with the CDE `dtlogin` and window manager (`dtwm`), but any X Window System manager that is ICCCM (Inter-Client Communication Conventions Manual) compliant runs with the server. Software developers can write applications for the Solaris environment using the Xlib library or a variety of toolkits, including the Motif toolkit and the Xt toolkit.

Figure 1-1 illustrates the relationship between the Solaris X server, several desktop client applications, the display, and input devices.

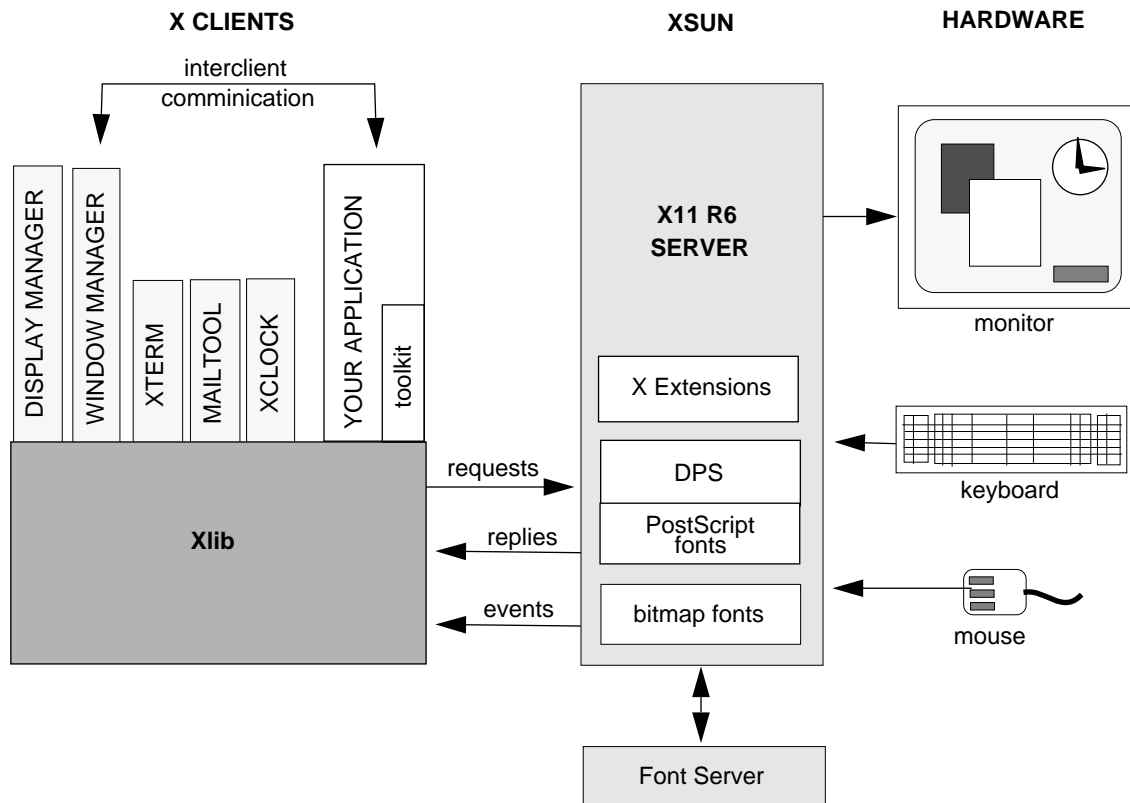

Figure 1-1 Solaris X Server

X11R6 Sample Server

An important component of the Solaris X server is the X11R6 sample server from the X Consortium. The X11R6 sample server was designed and implemented to be *portable*; it hides differences in the underlying hardware from client applications. The sample server handles all drawing, interfaces with device drivers to receive input, and manages off-screen memory, fonts, cursors, and colormaps.

The sample server contains the following parts, or *layers*:

- Device-Independent Layer (DIX) – Dispatches client requests, manages the event queue, distributes events to clients, and manages visible data structures. This layer contains functions that do not depend on graphics hardware, input devices, or the host operating system.
- Device-Dependent Layer (DDX) – Creates and manipulates pixmaps, clipping regions, colormaps, screens, fonts, and graphics contexts. In addition, the DDX layer collects events from input devices and relays them to the DIX layer. This layer contains routines that depend on graphics hardware and input devices the server must accommodate.
- Operating System Layer (OS) – Manages client connections and connection authorization schemes, and provides routines for memory allocation and deallocation. The OS layer contains functions that rely on the host operating system.
- Font Management Library – The font management library enables the server to use font files of different formats and to load fonts from the X font server. The server’s font features are described in detail in Chapter 4, “Font Support.”

Figure 1-2 illustrates the structure of the server. Note that throughout this document, *server* is used interchangeably with the Solaris X server, and *sample server* is used interchangeably with the X Consortium’s X11R6 sample server.

Server Architecture

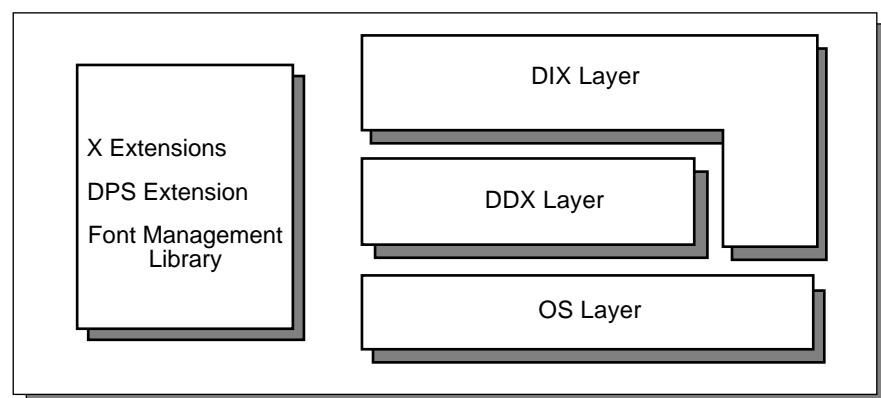

Figure 1-2 Solaris X Server Architecture

DPS Extension

In addition to the X11R6 sample server, the Solaris X server includes the Display PostScript system. DPS provides X applications with the PostScript imaging model and with access to the Adobe Type Library. The Display PostScript system is implemented as an extension to the X Window System as part of the client-server network architecture; the extension is sometimes referred to as *DPS/X*.¹

In the DPS system, the PostScript interpreter is implemented as an extension to the X server, and each application is a client. The application sends PostScript language code to the server through single operator calls, and data can be returned from the server in the form of output arguments. DPS client-server communication is implemented transparently using the low-level communication protocols provided by the X Window System. For more information on the DPS system, see Chapter 2, “DPS Features and Enhancements”.

X Consortium Extensions

The Solaris X server supports X extensions as defined by the X Consortium. These extensions are briefly described in the sections below. The sections provide the specification name for each extension, as well as the associated file name (on `ftp.x.org`) in parentheses. For information on the standard X Extension Mechanism, see *The X Window System Server* and the *Xlib Programming Manual*.

The X Consortium X11 standards referenced in the following sections are readily available to systems on the World Wide Web. The URL is `http://www.rdg.opengroup.org`. The X11 documentation resides in the `/pub/R6untarred/mit/doc/extensions` directory on the `ftp.x.org` machine. Use the file transfer protocol (`ftp`) to download files from this system. If you need help using `ftp`, refer to the `ftp(1)` man page. To determine if your system is connected to the World Wide Web, see your system administrator.

1. This section is based on Chapter 2 of *Programming the Display PostScript System with X* by Adobe Systems Incorporated (Addison-Wesley Publishing Company, Inc., 1993) and is used with the permission of the copyright holder.

X Input Extension

The X Input Extension is Sun's implementation of the X Consortium standard, *X11 Input Extension Protocol Specification* (`/pub/X11/R6.1/xc/doc/specs/Xi/protocol.ms`). This extension controls access to alternate input devices (that is, other than the keyboard and pointer). It allows client programs to select input from these devices independently of each other and independently of the core devices.

Double Buffer Extension

The double buffer extension (DBE) is Sun's implementation of the X Consortium standard. Double-buffering provides flicker-free animation capabilities by allowing applications to show the user only completely rendered frames. Frames are rendered in a non-displayed buffer and then moved into a displayed buffer.

Shape Extension

The Shape Extension is Sun's full implementation of the X Consortium standard, *X11 Nonrectangular Window Shape Extension* (`shape.ms`). This extension provides the capability of creating arbitrary window and border shapes within the X11 protocol.

Shared Memory Extension

The Shared Memory extension is Sun's full implementation of the X Consortium experimental Shared Memory Extension (`mit-shm.ms`). This extension provides the capability to share memory `XImages` and `pixmap`s by storing the actual image data in shared memory. This eliminates the need to move data through the Xlib interprocess communication channel; thus, for large images, system performance increases. This extension is useful only if the client application runs on the same machine as the server.

XTEST Extension

The XTEST extension is Sun's full implementation of the X Consortium proposed standard, *X11 Input Synthesis Extension Proposal* (`xtest1.mm`). This extension provides the capability for a client to generate user input and to control user input actions without a user being present. This extension requires modification to the DDX layer of the server.

Miscellaneous Extension

The MIT-SUNDRY-NONSTANDARD extension was developed at MIT and does not have a standard, or specification, on the `ftp.x.org` machine. This extension handles miscellaneous erroneous protocol requests from X11R3 and earlier clients. It provides a request that turns on bug-compatibility mode so that certain erroneous requests are handled or turns off bug-compatibility mode so that an error for erroneous requests is returned. The extension also provides a request that gets the current state of the mode.

This extension can be dynamically turned on or off with `xset`, or at server startup with `openwin`. See the `xset(1)` and `openwin(1)` man pages, specifically the `-bc` option, for more information.

XC-MISC

This standard X Consortium extension allows an application to recycle XIDs. Some applications create and destroy XIDs so rapidly that they exceed the fixed range of XIDs. Most applications do not need to use this extension. The specification is in `/pub/X11/xc/doc/specs/Xext/xc-misc.ms`

X Imaging Extension

Sun's implementation of X includes the standard X Imaging Extension (XIE); however, it is recommended that you use Sun's XIL™ software instead. XIL uses hardware acceleration where possible to speed up imaging operations. XIL is documented in the *XIL Programmer's Guide*. To view the on-line version of this guide, see the Solaris XIL 1.3 AnswerBook located at the following web site: <http://docs.sun.com>

AccessX

The Solaris X server also supports keyboard features compliant with the American Disabilities Act (ADA). These features are available through an extension to the server, called AccessX. The AccessX extension provides the following capabilities: sticky keys, slow keys, toggle keys, mouse keys, bounce keys and repeat keys. Use the client program `accessx` to enable and disable these capabilities. The `accessx` client controls the toggle, bounce, and repeat keys and their settings. The sticky, slow, and mouse keys can be enabled using shift or other keys. For information on using AccessX, see the *Solaris User's Guide*.

Before running `accessx`, set the `UIDPATH` environment variable to `/usr/openwin/lib/app-defaults/accessx.uid`.

The `accessx` client is part of the `SUNWxwacx` package. To install it, you need to install the All Cluster.

Shared Memory Transport

The Solaris X server includes the Sun extension `SUN_SME`, Sun's implementation of a shared memory transport mechanism. This extension provides the capability of sending client requests to the server via shared memory. Shared memory is used for client requests only. Replies from the server and events are sent via the default transport mechanism. To enable this transport mechanism, set the `DISPLAY` environment variable to `:x.y`, where `x` is the display number, and `y` is the screen number, and set the environment variable `XSUNTRANSPORT` to `shmem`. The size of the segment can be set by setting the environment variable `XSUNSMESIZE` to the desired size in Kbytes. By default, `XSUNSMESIZE` is set to 64.

Visual Overlay Windows

The Solaris X server supports two application programmer's interfaces (APIs) that enable use of overlay windows. An overlay is a pixel buffer (either physical or software-simulated) into which graphics can be drawn. Applications can use overlays to display temporary imagery in a display window. For more information on the overlay APIs, see Chapter 5, "Server Overlay Windows," and Chapter 6, "Transparent Overlay Windows."

X11 Libraries

Table 1-1 lists the X11 libraries. The .so and .a files that comprise these libraries are in /usr/openwin/lib.

Table 1-1 X11 Libraries

Library	Description	Available From the X Consortium	Sun Value Added
libX11	Xlib	Yes	MT safe Dynamic loading of locale Search path includes /usr/openwin, New keysyms
libXau	X Authorization library	Yes	None
libXaw	Athena Widget Set library	Yes	None
libXext	X Extensions library	Yes	Bug fixes, transparent overlays
libXinput	Binary compatibility library for previous input extension	No	Sun library
libXi	Xinput Extension library	Yes	Bug fixes Supports Solaris X extensions
libXmu	X Miscellaneous Utilities library	Yes	Search path includes /usr/openwin
libXol	OLIT library	No	Sun product—see the preface for a list of OLIT manuals (Available from USL)
libXt	Xt Intrinsic library	Yes	None
libxview	XView library	Yes	Sun product donated to X Consortium Bug fixes not included in X11R6 libxview

Applications That Run With the Solaris X Server

You can run the following kinds of applications with the Solaris X server:

- Applications written with the following toolkits:
 - OpenWindows toolkits: OLIT and XView
 - Motif toolkit
 - Xt toolkit

- Applications written for the X protocol
- Applications written for the DPS interface
- SPARC OpenWindows Version 3 X11 applications compiled under SunOS 4.x

Note – The OpenWindows Version 3 X11 applications must adhere to the system Binary Compatibility Package. See the *Binary Compatibility Guide* for more information.

- x86 Applications from Interactive Unix

Applications written with the following interfaces are *not* supported:

- TNT, NeWS, and XVPS
- SunView, SunWindows, and Pixrect

Supported X11 Applications

The Solaris X server supports the following client applications available from the X Consortium. These clients are also included as part of the Solaris environment.

- xterm terminal emulator
- twm window manager
- xdm display manager
- bitmap bitmap editor
- xfd font display utility
- xauth access control program
- xhost access control utility
- xrdb resource control program
- xset user preference setting program
- xsetroot root window appearance setting utility
- xmodmap keyboard control utility
- xlsfonts server font listing utility
- xfontsel font selection utility
- xlswins window listing utility
- xwininfo window information utility
- xlsclients client applications information utility
- xdpyinfo server information display utility
- xprop window and font properties utility

Unsupported Applications

The following are some applications and libraries, all of which are available from the X Consortium, that run on the server but are *not* distributed or supported by Sun:

- Andrew, InterViews
- The `uwm` and `wm` window managers
- The CLX Common Lisp interface
- *contrib* X Consortium clients

OpenWindows Directory Structure

The OpenWindows directory structure, which includes the Solaris X server executable and X11 core distribution libraries, is shown in Figure 1-3 on page 11. Note that `/openwin/etc` is a symbolic link to `/openwin/share/etc`, `/openwin/include` is a link to `/openwin/share/include`, and `/openwin/man` is a link to `/openwin/share/man`. The `/share` directory contains architecture-independent files.

For more information on the X11 libraries in `/openwin/lib`, see page 8.

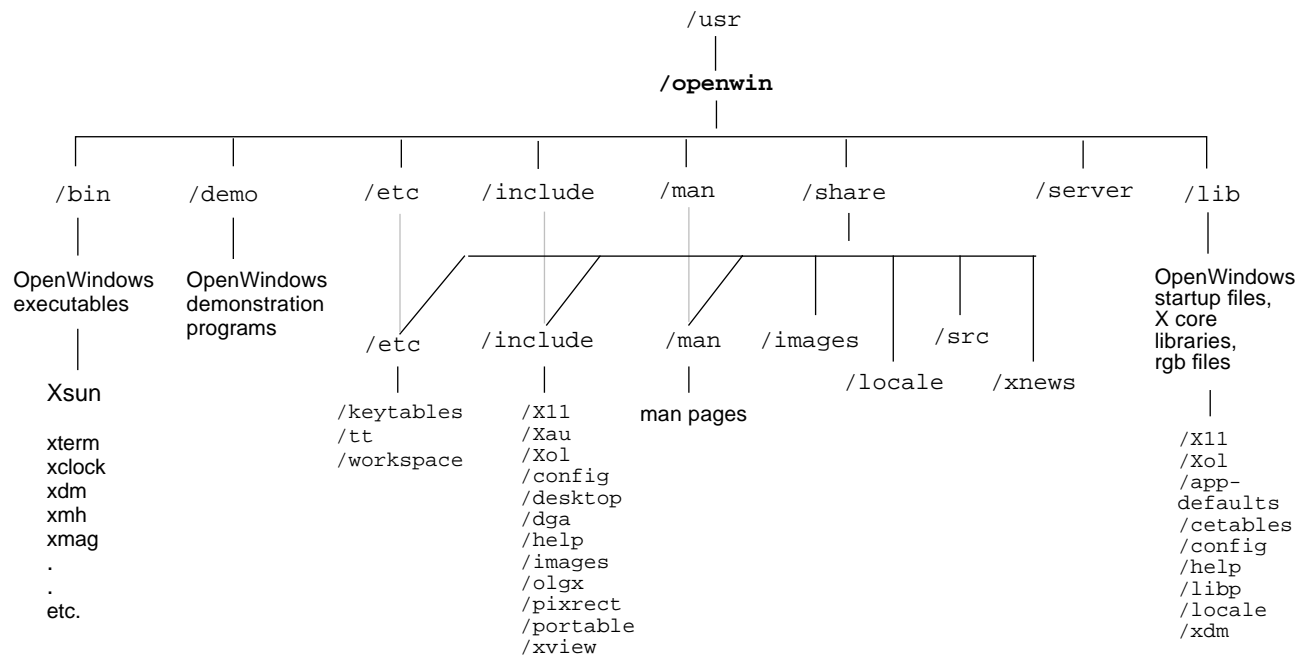

Figure 1-3 OpenWindows Directory Structure

Table 1-2 briefly describes the contents of the top level directories in the OpenWindows directory structure.

Table 1-2 OpenWindows Directories

Directory	Subdirectory	Content
/etc	/keytables	US and international keytables, and keytable.map
	/tt	ToolTalk® data files
	/workspace	/patterns (.xbm files and attributes)
/include	/X11	X11 header files, /DPS, /Xaw, /Xmu, /bitmaps, /extensions
	/Xau	Symbolic link to /include/X11
	/Xol	OLIT header files
	/config	generic.h header file
	/desktop	Classing engine header files

Table 1-2 OpenWindows Directories (Continued)

Directory	Subdirectory	Content
	/dga	dga.h header file
	/help	libhelp header files
	/images	Various bitmap files
	/olgx	olgx header file
	/pixrect	Pixrect header files
	/portable	c_varieties.h and portable.h header files
	/xview	XView header files
/lib	/X11	Server support files, /fonts, and DPS .upr files
	/Xo1	OLIT data files
	/app-defaults	X applications default files
	/cetables	Classing Engine tables
	/config	imake files
	/help	Symbolic link to /locale/C/help
	/libp	Profiles libraries
	/locale	Locale libraries (/C, /iso_8859_1)
	/xdm	Xdm configuration files
/man	/man1, /man1m	OpenWindows command man pages
	/man3	Library man pages, for XView, OLIT, Xt, Xlib, etc.
	/man4	AnswerBook man pages
	/man5	File format man pages
	/man6	Demos man pages
	/man7	Non-command man pages
/server	Server private files for internal use only	
/share	/etc	Location of files in /etc
	/images	/PostScript, /fish, /raster
	/include	Location of files in /include
	/locale	Location of files in /lib/locale

Table 1-2 OpenWindows Directories (Continued)

Directory	Subdirectory	Content
	/man	Location of files in /man
	/src	/dig_samples, /extensions, /fonts, /olit, /tooltalk, /xview
	/xnews	/client

Notes on X11 Programming

Common X11 programming issues are discussed in the following sections.

Compose Key Support

The OpenWindows version of Xlib supports Compose Key processing through calls to `XLookupString`.

For x86 systems – On x86 keyboards, use the Control-Shift-F1 key sequence for the Compose Key functionality.

NumLock Key Support

The OpenWindows version of Xlib supports NumLock Key processing through calls to `XLookupString`. This change does not affect the NumLock processing that exists in XView, OLIT, Motif, or X applications.

For x86 systems – On x86 keyboards, the NumLock Key resides in the top line of the keypad section of the keyboard..

Color Name Database

The color name database provides a mapping between ASCII color names and RGB color values. This mapping increases the portability of color programs and eases programming. Note that this mapping is subjective and has no objective scientific basis.

The source of the database is `/usr/openwin/lib/X11/rgb.txt`. This file is identical to the one provided in X11R6 from the X Consortium. `rgb.txt` is compiled into the `dbm(3)` database files, `rgb.dir` and `rgb.pag`. When the server starts up, it builds an internal representation of `rgb.dir` and `rgb.pag` used to map a color name to a color value.

X11 clients use `XLookupColor` or `XAllocNamedColor` to map a color name to a color value. The color name string passed to these routines is converted to lowercase before it is looked up in the database.

Color Recommendations

This section contains recommendations for using the Solaris X server color support facilities. Use these hints to maximize portability and color sharing:

- Do not rely on the locations of black and white in the default `PseudoColor` colormap. Always use `XAllocColor` to allocate a pixel for rendering.

Note – Do not rely on black and white being in certain pixel locations. Future versions of the Solaris X server and the servers of other vendors may have these colors located in different positions than the current server. For maximum portability and compatibility, always write X11 clients so that they use the `XAllocColor` function to allocate desired colors for rendering.

- Do not use a visual before you have checked on all supported visual types, using `XGetVisualInfo` or `XMatchVisualInfo`. Note that `XGetVisualInfo` is the recommended function to use because it has the ability to distinguish between visuals of the same class and depth.
- To reduce colormap flashing, it is usually a good policy to try to first allocate colors from the default colormap. Only when this allocation fails should you create a private colormap.
- For more hints on writing portable X11 color clients, see “Hints for Windows Programming With Visuals” on page 37.

Further Reading

There are numerous books on all aspects of X and the X Window System. For more information on the X Window System, see page xvii of the preface for a list of recommended books available through SunExpress and your local book store. For more information on the Solaris X server and the X Consortium sample server, see the following manual pages:

- `xsun(1)` – Solaris X server
- `xserver(1)` – the X Consortium sample server
- `openwin(1)` – OpenWindows startup command

DPS Features and Enhancements



This chapter provides information on the Display PostScript (DPS) extension to the Solaris X server. The following topics are briefly discussed:

- Overview information on the DPS system
- Solaris font enhancements to DPS
- DPS security issues
- DPS compositing operators

About DPS

The Display PostScript system displays graphical information on the computer screen with the same PostScript language imaging model that is a standard for printers and typesetters.¹ The PostScript language makes it possible for an X application to draw lines and curves with perfect precision, rotate and scale images, and manipulate type as a graphic object. In addition, X applications that use the Display PostScript system have access to the entire Adobe Type Library.

1. This section is based on Chapter 4 of *Programming the Display PostScript System with X* by Adobe Systems Incorporated (Addison-Wesley Publishing Company, Inc., 1993) and is used with the permission of the copyright holder.

Device and resolution independence are important benefits of PostScript printers and typesetters. The Display PostScript system extends these benefits to interactive displays. An application that takes advantage of the DPS system will work and appear the same on any display without modification to the application program.

How DPS Works

The DPS system has several components, including the PostScript interpreter, the Client Library, and the `pwrap` translator. The Client Library is the link between an application and the PostScript interpreter.

Each application that uses the DPS extension creates a *context*. A context can be thought of as a virtual PostScript printer that sends its output to a window or an offscreen pixmap. It has its own set of stacks, input/output facilities, and memory space. Separate contexts enable multiple applications to share the PostScript interpreter, which runs a single process in the server.

Although the DPS system supports multiple contexts for a single application, one context is usually sufficient for all drawing within an application. A single context can handle many drawing areas. There are exceptions, however, when it is preferable to use more than one context in a client. For example, a separate context might be used when importing Encapsulated PostScript (EPS) files. This simplifies error recovery if an included EPS file contains PostScript errors.

An application draws on the screen by making calls to Client Library procedures. These procedures generate PostScript language code that is sent to the PostScript interpreter for execution. In addition to the Client Library, the DPS system provides the `pwrap` translator. It takes PostScript language operators and produces a C-language procedure—called a wrap—that can then be called from an application program.

The PostScript interpreter handles the scheduling associated with executing contexts in time slices. The interpreter switches among contexts, giving multiple applications access to the interpreter. Each context has access to a private portion of PostScript virtual memory space (VM). An additional portion of VM, called *shared VM*, is shared among all contexts and holds system fonts and other shared resources. *Private VM* can hold fonts private to the context.

Figure 2-1 shows the components of DPS and their relationship to X.

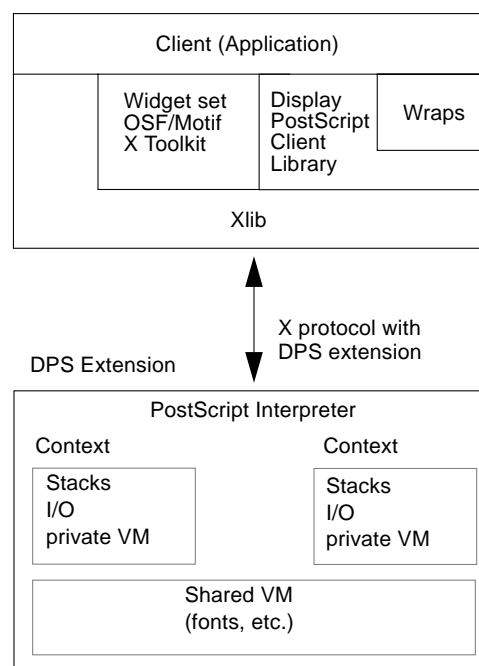

Figure 2-1 DPS Extension to X

An application interacts with the DPS system in the following manner:

1. The application creates a PostScript execution context and establishes a communication channel to the server.
2. The application sends Client Library procedures and wraps to the context and receives responses from it.
3. When the application exits, it destroys the context and closes the communications channel, freeing resources used during the session.

The structure of a context is the same across all DPS platforms. Creating and managing a context, however, can differ from one platform to another. The *Client Library Reference Manual* and *Client Library Supplement for X* contain information on contexts and the routines that manipulate them, and *Display PostScript Toolkit for X* contains utilities for Display PostScript developers.

DPS Font Enhancements in the Solaris Server

The Solaris X server includes the following font enhancements to the DPS system:

- Support for F3 Latin and Asian fonts
- Support for TrueType fonts

See Chapter 4, “Font Support,” for more information.

DPS Libraries

Table 2-1 lists the DPS libraries. The .so and .a files that comprise these libraries are located in the /usr/openwin/lib and /usr/openwin/lib/libp directories. For information on these libraries, see *Programming the Display PostScript System with X and PostScript Language Reference Manual*.

Table 2-1 DPS Libraries

Library	Description
libdps	DPS Client library
libdpstk	DPS Toolkit library
libpsres	PostScript Language Resource Location library
libdpstkXm	DPS Motif Toolkit library

Adobe NX Agent Support

The context creation routines (XDPSCreateSimpleContext and XDPSCreateContext) in libdps attempt to contact the DPS NX agent if they are unable to connect to the DPS/X extension. The NX client must be started manually, usually during the boot or X startup process.

The Adobe DPS NX agent, which is available from Adobe Systems Inc., is a separate process from the X server and the DPS/X client. When connected to the DPS NX agent, the client’s DPS calls are intercepted and converted into standard X Protocol requests. Thus, a DPS client can run on an X server that does not natively support the DPS extension.

DPS Security Issues

The Solaris environment provides, and in some cases exceeds, the X Consortium's X11R5 sample server security levels. In particular, DPS programmers should be aware of two DPS-specific security features: PostScript file operators' inability to access system files, and secure context creation. These features are described below.

System File Access

The PostScript language provides file operations that allow users to access system devices such as disk files. This presents a serious security problem. In the Solaris environment, you cannot—by default—use PostScript file operators to open or otherwise access a system file.

For applications, the client rather than the server should perform necessary file operations. Thus, the client does not need all the same access privileges that the server needs. If you want PostScript file operators to access system files, start the server with the `-dpsfileops` option (see the `Xsun(1)` man page). If you attempt to access system files without specifying `-dpsfileops`, you will get a PostScript `undefinedfilename` error. This issue is particularly important in the CDE or `xdm` environment, as the server process is owned by a super-user.

Secure Context Creation

DPS contexts normally have access to global data. This allows a context to look into the activities of another context. For example, one context could intercept a document that another context is imaging. This section describes how to create secure contexts in the Solaris environment.

Section 7.1.1, "Creating Contexts," in the *PostScript Language Reference Manual, Second Edition* describes three ways that contexts can share VM:

1. "Local and global VM are completely private to the context." This capability is new with Level 2, and a context created this way is called a *secure context*.
2. "Local VM is private to the context, but global VM is shared with some other context." This is the normal situation for contexts created with `XDPSCreateContext` and `XDPSCreateSimpleContext`.

3. “Local and global VM are shared with some other context.” This is the situation for contexts created with `XDPSCreateContext` and `XDPSCreateSimpleContext` when the `space` parameter is not `NULL`.

To create a secure context, use `XDPSCreateSecureContext` as shown below:

```
XDPSCreateSecureContext DPSTextProc XDPSCreateSecureContext(dpy,
    drawable, gc, x, y, eventmask, grayramp, ccube, actual,
    textProc, errorProc, space)
Display *dpy;
Drawable drawable;
GC gc;
int x;
int y;
unsigned int eventmask;
XStandardColormap *grayramp;
XStandardColormap *ccube;
int actual;
DPSTextProc textProc;
DPSErrorProc errorProc;
DPSSpace space;
```

All parameters have the identical meaning to those in `XDPSCreateContext`, but the context being created has its own private global VM. If the `space` parameter is not `NULL`, it must identify a space created with a secure context. A space created with a secure context cannot be used for the creation of a nonsecure context. Specifying a nonsecure space with a secure context or a secure space with a nonsecure context generates an access error.

When DPS Encounters Internal Errors

DPS conducts consistency checks during execution. In the rare event that it encounters internal errors, DPS applications will not be able to connect to the server. If this happens, you must restart the Solaris environment. If a client tries to connect to a server with the DPS extension in this state, the following error message sometimes appears:

```
XError: 130  
Request Major code 129 (Adobe-DPS_Extension)
```

How To Access Information From Adobe

The following information is readily available from Adobe's public access file server: source code examples, Adobe Metric Font (AMF) files, documentation, PostScript printer description (PPP) files, and press releases. You can obtain this information if you have access to the Internet or UUCP electronic mail.

If you have access to the Internet, use the file transfer protocol (`ftp`) program to download files from the `ftp.mv.us.adobe.com` machine. Read the `README.first` file for information on the archived files. For details on obtaining information from Adobe by electronic mail, see the "Public Access File Server" section in the preface of *Programming the Display PostScript System with X*.

DPS Compositing Operators

Warning – The operators defined in this section are extensions to the Display PostScript language. They are not part of the standard DPS and thus are not available in all DPS implementations. An application that depends on these operators is not portable and cannot display on servers that do not support these operators.

Compositing is an OpenStep™ extension to the Display PostScript system. Compositing enables separately rendered images to be combined into a final image. It encompasses a wide range of imaging capabilities:

- It provides a means for simply copying an image as is from one place to another with PostScript.
- It allows two images to be added together so that both appear in the composite superimposed on each other.
- It defines a number of operations that take advantage of transparency in one or both images that are combined. When the images are composited, the transparency of one image can let parts of the other image show through.

Compositing can be used for copying within the same window, as during scrolling, or for taking an image rendered in one drawable and transferring it to another. In OpenStep applications, images are often stored in pixmaps and composited into windows as they are needed.

When images are partially transparent, they can be composited so that the transparent sections of one image determine what the viewer sees of the other. Each compositing operation uses transparency in a different way. In a typical operation, one image provides a background or foreground for the other. When parts of an image are transparent, it can be composited over an opaque background, which will show through transparent “holes” in the image on top. In other operations, transparent sections of one image can be used to “erase” matching sections of the images it is composited with. In most operations, the composite is calculated from the transparency of both images.

Compositing with transparency can achieve a variety of interesting visual effects. A partially transparent, uniformly gray area can be used like a pale wash to darken the image it is composited with. Patches of partially

transparent gray can add shadows to another image. Repeated compositing while slowly altering the transparency of two images can dissolve one into another. Or an animated figure can be composited over a fixed background.

Before images can be composited, they must be rendered. To take advantage of transparency when compositing, at least one of the images needs to be rendered with transparent paint.

The following PostScript program fragment shows the use of the compositing operators. The program creates two simple images and composites them. The first image, the destination, is a 0.8 gray triangle on a white background; the second, the source, is a 0.6 gray triangle on a transparent background.

```
% Create the Destination triangle
  0.8 setgray
  100 100 moveto
  100 0 rlineto
  0 -100 rlineto
  fill

% Make the background of the source transparent
  0 setalpha
  0 0 100 100 rectfill

% Draw the Source triangle
  1 setalpha
  0.6 setgray
  0 0 moveto
  0 100 rlineto
  100 0 rlineto
  fill

% Compute the result
  0 0 100 100 null 100 0 Sover composite
```

The eighth operand to the composite operator, *Sover*, defines how the source and destination pixels are combined. In the example, the opaque parts of the source image are placed over the destination image. The resulting image looks like Figure 2-2 on page 26.

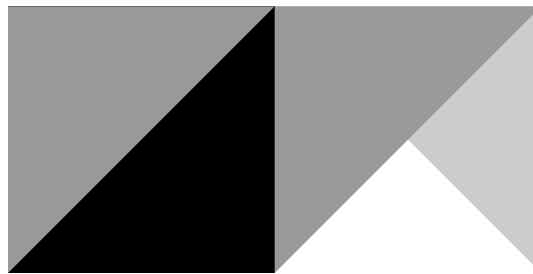

Figure 2-2 Compositing Operator Example Program

Operator Descriptions

This section describes the new DPS operators. The information is provided in the format used in the PostScript manuals *PostScript Language Reference Manual* and *Programming the Display PostScript System with X*.

setalpha *coverage* **setalpha**

Sets the *coverage* parameter in the current graphics state to *coverage*. *coverage* should be a number between 0 and 1, with 0 corresponding to transparent, 1 corresponding to opaque, and intermediate values corresponding to partial coverage. The default value is 1. This establishes how much background shows through for purposes of compositing. If the coverage value is less than 0, the coverage parameter is set to 0. If the value is greater than 1, the coverage parameter is set to 1.

The coverage value affects the color painted by PostScript marking operations. The current color is pre-multiplied by the alpha value before rendering. This multiplication occurs after the current color has been transformed to RGB space.

Errors **stackunderflow, typecheck**

See also **composite, currentalpha**

currentalpha - *currentalpha coverage*

Returns the coverage parameter of the current graphics state.

Errors **None**

See also **composite, setalpha**

composite *srcx srcy width height srcgstate destx desty op composite*

Performs the compositing operation specified by *op* between pairs of pixels in two images, a source and a destination. The source pixels are in the drawable referred to by the *srcgstate* graphics state, and the destination pixels are in the drawable specified by the current graphics state. If *srcgstate* is `NULL`, the current graphics state is assumed.

The rectangle specified by *srcx*, *srcy*, *width*, and *height* defines the source image. The outline of the rectangle may cross pixel boundaries due to fractional coordinates, scaling, or rotated axes. The pixels included in the source are all those that the outline of the rectangle encloses or enters.

The destination image has the same size, shape, and orientation as the source; *destx* and *desty* give destination's location image compared to the source. Even if the two graphic states have different orientations, the images will not; `composite` will not rotate images.

Both images are clipped to the frame rectangles of the respective drawables. The destination image is further clipped to the clipping path of the current graphics state. The result of a `composite` operation replaces the destination image.

op specifies the compositing operation. The color of each destination image pixel (alpha value) after the operation, *dst'* (*dstA'*), is given by:

$$dst' = src * Fs(srcA, dstA, op) + dst * Fd(srcA, dstA, op)$$

$$dstA' = srcA * Fs(srcA, dstA, op) + dstA * Fd(srcA, dstA, op)$$

where *src* and *srcA* are the source color and alpha values, *dst* and *dstA* are the destination color and alpha values, and *Fs* and *Fd* are the functions given in Table 2-2 on page 28.

The choices for the `composite` *op* are given in Table 2-2. See Figure 2-3 on page 29 for the result of each operation.

Errors **rangecheck, stackunderflow, typecheck**
See also **compositerect, setalpha, setgray, sethsbcolor, setrgbcolor**

Table 2-2 Factors of the Compositing Equation

Op	F_s	F_d
Clear	0	0
Copy	1	0
Sover	1	1 - srcA
Sin	dstA	0
Sout	1 - dstA	0
Satop	dstA	1 - srcA
Dover	1 - dstA	1
Din	0	srcA
Dout	0	1 - srcA
Datop	1 - dstA	srcA
Xor	1 - dstA	1 - srcA
PlusD¹	N/A	N/A
PlusL²	1	1

1. PlusD does not follow the general equation. The equation is $dst' = (1 - dst) + (1 - src)$. If the result is less than 0 (black), then the result is 0.
2. For PlusL, the addition saturates. That is, if $(src + dst) > \text{white}$, the result is white.

Figure 2-3 on page 29 shows the result of the compositing operations.

Operation	Destination after	
		<div style="display: flex; justify-content: space-around; align-items: center;"> <div style="text-align: center;"> <p>Source</p> </div> <div style="text-align: center;"> <p>Destination before</p> </div> </div>
Copy		Source image.
Clear		Transparent.
PlusD		Sum of source and destination images, with color values approaching 0 as a limit.
PlusL		Sum of source and destination images, with color values approaching 1 as a limit.
Sover		Source image wherever source image is opaque, and destination image elsewhere.
Dover		Destination image wherever destination image is opaque, and source image elsewhere.
Sin		Source image wherever both images are opaque, and transparent elsewhere.
Din		Destination image wherever both images are opaque, and transparent elsewhere.
Sout		Source image wherever source image is opaque but destination image is transparent, and transparent elsewhere.
Dout		Destination image wherever destination image is opaque but source image is transparent, and transparent elsewhere.
Satop		Source image wherever both images are opaque, destination image wherever destination image is opaque but source image is transparent, and transparent elsewhere.
Datop		Destination image wherever both images are opaque, source image wherever source image is opaque but destination image is transparent, and transparent elsewhere.
Xor		Source image wherever source image is opaque but destination image is transparent, destination image wherever destination image is opaque but source image is transparent, and transparent elsewhere.

Figure 2-3 Results of Compositing Operations

compositerect *destx desty width height op compositerect -*

In general, this operator is the same as the composite operator except that there is no real source image. The destination is in the current graphics state; *destx*, *desty*, *width*, and *height* describe the destination image in that graphics state's current coordinate system. The effect on the destination is as if there were a source image filled with the color and coverage specified by the graphics state's current color and coverage parameters. *op* has the same meaning as the *op* operand of the composite operator; however, one additional operation, **Highlight**, is allowed.

Highlight turns every white pixel in the destination rectangle to light gray and every light gray pixel to white, regardless of the pixel's coverage value. Light gray is defined as 2/3. Repeating the same operation reverses the effect. (On monochrome displays, **Highlight** inverts each pixel so that white becomes black, black becomes white.)

Note – The **Highlight** operation doesn't change the value of a pixel's coverage component. To ensure that the pixel's color and coverage combination remains valid, **Highlight** operations should be temporary and should be reversed before any further compositing.

For **compositerect**, the pixels included in the destination are those that the outline of the specified rectangle encloses or enters. The destination image is clipped to the frame rectangle and clipping path of the window in the current graphics state.

Errors **rangecheck, stackunderflow, typecheck**

See also **composite, setalpha, setgray, sethsbcolor, setrbgcolor**

dissolve *srcx srcy width height srcgstate destx desty delta dissolve -*

The effect of this operation is a blending of a source and a destination image. The first seven arguments choose source and destination pixels as they do for composite. The exact fraction of the blend is specified by *delta*, which is a floating-point number between 0.0 and 1.0. The resulting image is:

$$\text{delta} * \text{source} + (1-\text{delta}) * \text{destination}$$

If *srcgstate* is null, the current graphics state is assumed.

Errors **stackunderflow, typecheck**

See also **composite**

The values of the composite *op* are available for applications in the PostScript **systemdict**. The definitions are as follows:

/Clear 0 def

/Copy 1 def

/Sover 2 def

/Sin 3 def

/Sout 4 def

/Satop 5 def

/Dover 6 def

/Din 7 def

/Dout 8 def

/Datop 9 def

/Xor 10 def

/PlusD 11 def

/Highlight 12 def

/PlusL 13 def

Implementation Notes and Limitations

Partially Transparent Alpha

Alpha values that are not completely opaque (1) or completely transparent (0) should be used with caution. Compositing operations with partial transparency yield the highest image quality only when a large number of colors are available in the DPS color cube and gray ramp. That is, image

quality is best with a 24-bit TrueColor or 8-bit StaticGray visual, and image quality will be poor with an 8-bit PseudoColor visual. In addition, the performance of compositing operations is greatly reduced for partially transparent pixels due to the extra computation required in these cases.

Indexed Color Visuals

For best results with the **Highlight** *op*, the number of colors in the DPS context's gray ramp should be such that

```
fract(((float) numgrays - 1)* 2. / 3.) == 0
```

In other words, (numgrays = 4, 7, 6, 8, 16, ...). This ensures that the color 2/3 gray is not halftoned.

Given the limited number of colors usually available in the DPS color cube and gray ramp, images with alpha values that are not completely opaque (1) or completely transparent (0) should be avoided to obtain best image quality.

Compositing operations are only defined for pixels values that are in the gray ramp or color cube specified by the *gstate*. Compositing pixels with values outside the color cube and gray ramp may not yield expected results.

Monochrome Displays

The results of compositing operations for 1-bit drawables that have alpha values that are not equal to 0 or 1 is undefined.

The *op* **Highlight** inverts the color of the pixel on a 1-bit drawable.

Interaction with X Drawing Operations

Drawables that have been rendered to with non-opaque alpha have additional pixel storage associated with them, called the alpha channel. X Window system operations do not affect the alpha channel, with the following exceptions:

- When windows with alpha channel are exposed, if the window has an X background defined (background != None), when the background is painted, the alpha component of the exposed pixels is painted with alpha = 1.
- When a window is resized, the alpha channel storage is resized.

Destroying the Alpha Channel

The **erasepage** operator paints the current drawable of the graphics state with opaque white. Thus, the alpha values for all pixels in the drawable are equal to 1, and the alpha channel storage is destroyed.

Drawables with Unequal Depths

Compositing drawables with unequal depths is undefined.

Visuals on the Solaris X Server

This chapter discusses X window visuals on the Solaris X server. The chapter includes information on the following:

- Default visual
- Visuals on multi-depth devices
- Gamma-corrected visuals
- Hints on window programming with visuals

About Visuals

A display device can support one or more display formats. In the X window system, the display formats supported by the window server are communicated to client applications in the form of *visuals*. A visual is a data structure describing the display format a display device supports.

When an X11 client creates a window, it specifies the window's visual. The visual describes the display characteristics for each pixel in the window. In other words, a window's visual instructs the display device's video hardware how to interpret the value of the window's pixels.

For each display device configured into the system, there is an X11 screen. For each screen, a list of supported visuals is exported by the server to client applications. This list of visuals tells the client application which display formats are available for creating windows.

The visuals exported by the server for a display screen are not fixed; they depend on the screen's device handler. Since the exporting of visuals is under the control of the device handler, client applications must be prepared to deal with a wide variety of visuals, including visuals with depths other than those that have previously been common, such as 1, 8, and 24 bits. Visuals with depths of 4, 16, and odd depths may not be exported, and clients must be prepared to handle them.

Client applications can query the list of supported visuals for a screen by calling the Xlib routines `XGetVisualInfo(3)` or `XMatchVisualInfo(3)`, and can query the list of supported visuals using the utility `xdpvinfo(1)`. For general information on color and visuals in X11, see the X11 documentation listed in the preface to this manual.

Default Visual

For each X11 screen, one of the exported visuals for the screen is designated the *default visual*. The default visual is the visual assigned to the screen's root window, and this visual is the visual that most applications use to create their windows. When a client application starts, its windows are assigned the default visual unless the application specifies a different visual.

The *built-in default visual* is the visual hard-coded in the Solaris X server. For each screen, there is a default visual that depends on the characteristics of the display device for that screen. This is the default visual unless you specify a different default visual when you run `openwin(1)`.

Users can change the default visual that window server advertises in the connection block. One reason for this is to force client programs that cannot run in the default visual to run in a specific visual. For example, on a 24-bit device that has the TrueColor visual as its default visual, an application that cannot run with 24-bit color may run on a PseudoColor visual.

For developers on multi-depth devices, changing the default visual is a useful way to test that your application works in different configurations. For information on how to change the default visual, see the `xsun(1)` man page. The default visual and the list of supported visuals exported by the server can be examined from X11 using `XGetVisualInfo(3)`.

Visuals on Multi-Depth Devices

The Solaris X server supports devices that can display windows of more than one pixel depth simultaneously. These devices are called *multi-depth* devices. Since most of these devices are implemented with separate groups of bit planes for each depth, the term *multiple plane group* (MPG) device is often used for these devices.

For each depth, there might be one or more visuals exported. For most MPG devices, windows can be created using any of the exported visuals. For applications that prefer a TrueColor visual, the developer should determine whether the TrueColor visual is available, since it may be available even if PseudoColor is the default visual.

Hints for Windows Programming With Visuals

This section discusses various issues that may arise when programming X11 applications for devices that support more than one visual.

Default Visual Assumptions

A common mistake in programming an X11 client is to assume that the default visual has an indexed class (for example, PseudoColor or StaticColor). It is possible for the default visual to be 24-bit TrueColor on some devices. Clients expecting to run on these devices must be prepared to handle this type of default visual.

Other common programming mistakes with visuals are:

- Assuming the default depth is 8
- Assuming the colormap is writable
- Using a default visual that is not appropriate rather than searching for an appropriate visual using `XGetVisualInfo`

If the device does not support a visual requested by a client, the following error message is returned. In this error message, # represents the depth number requested, and *n* represents the requested display device. If this message is returned for a supported visual/device combination as indicated in Table A-1 on page 100, then an installation problem exists.

```
Error: cannot provide a default depth # for device /dev/fbs/n
```

In general, client applications may need to be modified to make them more portable in the presence of different default visual types.

Setting the Border Pixel

When creating a window with a visual that is not the default visual, applications must set the `border_pixel` value in the window attribute structure, or a `BadMatch` error occurs. This is a common programming error that may be difficult to debug. For information on setting the border pixel, see the `XCreateWindow` man page.

Note - If you are experiencing improper graphics and double-buffering performance (such as lack of acceleration), OpenWindows might not have been installed as `root`.

Gamma-Corrected Visuals

The linearity attribute of a visual describes the intensity response of colors it displays. On a cathode ray tube (CRT) monitor, the colors displayed are actually darker than the colors requested. This darkening is caused by the physics of monitor construction. Some devices support visuals that compensate for this darkening effect. This is called *gamma correction*.

Gamma correction is done by altering colors coming out of the frame buffer with the inverse of the monitor's response. Because the overall intensity of a gamma-corrected visual is a straight line, a gamma corrected visual is called a *linear* visual; a visual that is not gamma corrected is called a *nonlinear* visual.

Linearity is not a standard X11 attribute for visuals. However, some applications require a linear visual to avoid visible artifacts. For example, a graphics application using antialiased lines may produce objectionable “roping” artifacts if it does not use a linear visual. This kind of application is called a *linear application*. An application requiring a nonlinear visual for best display of colors is called a *nonlinear application*. Most X11 applications are nonlinear applications.

On most devices, the linearity of default visuals is nonlinear. Therefore, linear applications should not depend on the default and should always explicitly search for a linear visual. Similarly, it is a good idea for nonlinear applications to explicitly search for a nonlinear visual. Since this is typically the default on most devices, it is not as critical, but it is still a good policy to do so.

To determine whether a visual is linear, applications can use the interface `XSolarisGetVisualGamma(3)`. For more information on gamma correction, refer to *Fundamentals of Computer Graphics* by Foley and Van Dam.

Finding a Linear Visual

Linearity of a visual can be determined in Solaris by querying the visual’s gamma. This is done by calling `XSolarisGetVisualGamma(3)`. If the gamma value is equal to (or close to) 1.0, the visual is linear. Otherwise, it is nonlinear. A good rule-of-thumb for the closeness tolerance is 10%. To use the `XSolarisGetVisualGamma` API, the application must be linked with the Solaris `libXmu`.

Code Example 3-1 on page 40 is an example of selecting the best visual for a typical XGL™ 3D linear application. In this example, the application uses a nonlinear visual if a linear one cannot be found. This is only one possible visual selection policy.

Note – If the gamma of any visual on the device is changed, either through reconfiguration or calibration, the window system should be restarted. Otherwise, applications using `XSolarisGetVisualGamma` that are already running will not detect the change and may use the wrong visual.

Code Example 3-1 3D Linear Visual Selection

```

/*
** Returns the visual of the given depth, class and linearity,
** or NULL if not found.
*/
Visual *
match_visual (Display *dpy, int screen, int depth, int class,
              Bool wantLinear)
{
    XVisualInfo template;
    XVisualInfo *vinfo, *vi;
    int nitems, isLinear, i;
    double gamma;

    template.screen = screen;
    template.depth = depth;
    template.class = class;
    if (!(vinfo = XGetVisualInfo(dpy, VisualScreenMask |
                               VisualDepthMask | VisualClassMask,
                               &template, &nitems)) || nitems <= 0) {
        return (NULL);
    }

    for (i = 0, vi = vinfo; i < nitems; i++, vi++) {
        if (XSolarisGetVisualGamma(dpy, screen, vi->visual, &gamma)
            == Success) {
            /*
            ** A good rule of thumb for linearity of a visual is
            ** whether the gamma is within 10% of 1.0.
            */
            isLinear = (gamma >= 0.9 && gamma <= 1.1);
            if ((wantLinear && isLinear) || (!wantLinear && !isLinear)) {
                Visual *visual = vi->visual;
                XFree(vinfo);
                return (visual);
            }
        }
    }

    XFree(vinfo);
    return (NULL);
}

```

Here is the main routine of the example:

```
main ()
{
    Visual vis;
    ...

    if ((vis = match_visual(display, screen, 24, TrueColor, True)) {
        fprintf(stderr, "Found a linear 24-bit TrueColor visual\n");
        visualClass = TrueColor;
        depth = 24;
    }
    else if ((vis = match_visual(display, screen, 24, TrueColor, False)){
        fprintf(stderr, "Found a nonlinear 24-bit TrueColor visual\n");
        visualClass = TrueColor;
        depth = 24;
    }
    else if ((vis = match_visual(display, screen, 8, PseudoColor, False)){
        fprintf(stderr, "Found a nonlinear 8-bit PseudoColor visual\n");
        visualClass = PseudoColor;
        depth = 8;
    }
    else {
        fprintf(stderr, "Cannot match 24 or 8 bit visual\n");
        exit(1);
    }
    ...
}
```

Visual Selection Alternatives

The above code example illustrates only one possible visual selection policy. Other policies can be implemented. It is recommended that applications be written to handle a wide variety of visual configurations. Some devices, for example the GX, do not have any linear visuals. Other devices have only a single linear 24-bit TrueColor visual. Other types of devices may support both linear and nonlinear visuals at the same time. In general, the most prudent way to write a portable application is to deal gracefully with all these configurations. This may involve printing a warning message if the visual of the desired linearity is not found. Or, if a linear application cannot find a linear visual, a useful trick is to manually darken in the application the colors given

to X11. This is tantamount to performing your own gamma correction. The gamma value returned by `XSolarisGetVisualGamma` can be used to determine how much to darken the colors.

Note - `XSolarisGetVisualGamma` is a *Public* interface of Solaris and is fully supported. In the future, a color management system may also provide this functionality. When this occurs, this will become the preferred way of getting this information. But until then, `XSolarisGetVisualGamma` should be used. When this color management system is introduced, applications using `XSolarisGetVisualGamma` will continue to run with no modification and will actually benefit from the increased accuracy of the color management system.

Font Support



This chapter provides information on font support in the Solaris X server. The chapter includes information on the following topics:

- X font server
- Available font formats
- Outline and bitmap fonts
- Location of fonts

Font Support in the Solaris X Server

The Solaris X Window System provides font support in both the X11 server and the Display PostScript (DPS) extension. Font formats from numerous vendors can be used to display text in English or foreign languages, including Asian languages. Symbol fonts can be used to display mathematical equations. The Solaris environment provides 55 Latin fonts for west European text and two symbol fonts. Other fonts can also be added to the system using the Font Administrator GUI or command line tools distributed with Solaris.

X Font Server

The Solaris X server can be a client of the X font server `xfss`. The X font server renders fonts for the X server. The Solaris X font server supports the same fonts as the standard X font server, plus TrueType fonts from Sun. It does not support Sun's proprietary F3 font format. Support for Type 1 fonts is provided via the Type 1 interpreter donated to the X Consortium.

`xfss` can be started manually or automatically. For more information on this command, see the `xfss(1)` man page.

Available Font Formats

Fonts from different vendors come in different formats. Table 4-1 and Table 4-2 list the various font formats, their vendors, and the associated file types supported by the Solaris environment. Table 4-1 lists outline fonts; Table 4-2 lists bitmap fonts.

Table 4-1 Outline Font Formats

Font Format	Vendor	File Type
TrueType	Various foundries	.ttf
Type1 (ASCII)	Adobe and various foundries	.pfa
Type1 (binary)	Adobe and various foundries	.pfb
Type 3	Adobe and various foundries	.ps
Speedo	Bitstream	.spd
F3	SunSoft	.f3b

Table 4-2 Bitmap Font Formats

Font Format	Vendor	File Type
Portable compiled format	MIT	.pcf
Bitmap distribution format	Adobe	.bdf
Big Endian prebuilt format	Adobe (for sparc)	.bepf
Little Endian prebuilt format	Adobe (for x86 and ppc)	.lepfb

The fonts provided by the Solaris X server are located in the `/usr/openwin/lib/X11/fonts` directory. For more information on the directory structure, see “Locating Fonts” on page 48.

The Solaris environment is configured so that most X11 fonts are also available in DPS (see Table 4-3). DPS supports a slightly different set of fonts than those supported by X11.

Table 4-3 Font File Availability

Font Format	Available in X11	Available in DPS
TrueType	Yes	Yes
Type1 outline fonts-ASCII	Yes	Yes
Type1 outline fonts-binary	Yes	Yes
Type 3	Yes	Yes
Speedo	Yes	No
F3	Yes	Yes
Portable compiled format	Yes	Yes
Bitmap distribution format	Yes	No
Big Endian prebuilt format	No	Yes
Little Endian prebuilt format	No	Yes

Optional Font Package

Fonts needed by end-user applications are installed with the End-User Cluster. However, some unusual applications may need fonts in the Developer Cluster. For these applications, the package to add is the SUNWxwoft package. It is not necessary to install the entire Developer Cluster.

Associated Files

The Solaris environment provides files with these extensions. They are not intended to be edited.

- `.afm` Adobe Font Metrics files read by client for kerning information

- `.map` F3 files read by X11 and DPS for encoding purposes
- `.trans` F3 files read by DPS for composite font construction
- `.ps` PostScript Files for composite font and PostScript resource construction
- `.enc` Encoding files used by X11 and DPS
- `.upr` Display PostScript resource files
- `.ttmap` Encoding file for TrueType fonts

Outline and Bitmap Fonts

Solaris supports two types of font representation: *outline* fonts and *bitmap* fonts. To display a letter from an outline font, the server scales and rotates only the outline of the character. This repositioned outline is then *rendered* into pixel form (bitmap) for display on the screen. This rendered bitmap is also stored in the glyph cache for reuse.

Because certain font sizes occur frequently, they are also kept in separate files in pre-rendered bitmap form. This saves the server from having to scale and render them. However, the resulting bitmap fonts can be displayed in only one size and orientation. Some of the fonts have also been hand-tuned to look better and be more readable. As they are encountered, these bitmaps are also placed in the glyph cache. The recommended bitmap format is the portable compiled format (`.pcf`).

The `/usr/openwin/bin` directory contains the following tools to convert fonts between the outline and bitmap font representation, as well as between various bitmap formats. See the corresponding man pages for more detailed information.

- `makebdf` Creates bitmap distribution format files (`.bdf`) from F3 outline font files (`.f3b`)
- `bdf2pcf` Converts a font from `.bdf` format to portable compiled format (`.pcf`)

As illustrated in Table 4-4, many bitmap font file formats are architecture-dependent binary files. They cannot be shared between machines of different architectures (for example, between SPARC and x86).

Table 4-4 Bitmap Font Binaries

Font Format	Binary	Architecture-Specific
Bitmap distribution format	No	No
Portable compiled format	Yes	No
Little Endian prebuilt format	Yes	Yes (x86 and ppc)
Big Endian prebuilt format	Yes	Yes (SPARC)

The Solaris environment contains compressed `.pcf` files (files with `.pcf.z` extensions). You can uncompress these if you want. If you add fonts to your system, you can either compress the files or not. Use uncompressed files if you want the fonts to display somewhat faster. Leave the files compressed if you want to conserve disk space. For more information, see the `compress(1)` man page.

Replacing Outline Fonts With Bitmap Fonts

The Solaris environment automatically replaces some outline fonts with bitmap fonts when the size is appropriate. This improves performance, and in some cases improves the aesthetics and readability of the text. There may be several sizes at which replacement occurs for a given outline font.

Replacement Conditions

Currently in DPS, the `.pcf` bitmap format is substituted for F3 outline fonts, Type1 and TrueType fonts. Substitution occurs when there is no rotation, the requested pixel size is within one half of a pixel of the `.pcf` font size, and the `.pcf` font is a resource in a `.upr` (PostScript resource) file. The `.pcf` format can be substituted for all scalable versions of the fonts mentioned above.

Using TrueType and F3 Fonts in DPS

TrueType and F3 fonts behave exactly like Type1 fonts, except /FontType returns 42 for TrueType and 7 for F3 fonts. For example, the following PostScript code works the same regardless of the kind of font.

```
/Helvetica findfont 50 scalefont setfont
10 10 moveto (ABC) show
```

But the following code yields 42 for a TrueType font, 7 for an F3 font, and 1 for a Type1 font.

```
currentfont /FontType get ==
```

The kind of font returned depends on the current DPS internal resource path.

Locating Fonts

By default, the Solaris server looks for fonts in directories under the /usr/openwin/lib/X11/fonts directory. Table 4-5 shows the complete font directory structure. The directory names are preceded by /usr/openwin/lib/X11/fonts.

Table 4-5 Font Directory Structure

Directory	Subdirectory	File Suffixes	Contents
/TrueType		.ttf	TrueType fonts
/TrueType	/ttmap	.ttmap	TrueType character set specifications
/TTbitmaps		.pcf	Bitmap fonts
/100dpi		.pcf	Bitmap fonts
/75dpi		.pcf	Bitmap fonts
/F3	/afm	.f3b	F3 format outline fonts
	/map	.map	F3 character set specifications
/F3bitmaps		.pcf	Bitmap fonts

Table 4-5 Font Directory Structure (Continued)

Directory	Subdirectory	File Suffixes	Contents
/Speedo		.spd	Bitstream Speedo format outline fonts
/Type1		.pfa, .pfb	Type1 outline fonts
	/afm	.afm	Adobe font metrics
	/outline	.pfa, .pfb	Type1 outline fonts
	/prebuilt	.bepf, .lepf	Bitmaps for SPARC Solaris and x86
/Xt+		.pcf	Bitmap fonts
/Type3		.ps	PostScript outline fonts
/encodings		.enc	Encodings
/misc		.pcf	Bitmap fonts

Changing the Default Font Path in X11

In X11, the default font path is:

```
/usr/openwin/lib/X11/fonts/F3,
/usr/openwin/lib/X11/fonts/F3bitmaps,
/usr/openwin/lib/X11/fonts/Type1,
/usr/openwin/lib/X11/fonts/Speedo,
/usr/openwin/lib/X11/fonts/misc,
/usr/openwin/lib/X11/fonts/75dpi,
/usr/openwin/lib/X11/fonts/100dpi
```

Note that the directory paths *must* be absolute.

To change the default font path, use the Font Administrator GUI or command-line tools included with Solaris. For information about Font Administrator, see the *Font Administrator User's Guide*.

Installing and Managing Fonts

To install, delete, and view fonts for a workstation or NeWSprint printer, or to edit font paths or font attributes, use the Font Administrator GUI or command-line tools included with Solaris. For information about Font Administrator, see the *Font Administrator User's Guide*.

Using OPEN LOOK Fonts on X Terminals

The `/usr/openwin/share/src/fonts` directory contains OPEN LOOK fonts in bdf format. Follow the instructions from your vendor on how to install the fonts.

Server Overlay Windows

This chapter includes information on the following topics:

- Server overlays versus Solaris transparent overlays
- Suggestions for implementing overlays
- Description of server overlays

Server Overlays Versus Transparent Overlays

There are two different APIs that may be used to render transparent pixel values to an overlay window. The Transparent Overlay Extension is a Sun proprietary method to provide overlay capability in the X Window System. Transparent overlays can provide overlay functionality without hardware overlay support. Another well-known method known as server overlays can be used if your hardware supports it.

The Transparent Overlay Extension is a full X extension which requires extension calls to provide the transparency effect. The model is robust enough to emulate transparency on most systems, even if the hardware does not support real overlays. However, the operation of transparent windows is considerably slower when not supported in hardware.

Server Overlays is not an X extension, but instead the API provides a means for the X client to determine which visuals are overlays, and what pixel values to use for transparency. This API requires hardware support.

The Transparent Overlay Extension and server overlays may both be supported on the same screen, but they should never be used within the same window. Results are undefined. Trying to create a transparent overlay window in a visual specifically designed for server overlays may result in a `BadMatch`. Transparent overlays can avoid this by following the proper procedure to locating a partner overlay visual, as described in Chapter 6, “Transparent Overlay Windows.”

Tips for Programming Overlays

Parent-Child Model

It is strongly suggested that all transparency and overlays designs follow the simple underlay-parent overlay-child model. The desired underlay window is created first, and then the overlay is created as a child of the underlay. The overlay window is the only child of the underlay. This eliminates a number of odd cases for the X server, and also helps make sure there are no incidental interfering windows between the underlay and the overlay.

If using `Xlib` and/or programming your own `XCreateWindow` for these calls, it is important to understand that the client must provide extra information when creating a window that does not have the same visual as its parent. If the visual is not the default visual, you must provide a colormap or, if the colormaps are equivalent, assign the parent visual's colormap to the child. If the depths are different, you must provide a `BorderPixel` or `BorderPixmap`. Failure to do so may cause a `BadMatch` to return as the result of the create window.

For information about colormap equivalence, see the *X Server Device Developer's Guide*.

Stacking

When you raise a window, it does not matter if the window is an overlay window or not, it will raise to the top of the stack. If you lower a window, it does not matter if it is an overlay window, it will lower to the bottom of the stack.

This brings up the confusing notion of an overlay window being below an underlay window. This actually happens all the time. This is because the X server is enforcing the simple stacking policy, and it will do whatever is necessary to make that overlay window appear below the other windows, even if it has to software clip it.

Problems are best avoided by using the underlay-parent overlay-child model. That way, an underlay-overlay pair is treated as an entire application from the parent window, and it raises and lowers together.

Server Overlays

The Server Overlays API provides a simple way for applications to find overlay visuals and corresponding transparent pixel values. The overlay visual is used to create an overlay window, and the transparent pixel is a special pixel value the client may use to cause the underlays to show through. This pixel value is used in the standard way for foreground or background of any drawing operation, or the background of the overlay window.

The Server Overlays API specifies that the `SERVER_OVERLAY_VISUALS` property on the root window shall contain the following information. The size of the information returned by the server dictates how many instances of this structure are returned: one instance for every visual listed.

```
typedef struct {
    unsigned int visualid;
    unsigned int trans_type;
    unsigned int value;
    unsigned int layer;
} ServerOverlaysInfoRec;
```

<i>visualid</i>	The visual ID referenced by the X server. Usually returned to the client via <code>XGetVisualInfo</code> .
<i>trans_type</i>	The transparency type: 0 None, 1 Transparent Pixel, 2 Transparent Mask
<i>value</i>	The transparent pixel value or mask value
<i>layer</i>	The relative hardware layer of the visual with respect to transparent effects.

The *trans_type* value exists because there are provisions for other transparency types that are uncommon in the spec. The *trans_type* may be zero if a transparent pixel is not available, yet the X server wishes to advertise the visual as existing at a different set of plane groups than the usual windows, for the purpose of preventing exposes.

The layer is usually zero for normal windows, but the layer is really a relative number, with greater number representing plane groups above lower numbers. Negative numbers are possible.

Visuals not listed in the `SERVER_OVERLAY_VISUALS` property may be assumed to have a layer of zero and a transparency ability of none. These default values are only applicable to server overlay operations.

The transparent pixel shows through to the first window in the next layer. Layers do not affect stacking order in any way, but only apply to the transparency effect. It is strongly recommended to use overlays as a direct and only child of the designated underlay. This provides the best performance and the least confusion.

Server overlays support is device-dependent and may be a full hardware port or partial software emulation or a combination of software and hardware.

Server overlays are specified in “Programming X Overlay Windows” by Mark J. Kilguard, in the July/August 1993 issue of *The X Journal*.

Transparent Overlay Windows



This chapter presents information on the Transparent Overlay Extension application programming interface (API) that provides transparent overlay window capabilities in the Solaris OpenWindows environment. The chapter includes information on the following topics:

- How overlay windows differ from standard X windows
- How to create and draw to overlay windows
- How to ensure that applications using transparent overlay windows are portable to a wide range of devices

Note – It is recommended that you use server overlays if supported by your hardware. Server overlays are supported on FFB devices. For more information about server overlays, see Chapter 5, “Server Overlay Windows.”

What are Transparent Overlay Windows?

The transparent overlay extension allows the creation and manipulation of transparent overlay windows. These windows are X windows that allow the user to see through to the underlying window on a per-pixel basis. No special hardware is needed to create and use transparent overlay windows, as this functionality has been implemented in software. Complex transparent overlay manipulation on simple hardware may be time consuming; however, the X server can make use of special overlay hardware if available and the client

chooses the correct visuals. Note that, depending on your hardware and needs, you may have to adapt the client color allocations for transparent overlay windows.

Overlay windows allow applications to display temporary imagery in a display window. Users of an application that provides overlays can annotate an image with text or graphical figures, temporarily highlight certain portions of the imagery, or animate figures that appear to move against the background of the imagery. When geometry in the overlay is cleared, any underlying graphics do not need to be regenerated.

The transparent overlay extension allows the client to use standard X requests to draw primitives in *opaque paint*, which is a name for the standard way of drawing, or *transparent paint*, which makes affected pixels invisible. The paint type is associated with a standard X graphics context. Window backgrounds may also be set to transparent paint. Transparent overlay windows obey all regular window rules and operating procedures. For example, a transparent overlay window can be positioned anywhere in the window stacking order, regardless of what hardware the windows are associated with. This is implemented in software with the Solaris X server multiple plane group (MPG) functionality.

The server's multiple plane group capability allows windows from different parts of the hardware to coexist. Each window is associated with a visual, which in turn is associated with hardware. Although some hardware is physically created such that there is a definite "layering" (for example, windows created in a hardware overlay plane might be expected to always be seen above the regular windows), MPG works around this limitation in software. MPG allows the stacking order of the windows to be unaffected by the physical imitations of the hardware. As a result, stacking is simply the same as in the standard server. If overlay hardware is available and requested, MPG takes care of minimizing the work and increasing performance.

In general, an overlay is a pixel buffer (either physical or software simulated) into which graphics can be drawn. When the overlay is physical (that is, not simulated in software), erasing the overlay graphics does not damage the underlying graphics. This provides a performance advantage when the underlying graphics is complex and requires much time to repaint. When the overlay is in software, erasing the overlay graphics may generate an `EXPOSE` event.

Basic Characteristics of Transparent Overlay Windows

A transparent overlay window is a special class of an X `InputOutput` window into which pixels can be rendered transparently. Handles to transparent overlay windows have the X window type `Window`. Just like standard X windows, overlay windows are drawables, and an overlay window handle can be passed to any Xlib drawing routine that takes a `Drawable`.

Transparent overlay windows have extended the set of graphics context attributes to include an attribute for paint type. With the transparent overlay extension, transparent overlay windows can be rendered to with either opaque or transparent paint.

Paint Type

While standard X `InputOutput` windows and other drawables (such as `pixmap`s) accept only opaque paint, transparent overlay windows permit pixels to be rendered with *transparent paint*. Valid pixel values painted opaquely obscure pixels in underlying windows. Such pixels have associated color values that are displayed. Pixels rendered transparently have no intrinsic color; they derive their displayed color from the pixels that lie beneath.

Valid pixel values for pixels painted opaquely are obtained via `XAllocColor()` or another standard pixel allocation mechanism. Painting opaquely with a non-valid pixel value, for example a value that falls outside the valid `colormap` entries for a visual, produces undefined results for both transparent overlay windows and standard X `InputOutput` windows.

Paint type is defined with the data structure `XSolarisOvlPaintType`. By default, the paint type of a GC is opaque. The `XSolarisOvlPaintType` data structure is defined as:

```
typedef enum {
    XSolarisOvlPaintTransparent,
    XSolarisOvlPaintOpaque,
} XSolarisOvlPaintType;
```

Viewability

A transparent overlay window is considered viewable even if all its pixels are fully transparent. For viewable pixels in a transparent overlay window that are fully transparent, the underlying pixels in the underlay will be displayed.

If an overlay window is unmapped or moved, the underlay beneath may receive exposure events. This, for example, is the case on devices that cannot display the overlay window and underlay window in different plane groups.

Rendering Transparent Paint

Applications can render into overlay windows using Xlib primitives. In addition, applications can render transparent paint to transparent overlay windows through a Solaris Visual graphics library, such as the XGL graphics library, by specifying in the GC for that library that the paint is to be transparent. Each Solaris Visual library has a defined way of rendering into a transparent overlay window. See the library's documentation for information.

More on Transparent Overlay Characteristics

In most respects, a transparent overlay window is just like a standard X `InputOutput` window. Specifically, a transparent overlay window has these characteristics:

- It can be mapped or unmapped. The routines `XMapWindow`, `XUnmapWindow`, `XMapSubwindows`, and `XUnmapSubwindows` apply.
- An overlay window can possess its own cursor or use its parent's cursor. In other words, `XDefineCursor` and `XUndefineCursor` apply to overlay windows.
- An overlay window appears in the output of `XQueryTree`.
- The `event_mask` and `do_not_propagate_mask` window attributes function normally. An overlay window can express interest in any type of event.
- `XTranslateCoordinates` and `XQueryPointer` apply to overlay windows.
- `save_under` applies as for standard X windows.
- `override_redirect` applies as for standard X windows.

A transparent overlay window also has some characteristics that make it unique as a window. The following sections describe these characteristics.

Background

As defined in the X specification, windows can have a *background*. The main purpose of window background is to display something in the exposed areas of a window in case the client is slow to repaint these areas. This background is rendered whenever the window receives an `Expose` event. The background is rendered before the `Expose` event is sent to the client. The background is also rendered when the client makes an `XClearArea` or `XClearWindow` request.

Like standard X `InputOutput` windows, transparent overlay windows can also have a background. The background of a transparent overlay window is rendered just like a non-overlay window in response to `Expose` events, `XClearArea` requests, or `XClearWindow` requests. In addition to the standard types of background (`None`, `pixmap`, `pixel`, or `parent relative`), transparent overlay windows can also be assigned a new type of background: `transparent`. A new routine, `XSolarisOvlSetWindowTransparent`, is available to set the background type to `transparent`.

The background of a transparent overlay window is `transparent` by default. However, the application can still specify one of the usual X types of background: `None`, a `pixmap` `XID`, a `pixel` value, or `ParentRelative`, as shown in Table 6-1.

Table 6-1 Background Values for a Transparent Overlay Window

Background	Description
<code>transparent</code>	Background of transparent overlay window is <code>transparent</code> by default.
<code>None</code>	No rendering is performed when the overlay window encounters a condition that invokes background painting. Neither <code>transparent</code> nor <code>opaque</code> paint is rendered.
<code>Pixmap ID</code>	The background is rendered with <code>opaque</code> paint. The rendered pixel values are derived from the <code>pixmap</code> as defined in the X specification.

Table 6-1 Background Values for a Transparent Overlay Window

Background	Description
Single pixel value	The background is a solid color rendered with opaque paint.
ParentRelative	The behavior for a ParentRelative background depends on the parent window background and its type. If the parent window is an underlay, the background for the overlay window child will be rendered with opaque paint, and the rendered pixels will be as defined in the X specification. If the parent window is an overlay, the background of the overlay child will be the same as that of the parent, either transparent or opaque paint will be rendered.

Attempts to set the background of a non-overlay window with `XSolarisOvlSetTransparent` generates a `BadMatch` error. If an underlay window has a `ParentRelative` background and the parent window is an overlay with a transparent background, the underlay child is treated as if it has a background of `None`.

Window Border

The border of overlay windows is opaque. It is always drawn with opaque paint. Just like standard X `InputOutput` windows, the border width can be controlled with `XSetWindowBorderWidth`.

Backing Store

Backing store is disabled for overlay windows.

Window Gravity

The bit and window gravity attributes (`bit_gravity` and `win_gravity`) apply to transparent overlay windows. However, if the gravity calls for the movement of pixels, the transparency information is moved, along with the pixel color information.

Colormaps

Overlay colormap installation follows the X rules. If your application uses pixel-sharing overlay/underlay pairs, create a single colormap for both windows. Refer to “Choosing Visuals for Overlay/Underlay Windows” on page 62 and “Designing an Application for Portability” on page 80 for more on the subject of pixel-sharing pairs.

If the pair is known never to share hardware color LUTs, different colormaps can be safely assigned to the overlay and underlay window without the occurrence of colormap flashing.

Note – To improve the portability of applications and to minimize color flashing, use colormaps with the same colors in both the overlay and underlay window colormaps. If this is not possible, use one of the visual inquiry routines to determine whether different colormaps can be assigned without producing flashing.

Input Distribution Model

Overlay windows can express interest in events just like a standard X window. An overlay window receives any event that occurs within its visible shape; the paint type of the pixel at which the event occurs doesn't matter. For example, if the window expresses interest in window enter events, when the pointer enters the window's visible shape, the window receives a window enter event, regardless of whether the pixel is opaque or transparent.

This has some implications for how applications should implement interactive *picking* (selection) of graphical objects. Applications that draw graphical figures into an overlay window above other graphical figures drawn into the underlay window should express interest in events in either the overlay or underlay window, but not both. When the application receives an input event, it must use its knowledge of the overlay/underlay layering to determine which graphical figure has been picked.

For example, let's say the application expresses interest in events on the underlay window. When the application receives an event at coordinate (x, y), it should first determine if there is a graphical figure at that coordinate in the overlay. If so, the search is over. If not, the application should next see if there is a graphical figure at that coordinate in the underlay.

Print Capture

After graphical imagery has been rendered to an X window, the user may want the window contents to be captured and sent to a printer for hard copy output. The most widespread technique for doing this is to perform a *screen dump*, that is, to read back the window pixels with `XGetImage`, and to send the resulting image to the printer. To fit the image to the size of the printed page, some image resampling may be necessary. This can introduce *aliasing* artifacts into the image.

Another print capture technique that is growing in popularity in the X11 community is to re-render the graphics through a special printer graphics API. This API supports the standard Xlib graphics calls. It converts these calls into a page description language (PDL) format and sends it to the appropriate print spooler. The advantage of this technique is that the graphics can be scaled to fit the printed page by scaling the coordinates themselves rather than the pixels after scan conversion has been applied. As a result, aliasing artifacts are minimized.

The print API technique has a significant drawback when applied to an overlay/underlay window pair. Most PDLs only support the notion of opaque paint; they do not provide for the marking of transparent paint. In the PostScript PDL, for example, the marked pixels always supersede what was previously marked. Given such a limitation, it is not always possible to capture the imagery in an overlay/underlay window pair using this technique. Certainly, in applications where the background of the overlay is completely transparent and only opaque paint is drawn to it, the underlay could be marked first and the overlay marked second. But if transparent paint was drawn to the overlay, erasing other opaque paint in the overlay, this would not work.

Until this issue is resolved, capture overlay windows and send them to the printer using `XReadScreen` and resampling. Alternatively, do not use overlays to render information that is to be printed.

Choosing Visuals for Overlay/Underlay Windows

The Solaris transparent overlay API supports multiple plane group (MPG) and single plane group (SPG) devices. Display devices come in a wide variety of configurations. Some have multiple plane groups. Some have multiple hardware color lookup tables (LUTs). Some dedicate color LUTs to particular

plane groups and some share color LUTs between plane groups. This wide variety makes it difficult for an application writer to construct portable overlay applications.

For a given type of underlay window, some devices can provide some types of overlay windows with high-performance rendering. Other devices provide the same type of overlay window but with slower rendering. Some devices can support overlays with many colors, and some devices cannot. Some devices can support simultaneous display of both overlay and underlay colors for all types of overlays and underlays. Others support simultaneous display of colors but not for all overlay/underlay combinations. Still others support a certain degree of simultaneous color display. These devices support more than one hardware color LUT. Hardware might not contain enough color LUTs to enable all applications to display their colors simultaneously.

The following routines enable an application to negotiate with the system for a suitable overlay/underlay visual pair:

- `XSolarisOvlSelectPartner`
- `XSolarisOvlSelectPair`

These routines are described in the section “Designing an Application for Portability” on page 80.

The assumption is made that each application has an ideal configuration of windows and colors. An application should start out by asking for the “best” overlay/underlay pair. If this can be satisfied by the device, then the negotiation is complete, and the application proceeds to create windows on the selected underlay and overlay visuals. But if no visual pair satisfies the query, the application must relax its demands. To this end, it should specify the “next best” pair. The application may choose to ask for less colorful visuals, or it may accept lower rendering performance on one of the visuals. The process continues until either a satisfactory visual is found, or the application decides it’s not worth running in this environment without certain criteria being met.

The transparent overlay API provides routines that enable the application to conduct such a negotiation in a single subroutine call. The application specifies criteria to be matched for either the overlay visual, the underlay visual, or both. Application programmers are encouraged to use these routines to ensure portability to the widest range of graphics devices.

Example Program

The program below demonstrates a simple example of a transparent overlay. The program creates a transparent overlay window, draws the window border in white, displays a text string in white, and draws a white filled rectangle. The paint type is opaque by default, and the window background is transparent by default. Use the following Makefile to compile and link the program.

```
simple: simple.c
    cc -I../ -I/usr/openwin/include -o simple simple.c \
        -L/usr/openwin/lib -lX11 -lXext
```

Code Example 6-1 Transparent Overlay Example Program

```
#include <stdio.h>
#include <X11/Xlib.h>
#include "X11/Xmd.h"
#include <X11/extensions/transovl.h>
#include <X11/extensions/transovlstr.h>

Display          *display;
Window           window;
XSetWindowAttributes attribs;
GC               gc;
XGCValues        gcvalues;

main()
{
    display = XOpenDisplay("");
    attribs.override_redirect = True;
    attribs.border_pixel = WhitePixel(display, 0);
    window = XSolarisOvlCreateWindow(display,
                                     DefaultRootWindow(display),
                                     100, 100, 500, 500, 10,
                                     CopyFromParent, InputOutput, CopyFromParent,
                                     CWBorderPixel | CWOverrideRedirect, &attribs);
    gcvalues.font = XLoadFont(display, "fixed");
    gcvalues.foreground = WhitePixel(display, 0);
    gc = XCreateGC(display, window, GCFont | GCForeground, &gcvalues);
    XMapWindow(display, window);
    XDrawString(display, window, gc, 50, 50, "This is a test", 14);
    XFillRectangle(display, window, gc, 70, 70, 100, 100);
}
```

```

XFlush(display);
while (1);
}

```

Overview of the Solaris Transparent Overlay Window API

The transparent overlay window API includes the routines listed in Table 6-2. These routines are provided by `libXext.so`. To use the Solaris overlay routines, do the following:

- Include the file `/usr/openwin/include/X11/extensions/transovl.h`
- Link the library device handler with the library `/usr/openwin/lib/libXext.so`

Table 6-2 List of Transparent Overlay Window Routines

Name	Description
<code>XSolarisOvlCreateWindow</code>	Creates an overlay window.
<code>XSolarisOvlIsOverlayWindow</code>	Indicates whether a window is an overlay window.
<code>XSolarisOvlSetPaintType</code>	Specifies the type of paint rendered by subsequent Xlib drawing.
<code>XSolarisOvlGetPaintType</code>	Gets the current paint type.
<code>XSolarisOvlSetWindowTransparent</code>	Sets the background state of an overlay window to be transparent.
<code>XSolarisOvlCopyPaintType</code>	Renders opaque and transparent paint into the destination drawable based on the paint type attributes of the pixels in the source drawable.
<code>XSolarisOvlCopyAreaAndPaintType</code>	Copies the area and paint type from one pair of drawables to another.
<code>XReadScreen</code>	Returns the displayed colors in a rectangle of the screen.

Table 6-2 List of Transparent Overlay Window Routines

Name	Description
XSolarisOvlSelectPartner	Returns the optimal overlay or underlay visual for an existing visual.
XSolarisOvlSelectPair	Selects an optimal overlay/underlay pair that best meets a set of defined criteria for the overlay and underlay visuals.

The remainder of this chapter discusses the transparent overlay API routines.

Creating Transparent Overlay Windows

You can create a transparent overlay using `XSolarisOvlCreateWindow`. This routine behaves exactly as `XCreateWindow` except that the resulting window is a transparent overlay window. The newly created window can be rendered into with both opaque and transparent paint, and the background of the overlay window is transparent.

The class argument to `XSolarisOvlCreateWindow` should be `InputOutput`. An overlay window can be created as an `InputOnly` window but, in this case, it will behave like a standard `InputOnly` window. It is only for `InputOutput` windows that there is a difference between overlay and non-overlay.

The syntax and arguments for `XSolarisOvlCreateWindow` are shown below.

```
Window
XSolarisOvlCreateWindow(Display *display, Window parent, int x, int y,
    unsigned int width, unsigned int height,
    unsigned int border_width, int depth, unsigned int class,
    Visual * visual, unsigned long valuemask,
    XSetWindowAttributes * attr)
```

The arguments for this routine are the same as those for `XCreateWindow`.

- `display` Specifies the connection to the X server.
- `parent` Specifies the parent window.

<code>x, y</code>	Specifies the coordinates of the upper-left pixel of this window, relative to the parent window.
<code>width, height</code>	Specifies the width and height, in pixels, of the window.
<code>border_width</code>	Specifies the width, in pixels, of the window's borders.
<code>depth</code>	Specifies the depth of the window.
<code>class</code>	Specifies the class of the window. If the class is not <code>InputOutput</code> , the window will not be an overlay window.
<code>visual</code>	Specifies a pointer to the visual structure for this window.
<code>valuemask</code>	Specifies which window attributes are defined in the <code>attr</code> argument.
<code>attr</code>	Specifies the attributes of the window.

You can use any visual to create the overlay. However, not all overlay/underlay visual pairs may be optimal. Each screen defines a set of optimal overlay/underlay visual pairs. These define the optimal visuals of the overlay windows that can be created with a particular underlay visual. Likewise, they define the optimal visuals of underlay windows that can be created with a particular overlay visual. You can determine the optimal pairs using `XSolarisOvlSelectPair` and `XSolarisOvlSelectPartner`.

The definition of *optimal* varies from device to device, but it will usually refer to the ability of a device to create an overlay window in a different plane group than that of an underlay window. See page 86 for more information on overlay/underlay visual pairs.

Overlay windows are destroyed with the Xlib routines `XDestroyWindow` or `XDestroySubwindows`.

Setting the Paint Type of a Graphics Context

You can set a GC's paint type with the `XSolarisOvlSetPaintType` routine. `XSolarisOvlSetPaintType` specifies the type of paint rendered by subsequent Xlib drawing with the given GC. It controls whether Xlib drawing

routines using this GC produce opaque or transparent pixels on overlay windows. The paint type specified applies to the GC until it is changed by another call to this routine. The paint type attribute applies to both the foreground and background GC attributes. The syntax and arguments are shown below.

```
void
XSolarisOvlSetPaintType (Display *display, GC gc,
                        XSolarisOvlPaintType paintType)
```

<code>display</code>	Specifies the connection to the X server.
<code>gc</code>	Specifies the affected GC.
<code>paintType</code>	Specifies the type of paint rendered by subsequent Xlib drawing routines using the specified GC.

The value of `paintType` can be `XSolarisOvlPaintOpaque` or `XSolarisOvlPaintTransparent`.

- If the value of `paintType` is `XSolarisOvlPaintOpaque`, the pixels generated by subsequent Xlib drawing routines with this GC will be opaque. This means the pixels will obscure underlying pixels. This is the default.
- If the value of `paintType` is `XSolarisOvlPaintTransparent`, the pixels generated by subsequent Xlib drawing routines with this GC will be transparent. This means that, for these pixels, the color of the underlying pixels is displayed.

Setting the Background State of a Transparent Overlay Window

You can set the background state of a transparent overlay window to be transparent with the `XSolarisOvlSetWindowTransparent` routine. Any background rendering that occurs after this request causes the background to be transparent. To change background state to any other value, use `XChangeWindowAttributes()`, `XSetWindowBackground()`, or `XSetWindowBackgroundPixmap()`.

The syntax and arguments of `XSolarisOvlSetWindowTransparent` are shown below.

```
void  
XSolarisOvlSetWindowTransparent (Display *display, Window w)
```

<code>display</code>	Specifies the connection to the X server.
<code>w</code>	The transparent overlay window.

Note – If `w` is not a transparent overlay window, a `BadMatch` error results.

Rendering to a Transparent Overlay Window

Once a transparent overlay window is created, you can use all the standard Xlib primitive rendering routines, such as `XDrawLines` and `XFillRectangles`, to draw into the window. When drawing to transparent overlay windows, the paint type attribute of the GC is used to control the quality of the pixels rendered. The paint type attribute applies to both the foreground and background GC attributes. To set the paint type, use the `XSolarisOvlSetPaintType` routine; for information on this routine, see page 67.

The paint type of the GC also controls the type of pixels rendered with `XPutImage`. If the paint type of the argument GC is `XSolarisOvlPaintOpaque`, the color information from the source image is used and the pixels are rendered with opaque paint. However, if the paint type is `XSolarisOvlPaintTransparent`, the source color information is ignored, and the pixels are rendered with transparent paint.

If a GC with a paint type of `XSolarisOvlPaintTransparent` is used to render to a drawable other than a transparent overlay window, such as an underlay window or pixmap, the GC paint type is ignored, and the pixels are rendered with opaque paint.

Querying the Characteristics of a Transparent Overlay Window

You can determine whether a window is an overlay window using the routine `XSolarisOvlIsOverlayWindow`. You can also determine a GC's current paint type using the routine `XSolarisOvlGetPaintType`.

Determining Whether a Window is an Overlay Window

You can use the routine `XSolarisOvlIsOverlayWindow` to determine whether a window is an overlay window. The routine returns `True` if the given window `w` is a transparent overlay and returns `False` otherwise.

```
Bool XSolarisOvlIsOverlayWindow (Display *display, Window w)
```

<code>display</code>	Specifies the connection to the X server.
<code>w</code>	Specifies the window.

Determining the Paint Type of a Graphics Context

The routine `XSolarisOvlGetPaintType` returns the GC's current paint type.

```
XSolarisOvlPaintType  
XSolarisOvlGetPaintType (Display *display, GC gc)
```

<code>display</code>	Specifies the connection to the X server.
<code>gc</code>	The GC to be inquired about.

Pixel Transfer Routines

The transparent overlay API provides three pixel transfer routines:

- `XSolarisOvlCopyPaintType` – Renders opaque and transparent point into a destination drawable based on the paint type attributes of the source drawable.

- `XSolarisCopyAreaAndPaintType` – Copies an area and its paint type from one pair of drawables to another.
- `XReadScreen` – Returns the colors displayed in a given area of the screen.

The existing Xlib pixel transfer routines `XGetImage`, `XCopyArea`, and `XCopyPlane` can also be used with overlay windows. The use of these routines is described below.

Filling an Area Using the Source Area Paint Type

The `XSolarisOvlCopyPaintType` routine uses the paint type information of a specified rectangle in a source rectangle to control a fill operation in a specified rectangle in a destination rectangle. The source rectangle and destination rectangle can be any type of drawable. If the source rectangle is a transparent overlay, the paint type attribute of its pixels is used as the source of the copy, and the color information is ignored. If the source rectangle is any other type of drawable, the bit plane specified in the routine is treated as if it were paint type data and it is used for the copy. In this case, the bit plane must have only one bit set.

The syntax and arguments are shown below.

```
void
XSolarisOvlCopyPaintType(Display *display, Drawable src,
    Drawable dst, GC gc, int src_x, int src_y,
    unsigned int width, unsigned int height, int dest_x,
    int dest_y, unsigned long action, unsigned long plane)
```

<code>display</code>	Specifies the connection to the X server.
<code>src</code>	Specifies the source drawable from which to obtain the paint type information.
<code>dst</code>	Specifies the destination drawable.
<code>gc</code>	Specifies the GC.
<code>src_x, src_y</code>	Specify the x and y coordinates of the upper-left corner of the source rectangle relative to the origin of the source drawable.

width, height	Specify the width and height of both the source and destination rectangles.
dest_x, dest_y	Specify the x and y coordinates of the upper-left corner of the destination rectangle relative to the origin of the destination drawable.
action	Specifies which paint type data is to be copied. This can be one of <code>XSolarisOvlCopyOpaque</code> , <code>XSolarisOvlCopyTransparent</code> , or <code>XSolarisOvlCopyAll</code> .
plane	Specifies the bit-plane of the <code>src</code> drawable to be used as paint type information when the source is not a transparent overlay.

`src` and `dst` must have the same screen, or a `BadMatch` error results.

Table 6-3 summarizes the possible combinations of `src` and `dst` and their actions. The left side of the table shows the possible `src` combinations. The top of the table shows the possible `dst` combinations. The actions A1-A4 are explained following the table.

Table 6-3 XSolarisOvlCopyPaintType Source/Destination Combinations and Actions

Source/Destination	Overlay	Drawable
overlay	A1	A2
drawable	A3	A4

- A1—Opaque pixels in the source overlay cause the corresponding pixels in the destination to be filled with opaque color as specified by the fill attributes of the GC. Transparent pixels in the source cause the corresponding pixels in the destination to be filled with transparent paint.
- A2—Opaque pixels in the source overlay cause the corresponding pixels in the destination to be filled according to the fill attributes of the GC. Transparent pixels in the source overlay cause the corresponding pixels in the destination to be filled according to the same fill attributes of the GC, but with the foreground and background pixels swapped.
- A3—The pixels in the destination overlay are filled with opaque paint or made transparent as in A1 above depending on the bit values of the source drawable's `plane`. Bit values of 1 in the source are treated as if they were opaque pixels and bit values of 0 are treated as if they were transparent.

- A4—The pixels in the destination drawable are filled with paint as in A2 above depending on the bit values of the source drawable's plane. Bit values of 1 in the source bit plane are treated as if they were opaque pixels and bit values of 0 are treated as if they were transparent.

The `action` argument specifies whether opaque paint (`XSolarisOvlCopyOpaque`), transparent paint (`XSolarisOvlCopyTransparent`), or both (`XSolarisOvlCopyAll`) should be operated upon. This allows a client to *accumulate* opaque or transparent paint.

If portions of the source rectangle are obscured or are outside the boundaries of the source drawable, the server generates `Expose` events, using the same semantics as `XCopyArea`.

This routine uses these GC components: function, plane-mask, fill-style, subwindow-mode, graphics-exposures, clip-x-origin, clip-y-origin, and clip-mask. It might use these GC mode-dependent components: foreground, background, tile, stipple, tile-stipple-x-origin, tile-stipple-y-origin.

`XSolarisOvlCopyPaintType` can generate `BadDrawable`, `BadGC`, `BadMatch`, and `BadValue` errors.

Copying an Area and Its Paint Type

The `XSolarisCopyAreaAndPaintType` routine copies the specified area of source drawable for the color information to the specified area of destination drawable for color information. If the destination drawable is not an overlay, it also fills the specified areas of paint type information destination drawable according to the paint type information specified in the paint type information source drawable.

You can use `XSolarisOvlCopyAreaAndPaintType` to combine an image in the client's memory space (consisting of color and/or paint type information) with a rectangle of the specified overlay window. To do this, first move the image and paint type data into the server: use `XPutImage` to copy the data into two pixmaps of the appropriate depths. Then call `XSolarisOvlCopyAreaAndPaintType` with the color and paint type drawables to copy information to the overlay.

You can also use `XSolarisOvlCopyAreaAndPaintType` to retrieve pixel information (color and/or paint type information) from a specified drawable. To do this, call `XSolarisOvlCopyAreaAndPaintType` with two separable destination drawables. To get the data from the server into the client's memory space, call `XGetImage` on each of the drawables.

The syntax and arguments for `XSolarisCopyAreaAndPaintType` are shown below.

```
void
XSolarisOvlCopyAreaAndPaintType(Display * display, Drawable
colorsrc,
    Drawable painttypesrc, Drawable colordst,
    Drawable painttypedst, GC colorgc, GC painttypegc,
    int colorsrc_x, int colorsrc_y, int painttypesrc_x,
    int painttypesrc_y, unsigned int width, unsigned int height,
    int colordst_x, int colordst_y, int painttypedst_x,
    int painttypedst_y, unsigned long action, unsigned long plane)
```

<code>display</code>	Specifies the connection to the X server.
<code>colorsrc</code>	The color information source drawable. <code>colorsrc</code> can be any depth drawable or an overlay window.
<code>painttypesrc</code>	The paint type information source drawable. <code>painttypesrc</code> can be any drawable or an overlay window. If <code>painttypesrc</code> is not an overlay window, the bit plane of <code>painttypesrc</code> specified in <code>plane</code> is treated as if it were paint type data and it is used for the copy. <code>plane</code> must have only one bit set in this case.
<code>colordst</code>	The color information destination drawable.
<code>painttypedst</code>	The paint type information destination drawable. If <code>colordst</code> is an overlay, this drawable will be ignored.
<code>colorgc</code>	The GC to use for the color information copy.
<code>painttypegc</code>	The GC to use to fill areas in <code>painttypedst</code> . If <code>colordst/painttypedst</code> is an overlay, this GC will be ignored.

<code>colorsrc_x</code> <code>colorsrc_y</code>	The X and Y coordinates of the upper-left corner of the source rectangle for color information relative to the origin of the color source drawable.
<code>painttypesrc_x</code> <code>painttypesrc_y</code>	The X and Y coordinates of the upper-left corner of the source rectangle for paint type information relative to the origin of the paint type source drawable.
<code>width</code> , <code>height</code>	The dimensions in pixels of all the source and destination rectangles.
<code>colordst_x</code> <code>colordst_y</code>	The X and Y coordinates of the upper-left corner of the destination rectangle for color information relative to the origin of the color destination drawable.
<code>painttypedst_x</code> <code>painttypedst_y</code>	The X and Y coordinates of the upper-left corner of the destination rectangle for paint type information relative to the origin of the paint type destination drawable. If <code>colordst/painttypedst</code> is an overlay, <code>colordst_x</code> and <code>colordst_y</code> will be used.
<code>action</code>	Specifies which paint type data is to be copied. This can be one of <code>XSolarisOvlCopyOpaque</code> , <code>XSolarisOvlCopyTransparent</code> , or <code>XSolarisOvlCopyAll</code> .
<code>plane</code>	Specifies the source bit-plane in <code>painttypesrc</code> to be used as paint type information when <code>painttypesrc</code> is not an overlay.

`colordst` can be any drawable, but must be of the same depth and have the same root as `colorsrc`, otherwise, a `BadMatch` error results. If `colordst` is an overlay, then `painttypedst` is ignored, otherwise `painttypedst` can be any type of drawable.

Table 6-4 summarizes the possible combinations of sources and destinations and their respective actions. The left side of the table shows the possible `colorsrc/painttypesrc` combinations and the top of the table shows the possible `colordst/painttypedst` combinations. The actions A1-A8 are

explained below the table. An Impossible entry in the table indicates that the given combination is impossible, since the `painttypedst` is ignored when the `colordst` is an overlay.

Table 6-4 XSolarisOvlCopyAreaAndPaintType Source/Destination Combinations and Actions

	Overlay/Overlay	Overlay/Drawable	Drawable/Overlay	Drawable/Drawable
overlay/overlay	A1	Impossible	A5	A5
overlay/drawable	A2	Impossible	A6	A6
drawable/overlay	A3	Impossible	A7	A7
drawable/drawable	A4	Impossible	A8	A8

- A1—The paint type information from `painttypesrc` is used as a mask to copy the color information from `colorsrc` to `colordst`. Opaque pixels in `painttypesrc` cause the corresponding pixel in `colorsrc` to be copied to `colordst`, transparent pixels cause the corresponding pixel in `colordst` to be made transparent. If a transparent pixel from `colorsrc` is copied to `colordst`, the actual color transferred will be undefined.
- A2—Same as A1 except that the paint type information is extracted from the bit-plane of `painttypesrc` specified by `plane`. A bit value of 1 indicates an opaque pixel whereas a bit value of 0 indicates transparent.
- A3—Same as A1 except that a non-overlay drawable is used to obtain the color information so there will be no undefined colors due to transparent pixels.
- A4—Same as A3 except that the paint type information is taken from the specified bit-plane of `painttypesrc` as in A2.
- A5—The paint type information from `painttypesrc` is used as a mask to copy the color information from `colorsrc` to `colordst` as in A1. In addition, the paint type information controls rendering to the `painttypedst` drawable as in `XSolarisOvlCopyPaintType`.
- A6—Same as A5 except that the paint type information is taken from the specified bit-plane of `painttypesrc` as in A2.
- A7—Same as A5 except that there will be no undefined colors due to transparent color source pixels.
- A8—Same as A7 except that the paint type information is taken from the specified bit-plane of `painttypesrc` as in A2.

The `action` argument specifies whether opaque paint (`XSolarisOvlCopyOpaque`), transparent paint (`XSolarisOvlCopyTransparent`), or both (`XSolarisOvlCopyAll`) should be copied. This allows a client to accumulate opaque or transparent paint.

`NoExpose` and `GraphicsExpose` events are generated in the same manner as `XSolarisOvlCopyPaintType`.

If an overlay is used for the `colordst` argument, the `painttypedst`, `painttypegc`, `painttypedst_x` and `painttypedst_y` arguments will all be ignored. A `NULL` pointer can be used for `painttypegc` and a value of `None` can be used for `painttypedst`. The overlay will have the exact paint type defined by the pixels in the area specified in `painttypesrc`. The color information copy will not affect the destination paint type.

This function uses these GC components from `colorgc`: function, plane-mask, subwindow-mode, graphics-exposures, clip-x-origin, clip-y-origin, and clip-mask.

If `colordst` is not an overlay then this function will use these GC components from `painttypegc`: function, plane-mask, fill-style, subwindow-mode, clip-x-origin, clip-y-origin, and clip-mask. In addition, it may also use these GC mode-dependent components: foreground, background, tile, stipple, tile-stipple-x-origin, and tile-stipple-y-origin.

`XSolarisOvlCopyAreaAndPaintType` can generate `BadDrawable`, `BadGC`, `BadMatch`, and `BadValue` errors.

Retrieving Overlay Color Information

The routine `XReadScreen` returns the displayed colors in a rectangle of the screen. It thus provides access to the colors displayed on the screen of the given window.

On some types of advanced display devices, the displayed colors can be a composite of the data contained in several different frame stores, and these frame stores can be of different depth and visual types. In addition, there can be overlay/underlay window pairs in which part of the underlay is visible beneath the overlay. Because the data returned by `XGetImage` is undefined for portions of the rectangle that have different depths, `XGetImage` is inadequate to return the picture the user is actually seeing on the screen. In addition,

`XGetImage` cannot composite pixel information for an overlay/underlay window pair because the pixel information lies in different drawables. `XReadScreen` addresses these problems.

Rather than returning pixel information, `XReadScreen` returns color information—the actual displayed colors visible on the screen. The routine returns the color information from any window within the boundaries of the specified rectangle. Unlike `XGetImage`, the returned contents of visible regions of inferior or overlapping windows of a different depth than the specified window's depth are not undefined. Instead, the actual displayed colors for these windows is returned.

Note – The colors returned are the ones that would be displayed if an unlimited number of hardware color LUTs were available on the screen. Thus, the colors returned are the theoretical display colors. If colormap flashing is present on the screen because there aren't enough hardware color LUTs to display all of the software colormaps simultaneously, the returned colors may be different from the colors that are actually displayed.

The syntax and arguments for this routine are shown below.

```
XImage *
XReadScreen (Display *display, Window w, int x, int y,
             unsigned int width, unsigned int height,
             Bool includeCursor)
```

<code>display</code>	Specifies the connection to the X server.
<code>w</code>	Specifies the window from whose screen the data is read.
<code>x, y</code>	Specify the X and Y coordinates of the upper-left corner of the rectangle relative to the origin of the window <code>w</code> .
<code>width, height</code>	Specify the width and height of the rectangle.
<code>includeCursor</code>	Specifies whether the cursor image is to be included in the colors returned.

If `w` is an overlay window, the overlay color information is returned wherever there is opaque paint in the specified rectangle. The color information of the underlay is returned wherever there is transparent paint in the overlay. In general, since this underlay can be an overlay window containing transparent paint, the color information for a coordinate (x, y) that contains transparent paint is the youngest non-inferior that has opaque paint at (x, y) .

The color data is returned as an `XImage` structure. The returned image has the same width and height as the arguments specified. The format of the image is `ZPixmap`. The depth of the image is 24 and the `bits_per_pixel` is 32. The most significant 8 bits of color information for each color channel (red, green, blue) are returned in the bit positions defined by `red_mask`, `green_mask`, and `blue_mask` in the `XImage`. The values of the following attributes of the `XImage` are server dependent: `byte_order`, `bitmap_unit`, `bitmap_bit_order`, `bitmap_pad`, `bytes_per_line`, `red_mask`, `green_mask`, `blue_mask`.

If `includeCursor` is `True`, the cursor image is included in the returned colors. Otherwise, it is excluded.

Note that the borders of the argument window (and other windows) can be included and read with this request.

If a problem occurs, `XReadScreen` returns `NULL`.

Using Existing Xlib Pixel Transfer Routines

The Xlib pixel transfer routines `XGetImage`, `XCopyArea`, and `XCopyPlane` can also be used with transparent overlay windows.

XGetImage

On non-overlay drawables, the `XGetImage` routine works as defined in the X11 specification. The same is true for overlay windows, with the exception that, on these windows, the color information returned for transparent pixels is undefined. Clients who simply want to retrieve the display colors for a region on the screen should use `XReadScreen`.

XCopArea and XCopPlane

When both the source and destination drawables are non-overlay, the `XCopArea` and `XCopPlane` routines work as defined in the X11 specification. However, note the following for the cases in which either the source or the destination drawable is an overlay window.

- When the source drawable is overlay and the destination drawable is non-overlay, only the color information is copied; the paint type information in the source is ignored. Color information for transparent pixels is undefined.
- When the source drawable is non-overlay and the destination drawable is overlay, the copy is performed as the paint type in the GC indicates. If the paint type is `XSolarisOvlPaintOpaque`, the color information is copied into the destination with opaque paint. If the paint type is `XSolarisOvlPaintTransparent`, the color information is ignored, and the destination pixels are transparent.
- When both the source drawable and destination drawable are overlay, the paint type of the source is ignored, and this behaves as if the source were not an overlay. If copying both color and paint type information is the desired result, use `XSolarisOvlCopyAreaAndPaintType`.

Designing an Application for Portability

The Solaris overlay API provides two routines that help ensure application portability across devices. These routines are:

- `XSolarisOvlSelectPartner` - Enables the application to select the visual that is the best partner for an existing overlay or underlay visual.
- `XSolarisOvlSelectPair` - Enables the application to select the optimal overlay and underlay visual pair from the set of all visual pairs for the screen.

These routines are described below.

Selecting a Visual for an Overlay/Underlay Window

Portable applications using overlays can search for an appropriate overlay visual to use for a given underlay visual, or vice versa. Each X screen supporting the overlay extension defines a set of overlay visuals whose windows are best for use as children of underlay windows. For each underlay visual, there is a set of optimal overlay visuals. Together, all combinations of underlay visuals and their optimal overlay visuals form the set of optimal overlay/underlay pairs for that screen. The overlay and underlay visuals of an optimal pair are partners of each other.

The routine `XSolarisOvlSelectPartner` allows the client to select, given an underlay visual, an optimal overlay that meets certain criteria. Inversely, it also allows the client to select an optimal underlay visual given an overlay visual. The client is assured that, short of X errors not related to overlays, it can successfully create a window with the returned visual.

This routine searches through the optimal partners of the given visual, applying the criteria specified. It returns a success or failure status depending on whether it finds a visual that meets the criteria. A criterion can be one of two types:

1. Hard criterion – A criterion that must be satisfied. Only visuals that meet hard criteria are candidates for successful matches.
2. Soft criterion – A desirable criterion, but one that is not required.

The visual that matches all hard criteria and the most soft criteria is chosen, and its attributes are returned. If two or more visuals are found that meet all of the hard criteria and the same number of soft criteria, one of them will be chosen and returned. It is implementation dependent which one is chosen.

The syntax and arguments for `XSolarisOvlSelectPartner` are shown below.

```
XSolarisOvlSelectStatus
XSolarisOvlSelectPartner (Display *display, int screen,
    VisualID vid, XSolarisOvlSelectType seltype, int numCriteria,
    XSolarisOvlVisualCriteria *pCriteria,
    XVisualInfo *visinfoReturn,
    unsigned long *unmetCriteriaReturn)
```

display	Specifies the connection to the X server.
screen	An integer specifying the screen for the visual vid.
vid	The XID of the visual to find a partner for.
seltype	The type of selection that is to be done.
numCriteria	The number of XSolarisOvlVisualCriteria structures in the pCriteria array.
pCriteria	An array of criteria structures in priority order from high to low specifying the criteria to be used in selecting the visual.
visinfoReturn	A pointer to a caller provided XVisualInfo structure. On successful return, this structure contains a description of the chosen visual.
unmetCriteriaReturn	A pointer to a bitmask that describes the criteria that were not satisfied. This return argument is meaningful only when the routine returns a value of XSolarisOvlQualifiedSuccess, or XSolarisOvlCriteriaFailure.

Argument Types

XSolarisOvlSelectType is an enumeration defining two types of selections that can be done in XSolarisOvlSelectPartner. It is defined as:

```
typedef enum {
    XSolarisOvlSelectBestOverlay,
    XSolarisOvlSelectBestUnderlay,
} XSolarisOvlSelectType;
```

`XSolarisOvlVisualCriteria` is a structure defining various criteria to be used during visual selection, along with indications of the stringency of the criteria. This structure is defined as:

```
typedef struct {
    unsigned long    hardCriteriaMask;
    unsigned long    softCriteriaMask;
    int              c_class;
    unsigned int     depth;
    unsigned int     minColors;
    unsigned int     minRed;
    unsigned int     minGreen;
    unsigned int     minBlue;
    unsigned int     minBitsPerRGB;
    unsigned int     minBuffers;
} XSolarisOvlVisualCriteria;
```

`hardCriteriaMask` and `softCriteriaMask` are bitmasks whose values can be the logical OR of any of the following bitmasks:

```
#define XSolarisOvlVisualClass      (1L<<0)
#define XSolarisOvlDepth           (1L<<1)
#define XSolarisOvlMinColors       (1L<<2)
#define XSolarisOvlMinRed          (1L<<3)
#define XSolarisOvlMinGreen        (1L<<4)
#define XSolarisOvlMinBlue         (1L<<5)
#define XSolarisOvlMinBitsPerRGB   (1L<<6)
#define XSolarisOvlMinBuffers      (1L<<7)
#define XSolarisOvlUnsharedPixels  (1L<<8)
#define XSolarisOvlUnsharedColors  (1L<<9)
#define XSolarisOvlPreferredPartner (1L<<10)
```

Return Types

`XSolarisOvlSelectStatus` is a value that indicates whether the routine succeeded in finding a visual and, if it failed, the reason for the failure. The return value can be one of:

```
typedef enum {
    XSolarisOvlSuccess,
    XSolarisOvlQualifiedSuccess,
    XSolarisOvlCriteriaFailure,
    XSolarisOvlFailure,
} XSolarisOvlSelectStatus;
```

- `XSolarisOvlSuccess` is returned if the search is completely successful in finding a visual that meets all hard and soft criteria of one of the `XSolarisOvlVisualCriteria` structure.
- `XSolarisOvlQualifiedSuccess` is returned if the chosen visual satisfies all hard criteria of one of the `XSolarisOvlVisualCriteria` structure, but doesn't meet all soft criteria. In this case, `unmetCriteriaReturn` contains the logical OR of the soft criteria that were not met.
- `XSolarisOvlCriteriaFailure` indicates that no visual could be found that meets all the hard criteria of any of the `XSolarisOvlVisualCriteria` structures. In this case, `unmetCriteriaReturn` contains the logical OR of the hard criteria that were not met for the `XSolarisOvlVisualCriteria` structure with the fewest hard criteria not met.
- `XSolarisOvlFailure` is returned if some other error is encountered besides criteria match failure.

Multiple Criteria Sets

`XSolarisOvlSelectPartner` supports a *degradation sequence* of criteria sets. This means that multiple criteria sets can be specified in a single call. First, the routine attempts to find a visual matching the first criteria set. If a visual is found that meets all of the hard criteria of the first set, this visual is chosen. If no visual meets all hard criteria of the first set, the routine performs a search using the second criteria set. This process continues until either a visual is found that meets the hard criteria of some criteria set, or all sets have been

used to search. This degradation sequence allows clients to specify the criteria for the most preferred visual as the first criteria set. Visuals that are acceptable but are less desirable can be specified in criteria sets following the first criteria set. This allows the search to proceed through a progressive relaxation in the client's requirements for the visual with a single subroutine call.

Any of the possible criteria can be specified either as a hard or soft criteria for a particular criteria set. For a given set, `hardCriteriaMask` is the logical OR of the criteria bitmasks that are to be applied as hard criteria during the search. Likewise, `softCriteriaMask` is the logical OR of the soft criteria bitmasks.

Some criteria have values associated with them. These values are provided by other data members in the `XSolarisOvlVisualCriteria` structure. In the criteria descriptions that follow, these data members are mentioned where applicable.

- `XSolarisOvlVisualClass` specifies that the client wants the selected visual to have a specific visual class. The required class is specified in `c_class`.
- The following criteria interact within one another: `XSolarisOvlDepth`, `XSolarisOvlMinColors`, `XSolarisOvlMinRed`, `XSolarisOvlMinGreen`, and `XSolarisOvlMinBlue`. Typically only some subset of these should be specified.
- `XSolarisOvlDepth` specifies that the depth of the selected visual is to be equal to `depth`.
- `XSolarisOvlMinColors` specifies that the selected visual is to have at least `minColors` number of total displayable colors.
- `XSolarisOvlMinRed`, `XSolarisOvlMinGreen`, and `XSolarisOvlMinBlue` can be used to indicate more specific color requirements for `DirectColor` or `TrueColor` visuals. Their corresponding values are specified in `minRed`, `minGreen`, and `minBlue`, respectively. These indicate that the selected visual must have at least the specified number of reds, greens, and/or blues.
- `XSolarisOvlMinBitsPerRGB` specifies that the selected visual is to have at least `minBitsPerRGB` of color channel output from colormaps created on that visual.
- `XSolarisOvlMinBuffers` specifies that the client wants the selected visual to be able to be assigned at least `minBuffers` number of accelerated MBX image buffers.

- `XSolarisOvlUnsharedPixels` selects partner visuals whose window pixels don't lie in the same drawing plane groups as the window pixels of the argument visual `vid`. If a visual uses the same drawing plane group as the argument visual, it is not matched by this criterion.
- `XSolarisOvlUnsharedColors` selects partner visuals whose window pixel colors can be displayed simultaneously when the overlay/underlay window pair has the colormap focus. If a visual shares the same color LUT pool and that pool has only one color LUT in it as the argument visual, the visual is not matched by this criterion.

If either `hardCriteriaMask` of a criteria set is to 0, any visual will match that criteria set with a hard match. Likewise, setting the `softCriteriaMask` of a criteria set to 0, is sufficient to guarantee at least a soft match for that criteria set.

Selecting an Optimal Overlay/Underlay Visual Pair

The `XSolarisOvlSelectPair` routine is similar to `XSolarisOvlSelectPartner`. However, instead of selecting a partner visual given another visual, this routine simultaneously selects both the overlay and underlay visual from the set of all visual pairs for the given screen. The pair selected is the one that best matches the given criteria. The client is assured that, short of X errors not related to overlays, it can successfully create windows with the returned visuals.

This routine searches through all optimal visual pairs for a given screen, and then through all pairs of visuals (optimal and non-optimal), applying the specified criteria. These criteria are specified in `pCriteria`. Each element of `pCriteria` specifies criteria for both the overlay and underlay. It returns a success or failure status depending on whether it finds a pair that meets all the given criteria.

The selected pair has an overlay that satisfies all the hard criteria specified for the overlay. The pair has an underlay visual that satisfies all the hard criteria for the underlay. The attributes of the overlay visual are returned in `ovVisinfoReturn`. Likewise, the attributes of the underlay visual are specified in `unVisinfoReturn`. If two or more pairs are found that meet all of the hard criteria (both overlay and underlay) and the same number of soft criteria (either overlay or underlay), one of them will be chosen and returned. Which pair is chosen depends on the implementation.

The syntax and arguments are shown below.

```
XSolarisOvlSelectStatus
XSolarisOvlSelectPair (Display *display, int screen, int
numCriteria,
    XSolarisOvlPairCriteria *pCriteria,
    XVisualInfo *ovVisinfoReturn, XVisualInfo *unVisinfoReturn,
    unsigned long *unmetOvCriteriaReturn,
    unsigned long *unmetUnCriteriaReturn)
```

<code>display</code>	Specifies the connection to the X server.
<code>screen</code>	An integer specifying the screen on which the visuals are to be searched.
<code>numCriteria</code>	The number of <code>XSolarisOvlPairCriteria</code> structures in the <code>pCriteria</code> array.
<code>pCriteria</code>	An array of pair criteria structures in priority order from high to low specifying the criteria to be used in selecting the pair.
<code>ovVisinfoReturn</code>	A pointer to a caller-provided <code>XVisualInfo</code> structure. On successful return, this structure contains a description of the chosen overlay visual.
<code>unVisinfoReturn</code>	A pointer to a caller-provided <code>XVisualInfo</code> structure. On successful return, this structure contains a description of the chosen underlay visual.
<code>unmetOvCriteriaReturn</code>	A pointer to a bitmask that describes the criteria that were not satisfied for the overlay visual. This return argument is meaningful only when the routine returns a value of <code>XSolarisOvlQualifiedSuccess</code> , or <code>XSolarisOvlCriteriaFailure</code> .

`unmetUnCriteriaReturn` A pointer to a bitmask that describes the criteria that were not satisfied for the underlay visual. This return argument is meaningful only when the routine returns a value of `XSolarisOvlQualifiedSuccess`, or `XSolarisOvlCriteriaFailure`.

Argument Types

`XSolarisOvlPairCriteria` is a structure defining various criteria to be used during visual selection, along with indications of the stringency of the criteria. This structure is defined as:

```
typedef struct {
    XSolarisOvlVisualCriteria overlayCriteria;
    XSolarisOvlVisualCriteria underlayCriteria;
} XSolarisOvlPairCriteria;
```

`XSolarisOvlVisualCriteria` is defined in the specification of `XSolarisOvlSelectPartner`.

Return Types

Refer to the specification of `XSolarisOvlSelectPartner` for the definition of the type `XSolarisOvlSelectStatus`.

- `XSolarisOvlSuccess` is returned if the search is completely successful in finding a pair that meets all hard and soft criteria of one of the `XSolarisOvlPairCriteria` structures.
- `XSolarisOvlQualifiedSuccess` is returned if the chosen pair satisfies all hard criteria of one of the `XSolarisOvlPairCriteria` structures, but doesn't meet all soft criteria. In this case, `unmetOvCriteriaReturn` and `unmetUnCriteriaReturn` contain the logical OR of the soft criteria that were not met for the overlay and underlay, respectively.
- `XSolarisOvlCriteriaFailure` indicates that no pair could be found that meets all the hard criteria of any of the `XSolarisOvlPairCriteria` structures. In this case, `unmetOvCriteriaReturn` and

`unmetUnCriteriaReturn` contain the logical OR of the hard criteria that were not met by the `XSolarisOvlPairCriteria` structure with the fewest hard failures, for the overlay and underlay, respectively.

- `XSolarisOvlFailure` is returned if some other error is encountered besides criteria match failure.

Criteria Sets

Like `XSolarisOvlSelectPartner`, `XSolarisOvlSelectPair` supports a *degradation sequence* of criteria sets. This means that multiple criteria sets can be specified in a single call. First, the routine attempts to find a pair matching the first criteria set for both the overlay and the underlay. If it finds a pair that meets all of the hard criteria of the first set, it chooses this pair. If no pair meets all hard criteria of the first set, the routine searches using the second criteria set. This process continues until either a pair is found that meets all of the hard criteria of some criteria set, or all sets have been used to search. This degradation sequence allows clients to specify the criteria for the most preferred pair as the first criteria set. Pairs that are acceptable but less desirable can be specified in criteria sets following the first criteria set. This allows the search to proceed through a progressive relaxation in the client's requirements for the pair with a single subroutine call.

The criteria masks that can be specified are described in “Selecting a Visual for an Overlay/Underlay Window” on page 81.

The Solaris environment supports two access control mechanisms: user-based and host-based. It also supports two authorization protocols: MIT-MAGIC-COOKIE-1 and SUN-DES-1. This chapter discusses these access control mechanisms and authorization protocols. It also discusses how to change the server's access control, and how to run clients remotely, or locally as a different user.

Notes About This Chapter

If you run applications in any of the following configurations, you need to read this chapter:

- Linked with a version of `xlib` *previous* to OpenWindows Version 2 or X11R4. See “Host-Based” on page 92 for details.
- *Statically* linked to OpenWindows Version 2 libraries *and* you want to use the SUN-DES-1 authorization protocol. See “SUN-DES-1” on page 93 for details.
- On a remote server. See “Running Clients Remotely, or Locally as Another User” on page 98 for details.

If you are not using any of the configurations listed above, you do not need to change the default security setup.

Access Control Mechanisms

An access control mechanism controls which clients or applications have access to the OpenWindows server. Only properly authorized clients can connect to the server. All unauthorized X clients terminate with the following error message:

```
Xlib: connection to hostname refused by server
Xlib: Client is not authorized to connect to server
```

The server console displays the following message:

```
AUDIT: <Date Time Year>: X: client 6 rejected from IP 129.144.152.193 port 3485
Auth name: MIT-MAGIC-COOKIE-1
```

The two types of access control mechanisms are: *user-based* and *host-based*. Unless the `-noauth` option is used with `openwin`, both the user-based access control mechanism and the host-based access control mechanism are active. See “Manipulating Access to the Server” on page 95 for more information.

User-Based

A user-based, or authorization-based mechanism allows you to give access explicitly to a particular user on any host. The user’s client passes authorization data to the server. If the data matches the server’s authorization data, the user obtains access.

Host-Based

A host-based mechanism is a general purpose mechanism. It allows you to give access to a particular host, such that all users on that host can connect to the server. This is a weak form of access control; if a host has access to the server, all users on that host can connect to the server.

The Solaris environment provides the host-based mechanism for backward compatibility. Applications linked with a version of `Xlib` older than OpenWindows Version 2 or X11R4 do not recognize the new user-based access

control mechanism. To enable these applications to connect to the server, a user must either switch to the host-based mechanism, or relink with the newer version of `xlib`.

Note – If possible, clients linked with an older version of Xlib should be relinked with a newer version of Xlib. This enables them to connect to the server with the new user-based access control mechanism.

Authorization Protocols

The OpenWindows environment supports two different authorization protocols: MIT-MAGIC-COOKIE-1 and SUN-DES-1. While they differ in the authorization data used, they are similar in the access control mechanism used.

The MIT-MAGIC-COOKIE-1 protocol, using the user-based mechanism, is the OpenWindows environment default.

MIT-MAGIC-COOKIE-1

The MIT-MAGIC-COOKIE-1 authorization protocol was developed by the Massachusetts Institute of Technology (MIT). A *magic cookie* is a long, randomly generated binary password. At server startup, the magic cookie is created for the server and the user who started the system. On every connection attempt, the user's client sends the magic cookie to the server as part of the connection packet. This magic cookie is compared with the server's magic cookie. The connection is allowed if the magic cookies match, or denied if they do not match.

SUN-DES-1

The SUN-DES-1 authorization protocol was developed by Sun Microsystems. It is based on Secure Remote Procedure Call (RPC) and requires Data Encryption Software (DES) support. The authorization data is the machine-independent netname, or network name, of a user. This data is encrypted and sent to the server as part of the connection packet. The server decrypts the data, and, if the netname is known, allows the connection.

The SUN-DES-1 authorization protocol provides a higher level of security than the MIT-MAGIC-COOKIE-1 protocol. There is no way for another user to use your machine-independent netname to access a server, but it is possible for another user to use the magic cookie to access a server.

This protocol is available only in libraries in the OpenWindows Version 3 and later environments. Any applications built with static libraries, in particular Xlib, in environments prior to OpenWindows Version 3 cannot use this authorization protocol.

“Allowing Access When Using SUN-DES-1” on page 97 describes how to allow another user access to your server by adding their netname to your server’s access list.

Changing the Default Authorization Protocol

The default authorization protocol, MIT-MAGIC-COOKIE-1, can be changed to another supported authorization protocol or to no user-based access mechanism at all. The default is changed by supplying options with the `openwin` command. See the `openwin(1)` man page for more information.

For example, to change the default from MIT-MAGIC-COOKIE-1 to SUN-DES-1, start the OpenWindows environment as follows:

```
example% openwin -auth sun-des
```

If you must run OpenWindows without the user-based access mechanism, use the `-noauth` command line option.

```
example% openwin -noauth
```

Warning – Using `-noauth` weakens security. It is equivalent to running OpenWindows with only the host-based access control mechanism; the server inactivates the user-based access control mechanism. Anyone who can run applications on your local machine will be allowed access to your server.

Manipulating Access to the Server

Unless the `-noauth` option is used with `openwin` (see “Changing the Default Authorization Protocol” on page 94), both the user-based access control mechanism and the host-based access control mechanism are active. The server first checks the user-based mechanism, then the host-based mechanism. The default security configuration uses MIT-MAGIC-COOKIE-1 as the user-based mechanism, and an empty list for the host-based mechanism. Since the host-based list is empty, only the user-based mechanism is effectively active. Using the `-noauth` option instructs the server to inactivate the user-based access control mechanism and initializes the host-based list by adding the local host.

You can use either of two programs to change a server’s access control mechanism: `xhost` and `xauth`. For more information, see the man pages under `xhost` and `xauth`. These programs access two binary files created by the authorization protocol. These files contain session-specific authorization data. One file is for server internal use only. The other file is located in the user’s `$HOME` directory:

`.Xauthority` (Client Authority File)

Use the `xhost` program to change the host-based access list in the server. You can add hosts to, or delete hosts from the access list. If you start with the default configuration—an empty host-based access list—and use `xhost` to add a machine name, you lower the level of security. The server allows access to the host you added, as well as to any user specifying the default authorization protocol. See “Host-Based” on page 92 for an explanation of why the host-based access control mechanism is considered a lower level of security.

The `xauth` program accesses the authorization protocol data in the `.Xauthority` client file. You can extract this data from your `.Xauthority` file so that other users can merge the data into their `.Xauthority` file, thus allowing them access to your server, or to the server to which you connect.

See “Allowing Access When Using MIT-MAGIC-COOKIE-1” on page 97 for examples of how to use `xhost` and `xauth`.

Client Authority File

The client authority file is `.Xauthority`. It contains entries of the form:

<i>connection-protocol</i>	<i>auth-protocol</i>	<i>auth-data</i>
----------------------------	----------------------	------------------

By default, `.Xauthority` contains MIT-MAGIC-COOKIE-1 as the *auth-protocol*, and entries for the local display only as the *connection-protocol* and *auth-data*. For example, on host *anyhost*, the `.Xauthority` file may contain the following entries:

<i>anyhost:0</i>	MIT-MAGIC-COOKIE-1	82744f2c4850b03fce7ae47176e75
<i>localhost:0</i>	MIT-MAGIC-COOKIE-1	82744f2c4850b03fce7ae47176e75
<i>anyhost/unix:0</i>	MIT-MAGIC-COOKIE-1	82744f2c4850b03fce7ae47176e75

When the client starts up, an entry corresponding to the *connection-protocol* is read from `.Xauthority`, and the *auth-protocol* and *auth-data* are sent to the server as part of the connection packet. In the default configuration, `xhost` returns an empty host-based access list and states that the authorization is enabled.

If you have changed the authorization protocol from the default to SUN-DES-1, the entries in `.Xauthority` contain SUN-DES-1 as the *auth-protocol* and the netname of the user as the *auth-data*. The netname is in the following form:

`unix.userid@NISdomainname`

For example, on host, *anyhost* the `.Xauthority` file may contain the following entries:

<i>anyhost:0</i>	SUN-DES-1	"unix.15339@EBB.Eng.Sun.COM"
<i>localhost:0</i>	SUN-DES-1	"unix.15339@EBB.Eng.Sun.COM"
<i>anyhost/unix:0</i>	SUN-DES-1	"unix.15339@EBB.Eng.Sun.COM"

where `unix.15339@EBB.Eng.Sun.COM` is the machine-independent netname of the user.

Note – If you do not know your network name, or machine-independent netname, ask your system administrator.

Allowing Access When Using MIT-MAGIC-COOKIE-1

If you are using the MIT-MAGIC-COOKIE-1 authorization protocol, follow these steps to allow another user access to your server.

1. **On the machine running the server, use `xauth` to extract an entry corresponding to `hostname:0` into a file.**

For this example, *hostname* is *anyhost* and the file is *xauth.info*.

```
myhost% $OPENWINHOME/bin/xauth nextract - anyhost:0 > $HOME/xauth.info
```

2. **Send the file containing the entry to the user requesting access (using Mail Tool, `rarp`, or some other file transfer protocol).**

Note – Mailing the file containing your authorization information is a safer method than using `rarp`. If you do use `rarp`, do *not* place the file in a directory that is easily accessible by another user.

3. **The other user must merge the entry into their `.Xauthority` file.**

For this example, *userhost* merges *xauth.info* into their `.Xauthority` file.

```
userhost% $OPENWINHOME/bin/xauth mmerge - < xauth.info
```

Note – The *auth-data* is session-specific; therefore, it is valid only as long as the server is not restarted.

Allowing Access When Using SUN-DES-1

If you are using the SUN-DES-1 authorization protocol, follow these steps to allow another user access to your server.

1. **On the machine running the server, use `xhost` to make the new user known to the server.**

For example, to allow new user *somebody* to run on *myhost*, type:

```
myhost% xhost + somebody@
```

- 2. The new user must use `xauth` to add the entry into their `.Xauthority` file.**

For this example, the new user *somebody*'s machine-independent netname is `unix.15339@EBB.Eng.Sun.COM`.

```
userhost% echo 'add myhost:0 SUN-DES-1 "unix.15339@EBB.Eng.Sun.COM" ' | $OPENWINHOME/bin/xauth
```

Running Clients Remotely, or Locally as Another User

X clients use the value of the `DISPLAY` environment variable to get the name of the server to which they should connect.

To run clients remotely, or locally as another user, follow these steps:

- 1. On the machine running the server, allow another user access.**
Depending on which authorization protocol you use, follow the steps outlined in either “Allowing Access When Using MIT-MAGIC-COOKIE-1” on page 97 or “Allowing Access When Using SUN-DES-1” on page 97.
- 2. Set `DISPLAY` to the name of the host running the server.**
For this example, the host is *remotehost*.

```
myhost% setenv DISPLAY remotehost:0
```

- 3. Run the client program.**
The client is displayed on the remote machine, *remotehost*.

```
myhost% client_program&
```

Reference Display Devices



This appendix presents information on the Solaris reference display devices and the visuals they export. For more information on visuals, see Chapter 3, “Visuals on the Solaris X Server.”

Solaris Reference Display Devices

Certain display devices are considered to be *reference devices* in the Solaris environment. These devices have example device handlers provided in the Solaris Device Developer Kit (DDK). You can use the reference device handler example code as a template for your own device handler.

The process of writing and configuring a device handler is described in the *X Server Device Developer's Guide*. The Solaris X server supports any device for which a valid device handler is written and configured into the system.

Solaris Reference Devices and Visuals

Table A-1 lists the reference display devices and the visuals that they export. The device name specifies the display adapter to the server, and the product name specifies the type of display card. Note that if there is a distinct product name for a device, the product name is used in preference to the CG n device name (for example, TC is used, not CG8).

Exported depths specify the depths of the visuals advertised by the server for screens of this particular device type. MPG (Multiple Plane Group) indicates that the device supports multiple depth visuals. For other information on terms used in this table, see “Glossary” on page 105.

Table A-1 Solaris Reference Display Devices

Device Name	Product Name	Device Driver	Bus	Exported Depths
BW2	None	/dev/fbs/bwtwoX	SBus, VME/obio, P4	1-bit
CG3	None	/dev/fbs/cgthreeX	SBus	8-bit
CG6	GX	/dev/fbs/cgsixX	SBus, P4	8-bit
CG6	GXplus/ TurboGXplus	/dev/fbs/cgsixX	SBus	8-bit
CG8	TC	/dev/fbs/cgeightX	SBus, P4	1, 24-bit (MPG)
leo	LEO	/dev/fbs/leo0	SBus	1, 24-bit (MPG)
ffb	FFB	/dev/fbs/ffb0	SBus	1, 24-bit (MPG)
m64	PGX	/dev/fbs/m64X	PCI	8-bit
vga4	VGA	Not applicable	ISA, EISA, MCA	8-bit
vga8	VGA	Not applicable	ISA, EISA, MCA	8-bit
i8514	8514/A	Not applicable	ISA, EISA, MCAS	8-bit

Note – The server is configured to support a maximum of 16 displays; any limitations you might encounter are the number of frame buffers your hardware supports.

SPARC: Supported Reference Devices

BW2

The BW2 is a simple 1-bit frame buffer supporting monochrome monitors. The device handler for this device exports the 1-bit StaticGray visual only. Therefore, this is the built-in default visual. A variety of BW2 frame buffers are available for different buses and screen resolutions, including third-party offerings.

CG3

The CG3 is a simple 8-bit indexed color, dumb frame buffer for SBus systems. The device handler for this device exports several 8-bit visuals (listed in the following sections). The built-in default visual is 8-bit PseudoColor.

GX Family of Devices

The GX is an 8-bit indexed color graphics accelerator, specializing in 2D and 3D wireframe, flat-shaded polygon, and general window system acceleration. Window system acceleration is automatic; you can access other acceleration features through Solaris graphics APIs. Several 8-bit visuals are supported, and the built-in default visual is 8-bit PseudoColor. The GX is available for SBus and P4 bus.

The GXplus device is similar to the GX with additional memory that can be used for double buffering and expanded screen resolution on SBus systems. The Solaris X server uses the GXplus to automatically accelerate X11 pixmaps by using offscreen storage whenever possible.

TC (CG8)

The TC device possesses two separate memory buffers, or *plane groups*: 1-bit monochrome and 24-bit color. Windows may be created in both plane groups; therefore, it is an MPG device. All 1-bit and 24-bit visuals are supported.

Some (older) X11 client applications assume that color frame buffers use an 8-bit built-in default visual and do not run in color on the TC. To avoid this, the built-in default visual is 1-bit StaticGray.

The plane groups of the TC do not conflict with each other; they are completely separate memory buffers. OpenWindows takes advantage of this to increase system performance by not damaging 1-bit windows when they are occluded by 24-bit windows, and vice versa. This behavior is called *minimized exposure*. Use the `-nominexp` option of `openwin(1)` to disable this behavior. If this option is used, 1-bit windows will damage 24-bit windows and 24-bit windows may damage 1-bit windows.

The Solaris X server also provides minimized exposure for other MPG devices, when applicable. Use the `-nominexp` option of `openwin` with these devices.

Note – The X protocol states that cursor components can be arbitrarily transformed. To enhance general system performance, the OpenWindows server always renders the cursor in the 1-bit plane group of the TC.

x86: Supported Reference Devices

VGA

The VGA is a simple color dumb frame buffer. The server supports VGA as 8-bit indexed color with all visual types and a default of PseudoColor (vga8), or 4-bit StaticColor (vga4). When using 8-bit mode, the resolution is most often 1024x768. Four-bit mode is often limited to a resolution of 640x480 because this is the basic VGA graphics mode that is available on all VGA devices. Most VGAs provide a bitsPerRGB of 6. The vga8 server is also capable of supporting the XGA as a dumb frame buffer.

Support for VGA panning is available in modes of the 4-bit VGA. Panning mode provides the ability to have a physical window that maps onto a larger virtual display. Movement within the virtual display is performed by “pushing” the mouse past the edge of the screen. The display automatically moves the physical window in the virtual display in the direction that the mouse was pushed until the physical window touches the edge of the virtual boundary.

Use panning only if you are an experienced OpenWindows user. Icons and pop-up boxes (menus, dialogs, and so on) can appear off screen with no immediate visible notification. You must be experienced enough to recognize these situations, and be able to recover by looking for the hidden window objects. Pop-up pointer jumping is highly recommended while using panning. Virtual window managers, such as `olvwm` or `tvwm`, can cause additional confusion; do not use them.

8514/A

The 8514/A is an 8-bit indexed color graphics accelerator providing general window system acceleration. This device provides substantially improved performance compared to a VGA. The server limits its support of 8514/A to

8-bit indexed color and a resolution of 1024x768 or 1280x1024. It supports all 8-bit visuals. The built-in visual is 8-bit PseudoColor. Most 8514/A accelerators provide a bitsPerRGB of 6.

Glossary

Access Control Mechanism

An access control mechanism is a means of deciding which clients or applications have access to the OpenWindows server. There are two different types of access control mechanisms: user-based and host-based.

Bitmap

A bitmap is a rectangular array of elements, where each element holds either an *inside* value or an *outside* value.

Bitmap Font

A bitmap font is a collection of bitmaps with additional information (for example, character spacing) that defines how the bitmaps are to be used.

Bus

The bus is the system input/output (I/O) link. The display device is both physically and logically connected to the system by the bus. The SBus, VME, and P4 buses are used in SPARC systems. A third-party system may use a bus other than one of these three buses.

Client

A client is an application program that connects to the window server by some interprocess communication. It is referred to as a client of the window server. A client can run on the same machine as the window server or it can connect to a server running on another machine on the network. A client of the OpenWindows server must communicate via the X11 protocol.

Client-Server Model

The most commonly used paradigm when writing distributed applications is the client-server model. In this scheme, clients request services from a window server process. The client and server require a protocol that must be implemented at both ends of a connection. The OpenWindows server implements the X11 protocol.

Color Look-Up Table

A color look-up table is a hardware device that provides a mapping between pixel values and RGB color values. Also called a look-up table (LUT).

Colormap Flashing

Only one client colormap is installed at a given time. The windows that are associated with the installed colormap will show their correct colors. Windows that are associated with some other colormap may show false colors. This display of false colors is referred to as colormap flashing.

Composite Font

A composite font is a collection of base fonts organized hierarchically.

Connection

The communication path between a client and the server.

Default Visual

The default visual is one of the visuals available on the display device. When you start a client program, the program will usually run in the default visual unless a different visual is specified.

Display Device

Your monitor is connected to a display device that controls what is shown on the monitor. The display device includes memory (called a frame buffer) dedicated to storing display information. A display device is also referred to as a graphics adapter.

Device Driver

The device driver is the name of a device in the UNIX file system, where *X* is the number of that particular device on your system. For example, if a system had two CG3s, the first would be named `/dev/fbs/cgthree0`, and the second would be `/dev/fbs/cgthree1`. If a system had one CG3 and one GX, the CG3 would be `/dev/fbs/cgthree0` and the GX `/dev/fbs/cgsix0`.

Event

Clients are informed of information asynchronously by means of events. Events are grouped into types. A client must express interest in an event in order to receive that event from the server.

Extension

An extension to the core protocol can be defined to extend the functionality of the system.

Frame Buffer

Pixel data is typically stored in dedicated computer memory known as a frame buffer or video memory.

Graphics Accelerator

A display device that includes circuitry to increase the rate at which images are drawn into the frame buffer is called an accelerator, or graphics accelerator. A graphics accelerator often includes memory and circuitry that permits enhanced functionality, such as display of additional colors, 3D images, and animation.

Graphics Adapter

See Display Device.

Hardware Colormap

A hardware colormap is a color LUT. (See *also* Color Look-Up Table).

Look-Up Table

See Color Look-Up Table.

Multi-Depth Device

The TC display device provides visuals of different depths; it is referred to as a multiple plane group (MPG) or multi-depth device.

Multiple Plane Group

A display device that can simultaneously support more than one visual category is known as a multiple plane group (MPG) device.

Outline Font

An outline font is a collection of *ideal* shapes of characters. Each shape is defined numerically by continuous curve segments that separate the *inside* from the *outside* of the shape. This method is in use on high-resolution devices such as photo-typesetters.

Pixmap	A pixmap is a block of off-screen memory in the server; it is an array of pixel values.
Plane Group	The physical memory on a display device in which the pixel data is stored is commonly called a plane group.
Product Name	The product name identifies the type of display card.
Request	A request is a command to the server sent over a connection.
RGB	R, G, and B are the voltage levels to drive the red, green, and blue monitor guns, respectively.
Screen	A screen is a physical monitor and hardware, which is either color or black-and-white. A typical configuration could be a single keyboard and mouse shared among the screens.
Software Colormap	A software colormap is a software abstraction of the color mapping process that a color LUT provides. The software colormap can be loaded, or installed, into a hardware color LUT. Also called a colormap.
Virtual Colormap	A software colormap that is not visible until it is installed into a hardware color LUT.
Visual	A visual describes a way of interpreting a pixel value. The visual class and the pixel size attribute collectively describe a visual.
Visual Category	A visual category is a grouping of all visual classes of a given pixel size. The following visual categories are supported by OpenWindows: 1-bit, 4-bit, 8-bit, and 24-bit.
Visual Class	A visual class is how the pixel will be displayed as a color.

Window

A window provides a drawing surface to clients for text and graphics. A single client application can use multiple windows.

Window ID Table Descriptor

A window ID (WID) table contains descriptors for visual aspects of a pixel, such as whether it is an 8-bit pixel or a 24-bit pixel, which LUT should be used when displaying the pixel, and whether the pixel is double-buffered.

Window Manager

Manipulation of windows on the screen and much of the user interface (policy) is typically provided by a window manager client. The window manager communicates only with the window server.

Window Server

A window server, or display server such as the Solaris X server, is a program that handles the display capabilities of a machine and collects input from user devices and other clients, and sends events to clients. The server handles all communication with the window manager.

Index

Symbols

.Xauthority file 95–96

A

Adobe FTP site 23

Adobe public access file server 23

authorization protocols, *See* security

authorization-based access control
mechanism, *See* security

B

bdftopcf 46

bitmap distribution format 46

bitmap fonts 46–47

Black pixel location note 14

bus, used in SPARCsystems 105

BW2 display device, description of 100
See also display devices

C

CG3 display device, description of 101
See also display devices

CG6 display device, *See* GX display device
and GXplus display device

CG8 display device, *See* TC display device

client

running locally as another user 98

running remotely 98

client library

for DPS 18

color

color name database 14

recommendations 14

compose key support 13

compressing font files 47

contexts

and DPS 18

secure 21

three ways to share VM 21

D

DES (Data Encryption Software), with
SUN-DES-1 93

display devices

bus, used in Sun SPARCsystems 105

BW2

- description of 100
- CG3
 - description of 101
- CG6, *See* GX and GXplus
- CG8, *See* TC
- GT
 - window damage note 101
- GX
 - description of 101
- GXplus
 - description of 101
- programming hints 37
- supported devices table 100
- TC
 - description of 101

DISPLAY environment variable 98

Double Buffer Extension 5

DPS

- client library 18
- font enhancements 20
- libraries supported 20
- PostScript interpreter 18
- pswrap translator 18
- security issues 21

F

F3 fonts 48

font management library, definition of 3

fonts

- .afm file 45
- .enc file 46
- .map file 46
- .ps file 46
- .trans file 46
- .tmap file 46
- .upr file 46
- and X terminals 50

default font path in X11 49

files included in openwindows 45–46

formats 44–45

outline and bitmap 46, 47

replacing outline with bitmap 47

using F3 fonts 48

ftp program 4

ftp, accessing Adobe FTP site 23

G

GX display device, description of 101

See also display devices

GXplus display device, description of 101

See also display devices

H

host-based access control mechanism, *See* security

L

libraries

DPS, list of 20

X, list of 8

M

makebdf 46

MIT-MAGIC-COOKIE-1 authorization protocol, *See* security

MIT-SHM (Shared Memory) X extension 5

multiple plane group, characteristics of 37

N

NISdomainname, definition of 96

O

openwin command
 -noauth option 92, 94
outline fonts 46, 47
overlay windows
 advanced features
 background 59
 backing store 60
 border 60
 choosing visuals 62–63
 colormap 61
 gravity 60
 input distribution model 61
 print capture 62
 and existing pixel transfer routines 79–80
 and existing primitive rendering routines 69
 basic features
 creation 66
 definition 57–67
 viewability 58

P

portable compiled format 46
 compressed files 47
PostScript interpreter 18
pswrap translator 18

R

RPC (Remote Procedure Call), with SUN-DES-1 93

S

secure context creation 21
security 91–98

.Xauthority file 95–96, 97
 contents with MIT-MAGIC-COOKIE-1 96
 contents with SUN-DES-1 96
access control mechanisms 92–93
 definition of 92
 how both are active 95
authorization protocols 93–94
 default configuration 93
 default, how to change 94
authorization-based, *See* user-based clients
 running locally as another user 98
 running remotely 98
connection attempt error message 92
default configuration 93
determining if configuration change is required 91
host-based, backward compatibility 92
host-based, definition of 92
MIT-MAGIC-COOKIE-1
 authorization protocol 93
NISdomainname, definition of 96
-noauth option 92
 weakens security warning 94
server
 manipulating access 95–98
 allowing access with MIT-MAGIC-COOKIE-1 97
 allowing access with SUN-DES-1 97
SUN-DES-1 authorization protocol
 definition of 93–94
 need to reconfigure 91
user-based, definition of 92
userid, definition of 96

xauth program 95, 97
xhost program 97
server
 applications that run with 8
 architecture diagram 3
 DIX layer, definition of 3
 font management library, definition of 3
 manipulating access control 95–98
 OS layer, definition of 3
server overlays 51
SHAPE X extension 5
SUN-DES-1 authorization protocol, *See* security
system file access 21

T

TC display device, description of 101
See also display devices

U

user-based access control mechanism, *See* security

V

virtual memory 18
visuals
 default
 get with XGetVisualInfo function 36
 gamma-corrected 38–42
 multiple plane group, characteristics of 37
VM (virtual memory) 18, 21
 shared 18

W

White pixel location note 14

X

X

 applications not supported 10
 applications supported 9
 compose key 13
 extensions
 MIT-SHM (Shared Memory) 5
 SHAPE 5
 XInput 5
 XTEST 6
 libraries supported 8
 terminals and fonts 50
X Consortium
 extensions supported 4
xauth program 95, 97
XCopyArea, and overlay windows 80
XCopyPlane, and overlay windows 80
XDPSCreateSecureContext 22
XGetImage, and overlay windows 79
XGetVisualInfo function
 list default visual 36
xhost program 97
XInput X extension 5
XOvlSelectPair 86
XTEST X extension 6