

IBM TotalStorage LTO Ultrium 2 Tape Drive
Models T400 and T400F



Setup, Operator, and Service Guide

IBM TotalStorage LTO Ultrium 2 Tape Drive
Models T400 and T400F



Setup, Operator, and Service Guide

Note

Before using this guide and the product it supports, read the information in "Safety and Environmental Notices" on page vii and "Notices" on page 101.

First Edition (November 2002)

This edition applies to the *IBM TotalStorage LTO Ultrium 2 Tape Drive Models T400 and T400F Setup, Operator, and Service Guide* and to all subsequent releases and modifications until otherwise indicated in new editions.

© Copyright International Business Machines Corporation 2002. All rights reserved.

US Government Users Restricted Rights – Use, duplication or disclosure restricted by GSA ADP Schedule Contract with IBM Corp.

Contents

Safety and Environmental Notices	vii
Danger Notice	vii
Caution Notice	vii
Attention Notice	viii
Laser Safety and Compliance	viii
Preface	ix
Intended Audience	ix
Related Publications	ix
IBM Ultrium Publications	ix
IBM Fibre Channel Publications	ix
Other Publications	ix
Chapter 1. Introduction	1
Cartridge Compatibility	2
Speed Matching and Channel Calibration	2
Sleep Mode	2
Supported Servers and Operating Systems	3
SCSI Attachment	4
Physical Characteristics of the SCSI Interface	4
Speed	4
Address Assignments	5
Installing, Removing, or Resetting a Drive on an Active SCSI Bus	5
Fibre Channel Attachment	6
Supported Topologies	6
Speed	7
Address Assignments	7
World Wide Names	8
Physical Characteristics of the Fibre Channel Interface	8
Installing, Removing, or Resetting a Drive on an Active Fibre Channel	8
Supported Device Drivers	9
Chapter 2. Specifications	11
Chapter 3. Installing the Tape Drive	13
Rear View of the SCSI Drive	14
Rear View of the Fibre Channel Drive	15
Step 1. Unpack the Drive	16
Step 2. Remove Power from the Enclosure	16
Step 3. Set the SCSI ID or Arbitrated Loop Physical Address	17
Setting the SCSI ID (SCSI Drive Only)	17
Setting the Arbitrated Loop Physical Address (Fibre Channel Drive Only)	19
Step 4. Change the Link Services of the Drive (optional)	24
Step 5. Mount the Tape Drive into the Enclosure	26
Step 6. Connect and Test Power to the Tape Drive.	27
Step 7. Connect the Internal SCSI or Fibre Channel Cable.	27
Step 8. Connect the Internal LDI Cable (optional)	28
Step 9. Run Drive Diagnostics	28
Step 10. Install the Device Drivers.	28
Step 11. Connect the External SCSI or Fibre Channel Interface to the Server	28
Connect the External SCSI Interface to the Server	28
Connect the External Fibre Channel Interface to the Server	29
Step 12. Connect the External LDI Interface to the Server (optional)	29

Step 13. Configure the Tape Drive to the Server, Switch, or Hub.	29
Chapter 4. Operating the Tape Drive	31
Status Light	32
Unload Button	33
Single-Character Display	33
Single Red Dot	33
Inserting a Tape Cartridge	34
Removing a Tape Cartridge	35
Cleaning the Drive Head	35
Selecting a Diagnostic or Maintenance Function.	36
Exiting Maintenance Mode	45
Updating the Firmware	45
Updating Firmware through the SCSI or Fibre Channel Interface	45
Updating Firmware through the Library/Drive Interface	45
Updating the Firmware with an FMR Tape Cartridge	46
Chapter 5. Using the Media.	47
Data Cartridge	48
Cleaning Cartridges	49
Setting the Write-Protect Switch	50
Handling the Cartridges.	50
Provide Training	51
Ensure Proper Packaging	51
Provide Proper Acclimation and Environmental Conditions	52
Perform a Thorough Inspection	52
Handle the Cartridge Carefully	53
Examples of Cartridge Problems	54
Repositioning or Reattaching a Leader Pin.	55
Repositioning a Leader Pin	55
Reattaching a Leader Pin	57
Environmental and Shipping Specifications for Tape Cartridges	62
Disposing of Tape Cartridges.	63
Ordering Media Supplies	63
Ordering Custom Bar Code Labels	64
Chapter 6. Resolving Problems	65
Methods of Receiving Errors and Messages	66
Descriptions and Corrective Actions for Errors and Messages.	67
Using Sense Data.	71
Obtaining a Drive Dump	75
Viewing the Drive Error Log	76
Resolving Problems Reported by the Server	77
Fixing SCSI Bus Errors	77
Fixing Fibre Channel Errors	79
Resolving Media-Related Problems	82
Chapter 7. Servicing the Tape Drive	83
Removing a SCSI Tape Drive from an Enclosure	83
Removing a Fibre Channel Tape Drive from an Enclosure	84
Manually Removing a Tape Cartridge.	85
Removing the Cartridge	85
Fixing an Internal Jam	88
Appendix A. Tools and Supplies.	95

Appendix B. TapeAlert Flags	97
TapeAlert Flags Supported by the Drive.	97
Notices	101
Trademarks.	101
Electronic Emission Notices.	102
Special Considerations for Electromagnetic Compatibility	102
IBM TotalStorage LTO Ultrium 2 Tape Drive Models T400 and T400F	102
Getting Help	104
Warranty.	104
Glossary	105
Index	117

Safety and Environmental Notices

When using this product, observe the danger, caution, and attention notices that are contained in this guide. Symbols that represent the severity of the safety condition accompany the notices.

The sections that follow define each type of safety notice and give examples.

Danger Notice

A danger notice calls attention to a situation that is potentially lethal or extremely hazardous to people. A lightning bolt symbol always accompanies a danger notice to represent a dangerous electrical condition. A sample danger notice follows:



DANGER

An electrical outlet that is not correctly wired could place hazardous voltage on metal parts of the system or the products that attach to the system. It is the customer's responsibility to ensure that the outlet is correctly wired and grounded to prevent an electrical shock.

Caution Notice

A caution notice calls attention to a situation that is potentially hazardous to people because of some existing condition. One of several symbols can accompany a caution notice:

If the symbol is...	It means....
	A hazardous electrical condition with less severity than an electrical danger.
	A generally hazardous condition not represented by other safety symbols.
	A hazardous condition due to the use of a laser in the product. Laser symbols are always accompanied by the classification of the laser as defined by the U. S. Department of Health and Human Services (for example, Class I, Class II, and so forth).

Sample caution notices follow:



CAUTION:

The controller card contains a lithium battery. To avoid possible explosion, do not burn, exchange, or charge the battery. Discard the controller card as instructed by local regulations for lithium batteries.



CAUTION:

Do not attempt to use the handle on the module to lift the entire device (module and enclosure) as a unit. First remove the module; then, use two hands to lift the enclosure.

Attention Notice

An attention notice indicates the possibility of damage to a program, device, or system (server), or to data. An exclamation point symbol may accompany an attention notice, but is not required. Sample attention notices follow:



Attention: If you use a power screwdriver to perform this procedure it could destroy the tape.

Attention: Do not operate the Ultrium 2 Tape Drive in a poor air quality environment.

Laser Safety and Compliance

These products contain components that comply with performance standards that are set by the U.S. Food and Drug Administration (Part 21CFR, 1040.10/11). This means that these products belong to a class of laser products that do not emit hazardous laser radiation. This classification was accomplished by providing the necessary protective housing and scanning safeguards to ensure that laser radiation is inaccessible during operation or is within Class I limits. External safety agencies have reviewed these products and have obtained approvals to the latest standards as they apply to this product type.

Preface

Intended Audience

This book is intended primarily for integrators who install the IBM TotalStorage™ Linear Tape-Open (LTO) Ultrium 2 Tape Drive into an enclosure (such as a desktop unit, tape autoloader, or tape library). During operation of the enclosure, portions of the book may also be used by end users.

Related Publications

Refer to the following publications for additional information about the Ultrium 2 Tape Drive. To ensure that you have the latest publications, visit the web at <http://www.ibm.com/storage/lto>.

IBM Ultrium Publications

- *IBM TotalStorage LTO Ultrium Tape Drive SCSI Reference*, GA32-0450, provides the supported SCSI commands and protocol that govern the behavior of the SCSI interface for all models of the IBM Ultrium Tape Drive.
- *IBM TotalStorage LTO Ultrium 2 Tape Drive Quick Setup Guide*, GX35-5066, illustrates how to configure and operate the IBM TotalStorage LTO Ultrium 2 Tape Drive.
- *IBM Ultrium Device Drivers Installation and User's Guide*, GA32-0430, provides instructions for attaching IBM-supported hardware to Open Systems operating systems. It indicates what devices and levels of operating systems are supported, gives the requirements for adapter cards, and tells how to configure servers to use the device driver with the Ultrium family of devices.
- *IBM Ultrium Device Drivers Programming Reference*, GC35-0483, supplies information to application owners who want to integrate their Open Systems applications with IBM-supported Ultrium hardware. The reference contains information about the application programming interfaces (APIs) for each of the various supported operating-system environments.

IBM Fibre Channel Publications

- *Fibre Channel Storage Hub IBM 2103 Model H07 Installation, Service, and User's Guide*, SC26-7288
- *IBM SAN Fibre Channel Switch 2109 Model S08 User's Guide*, SC26-7349
- *IBM SAN Fibre Channel Switch 2109 Model S08 Installation and Service Guide*, SC26-7350
- *IBM SAN Fibre Channel Switch 2109 Model S16 User's Guide*, SC26-7351
- *IBM SAN Fibre Channel Switch 2109 Model S16 Installation and Service Guide*, SC26-7352

Other Publications

- *IBM Storage Area Network Gateway Module Setup, Operator, and Service Guide*, GA32-0436, describes the interface between devices and a storage area network or Fibre Channel server. The guide gives instructions for installation and operation of the unit, as well maintenance analysis procedures and a SCSI command reference.
- *IBM Library/Drive Interface Specification, Revision 4.1, August 29, 2002*, available from your OEM Sales Representative.

Chapter 1. Introduction

The IBM TotalStorage Linear Tape-Open (LTO) Ultrium 2 Tape Drive is a high-performance, high-capacity data-storage device that is designed to backup and restore Open Systems applications. The drive can be integrated into an enclosure, such as a desktop unit, tape autoloader, or tape library. The Ultrium 2 Tape Drive (called Generation 2) is the second-generation tape drive in the Ultrium series of products. It is available as Model T400 with a Small Computer Systems Interface (SCSI) or as Model T400F with a Fibre Channel interface.

The Ultrium 2 Tape Drive offers the following features:

- Native storage capacity of up to 200 GB per cartridge (400 GB assuming 2:1 LTO Data Compression)
- Native sustained data transfer rate of 35 MB per second (70 MB assuming 2:1 LTO Data Compression)

Table 1 gives additional features for each model of the drive.

Table 1. Features of the IBM TotalStorage LTO Ultrium 2 Tape Drive

Model T400 SCSI Interface	Model T400F Fibre Channel Interface
Ultra160 Low Voltage Differential (LVD) Small Computer Systems Interface	SCSI protocol carried on a 2-Gb Fibre Channel interface that supports switched fabric, arbitrated loop, and point-to-point topologies
68-pin, D-shell connector (for SCSI signals, SCSI ID selection, and power connection)	LC-duplex, short-wave connector for attachment to Storage Area Network (SAN) components
Burst data transfer rate of 160 MB per second	Burst data transfer rate of 200 MB per second

Figure 1 shows a front view of the IBM TotalStorage LTO Ultrium 2 Tape Drive with and without a bezel.

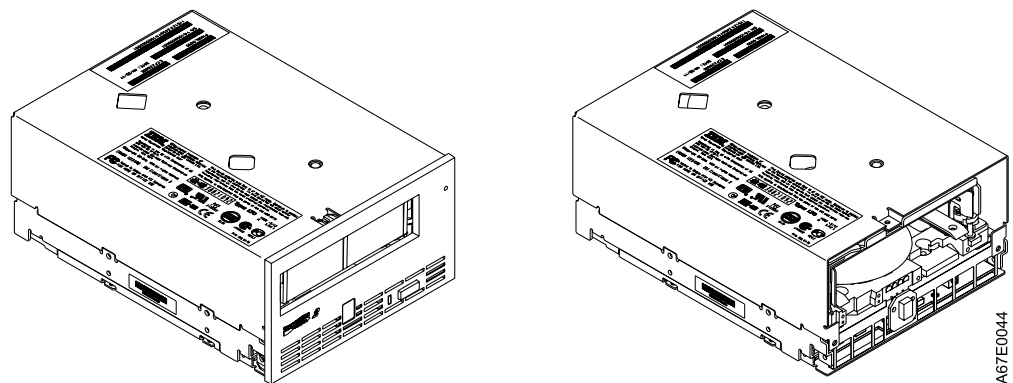

Figure 1. View of the IBM TotalStorage LTO Ultrium 2 Tape Drive with and without the bezel

Cartridge Compatibility

The Ultrium 2 Tape Drive (Generation 2) uses the IBM TotalStorage LTO Ultrium 200 GB Data Cartridge and is compatible with the cartridges of its predecessor, the IBM Ultrium Internal Tape Drive (called Generation 1). The Ultrium 2 Tape Drive performs the following functions:

- Reads and writes Generation 2 cartridges to Generation 2 format
- Reads and writes Generation 1 cartridges to Generation 1 format
- Does not write Generation 2 cartridges to Generation 1 format
- Does not write Generation 1 cartridges to Generation 2 format

The Ultrium 2 Tape Drive reads tapes that have been written by other licensed Ultrium 2 drives. It also writes to tapes that can be read by other licensed Ultrium 2 drives.

In addition to using the IBM TotalStorage LTO Ultrium Data Cartridge with up to 200 GB capacity, the Ultrium 2 Tape Drive also offers read/write capability for certified LTO Ultrium tape cartridges.

Speed Matching and Channel Calibration

To improve system performance, the Ultrium 2 Tape Drive uses a technique called *speed matching* to dynamically adjust its native (uncompressed) data rate to the slower data rate of a server. With speed matching, the drive operates at one of five speeds when reading or writing the Generation 2 cartridge format to achieve a native data rate of 17.5, 21.9, 26.25, 30.63, or 35 MB per second (MB/s). If the server's net (compressed) data rate is between two of the preceding native data rates, the drive calculates which of the two data rates at which to operate. (For example, if the server transfers data at 60 MB/s on the host bus, at 2:1 compression its net data rate is 30 MB/s. The drive will then dynamically choose to operate at a native data rate of 26.25 or 30.63 MB/s, whichever enables it to successfully receive the greatest amount of compressed data over the network.) Speed matching dramatically reduces backhitch, the condition that occurs when a tape stops, reverses, and restarts motion. A backhitch is usually the result of a mismatch between the data rates of the server and the drive.

System performance is further optimized by a feature called *channel calibration*, in which the drive automatically customizes each read/write data channel to compensate for variations in such things as the recording channel's transfer function, the media, and characteristics of the drive head.

Sleep Mode

To conserve energy when circuit functions are not needed for drive operation, the Ultrium 2 Tape Drive features a power-management function that causes the drive's electronics to enter a low-power mode known as *sleep mode*. To enter sleep mode, the drive must be inactive for a minimum of 15 minutes; to exit, the drive must receive a command across the SCSI or Fibre Channel interface, a command across the Library/Drive Interface (LDI or RS-422 interface), or a load or unload request. When in sleep mode, the drive's response time to commands that do not require media motion increases by up to 10 microseconds. Commands that require media motion may be delayed an additional 100 milliseconds because the tape must be retensioned.

Supported Servers and Operating Systems

The Ultrium 2 Tape Drive attaches to the servers and operating systems shown in Table 2. Any attachment can include (but is not limited to) these servers and operating systems. To determine the latest supported attachments, visit the web at <http://www.ibm.com/storage/1to>. For specific instructions about attaching the tape drive, see Chapter 3, "Installing the Tape Drive" on page 13.

Table 2. Supported servers and operating systems for SCSI and Fibre Channel attachment

Supported Servers	Supported Operating Systems
IBM AS/400® or @server iSeries™	OS/400®
IBM RS/6000®, RS/6000 SP™, or @server pSeries™	AIX®
IBM @server zSeries™ 800 or 900	Linux
Hewlett-Packard	HP-UX
Sun Microsystems	Solaris
32-bit, Intel-compatible servers	Microsoft®Windows® 2000 or Windows NT®
	Red Hat Linux
64-bit, Intel Itanium servers	Red Hat Linux
Supported SAN Components for Fibre Channel Attachment	
Visit the web at: http://www.storage.ibm.com/hardsoft/tape/supserver/support.html	

SCSI Attachment

To communicate with a server, the IBM TotalStorage LTO Ultrium 2 Tape Drive uses the Ultra160 LVD SCSI interface.

Physical Characteristics of the SCSI Interface

The Ultrium 2 Tape Drive contains a high-density, 68-pin, D-shell receptacle connector (HD68) for attachment to the server. The HD68 connector includes the connectors for the SCSI signal, the SCSI ID, and the drive's power. The drive supports LVD SCSI cables with HD68 connectors.

For a list of available cables, see Appendix A, "Tools and Supplies" on page 95.

Speed

The Ultra160 LVD SCSI interface is backward compatible with older SCSI technology and is capable of data transmission at 160 MB/s. Ultra160 SCSI uses the three management features of the Ultra3 SCSI standard that specifically affect data transfer rate:

- **Double transition clocking** - a data-transfer technique that enables data rates to double without increasing clock speed
- **Domain validation** - a procedure that detects and adjusts SCSI configuration issues that might prevent interoperation between SCSI devices
- **Cyclic redundancy check (CRC)** - an error-checking technique

Because the cables, connectors, and terminators are the same for the Ultra160 and Ultra2 SCSI interfaces, devices with those interfaces can be mixed on the same bus and each device can operate at its fully rated speed.

Address Assignments

Each device on a SCSI bus must have a SCSI identifier (ID) that identifies it to the server. When you install the Ultrium 2 Tape Drive, you can specify its SCSI ID in one of three ways:

- By attaching jumpers to the SCSI ID connector
- By using your enclosure's SCSI ID switch
- If you are installing the drive into a tape library, by setting the SCSI ID through the LDI or RS-422 interface

For more information, see "Setting the SCSI ID (SCSI Drive Only)" on page 17.

Installing, Removing, or Resetting a Drive on an Active SCSI Bus

You can attach an Ultrium 2 Tape Drive to an active SCSI bus. However, the preferred and safest method of adding, removing, or resetting a drive is to power-off the system.

When adding, removing, or resetting a drive on an active SCSI bus, perform the following steps:

1. Quiesce the drive. The drive to be added, removed, or reset must not be involved in any bus activity.
2. Disconnect power to the drive.
3. Connect or disconnect the SCSI bus cables to or from the drive's SCSI connector. Ensure that the SCSI bus remains intact from the server (initiator) to the terminator throughout the connection or disconnection process.

Note: Changing or moving the terminator disrupts the continuity of the SCSI bus and interrupts any process on the bus.

Fibre Channel Attachment



Attention: A Class I laser assembly, in the optical transceiver, is mounted on the Ultrium Fibre Channel electronics card. This laser assembly is registered with the Department of Health and Human Services and is in compliance with IEC825.

To communicate with a server, the Ultrium 2 Tape Drive has one Fibre Channel interface (also called a *port*). In accordance with the standards of the American National Standards Institute (ANSI), the port runs Fibre Channel Protocol (which includes SCSI commands on the Fibre Channel) with ANSI-defined Fibre Channel Tape Support. The method by which the drive and server communicate is determined by the type of topology in which they reside and the type of connection that you choose.

Supported Topologies

The Ultrium 2 Tape Drive can be attached in a two-node configuration, either directly to a switch as a public device (switched fabric) or directly to a host bus adapter (HBA) as a private device. It can do so in a Point-to-Point topology (through an N_port or F_port) or Arbitrated Loop topology (through an L_port or FL_port).

Unless you set the drive to force an explicit configuration (by using the FC configuration/status connector; see “Step 4. Change the Link Services of the Drive (optional)” on page 24), the Ultrium 2 Tape Drive automatically configures to an L_port or an N_port when it boots. The type of port to which it configures depends on whether the drive recognizes the connection as a loop or a point-to-point connection:

- An L_port supports a Fibre Channel Arbitrated Loop connection to an NL_port or FL_port.
- An N_port supports direct connection to another N_port or to an F_port (for example, a director-class switch) in a point-to-point topology.

Regardless of the port to which you connect the drive, it automatically configures to a public device (through an F_port or FL_port to a switch) or to a private device (through an N_port or L_port by using direct attachment to a server).

Table 3 lists the topologies in which the Ultrium 2 Tape Drive can operate, the Fibre Channel server connections that are available, and the port (NL, N, FL, or F) through which communication must occur.

Table 3. Choosing the port for your topology and Fibre Channel connection

Type of Topology	Type of Fibre Channel Connection to Server	
	Direct Connection (Private)	Switched Fabric (Public)
Fibre Channel-Arbitrated Loop (can be Two-Node Arbitrated Loop or Two-Node Switched Fabric Loop; is limited to two nodes)	L_Port	FL_Port
Point-to-Point (two nodes)	N_Port	F_Port

Speed

The Ultrium 2 Tape Drive's Fibre Channel interface facilitates data at 2 Gb/s (200 MB/s). It automatically negotiates to a rate of 1 Gb/s (100 MB/s) if the system or switch to which it connects does not support the 2-Gb rate (if this is the case, you may experience performance degradation). You can force the drive to an explicit speed by placing jumpers on the Fibre Channel (FC) configuration/status connector. For more information, see "Step 4. Change the Link Services of the Drive (optional)" on page 24.

Address Assignments

Each device on a Fibre Channel loop must have a Loop Identifier (LID) and a corresponding Arbitrated Loop Physical Address (AL_PA) to communicate with other devices in the topology. The AL_PA identifies the device on the loop. (LIDs and their corresponding AL_PAs are listed in Table 5 on page 21 and Table 6 on page 22.) You can set an AL_PA by using one of two methods known as *soft addressing* or *hard addressing*.

Soft addressing allows the drive to dynamically arbitrate the AL_PA with other Fibre Channel devices on the loop. Hard addressing allows you to choose the LID, which determines the corresponding AL_PA. The higher the AL_PA, the lower the priority of the device.

Generally, servers (initiators) require that devices use hard addressing; they do not support soft addressing. When setting addresses, assign the lowest AL_PA (and thus the highest priority) to the server; assign the highest AL_PA (and thus the lowest priority) to the drive.

To set soft or hard addressing, you must place jumpers on designated pins in the drive's LID/status connector (see (**2** in Figure 3 on page 15). The pin configuration for soft and hard addressing is defined in "Setting the Arbitrated Loop Physical Address (Fibre Channel Drive Only)" on page 19.

World Wide Names

Each Ultrium 2 Tape Drive has an 8-byte World Wide Node Name and an 8-byte World Wide Port Name that is assigned by IBM Manufacturing. The World Wide Node Name identifies the drive's SCSI logical unit; the World Wide Port Name identifies the physical port on the drive. An enclosure queries the World Wide Names through the LDI or RS-422 interface; a server queries the Names through the Fibre Channel interface. The Ultrium 2 Tape Drive reports the World Wide Names to switches. You can use the World Wide Node Name or Wide Node Port Name to uniquely identify the drive on a SAN.

When your Ultrium 2 Tape Drive is installed in a tape library, you can change the World Wide Node Name and World Wide Port Name through the LDI or RS-422 interface. For instructions, refer to the documentation for your tape library.

Physical Characteristics of the Fibre Channel Interface

The Ultrium 2 Tape Drive attaches to Open Systems servers by using short-wave, multimode fiber optic cables. All cables feature LC-duplex connectors and are designated as 50/125 (50 refers to the diameter of the optical fiber and 125 refers to the diameter of the cable; both are measured in micrometers).

For a list of available cables, see Appendix A, "Tools and Supplies" on page 95.

Installing, Removing, or Resetting a Drive on an Active Fibre Channel

A Fibre Channel network supports dynamic drive attachment. When adding, removing, or resetting a drive on an active server or SAN, perform the following steps:

1. Quiesce the drive. The drive to be added, removed, or reset must not be involved in activity.
2. Connect or disconnect the Fibre Channel cables to or from the drive.

Supported Device Drivers

IBM offers device drivers for the Ultrium 2 Tape Drive. Device drivers enable the drive to interact with a variety of servers. To properly install an IBM device driver (if required), refer to the *IBM Ultrium Device Drivers Installation and User's Guide*. For applications that use other device drivers, see the application's documentation to determine which drivers to use.

IBM maintains the latest levels of device drivers and driver documentation for the IBM TotalStorage LTO Ultrium 2 Tape Drive on the Internet. You can access this material from your browser or through the IBM FTP site by performing one of the following procedures. **(Note: If you do not have Internet access and you need information about device drivers, contact your Marketing Representative.)**

- Using a browser, type one of the following:
 - <http://www.ibm.com/storage>
 - <ftp://ftp.software.ibm.com/storage/devdrv>
 - <ftp://207.25.253.26/storage/devdrv>
- Using an IBM FTP site, enter the following specifications:
 - FTP site: [ftp.software.ibm.com](ftp://ftp.software.ibm.com)
 - IP Addr: 207.25.253.26
 - Userid: anonymous
 - Password: (use your current e-mail address)
 - Directory: /storage/devdrv

IBM provides PostScript- and PDF-formatted versions of its documentation in the /storage/devdrv/doc directory:

- [IBM_ultrium_tape_IUG.ps](#) and [IBM_ultrium_tape_IUG.pdf](#) contain the current version of the *IBM Ultrium Device Drivers Installation and User's Guide*
- [IBM_ultrium_tape_PROGREF.ps](#) and [IBM_ultrium_tape_PROGREF.pdf](#) contain the current version of the *IBM Ultrium Device Drivers Programming Reference*

Device drivers and utilities for each supported server are beneath /storage/devdrv/ in the following directories (the device driver for the iSeries or AS/400 server is included in the OS/400 operating system):

- AIX
- HPUX
- Linux
- Solaris
- Tru64
- WinNT
- Win2000

For more information about device drivers, refer to any of the preceding directories.

Chapter 2. Specifications

Table 4 gives the physical, power, and environmental specifications for the IBM TotalStorage LTO Ultrium 2 Tape Drive. Specifications for tape cartridges are given in “Environmental and Shipping Specifications for Tape Cartridges” on page 62.

Table 4. Specifications for the IBM TotalStorage LTO Ultrium 2 Tape Drive

Specification	Measurement	
Physical Specifications		
Width	146.0 mm (5.75 in.) without bezel	
	148.3 mm (5.84 in.) with bezel	
Length	205.5 mm (8.09 in.) without bezel	
	210.5 mm (8.29 in.) with bezel	
Height	82.5 mm (3.25 in.) without bezel	
	84.8 mm (3.34 in.) with bezel	
Weight (without a cartridge)	3 kg (6 lb 10 oz)	
Power Specifications		
	Drive with Ultra160 SCSI Interface	Drive with Fibre Channel Interface
Tolerance (see Note 1)	+ 5 Vdc and + 12 Vdc ($\pm 10\%$)	+ 5 Vdc and + 12 Vdc ($\pm 10\%$)
Power supply current for 5 Vdc (see Note 2)	1.3 A minimum	1.9 A minimum
	3.1 A maximum	3.7 A maximum
Power supply current for 12 Vdc (see Note 2)	0.2 A minimum	0.2 A minimum
	1.1 A maximum	1.1 A maximum
Power supply peak for 5 Vdc (the instantaneous power by the power supply)	3.3 A for 100 ms 15.5 W	3.9 A for 100 ms 19.5 W
Power supply peak for 12 Vdc (the instantaneous power by the power supply)	4.1 A for 2 ms 49.2 W	4.1 A for 2 ms 49.2 W
Power usage for typical idle mode with no cartridge	10.9 W	13.9 W
Power usage for typical idle mode with a cartridge loaded	12.7 W	15.7 W
Power usage for reading and writing at 6.22 m/s	29 W	32 W
Power usage for sleep mode with no cartridge	9.0 W	12.0 W
Power usage for sleep mode with a cartridge loaded	10.8 W	13.8 W
Other Specifications (for both interface types)		
Maximum altitude	3048 m (10,000 ft) for operating and storage	
	12192 m (40,000 ft) for shipping	
Extraction force	250 to 750 gms-force	

Table 4. Specifications for the IBM TotalStorage LTO Ultrium 2 Tape Drive (continued)

Environmental Specifications (for both interface types)			
Environmental Factor	Operating (see Note 3)	Storage	Shipping
Drive temperature	10 to 40°C (50 to 104°F)	1 to 60°C (33.8 to 140°F)	-40 to 60°C (-40 to 140°F)
Relative humidity (noncondensing)	20 to 80%	10 to 90%	10 to 90%
Wet bulb temperature	26°C (78.8°F)	26°C (78.8°F)	26°C (78.8°F)

Notes:

1. Measured at the drive's power connector.
2. The + 5 Vdc and + 12 Vdc maximum currents do not occur simultaneously. The Ultrium 2 Tape Drive monitors voltage and reports problems to the server.
3. Measured in front of the bezel, near the air intake area (refer to Figure 4 on page 16).

Chapter 3. Installing the Tape Drive

Attention:

To avoid static electricity damage when you handle the IBM TotalStorage LTO Ultrium 2 Tape Drive, use the following precautions:

- Limit your movement. Movement can cause static electricity to build around you.
- Always handle the Ultrium 2 Tape Drive carefully. Never touch exposed circuitry.
- Prevent others from touching the Ultrium 2 Tape Drive.
- Before you unpack and install the Ultrium 2 Tape Drive into an enclosure, touch its static-protective packaging to an unpainted metal surface on the enclosure for at least 2 seconds. This reduces static electricity in the packaging and your body.
- When possible, remove the Ultrium 2 Tape Drive from its static-protective packaging and install it directly into an enclosure without setting it down. When this is not possible, place the tape drive's packaging on a smooth, level surface and place the tape drive on the packaging.
- Do not place the Ultrium 2 Tape Drive on the cover of the enclosure or on any other metal surface.

The steps that follow describe how to install the Ultrium 2 Tape Drive into an enclosure.

Note: Depending on the type of enclosure, installation procedures may vary. Before starting this installation, read these instructions and compare them to the drive installation instructions for your enclosure.

When installing the Ultrium 2 Tape Drive into an enclosure, refer to "Rear View of the SCSI Drive" on page 14 or "Rear View of the Fibre Channel Drive" on page 15.

Rear View of the SCSI Drive

- 1** Feature switches
- 2** SCSI connector
- 3** SCSI ID connector
- 4** Power connector
- 5** Library/Drive Interface (LDI or RS-422 interface) connector

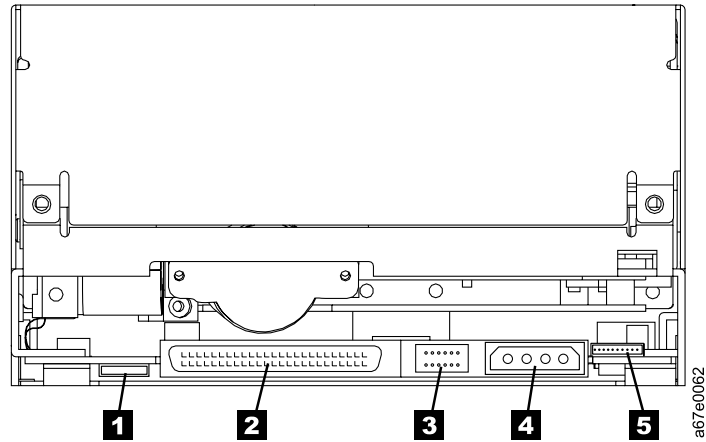

Figure 2. Rear view of the IBM TotalStorage LTO Ultrium 2 Tape Drive Model T400 (SCSI drive)

Rear View of the Fibre Channel Drive

- 1** Power connector
- 2** Feature switches
- 3** Loop identifier (LID)/status connector
- 4** Fibre Channel (FC) configuration/status connector
- 5** Fibre Channel connector
- 6** Library/Drive Interface (LDI or RS-422 interface) connector

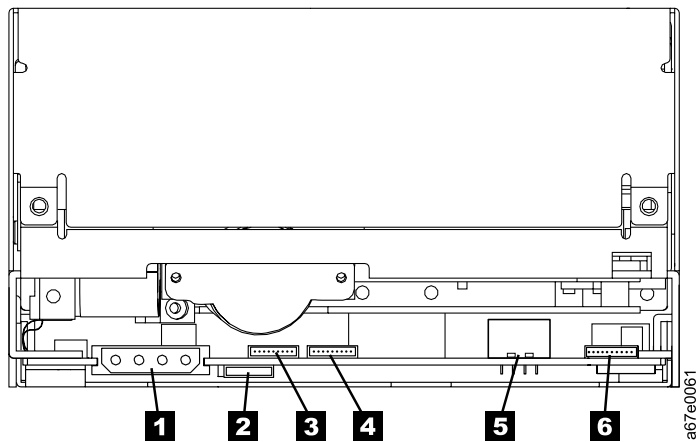

Figure 3. Rear view of the IBM TotalStorage LTO Ultrium 2 Tape Drive Model T400F (Fibre Channel drive)

Step 1. Unpack the Drive

Unpack the Ultrium 2 Tape Drive and store the packaging. You may need the packaging if you return the unit for service.

Attention::

Acclimation time is required if the temperature of the drive when unpacked is different than the temperature of its operating environment (measured at the front of the bezel near the air intake area; see Figure 4). The recommended acclimation time is 4 hours after the drive has been unpacked or 1 hour after any condensation that you can see has evaporated, whichever is greater. When acclimatizing the drive, apply the following measures:

- If the drive is colder than its operating environment and the air contains sufficient humidity, condensation may occur in the drive and damage it. When the drive has warmed to the operating temperature range (greater than 10°C or 50°F) and no danger of condensation is present (the air is dry), warm the drive more quickly by powering it on for 30 minutes. Use a diagnostic tape to test the drive before inserting a tape that contains data.
- If the drive is hotter than its operating environment, the tape can stick to the drive head. When the drive has cooled to the operating temperature range (less than 40°C or 104°F), cool the drive more quickly by applying airflow for 30 minutes. Power-on the drive and use a diagnostic tape to test it before inserting a tape that contains data.

If you are uncertain about whether the temperature of the drive is within the recommended operating range or the humidity is sufficient to cause condensation, acclimate the drive for the full 4 hours.

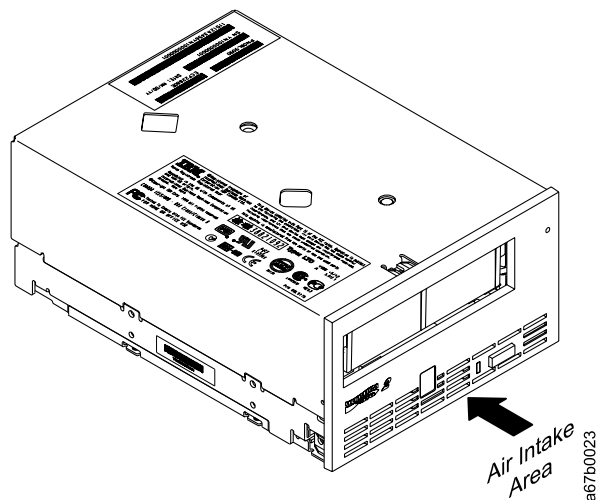

Figure 4. Measuring the temperature of the operating environment. The temperature is measured at the front of the bezel, near the air intake area.

Step 2. Remove Power from the Enclosure

- ___ 1. Power-off the enclosure (or the unit that provides power to the drive)
- ___ 2. Disconnect the power cord from both the electrical outlet and the enclosure.

Step 3. Set the SCSI ID or Arbitrated Loop Physical Address

Perform one of the following steps:

- If you are installing an Ultrium 2 Tape Drive that uses a SCSI interface (Model T400), you must set the drive's SCSI ID. For instructions, go to "Setting the SCSI ID (SCSI Drive Only)" on this page.
- If you are installing an Ultrium 2 Tape Drive that uses a Fibre Channel interface (Model T400F), you must set the drive's Arbitrated Loop Physical Address (AL_PA). For instructions, go to "Setting the Arbitrated Loop Physical Address (Fibre Channel Drive Only)" on page 19.

Setting the SCSI ID (SCSI Drive Only)

You can set the SCSI ID in one of three ways:

- By placing jumpers on the SCSI ID connector
- By using a SCSI ID switch that is connected to the SCSI ID connector
- By issuing a command from the library to set the SCSI ID through the drive's LDI interface

The sections that follow describe each method of setting the SCSI ID.

Setting the SCSI ID with Jumpers

You can set the SCSI ID on the Ultrium 2 Tape Drive by installing 2-mm jumpers on the drive's SCSI ID connector (see **3** in Figure 2 on page 14). Your tape drive may come set to a default SCSI configuration, with jumpers already installed. To change the default SCSI configuration, contact your sales or technical support representative. You can change the SCSI ID by rearranging, adding, or removing jumpers.

To set the SCSI ID:

- ___ 1. Locate the SCSI ID connector (see **3** in Figure 2 on page 14).
- ___ 2. Before attaching the SCSI bus cable to the server, decide the SCSI ID number that you want. Make sure that the ID is not being used by another device.
- ___ 3. Referring to Figure 5 on page 18, find the ID number that you chose then place jumpers on the connector pins as shown (use a pair of needle-nose pliers to connect the jumpers to the pins that are shaded).

Note: If you set the SCSI ID to 15, the drive will not necessarily be set to that ID; instead, the drive will expect to receive the SCSI ID through a command over its LDI interface.

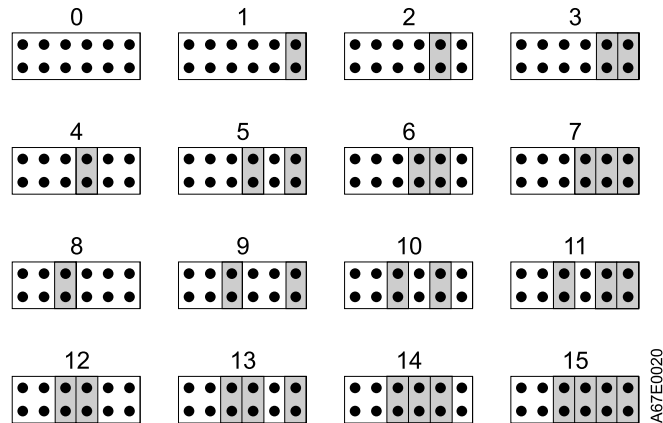

Figure 5. SCSI ID settings on the SCSI ID connector

Setting the SCSI ID with a SCSI ID Switch

If your enclosure uses a SCSI ID switch (rather than jumpers), connect the switch to the drive's SCSI ID connector (see **3** in Figure 2 on page 14). If any jumpers are pre-installed, be sure to remove them before connecting the switch. The SCSI ID switch must be compatible with the drive's SCSI ID connector and must make an electrical connection between the same pins as the jumpers to achieve the same corresponding SCSI ID.

Setting the SCSI ID Through the LDI Interface

If you are installing the Ultrium 2 Tape Drive into a tape library, you can issue a command from the library to set the drive's SCSI ID through the LDI interface. Make sure that the SCSI ID is set to 15 (see Figure 5). When configured to accept its SCSI ID through the LDI interface, the drive does not respond to SCSI commands until it receives a Set Configuration command through the interface.

Supplying TERMPower (SCSI Drive Only)

To supply TERMPower to the bus, locate one of the five jumpers shipped with the Ultrium 2 Tape Drive and place it on the SCSI ID connector as shown in the following figure. Place the jumper on the pins that are shaded.

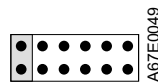

Note that you must provide SCSI termination externally to the Ultrium 2 Tape Drive.

Setting the Arbitrated Loop Physical Address (Fibre Channel Drive Only)

Each device on a Fibre Channel loop must have an Arbitrated Loop Physical Address (AL_PA) to communicate. The AL_PA identifies the device on the loop. To set the Ultrium 2 Tape Drive's AL_PA, you must place jumpers on specific pins in the drive's loop identifier (LID)/status connector. The placement of the jumpers indicates whether you want to choose the LID yourself (each LID corresponds to a specific AL_PA) or whether you want the drive to choose the AL_PA by arbitrating it with other devices on the loop. Valid LIDs and their corresponding AL_PAs are provided in this section.

Note: A Loop ID is part of a contiguous range of values; valid AL_PA values are not in a contiguous range.

In addition to establishing the AL_PA, by moving Feature Switch 3 on the drive to ON or off you can set the drive so that it provides one of the following functions:

- Status about the Fibre Channel loop (through the use of external indicators in an enclosure)
- Additional LIDs

The sections that follow describe how to select the AL_PA. They also describe how to set Feature Switch 3 so that the drive gives status about the loop or provides additional LIDs.

Setting the Loop ID to Provide Status About the Loop

If Feature Switch 3 on the Ultrium 2 Tape Drive is set to OFF (see **1** in Figure 6), the LID/status connector **2** has the following definition:

- Pins 1, 2, 3, 4, 7, and 8 are inputs and are used to set the LID.
 - Pins 5 and 6 are used as outputs:
 - Pin 5 has three states: *off* (ground), *on* (3.3 V), and *alternating* (between off and on). Pin 5 will be off if the drive does not detect light on the Fibre Channel connector, if (while communicating as an L_port) the drive does not complete the Loop Initialization Protocol (LIP), or if (while communicating as an N_port) the drive does not complete logging in to the host or switch. Pin 5 will be on if the drive detects light, successfully completes the LIP process, or logs in to another port. After the drive has completed the LIP process, the pin will be alternating when the drive is receiving SCSI commands, and the pin will be on when the drive is not receiving SCSI commands.
 - Pin 6 indicates that the drive detects light. If pin 6 is on but pin 5 is off, this could indicate communication problems across the fiber cable.
 - If the drive is installed in an enclosure, pins 5 and 6 may be used to support external indicators, such as light-emitting diodes (LEDs), on the enclosure.
- Note:** If indicators are used on an enclosure, the drive does not report error codes 8 and F (Fibre Channel problems) to the single-character display. Instead, pins 5 and 6 signal to the indicators that there is a problem.
- Pin 9 is ground.

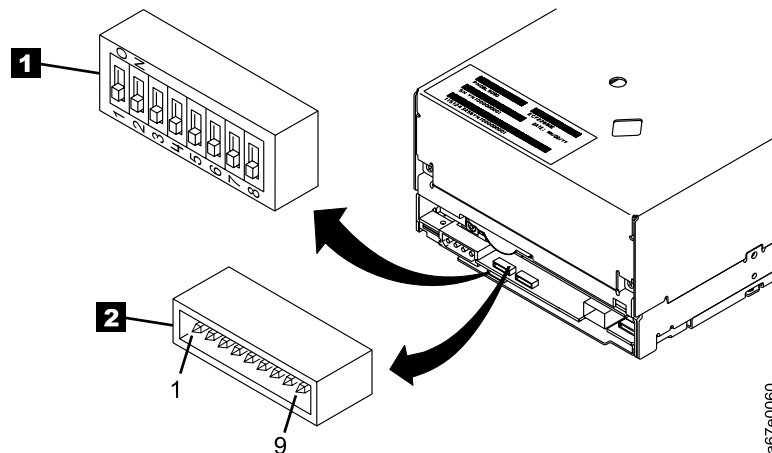

Figure 6. Setting the Loop ID and the AL_PA. The feature switches are located on the bottom of the drive.

To set the AL_PA:

1. Determine an unused AL_PA for the drive and refer to Table 5 on page 21 for its corresponding LID.
2. Locate the LID/status connector on the drive (see **2** in Figure 6).
3. Place jumpers on pins 1, 2, 3, 4, 7, and 8 as shown in Table 5 on page 21.

By using hard addressing, you can specify one of 62 valid AL_PAs for the drive. If you place jumpers on the four top and bottom pins on the right (a total of eight pins), the drive gets the AL_PA from a field in its vital product data (VPD). (A tape library can set the AL_PA in the VPD through the LDI interface.) If you do not place jumpers on any pins, the drive uses soft addressing to determine the AL_PA.

Table 5. ID Settings that provide status about the loop. The table lists the AL_PAs, corresponding LIDs, and definitions of the jumpers on the connector pins. Feature Switch 3 must be set to OFF.

AL_PA	LID	Pin (see Notes)						AL_PA	LID	Pin (see Notes)					
		1	2	3	4	7	8			1	2	3	4	7	8
use soft addressing	0	-	-	-	-	-	-	B2	20	G	-	-	-	-	-
E8	1	-	-	-	-	-	G	B1	21	G	-	-	-	-	G
E4	2	-	-	-	-	G	-	AE	22	G	-	-	-	G	-
E2	3	-	-	-	-	G	G	AD	23	G	-	-	-	G	G
E1	4	-	-	-	G	-	-	AC	24	G	-	-	G	-	-
E0	5	-	-	-	G	-	G	AB	25	G	-	-	G	-	G
DC	6	-	-	-	G	G	-	AA	26	G	-	-	G	G	-
DA	7	-	-	-	G	G	G	A9	27	G	-	-	G	G	G
D9	8	-	-	G	-	-	-	A7	28	G	-	G	-	-	-
D6	9	-	-	G	-	-	G	A6	29	G	-	G	-	-	G
D5	A	-	-	G	-	G	-	A5	2A	G	-	G	-	G	-
D4	B	-	-	G	-	G	G	A3	2B	G	-	G	-	G	G
D3	C	-	-	G	G	-	-	9F	2C	G	-	G	G	-	-
D2	D	-	-	G	G	-	G	9E	2D	G	-	G	G	-	G
D1	E	-	-	G	G	G	-	9D	2E	G	-	G	G	G	-
CE	F	-	-	G	G	G	G	9B	2F	G	-	G	G	G	G
CD	10	-	G	-	-	-	-	98	30	G	G	-	-	-	-
CC	11	-	G	-	-	-	G	97	31	G	G	-	-	-	G
CB	12	-	G	-	-	G	-	90	32	G	G	-	-	G	-
CA	13	-	G	-	-	G	G	8F	33	G	G	-	-	G	G
C9	14	-	G	-	G	-	-	88	34	G	G	-	G	-	-
C7	15	-	G	-	G	-	G	84	35	G	G	-	G	-	G
C6	16	-	G	-	G	G	-	82	36	G	G	-	G	G	-
C5	17	-	G	-	G	G	G	81	37	G	G	-	G	G	G
C3	18	-	G	G	-	-	-	80	38	G	G	G	-	-	-
BC	19	-	G	G	-	-	G	7C	39	G	G	G	-	-	G
BA	1A	-	G	G	-	G	-	7A	3A	G	G	G	-	G	-
B9	1B	-	G	G	-	G	G	79	3B	G	G	G	-	G	G
B6	1C	-	G	G	G	-	-	76	3C	G	G	G	G	-	-
B5	1D	-	G	G	G	-	G	75	3D	G	G	G	G	-	G
B4	1E	-	G	G	G	G	-	74	3E	G	G	G	G	G	-
B3	1F	-	G	G	G	G	G	use AL_PA from VPD	3F	G	G	G	G	G	G

Notes:

1. G means that the pin is jumpered to ground.
2. - means that the pin is not jumpered.

Setting the Loop ID to Provide Additional Loop IDs

If Feature Switch 3 on the Ultrium 2 Tape Drive is set to 0N (see **1** in Figure 6 on page 20), the LID/status connector **2** has the following definition:

- Pins 1 through 7 are used to set the LID.
- Pin 8 overrides pins 1 through 7. If you place a jumper on pin 8, the drive uses its vital product data (VPD) to set the AL_PA. A tape library can set the AL_PA in VPD through the LDI interface.
- Pin 9 is ground.

Note: Feature Switch 3 does not support LEDs on an enclosure. Therefore, when Feature Switch 3 is set to 0N, the drive can report Fibre Channel problems (error codes 8 and F) on the single-character display, but not by using the enclosure's external indicators.

To set the AL_PA:

1. Determine an unused AL_PA address for the drive and refer to Table 6 for its corresponding LID.
2. Locate the LID/status connector on the drive (see **2** in Figure 6 on page 20).
3. Place jumpers on pins 1 through 7 as shown in Table 6 or on pin 8.

Table 6. ID settings that provide additional Loop IDs. The table lists the AL_PAs, corresponding LIDs, and definitions of the jumpers on the connector pins. Feature Switch 3 must be set to 0N.

AL_PA	LID	Pin (see Notes)						
		1	2	3	4	5	6	7
EF	0	-	-	-	-	-	-	-
E8	1	-	-	-	-	-	-	G
E4	2	-	-	-	-	-	G	-
E2	3	-	-	-	-	-	G	G
E1	4	-	-	-	-	G	-	-
E0	5	-	-	-	-	G	-	G
DC	6	-	-	-	-	G	G	-
DA	7	-	-	-	-	G	G	G
D9	8	-	-	-	G	-	-	-
D6	9	-	-	-	G	-	-	G
D5	A	-	-	-	G	-	G	-
D4	B	-	-	-	G	-	G	G
D3	C	-	-	-	G	G	-	-
D2	D	-	-	-	G	G	-	G
D1	E	-	-	-	G	G	G	-
CE	F	-	-	-	G	G	G	G
CD	10	-	-	G	-	-	-	-
CC	11	-	-	G	-	-	-	G
CB	12	-	-	G	-	-	G	-
CA	13	-	-	G	-	-	G	G
C9	14	-	-	G	-	G	-	-
C7	15	-	-	G	-	G	-	G
C6	16	-	-	G	-	G	G	-

AL_PA	LID	Pin (see Notes)						
		1	2	3	4	5	6	7
B1	21	-	G	-	-	-	-	G
AE	22	-	G	-	-	-	G	-
AD	23	-	G	-	-	-	G	G
AC	24	-	G	-	-	G	-	-
AB	25	-	G	-	-	G	-	G
AA	26	-	G	-	-	G	G	-
A9	27	-	G	-	-	G	G	G
A7	28	-	G	-	G	-	-	-
A6	29	-	G	-	G	-	-	G
A5	2A	-	G	-	G	-	G	-
A3	2B	-	G	-	G	-	G	G
9F	2C	-	G	-	G	G	-	-
9E	2D	-	G	-	G	G	-	G
9D	2E	-	G	-	G	G	G	-
9B	2F	-	G	-	G	G	G	G
98	30	-	G	G	-	-	-	-
97	31	-	G	G	-	-	-	G
90	32	-	G	G	-	-	G	-
8F	33	-	G	G	-	-	G	G
88	34	-	G	G	-	G	-	-
84	35	-	G	G	-	G	-	G
82	36	-	G	G	-	G	G	-
81	37	-	G	G	-	G	G	G

Table 6. ID settings that provide additional Loop IDs (continued). The table lists the AL_PAs, corresponding LIDs, and definitions of the jumpers on the connector pins. Feature Switch 3 must be set to 0N.

AL_PA	LID	Pin (see Notes)							AL_PA	LID	Pin (see Notes)						
		1	2	3	4	5	6	7			1	2	3	4	5	6	7
C5	17	-	-	G	-	G	G	G	80	38	-	G	G	G	-	-	-
C3	18	-	-	G	G	-	-	-	7C	39	-	G	G	G	-	-	G
BC	19	-	-	G	G	-	-	G	7A	3A	-	G	G	G	-	G	-
BA	1A	-	-	G	G	-	G	-	79	3B	-	G	G	G	-	G	G
B9	1B	-	-	G	G	-	G	G	76	3C	-	G	G	G	G	-	-
B6	1C	-	-	G	G	G	-	-	75	3D	-	G	G	G	G	-	G
B5	1D	-	-	G	G	G	-	G	74	3E	-	G	G	G	G	G	-
B4	1E	-	-	G	G	G	G	-	73	3F	-	G	G	G	G	G	G
B3	1F	-	-	G	G	G	G	G	72	40	G	-	-	-	-	-	-
B2	20	-	G	-	-	-	-	-	71	41	G	-	-	-	-	-	G
6E	42	G	-	-	-	-	G	-	39	61	G	G	-	-	-	-	G
6D	43	G	-	-	-	-	G	G	36	62	G	G	-	-	-	G	-
6C	44	G	-	-	-	-	G	-	35	63	G	G	-	-	-	G	G
6B	45	G	-	-	-	G	-	G	34	64	G	G	-	-	G	-	-
6A	46	G	-	-	-	G	G	-	33	65	G	G	-	-	G	-	G
69	47	G	-	-	-	G	G	G	32	66	G	G	-	-	G	G	-
67	48	G	-	-	G	-	-	-	31	67	G	G	-	-	G	G	G
66	49	G	-	-	G	-	-	G	2E	68	G	G	-	G	-	-	-
65	4A	G	-	-	G	-	G	-	2D	69	G	G	-	G	-	-	G
63	4B	G	-	-	G	-	G	G	2C	6A	G	G	-	G	-	G	-
5C	4C	G	-	-	G	G	-	-	2B	6B	G	G	-	G	-	G	G
5A	4D	G	-	-	G	G	-	G	2A	6C	G	G	-	G	G	-	-
59	4E	G	-	-	G	G	G	-	29	6D	G	G	-	G	G	-	G
56	4F	G	-	-	G	G	G	G	27	6E	G	G	-	G	G	G	-
55	50	G	-	G	-	-	-	-	26	6F	G	G	-	G	G	G	G
54	51	G	-	G	-	-	-	G	25	70	G	G	G	-	-	-	-
53	52	G	-	G	-	-	G	-	23	71	G	G	G	-	-	-	G
52	53	G	-	G	-	-	G	G	1F	72	G	G	G	-	-	G	-
51	54	G	-	G	-	G	-	-	1E	73	G	G	G	-	-	G	G
4E	55	G	-	G	-	G	-	G	1D	74	G	G	G	-	G	-	-
4D	56	G	-	G	-	G	G	-	1B	75	G	G	G	-	G	-	G
4C	57	G	-	G	-	G	G	G	18	76	G	G	G	-	G	G	-
4B	58	G	-	G	G	-	-	-	17	77	G	G	G	-	G	G	G
4A	59	G	-	G	G	-	-	G	10	78	G	G	G	G	-	-	-
49	5A	G	-	G	G	-	G	-	0F	79	G	G	G	G	-	-	G
47	5B	G	-	G	G	-	G	G	08	7A	G	G	G	G	-	G	-
46	5C	G	-	G	G	G	-	-	04	7B	G	G	G	G	-	G	G
45	5D	G	-	G	G	G	-	G	02	7C	G	G	G	G	G	-	-
43	5E	G	-	G	G	G	G	-	01	7D	G	G	G	G	G	-	G

Table 6. ID settings that provide additional Loop IDs (continued). The table lists the AL_PAs, corresponding LIDs, and definitions of the jumpers on the connector pins. Feature Switch 3 must be set to ON.

AL_PA	LID	Pin (see Notes)						
		1	2	3	4	5	6	7
3C	5F	G	-	G	G	G	G	G
3A	60	G	G	-	-	-	-	-

AL_PA	LID	Pin (see Notes)						
		1	2	3	4	5	6	7
SA	7E	G	G	G	G	G	G	-
SA	7F	G	G	G	G	G	G	G

Notes:

1. G means that the pin is jumpered to ground.
2. - means that the pin is not jumpered.
3. SA means soft addressing.

Step 4. Change the Link Services of the Drive (optional)

You can optionally change the link services (for example, the speed and type of topology) of your Fibre Channel drive. If you choose not to alter the link services, the drive defaults to a negotiated speed and operation in an FC-AL topology with a direct connection to the server.

In the following procedure, note that:

- Pin 5 is disconnected and is not represented in Table 7.
- Pin 9 is ground.

To change the type of topology and the speed of the Fibre Channel drive:

1. Determine the type of topology in which you want to operate the Ultrium 2 Tape Drive and refer to Table 7 for its corresponding pin configuration.
2. Determine the speed at which you want the Ultrium 2 Tape Drive to operate and refer to Table 7 for its corresponding pin configuration.
3. Locate the Fibre Channel (FC) configuration/status connector on the drive (see **1** in Figure 7 on page 25).
4. Place jumpers on the pins that you identified in steps 1 and 2.

Table 7. Topology and speed settings for the Ultrium 2 Tape Drive

Fibre Channel Characteristic	Pin				
	1	2	3	4	5 through 8
Speed Selection					
Drive uses VPD values that can be updated by the LDI or RS-422 (the default value is Negotiated)	-	-	X	X	X
2 Gb (200 MB/s)	-	G	X	X	X
1 Gb (100 MB/s)	G	-	X	X	X
Negotiated (the drive automatically negotiates to the highest common speed)	G	G	X	X	X
Topology Selection					
Drive uses VPD values that can be updated by the LDI or RS-422 (the default value is the NL_port)	X	X	-	-	X

Table 7. Topology and speed settings for the Ultrium 2 Tape Drive (continued)

Fibre Channel Characteristic	Pin				
	1	2	3	4	5 through 8
L_Port	X	X	-	G	X
N_Port	X	X	G	-	X
NL_Port (the drive automatically selects and configures the topology)	X	X	G	G	X

Notes:

1. G means that the pin is jumpered to ground.
2. - means that the pin is not jumpered.
3. X means that the setting of the pin does not matter.

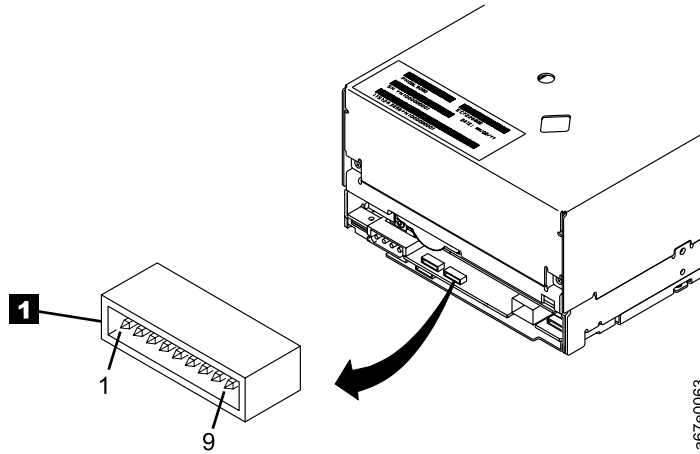

Figure 7. Location of the Fibre Channel (FC) configuration/status connector. The view is from the rear of the drive.

Step 5. Mount the Tape Drive into the Enclosure

The Ultrium 2 Tape Drive may be shipped with or without a front bezel (see **1** in Figure 8).

To mount the Ultrium 2 Tape Drive into an enclosure:

- ___ 1. Remove the cover of your enclosure (refer to the instructions in the enclosure's documentation).
- ___ 2. Place the drive into the enclosure so that its tape load compartment faces the tape load compartment of the enclosure.
- ___ 3. Insert two 6-32 screws into the mounting holes **2** on the side brackets of the chassis.

Attention: When inserted into the Ultrium 2 Tape Drive, the length of the mounting screws must not exceed 3.5 mm (0.14 in.) inside the chassis. If the length exceeds this measurement, the tape drive may become damaged.

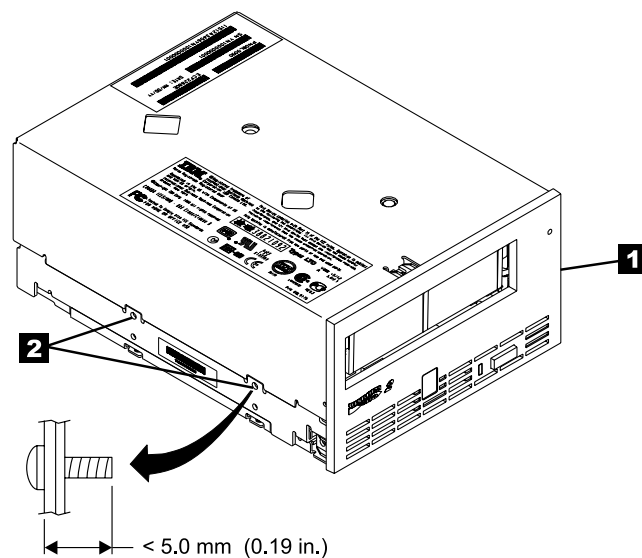

Figure 8. Mounting holes on Ultrium 2 Tape Drive. The holes are located on both sides of the drive. The tape drive is shown with a front bezel.

Step 6. Connect and Test Power to the Tape Drive

The Ultrium 2 Tape Drive does not contain its own power source; it must be powered externally.

To connect and test power to the Ultrium 2 Tape Drive:

- ___ 1. Ensure that the enclosure (or unit that supplies power to the drive) is powered off.
 - ___ 2. Ensure that the power cord is disconnected from both the enclosure and the power outlet.
 - ___ 3. Connect the enclosure's internal power cable to the power connector on the drive (if you are using a SCSI drive, see **4** in Figure 2 on page 14; if you are using Fibre Channel drive, see **1** in Figure 3 on page 15). Ensure that the connector is properly connected.
 - ___ 4. Connect the power cord to the enclosure and to the electrical outlet.
 - ___ 5. Review the location of the single-character display and the status light on page 31 (if your drive does not have a bezel, note that the bulb of the status light is recessed and the light is not visible until lit). To ensure that the drive is receiving power, watch for the following while turning on the power to the enclosure:
 - The single-character display presents a series of random characters, then becomes blank (not lit).
- Note: If the single-character display does not come on, the drive may not be getting power.**
- The status light briefly becomes solid amber, then becomes solid green.
 - ___ 6. Power-off the enclosure.
 - ___ 7. Disconnect the power cord from both the enclosure and the electrical outlet.

Step 7. Connect the Internal SCSI or Fibre Channel Cable

- ___ 1. Perform one of the following procedures:
 - If you are using a SCSI drive (Model T400), connect the enclosure's internal SCSI cable to the SCSI connector on the drive (see **2** in Figure 2 on page 14).
 - If you are using a Fibre Channel drive (Model T400F), connect the enclosure's internal Fibre Channel cable to the Fibre Channel connector on the drive (see **5** in Figure 3 on page 15).
- ___ 2. Ensure that the connector is properly connected.

Step 8. Connect the Internal LDI Cable (optional)

Note: Use this step only if you are installing the Ultrium 2 Tape Drive into a library control system. The drive uses the Library/Drive Interface (LDI) to communicate with a tape library.

Connect the enclosure's internal LDI cable to the LDI connector on the drive (see **5** in Figure 2 on page 14 or **6** in Figure 3 on page 15).

Step 9. Run Drive Diagnostics

- ___ 1. Replace the cover on the enclosure.
- ___ 2. Connect the power cord to both the enclosure and the electrical outlet, then power-on the enclosure.
- ___ 3. Run one or more of the following tape drive diagnostics. If an error code appears on the single-character display, go to Table 15 on page 67.
 - Function Code 1 - Run Tape Drive Diagnostics (see page 36).
 - Function Code 6 - Run Wrap Test (for a SCSI drive, see page 39; for a Fibre Channel drive, see page 40).
 - Function Code 7 - Run LDI Wrap Test (see page 41).
- ___ 4. Power-off the enclosure, then disconnect the power cord from both the enclosure and the electrical outlet.

Step 10. Install the Device Drivers

For information about installing device drivers, refer to the documentation for your enclosure.

Step 11. Connect the External SCSI or Fibre Channel Interface to the Server

Perform one of the following steps:

- If you are using a SCSI drive (Model T400), connect the enclosure's external SCSI cable to the SCSI connector on the server. For instructions, go to "Connect the External SCSI Interface to the Server" on this page.
- If you are using a Fibre Channel drive (Model T400F), connect the enclosure's external Fibre Channel cable to the Fibre Channel connector on the server. For instructions, go to "Connect the External Fibre Channel Interface to the Server" on page 29.

Connect the External SCSI Interface to the Server

To connect the enclosure to the SCSI bus:

- ___ 1. Connect an external SCSI bus cable to both the enclosure and the server (for the location of the connectors, refer to the documentation for your enclosure and server).
- ___ 2. Run the appropriate SCSI attachment verification procedure from your server (for instructions, refer to the *IBM Ultrium Device Drivers Installation and User's Guide*). If a SCSI error occurs, refer to "Using Sense Data" on page 71.

If you want to power a device on or off while it is connected to the same SCSI bus as an Ultrium 2 Tape Drive, you can do so if, during the power-on cycle, you quiesce all devices (including the Ultrium 2 Tape Drive) on the bus.

Connect the External Fibre Channel Interface to the Server

To connect the enclosure to the Fibre Channel interface:

1. Connect an external fiber cable to both the enclosure and the appropriate attachment (server, switch, or hub). For the location of the connectors and for information about attaching the fiber cable, refer to the documentation for your enclosure and for your server, switch, or hub.

Note: A drive with a Fibre Channel interface can be ordered with several lengths of fiber cabling, up to 61 m (200 ft). For ordering information, see Table 16 on page 95.

2. Run the appropriate Fibre Channel attachment verification procedure from your server (for instructions, refer to the *IBM Ultrium Device Drivers Installation and User's Guide*). If a SCSI error occurs, refer to "Using Sense Data" on page 71.

Step 12. Connect the External LDI Interface to the Server (optional)

Use this step only if your enclosure requires an LDI interface.

To perform a checkout of the Ultrium 2 Tape Drive, connect the enclosure's external LDI cable to the server (for the location of the external LDI connector, refer to the documentation for the enclosure).

Step 13. Configure the Tape Drive to the Server, Switch, or Hub

To configure the SCSI tape drive (Model T400) to the server, or to configure the Fibre Channel drive (Model T400F) to a server, switch, or hub, refer to the documentation for that server, switch, or hub.

Chapter 4. Operating the Tape Drive

When operating the Ultrium 2 Tape Drive, refer to Figure 9 which shows the front of the unit.

- 1** Status light
- 2** Unload button
- 3** Single-character display
- 4** Single red dot

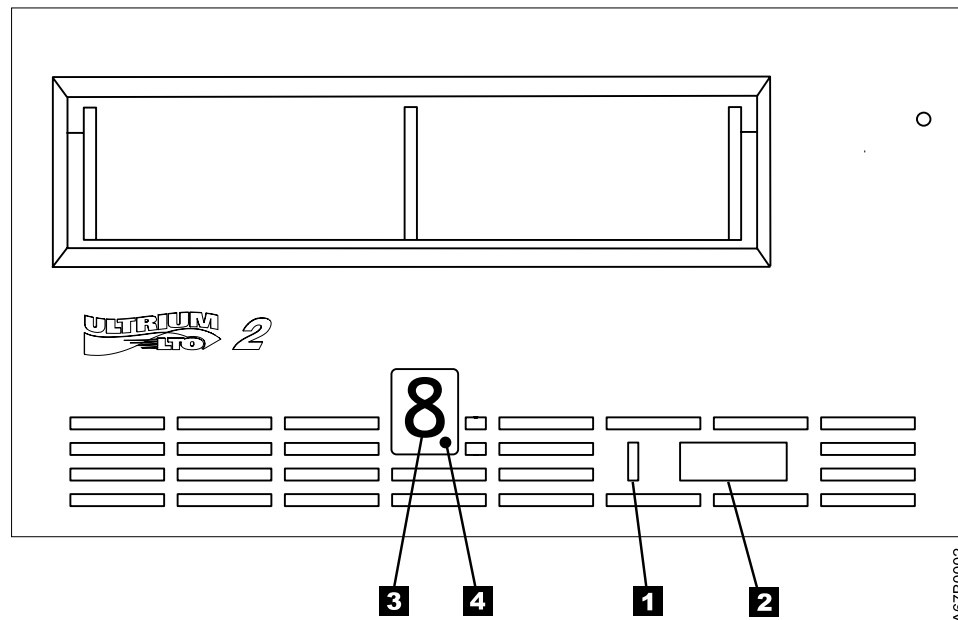

Figure 9. Front view of the IBM TotalStorage LTO Ultrium 2 Tape Drive

Status Light

The status light (**1** in Figure 9 on page 31) is a light-emitting diode (LED) that provides information about the state of the Ultrium 2 Tape Drive. The light can be green or amber, and (when lit) solid or flashing. Table 8 lists the conditions of the status light and provides an explanation of what each condition means.

Table 8. Meaning of Status Light Activity

Color and Condition of Status Light	Meaning
Off	The tape drive has no power or is powered off.
Green/Solid	The tape drive is powered on and is idle.
Green/Flashing	<p>The tape drive is reading from the tape, writing to the tape, rewinding the tape, locating data on the tape, loading the tape, or unloading the tape.</p> <p>The status light also flashes green if the tape drive contains a cartridge during the power-on cycle. In this case, the drive completes POST and slowly rewinds the tape (the process may take approximately 13 minutes). The light stops blinking and becomes solid when the drive completes the recovery and is ready for a read or write operation. To eject the cartridge, press the unload button.</p>
Amber/Solid	The tape drive is powering on, is resetting, or is in maintenance mode. For information about the functions that are available when the drive is in maintenance mode, see “Selecting a Diagnostic or Maintenance Function” on page 36.
Amber/Flashing	<p>One of the following applies:</p> <ul style="list-style-type: none">• If the light flashes once per second, an error occurred and the tape drive or media may require service. Note the code on the single-character display, then go to Table 15 on page 67 to determine the action that is required. If a solid C appears in the single-character display, the drive needs cleaning.• If the light flashes twice per second, the tape drive is updating firmware. For more information, see “Updating the Firmware” on page 45.• If the light flashes once per second, the tape drive is updating firmware. For more information, see “Updating the Firmware” on page 45.• If the light flashes twice per second, the tape drive detected an error and is performing a firmware recovery. It resets automatically.

Unload Button

The unload button (**2** in Figure 9 on page 31) enables you to perform the following functions:

- Rewind the tape into the cartridge and eject the cartridge from the tape drive. For more information, see “Removing a Tape Cartridge” on page 35.
- Enter or exit maintenance mode, or perform diagnostic or maintenance functions. For more information, see “Selecting a Diagnostic or Maintenance Function” on page 36.
- Perform a panic reset of the drive. **Attention:** If the tape drive detected a permanent error and displayed an error code, it automatically forces a drive dump (also known as a save of the firmware trace). If you perform a panic reset of the drive, the existing dump will be overwritten and lost. To perform a panic reset, press and hold the unload button on the drive for 10 seconds. The drive forces a dump and overwrites the existing dump. The drive then reboots to allow communication.

Single-Character Display

The Ultrium 2 Tape Drive features an LED (**3** in Figure 9 on page 31) that presents a single-character code for:

- Diagnostic or maintenance functions
- Error conditions and informational messages

Table 9 on page 36 lists each single-character code that is used for diagnostic or maintenance functions. Table 15 on page 67 lists the codes for error conditions and informational messages. If multiple errors occur, the code with the highest priority (represented by the lowest number) displays first. When the error is corrected, the code with the next highest priority displays, and so on until no errors remain.

Single Red Dot

The single-character display is blank during normal operation. However, if a drive dump is present while the drive is in maintenance mode, a single red dot illuminates on the display. To copy the dump to tape, see Function Code 5 in Table 9 on page 36.

The red dot turns off when you obtain the dump (by using an FMR tape a SCSI command, or a library command). If no dump is present while the drive is in maintenance mode, the single red dot does not illuminate.

Inserting a Tape Cartridge

To insert a tape cartridge:

1. Ensure that the Ultrium 2 Tape Drive is powered-on.
2. Ensure that the write-protect switch is properly set (see “Setting the Write-Protect Switch” on page 50).
3. Grasp the cartridge so that the write-protect switch faces you (see **1** in Figure 10).
4. Slide the cartridge into the tape load compartment.

Notes:

- a. If the cartridge is already in an ejected position and you want to reinsert it, remove the cartridge then insert it again.
- b. If the cartridge is already loaded and you cycle the power (turn it off, then on), the tape will reload.

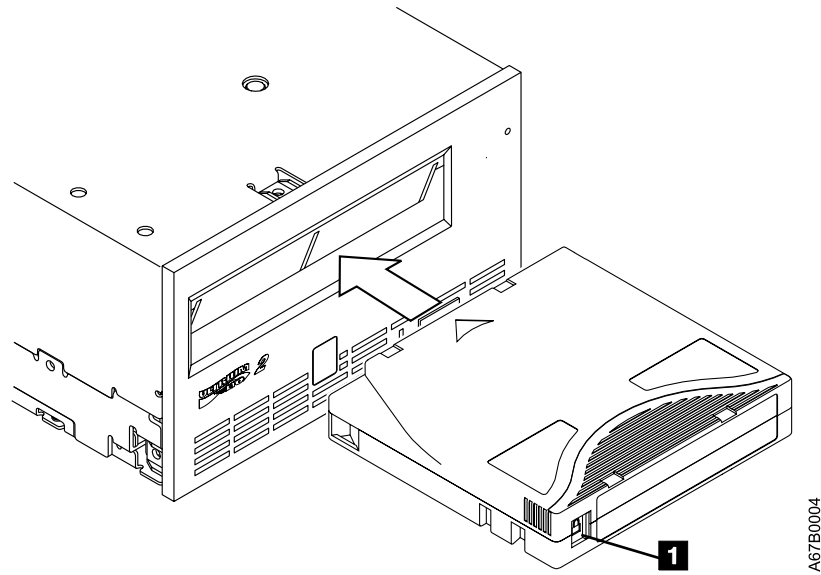

Figure 10. Inserting a cartridge into the Ultrium 2 Tape Drive

A67B0004

Removing a Tape Cartridge

To remove a tape cartridge:

1. Ensure that the Ultrium 2 Tape Drive is powered-on.
2. Press the unload button. The drive rewinds the tape and partially ejects the cartridge. The status light flashes green while the tape rewinds, then goes out before the cartridge partially ejects.
3. After the cartridge partially ejects, grasp the cartridge and remove it.

If you are unable to remove the cartridge, see “Manually Removing a Tape Cartridge” on page 85. Whenever you unload a tape cartridge, the tape drive writes any pertinent information to the cartridge memory.

Cleaning the Drive Head

Attention: To clean the drive head, use the IBM LTO Ultrium Cleaning Cartridge, the IBM TotalStorage Cleaning Cartridge (Ultrium LTO 2), or an IBM-approved cleaning cartridge.

Clean the drive head whenever **C** displays on the single-character display and the status light is flashing amber. To clean the head, insert the cleaning cartridge into the tape load compartment (see Figure 10 on page 34). The drive performs the cleaning automatically. When the cleaning is finished, the drive ejects the cartridge. The IBM TotalStorage Cleaning Cartridge (Ultrium LTO 2), the IBM LTO Ultrium Cleaning Cartridge, and most universal cleaning cartridges are generally valid for 50 cleanings.

Selecting a Diagnostic or Maintenance Function

The Ultrium 2 Tape Drive can run diagnostics, test write and read functions, test a suspect tape cartridge, update its own firmware, and perform other diagnostic and maintenance functions. The drive must be in maintenance mode to perform these functions. To place the drive in maintenance mode and select a diagnostic or maintenance function, see Table 9.

Attention: Maintenance functions cannot be performed concurrently with read or write operations. While in maintenance mode, the tape drive does not accept SCSI or Fibre Channel commands from the server. The tape drive does accept LDI or RS-422 commands.

Table 9. Diagnostic and maintenance functions

Function Code 1 - Run SCSI or Fibre Channel Tape Drive Diagnostics
Causes the tape drive to run self tests.
Attention: Insert only a scratch data cartridge for this test. Data on the cartridge will be overwritten.
<ol style="list-style-type: none">1. Make sure that no cartridge is in the drive.2. Within a 1.5-second interval, press the unload button three times. The status light becomes solid amber, which means that the drive is in maintenance mode.3. Press the unload button once per 1.5 seconds until 1 appears in the single-character display. If you cycle past 1, continue to press the unload button until it redisplay.4. To select the function, press and hold the unload button for 3 seconds. After you select the function, 1 flashes, the drive runs diagnostics for approximately 90 seconds, then C flashes. When C flashes, the drive is waiting for a cartridge.5. Within 60 seconds, insert a scratch data cartridge (or the tape drive exits maintenance mode). After you insert the cartridge, 1 flashes:<ul style="list-style-type: none">• If the diagnostic completes successfully, it begins again and runs for a maximum of 10 times. Each loop takes approximately 20 minutes to run. After the tenth loop, the diagnostic stops and automatically exits maintenance mode. To halt the diagnostic, press the unload button within the first 20 minutes of the test (or the diagnostic will run another 20 minutes). The drive acknowledges the request by slowing the length of time that the currently displayed character flashes on the single-character display (from twice per second to once per second). The diagnostic continues to the end of its loop and then stops. The tape drive then displays 0, rewinds and unloads the cartridge, and exits maintenance mode.• If the diagnostics fail, the status light flashes amber and an error code displays. The tape drive unloads the tape cartridge and exits maintenance mode. To resolve the error, locate the code in Table 15 on page 67.

Table 9. Diagnostic and maintenance functions (continued)

<p>Function Code 2 - Update Tape Drive Firmware from FMR Tape</p> <p>Causes the tape drive to load updated firmware from a field microcode replacement (FMR) tape.</p> <p>Attention: Do not power-off the tape drive while loading code.</p> <ol style="list-style-type: none">1. Make sure that no cartridge is in the drive.2. Within a 1.5-second interval, press the unload button three times. The status light becomes solid amber, which means that the drive is in maintenance mode.3. Press the unload button once per 1.5 seconds until 2 appears in the single-character display. If you cycle past 2, continue to press the unload button until it redisplay.4. To select the function, press and hold the unload button for 3 seconds. After you select the function, C flashes. When C flashes, the drive is waiting for a cartridge. Within 60 seconds, insert the FMR tape cartridge (or the tape drive exits maintenance mode). After you insert the cartridge, 2 flashes and the tape drive loads the updated firmware from the FMR tape cartridge into its erasable programmable read-only memory (EPROM) area:<ul style="list-style-type: none">• If the update completes successfully, the tape drive displays 0, rewinds and unloads the FMR tape, resets itself, and is ready to use the new firmware.• If the update fails, the tape drive posts an error code to the single-character display (to resolve the error, see Table 15 on page 67). The drive then unloads the FMR tape and exits maintenance mode.
<p>Function Code 3 - Create FMR Tape</p> <p>Causes the tape drive to copy its field microcode replacement (FMR) data to a scratch data cartridge.</p> <p>Attention: If you select this function, the tape drive will overwrite existing data on the scratch data cartridge.</p> <ol style="list-style-type: none">1. Make sure that no cartridge is in the drive.2. Within a 1.5-second interval, press the unload button three times. The status light becomes solid amber, which means that the drive is in maintenance mode.3. Press the unload button once per 1.5 seconds until 3 appears in the single-character display. If you cycle past 3, continue to press the unload button until it redisplay.4. To select the function, press and hold the unload button for 3 seconds. After you select the function, C flashes. When C flashes, the drive is waiting for a cartridge. Within 60 seconds, insert a scratch data cartridge that is not write protected (or the tape drive exits maintenance mode). After you insert the cartridge, 3 flashes and the tape drive copies the FMR data to the scratch data cartridge:<ul style="list-style-type: none">• If the tape drive creates the FMR tape successfully, it displays 0, rewinds and unloads the new FMR tape, and exits maintenance mode.• If the tape drive fails to create the FMR tape, it displays 7, unloads the FMR tape, and exits maintenance mode.

Table 9. Diagnostic and maintenance functions (continued)

<p>Function Code 4 - Force a Drive Dump</p> <p>Causes the tape drive to perform a collection (or <i>dump</i>) of data. (A drive dump is also known as a save of the firmware trace.) The dump (firmware trace) can only be analyzed by IBM.</p> <p>Note: When an error code displays, a red dot also displays to remind you that a dump already exists. If you perform Function Code 4, it will overwrite the dump and cause the error information to be lost.</p> <ol style="list-style-type: none">1. Make sure that no cartridge is in the drive.2. Within a 1.5-second interval, press the unload button three times. The status light becomes solid amber, which means that the drive is in maintenance mode.3. Press the unload button once per 1.5 seconds until 4 appears in the single-character display. If you cycle past 4, continue to press the unload button until it redisplay.4. To select the function, press and hold the unload button for 3 seconds. After you select the function, 4 displays, followed by 0. The single-character display then goes blank, and the tape drive exits maintenance mode. <p>An illuminated red dot on the single-character display indicates that a drive dump has been created. To retrieve the dump from the drive, see Function Code 5 on page 38.</p> <p>You can also perform this operation when the tape drive is in normal operating mode. Simply press and hold the unload button for 10 seconds.</p>
<p>Function Code 5 - Copy the Drive Dump to Tape (at Beginning of Tape)</p> <p>Causes the tape drive to copy data from a drive dump (captured with Function Code 4) to the beginning of a scratch data cartridge. An illuminated red dot on the single-character display indicates that a drive dump has been created.</p> <ol style="list-style-type: none">1. Make sure that no cartridge is in the drive.2. Within a 1.5-second interval, press the unload button three times. The status light becomes solid amber, which means that the drive is in maintenance mode.3. Press the unload button once per 1.5 seconds until 5 appears in the single-character display. If you cycle past 5, continue to press the unload button until it redisplay.4. To select the function, press and hold the unload button for 3 seconds. After you select the function, C flashes. When C flashes, the drive is waiting for a cartridge. Within 60 seconds, insert a scratch data cartridge that is not write-protected (or the tape drive exits maintenance mode). After you insert the cartridge, 5 flashes and the tape drive writes the dump data to the tape (at the beginning of the tape). When the function is complete, 0 displays, the drive rewinds and unloads the tape, and exits maintenance mode. <p>From the server, issue the SCSI READ command to read the dump from the tape to a file or electronic image. For information about where to send the electronic image, contact your OEM Product Application Engineer (PAE).</p>

Table 9. Diagnostic and maintenance functions (continued)

Function Code 6 - Run SCSI or Fibre Channel Wrap Test
<p>Causes the drive to perform one of the following:</p> <ul style="list-style-type: none">• A check of the SCSI circuitry from and to the SCSI connector• A check of the Fibre Channel circuitry from and to the Fibre Channel connector or fiber cable <p>To run the test, determine whether your drive uses a SCSI or Fibre Channel interface, then choose one of the following procedures.</p> <p>Running a SCSI Wrap Test</p> <p>This test evaluates the SCSI circuitry. A SCSI LVD wrap plug, a SCSI LVD terminator, and a Y-cable are required for this procedure.</p> <p>Note: You can terminate the Generation 1 drive internally while running the SCSI wrap test. Internal termination is not built into the Generation 2 drive, therefore you must run the SCSI wrap test by using a Y-cable and external termination.</p> <p>Before you select this function, you must configure the drive to supply term power, terminate the SCSI bus, and attach the SCSI wrap plug. Configure the drive to supply term power by placing a jumper on pin 6 of the drive's SCSI ID connector (as shown by the shaded area in the figure below).</p> <div style="text-align: center;"><p>A diagram of a SCSI ID connector, which is a 2x5 pin header. The top row contains pins 1 through 5, and the bottom row contains pins 6 through 10. Pin 6 is shaded. The diagram is labeled 'A67E0049' on the right side.</p></div> <p>Connect a Y-cable to the drive's SCSI connector. Place a terminator on one end of the Y-cable and the wrap plug on the other end.</p> <ol style="list-style-type: none">1. Ensure that the drive does not contain a cartridge.2. Within a 1.5-second interval, press the unload button three times. The status light becomes solid amber, which means that the drive is in maintenance mode.3. Press the unload button once per 1.5 seconds until 6 appears in the single-character display. If you cycle past 6, continue to press the unload button until it redisplay.4. To select the function, press and hold the unload button for 3 seconds. After you select the function, the tape drive automatically starts the test:<ul style="list-style-type: none">• If the test is successful, it loops and begins again. To halt the test, press the unload button. The drive acknowledges the request by slowing the length of time that the currently displayed character flashes on the single-character display (from twice per second to once per second). The test continues to the end of its loop, then stops. 0 displays and the drive exits maintenance mode. To continue to isolate the problem, go to "Fixing SCSI Bus Errors" on page 77 and locate the steps to take after you run the SCSI wrap test.• If the test fails, 8 displays, the test stops, and the tape drive exits maintenance mode. To resolve the error, replace the tape drive (see "Removing a SCSI Tape Drive from an Enclosure" on page 83).

Table 9. Diagnostic and maintenance functions (continued)

Running a Fibre Channel Wrap Test

This test evaluates the Fibre Channel circuitry at the drive's Fibre Channel connector, then at the fiber cable. A Fibre Channel wrap plug is required for this procedure. To run the wrap test through the fiber cable, a duplex adapter is required.

All cables and wrap plugs are hot-pluggable (that is, they can be removed from or added to the drive while the drive or its enclosure is powered-on). Do not bend the fiber cable more than a radius of 50.8 mm (2 in.) or the optical fiber may break.

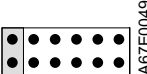
1. Take all devices on the Fibre Channel offline (for instructions, refer to your server's documentation).
2. Make sure that no cartridge is in the drive.
3. Disconnect the fiber cable from the drive and replace it with the Fibre Channel wrap plug. (When you disconnect the cable, the connection to the Fibre Channel loop may break, but will be restored at the end of the procedure when you reconnect the cable. For other devices on the loop, operations may temporarily be disrupted.)

Attention: Do not run the wrap test while the drive is connected to a Fibre Channel loop. This could disturb the Fibre Channel loop and cause performance or I/O problems.

4. Within a 1.5-second interval, press the unload button three times. The status light becomes solid amber, which means that the drive is in maintenance mode.
Note: If a cartridge is in the drive, it will eject the first time that you press the unload button and the drive will not be placed in maintenance mode. To continue placing the drive in maintenance mode, remove the cartridge and repeat this step.
5. Press the unload button once per 1.5 seconds until **6** appears in the single-character display.
Note: If you cycle past **6**, press the unload button once per second until it redisplay.

Testing the Circuitry at the Drive's Fibre Channel Connector

6. To select the function, press and hold the unload button for 3 seconds. After you select the function, the tape drive automatically starts the test:
 - If the test is successful, the circuitry at the drive's Fibre Channel connector is working properly. The test loops and begins again. Press the unload button. **0** displays and the tape drive exits maintenance mode. Continue to step 7 to test the fiber cable.
 - If the test fails, an error code displays and the status light flashes amber. The test stops and the drive exits maintenance mode. To resolve the error, locate the code in Table 15 on page 67.
7. Disconnect the Fibre Channel wrap plug from the drive.

Testing the Circuitry at the Fiber Cable

8. Connect the duplex adapter, then the Fibre Channel wrap plug to the end of the fiber cable.
Note: The Fibre Channel wrap test can only be run on cable lengths up to 250 meters (820 ft).
9. Within a 1.5-second interval, press the unload button three times. The status light becomes solid amber, which means that the drive is in maintenance mode.
Note: If a cartridge is in the drive, it will eject the first time that you press the unload button and the drive will not be placed in maintenance mode. To continue placing the drive in maintenance mode, remove the cartridge and repeat this step.
10. Press the unload button once per 1.5 seconds until **6** appears in the single-character display.
Note: If you cycle past **6**, press the unload button once per second until it redisplay.
11. To select the function, press and hold the unload button for 3 seconds. After you select the function, the tape drive automatically starts the test:
 - If the test is successful, the drive and the cable are working properly. The problem is at the server. To resolve the error, refer to the service guide for the server.
 - If the test fails, replace the fiber cable.
12. Remove the Fibre Channel wrap plug and the duplex adapter, and reconnect the fiber cable.

Table 9. Diagnostic and maintenance functions (continued)

<p>Function Code 7 - Run LDI or RS-422 Wrap Test</p> <p>Causes the tape drive to perform a check of the circuitry from and to the LDI or RS-422 connector.</p> <p>Before you select this function, attach an LDI or RS-422 wrap plug to the tape drive's LDI or RS-422 connector (in place of the LDI or RS-422 cable).</p> <ol style="list-style-type: none">1. Make sure that no cartridge is in the drive.2. Within a 1.5-second interval, press the unload button three times. The status light becomes solid amber, which means that the drive is in maintenance mode.3. Press the unload button once per 1.5 seconds until 7 appears in the single-character display. If you cycle past 7, continue to press the unload button until it redisplay.4. To select the function, press and hold the unload button for 3 seconds. After you select the function, 7 flashes and the tape drive automatically starts the test:<ul style="list-style-type: none">• If the test is successful, it loops and begins again. To halt the test, press the unload button. The test continues to the end of its loop and then stops. The tape drive then displays 0 and exits maintenance mode.• If the test fails, 9 displays, the test stops, and the tape drive exits maintenance mode. To resolve the error, locate 9 in Table 15 on page 67.
<p>Function Code 8 - Convert FMR Tape to Scratch Tape</p> <p>Causes the tape drive to erase the field microcode replacement (FMR) data on a scratch data cartridge and rewrite the cartridge memory on the tape. This turns the cartridge into a valid scratch data cartridge.</p> <ol style="list-style-type: none">1. Make sure that no cartridge is in the drive.2. Within a 1.5-second interval, press the unload button three times. The status light becomes solid amber, which means that the drive is in maintenance mode.3. Press the unload button once per 1.5 seconds until 8 appears in the single-character display. If you cycle past 8, continue to press the unload button until it redisplay.4. To select the function, press and hold the unload button for 3 seconds. After you select the function, C flashes. When C flashes, the drive is waiting for a cartridge. Within 60 seconds, insert the FMR cartridge (or the tape drive exits maintenance mode). After you insert the cartridge, 8 flashes, the tape drive erases the firmware on the tape, then rewrites the header in the cartridge memory to change the cartridge to a valid scratch data cartridge:<ul style="list-style-type: none">• If the operation is successful, the tape drive displays 0, rewinds and ejects the newly converted scratch data cartridge, and exits maintenance mode.• If the operation is not successful, an error code displays. To resolve the error, locate the code in Table 15 on page 67.

Table 9. Diagnostic and maintenance functions (continued)

Function Code 9 - Display Error Code Log
Causes the tape drive to display the last 10 error codes, one at a time (the codes are ordered; the most recent is presented first and the oldest (tenth) is presented last). <ol style="list-style-type: none">1. Make sure that no cartridge is in the drive.2. Within a 1.5-second interval, press the unload button three times. The status light becomes solid amber, which means that the drive is in maintenance mode.3. Press the unload button once per 1.5 seconds until 9 appears in the single-character display. If you cycle past 9, continue to press the unload button until it redisplay.4. To select the function, press and hold the unload button for 3 seconds. After you select the function, press the unload button to view the most recent error code. Press the unload button again to view successive error codes. If you press the unload button for 3 seconds after the tenth error code displays, 0 displays (if there are no errors in the log) and the drive exits maintenance mode.
Function Code A - Clear Error Code Log
Causes the tape drive to erase the contents of the error code log. <ol style="list-style-type: none">1. Make sure that no cartridge is in the drive.2. Within a 1.5-second interval, press the unload button three times. The status light becomes solid amber, which means that the drive is in maintenance mode.3. Press the unload button once per 1.5 seconds until A appears in the single-character display. If you cycle past A, continue to press the unload button until it redisplay.4. To select the function, press and hold the unload button for 3 seconds. After you select the function, the tape drive erases all errors from the error code log, displays 0, then exits maintenance mode.
Function Code C - Insert Cartridge into Tape Drive
This function cannot be selected by itself. It relates to other maintenance functions (such as Run Tape Drive Diagnostics or Create FMR Tape) that require an FMR tape cartridge or scratch tape cartridge that is not write protected.

Table 9. Diagnostic and maintenance functions (continued)

<p>Function Code E - Test Cartridge & Media</p> <p>Causes the tape drive to perform a Write/Read test (on the edge bands) to ensure that a suspect cartridge and its magnetic tape are acceptable. The tape drive takes approximately 10 minutes to run the test.</p> <p>Attention: Data on the suspect tape will be overwritten.</p> <ol style="list-style-type: none"> 1. Make sure that no cartridge is in the drive. 2. Within a 1.5-second interval, press the unload button three times. The status light becomes solid amber, which means that the drive is in maintenance mode. 3. Press the unload button once per 1.5 seconds until E appears in the single-character display. If you cycle past E, continue to press the unload button until it redisplay. 4. To select the function, press and hold the unload button for 3 seconds. After you select the function, C flashes. When C flashes, the drive is waiting for a cartridge. Within 60 seconds, insert the suspect data cartridge (or the tape drive exits maintenance mode). After you insert the cartridge, E flashes and the test begins: <ul style="list-style-type: none"> • If no error is detected, the test begins again and runs for a maximum of 10 times. After the tenth loop, the test stops and the drive automatically exits maintenance mode. To halt the test, press the unload button. The drive acknowledges the request by slowing the length of time that the currently displayed character flashes on the single-character display (from twice per second to once per second). The test continues to the end of its loop and then stops. The tape drive then rewinds and unloads the cartridge, displays 0, and exits maintenance mode. • If an error is detected, the tape drive displays 7, unloads the tape cartridge, and exits maintenance mode. To resolve the error, locate 7 in Table 15 on page 67.
<p>Function Code F - Fast Read/Write Test</p> <p>Causes the tape drive to perform tests to ensure that the drive can read from and write to tape. This diagnostic performs fewer tests than the Run Tape Drive Diagnostics test (Function Code 1). The tape drive takes approximately three minutes to run the test. The Fast Read/Write Test is not as comprehensive a test and is not recommended for isolating errors between the drive and the media.</p> <p>Attention: Data on the suspect tape will be overwritten.</p> <ol style="list-style-type: none"> 1. Make sure that no cartridge is in the drive. 2. Within a 1.5-second interval, press the unload button three times. The status light becomes solid amber, which means that the drive is in maintenance mode. 3. Press the unload button once per 1.5 seconds until F appears in the single-character display. If you cycle past F, continue to press the unload button until it redisplay. 4. To select the function, press and hold the unload button for 3 seconds. After you select the function, C flashes. When C flashes, the drive is waiting for a cartridge. Within 60 seconds, insert the suspect data cartridge (or the tape drive exits maintenance mode). After you insert the cartridge, F flashes and the test begins. <ul style="list-style-type: none"> • If no error is detected, the test begins again and runs for a maximum of 10 times. Each loop takes approximately 3 minutes to run. After the tenth loop, the test stops and the drive automatically exits maintenance mode. To halt the test, press the unload button. The drive acknowledges the request by slowing the length of time that the currently displayed character flashes on the single-character display (from twice per second to once per second). The test continues to the end of its loop and then stops. The tape drive then rewinds and unloads the cartridge, displays 0, and exits maintenance mode. • If an error is detected, the tape drive displays an error code, unloads the tape cartridge, and exits maintenance mode. To resolve the error, locate the code in Table 15 on page 67.

Table 9. Diagnostic and maintenance functions (continued)

<p>Function Code H - Test Head</p> <p>Causes the tape drive to perform the Head Resistance Measurements test and a Write/Read test (on the center of the tape). The drive runs these tests to ensure that the tape drive's head and tape-carriage mechanics are working correctly. The tape drive takes approximately 10 minutes to run the test.</p> <ol style="list-style-type: none"> 1. Make sure that no cartridge is in the drive. 2. Within a 1.5-second interval, press the unload button three times. The status light becomes solid amber, which means that the drive is in maintenance mode. 3. Press the unload button once per 1.5 seconds until H appears in the single-character display. If you cycle past H, continue to press the unload button until it redisplay. 4. To select the function, press and hold the unload button for 3 seconds. After you select the function, C flashes. When C flashes, the drive is waiting for a cartridge. Within 60 seconds, insert a scratch data cartridge (or the tape drive exits maintenance mode). After you insert the cartridge, H flashes and the test begins: <ul style="list-style-type: none"> • If no error is detected, the test begins again and runs for a maximum of 10 times. Each loop takes approximately 10 minutes to run. After the tenth loop, the test stops and the drive automatically exits maintenance mode. To halt the test, press the unload button. The drive acknowledges the request by slowing the length of time that the currently displayed character flashes on the single-character display (from twice per second to once per second). The test continues to the end of its loop and then stops. The tape drive then rewinds and unloads the cartridge, displays 0, and exits maintenance mode. • If an error is detected, the tape drive displays 5, unloads the tape cartridge, and exits maintenance mode. To resolve the error, locate 5 in Table 15 on page 67.
<p>Function Code L - Reserved for Future Use</p> <p>Reserved for future use.</p>
<p>Function Code P or U - Enable or Disable Post Error Reporting</p> <p>Used by support personnel during error detection, this function is an alternate method of setting or preventing the post error (PER) bit in the SCSI Read-Write Error Recovery Page. For more information, refer to the MODE SENSE command in the <i>IBM TotalStorage LTO Ultrium Tape Drive SCSI Reference</i>.</p> <ol style="list-style-type: none"> 1. Make sure that no cartridge is in the drive. 2. Within a 1.5-second interval, press the unload button three times. The status light becomes solid amber, which means that the drive is in maintenance mode. 3. Perform one of the following: <ul style="list-style-type: none"> • To enable post error reporting, press the unload button once per 1.5 seconds until U appears in the single-character display. If you cycle past U, continue to press the unload button until it redisplay. • To disable post error reporting, press the unload button once per 1.5 seconds until P appears in the single-character display. If you cycle past P, continue to press the unload button until it redisplay. 4. To select the function, press and hold the unload button for 3 seconds. After you select the function, the drive displays one of the following: <ul style="list-style-type: none"> • P to indicate that post error reporting is enabled. • U to indicate that post error reporting is disabled.

Exiting Maintenance Mode

To manually exit maintenance mode, press the unload button once per second until 0 appears on the single-character display. Press and hold the unload button for 3 seconds. The drive exits maintenance mode (the solid amber status light becomes solid green, then turns off).

You can also exit maintenance mode by pressing the unload button during any maintenance or diagnostic function.

Updating the Firmware

Attention: When updating firmware, do not power-off the tape drive until the update is complete, or the firmware may be lost.

Periodically check for updated levels of drive firmware by visiting the web at <http://www.ibm.com/storage/1to>. You can update your drive's firmware by:

- Obtaining the new firmware image and downloading it to the drive through the SCSI or Fibre Channel interface
- Obtaining the new firmware image and downloading it to the drive through the LDI or RS-422 interface
- Loading the firmware from a field microcode replacement (FMR) tape cartridge

For instructions about how to obtain a new firmware image or FMR tape, visit the preceding web site. To update the firmware, refer to the following sections.

Updating Firmware through the SCSI or Fibre Channel Interface

Attention: SCSI drives and Fibre Channel drives require different firmware images.

When you update the tape drive's firmware by using the SCSI or Fibre Channel interface, the procedure varies, depending on whether your server uses an IBM tape device driver or a non-IBM tape device driver (such as a driver from Sun, Hewlett-Packard, or Microsoft).

For instructions about updating firmware from a server that uses an IBM tape device driver, refer to the *IBM Ultrium Device Drivers Installation and User's Guide*.

To update firmware from a server that uses a non-IBM tape device driver, refer to the documentation for that device driver.

Updating Firmware through the Library/Drive Interface

The Ultrium 2 Tape Drive includes a firmware update feature that allows a tape library to download firmware to the drive by using the Library/Drive Interface (LDI) while the drive performs normal host operations on logical unit number (LUN) 0 of the SCSI Protocol Interface. The update typically takes 63 seconds and a maximum of 140 seconds. To activate the new firmware, cycle power to the drive, or unload the drive and issue a Power-on Reset command. The command may be received by the SCSI interface or the LDI (RS-422) interface.

Note: If a Power-on Reset command is received while a cartridge is loaded in the drive, the drive will respond with a Check Condition. It will not activate the new code level until you cycle power, or until you receive a Power-on Reset command when the drive does not contain a cartridge.

Updating the Firmware with an FMR Tape Cartridge

Attention: SCSI drives and Fibre Channel drives require different firmware images.

To update the Ultrium 2 Tape Drive's firmware from an FMR tape cartridge:

1. Ensure that the tape drive is unloaded.
2. Place the drive in maintenance mode by pressing the unload button three times within a 1.5-second interval. The status light becomes solid amber, which means that the drive is in maintenance mode.
3. Press the unload button once per 1.5 seconds until **2** displays, then press and hold the button for 3 seconds. When **C** flashes, the drive is waiting for a cartridge.
4. Insert the FMR tape cartridge. **2** flashes, the drive loads the updated firmware from the cartridge, and the status light flashes amber. When the update completes successfully, **0** displays and the cartridge automatically ejects.

The drive resets itself and automatically activates the new firmware.

If the update fails, an error code displays. To resolve the error, locate the code in Table 15 on page 67.

Chapter 5. Using the Media

The IBM TotalStorage LTO Ultrium 2 Tape Drive uses the following cartridge types:

- IBM TotalStorage LTO Ultrium 200 GB Data Cartridge (Generation 2)
- IBM LTO Ultrium Cleaning Cartridge
- IBM TotalStorage Cleaning Cartridge (Ultrium LTO 2)

The Ultrium 2 Tape Drive (Generation 2) is compatible with the cartridges of its predecessor, the IBM Ultrium Internal Tape Drive (Generation 1). Cartridge compatibility for the Ultrium 2 Tape Drive is as follows:

- Reads and writes Generation 2 cartridges to Generation 2 format
- Reads and writes Generation 1 cartridges to Generation 1 format
- Does not write Generation 2 cartridges to Generation 1 format
- Does not write Generation 1 cartridges to Generation 2 format

Figure 11 shows the IBM TotalStorage LTO Ultrium 200 GB Data Cartridge and its components.

- | | | | |
|----------|----------------------|----------|----------------------|
| 1 | LTO cartridge memory | 4 | Write-protect switch |
| 2 | Cartridge door | 5 | Label area |
| 3 | Leader pin | 6 | Insertion guide |

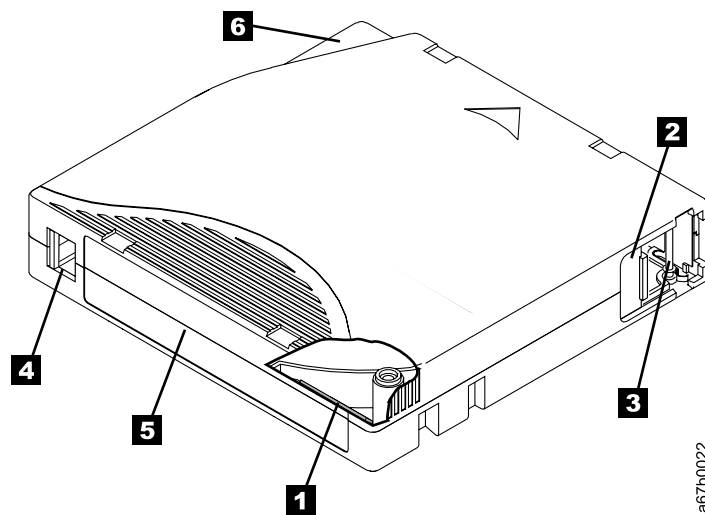

Figure 11. The IBM TotalStorage LTO Ultrium 200 GB Data Cartridge

In addition to using LTO Ultrium 2 Tape Cartridges with up to 200 GB capacity, the tape drive reads and writes to certified LTO Ultrium Tape Cartridges that have capacities of 100, 50, 30, and 10 GB. If you want to control the capacity of the cartridge (for example, if you want to limit the capacity to obtain a faster seek time) you can do so by issuing the SCSI command SET CAPACITY. For information about this command, refer to the *IBM TotalStorage LTO Ultrium Tape Drive SCSI Reference*.

To ensure that your tape drive conforms to IBM's specifications for reliability, use only IBM TotalStorage LTO Ultrium Tape Cartridges. You may use other LTO-certified data cartridges, but they may not meet the standards of reliability that are established by IBM. The IBM TotalStorage LTO Ultrium 200 GB Data Cartridge cannot be interchanged with the media used in other IBM non-LTO Ultrium tape products.

Data Cartridge

The IBM TotalStorage LTO Ultrium 200 GB Data Cartridge contains 1/2-inch, dual-coat, metal-particle tape that has a native data capacity of 200 GB (400 GB at 2:1 compression). When processing the tape, the IBM TotalStorage LTO Ultrium 2 Tape Drive uses a linear, serpentine recording format, and reads and writes data on 512 tracks, eight tracks at a time. The first set of eight tracks is written from near the beginning of the tape to near the end of the tape. The head then repositions to the next set of eight tracks for the return pass. This process continues until all tracks are written and the tape is full, or until all data is written.

The IBM TotalStorage LTO Ultrium 200 GB Data Cartridge includes a Linear Tape-Open Cartridge Memory (LTO-CM) chip (**1** in Figure 11 on page 47), that contains information about the cartridge and the tape (such as the name of the manufacturer that created the tape), as well as statistical information about the cartridge's use. Whenever you unload a tape cartridge, the tape drive writes any pertinent information to the cartridge memory. The storage capacity of the LTO-CM is 4096 bytes.

The cartridge door **2** protects the tape from contamination when the cartridge is out of the drive. Behind the door, the tape is attached to a leader pin **3**. When you insert the cartridge into the drive, a threading mechanism pulls the pin (and tape) out of the cartridge, across the drive head, and onto a non-removable takeup reel. The head can then read or write data from or to the tape.

The write-protect switch **4** prevents data from being written to the tape cartridge. The label area **5** provides a location for you to place a label. Affix only a bar code label. When affixing a label, place it only in the recessed label area. A label that extends outside of the recessed area can cause loading problems in the drive. The insertion guide **6** is a large, notched area that prevents you from inserting the cartridge incorrectly.

You can order tape cartridges with the bar code labels included, or you can order custom labels. To obtain tape cartridges and bar code labels, see "Ordering Media Supplies" on page 63.

The IBM TotalStorage LTO Ultrium 200 GB Data Cartridge has a nominal cartridge life of 5000 load and unload cycles. The Generation 2 cartridge is purple; the Generation 1 cartridge is black.

Cleaning Cartridges

The Ultrium 2 Tape Drive is compatible with the IBM LTO Ultrium Cleaning Cartridge (part number 08L9124) and the IBM TotalStorage Cleaning Cartridge (Ultrium LTO 2) (part number 35L2086).

The IBM TotalStorage Cleaning Cartridge functions with Ultrium-format tape drives that are produced by compliance-verified manufacturers. The cartridge lets you buy and use a single cleaning cartridge for all of your tape drives, rather than spend time and money to support several different cleaning cartridges.

The IBM TotalStorage Cleaning Cartridge (Ultrium LTO 2) is downward-compatible with the Ultrium Internal Tape Drive (Generation 1). To enable your Generation 1 drive to use the cartridge, simply download and install the latest drive firmware (for instructions, see “Updating the Firmware” on page 45).

The drive itself determines when a head needs to be cleaned. It alerts you by displaying **C** on the single-character display and causing the status light to become flashing amber. To clean the head, insert the cleaning cartridge into the tape load compartment (see Figure 10 on page 34). The tape drive performs the cleaning automatically. When the cleaning is finished, the drive ejects the cartridge.

To remove a cleaning cartridge, see “Unload Button” on page 33. The IBM TotalStorage Cleaning Cartridge (Ultrium LTO 2) and the IBM LTO Ultrium Cleaning Cartridge are valid for 50 uses (the cartridge’s LTO-CM chip tracks the number of times that the cartridge is used).

Setting the Write-Protect Switch

The position of the write-protect switch on the tape cartridge (see **1** in Figure 12) determines whether you can write to the tape:

- If the switch is set to  (solid red), data cannot be written to the tape.
- If the switch is set to unlocked (black void), data can be written to the tape.

To set the switch, slide it left or right to the desired position.

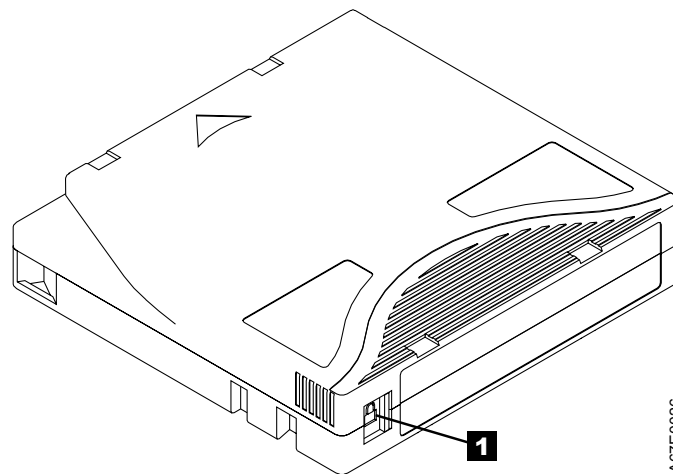

Figure 12. Setting the write-protect switch

Handling the Cartridges



Attention: Do not insert a damaged tape cartridge into your Ultrium 2 Tape Drive. A damaged cartridge can interfere with the reliability of the drive and may void the warranties of the drive and the cartridge. Before inserting a tape cartridge, inspect the cartridge case, cartridge door, and write-protect switch for breaks. If you need to recover data from a damaged cartridge, contact your OEM Product Application Engineer (PAE).

Incorrect handling or an incorrect environment can damage the LTO Ultrium Tape Cartridge or its magnetic tape. To avoid damage to your tape cartridges and to ensure the continued high reliability of your IBM TotalStorage LTO Ultrium 2 Tape Drive, use the following guidelines.

Provide Training

- Post procedures that describe proper media handling in places where people gather.
- Ensure that anyone who handles tape has been properly trained in handling and shipping procedures. This includes operators, users, programmers, archival services, and shipping personnel.
- Ensure that any service or contract personnel who perform archiving are properly trained in media-handling procedures.
- Include media-handling procedures as part of any services contract.
- Define and make personnel aware of data recovery procedures.

Ensure Proper Packaging

- When you ship a cartridge, ship it in its original or better packaging.
- Always ship or store a cartridge in a jewel case.
- Use only a recommended shipping container that securely holds the cartridge in its jewel case during transportation. Ultrium Turtlecases (by Perm-A-Store) have been tested and found to be satisfactory (see Figure 13). They are available at www.turtlecase.com.



Figure 13. Tape cartridges in a Turtlecase

- Never ship a cartridge in a commercial shipping envelope. Always place it in a box or package.
- If you ship the cartridge in a cardboard box or a box of a sturdy material, ensure the following:
 - Place the cartridge in polyethylene plastic wrap or bags to protect it from dust, moisture, and other contaminants.
 - Pack the cartridge snugly; do not allow it to move around.
 - Double-box the cartridge (place it inside a box, then place that box inside the shipping box) and add padding between the two boxes (see Figure 14 on page 52).



Figure 14. Double-boxing tape cartridges for shipping

Provide Proper Acclimation and Environmental Conditions

- Before you use a cartridge, let it acclimate to the normal operating environment for 1 hour. If you see condensation on the cartridge, wait an additional hour.
- Ensure that all surfaces of a cartridge are dry before inserting it.
- Do not expose the cartridge to moisture or direct sunlight.
- Do not expose recorded or blank cartridges to stray magnetic fields of greater than 100 oersteds (for example, terminals, motors, video equipment, X-ray equipment, or fields that exist near high-current cables or power supplies). Such exposure can cause the loss of recorded data or make the blank cartridge unusable.
- Maintain the conditions that are described in “Environmental and Shipping Specifications for Tape Cartridges” on page 62.

Perform a Thorough Inspection

After purchasing a cartridge and before using it, perform the following steps:

- Inspect the cartridge’s packaging to determine potential rough handling.
- When inspecting a cartridge, open only the cartridge door. Do not open any other part of the cartridge case. The upper and lower parts of the case are held together with screws; separating them destroys the usefulness of the cartridge.
- Inspect the cartridge for damage before using or storing it.
- Inspect the rear of the cartridge (the part that you load first into the tape load compartment) and ensure that there are no gaps in the seam of the cartridge case (see **4** in Figure 17 on page 56). If there are gaps in the seam (see Figure 15 on page 53), the leader pin may be dislodged. Go to “Repositioning or Reattaching a Leader Pin” on page 55.



Figure 15. Checking for gaps in the seams of a cartridge

- Check that the leader pin is properly seated.
- If you suspect that the cartridge has been mishandled but it appears useable, copy any data onto a good cartridge immediately for possible data recovery. Discard the mishandled cartridge.
- If you must recover data from a damaged cartridge, contact your service representative.
- Review handling and shipping procedures.

Handle the Cartridge Carefully

- Do not drop the cartridge. If the cartridge drops, slide the cartridge door back and ensure that the leader pin is properly seated in the pin-retaining spring clips (see **2** in Figure 16 on page 55). If the leader pin has become dislodged, go to “Repositioning or Reattaching a Leader Pin” on page 55.
- Do not handle tape that is outside the cartridge. Handling the tape can damage the tape’s surface or edges, which may interfere with read or write reliability. Pulling on tape that is outside the cartridge can damage the tape and the brake mechanism in the cartridge.
- Do not stack more than six cartridges.
- Do not degauss a cartridge that you intend to reuse. Degaussing makes the tape unusable.

Examples of Cartridge Problems

Example: Improper Placement of Leader Pin

The leader pin is misaligned. Perform the following steps:

1. Look for cartridge damage.
2. Use the IBM Leader Pin Reattachment Kit (part number 08L9129) to correctly seat the pin (see “Repositioning a Leader Pin” on page 55). Then, immediately use data recovery procedures to minimize chances of data loss.

Example: Split Cartridge Case

The cartridge’s case is damaged. There is a high possibility of media damage and potential loss. Perform the following steps:

1. Look for cartridge mishandling.
2. Use the IBM Leader Pin Reattachment Kit (part number 08L9129) to correctly seat the pin (see “Repositioning a Leader Pin” on page 55). Then, immediately use data recovery procedures to minimize chances of data loss.
3. Review media-handling procedures.

Repositioning or Reattaching a Leader Pin



Attention: Use a repaired tape cartridge only to recover data and move it to another cartridge. Continued use of a repaired cartridge may void the warranties of the drive and the cartridge.

If the leader pin in your cartridge becomes dislodged from its pin-retaining spring clips or detaches from the tape, you must use the IBM Leader Pin Reattachment Kit (part number 08L9129) to reposition or reattach it. (Do not reattach the pin if you must remove more than 7 meters (23 feet) of leader tape.) The sections that follow describe each procedure.

Repositioning a Leader Pin

A leader pin that is improperly seated inside a cartridge can interfere with the operation of the drive. Figure 16 shows a leader pin in the incorrect **1** and correct **2** positions.

To place the leader pin in its proper position, you will need the following tools:

- Plastic or blunt-end tweezers
- Cartridge manual rewind tool (from Leader Pin Reattachment Kit, part number 08L9129)

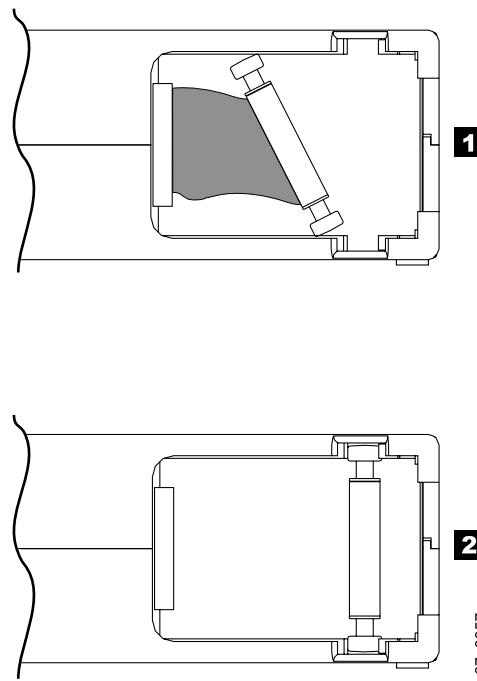

Figure 16. Leader pin in the incorrect and correct positions. The cartridge door is open and the leader pin is visible inside the cartridge.

To reposition the leader pin, perform the following steps.

1. Slide open the cartridge door (**1** in Figure 17) and locate the leader pin **2** (you may need to shake the cartridge gently to roll the pin toward the door).
2. With plastic or blunt-end tweezers, grasp the leader pin and position it in the pin-retaining spring clips **3** .
3. Press the leader pin gently into the clips until it snaps into place and is firmly seated. Ensure that there are no gaps in the seam of the cartridge **4** .
Attention: If gaps exist, do not continue with this procedure and do not use the cartridge. Instead, contact your OEM Product Application Engineer (PAE).
4. Close the cartridge door.

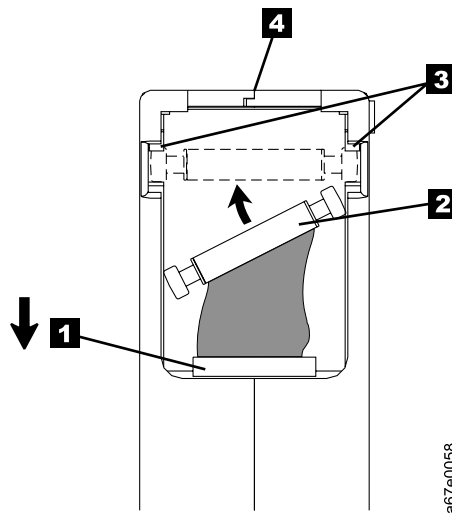

Figure 17. Placing the dislodged leader pin into the correct position. The cartridge door is open to show the leader pin.

5. To rewind the tape, insert the cartridge manual rewind tool (**1** in Figure 18) into the cartridge's hub **2** and turn it clockwise until the tape becomes taut.

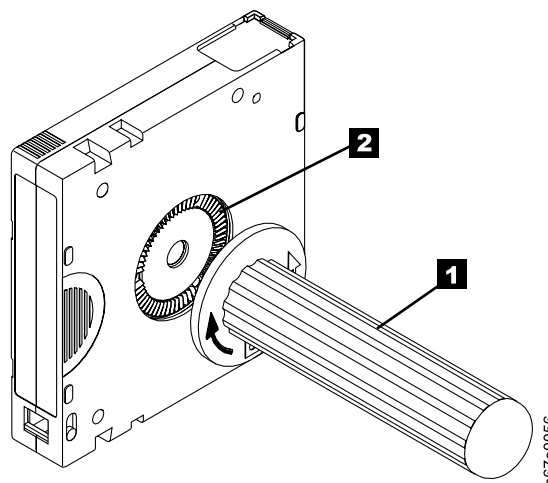

Figure 18. Rewinding the tape into the cartridge

6. Remove the rewind tool by pulling it away from the cartridge.

Reattaching a Leader Pin

The first meter of tape in a cartridge is leader tape. Once the leader tape has been removed there is a possibility of tape breakage. After reattaching the leader pin, transfer data from the defective tape cartridge. **Do not reuse the defective tape cartridge.**

The Leader Pin Reattachment Kit contains three parts:

- **Leader pin attach tool** (see **1** in Figure 19). A plastic brace that holds the cartridge door open.
- **Cartridge manual rewind tool** (see **2** in Figure 19). A device that fits into the cartridge's hub and lets you wind the tape into and out of the cartridge.
- **Pin supplies** (see **3** in Figure 19). Leader pins and C-clips.

Attention:

- Use only the IBM Leader Pin Reattachment Kit to reattach the leader pin to the tape. Other methods of reattaching the pin will damage the tape, the drive, or both.
- Use this procedure on your tape cartridge only when the leader pin detaches from the magnetic tape and you must copy the cartridge's data onto another cartridge. Destroy the damaged cartridge after you copy the data. This procedure may affect the performance of the leader pin during threading and unloading operations.
- Touch only the end of the tape. Touching the tape in an area other than the end can damage the tape's surface or edges, which may interfere with read or write reliability.

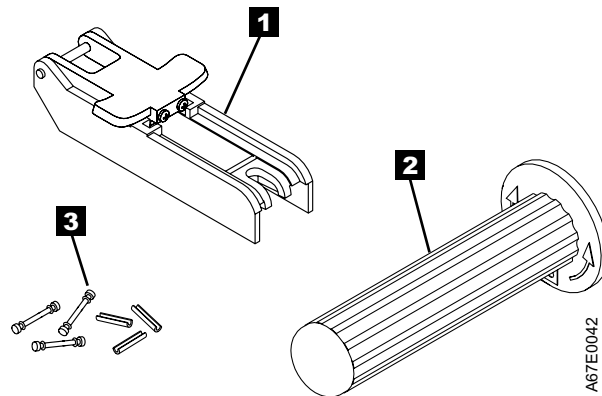
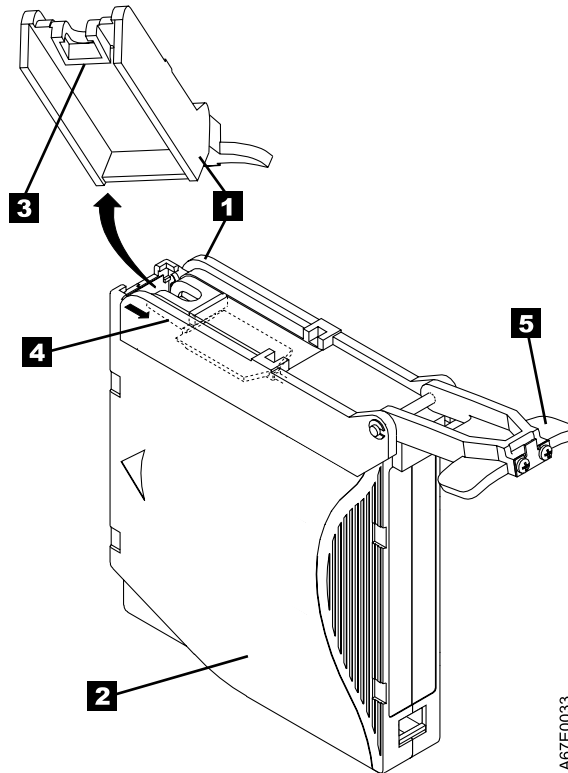

Figure 19. Leader Pin Reattachment Kit

The following procedure describes how to reattach a leader pin.

To reattach a leader pin by using the IBM Leader Pin Reattachment Kit:

1. Attach the leader pin attach tool (**1** in Figure 20) to the cartridge (**2**) so that the tool's hook (**3**) latches into the cartridge's door (**4**). Pull the tool back to hold the door open, then slide the tool onto the cartridge. Open the tool's pivot arm (**5**).



A67E0033

Figure 20. Attaching the leader pin attach tool to the cartridge. To hold the cartridge door open, hook the tool into the door and pull the tool back.

2. To find the end of the tape inside the cartridge, attach the cartridge manual rewind tool (**1** in Figure 21) to the cartridge's hub (**2**) by fitting the tool's teeth between the teeth of the hub. Turn the tool clockwise until you see the end of the tape inside the cartridge. Then, slowly turn the rewind tool counterclockwise to bring the tape edge toward the cartridge door (**3**).
3. Continue to turn the rewind tool counterclockwise until approximately 12.7 cm (5 in.) of tape hangs from the cartridge door. If necessary, grasp the tape and pull gently to unwind it from the cartridge.
4. Remove the rewind tool by pulling it away from the cartridge. Set the tool and the cartridge aside.

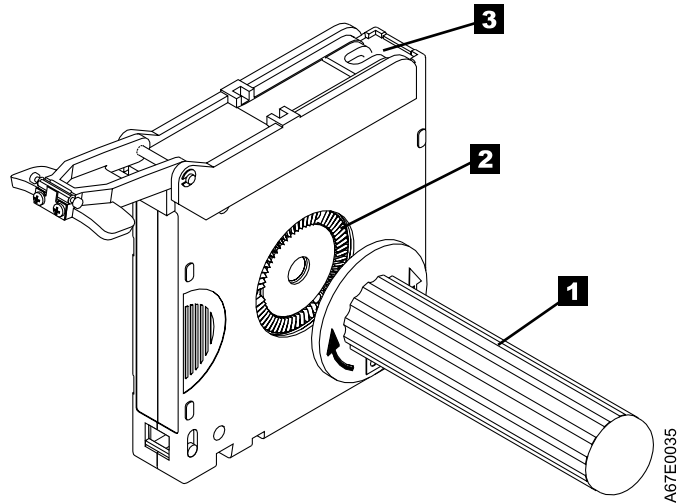

Figure 21. Winding the tape out of the cartridge. Turn the cartridge manual rewind tool clockwise to see the end of the tape, then turn it counterclockwise to bring the tape to the cartridge door.

5. On the leader pin (**1** in Figure 22), locate the open side of the C-clip (**2**). The C-clip is a small black part that secures the tape (**3**) to the pin.
6. Remove the C-clip from the leader pin by using your fingers to push the clip away from the pin. Set the pin aside and discard the clip.

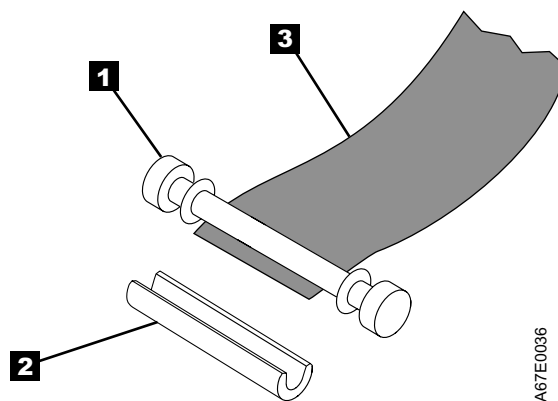

Figure 22. Removing the C-clip from the leader pin. Use your fingers to push the C-clip from the leader pin.

7. Position the tape in the alignment groove of the leader pin attach tool (see **1** in Figure 23).
8. Place a new C-clip into the retention groove **2** (Figure 23) on the leader pin attachment tool and make sure that the clip's open side faces up.
9. Place the leader pin (from step 6 on page 59) into the cavity **3** (Figure 23) of the leader pin attach tool.

Attention: To prevent the leader pin from rolling into the cartridge, in the following step use care when folding the tape over the pin.

10. Fold the tape over the leader pin and hold it with your fingers (see Figure 23).

Note: Use care to ensure that the tape is centered over the leader pin. Failure to properly center the tape on the pin will cause the repaired cartridge to fail. When the tape is properly centered, a 0.25-mm (0.01-in.) gap exists on both sides of the pin.

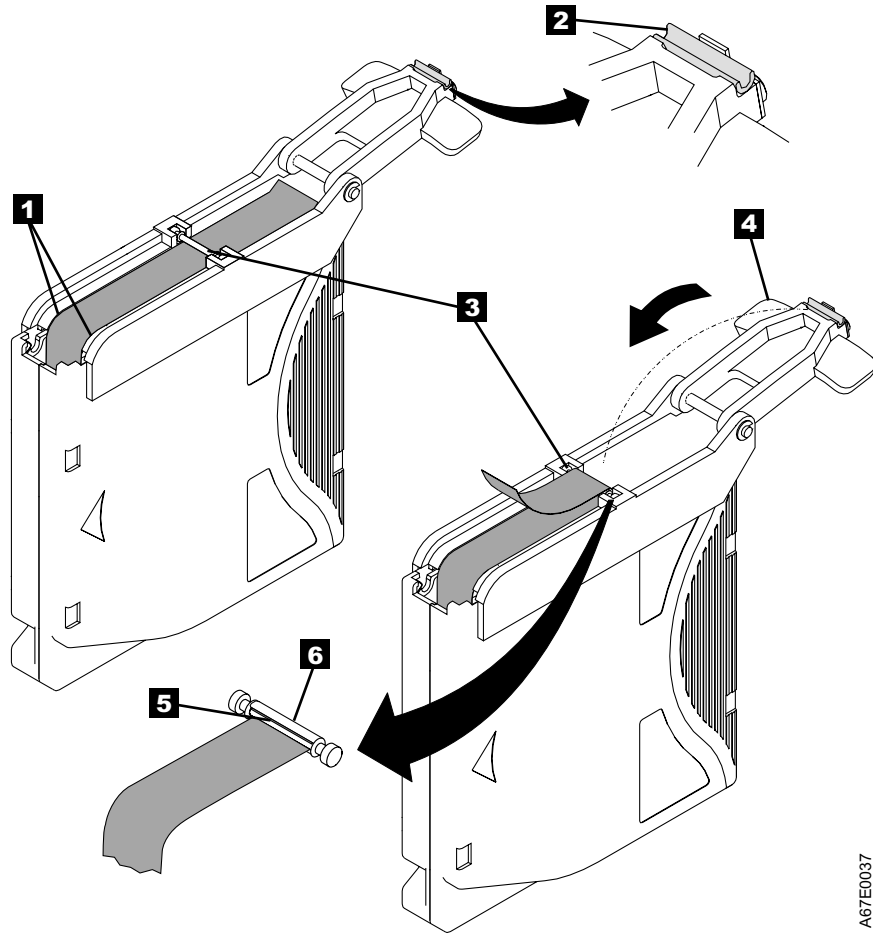

Figure 23. Attaching the leader pin to the tape

11. Close the pivot arm **4** of the leader pin attach tool by swinging it over the leader pin so that the C-clip snaps onto the pin and the tape.
12. Swing the pivot arm open and trim the excess tape **5** so that it is flush with the reattached leader pin **6**.

13. Use your fingers to remove the leader pin from the cavity **3** in the leader pin attach tool.
14. Use the cartridge manual rewind tool to wind the tape back into the cartridge (wind the tape clockwise). Ensure that the leader pin is latched by the pin-retaining spring clips on each end of the leader pin.
15. Remove the rewind tool.
16. Remove the leader pin attach tool by lifting its end up and away from the cartridge.



Attention: Use a repaired tape cartridge only to recover data and move it to another cartridge. Continued use of a repaired cartridge may void the warranties of the drive and the cartridge.

Environmental and Shipping Specifications for Tape Cartridges

Before you use a tape cartridge, acclimate it to the operating environment for 24 hours or the time necessary to prevent condensation in the drive (the time will vary, depending on the environmental extremes to which the drive was exposed).

The best storage container for the cartridges (until they are opened) is the original shipping container. The plastic wrapping prevents dirt from accumulating on the cartridges and partially protects them from humidity changes.

When you ship a cartridge, place it in its jewel case or in a sealed, moisture-proof bag to protect it from moisture, contaminants, and physical damage. Ship the cartridge in a shipping container that has enough packing material to cushion the cartridge and prevent it from moving within the container.

Table 10 gives the environment for operating, storing, and shipping LTO Ultrium Tape Cartridges.

Table 10. Environment for operating, storing, and shipping the LTO Ultrium Tape Cartridge

Environmental Specifications				
Environmental Factor	Operating	Operational Storage¹	Archival Storage²	Shipping
Temperature	10 to 45°C (50 to 113°F)	16 to 32°C (61 to 90°F)	16 to 25°C (61 to 77°F)	-23 to 49°C (-9 to 120°F)
Relative humidity (noncondensing)	10 to 80%	20 to 80%	20 to 50%	5 to 80%
Wet bulb temperature	26°C (79°F)	26°C (79°F)	26°C (79°F)	26°C (79°F)
Notes:				
1. Operational storage equals less than 1 year.				
2. Archival storage equals 1 to 10 years.				

Disposing of Tape Cartridges

Under the current rules of the U.S. Environmental Protection Agency (EPA), regulation 40CFR261, the LTO Ultrium Tape Cartridge is classified as non-hazardous waste. As such, it may be disposed of in the same way as normal office trash. These regulations are amended from time to time, and you should review them at the time of disposal.

If your local, state, country (non-U.S.A.), or regional regulations are more restrictive than EPA 40CFR261, you must review them before you dispose of a cartridge. Contact your account representative for information about the materials that are in the cartridge.

If a tape cartridge must be disposed of in a secure manner, you can erase the data on the cartridge by using a high-energy AC degausser (use a minimum of 1200 oersted peak field over the entire space that the cartridge occupies). Degaussing makes the cartridge unusable.

If you burn the cartridge and tape, ensure that the incineration complies with all applicable regulations.

Ordering Media Supplies

Table 11 lists the cartridges and media supplies that you can order for the IBM TotalStorage LTO Ultrium 2 Tape Drive. To order media supplies, visit the web at <http://www.ibm.com/storage/lto>.

Table 11. Media supplies for the IBM TotalStorage LTO Ultrium 2 Tape Drive

IBM Part Number	Product Description
08L9870	IBM TotalStorage LTO Ultrium 200 GB Data Cartridge (includes only human-writable labels)
19P5897	IBM TotalStorage LTO Ultrium 200 GB Data Cartridge Bar Code Labels, sheet of 20, black and white
08L9124	IBM LTO Ultrium Cleaning Cartridge (includes only human-writable labels)
35L2086	IBM TotalStorage Cleaning Cartridge (Ultrium LTO 2)
08L9267	IBM LTO Ultrium Cleaning Cartridge Bar Code Labels, sheet of 20, black and white

Ordering Custom Bar Code Labels

If custom bar code labels are required for your data or cleaning cartridges, order them directly from the authorized label suppliers in Table 12.

Table 12. Authorized suppliers of custom bar code labels

In America	In Europe and Asia
EDP/Colorflex 697 South Pierce Street Louisville, CO 80027 U. S. A. Telephone: 800-522-3528 http://www.colorflex.com/Ai/Home.asp	EDP Europe, Ltd. 43 Redhills Road South Woodham Ferrers Chelmsford, Essex CM3 5UL U. K. Telephone: 44 (0) 1245-322380 http://www.edpeurope.com/media_labelling.htm
Dataware (LTO 2 only) 7570 Renwick Houston, TX 77081 U. S. A. Telephone: 800-426-4844 http://www.datawarelabels.com/	Dataware Labels Europe Heubergstrasse 9 D-83052 Bruckmuhl-Gotting Germany Telephone: 49 806-29455 http://www.datawarelabels.com/
NetC P. O. Box 320784 Fairfield, CT 06432 U. S. A. Telephone: 203-372-6382 http://www.netc11c.com/	NetC Europe Ltd Town Farm Bungalow North Curry Taunton Somerset U. K. TA3 6LX Telephone: 44 (0) 1823 491439 http://www.netclabels.co.uk
	NetC Asia Pacific Pty Ltd Locked Bag 14 Kenthurst NSW Australia 2156 Telephone: 61 (0) 2 9654 8272 http://www.netclabels.com.au

Chapter 6. Resolving Problems

If you encounter problems when running the IBM TotalStorage LTO Ultrium 2 Tape Drive, refer to Table 13. If the problem is not identified in Table 13, refer to “Methods of Receiving Errors and Messages” on page 66. The color and condition of the status light may also indicate a problem. For more information, see “Status Light” on page 32.

Table 13. Troubleshooting tips for the IBM TotalStorage LTO Ultrium 2 Tape Drive

If the problem is this....	Do this....
A code displays on the single-character display and the status light flashes amber.	The tape drive detected an error or is directing you to an informational message. See Table 15 on page 67.
The status light or single-character display never turns on.	The tape drive has no power. Check the power at the power source. Connect power to the tape drive (see “Step 6. Connect and Test Power to the Tape Drive” on page 27). If the problem persists, replace the tape drive.
The tape drive will not load a tape cartridge.	<p>One of the following has occurred:</p> <ul style="list-style-type: none"> • A tape cartridge is already inserted. To remove the cartridge, press the unload button. If the cartridge does not eject, turn off the power to the tape drive, then turn it back on. After the status light becomes solid green, press the unload button to eject the cartridge. • The tape cartridge was inserted incorrectly. To properly insert a cartridge, see “Inserting a Tape Cartridge” on page 34. • The tape cartridge may be defective. Insert another tape cartridge. If the problem exists for multiple cartridges, the tape drive is defective. Replace the tape drive (see “Removing a SCSI Tape Drive from an Enclosure” on page 83 or “Removing a Fibre Channel Tape Drive from an Enclosure” on page 84). • The tape drive has no power. Connect power to the tape drive (see “Step 6. Connect and Test Power to the Tape Drive” on page 27).
The tape drive will not unload the tape cartridge.	The tape cartridge is stuck or is broken. Press the unload button. If the cartridge does not eject, turn off the power to the tape drive, then turn it back on (note that the mid-tape recovery could take up to 5 minutes to complete). If the cartridge still does not eject, manually remove it (see “Manually Removing a Tape Cartridge” on page 85).
The server received TapeAlert flags.	See Appendix B, “TapeAlert Flags” on page 97.
The server reported SCSI problems (such as selection or command time-outs, or parity errors).	See “Fixing SCSI Bus Errors” on page 77.
The server reported Fibre Channel problems.	See “Fixing Fibre Channel Errors” on page 79.
The Fibre Channel drive indicates no Fibre Channel light, or has light but cannot communicate.	See “Fixing Fibre Channel Errors” on page 79.
The library reported an LDI or RS-422 communication problem with the drive.	The LDI or RS-422 circuitry may be defective. Run the LDI or RS-422 wrap test (Function Code 7 in Table 9 on page 36). If the test runs successfully but the problem persists, refer to your library’s service documentation.
Codes display on the single-character display, but the status light does not turn on.	The tape drive is defective. Replace the tape drive (see “Removing a SCSI Tape Drive from an Enclosure” on page 83 or “Removing a Fibre Channel Tape Drive from an Enclosure” on page 84).

Table 13. Troubleshooting tips for the IBM TotalStorage LTO Ultrium 2 Tape Drive (continued)

If the problem is this....	Do this....
The tape drive does not respond to server commands.	Press and hold the unload button on the drive for 10 seconds to force a drive dump. The drive will save the dump and then reboot to allow communication to the drive to occur. Do not cycle power, as this will erase the contents of the dump.

Methods of Receiving Errors and Messages

Use Table 14 as a guide for identifying error codes and message codes reported by the Ultrium 2 Tape Drive, its enclosure (if applicable), or the server.

Note: The codes on the single-character display have different meanings, depending on whether they display during normal operations or while the drive is in maintenance mode. Codes that occur during normal operations are defined in Table 15 on page 67. Codes that occur while in maintenance mode are defined in Table 9 on page 36.

Table 14. Methods of receiving errors and messages for the IBM TotalStorage LTO Ultrium 2 Tape Drive

If the error or message was presented by....	Do this....
The enclosure's display (if the tape drive is enclosed in a library or autoloader)	Refer to the documentation for the enclosure.
The tape drive's single-character display and the status light flashes amber	See Table 15 on page 67. To determine the meaning of status light activity, see "Status Light" on page 32.
The tape drive's single-character display and the status light is solid amber	See Table 9 on page 36. To determine the meaning of status light activity, see "Status Light" on page 32.
SCSI log sense data (such as TapeAlert flags), SCSI drive sense data, or Fibre Channel autosense data at the server console	See Appendix B, "TapeAlert Flags" on page 97, Table 15 on page 67, or "Using Sense Data" on page 71.
Drive sense data sent to a library (if the tape drive is enclosed in a library)	Refer to your library's documentation, then see Table 15 on page 67.
The tape drive's error log	See Table 15 on page 67 and "Viewing the Drive Error Log" on page 76.

Descriptions and Corrective Actions for Errors and Messages

Table 15 gives descriptions of the errors and messages that pertain to the Ultrium 2 Tape Drive, and tells what to do when you receive them.

Attention: If the tape drive detects a permanent error and displays an error code other than 0, it automatically performs a drive dump. If you force a drive dump, the existing dump will be overwritten and data will be lost. After you force a drive dump, do not turn off the power to the tape drive or you may lose the dump data.

Table 15. Codes for error conditions and informational messages for the IBM TotalStorage LTO Ultrium 2 Tape Drive. The single-character display clears if you power-off the drive.

Code	Cause and Action
0	<p>No error occurred and no action is required. This code displays:</p> <ul style="list-style-type: none"> • When power is cycled (turned off, then on) to the tape drive. • When diagnostics have finished running and no error occurred. <p>Note: The single-character display is blank during normal operation of the tape drive.</p>
1	<p>Cooling problem. The tape drive detected that the recommended operating temperature was exceeded. Perform the following action:</p> <ol style="list-style-type: none"> 1. If a fan is present in the enclosure, ensure that it is rotating and is quiet. If not, replace the fan (for instructions about replacing the fan, see your enclosure's documentation). 2. Remove any blockage that prevents air from flowing freely through the tape drive. 3. Ensure that the operating temperature and airflow is within the specified range (see Chapter 2, "Specifications" on page 11). 4. If the operating temperature is within the specified range and the problem persists, replace the tape drive. <p>The error code clears when you power-off the tape drive or place it in maintenance mode.</p>
2	<p>Power problem. The tape drive detected that the externally supplied power is either approaching the specified voltage limits (the drive is still operating) or is outside the specified voltage limits (the drive is not operating). Perform the following action:</p> <ol style="list-style-type: none"> 1. Ensure that the power connector is properly seated. 2. Ensure that the proper dc voltages are being applied within the tolerances allowed (see Chapter 2, "Specifications" on page 11). 3. If the proper voltages are being applied but the problem persists, replace the tape drive. <p>The error code clears when you power-off the tape drive or place it in maintenance mode.</p>

Table 15. Codes for error conditions and informational messages for the IBM TotalStorage LTO Ultrium 2 Tape Drive (continued). The single-character display clears if you power-off the drive.

Code	Cause and Action
3	<p>Firmware problem. The tape drive determined that a firmware error occurred. Perform the following action:</p> <ol style="list-style-type: none"> 1. Collect a drive dump from one of the following: <p>Note: Do not force a new dump; the tape drive has already created one.</p> <ul style="list-style-type: none"> • Server's SCSI or Fibre Channel interface by using a device driver utility or system tool. To obtain a dump, determine whether your server is installed with a utility that can read files from the server's memory. If it is, use that utility to obtain the dump. For information about using IBM's utility programs to obtain drive dumps, see the <i>IBM Ultrium Device Drivers Installation and User's Guide</i>. To determine where to send a file that contains a drive dump to be analyzed, contact your OEM Product Application Engineer (PAE). • Enclosure (refer to the procedures for reading a drive dump in your enclosure's documentation) • Ultrium 2 Tape Drive (to read a drive dump, use Function Code 5 in Table 9 on page 36) 2. Power the tape drive off and on, then retry the operation that produced the error. 3. If the problem persists, download new firmware and retry the operation. 4. If the problem persists, send the drive dump that you collected in step 1 to your OEM Product Application Engineer (PAE). <p>The error code clears when you power-off the tape drive or place it in maintenance mode.</p>
4	<p>Firmware or tape drive problem. The tape drive determined that a firmware or tape drive hardware failure occurred. Perform the following action:</p> <ol style="list-style-type: none"> 1. Collect a drive dump from one of the following: <p>Note: Do not force a new dump; one already exists.</p> <ul style="list-style-type: none"> • Server's SCSI or Fibre Channel interface by using a device driver utility or system tool. To obtain a dump, determine whether your server is installed with a utility that can read files from the server's memory. If it is, use that utility to obtain the dump. For information about using IBM's utility programs to obtain drive dumps, see the <i>IBM Ultrium Device Drivers Installation and User's Guide</i>. To determine where to send a file that contains a drive dump to be analyzed, contact your OEM Product Application Engineer (PAE). • Enclosure (refer to the procedures for reading a drive dump in your enclosure's documentation) • Ultrium 2 Tape Drive (to read a drive dump, use Function Code 5 in Table 9 on page 36) 2. Power the tape drive off and on, then retry the operation that produced the error. The error code clears when you power-off the tape drive or place it in maintenance mode. 3. If the problem persists, download new firmware and retry the operation; if new firmware is not available, replace the tape drive.
5	<p>Tape drive hardware problem. The drive determined that a tape path or read/write error occurred. To prevent damage to the drive or tape, the drive will not allow you to insert a cartridge if the current cartridge was successfully ejected. The error code may clear when you cycle power to the tape drive or place it in maintenance mode. If the problem persists, replace the tape drive.</p>

Table 15. Codes for error conditions and informational messages for the IBM TotalStorage LTO Ultrium 2 Tape Drive (continued). The single-character display clears if you power-off the drive.

Code	Cause and Action
6	<p>Tape drive or media error. The drive determined that an error occurred, but it cannot isolate the error to faulty hardware or to the tape cartridge. Perform the following action:</p> <p>For Problems with Writing Data:</p> <p>If the problem occurred while the drive was writing data to the tape, and if you know the volume serial number (located on the cartridge label) of the tape cartridge loaded in the drive when the problem occurred, retry the operation with a different cartridge:</p> <ul style="list-style-type: none"> • If the operation succeeds, the original cartridge was defective. Copy data from the defective cartridge and discard it. • If the operation fails and another drive is available, insert the cartridge into the other drive and retry the operation. <ul style="list-style-type: none"> – If the operation fails, discard the defective cartridge. – If the operation succeeds, insert a scratch cartridge into the first drive and run the tape drive diagnostics (see Function Code 1 in Table 9 on page 36). <ul style="list-style-type: none"> - If the diagnostics fail, replace the drive. - If the diagnostics succeed, the error was temporary. • If the operation fails and another drive is not available, insert a scratch cartridge into the drive and run the tape drive diagnostics (see Function Code 1 in Table 9 on page 36). <ul style="list-style-type: none"> – If the diagnostics fail, replace the drive. – If the diagnostics succeed, discard the cartridge. <p>If the problem occurs with multiple tape cartridges or if you do not know the tape cartridge's volume serial number, run the tape drive diagnostics (see Function Code 1 in Table 9 on page 36):</p> <ul style="list-style-type: none"> • If the diagnostics fail, replace the tape drive. • If the diagnostics succeed, run the Test Head diagnostic (see Function Code H in Table 9 on page 36). <ul style="list-style-type: none"> – If the Test Head diagnostic fails, replace the tape drive. – If the Test Head diagnostic succeeds, replace the cartridges that caused the problem. <p>The error code clears when you remove the tape cartridge or place the drive in maintenance mode.</p> <p>For Problems with Reading Data:</p> <p>If the problem occurred while the drive was reading data from the tape, and if you know the volume serial number of the tape cartridge, perform one of the following procedures:</p> <ul style="list-style-type: none"> • If another drive is available, insert the cartridge into the other drive and retry the operation: <ul style="list-style-type: none"> – If the operation fails, discard the defective cartridge. – If the operation succeeds, insert a scratch cartridge into the first drive and run the tape drive diagnostics (see Function Code 1 in Table 9 on page 36): <ul style="list-style-type: none"> - If the diagnostics fail, replace the drive. - If the diagnostics succeed, the error was temporary. • If another drive is not available, insert a scratch cartridge into the drive and run the tape drive diagnostics (see Function Code 1 in Table 9 on page 36): <ul style="list-style-type: none"> – If the diagnostics fail, replace the drive. – If the diagnostics succeed, discard the cartridge. <p>If the problem occurs with multiple tape cartridges or if you do not know the tape cartridge's volume serial number, run the tape drive diagnostics (see Function Code 1 in Table 9 on page 36):</p> <ul style="list-style-type: none"> • If the diagnostics fail, replace the tape drive. • If the diagnostics succeed, run the Test Head diagnostic (see Function Code H in Table 9 on page 36). <ul style="list-style-type: none"> – If the Test Head diagnostic fails, replace the tape drive. – If the Test Head diagnostic succeeds, replace the cartridges that caused the problem. <p>The error code clears when you remove the tape cartridge or place the drive in maintenance mode.</p>

Table 15. Codes for error conditions and informational messages for the IBM TotalStorage LTO Ultrium 2 Tape Drive (continued). The single-character display clears if you power-off the drive.

Code	Cause and Action
7	<p>A high probability of media error. The tape drive determined that an error occurred because of a faulty tape cartridge. Try another tape cartridge. If the problem occurs with multiple tape cartridges, see “Resolving Media-Related Problems” on page 82.</p> <p>The error code clears when you remove the tape cartridge or place the drive in maintenance mode.</p>
8	<p>For SCSI drive:</p> <p>Tape drive or SCSI bus failure. The tape drive determined that a failure occurred in the tape drive’s hardware or in the SCSI bus. See “Fixing SCSI Bus Errors” on page 77. The error code clears 10 seconds after the drive detected the error or when you place the drive in maintenance mode.</p> <p>For Fibre Channel drive:</p> <p>Tape drive or Fibre Channel failure. The tape drive determined that a failure occurred in the tape drive’s hardware or in the Fibre Channel. It detects light through the fiber cable but cannot perform data communication properly. The length of the cable between the devices may exceed 500 m (1640 ft). See “Fixing Fibre Channel Errors” on page 79. The error code clears when the drive detects light and can communicate, or when you place the drive in maintenance mode.</p>
9	<p>Tape drive or LDI (RS-422) error. The tape drive determined that a failure occurred in the tape drive hardware or in the LDI (RS-422) connection. Run the LDI or RS-422 wrap test (see Function Code 7 in Table 9 on page 36):</p> <ul style="list-style-type: none"> • If the diagnostic fails, replace the tape drive. • If the diagnostic runs successfully, the problem is with the enclosure or the cable to the enclosure. Refer to your enclosure’s documentation. <p>The error code clears when you place the drive in maintenance mode.</p>
o, c, b, or h	<p>No error or message assigned. There may be a problem with the single-character display. Turn the power off, then on and determine whether all segments on the single-character display are lit. If so, you may have a down-level version of both your enclosure’s firmware and documentation (the documentation may not describe all of the available error codes). Refer to the latest version of the firmware or documentation.</p>
A	<p>Tape drive hardware problem. The tape drive determined that a problem occurred which degraded the operation of the tape drive, but it did not restrict continued use. If the problem persists, replace the tape drive. The drive is usable, though the single-character display continues to indicate an error and the status light flashes amber.</p> <p>The error code may clear when you cycle power to the tape drive or place it in maintenance mode.</p>
B	<p>No error or message is assigned. See error code 8 in this table.</p>
C	<p>The tape drive needs to be cleaned. Clean the tape drive. See “Cleaning the Drive Head” on page 35.</p> <p>The error code clears when you clean the tape drive or place it in maintenance mode.</p>
d	<p>Fibre Channel AL_PA conflict. More than one device has the same address. Each device must have its own unique AL_PA address. See “Setting the Arbitrated Loop Physical Address (Fibre Channel Drive Only)” on page 19.</p>
D	<p>No error or message assigned. See error code 0 in this table.</p>
E	<p>Informational message. The tape drive’s Fibre Channel port has been placed offline by another device or by an operator. This code is set when the Offline command is received from another device on the Fibre Channel interface. Determine why the device at the other end of the Fibre Channel (the server, switch, or other device) placed the drive offline.</p> <p>The drive is placed online when it receives the Online command from the Fibre Channel interface.</p> <p>After a reset, the drive comes online.</p>

Table 15. Codes for error conditions and informational messages for the IBM TotalStorage LTO Ultrium 2 Tape Drive (continued). The single-character display clears if you power-off the drive.

Code	Cause and Action
F	<p>The tape drive determined that no light is being received over the Fibre Channel. See “Fixing Fibre Channel Errors” on page 79.</p> <p>The error code clears when the drive detects light or when you place the drive in maintenance mode.</p>

Using Sense Data

When a tape drive encounters an error, it makes sense data available. You can use IBM device drivers to examine the sense data and determine errors. Instructions for downloading, installing, and properly configuring the IBM device drivers are available in the *IBM Ultrium Device Drivers Installation and User's Guide*. The IBM device drivers may conflict with some commercial software applications unless properly configured. To avoid conflicts on Windows operating systems, refer to your device driver's procedures for setting the driver to manual startup mode. For applications that use Open Systems device drivers that are provided by IBM (for example, AIX, Linux, Sun Solaris, HP-UX, Windows/NT, and Windows 2000), the *IBM Ultrium Device Drivers Installation and User's Guide* contains information about how to obtain sense data after an error has occurred.

If your application uses other device drivers, see the appropriate documentation for those drivers to obtain the sense data.

Raw sense data (as returned from the Ultrium 2 Tape Drive) is documented in the *IBM TotalStorage LTO Ultrium Tape Drive SCSI Reference*.

In addition to device drivers, other methods exist for obtaining sense data and error information. The sections that follow describe alternatives for gathering such information from the IBM AS/400, @server iSeries, RS/6000, and @server pSeries servers.

Obtaining Error Information from the AS/400 or iSeries with RISC Processor

For OS/400, sense data is provided by the System Service Tools application. To obtain error information from the AS/400 or iSeries by using the tool:

1. On the command entry line of the AS/400 Main Menu, type **STRSST** (Start System Service Tools) and press Enter.
2. Select Start a service tool.
3. Select Product activity log.
4. Select Analyze log.
5. On the Select System Data menu, select the Magnetic media option then specify the time period for searching the error log.
6. On the Select Analysis Report Options menu, specify a Device selection of 3580 and press Enter. Leave all other options at their default values.
7. On the Log Analysis Report menu, select the Display report option to display the desired error log. Figure 24 on page 72 shows a sample error log.

```

                                Display Detail Report for Resource

Name          Type      Model          Serial          Resource
TAP07         3580     002           00-00000       TAP07

Log ID . . . . . : 00452B54   Sequence . . . . . : 4732468
Date . . . . . : 08/14/02   Time . . . . . : 09:50:21
Reference code . . . . . : 9210   Secondary code . . . : 00000000
Table ID . . . . . : 63A00001   IPL source/state . . : B/3

Class . . . . . : Permanent
System Ref Code . . . . . : 63A09210
Illegal or unsupported tape unit response

Press Enter to continue.

F3=Exit          F4=Additional Information   F6=Hexadecimal report
F9=Address Information  F10=Previous detail report  F12=Cancel

```

Figure 24. Example of an error log from the AS/400 or IBM @server iSeries

8. Press F4 to view the sense data (see the example in Figure 25).

```

                                Display Additional Information for Resource

Name          Type      Model          Serial          Resource
TAP07         3580     002           00-00000       TAP07

SENSE DATA FOLLOWS. . . . . :
DATA OFFSET          0 1 2 3    4 5 6 7    8 9 A B    C D E F
00000000             70000500  0000001C  00000000  240000C0
00000010             00020000  00000000  00000000  00000000
00000020             058B0000

```

Figure 25. Example of sense data from the AS/400 or IBM @server iSeries

Obtaining Error Information from the RS/6000 or pSeries

The AIX® Tape and Media Changer Device Driver for the IBM RS/6000 or IBM @server pSeries provides logging to the system error log for a variety of errors. You can view the error log by issuing the AIX **errpt** command. Figure 26 on page 73 displays a sample drive error log; Figure 27 on page 74 displays a sample SCSI bus error log.

To view the error log:

1. At the AIX command line, type **errpt -a |pg** to display a detailed report.
2. Press Enter to scroll through the error log.
3. Type **q** to quit the error log at any time.

Example of a Drive Error Log:

In the SENSE DATA area of Figure 26, entries in bold are defined as follows:

Hexadecimal Code	Description
01	SCSI Command
0000, 0200, 0000	Command parameters
70	Byte 0 of SCSI sense data
03	Sense key
5200	ASC/ASCQ (Additional Sense Code/Additional Sense Code Qualifier)
20B0	FSC (Fault Symptom Code)
058A	Relative LPOS
02	SCSI ID

```

LABEL:          TAPE_ERR1
IDENTIFIER:     4865FA9B

Date/Time:     Wed Oct 11 11:39:43
Sequence Number: 25264
Machine ID:    000D090D4C00
Node ID:      tsm
Class:        H
Type:         PERM
Resource Name: rmt2
Resource Class: tape
Resource Type: LTO
Location:     40-60-00-2,0
VPD:
    Manufacturer.....IBM
    Machine Type and Model.....ULT3580-TD2
    Serial Number.....1300015078
    Device Specific.(FW).....0B70 (Firmware Level)
Description
TAPE OPERATION ERROR

Probable Causes
TAPE

User Causes
MEDIA DEFECTIVE
DIRTY READ/WRITE HEAD

Recommended Actions
FOR REMOVABLE MEDIA, CHANGE MEDIA AND RETRY
PERFORM PROBLEM DETERMINATION PROCEDURES

Detail Data
SENSE DATA
0602 0000 0100 0000 0200 0000 0000 0000 0000 0000 7000 0300 0000 001C 0000 0000
5200 0700 20B0 0000 0000 0000 0000 0000 0000 0000 058A 0200 0000 0000 0000 0000
0000 0000 0000 0000 0000 0000 0000 0000 0000 0000 0000 0000 0000 0000 0000
0000 0000 0000 0000 0000 0000 0000 0000 0000 0000 0000 0000 0000 0000
    
```

Figure 26. Example of an AIX ERRPT Drive Error Log

Example of a SCSI Bus Error:

```
LABEL:          SCSI_ERR10
IDENTIFIER:     0BA49C99

Date/Time:     Wed Oct 18 09:55:32
Sequence Number: 16140
Machine Id:    00003ABF4C00
Node Id:      ofgtsm
Class:        H
Type:         TEMP
Resource Name: scsi3
Resource Class: adapter
Resource Type: sym896
Location:     40-59
VPD:
    Product Specific.( ).....DUAL CHANNEL PCI TO ULTRA2 SCSI
                                ADAPTER
    Part Number.....03N3606
    EC Level.....F71335
    Manufacture ID.....A16592
    Serial Number.....0749

Description
SCSI BUS ERROR

Probable Causes
CABLE
CABLE TERMINATOR
DEVICE
ADAPTER

Failure Causes
CABLE LOOSE OR DEFECTIVE
DEVICE
ADAPTER

Recommended Actions
PERFORM PROBLEM DETERMINATION PROCEDURES
CHECK CABLE AND ITS CONNECTIONS

Detail Data
SENSE DATA
0001 0017 0000 0000 0000 0091 0000 0000 0000 0000 0000 0000 0000 0000 0000
0000 0000 0000 4304 0000 0000 0000 0000 2000 0003 0203 6760 9808 0000 F7FB E1B8
0000 0015 000B 0210 0678 C800 0000 8200 8277 1B20 00A2 ED00 0000 0002 FFFF FFFF
00FF 0000 111F F000 F3DF F110
```

Figure 27. Example of an error that suggests a SCSI bus problem

Obtaining a Drive Dump

You can obtain a drive dump by selecting a function code on the IBM TotalStorage LTO Ultrium 2 Tape Drive or by using a device driver utility (or a system tool) on the server. The sections that follow describe each method.

Using the Drive to Obtain a Dump

To obtain a drive dump directly from the IBM TotalStorage LTO Ultrium 2 Tape Drive:

1. Make sure that no cartridge is in the drive.
2. Within a 1.5-second interval, press the unload button three times. The status light becomes solid amber, which means that the drive is in maintenance mode.
3. Press the unload button once per 1.5 seconds until 5 appears in the single-character display.
4. To select the function, press and hold the unload button for 3 seconds. After you release the button, C flashes. Within 60 seconds, insert a scratch data cartridge that is not write-protected. After you insert the cartridge, 5 flashes and the drive writes the dump data to the scratch tape. When the function is complete, the drive rewinds and unloads the tape.
5. Insert the tape into a drive.
6. From the server, issue the SCSI READ command to read the dump from the tape to a file or electronic image (you may need to issue the command several times to read the complete dump).
7. To determine where to send the file for analysis, contact your OEM Product Application Engineer (PAE).

Using a Device Driver Utility to Obtain a Dump

To obtain a drive dump by using a device driver utility, determine whether your server is installed with a utility that can read files from the server's memory. If it is, use that utility to obtain the drive dump.

For information about using IBM's utility programs to obtain drive dumps, see the *IBM Ultrium Device Drivers Installation and User's Guide*.

To determine where to send a file that contains a drive dump to be analyzed, contact your OEM Product Application Engineer (PAE).

Viewing the Drive Error Log

The Ultrium 2 Tape Drive keeps an error log that you can use to identify and correct errors. The log contains the 10 most recent error codes, which appear (one at a time) on the single-character display.

To view the drive error log:

1. Make sure that no cartridge is in the drive.
2. Within a 1.5-second interval press the unload button three times. The status light becomes solid amber, which means that the drive is in maintenance mode.
3. Press the unload button once per 1.5 seconds until **9** appears in the single-character display.
4. Press and hold the unload button for 3 seconds to view the most recent error code.
5. Refer to Table 15 on page 67 to determine the meaning of the code and the action to take.
6. Press the unload button to view the next error code. (The codes are ordered; the most recent is presented first and the oldest (tenth) is presented last.)
7. Continue to press the unload button until the 10 error codes have been displayed. After you display the tenth error code, the drive automatically exits maintenance mode.

To redisplay the error codes, repeat steps 1 through 7.

Resolving Problems Reported by the Server

The procedure for fixing SCSI bus or Fibre Channel errors varies, depending on whether the error is consistent or intermittent, and whether your configuration contains single or multiple Ultrium 2 Tape Drives. The sections that follow describe how to fix each type of error.

Fixing SCSI Bus Errors

Note: If you are using a Storage Area Network (SAN) Data Gateway to convert a drive with a SCSI interface to a Fibre Channel interface, ensure that the problem is occurring between the SAN Data Gateway and the drive by running the SCSI wrap test on the drive and running the SCSI loopback test on the SAN Data Gateway. (To run the SCSI wrap test, see Function Code 6 in Table 9 on page 36; to run the SCSI loopback test, refer to the section about that test in the *IBM Storage Area Network Gateway Module Setup, Operator, and Service Guide*.) If you are using a Fibre Channel drive and are having problems, see “Fixing Fibre Channel Errors” on page 79.

Fixing a Consistent Error with a Single Drive on a SCSI Bus

1. Ensure that the power is on to the Ultrium 2 Tape Drive.
2. Ensure that the tape drive’s SCSI address is the same as the SCSI address assigned by the server.
3. Run the SCSI wrap test (see Function Code 6 in Table 9 on page 36).
 - If the test runs successfully, replace the SCSI terminator first, then the SCSI cable and the interposer (if installed). Repeat the operation that caused the error. If you replaced the SCSI terminator or SCSI cable and the problem persists, the fault is with the server’s hardware or software. To isolate the cause of the failure, refer to the server’s service documentation.
 - If the test fails, replace the tape drive (see “Removing a SCSI Tape Drive from an Enclosure” on page 83).

Fixing a Consistent Error with Multiple Drives on a SCSI Bus

When a consistent error occurs in a configuration that has multiple tape drives on the SCSI bus, you must determine if the problem exists with more than one tape drive. If the problem is with all of the devices on the SCSI bus, the bus is stuck in a SCSI phase and cannot change to another phase or the SCSI cable from the server to the first device is defective.

1. Ensure that the SCSI cable from the server to the first device is connected.
2. Disconnect all but the first tape drive on the SCSI bus. Move the terminator to the first SCSI device.
3. Run a device driver utility (such as IBM’s *ntutil* or *tapeutil*) to determine whether the error will occur.
 - If the error occurs, run the SCSI wrap test on the first tape drive (see Function Code 6 in Table 9 on page 36).
 - If the test runs successfully, replace the SCSI terminator first, then the SCSI cable and the interposer (if installed) to the first tape drive. Repeat the operation that caused the error. If you replaced the SCSI terminator or SCSI cable and the problem persists, the fault is with the server’s hardware or software. To isolate the cause of the failure, refer to the server’s service documentation.
 - If the test fails, replace the tape drive (see “Removing a SCSI Tape Drive from an Enclosure” on page 83).

- If the error does not occur, connect one tape drive at a time back to the bus and repeat step 3 for each tape drive until you can identify which drive is defective.

Note: Ensure that the SCSI terminator is always on the last tape drive on the SCSI bus.

4. Determine if the problem is with only one tape drive or with two or more tape drives.
 - If the problem is with only one tape drive, run the SCSI wrap test on that tape drive (see Function Code 6 in Table 9 on page 36).
 - If the test runs successfully, replace the SCSI terminator first, then the SCSI cable to that tape drive and interposer (if installed).
 - If the test fails, replace the tape drive (see “Removing a SCSI Tape Drive from an Enclosure” on page 83).
 - If the problem is with two or more tape drives, locate the first tape drive that has the error and replace the SCSI cable that connects the tape drive and the interposer (if installed).

Fixing an Intermittent Error with a Single Drive on a SCSI Bus

1. Replace the SCSI terminator on the tape drive.
2. Run the operation that caused the error. If the problem persists, the problem may be with the cable.
3. Isolate which cable is causing the problem by replacing one cable at a time and running the operation that caused the error after each replacement. If the problem persists after all cables have been replaced, the problem may be with the Ultrium 2 Tape Drive.
4. Replace the tape drive (see “Removing a SCSI Tape Drive from an Enclosure” on page 83). If the problem persists, the problem is with your server. Consult your server’s documentation.

Fixing an Intermittent Error with Multiples Drives on a SCSI Bus

Refer to the server’s error logs to determine which tape drive is the source of the problem:

- If only one tape drive is reporting a SCSI failure, replace that tape drive (see “Removing a SCSI Tape Drive from an Enclosure” on page 83).
- If multiple tape drives are reporting SCSI failures, the problem may be with the terminator or the SCSI cables:
 - Replace the terminator and run the operation that caused the error. If the problem persists, the problem may be with the cables.
 - Isolate which cable is causing the problem by replacing one cable at a time and run the operation that caused the error after each replacement.

Fixing Fibre Channel Errors

If you are connected to a Fibre Channel Storage Area Network (SAN) by using a SAN Data Gateway, use the *IBM Storage Area Network Gateway Module Setup, Operator, and Service Guide* to determine whether the problem is occurring between the drive and the SAN Data Gateway. If you are using a SCSI drive and are having SCSI problems, see “Fixing SCSI Bus Errors” on page 77.

Starting Problem Determination

Before starting the problem determination, perform the following steps:

1. Determine the type of Fibre Channel topology that you are using (see page 6). Ensure that the drive and the port to which it is attached are configured in compatible topologies.
2. Using this guide or the service guides of associated switch, hub, or fiber products, try to determine where the problem exists (whether in the drive, cable, or the device to which the drive and cable attach).
3. Ensure that the configuration and software levels are supported (see “Fibre Channel Attachment” on page 6).
4. Ensure that the Fibre Channel cables are installed correctly. Refer to the appropriate steps in Chapter 3, “Installing the Tape Drive” on page 13.
5. Go to one of the following procedures:
 - “Fixing a Consistent Error with a Single Drive on a Fibre Channel Loop”
 - “Fixing a Consistent Error with Multiple Drives on a Fibre Channel Loop” on page 80
 - “Fixing a Consistent Error in a Point-to-Point Topology” on page 80
 - “Fixing Intermittent Fibre Channel Errors” on page 81

Fixing a Consistent Error with a Single Drive on a Fibre Channel Loop

1. Ensure that the tape drive is powered on.
2. Verify that the tape drive’s serial number is the same as the drive serial number that the server program is using.
3. Ensure that the drive’s Fibre Channel AL_PA is set correctly, that it is on the loop, and that it is not being used by another device (see “Setting the Arbitrated Loop Physical Address (Fibre Channel Drive Only)” on page 19). The tape drive must be able to detect light and communicate with the server.
4. Run the Fibre Channel wrap test at the drive’s Fibre Channel connector (see Function Code 6 in Table 9 on page 36).
 - If the test fails, replace the tape drive.
 - If the test is successful, go to step 5.
5. Run the Fibre Channel wrap test at the end of the fiber cable (see Function Code 6 in Table 9 on page 36).
 - If the test fails, replace the fiber cable.
 - If the test is successful, go to step 6.
6. Check the Fibre Channel cable connection at the server.
7. Using a device driver utility such as *ntutil* or *tapeutil*, verify that the drive is properly configured and available at the server.
8. If the problem persists, the fault may be with the server’s hardware or software. Refer to your server’s service manual.

9. When the problem is corrected (or determined to be a server problem), restore all of the fiber cables to their correct position.

Fixing a Consistent Error with Multiple Drives on a Fibre Channel Loop

Use the following procedure to determine if all of the drives on the Fibre Channel have the problem:

1. Use a device driver utility (such as *ntutil* or *tapeutil*) to verify that the drive is available and properly configured at the server.
2. Determine the type of Fibre Channel topology that you are using (see page 6).
3. Using this guide or the service guides of associated switch, hub, or fiber products, try to isolate which part of the Fibre Channel Storage Area Network (SAN) is experiencing problems.
4. Perform one of the following:
 - If the problem exists on a small number of drives, go to “Fixing a Consistent Error with a Single Drive on a Fibre Channel Loop” on page 79.
 - If the problem exists with a large number of drives, perform the following steps:
 - a. Disconnect all except one failing drive on the Fibre Channel.
 - b. Run the Fibre Channel wrap test to determine if a failure occurs on that drive (see Function Code 6 in Table 9 on page 36). If it does, perform the procedure in “Fixing a Consistent Error with a Single Drive on a Fibre Channel Loop” on page 79.
 - c. Continue to connect one drive at a time to the Fibre Channel loop.
5. When the problem is corrected, restore all of the Fibre Channel cables to their correct position.

Fixing a Consistent Error in a Point-to-Point Topology

1. Ensure that the tape drive is powered on.
2. Verify that the tape drive’s serial number is the same as the drive serial number that the server program is using.
3. Ensure that the drive is connected to the host or switch. The drive must be able to detect light and communicate with the server.
4. Run the Fibre Channel wrap test at the drive’s Fibre Channel connector (see Function Code 6 in Table 9 on page 36).
 - If the test fails, replace the tape drive.
 - If the test is successful, go to step 5.
5. Run the Fibre Channel wrap test at the end of the fiber cable (see Function Code 6 in Table 9 on page 36).
 - If the test fails, replace the fiber cable.
 - If the test is successful, go to step 6.
6. Check the Fibre Channel cable connection at the server.
7. Using a device driver utility such as *ntutil* or *tapeutil*, verify that the drive is properly configured and available at the server.
8. If the problem persists, the fault may be with the server’s hardware or software. Refer to your server’s service manual.
9. When the problem is corrected (or determined to be a server problem), restore all of the fiber cables to their correct position.

Fixing Intermittent Fibre Channel Errors

1. Determine the type of Fibre Channel topology that you are using (see page 6).
2. Ensure that the configuration and software levels are supported (see “Fibre Channel Attachment” on page 6).
3. Check that each Fibre Channel cable does not exceed 500 m (1640 ft).
4. Ensure that all Fibre Channel cables are installed correctly. Refer to the appropriate steps in Chapter 3, “Installing the Tape Drive” on page 13.
5. Using this guide or the service guides of associated switch, hub, or fiber products, determine that a problem exists between the drive, drive cable, and the device to which they attach. Try to isolate which part of the Storage Area Network (SAN) is experiencing problems.
6. Using this guide or the service guides of associated switch, hub, or fiber products, verify that the SAN configurations are correct (such as switch zoning for drive sharing).
7. Obtain all errors reported by the drive to the server (see “Using Sense Data” on page 71), then contact your OEM Product Application Engineer (PAE) for error analysis.

Resolving Media-Related Problems

To resolve problems that are related to media, the Ultrium 2 Tape Drive's firmware includes:

- Test Cartridge & Media diagnostic that verifies whether a suspect cartridge and its magnetic tape are acceptable for use.
- Statistical Analysis and Reporting System (SARS) to assist in isolating failures between media and hardware. To determine the cause of failure, SARS uses the cartridge performance history that is saved in the cartridge memory (CM) and the drive performance history that is kept in the drive's flash erasable programmable read-only memory (EPROM). Any failures that SARS detects are reported as TapeAlert flags on the server (see Appendix B, "TapeAlert Flags" on page 97).

Attention: If you insert the IBM LTO Ultrium Data Cartridge into another manufacturer's tape drive, the SARS data in the cartridge memory may become lost or invalid.

If you encounter a media-related problem, use the following procedure:

Attention: When you run the Test Cartridge & Media diagnostic, data on the suspect tape is overwritten. Use only a scratch data cartridge to run the test.

1. If possible, run the tape cartridge in a different tape drive. If the operation in the other tape drive fails and 6 or 7 displays, replace the media. If the operation succeeds, run the Test Cartridge & Media diagnostic (see Function Code E in Table 9 on page 36).
2. If the Test Cartridge & Media diagnostic fails, replace the media. If it runs successfully, clean the tape drive and run the tape drive diagnostics (see "Cleaning the Drive Head" on page 35 and Function Code 1 in Table 9 on page 36).
3. If the tape drive diagnostics fail, replace the tape drive. If the tape drive diagnostics run successfully, perform the operation that produced the initial media error.

Chapter 7. Servicing the Tape Drive

Removing a SCSI Tape Drive from an Enclosure

To remove an IBM TotalStorage LTO Ultrium 2 Tape Drive Model T400 from an enclosure, perform the following steps:

1. Ensure that the tape drive does not contain a tape cartridge.
2. Deconfigure the drive from the server (for instructions, see your server's documentation).
3. Turn off the power to the enclosure. Disconnect the power cable from the enclosure and the electrical outlet.
4. Remove the cover of the enclosure.
5. Disconnect the internal power cable from the power connector (see **4** in Figure 28).
6. If connected, disconnect the internal LDI (RS-422) cable from the LDI (RS-422) connector **5**.
7. Disconnect the internal SCSI cable from the SCSI connector **2**.
8. Perform one of the following procedures on the SCSI ID connector **3**:
 - If your enclosure uses an internal SCSI ID switch, disconnect it from the SCSI ID connector.
 - If your enclosure uses jumpers to set the SCSI ID, do not remove them from the connector.
9. Remove the mounting screws from the side brackets of the chassis (see **2** in Figure 8 on page 26).
10. Remove the tape drive from the enclosure.
11. To reassemble, reverse these steps.

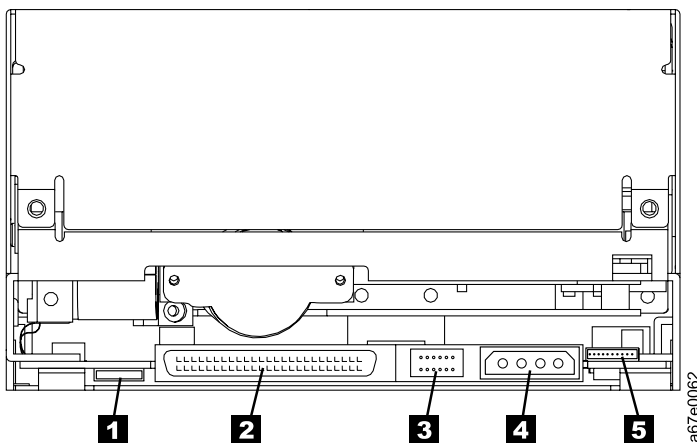

Figure 28. Rear view of the IBM TotalStorage LTO Ultrium 2 Tape Drive Model T400 (SCSI drive)

Removing a Fibre Channel Tape Drive from an Enclosure

To remove an IBM TotalStorage LTO Ultrium 2 Tape Drive Model T400F from an enclosure, perform the following steps:

1. Ensure that the tape drive does not contain a tape cartridge.
2. Deconfigure the drive from the server, switch, or hub (for instructions, see the documentation for these devices).
3. Turn off the power to the enclosure. Disconnect the power cable from the enclosure and the electrical outlet.
4. Disconnect the internal power cable from the power connector (see **1** in Figure 29).
5. If connected, disconnect the internal LDI (RS-422) cable from the LDI (RS-422) connector **6**.
6. Disconnect the internal fiber cable from the Fibre Channel connector **5**.
7. Disconnect the LID/status connector **3**.
8. Disconnect the FC configuration/status connector **4**.
9. Remove the mounting screws from the side brackets of the chassis (see **2** in Figure 8 on page 26).
10. Remove the tape drive from the enclosure.
11. To reassemble, reverse these steps.

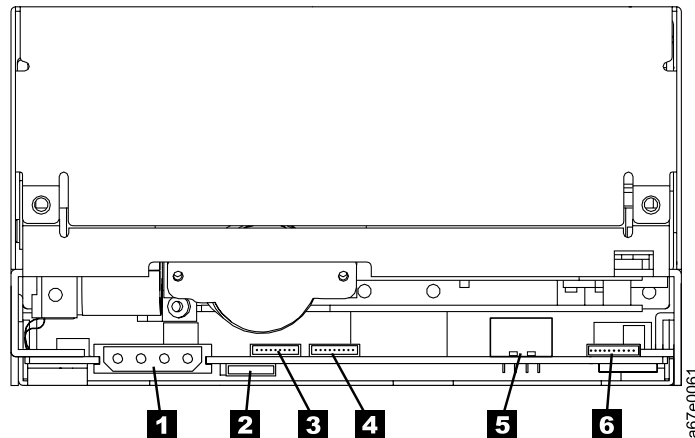

Figure 29. Rear view of the IBM TotalStorage LTO Ultrium 2 Tape Drive Model T400F (Fibre Channel drive)

Manually Removing a Tape Cartridge

If problem-determination procedures identify the Ultrium 2 Tape Drive as the source of a problem, you can optionally perform one of the following:

- Replace the entire unit. For more information, contact your OEM Product Application Engineer (PAE).
- Manually remove the cartridge (see “Removing the Cartridge”).
- If you are unable to manually remove the cartridge, contact trained service personnel for assistance. Refer the service personnel to the instructions in “Fixing an Internal Jam” on page 88.

Attention:

If you are not a trained service person, do not attempt to open the drive for repairs. Attempting a repair other than the manual removal of a tape cartridge will void your warranty.

Removing the Cartridge

If a tape cartridge fails to eject from the Ultrium 2 Tape Drive, you can manually remove the cartridge. The following tools are required for the procedure:

- 2.5-mm allen wrench
- Small-blade screwdriver or potentiometer-setting tool
- 2-mm hex wrench
- #3 Phillips screwdriver
- Needle-nose pliers
- Flashlight (optional)



Attention: Before performing this procedure, note the following:

- Ensure that you have attempted all normal methods of removing the tape cartridge from the drive. Refer to “Removing a Tape Cartridge” on page 35 and the troubleshooting tips in Table 13 on page 65.
- This procedure may damage the stuck tape cartridge. If you use this procedure, copy the data from the stuck cartridge to another cartridge. If you choose to reuse the stuck cartridge, refer to the instructions in “Repositioning or Reattaching a Leader Pin” on page 55. If you believe the cartridge has been damaged, replace it.
- Do not use a power screwdriver to perform this procedure because it can destroy the tape.
- Never touch the head or electronic components within the drive. Touching may cause contamination or damage by electrostatic discharge.

To manually remove a tape cartridge, perform the following steps:

1. Place the drive so that the front faces you, then tilt it on its left side (see Figure 30).
2. Locate the access hole at the bottom of the unit (see **1** in Figure 30).
3. Insert a 2.5-mm allen wrench into the access hole and position the wrench so that it is seated in the screw of the supply reel motor.
4. Push open the door of the tape load compartment and locate the flag **2** on the drive's takeup reel.

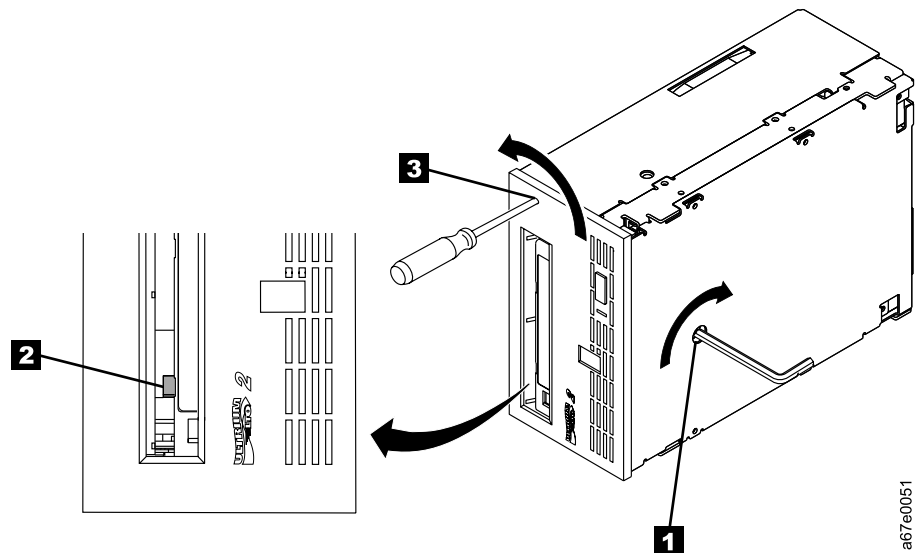

Figure 30. Determining whether the tape is broken

Attention: In the following step, rotate the allen wrench clockwise, not counterclockwise. A counterclockwise motion may damage the tape.

5. To determine whether the tape is broken, watch the flag **2** on the drive's takeup reel while you rotate the allen wrench **1** clockwise (do not let the wrench move counterclockwise):
 - If you feel resistance to the allen wrench while attempting to turn the supply reel motor screw clockwise, go to step 7 on page 87.
 - If the takeup reel turns when you rotate the supply reel motor screw clockwise with the allen wrench, the tape is not broken. Go to step 6 on page 87.
 - If the takeup reel does not turn when you rotate the supply reel motor screw clockwise with the allen wrench and if supply reel motor screw rotates freely, the tape is broken. You must determine the location of the leader block. To do so, insert a small-blade screwdriver or potentiometer-setting tool into the access hole for the loader motor gear **3**. Rotate the screwdriver counterclockwise. You may have to rotate for a lengthy period:
 - If the cartridge moves up, the tape is completely in the cartridge and the leader block is in the home position. Continue rotating the screwdriver until the cartridge ejects. Remove the cartridge.
 - If you feel resistance and the cartridge does not move up, the leader block is not in the home position. Go to "Fixing an Internal Jam" on page 88.

6. Continue to rotate the allen wrench until you feel resistance. The tape has been rewound as far as it can go without unthreading.

Note: The number of required rotations depends on where the beginning of the tape is on the cartridge's takeup reel. You may have to rotate the allen wrench for a lengthy period.

7. With the allen wrench still inserted into the bottom access hole, insert a small-blade screwdriver or potentiometer-setting tool into the access hole for the loader motor gear **3**.
8. While keeping torque on the supply reel motor screw and rotating the allen wrench **1** clockwise, rotate the loader motor gear with the small-blade screwdriver **3** counterclockwise (see arrow). As you rotate the screwdriver, the allen wrench moves slightly.
9. With the small-blade screwdriver, continue to rotate the loader motor gear in the unload direction (counterclockwise):
 - If you feel no resistance to the allen wrench and the cartridge slowly moves up and out of the tape load compartment to the fully ejected position, the procedure was successful. Remove the small-blade screwdriver and go to step 10.
 - If you feel resistance to the allen wrench and the cartridge does not move, the loader mechanism is jammed or the leader block is not at the home position. Remove the small-blade screwdriver and go to "Fixing an Internal Jam" on page 88.
10. Remove the tape cartridge.
11. To ensure that the drive operates properly, refer to page 36 and select Function Code 1 - Run Tape Drive Diagnostics.

After you remove the stuck tape cartridge, copy the data on the tape to another tape. Then, if appropriate, return the stuck tape cartridge in its original packaging or in the packaging from its replacement to your reseller. If the leader pin detached from the tape in the cartridge, go to "Repositioning or Reattaching a Leader Pin" on page 55.

Fixing an Internal Jam



Attention: This procedure must be performed only by trained service personnel.

If problem-determination procedures identify the Ultrium 2 Tape Drive as the source of a problem, replace the entire unit. If you are not a trained service person, do not attempt to open the drive for repairs. Attempting a repair other than the manual removal of a tape cartridge will void your warranty.

Before performing this procedure, ensure that you have completed the steps that begin on page 86. Do not attempt this procedure until you have completed these steps.

If you have reached this point, the tape is broken or the leader pin dropped (or looked like it dropped) from the leader block. To fix these conditions, perform the following procedure.

1. If the drive is mounted in an enclosure, perform the procedure to remove it (see “Removing a SCSI Tape Drive from an Enclosure” on page 83 or “Removing a Fibre Channel Tape Drive from an Enclosure” on page 84).
2. Place the drive on a nonslip surface.
3. Remove the cover of the drive by performing the following steps:
 - a. Use an appropriate tool to remove the three screws and washers (see **1** in Figure 31 on page 89) that secure the bezel **2**. Remove the bezel.
 - b. Use a screwdriver to remove the four cover-mounting screws and washers **3**.
 - c. Remove the cover by lifting it up. Set the cover aside.

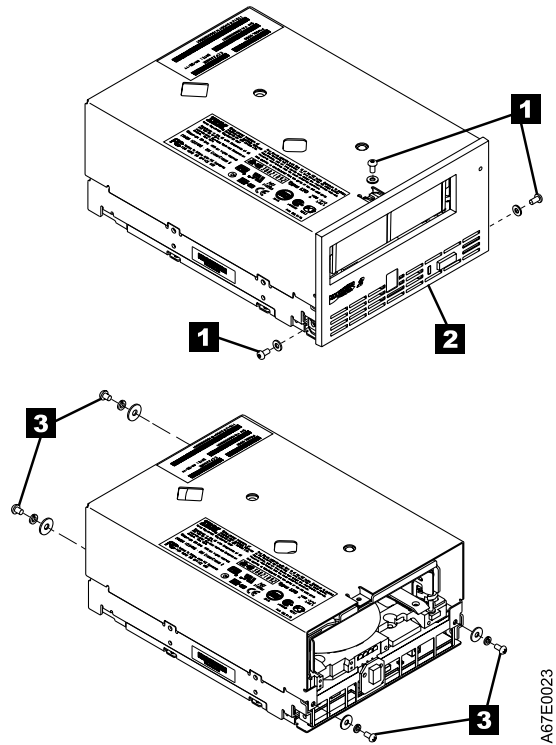

Figure 31. Removing the top cover of the drive

4. Examine the drive to determine the cause of the problem:
 - If the tape is broken, do not attempt repair. Return the drive and the stuck tape to your reseller for maintenance (note that your tape will be scrapped).
 - If the leader pin dropped from the leader block, go to step 5 on page 90 and continue this procedure.
 - If the leader block pulled the tape (but not the pin) from the spool so that it looks like the pin was dropped, go to step 5 on page 90 and continue this procedure.

5. Place the tape drive so that the front faces you, then tilt it on its left side (see Figure 32).
6. At the bottom of the drive, locate the access hole (**1** in Figure 32).



Attention: In the following steps, do not allow drive components to touch the head **2**. Damage may result to the head.

7. Insert a 2.5-mm allen wrench into the access hole and position the wrench so that it is seated in the screw of the supply reel motor.

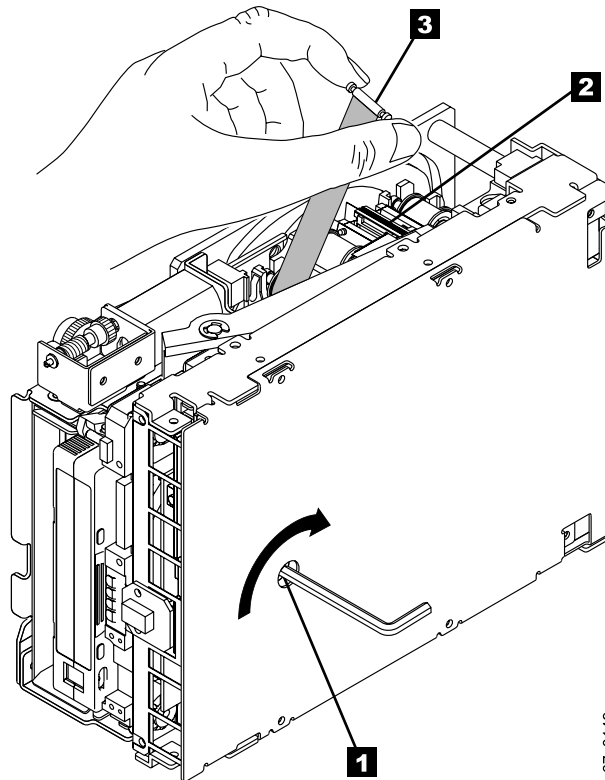

a67s0149

Figure 32. Rewinding the leader pin into the tape cartridge

8. With clean needle-nose pliers, grasp the end of the leader pin and pull it out of the cartridge so that you can grip it with your fingers (see **3** in Figure 32).

Note: If the leader pin is not connected to the tape, set the pin aside. After you remove the cartridge, reattach the pin (see “Repositioning or Reattaching a Leader Pin” on page 55).

9. While keeping the tape taut with your fingers, rotate the allen wrench clockwise **1** to wind the excess tape into the cartridge. Guide the leader pin toward the cartridge and drop it inside the cartridge door. Ensure that no tape is left outside of the cartridge. Remove the allen wrench.

Note: Do not attempt to seat the leader pin into the cartridge's clips; this will interfere with the motion of the leader block.

10. Manually rotate the loader motor gear (see **1** in Figure 33) in the unload direction (counterclockwise) until the leader block **2** reaches the last roller **3**.
11. While manually rotating the loader motor gear in the unload direction, guide the end of the leader block **2** into the white guide block **4**.

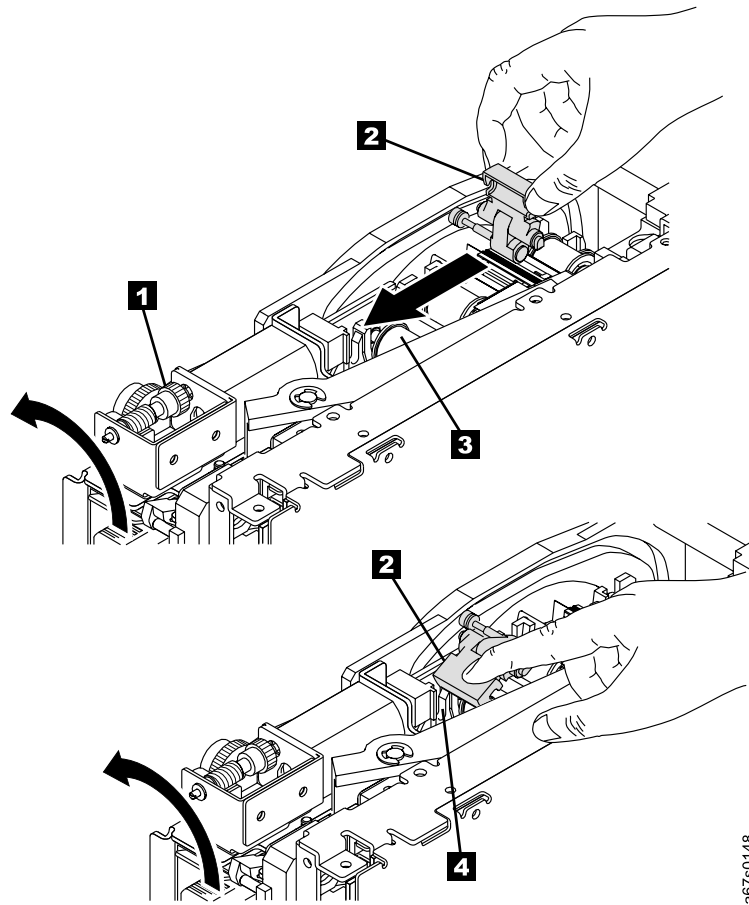

Figure 33. Guiding the leader block into the home position

12. Rotate the loader motor gear in the unload direction until the leader block is fully inside the drive (see **1** in Figure 34).

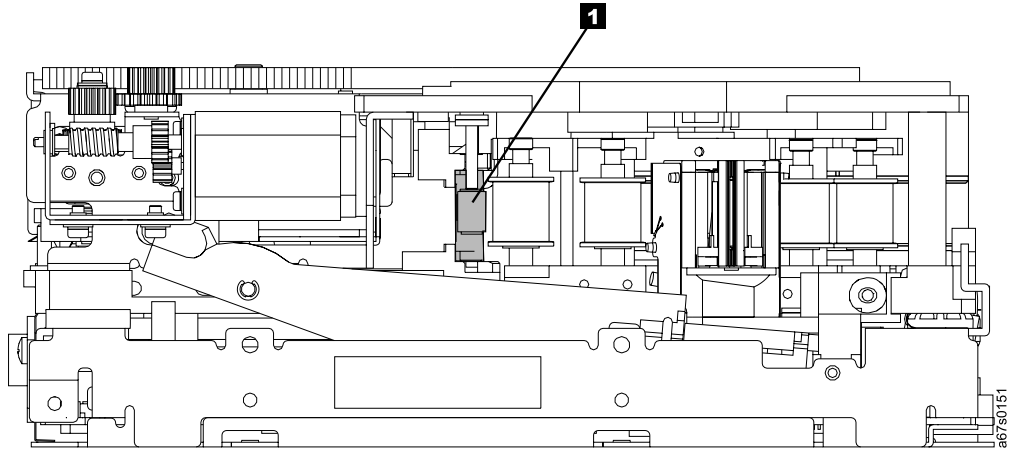

Figure 34. Rotating the loader motor gear until the leader block is fully inside the drive. The drive is shown on its side. The head is on the right and the arm of the head brush at the bottom of the figure.

13. Continue to rotate the loader motor gear counterclockwise. The leader block retracts and occupies the opening to the drive (see **1** in Figure 35).

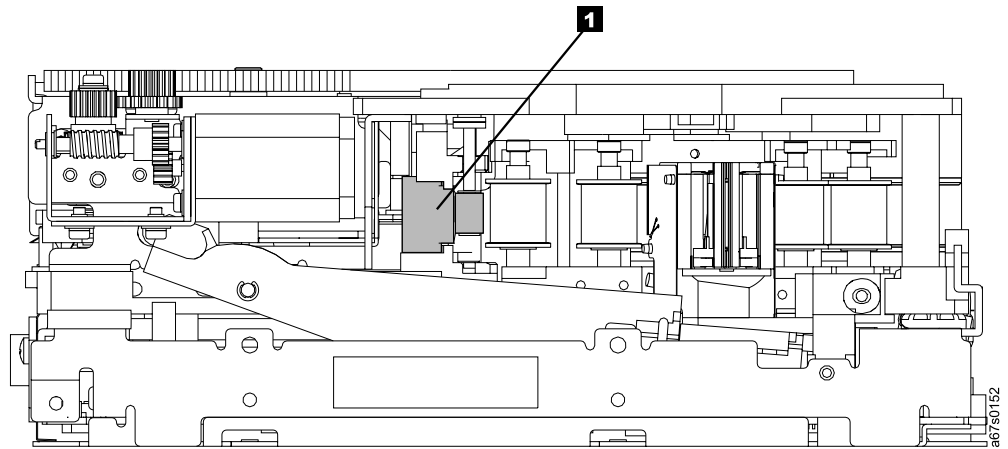

Figure 35. Rotating the loader motor gear so that the leader block retracts. The drive is shown on its side. The head is on the right and the arm of the head brush at the bottom of the figure.

14. Rotate the loader motor gear counterclockwise until you feel resistance and the cartridge rises and ejects (see Figure 36).

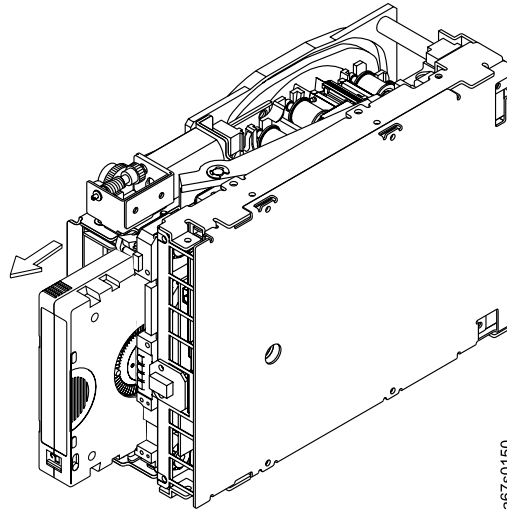

Figure 36. Rotating the loader motor gear until the cartridge ejects

15. Remove the tape cartridge. If the leader pin is not seated correctly in the cartridge, see “Repositioning or Reattaching a Leader Pin” on page 55.
16. Copy the data on the stuck tape cartridge to another cartridge. If appropriate, return the stuck tape cartridge for analysis in its original packaging or in the packaging from its replacement.
17. Reassemble the tape drive by reversing the preceding steps.
18. To ensure that the drive operates properly, refer to page 36 and select Function Code 1 - Run Tape Drive Diagnostics.

If you need help with this procedure, contact your OEM Product Application Engineer (PAE).

Appendix A. Tools and Supplies

Table 16 lists the tools and supplies that you can use with the IBM TotalStorage LTO Ultrium 2 Tape Drive. To order tools and supplies, contact your OEM Product Application Engineer (PAE) or visit the web at <http://www.ibm.com/storage/lto>.

Table 16. Tools and supplies for the IBM TotalStorage LTO Ultrium 2 Tape Drive

IBM Part Number	Product Description
08L9129	Leader pin reattachment kit
- -	2.5-mm allen wrench (procure locally)
- -	Plastic or blunt-end tweezers (procure locally)
08L9870	IBM TotalStorage LTO Ultrium 200 GB Data Cartridge
08L9124	IBM LTO Ultrium Cleaning Cartridge
35L2086	IBM TotalStorage Cleaning Cartridge (Ultrium LTO 2)
19P5897	IBM TotalStorage LTO Ultrium Data Cartridge bar code labels
08L9267	IBM LTO Ultrium Cleaning Cartridge bar code labels
11P3847	Single port Fibre Channel wrap plug
19P5424	Fibre Channel duplex adapter
35L1782	SCSI Y-cable
19P0051	0.5-m (1.6-ft) SCSI cable
19P0052	5.0-m (16-ft) SCSI cable
19P0053	10-m (32-ft) SCSI cable
05H4651	25-m (82-ft) SCSI cable
19K1252	5-m (16-ft) fiber cable
11P3880	13-m (43-ft) fiber cable
19K1253	25-m (82-ft) fiber cable
11P3884	61-m (200-ft) fiber cable
11P3885	Custom-length fiber cable

Appendix B. TapeAlert Flags

TapeAlert is a patented technology and standard of the American National Standards Institute (ANSI) that defines conditions and problems that are experienced by tape drives. The technology enables a server to read TapeAlert flags from a tape drive through the SCSI, Fibre Channel, or Library/Drive Interface (LDI or RS-422 interface). The server reads the flags from Log Sense Page 0x2E. This appendix lists the TapeAlert flags that are supported by the IBM TotalStorage LTO Ultrium 2 Tape Drive.

TapeAlert Flags Supported by the Drive

TapeAlert Flags Supported by the IBM TotalStorage LTO Ultrium 2 Tape Drive				
Flag Number	Flag Parameter (in hex)	Flag	Description	Action Required
3	03h	Hard error	Set for any unrecoverable read, write, or positioning error. (This flag is set in conjunction with flags 4, 5, or 6.)	See the Action Required column for Flag 4, 5, or 6 in this table.
4	04h	Media	Set for any unrecoverable read, write, or positioning error that is due to a faulty tape cartridge.	Replace the tape cartridge.
5	05h	Read failure	Set for any unrecoverable read error where isolation is uncertain and failure could be due to a faulty tape cartridge or to faulty drive hardware.	If Flag 4 is also set, the cartridge is defective. Replace the tape cartridge. If Flag 4 is not set, see error code 6 in Table 15 on page 67.
6	06h	Write failure	Set for any unrecoverable write or positioning error where isolation is uncertain and failure could be due to a faulty tape cartridge or to faulty drive hardware.	If Flag 9 is also set, make sure that the write-protect switch is set so that data can be written to the tape (see "Setting the Write-Protect Switch" on page 50). If Flag 4 is also set, the cartridge is defective. Replace the tape cartridge. If Flag 4 is not set, see error code 6 in Table 15 on page 67.
8	08h	Not data grade	Set when severe servo errors occur while loading a tape cartridge.	Replace the tape cartridge. If this error occurs with multiple tapes, see error code 6 in Table 15 on page 67.
9	09h	Write protect	Set when the tape drive detects that the tape cartridge is write-protected.	Make sure that the cartridge's write-protect switch is set so that the tape drive can write data to the tape (see "Setting the Write-Protect Switch" on page 50).
10	0Ah	No removal	Set when the tape drive receives an UNLOAD command after the server prevented the tape cartridge from being removed.	Refer to the documentation for your server's operating system.

TapeAlert Flags Supported by the IBM TotalStorage LTO Ultrium 2 Tape Drive

Flag Number	Flag Parameter (in hex)	Flag	Description	Action Required
11	0Bh	Cleaning media	Set when you load a cleaning cartridge into the drive.	No action required.
12	0Ch	Unsupported format	Set when you load an unsupported cartridge type into the drive or when the cartridge format has been corrupted.	Use a supported tape cartridge.
15	0Fh	Cartridge memory chip failure	Set when a cartridge memory (CM) failure is detected on the loaded tape cartridge.	Replace the cartridge. If this error occurs on multiple tapes, see error code 6 in Table 15 on page 67.
16	10h	Forced eject	Set when you manually unload the tape cartridge while the drive was reading or writing.	No action required.
18	12h	Tape directory corrupted in the cartridge memory	Set when the drive detects that the tape directory in the cartridge memory has been corrupted.	Re-read all data from the tape to rebuild the tape directory.
20	14h	Clean now	Set when the tape drive detects that it needs cleaning.	Clean the tape drive. See "Cleaning the Drive Head" on page 35.
21	15h	Clean periodic	Set when the drive detects that it needs routine cleaning.	Clean the tape drive as soon as possible. The drive can continue to operate, but you should clean the drive soon. See "Cleaning the Drive Head" on page 35.
22	16h	Expired clean	Set when the tape drive detects a cleaning cartridge that has expired.	Replace the cleaning cartridge.
23	17h	Invalid cleaning tape	Set when the drive expects a cleaning cartridge and the loaded cartridge is not a cleaning cartridge.	Use a valid cleaning cartridge.
30	1Eh	Hardware A	Set when a hardware failure occurs which requires that you reset the tape drive to recover.	If resetting the drive does not recover the error, use the error code from the single-character display, library user interface, or SCSI drive sense data. See Table 15 on page 67.
31	1Fh	Hardware B	Set when the tape drive fails its internal self tests.	Use the error code on the single-character display, library user interface, or SCSI drive sense data. See Table 15 on page 67.
32	20h	Interface	Set when the tape drive detects a problem with the SCSI, Fibre Channel, or LDI (RS-422) interface.	Locate error code 8 or 9 in Table 15 on page 67.
33	21h	Eject media	Set when a failure occurs that requires you to unload the cartridge from the drive.	Unload and reload the tape cartridge.

TapeAlert Flags Supported by the IBM TotalStorage LTO Ultrium 2 Tape Drive				
Flag Number	Flag Parameter (in hex)	Flag	Description	Action Required
34	22h	Download fail	Set when an FMR image is unsuccessfully downloaded to the tape drive via the SCSI or Fibre Channel interface.	Ensure that it is the correct image. Download the FMR image again.
36	24h	Drive temperature	Set when the drive's temperature sensor indicates that the drive's temperature is exceeding the recommended temperature of the enclosure (see Table 4 on page 11).	See error code 1 in Table 15 on page 67.
37	25h	Drive voltage	Set when the drive detects that the externally supplied voltages are either approaching the specified voltage limits or are outside the voltage limits (see Table 4 on page 11).	See error code 2 in Table 15 on page 67.
39	27h	Diagnostics required	Set when the drive detects a failure that requires diagnostics to isolate the problem.	See error code 6 in Table 15 on page 67.
51	33h	Tape directory invalid at unload	Set when the tape directory on the tape cartridge that was previously unloaded is corrupted. The file-search performance is degraded.	Rebuild the tape directory by reading all the data
52	34h	Tape system area write failure	Set when the tape cartridge that was previously unloaded could not write its system area successfully.	Copy the data to another tape cartridge, then discard the old cartridge.
53	35h	Tape system area read failure	Set when the tape system area could not be read successfully at load time.	Copy the data to another tape cartridge, then discard the old cartridge.

Notices

Trademarks

The following are trademarks of International Business Machines Corporation in the United States, or other countries, or both.

AIX	iSeries	SP
AS/400	OS/400	TotalStorage
@server	pSeries	zSeries
IBM	RS/6000	

The following are U.S. trademarks of Hewlett-Packard Company, International Business Machines Corporation, and Seagate Technology.

Linear Tape-Open	Ultrium
LTO	Ultrium Logo
LTO Logo	

Intel is a registered trademark of Intel Corporation in the United States, or other countries, or both.

Microsoft, Windows, Windows NT, Windows 2000, and the Windows logo are registered trademarks of Microsoft Corporation in the United States, or other countries, or both.

Other company, product, or service names may be the trademarks or service marks of others.

Electronic Emission Notices

Special Considerations for Electromagnetic Compatibility

For Class B electromagnetic emissions applications, the IBM TotalStorage LTO Ultrium 2 Tape Drive requires that you install it with a Class B front bezel. Contact IBM for ordering information or for assistance with bezel design requirements for Class B environments. System integrators should refer to the product's functional specification for additional information.

Models T400 and T400F of the IBM TotalStorage LTO Ultrium 2 Tape Drive have been found to satisfy electromagnetic compatibility (EMC) requirements when they are installed in a suitably designed enclosure. Due to the high-performance and high-frequency operation of these drives, your enclosure must have sufficient EMC shielding and filtering for the intended product class (A or B). It is the manufacturer's responsibility to ensure compliance to the required EMC standards by using appropriate testing and certification.

IBM TotalStorage LTO Ultrium 2 Tape Drive Models T400 and T400F

The following statement applies to this product. The statement for other products that are intended for use with this product will appear in their accompanying manuals.

Federal Communications Commission (FCC) Class B Statement

Note: This equipment has been tested and found to comply with the limits for a Class B digital device, pursuant to Part 15 of the FCC Rules. These limits are designed to provide reasonable protection against harmful interference in a residential installation. This equipment generates, uses, and can radiate radio frequency energy and, if not installed and used in accordance with the instructions, may cause harmful interference to radio communications. However, there is no guarantee that interference will not occur in a particular installation. If this equipment does cause harmful interference to radio or television reception, which can be determined by turning the equipment off and on, the user is encouraged to try to correct the interference by one or more of the following measures:

- Reorient or relocate the receiving antenna.
- Increase the separation between the equipment and receiver.
- Connect the equipment into an outlet on a circuit different from that to which the receiver is connected.
- Consult an IBM authorized dealer or service representative for help.

IBM is not responsible for any radio or television interference caused by unauthorized changes or modifications to this equipment. Unauthorized changes or modifications could void the user's authority to operate the equipment.

This device complies with Part 15 of the FCC Rules. Operation is subject to the following two conditions: (1) this device may not cause harmful interference, and (2) this device must accept any interference received, including interference that may cause undesired operation.

Industry Canada Class B Emission Compliance Statement

This Class B digital apparatus complies with Canadian ICES-003.

Avis de conformité à la réglementation d'Industrie Canada

Cet appareil numérique de la classe B est conforme à la norme NMB-003 du Canada.

European Union (EU) Electromagnetic Compatibility Directive

This product has been tested and found to comply with the limits for Class B Information Technology Equipment according to European Standard EN 55022. The limits for Class B equipment were derived for typical residential environments to provide reasonable protection against interference with licensed communication devices.

Germany Electromagnetic Compatibility Directive

Zulassungsbescheinigung laut dem Deutschen Gesetz über die elektromagnetische Verträglichkeit von Geräten (EMVG) vom 30. August 1995 (bzw. der EMC EG Richtlinie 89/336).

Dieses Gerät ist berechtigt, in Übereinstimmung mit dem Deutschen EMVG das EG-Konformitätszeichen - CE - zu führen.

Verantwortlich für die Konformitätserklärung nach Paragraph 5 des EMVG ist die IBM Deutschland Informationssysteme GmbH, 70548 Stuttgart.

Informationen in Hinsicht EMVG Paragraph 3 Abs. (2) 2: Das Gerät erfüllt die Schutzanforderungen nach EN 50082-1 und EN 55022 Klasse B.

EN 50082-1 Hinweis: "Wird dieses Gerät in einer industriellen Umgebung betrieben (wie in EN 50082-2 festgelegt), dann kann es dabei eventuell gestört werden. In solch einem Fall ist der Abstand bzw. die Abschirmung zu der industriellen Störquelle zu vergrößern."

Anmerkung: Um die Einhaltung des EMVG sicherzustellen, sind die Geräte wie in den IBM Handbüchern angegeben zu installieren und zu betreiben.

Japan VCCI Class B ITE Electronic Emission Statement

この装置は、情報処理装置等電波障害自主規制協議会（VCCI）の基準に基づくクラスB情報技術装置です。この装置は、家庭環境で使用することを目的としていますが、この装置がラジオやテレビジョン受信機に近接して使用されると、受信障害を引き起こすことがあります。
取扱説明書に従って正しい取り扱いをして下さい。

vcci-b

Getting Help

If you need assistance while installing or operating your IBM TotalStorage LTO Ultrium 2 Tape Drive, contact your OEM Product Application Engineer (PAE).

Warranty

The warranty for this product is negotiated on a per-customer basis.

Glossary

This glossary defines the special terms, abbreviations, and acronyms that are used in this publication.

Numbers and Symbols

2:1 compression. The relationship between the quantity of data that can be stored with compression as compared to the quantity of data that can be stored without compression. In 2:1 compression, twice as much data can be stored with compression as can be stored without compression.

µs. Abbreviation for microsecond or one millionth of a second (.000001 s).

A

A. See *ampere*.

acclimation time. Pertaining to the Ultrium 2 Tape Drive, the amount of time that is needed for the drive to adjust to change in temperature, altitude, climate, or environment.

active. The condition that the SCSI bus is in when a server is trying to use one or more devices on the bus.

adapter. See *adapter card*.

adapter card. A circuit board that adds function to a computer.

AL_PA. See *Arbitrated Loop Physical Address*.

amp. See *ampere*.

ampere (A, amp). A unit of measure for electric current that is equivalent to a flow of one coulomb per second, or equivalent to the current produced by one volt applied across a resistance of one ohm.

American National Standards Institute. A private, non-profit organization that gathers and disseminates information about standards and conformity issues that affect the business, government, and people of the United States.

ANSI. See *American National Standards Institute*.

Arbitrated Loop Physical Address (AL_PA). An 8-bit value that identifies a device in an arbitrated loop. All Fibre Channel ports communicate by using AL_PAs.

autosense data. Sent by the drive to the server, sense data that automatically accompanies a Check Condition in response to an error. The server does not need to send a REQUEST SENSE command to get the

sense data. Autosense data is available only in the Fibre Channel version of the Ultrium 2 Tape Drive (Model T400F).

B

backhitch. During tape movement (reading or writing), the condition that occurs when the tape drive must stop the tape, reverse it, and restart tape motion due to certain events. A backhitch usually occurs when the server's net (compressed) data rate is less than the drive's data rate.

backreflection. Pertaining to instances where light is launched into an optical fiber in a forward direction, the light that is returned to the launch point in the reverse direction.

backups. The short-term retention of records used for restoring essential business and server files when vital data has been lost because of program or server errors or malfunctions.

backward compatible. Capable of being used with a previous product that was designed for a similar purpose. For example, a tape cartridge that is designed to be used with a modern tape drive but can also be used with certain older tape drives. Synonymous with *downward compatible*.

bar code. A code that represents characters by sets of parallel bars of varying thickness and separation. The bars are read optically by transverse scanning.

bar code label. A slip of paper bearing a bar code and having an adhesive backing. The bar code label must be affixed to a tape cartridge to enable the library to identify the cartridge and its volume serial number.

bezel. The removable frame that fits over the front of the Ultrium 2 Tape Drive.

bit. The smallest unit of data in a computer. A bit (short for binary digit) has a single binary value (either 0 or 1). Computers store data and execute instructions in bit multiples called bytes. In most computer systems, there are eight bits in a byte.

burst data transfer rate. The maximum speed at which data is transferred.

bus. See *SCSI bus*.

byte. A string that consists of a certain number of bits (usually 8) which are treated as a unit and represent a character. A byte is a fundamental unit of data.

C

C. See *Celsius*.

capacity. The amount of data that can be contained on storage media and expressed in bytes.

cartridge. See *tape cartridge*.

cartridge door. On a tape cartridge, the hinged barrier that can be opened to access, or closed to protect, the magnetic tape within the cartridge.

cartridge manual rewind tool. A device that can be fitted into the reel of a cartridge and used to rewind tape into or out of the cartridge.

cartridge memory. See *LTO cartridge memory*.

Celsius. Having a thermometric scale on which the interval between the freezing point and the boiling point of water is divided into 100 degrees, with 0° representing the freezing point and 100° representing the boiling point.

channel calibration. A feature of the Ultrium 2 Tape Drive by which it automatically customizes each read/write data channel to compensate for variations in such things as the recording channel's transfer function, the media, and characteristics of the drive head. Channel calibration optimizes system performance.

circuit board. A thin sheet on which chips and other electronic components are placed. Computers consist of one or more boards, often called cards or adapters.

cleaning cartridge. A tape cartridge that is used to clean the heads of a tape drive. Contrast with *data cartridge*.

clockwise. In the direction that the hands of a clock rotate, as viewed from the front.

command time-out. Following the issuance of a command, a period of time during which it is determined that there is a bad connection between the server and the drive.

compression. The process of eliminating gaps, empty fields, redundancies, and unnecessary data to shorten the length of records or blocks.

configure. To describe to a server the devices, optional features, and programs installed on the system.

contiguous. Touching along a boundary or at a point.

core. The light-conducting central portion of an optical fiber. The core is composed of material that has a higher index of refraction than the cladding (the material that surrounds the core).

counterclockwise. In a direction opposite to that in which the hands of a clock rotate, as viewed from the front.

current. The quantity of charge per unit of time. Current is measured in amperes.

cycle power. To apply and remove electrical power to a device within a short time span.

D

data. Any representations such as characters or analog quantities to which meaning is, or might be, assigned.

data cartridge. A tape cartridge that is dedicated to storing data. Contrast with *cleaning cartridge*.

data compression. See *compression*.

data transfer rate. The average number of bits, characters, or blocks per unit of time that pass between corresponding equipment in a data transmission system. The rate is expressed in bits, characters, or blocks per second, minute, or hour.

dc. Direct current.

degauss. To make a magnetic tape nonmagnetic by exposing the tape to electrical coils which carry currents that neutralize the magnetism of the tape.

device. Any hardware component or peripheral, such as a tape drive or tape library, that can receive and send data.

device driver. A file that contains the firmware that is needed to use an attached device.

diagnostic. A software program that is designed to recognize, locate, and explain faults in equipment or errors in programs.

diagnostic cartridge. A tape cartridge that enables the detection and isolation of errors in programs and faults in equipment.

direct current (dc). An electric current flowing in one direction only and substantially constant in value.

director-class switch. A high-end switch that includes such qualities as fault tolerance, high throughput, high reliability, port density, and so forth.

drive. See *IBM TotalStorage LTO Ultrium 2 Tape Drive*.

drive dump. The recording, at a particular instant, of the contents of all or part of one storage device into another storage device, usually as a safeguard against faults or errors, or in connection with debugging.

drive head. The component that records an electrical signal onto magnetic tape, or reads a signal from tape into an electrical signal.

drive sense data. See *SCSI drive sense data*.

dump. See *drive dump*.

duplex. See *duplex transmission*.

duplex adapter. A mechanism that allows a device to send and receive communication at the same time.

duplex transmission. Transmission in both directions, either one direction at a time (half-duplex) or both directions simultaneously (full-duplex).

E

eject. To remove or force out from within.

electronic mail. Correspondence in the form of messages transmitted between user terminals over a computer network.

e-mail. See *electronic mail*.

enclosure. A device, such as a desktop unit, tape cartridge autoloader, or tape library, into which you can install the Ultrium 2 Tape Drive.

error log. Maintained by the Ultrium 2 Tape Drive, a list that contains the ten most recent error codes. The codes identify errors that pertain to the drive.

F

fabric. A Fibre Channel entity which interconnects and facilitates logins of N_ports that attach to it. The fabric is responsible for routing frames between source and destination N_ports by using address information in the frame header. A fabric can be as simple as a point-to-point channel between two N_ports, or as complex as a frame-routing switch that provides multiple and redundant internal pathways within the fabric between F_ports.

fan shroud. The wire mesh enclosure around the fan that holds it in place and prevents direct access. The shroud mounts the fan assembly to the Ultrium 2 Tape Drive. generic FC reference to an N_port or an F_port.

FC-AL. See *Fibre Channel-Arbitrated Loop*.

FC port. See *Fibre Channel port*.

feature switch. Located under the Ultrium 2 Tape Drive, a bank of eight micro switches that can be manually toggled on or off to activate or deactivate different characteristics of the drive.

fiber optic cable. The medium by which light is transmitted through fibers or thin rods of glass or some other transparent material of high refractive index.

fiber optics. A branch of optics dealing with the transmission of light through fibers or thin rods of glass or some other transparent material of high refractive index.

Fibre Channel. A 100-MB-per-second, full-duplex, serial communications technology that is capable of interconnecting Ultrium 2 Tape Drives and servers which are separated by as much as 11 kilometers (7 miles). Fibre Channel technology combines features of the input/output (I/O) and networking interfaces.

Fibre Channel address. For a tape drive that uses a Fibre Channel interface, an identifier (such as an AL_PA or Loop ID) that enables other device ports to communicate with that drive. A Fibre Channel drive has a 3-byte address. The switch assigns the upper 2 bytes of the address. If no switch is attached, the 2 bytes equal 0. The lower byte assignment (which is the AL_PA) varies, depending on whether hard or soft addressing is used.

Fibre Channel-Arbitrated Loop (FC-AL) topology. A serial data-transfer architecture and standard governed by ANSI. FC-AL is designed for mass storage devices and other peripheral devices that require high bandwidth. By using optical fiber to connect devices, FC-AL supports full-duplex data transfer rates of 100MBps. An FC-AL topology is compatible with a SCSI interface for high-performance storage systems.

Fibre Channel cable. The cable that connects a Fibre Channel tape drive to another device. The conductive element within the cable is constructed of either copper wires or optical fibers. Generally, copper wires are used for short distances (up to 30 meters or 98 feet); optical fibers are used for longer distances. Fiber-optic cabling is referred to by mode or the frequencies of light waves that are carried by a particular cable type. Multimode fiber cables are generally used for distances up to 500 meters (1640 feet) and with short-wave (780 nanometer) laser light. Single-mode fiber cables are used for distances greater than 500 m (1640 feet) and with long-wave (1300 nanometer) laser light.

Fibre Channel configuration/status connector. Located at the rear of a Fibre Channel drive, the connector that allows you to optionally change the drive's link services (for example, its speed and type of topology).

Fibre Channel interface. The hardware or software that links differing Fibre Channel systems, programs or devices.

Fibre Channel port. A generic Fibre Channel reference to an N_port or an F_port.

Fibre Channel protocol. An evolving ANSI interconnection standard for high-speed data transfer among computers and storage devices defined by the Fibre Channel Protocol (FCP). At the physical level, data is transmitted serially over pairs of point-to-point links between FC ports. With appropriate components, data can be transferred at 100 MB/sec up over a distance of 10 km between FC ports. The ports can be configured in ring and switched interconnect topologies which allow each port to exchange data with any other port that is part of the same fabric.

Fibre Channel wrap test. A diagnostic that causes the Ultrium 2 Tape Drive to perform a check of the Fibre Channel circuitry from and to the drive's Fibre Channel connector or the fiber cable.

field microcode replacement tape. A tape cartridge that contains new or revised firmware (microcode) for the Ultrium 2 Tape Drive.

file. A named set of records that are stored or processed as a unit.

filemark. Located on the magnetic tape within a tape cartridge, a recorded element that typically marks the organizational boundaries in a serial file structure (such as directory boundaries) and that is requested to be written or read by the server.

firmware. The proprietary code that is usually delivered as part of an operating system. Firmware is more efficient than software that is loaded from an alterable medium, and is more adaptable to change than pure hardware circuitry. An example of firmware is the Basic Input/Output System (BIOS) in read-only memory (ROM) on a PC motherboard.

FMR tape. See *field microcode replacement tape*.

foot. A unit of length comprising 12 inches.

G

Gb. See *gigabit*.

GB. See *gigabyte*.

Generation 1. The informal name for the IBM Ultrium Internal Tape Drive, which is the predecessor of the Ultrium 2 Tape Drive (Generation 2). The Generation 1 drive has a native storage capacity of up to 100 GB per cartridge and a native sustained data transfer rate of 15 MB per second.

Generation 2. The informal name for the Ultrium 2 Tape Drive, which is the second-generation version of the IBM Ultrium Internal Tape Drive (Generation 1). The Generation 2 drive has a native storage capacity of up to 200 GB per cartridge and a native sustained data transfer rate of 35 MB per second.

gigabit (Gb). 1 000 000 000 bits. 1 Gb equals 100 MB.

gigabyte (GB). 1 000 000 000 bytes.

ground. An object that makes an electrical connection with the earth.

H

hard addressing. Pertaining to the Fibre Channel drive (Model T400F), a method that identifies the drive's LID and, consequently, its AL_PA (the AL_PA enables the drive to communicate with other devices).

hardware. The physical equipment or devices that form a computer.

head. See *drive head*.

Head Resistance Measurements test. Part of the Test Head diagnostic, a procedure that determines whether the tape drive's head works correctly. The test measures the head's ability to withstand cracks and other defects.

host. The controlling or highest-level system in a data communication configuration. Synonymous with *server*.

hot-pluggable. Pertaining to the Ultrium 2 Tape Drive, the ability to remove the drive from an enclosure while the enclosure is powered-on.

hub. A communications device to which nodes on a multi-point bus or loop are physically connected. Hubs are commonly used in Fibre Channel networks to improve the manageability of physical cables. They maintain the logical loop topology of the network of which they are a part, while creating a "hub and spoke" physical star layout. Unlike switches, hubs do not aggregate bandwidth. They typically support the addition or removal of nodes from the bus while it is operating.

I

IBM TotalStorage LTO Ultrium 2 Tape Drive. A data-storage device that controls the movement of the magnetic tape in an IBM LTO Ultrium Tape Cartridge. The drive houses the mechanism (drive head) that reads and writes data to the tape. The drive is the first of four drives planned for the Ultrium format. Its native data capacity is 100 GB per cartridge; with 2:1 compression, its capacity is up to 200 GB.

ID. Identifier.

in. See *inch*.

inch. A unit of length equal to 1/36 yard or 25.4 mm.

initiator. In SCSI terms, a SCSI device that requests an I/O process to be performed by another SCSI device (a target). In many cases, an initiator can also be a target.

input/output (I/O). Data that is provided to a computer or data that results from computer processing.

insertion guide. On the surface of the IBM LTO Ultrium Tape Cartridge, a large, notched area that prevents you from inserting the cartridge incorrectly.

install. (1) To set up for use or service. (2) The act of adding a product, feature, or function to a server or device either by a singular change or by the addition of multiple components or devices.

Internet. The worldwide collection of interconnected networks that use the Internet suite of protocols and permit public access.

interposer. An adapter-like device that allows a connector of one size and style to connect to a mating connector of a different size and style. Data provided to the computer or data resulting from computer processing.

I/O. See *input/output*.

J

J2 connector. Located at the rear of the Ultrium 2 Tape Drive, the connector for the LDI (or RS-422) interface.

J33 connector. Located at the rear of the Ultrium 2 Tape Drive, a single connector that contains the connections for the SCSI signals and grounds, SCSI ID, SCSI bus termination, and drive power.

jumper. (1) A tiny connector that fits over a pair of protruding pins in a connector. A jumper can be moved to change electrical connectors. When in place, the jumper connects the pins electrically. (2) To place a jumper on a connector pin.

L

label. A slip of paper with an adhesive backing that can be written on and affixed to a tape cartridge as a means of identification or description.

label area. On the LTO Ultrium Tape Cartridge, a recessed area next to the write-protect switch where a bar code label must be affixed.

LAN. See *local area network*.

LDI. See *Library/Drive Interface*.

leader-pin block. Located within the Ultrium 2 Tape Drive, the part that engages the steel pin which is attached to the tape in an LTO Ultrium Tape Cartridge. Once engaged, the leader-pin block pulls the tape from the cartridge into the drive.

leader pin. On the LTO Ultrium Tape Cartridge, a small metal column that is attached to the end of the magnetic tape. During tape processing the leader pin is grasped by a threading mechanism, which pulls the pin and the tape out of the cartridge, across the drive head, and onto a takeup reel. The head can then read or write data from or to the tape.

LED. See *light-emitting diode*.

Library/Drive Interface. An electrical interface standard that is approved by the Electronic Industries Association (EIA) for connecting serial devices.

Library/Drive Interface (LDI) connector. Located at the rear of the Ultrium 2 Tape Drive, the connector to which the internal LDI cable of an enclosure connects. The connection enables serial devices to communicate with the drive.

LID. See *loop identifier*.

LID/status connector. See *loop identifier (LID)/status connector*.

link services. The speed and topology of your Fibre Channel drive. If you choose not to alter the link services, the drive defaults to a negotiated speed and operation in an FC-AL topology with a direct connection to the server.

LIP. See *loop initialization protocol*.

light-emitting diode (LED). A semiconductor diode that emits light when subjected to an applied voltage and that is used in an electronic display.

Linear Tape-Open (LTO). A type of tape storage technology developed by the IBM Corporation, Hewlett-Packard, and Seagate. LTO technology is an "open format" technology, which means that its users have multiple sources of product and media. The "open" nature of LTO technology enables compatibility between different vendors' offerings by ensuring that vendors comply with verification standards.

load. Following the insertion of a tape cartridge into the tape load compartment, the act of positioning the tape (performed by the tape drive) for reading or writing by the drive's head.

load and unload cycle. The act of inserting a cartridge into a tape drive, loading the tape to load point, rewinding the tape into the cartridge, and ejecting the cartridge from the drive.

local area network (LAN). A computer network that is located on a user's premises within a limited geographical area. The network consists of a set of devices that are connected to one another for communication and that can be connected to a larger network. Communications are limited to a

moderate-sized geographic area (1 to 10 km) such as a single office building, warehouse, or campus.

log sense data. See *SCSI log sense data*.

loop. (1) A series of instructions that is repeated until a terminating condition is reached. (2) To connect so as to complete a loop.

loop ID. See *loop identifier*.

loop identifier (LID). In a Fibre Channel topology, the identifier that a device assigns to an Ultrium 2 Tape Drive. An operator uses the LID to set the AL_PA.

loop identifier (LID)/status connector. Located on the Model T400F, the connector that is used to set the Loop ID and provide status about the loop.

loop initialization protocol (LIP). A method by which a device in a Fibre Channel Arbitrated Loop acquires its AL_PA.

loss. In fiber optics technology, the amount of a signal's power (expressed in dB) that is lost in connectors, splices, or fiber defects.

Low Voltage Differential (LVD). A low-noise, low-power, and low-amplitude electrical signaling system that enables data communication between a supported server and the Ultrium 2 Tape Drive. LVD signaling uses two wires to drive one signal over copper wire. The use of wire pairs reduces electrical noise and crosstalk.

L_port. Located on the Ultrium 2 Tape Drive, the Fibre Channel portal that facilitates communication only in an FC-AL topology. An L_port also allows connection to FL_ports and NL_ports.

LTO. See *Linear Tape-Open*.

LTO cartridge memory (LTO-CM). Within each LTO Ultrium Data Cartridge, an embedded electronics and interface module that can store and retrieve a cartridge's historical usage and other information.

LTO-CM. See *LTO cartridge memory*.

LTO-DC. See *LTO Data Compression*.

LTO Data Compression (LTO-DC). A method that compresses a server's data before the drive writes it to tape. LTO-DC detects but does not recompress or test record boundaries and file markers (which are encoded as control symbols). It also allows switching between compression and no compression within the data stream, which prevents data from expanding when the drive compresses random or encrypted data.

LVD. See *Low Voltage Differential*.

M

m. See *meter*.

magnetic tape. A tape with a magnetizable surface layer on which data can be stored by magnetic recording.

maintenance mode. The state of operation in which the Ultrium 2 Tape Drive must be before it can run diagnostics, verify write and read operations, verify a suspect tape cartridge, update its own firmware, and perform other diagnostic and maintenance functions.

MB. See *megabyte*.

media. The plural of *medium*.

media capacity. See *capacity*.

medium. A physical material in or on which data may be represented, such as magnetic tape.

megabyte (MB). 1 000 000 bytes.

metal particle tape. In the LTO Ultrium Tape Cartridge, tape that uses very small, pure metal particles (rather than oxide coatings) in the magnetic layer.

meter. In the Metric System, the basic unit of length; equal to approximately 39.37 inches.

micrometer. One millionth of a meter (.000001 m). Synonymous with *micron*. Abbreviated as μm .

micron. One millionth of a meter (.000001 m). Synonymous with *micrometer*. Abbreviated as μm .

microsecond. One millionth of a second (.000001 s). Abbreviated as μs .

millimeter (mm). One thousandth of a meter (.001 m).

millisecond (ms). One thousandth of a second (.001 s).

mm. See *millimeter*.

Model T400. The version of the IBM TotalStorage LTO Ultrium 2 Tape Drive that uses the SCSI interface.

Model T400F. The version of the IBM TotalStorage LTO Ultrium 2 Tape Drive that uses the Fibre Channel interface.

ms. See *millisecond*.

multimode fiber. An optical fiber that has a core that is large enough to propagate more than one electromagnetic wave of light. The typical diameter is 62.5 micrometers.

N

N/A. Not applicable.

native storage capacity. The amount of data that can be stored without compression on a tape cartridge.

native sustained data transfer rate. See *data transfer rate*.

negotiated speed. Defined by Fibre Channel Standards, the algorithm that ensures the highest speed that is supported by both the Ultrium 2 Tape Drive and the port to which it attaches. This negotiation occurs at power up and whenever a catastrophic link event occurs, such as a cable pull that exceeds the timeouts that are specified in the Standards. The speed is negotiated when the first possibility of a new connection (for example, a fiber cable) is established, and is maintained until the Fibre Channel connection is terminated. The speed is not renegotiated when a new device is attached to a loop.

network. A configuration of data processing devices and software that is connected for information interchange.

network server. In a local area network, a personal computer that provides access to files for all of the workstations in the network.

node. In Fibre Channel technology, a communicating device.

N_port. Located on the Ultrium 2 Tape Drive, the Fibre Channel portal that facilitates communication only in a point-to-point topology. An N_port also allows connection to F_ports.

NL_port. Located on the Ultrium 2 Tape Drive, the Fibre Channel portal that facilitates communication only in a point-to-point topology (by acting as an N_port). If the connection fails, the port attempts to connect in an FC-AL topology (by acting as an L_port).

ntutil. Created by IBM, a utility program for LTO devices that connect to Windows NT and Windows 2000. *ntutil* provides problem determination for hardware or connections, assists with device and medium changer recognition, forces dumps, loads new firmware, sends and receives SCSI commands to and from the hardware, and obtains SCSI sense data to use in resolving errors.

O

oersted. The unit of magnetic field strength in the unrationalized centimeter-gram-second (cgs) electromagnetic system. The oersted is the magnetic field strength in the interior of an elongated, uniformly

wound solenoid that is excited with a linear current density in its winding of one abampere per 4π centimeters of axial length.

offline. The operating condition that the Ultrium 2 Tape Drive is in when the server's applications cannot interact with it.

online. The operating condition that the Ultrium 2 Tape Drive is in when the server's applications can interact with it.

Open Systems. Computer systems whose standards are not proprietary.

operating environment. The temperature, relative humidity rate, and wet bulb temperature of the room in which the Ultrium 2 Tape Drive routinely conducts processing.

operating system. The master computer control program that translates the user's commands and allows software application programs to interact with the computer's hardware.

optical transceiver. A device that both transmits and receives analog or digital signals over a light source.

P

panic reset. The act of pressing and holding the unload button for 10 seconds to force a reset of a nonresponsive drive.

parity. The state of being even-numbered or odd-numbered. A parity bit is a binary number that is added to a group of binary numbers to make the sum of that group always odd (odd parity) or even (even parity).

parity error. A transmission error that occurs when the received data does not have the parity that is expected by the receiving system. This usually occurs when the sending and receiving systems have different parity settings.

point-to-point connection. Pertaining to data transmission between two locations without the use of any intermediate display station or computer.

port. (1) A system or network access point for data entry or exit. (2) A connector on a device to which cables for other devices such as display stations and printers are attached. (3) The representation of a physical connection to hardware. A port is sometimes referred to as an adapter; however, there can be more than one port on an adapter.

power connector. Located at the rear of the Ultrium 2 Tape Drive, the connector to which the internal power cable of an enclosure connects.

power cord. A cable that connects a device to a source of electrical power.

power-off. To remove electrical power from a device.

power-on, powered-on. (1) To apply electrical power to a device. (2) The state of a device when power has been applied to it.

private device. A device that is attached directly to a server and is not connected to a fabric or switch. A private device can be part of an arbitrated loop topology or point-to-point topology.

protocol. The meanings of, and the sequencing rules for, requests and responses that are used to manage a network, transfer data, and synchronize the states of network components.

public device. A device that is attached to a fabric or switch, and can communicate to that fabric or switch. A public device can be part of an arbitrated loop topology or point-to-point topology.

Q

quiesce. To put a device into a temporarily inactive or inhibited state, but not remove it from the server.

R

read. To acquire or interpret data from a storage device, from a data medium, or from another source.

reboot. To reinitialize the execution of a program by repeating the initial program load (IPL) operation.

record. The smallest distinct set of data bytes that is supplied from a server for processing and recording by a tape drive, and the smallest distinct set of data to be read from tape, reprocessed, and made available to a server by a tape drive.

record boundaries. The fixed limits of a record.

relative humidity. The ratio of the amount of water vapor actually present in the air to the greatest amount possible at the same temperature.

repeater. A device that regenerates signals to extend the range of transmission between data stations or to interconnect two branches. A repeater is a node of a local area network.

reset. To return a device or circuit to a clear state.

LDI wrap plug. A connector mechanism that connects to an LDI port for the purpose of testing the Ultrium 2 Tape Drive's circuitry for the LDI interface.

LDI wrap test. A diagnostic that can be run on the Ultrium 2 Tape Drive to determine whether the circuitry functions properly to and from the LDI connector.

S

s. See *second*.

SAN. See *Storage Area Network*.

SAN Data Gateway. A device that provides Fibre Channel attachment between Open Systems servers and SCSI disk and tape storage systems.

SC. See *subscription channel connector*.

scratch cartridge. A data cartridge that contains no useful data, but can be written to with new data.

SCSI. See *Small Computer Systems Interface*.

SCSI bus. (1) A collection of wires through which data is transmitted from one part of a computer to another. (2) A generic term that refers to the complete set of signals that define the activity of the Small Computer Systems Interface (SCSI).

SCSI connector. Located at the rear of the Ultrium 2 Tape Drive, the connector that facilitates commands to and from the server, and to which the internal SCSI cable of an enclosure connects.

SCSI device. Anything that can connect into the SCSI bus and actively participate in bus activity.

SCSI drive sense data. In response to inquiry from the server about an error condition, a packet of SCSI sense bytes that contains information about the error and that is sent back to the server by the drive.

SCSI ID. The unique address (from 1 to 15) that you assign to an Ultrium 2 Tape Drive that uses a SCSI interface (Model T400).

SCSI ID connector. Located at the rear of the Ultrium 2 Tape Drive, the connector that enables the drive's SCSI address to be set. Addresses are determined by the placement of jumpers on the pins.

SCSI interface. See *Small Computer Systems Interface*.

SCSI protocol. A set of rules that control the communication and transfer of data between two or more SCSI devices or systems in a communications network.

SCSI ID switch. Located on an enclosure that contains a Ultrium 2 Tape Drive, a mechanism that connects to the drive and allows you to change the drive's SCSI ID without using jumpers.

SCSI log sense data. In response to inquiry from the server about the Ultrium 2 Tape Drive's error logs and counters, a packet of SCSI sense bytes which contains that information and which is sent back to the server by

the drive. Log sense data is used to diagnose problems, especially if the problems are intermittent.

SCSI wrap plug. A connector mechanism that connects to a SCSI port for the purpose of testing the Ultrium 2 Tape Drive's circuitry for the SCSI interface.

SCSI wrap test. A diagnostic that can be run on the Ultrium 2 Tape Drive to determine whether the circuitry functions properly to and from the SCSI connector.

second. One sixtieth of a minute.

selection time-out. Following the selection of an option (for example, a data transfer), the period of time during which it is determined that there is a bad connection between the server and the drive.

sense data. Data that describes an I/O error. Sense data is presented to a server in response to a Sense I/O command.

serial interface. An interface that sequentially or consecutively executes two or more operations in a single device, such as an arithmetic and logic operation.

server. A functional unit that provides services to one or more clients over a network. Examples include a file server, a print server, or a mail server. The IBM @server pSeries, IBM @server iSeries, HP, and Sun are servers. Synonymous with *host*.

ship group. The group of supplies, cords, or documentation that is shipped with the Ultrium 2 Tape Drive.

shipping environment. The temperature, relative humidity rate, and wet bulb temperature of the environment to which the Ultrium 2 Tape Drive is exposed when it is transferred from one location to another.

short-wave cable. In Fibre Channel technology, a laser cable that uses a wavelength of 780 nanometers and is only compatible with multimode fiber.

single-character display. Located at the front of the Ultrium 2 Tape Drive, an LED that presents an alphabetical or numeric code which represents a diagnostic or maintenance function, error condition, or informational message.

sleep mode. A power-management function that causes the Ultrium 2 Tape Drive's electronics to automatically enter a low-power mode by which to conserve energy.

Small Computer Systems Interface (SCSI). A standard used by computer manufacturers for attaching peripheral devices (such as tape drives, hard disks, CD-ROM players, printers, and scanners) to computers (servers). Pronounced "scuzzy." Variations of the SCSI interface provide for faster data transmission rates than

standard serial and parallel ports (up to 160 megabytes per second). The variations include:

- **Fast/Wide SCSI:** Uses a 16-bit bus, and supports data rates of up to 20 MBps.
- **SCSI-1:** Uses an 8-bit bus, and supports data rates of 4 MBps.
- **SCSI-2:** Same as SCSI-1, but uses a 50-pin connector instead of a 25-pin connector, and supports multiple devices.
- **Ultra SCSI:** Uses an 8- or 16-bit bus, and supports data rates of 20 or 40 MBps.
- **Ultra2 SCSI:** Uses an 8- or 16-bit bus and supports data rates of 40 or 80 MBps.
- **Ultra3 SCSI:** Uses a 16-bit bus and supports data rates of 80 or 160 MBps.
- **Ultra160 SCSI:** Uses a 16-bit bus and supports data rates of 160 MBps.

soft addressing. Pertaining to the Fibre Channel drive (Model T400F), a method that enables the drive to dynamically arbitrate its AL_PA with other Fibre Channel devices on the loop. The AL_PA enables the drive to communicate with other devices.

software. Programs, procedures, rules, and any associated documentation pertaining to the operation of a computer system.

speed matching. A technique used by the Ultrium 2 Tape Drive to dynamically adjust its native (uncompressed) data rate to the slower data rate of a server. Speed matching improves system performance and reduces backhitch.

status light. Located at the front of the Ultrium 2 Tape Drive, an LED that can be green or amber, and (when lit) solid or flashing. The condition of the light represents the state of the drive.

Storage Area Network (SAN). A high-speed subnetwork of shared storage devices. A SAN's architecture makes all storage devices available to all servers on a LAN or WAN. As more storage devices are added to a SAN, they too will be accessible from any server in the larger network. Because stored data does not reside directly on any of a network's servers, server power is used for business applications, and network capacity is released to the end user.

storage environment. The temperature, relative humidity rate, and wet bulb temperature of the environment in which the Ultrium 2 Tape Drive is nonoperational and is being kept for future use.

subscription channel connector (SC). A push-pull type of optical connector that features high density, low loss, low backreflection, and low cost.

switch. A network infrastructure component to which multiple nodes attach. Unlike hubs, switches typically have the ability to switch node connections from one to

another. A typical switch can facilitate several simultaneous bandwidth transmissions between different pairs of nodes.

T

TapeAlert. A patented technology and ANSI standard that defines conditions and problems that are experienced by tape drives.

TapeAlert flags. Status and error messages that are generated by the TapeAlert utility and display on the server's console.

tape cartridge. A removable storage case that houses belt-driven magnetic tape that is wound on a supply reel and a takeup reel.

tape drive. See *IBM TotalStorage LTO Ultrium 2 Tape Drive*.

tape path. Within a tape drive, the channel in which the media moves.

tapeutil. Created by IBM, a utility program for LTO devices that connect to all supported servers except Windows NT and Windows 2000. *tapeutil* provides service aids for tape subsystems, offers a menu-driven tool for exercising or testing IBM tape and medium changer devices, and includes a command-line interface that is convenient for use in shell scripts.

terminate. To prevent unwanted electrical signal reflections by applying a device (known as a terminator) that absorbs the energy from the transmission line.

terminator. (1) A part that is used to end a SCSI bus. (2) A single-port, 75- Ω device that is used to absorb energy from a transmission line. Terminators prevent energy from reflecting back into a cable plant by absorbing the radio frequency signals. A terminator is usually shielded, which prevents unwanted signals from entering or valid signals from leaving the cable system.

TERMPOWER. Electrical power that is provided by a device (such as the Ultrium 2 Tape Drive) to a SCSI terminator so that the SCSI bus can function. To supply TERMPower, a jumper must be placed on pin 1 of the SCSI ID connector on the Ultrium 2 Tape Drive.

Test Head diagnostic. A test that determines whether the heads of the Ultrium 2 Tape Drive are operating properly and whether the drive can correctly read from and write to tape.

throughput. A measure of the amount of information that is transmitted over a network in a given period of time.

topology. In communications, the physical or logical arrangement of nodes in a network, especially the relationships among nodes and the links between them.

TotalStorage LTO Ultrium 2 Tape Drive. See *IBM TotalStorage LTO Ultrium 2 Tape Drive*.

track. A linear or angled pattern of data that is written on a tape surface.

transfer rate. See *data transfer rate*.

two-node arbitrated loop. In Fibre Channel technology, the connection of two nodes that communicate directly (without the use of a switch) and use the same protocol.

two-node switched fabric loop. In Fibre Channel technology, the connection of two or more nodes that communicate by using a switch. The nodes may not use the same protocol.

U

Ultra160 LVD SCSI interface. See *Small Computer Systems Interface*.

Ultrium 2 Tape Drive. See *IBM TotalStorage LTO Ultrium 2 Tape Drive*.

uniform resource locator (URL). The address of an item on the World Wide Web. It includes the protocol followed by the fully qualified domain name (sometimes called the host name) and the request. The web server typically maps the request portion of the URL to a path and file name. For example, if the URL is `http://www.networking.ibm.com/nsg/nsgmain.htm`, the protocol is `http`; the fully qualified domain name is `www.networking.ibm.com`; and the request is `/nsg/nsgmain.htm`.

unload. The act (performed by the drive) of unthreading tape from the drive's internal tape path and returning it (with the leader block) to the tape cartridge.

unload button. Located at the front of the Ultrium 2 Tape Drive, a push button that, when depressed, rewinds the tape in a cartridge and ejects the cartridge from the drive. The unload button can also be used to place the tape drive in maintenance mode, scroll through maintenance functions, exit maintenance mode, force a drive dump, and reset the drive.

URL. See *uniform resource locator*.

utility. See *utility program*.

utility program. A computer program that supports computer processes. For example, a diagnostic program, a trace program, or a sort program.

V

Vdc. Volts dc (direct current).

vital product data (VPD). Information about a product. Among other details, the VPD may include a model number, serial number, part number, or level of firmware.

volt. The SI (international) unit of potential difference and electromotive force. Formally defined as the difference of electric potential between two points of a conductor that carries a constant current of one ampere when the power dissipated between these points is equal to one watt.

VPD. Vital product data.

W

W. Watts.

WAN. See *wide area network*.

watt. The metric unit of power that is required to do work at the rate of one joule per second.

web. See *World Wide Web*.

wet bulb temperature. The temperature at which pure water must be evaporated adiabatically at constant pressure into a given sample of air in order to saturate the air under steady-state conditions. Wet bulb temperature is read from a wet bulb thermometer.

wide area network (WAN). A data communications network that is designed to serve an area of hundreds or thousands of miles (for example, national telephone networks).

World Wide Node Name. A unique, 8-byte identifier that is assigned by IBM Manufacturing to each Ultrium 2 Tape Drive and used to identify the drive's SCSI logical unit.

World Wide Port Name. A unique, 8-byte identifier that is assigned by IBM Manufacturing to each Ultrium 2 Tape Drive and used to identify the physical port on the drive.

World Wide Web. A network of servers that contain programs and files. Many of the files contain hypertext links to other documents that are available through the network.

write. To make a permanent or transient recording of data in a storage device or on a data medium.

write protected. Applicable to a tape cartridge, the condition that exists when some logical or physical mechanism prevents a device from writing on the tape in that cartridge.

write-protect switch. Located on the LTO Ultrium Tape Cartridge, a switch that prevents accidental erasure of data. Pictures of a locked and unlocked padlock appear on the switch. When you slide the

switch to the locked padlock, data cannot be written to the tape. When you slide the switch to the unlocked padlock, data can be written to the tape.

Write/Read test. Part of the Test Head diagnostic, a procedure that determines whether the Ultrium 2 Tape Drive can correctly read from and write to tape.

Z

zoning. In Fibre Channel environments, the grouping of multiple ports to form a virtual, private, storage network. Ports that are members of a zone can communicate with each other, but are isolated from ports in other zones.

Index

A

acclimating the drive 16, 52, 53
address
 for Fibre Channel drive 7, 19
 for SCSI drive 5, 17
AIX 3
AL_PA
 description 7, 19
 setting to add LIDs 22
 setting to get status of loop 20
altitude specification 11
Arbitrated Loop Physical Address (AL_PA)
 description 19
 setting to add LIDs 22
 setting to get status of loop 20
AS/400
 device driver support 9
 obtaining error information from 71
 supported server and operating system 3
attaching leader pin to tape, procedure 55
attention notice, definition vii

B

backhitch, preventing 2
bar code label
 ordering 63, 64
 placement on cartridge 48
burst data transfer rate 1
bus, connecting tape drive to SCSI 28

C

cables
 for Fibre Channel 8, 95
 for SCSI 4, 95
capacity 1, 2, 48
cartridge capacity, controlling 48
cartridge door 47
cartridge memory 47, 48
caution notice, definition vii
changing link services 24
channel calibration 2
checkout of tape drive, performing 29
cleaning cartridge
 description 49
 ordering 63
cleaning drive head 35
clearing error code log 42
compatible tape cartridges 2, 47
compressed capacity 1, 48
compressed data transfer rate 1
configuring drive to server, switch, or hub 29
connections
 Fibre Channel 27, 29
 Library/Drive Interface (LDI or RS-422) 28, 29
 power 27

connections (*continued*)
 SCSI 27, 28
connectivity 3
connectors
 Fibre Channel 1, 8, 15
 SCSI 1, 4, 14
converting an FMR tape to a scratch tape 41
copying a drive dump to tape 38
creating an FMR tape 37
current, electrical specifications 11
Customer Assistance Centers 104

D

danger notice, definition vii
data cartridge 48, 63
data transfer rate 1
degaussing a tape cartridge 52, 63
description of Ultrium 2 Tape Drive 1
device driver
 installing 28
 support 9
 use in recording errors 71
diagnostics
 fast read/write test 43
 Fibre Channel wrap test 40
 Library/Drive Interface wrap test (LDI or RS-422) 41
 running during installation 28
 SCSI wrap test 39
 selecting 36
 Test Cartridge & Media 43, 82
 Test Head 44
dimension of tape 2
dimension of tape drive 11
displaying error code log 42, 76
disposing of a tape cartridge 63
drive dump
 copying to tape 38
 forcing 38
 obtaining 75
drive head, cleaning 35

E

electronic emission regulations 102
enclosure
 mounting the tape drive into 26
 powering off 16
environmental specifications
 for media 62
 for tape drive 11
erasing tape 52
error code log
 clearing 42
 displaying 42
 viewing 76

errors

- descriptions and corrective actions 67
 - Fibre Channel 79
 - media 82
 - methods of receiving 66
 - obtaining from AS/400 or iSeries servers 71
 - obtaining from RS/6000 or pSeries servers 72
 - reported to enclosure 66
 - reported to server 71, 77
 - reported to tape drive error log 76
 - SCSI bus 77
 - TapeAlert flags 97
 - troubleshooting tips 65
 - using sense data 71
- exiting maintenance mode 45

F

- fabric, switched 6
- fast read/write test 43
- FC-AL topology 6
- FCC statement 102
- feature switches
 - Fibre Channel 15
 - SCSI 14
- Federal Communications Commission (FCC)
 - statement 102
- Fibre Channel drive
 - assigning an address 7
 - cables 8
 - connectivity 3
 - FC configuration/status connector 15
 - Fibre Channel connector 8, 15, 29
 - fixing errors 79
 - installing 8, 13
 - rear view 15
 - removing 8, 84
 - resetting 8
 - setting an ID 19
 - speed 7, 24
 - supported topologies 6
 - use of SCSI protocol 1, 6
 - World Wide Node Name 8
 - World Wide Port Name 8
 - wrap test 40
- Fibre Channel interface 1, 6
- Fibre Channel-Arbitrated Loop topology 6
- firmware
 - recovery from error 32
 - updating
 - from FMR tape 32, 37, 46
 - through Library Drive Interface 45
 - through SCSI or Fibre Channel interface 32, 45
- fixing an internal jam 88
- FMR tape
 - converting to scratch tape 41
 - creating 37
 - updating firmware from 37, 46
- forcing a drive dump 38

G

- getting help 104

H

- hard addressing 7
- head, testing 44
- height of tape drive 11
- help, getting 104
- host sense data 71
- HP
 - device driver support 9
 - supported server and operating system 9
- HP-UX 9

I

- ID, setting loop 19
- ID, setting SCSI 17
- inserting a tape cartridge 34
- insertion guide, location 47, 48
- installing the Ultrium 2 Tape Drive
 - Fibre Channel drive (Model T400F) 8, 13
 - SCSI drive (Model T400) 5, 13
- Intel-compatible servers
 - device driver support 9
 - supported server and operating system 3
- internal jam, fixing 88
- iSeries server
 - device driver support 9
 - obtaining error information from 71
 - supported server and operating system 3

J

- J33 connector 1, 4, 15

L

- label area, on Ultrium Tape Cartridge 47, 48
- label, for Ultrium Tape Cartridge 48
- laser safety notice viii, 6
- leader pin
 - location in tape cartridge 47, 48
 - reattaching to tape 57
 - repositioning in cartridge 55
- leader pin reattachment kit 58, 95
- LED 31, 32
- length of tape drive 11
- Library/Drive (LDI) wrap test, running 41
- Library/Drive Interface (LDI or RS-422)
 - connecting to the tape drive 28, 29
 - updating firmware from 45
- Library/Drive Interface (LDI or RS-422) connector
 - Fibre Channel drive 15
 - SCSI drive 14
- LID
 - description 7, 19
 - setting to add LIDs 19, 22
 - setting to get status of loop 19, 20

- LID/status connector 15
- light-emitting diode 31, 32
- Linear Tape-Open (LTO) Cartridge Memory (CM) 47, 48
- link services, changing 24
- Linux
 - device driver support 9
 - supported server and operating system 3
- load and unload cycle life for data cartridge 48
- loading a tape cartridge 34
- loop identifier (LID)
 - description 7, 19
 - setting to add LIDs 19, 22
 - setting to get status of loop 19, 20
- low-power mode 2
- LTO cartridge memory 47

M

- maintenance functions
 - clearing error code log 42
 - converting an FMR tape to a scratch tape 41
 - copying drive dump to tape 38
 - creating FMR tape 37
 - displaying error code log 42
 - forcing drive dump 38
 - inserting cartridge into tape drive 42
 - selecting 36
 - updating firmware from FMR tape 37
- maintenance mode
 - exiting 45
 - placing the tape drive in 36
 - selecting a maintenance or diagnostic function 36
- manual rewind tool, ordering 95
- manually removing a cartridge from the drive 85
- McDATA switch 6
- media-related errors 82
- media, using 47
- Microsoft Windows 2000
 - device driver support 9
 - supported server and operating system 3
- Microsoft Windows NT
 - device driver support 9
 - supported server and operating system 3
- models of Ultrium 2 Tape Drive 1
- mounting tape drive into an enclosure 26

N

- native storage capacity 1
- native sustained data transfer rate 1

O

- operating systems, supported 3
- operating the tape drive 31
- ordering tape cartridges and supplies 63

P

- panic reset, performing 33
- placing the tape drive in maintenance mode 36
- point-to-point connection 6
- port, Fibre Channel 6
- power
 - connecting to tape drive 27
- connectors
 - Fibre Channel 15
 - SCSI 14
- specifications 11
- powering off the enclosure 16
- problems, resolving 66
- pSeries server
 - obtaining error information from 72
 - supported server and operating system 3

R

- read/write capability 2
- rear view
 - Fibre Channel drive 15
 - SCSI drive 14
- recording method, of tape drive 2, 48
- red dot 33
- relative humidity specifications
 - for media 62
 - for tape drive 11
- removing the tape drive from an enclosure
 - Fibre Channel drive 8, 84
 - SCSI drive 5, 83
- resetting the tape drive
 - Fibre Channel drive 5
 - panic reset 33
 - SCSI drive 8
- RS-422 connector
 - Fibre Channel drive 15
 - SCSI drive 14
- RS-422 interface
 - connecting to the tape drive 28
 - updating firmware from 45
- RS-422 wrap test, running 41
- RS/6000
 - device driver support 9
 - obtaining error information from 72
 - supported server and operating system 3
- RS/6000 SP
 - device driver support 9
 - supported server and operating system 3

S

- safety notices, how to use vii
- SAN, supported components 1, 3
- SCSI drive
 - assigning an address 5
 - cables 4, 95
 - connecting to a bus 28
 - fixing errors 77
 - installing 5, 13

- SCSI drive *(continued)*
 - ordering a wrap tool 95
 - rear view 14
 - removing 5, 83
 - resetting 5
 - SCSI connector 14
 - SCSI ID connector 14
 - setting an ID 17
 - supported servers and operating systems 3
 - terminating 18
 - type of connector 1
 - type of interface 1, 4
 - updating firmware from 45
 - wrap test 39, 40
- SCSI interface 1, 4
- SCSI wrap test, running 39
- security of data on cartridge 63
- sense data, using 71
- server
 - configuring tape drive to 29
 - resolving errors 77
 - supported 3
 - updating firmware from 45
- servicing the tape drive 32, 83
- setting the Loop ID (AL_PA) 19
- setting the SCSI ID 17
- setting the write-protect switch 50
- single red dot 31, 33
- single-character display 31, 33
- sleep mode 2
- soft addressing 7
- Solaris 3
- specifications
 - media 62
 - power 11
 - tape drive 11
- speed matching 2
- speed of Fibre Channel interface, changing 24
- stacking tape cartridges 53
- static electricity, precautions for avoiding 13
- statistical analysis and reporting system (SARS) 82
- status light 31, 32
- storage area network (SAN) 1
- storage capacity 1
- Sun
 - device driver support 9
 - supported server and operating system 3
- supplies, ordering 95
- supplying TERMPower to the SCSI bus 18
- supported servers and operating systems 3
- supported TapeAlert flags 97
- sustained data transfer rate 3
- switched fabric loop 6

T

- tape cartridge
 - bar code labels
 - ordering 64
 - placement on cartridge 48
 - capacity 1, 2, 48

- tape cartridge *(continued)*
 - cartridge capacity, controlling 48
 - cartridge door 48
 - cartridge memory 47
 - cleaning cartridge 35, 47, 49
 - compatible cartridges 2, 47
 - data cartridge, description 47, 48
 - data security 63
 - degaussing 52, 63
 - description 48
 - dimension of tape 2, 48
 - disposal of 63
 - Fast Read/Write test 43
 - handling 50
 - inserting 34
 - label area 48
 - labels 48
 - leader pin
 - reattaching 57
 - repositioning 55
 - Linear Tape-Open Cartridge Memory (LTO-CM) 48
 - load and unload cycles 48
 - loading 34
 - manually removing 85
 - ordering 63
 - recording method, of tape drive 2, 48
 - relative humidity specifications 62
 - removing 35
 - resolving media-related problems 82
 - specifications for media 62
 - stacking 50
 - temperature specifications 62
 - Test Cartridge & Media diagnostic 43, 63, 82
 - unloading 35
 - using a repaired cartridge 55
 - wet bulb specifications 62
 - write-protect switch 48, 50
- TapeAlert flags, supported 97
- temperature specifications
 - for media 62
 - for tape drive 11
- terminating the SCSI bus 18
- TERMPower, supplying for SCSI bus 18
- Test Cartridge & Media diagnostic 43, 82
- Test Head diagnostic 44
- tolerance, power 11
- tools and supplies, ordering 95
- topologies, supported Fibre Channel 6
- topology, changing 24
- troubleshooting tips 65
- Tru64, device driver support 9
- two-node configuration 6

U

- Ultra160 LVD SCSI interface 1, 4
- universal cleaning cartridge 35, 47, 49
- unload button 31, 33
- unloading a tape cartridge 35
- unpacking the Ultrium 2 Tape Drive 16

- updating firmware
 - from FMR tape 32, 37, 46
 - through Library/Drive Interface (LDI or RS-422) 45
 - through SCSI or Fibre Channel interface 32, 45

V

- viewing latest supported attachments 9
- voltage 11

W

- warranty 104
- weight of tape drive 11
- wet bulb temperature specifications
 - for media 62
 - for tape drive 11
- width of tape drive 11
- Windows 2000
 - device driver support 9
 - supported server and operating system 3
- Windows NT
 - device driver support 9
 - supported server and operating system 3
- World Wide Node Name 8
- World Wide Port Name 8
- wrap plugs, ordering 95
- wrap test, running
 - Fibre Channel 40
 - LDI (or RS-422) 41
 - SCSI 39
- write-protect switch, location 47, 48, 50



Printed in U.S.A.

GA32-0455-00

