

# Veritas™ Volume Manager Administrator's Guide

Solaris

5.1



# Veritas™ Volume Manager Administrator's Guide

The software described in this book is furnished under a license agreement and may be used only in accordance with the terms of the agreement.

Product Version:5.1

Document version: 5.1.0

## Legal Notice

Copyright © 2009 Symantec Corporation. All rights reserved.

Symantec, the Symantec Logo, Veritas, and Veritas Storage Foundation are trademarks or registered trademarks of Symantec Corporation or its affiliates in the U.S. and other countries. Other names may be trademarks of their respective owners.

This Symantec product may contain third party software for which Symantec is required to provide attribution to the third party ("Third Party Programs"). Some of the Third Party Programs are available under open source or free software licenses. The License Agreement accompanying the Software does not alter any rights or obligations you may have under those open source or free software licenses. Please see the Third Party Legal Notice Appendix to this Documentation or TPIP ReadMe File accompanying this Symantec product for more information on the Third Party Programs.

The product described in this document is distributed under licenses restricting its use, copying, distribution, and decompilation/reverse engineering. No part of this document may be reproduced in any form by any means without prior written authorization of Symantec Corporation and its licensors, if any.

THE DOCUMENTATION IS PROVIDED "AS IS" AND ALL EXPRESS OR IMPLIED CONDITIONS, REPRESENTATIONS AND WARRANTIES, INCLUDING ANY IMPLIED WARRANTY OF MERCHANTABILITY, FITNESS FOR A PARTICULAR PURPOSE OR NON-INFRINGEMENT, ARE DISCLAIMED, EXCEPT TO THE EXTENT THAT SUCH DISCLAIMERS ARE HELD TO BE LEGALLY INVALID. SYMANTEC CORPORATION SHALL NOT BE LIABLE FOR INCIDENTAL OR CONSEQUENTIAL DAMAGES IN CONNECTION WITH THE FURNISHING, PERFORMANCE, OR USE OF THIS DOCUMENTATION. THE INFORMATION CONTAINED IN THIS DOCUMENTATION IS SUBJECT TO CHANGE WITHOUT NOTICE.

The Licensed Software and Documentation are deemed to be commercial computer software as defined in FAR 12.212 and subject to restricted rights as defined in FAR Section 52.227-19 "Commercial Computer Software - Restricted Rights" and DFARS 227.7202, "Rights in Commercial Computer Software or Commercial Computer Software Documentation", as applicable, and any successor regulations. Any use, modification, reproduction release, performance, display or disclosure of the Licensed Software and Documentation by the U.S. Government shall be solely in accordance with the terms of this Agreement.

Symantec Corporation  
20330 Stevens Creek Blvd.  
Cupertino, CA 95014

<http://www.symantec.com>

# Technical Support

Symantec Technical Support maintains support centers globally. Technical Support's primary role is to respond to specific queries about product features and functionality. The Technical Support group also creates content for our online Knowledge Base. The Technical Support group works collaboratively with the other functional areas within Symantec to answer your questions in a timely fashion. For example, the Technical Support group works with Product Engineering and Symantec Security Response to provide alerting services and virus definition updates.

Symantec's maintenance offerings include the following:

- A range of support options that give you the flexibility to select the right amount of service for any size organization
- Telephone and Web-based support that provides rapid response and up-to-the-minute information
- Upgrade assurance that delivers automatic software upgrade protection
- Global support that is available 24 hours a day, 7 days a week
- Advanced features, including Account Management Services

For information about Symantec's Maintenance Programs, you can visit our Web site at the following URL:

[www.symantec.com/techsupp/](http://www.symantec.com/techsupp/)

## Contacting Technical Support

Customers with a current maintenance agreement may access Technical Support information at the following URL:

[www.symantec.com/business/support/index.jsp](http://www.symantec.com/business/support/index.jsp)

Before contacting Technical Support, make sure you have satisfied the system requirements that are listed in your product documentation. Also, you should be at the computer on which the problem occurred, in case it is necessary to replicate the problem.

When you contact Technical Support, please have the following information available:

- Product release level
- Hardware information
- Available memory, disk space, and NIC information
- Operating system

- Version and patch level
- Network topology
- Router, gateway, and IP address information
- Problem description:
  - Error messages and log files
  - Troubleshooting that was performed before contacting Symantec
  - Recent software configuration changes and network changes

## Licensing and registration

If your Symantec product requires registration or a license key, access our technical support Web page at the following URL:

[www.symantec.com/techsupp/](http://www.symantec.com/techsupp/)

## Customer service

Customer service information is available at the following URL:

[www.symantec.com/techsupp/](http://www.symantec.com/techsupp/)

Customer Service is available to assist with the following types of issues:

- Questions regarding product licensing or serialization
- Product registration updates, such as address or name changes
- General product information (features, language availability, local dealers)
- Latest information about product updates and upgrades
- Information about upgrade assurance and maintenance contracts
- Information about the Symantec Buying Programs
- Advice about Symantec's technical support options
- Nontechnical presales questions
- Issues that are related to CD-ROMs or manuals

## Maintenance agreement resources

If you want to contact Symantec regarding an existing maintenance agreement, please contact the maintenance agreement administration team for your region as follows:

Asia-Pacific and Japan	<a href="mailto:contractsadmin@symantec.com">contractsadmin@symantec.com</a>
Europe, Middle-East, and Africa	<a href="mailto:semea@symantec.com">semea@symantec.com</a>
North America and Latin America	<a href="mailto:supportsolutions@symantec.com">supportolutions@symantec.com</a>

## Additional enterprise services

Symantec offers a comprehensive set of services that allow you to maximize your investment in Symantec products and to develop your knowledge, expertise, and global insight, which enable you to manage your business risks proactively.

Enterprise services that are available include the following:

Symantec Early Warning Solutions	These solutions provide early warning of cyber attacks, comprehensive threat analysis, and countermeasures to prevent attacks before they occur.
Managed Security Services	These services remove the burden of managing and monitoring security devices and events, ensuring rapid response to real threats.
Consulting Services	Symantec Consulting Services provide on-site technical expertise from Symantec and its trusted partners. Symantec Consulting Services offer a variety of prepackaged and customizable options that include assessment, design, implementation, monitoring, and management capabilities. Each is focused on establishing and maintaining the integrity and availability of your IT resources.
Educational Services	Educational Services provide a full array of technical training, security education, security certification, and awareness communication programs.

To access more information about Enterprise services, please visit our Web site at the following URL:

[www.symantec.com](http://www.symantec.com)

Select your country or language from the site index.

# Contents

Technical Support .....	4
Chapter 1      Understanding Veritas Volume Manager .....	21
About Veritas Volume Manager .....	21
VxVM and the operating system .....	22
How data is stored .....	23
How VxVM handles storage management .....	23
Physical objects .....	24
Virtual objects .....	29
Volume layouts in VxVM .....	36
Non-layered volumes .....	36
Layered volumes .....	37
Layout methods .....	37
Concatenation, spanning, and carving .....	38
Striping (RAID-0) .....	40
Mirroring (RAID-1) .....	43
Striping plus mirroring (mirrored-stripe or RAID-0+1) .....	44
Mirroring plus striping (striped-mirror, RAID-1+0 or RAID-10) .....	45
RAID-5 (striping with parity) .....	46
Online relayout .....	53
How online relayout works .....	53
Limitations of online relayout .....	56
Transformation characteristics .....	57
Transformations and volume length .....	57
Volume resynchronization .....	58
Dirty flags .....	58
Resynchronization process .....	58
Dirty region logging .....	59
Log subdisks and plexes .....	59
Sequential DRL .....	60
SmartSync recovery accelerator .....	60
Volume snapshots .....	62
Comparison of snapshot features .....	63
FastResync .....	64
FastResync enhancements .....	65

	Non-persistent FastResync .....	66
	Persistent FastResync .....	66
	DCO volume versioning .....	67
	FastResync limitations .....	72
	Hot-relocation .....	73
	Volume sets .....	73
	Configuration of volumes on SAN storage .....	73
Chapter 2	Provisioning new usable storage .....	77
	Provisioning new usable storage .....	77
	Growing existing storage by adding a new LUN .....	78
	Growing existing storage by growing the LUN .....	78
Chapter 3	Administering disks .....	81
	About disk management .....	82
	Disk devices .....	82
	Disk device naming in VxVM .....	83
	Private and public disk regions .....	85
	Discovering and configuring newly added disk devices .....	87
	Partial device discovery .....	88
	Discovering disks and dynamically adding disk arrays .....	89
	Third-party driver coexistence .....	91
	How to administer the Device Discovery Layer .....	92
	Disks under VxVM control .....	105
	VxVM coexistence with SVM and ZFS .....	106
	Changing the disk-naming scheme .....	107
	Displaying the disk-naming scheme .....	109
	Regenerating persistent device names .....	110
	Changing device naming for TPD-controlled enclosures .....	110
	Simple or nopriv disks with enclosure-based naming .....	112
	Discovering the association between enclosure-based disk names and OS-based disk names .....	114
	Disk installation and formatting .....	114
	Displaying or changing default disk layout attributes .....	115
	Adding a disk to VxVM .....	115
	Disk reinitialization .....	123
	Using vxdiskadd to put a disk under VxVM control .....	124
	RAM disk support in VxVM .....	124
	Encapsulating a disk .....	126
	Failure of disk encapsulation .....	129
	Using nopriv disks for encapsulation .....	130
	Rootability .....	131



Booting root volumes .....	132
Boot-time volume restrictions .....	133
Mirroring an encapsulated root disk .....	134
Booting from alternate boot disks .....	135
Mirroring other file systems on the root disk .....	137
Encapsulating SAN disks .....	138
Administering an encapsulated boot disk .....	139
Unencapsulating the root disk .....	141
Displaying disk information .....	142
Displaying disk information with vxdiskadm .....	143
Dynamic LUN expansion .....	144
Removing disks .....	145
Removing a disk with subdisks .....	146
Removing a disk with no subdisks .....	147
Removing a disk from VxVM control .....	147
Removing and replacing disks .....	148
Replacing a failed or removed disk .....	152
Removing and replacing a disk in a Sun StorEdge A5x00 disk array .....	154
Enabling a disk .....	155
Taking a disk offline .....	156
Renaming a disk .....	156
Reserving disks .....	157
Changing host LUN configurations online .....	158
Removing LUNs dynamically from an existing target ID .....	159
Adding new LUNs dynamically to a new target ID .....	160
About detecting target ID reuse if the operating system device tree is not cleaned up .....	161
Scanning an operating system device tree after adding or removing LUNs .....	162
Cleaning up the operating system device tree after removing LUNs .....	162
Chapter 4   Administering Dynamic Multipathing .....	165
How DMP works .....	165
How DMP monitors I/O on paths .....	169
Load balancing .....	170
Dynamic Reconfiguration .....	171
Booting from DMP devices .....	171
DMP in a clustered environment .....	171
Disabling multipathing and making devices invisible to VxVM .....	172
Enabling multipathing and making devices visible to VxVM .....	173

Enabling and disabling I/O for controllers and storage processors .....	174
Displaying DMP database information .....	175
Displaying the paths to a disk .....	175
Setting customized names for DMP nodes .....	178
DMP coexistence with native multipathing .....	178
Administering DMP using vxddmpadm .....	179
Retrieving information about a DMP node .....	180
Displaying consolidated information about the DMP nodes .....	181
Displaying the members of a LUN group .....	182
Displaying paths controlled by a DMP node, controller, enclosure, or array port .....	183
Displaying information about controllers .....	185
Displaying information about enclosures .....	186
Displaying information about array ports .....	187
Displaying information about TPD-controlled devices .....	187
Displaying extended device attributes .....	188
Suppressing or including devices for VxVM or DMP control .....	190
Gathering and displaying I/O statistics .....	191
Setting the attributes of the paths to an enclosure .....	197
Displaying the redundancy level of a device or enclosure .....	198
Specifying the minimum number of active paths .....	199
Displaying the I/O policy .....	200
Specifying the I/O policy .....	200
Disabling I/O for paths, controllers or array ports .....	206
Enabling I/O for paths, controllers or array ports .....	208
Upgrading disk controller firmware .....	208
Renaming an enclosure .....	209
Configuring the response to I/O failures .....	210
Configuring the I/O throttling mechanism .....	211
Displaying recovery option values .....	213
Configuring DMP path restoration policies .....	214
Stopping the DMP path restoration thread .....	216
Displaying the status of the DMP path restoration thread .....	216
Displaying information about the DMP error-handling thread .....	216
Configuring array policy modules .....	216
 Chapter 5	
Creating and administering disk groups .....	219
About disk groups .....	220
Specification of disk groups to commands .....	222
System-wide reserved disk groups .....	222

Rules for determining the default disk group .....	222
Displaying disk group information .....	224
Displaying free space in a disk group .....	225
Creating a disk group .....	226
Adding a disk to a disk group .....	227
Removing a disk from a disk group .....	227
Moving disks between disk groups .....	228
Deporting a disk group .....	229
Importing a disk group .....	230
Handling of minor number conflicts .....	231
Moving disk groups between systems .....	233
Handling errors when importing disks .....	234
Reserving minor numbers for disk groups .....	236
Compatibility of disk groups between platforms .....	238
Handling cloned disks with duplicated identifiers .....	239
Writing a new UDID to a disk .....	240
Importing a disk group containing cloned disks .....	240
Sample cases of operations on cloned disks .....	242
Considerations when using EMC CLARiiON SNAPSHOT LUNs .....	248
Renaming a disk group .....	248
Handling conflicting configuration copies .....	250
Example of a serial split brain condition in a cluster .....	250
Correcting conflicting configuration information .....	254
Reorganizing the contents of disk groups .....	256
Limitations of disk group split and join .....	260
Listing objects potentially affected by a move .....	261
Moving objects between disk groups .....	263
Splitting disk groups .....	266
Joining disk groups .....	267
Disabling a disk group .....	269
Destroying a disk group .....	269
Recovering a destroyed disk group .....	270
Upgrading a disk group .....	270
Managing the configuration daemon in VxVM .....	275
Backing up and restoring disk group configuration data .....	276
Using vxnotify to monitor configuration changes .....	276
Working with ISP disk groups .....	277

Chapter 6	Creating and administering subdisks and plexes .....	279
	About subdisks .....	280
	Creating subdisks .....	280
	Displaying subdisk information .....	281
	Moving subdisks .....	282
	Splitting subdisks .....	282
	Joining subdisks .....	283
	Associating subdisks with plexes .....	283
	Associating log subdisks .....	285
	Dissociating subdisks from plexes .....	286
	Removing subdisks .....	287
	Changing subdisk attributes .....	287
	About plexes .....	288
	Creating plexes .....	289
	Creating a striped plex .....	289
	Displaying plex information .....	289
	Plex states .....	290
	Plex condition flags .....	293
	Plex kernel states .....	294
	Attaching and associating plexes .....	294
	Taking plexes offline .....	295
	Detaching plexes .....	296
	Reattaching plexes .....	296
	Automatic plex reattachment .....	297
	Moving plexes .....	298
	Copying volumes to plexes .....	299
	Dissociating and removing plexes .....	299
	Changing plex attributes .....	300
Chapter 7	Creating volumes .....	303
	About volume creation .....	304
	Types of volume layouts .....	304
	Supported volume logs and maps .....	306
	Creating a volume .....	307
	Advanced approach .....	307
	Assisted approach .....	307
	Using vxassist .....	308
	Setting default values for vxassist .....	309
	Using the SmartMove™ feature while attaching a plex .....	311
	Discovering the maximum size of a volume .....	311
	Disk group alignment constraints on volumes .....	312

Creating a volume on any disk .....	312
Creating a volume on specific disks .....	313
Creating a volume on SSD devices .....	314
Specifying ordered allocation of storage to volumes .....	316
Creating a mirrored volume .....	319
Creating a mirrored-concatenated volume .....	320
Creating a concatenated-mirror volume .....	320
Creating a volume with a version 0 DCO volume .....	321
Creating a volume with a version 20 DCO volume .....	324
Creating a volume with dirty region logging enabled .....	324
Creating a striped volume .....	325
Creating a mirrored-stripe volume .....	326
Creating a striped-mirror volume .....	327
Mirroring across targets, controllers or enclosures .....	327
Mirroring across media types (SSD and HDD) .....	328
Creating a RAID-5 volume .....	329
Creating tagged volumes .....	330
Creating a volume using vxmake .....	331
Creating a volume using a vxmake description file .....	333
Initializing and starting a volume .....	334
Initializing and starting a volume created using vxmake .....	335
Accessing a volume .....	335
Chapter 8      Administering volumes .....	337
About volume administration .....	338
Displaying volume information .....	338
Volume states .....	340
Volume kernel states .....	341
Monitoring and controlling tasks .....	342
Specifying task tags .....	342
Managing tasks with vxtask .....	343
Using Thin Provisioning .....	345
About Thin Provisioning .....	345
About Thin Reclamation .....	346
Thin Reclamation of a disk, a disk group, or an enclosure .....	346
Triggering space reclamation .....	347
Admin operations on an unmounted VxFS thin volume .....	348
Using SmartMove with Thin Provisioning .....	349
Stopping a volume .....	349
Putting a volume in maintenance mode .....	350
Starting a volume .....	350
Resizing a volume .....	351

Resizing volumes with vxresize .....	352
Resizing volumes with vxassist .....	353
Resizing volumes with vxvol .....	355
Adding a mirror to a volume .....	355
Mirroring all volumes .....	356
Mirroring volumes on a VM disk .....	356
Additional mirroring considerations .....	357
Removing a mirror .....	359
Adding logs and maps to volumes .....	360
Preparing a volume for DRL and instant snapshots .....	360
Specifying storage for version 20 DCO plexes .....	362
Using a DCO and DCO volume with a RAID-5 volume .....	363
Determining the DCO version number .....	363
Determining if DRL is enabled on a volume .....	364
Determining if DRL logging is active on a volume .....	365
Disabling and re-enabling DRL .....	365
Removing support for DRL and instant snapshots from a volume .....	365
Adding traditional DRL logging to a mirrored volume .....	366
Removing a traditional DRL log .....	367
Upgrading existing volumes to use version 20 DCOs .....	367
Setting tags on volumes .....	369
Changing the read policy for mirrored volumes .....	371
Removing a volume .....	372
Moving volumes from a VM disk .....	373
Enabling FastResync on a volume .....	374
Checking whether FastResync is enabled on a volume .....	375
Disabling FastResync .....	375
Performing online relayout .....	376
Permitted relayout transformations .....	376
Specifying a non-default layout .....	379
Specifying a plex for relayout .....	380
Tagging a relayout operation .....	380
Viewing the status of a relayout .....	381
Controlling the progress of a relayout .....	381
Monitoring Thin Reclamation using the vxtask command .....	382
Converting between layered and non-layered volumes .....	383
Adding a RAID-5 log .....	384
Adding a RAID-5 log using vxplex .....	384
Removing a RAID-5 log .....	385

Chapter 9	Administering volume snapshots .....	387
	About volume snapshots .....	387
	Traditional third-mirror break-off snapshots .....	389
	Full-sized instant snapshots .....	390
	Space-optimized instant snapshots .....	392
	Emulation of third-mirror break-off snapshots .....	393
	Linked break-off snapshot volumes .....	393
	Cascaded snapshots .....	395
	Creating a snapshot of a snapshot .....	396
	Creating multiple snapshots .....	398
	Restoring the original volume from a snapshot .....	399
	Creating instant snapshots .....	400
	Preparing to create instant and break-off snapshots .....	402
	Creating and managing space-optimized instant snapshots .....	406
	Creating and managing full-sized instant snapshots .....	408
	Creating and managing third-mirror break-off snapshots .....	410
	Creating and managing linked break-off snapshot volumes .....	413
	Creating multiple instant snapshots .....	415
	Creating instant snapshots of volume sets .....	416
	Adding snapshot mirrors to a volume .....	418
	Removing a snapshot mirror .....	419
	Removing a linked break-off snapshot volume .....	419
	Adding a snapshot to a cascaded snapshot hierarchy .....	419
	Refreshing an instant snapshot .....	420
	Reattaching an instant snapshot .....	420
	Reattaching a linked break-off snapshot volume .....	421
	Restoring a volume from an instant snapshot .....	422
	Dissociating an instant snapshot .....	423
	Removing an instant snapshot .....	423
	Splitting an instant snapshot hierarchy .....	424
	Displaying instant snapshot information .....	424
	Controlling instant snapshot synchronization .....	426
	Listing the snapshots created on a cache .....	428
	Tuning the autogrow attributes of a cache .....	428
	Growing and shrinking a cache .....	430
	Removing a cache .....	430
	Creating traditional third-mirror break-off snapshots .....	431
	Converting a plex into a snapshot plex .....	435
	Creating multiple snapshots with the vxassist command .....	436
	Reattaching a snapshot volume .....	437
	Adding plexes to a snapshot volume .....	438
	Dissociating a snapshot volume .....	439

	Displaying snapshot information .....	439
	Adding a version 0 DCO and DCO volume .....	440
	Specifying storage for version 0 DCO plexes .....	442
	Removing a version 0 DCO and DCO volume .....	444
	Reattaching a version 0 DCO and DCO volume .....	444
Chapter 10	Creating and administering volume sets .....	447
	About volume sets .....	447
	Creating a volume set .....	448
	Adding a volume to a volume set .....	448
	Removing a volume from a volume set .....	449
	Listing details of volume sets .....	449
	Stopping and starting volume sets .....	450
	Raw device node access to component volumes .....	451
	Enabling raw device access when creating a volume set .....	452
	Displaying the raw device access settings for a volume set .....	453
	Controlling raw device access for an existing volume set .....	453
Chapter 11	Configuring off-host processing .....	455
	About off-host processing solutions .....	455
	Implementation of off-host processing solutions .....	456
	Implementing off-host online backup .....	457
	Implementing decision support .....	461
Chapter 12	Administering hot-relocation .....	467
	About hot-relocation .....	467
	How hot-relocation works .....	468
	Partial disk failure mail messages .....	471
	Complete disk failure mail messages .....	472
	How space is chosen for relocation .....	473
	How reclamation on a deleted volume works .....	474
	Configuring a system for hot-relocation .....	475
	Displaying spare disk information .....	476
	Marking a disk as a hot-relocation spare .....	476
	Removing a disk from use as a hot-relocation spare .....	478
	Excluding a disk from hot-relocation use .....	478
	Making a disk available for hot-relocation use .....	479
	Configuring hot-relocation to use only spare disks .....	480
	Moving relocated subdisks .....	480
	Moving relocated subdisks using vxdiskadm .....	481
	Moving relocated subdisks using vxassist .....	482



	Moving relocated subdisks using vxunreloc .....	483
	Restarting vxunreloc after errors .....	485
	Modifying the behavior of hot-relocation .....	486
<b>Chapter 13</b>	<b>Administering cluster functionality .....</b>	<b>489</b>
	Overview of clustering .....	489
	Overview of cluster volume management .....	490
	Private and shared disk groups .....	492
	Activation modes of shared disk groups .....	493
	Connectivity policy of shared disk groups .....	495
	Effect of disk connectivity on cluster reconfiguration .....	500
	Limitations of shared disk groups .....	500
	Multiple host failover configurations .....	501
	Import lock .....	501
	Failover .....	502
	Corruption of disk group configuration .....	502
	About the cluster functionality of VxVM .....	503
	Cluster initialization and configuration .....	505
	Cluster reconfiguration .....	505
	Volume reconfiguration .....	508
	Node shutdown .....	512
	Cluster shutdown .....	513
	Dirty region logging in cluster environments .....	513
	How DRL works in a cluster environment .....	514
	Administering VxVM in cluster environments .....	514
	Requesting node status and discovering the master node .....	515
	Determining if a LUN is in a shareable disk group .....	516
	Listing shared disk groups .....	516
	Creating a shared disk group .....	517
	Importing disk groups as shared .....	518
	Converting a disk group from shared to private .....	519
	Moving objects between shared disk groups .....	519
	Splitting shared disk groups .....	519
	Joining shared disk groups .....	520
	Changing the activation mode on a shared disk group .....	520
	Setting the disk detach policy on a shared disk group .....	520
	Setting the disk group failure policy on a shared disk group .....	521
	Creating volumes with exclusive open access by a node .....	521
	Setting exclusive open access to a volume by a node .....	521
	Displaying the cluster protocol version .....	522
	Displaying the supported cluster protocol version range .....	522
	Upgrading the cluster protocol version .....	523

	Recovering volumes in shared disk groups .....	523
	Obtaining cluster performance statistics .....	523
Chapter 14	Administering sites and remote mirrors .....	525
	About sites and remote mirrors .....	525
	About site-based allocation .....	528
	About site consistency .....	529
	About site tags .....	530
	About the site read policy .....	530
	Making an existing disk group site consistent .....	531
	Configuring a new disk group as a Remote Mirror configuration .....	532
	Fire drill – testing the configuration .....	533
	Simulating site failure .....	534
	Verifying the secondary site .....	534
	Recovery from simulated site failure .....	534
	Changing the site name .....	535
	Resetting the site name for a host .....	535
	Administering the Remote Mirror configuration .....	535
	Configuring site tagging for disks or enclosures .....	535
	Configuring automatic site tagging for a disk group .....	536
	Configuring site consistency on a volume .....	537
	Examples of storage allocation by specifying sites .....	537
	Displaying site information .....	539
	Failure and recovery scenarios .....	540
	Recovering from a loss of site connectivity .....	541
	Recovering from host failure .....	541
	Recovering from storage failure .....	541
	Recovering from site failure .....	542
	Automatic site reattachment .....	542
Chapter 15	Performance monitoring and tuning .....	545
	Performance guidelines .....	545
	Data assignment .....	545
	Striping .....	546
	Mirroring .....	546
	Combining mirroring and striping .....	547
	RAID-5 .....	547
	Volume read policies .....	547
	Performance monitoring .....	548
	Setting performance priorities .....	548
	Obtaining performance data .....	549
	Using performance data .....	550

	Tuning VxVM .....	554
	General tuning guidelines .....	554
	Tuning guidelines for large systems .....	554
	Changing the values of tunables .....	555
	Tunable parameters for VxVM .....	556
	DMP tunable parameters .....	566
	Disabling I/O statistics collection .....	573
Appendix A	Using Veritas Volume Manager commands .....	575
	About Veritas Volume Manager commands .....	575
	Online manual pages .....	597
	Section 1M – administrative commands .....	598
	Section 4 – file formats .....	601
	Section 7 – device driver interfaces .....	602
Appendix B	Configuring Veritas Volume Manager .....	603
	Setup tasks after installation .....	603
	Unsupported disk arrays .....	604
	Foreign devices .....	604
	Initialization of disks and creation of disk groups .....	604
	Guidelines for configuring storage .....	604
	Mirroring guidelines .....	605
	Dirty region logging guidelines .....	606
	Striping guidelines .....	607
	RAID-5 guidelines .....	608
	Hot-relocation guidelines .....	608
	Accessing volume devices .....	609
	VxVM’s view of multipathed devices .....	610
	Cluster support .....	610
	Configuring shared disk groups .....	610
	Converting existing VxVM disk groups to shared disk groups .....	612
Glossary	.....	613
Index	.....	621



# Understanding Veritas Volume Manager

This chapter includes the following topics:

- [About Veritas Volume Manager](#)
- [VxVM and the operating system](#)
- [How VxVM handles storage management](#)
- [Volume layouts in VxVM](#)
- [Online relayout](#)
- [Volume resynchronization](#)
- [Dirty region logging](#)
- [Volume snapshots](#)
- [FastResync](#)
- [Hot-relocation](#)
- [Volume sets](#)
- [Configuration of volumes on SAN storage](#)

## About Veritas Volume Manager

Veritas™ Volume Manager (VxVM) by Symantec is a storage management subsystem that allows you to manage physical disks and logical unit numbers (LUNs) as logical devices called volumes. A VxVM volume appears to applications

and the operating system as a physical device on which file systems, databases and other managed data objects can be configured.

VxVM provides easy-to-use online disk storage management for computing environments and Storage Area Network (SAN) environments. By supporting the Redundant Array of Independent Disks (RAID) model, VxVM can be configured to protect against disk and hardware failure, and to increase I/O throughput. Additionally, VxVM provides features that enhance fault tolerance and fast recovery from disk failure or storage array failure.

VxVM overcomes restrictions imposed by hardware disk devices and by LUNs by providing a logical volume management layer. This allows volumes to span multiple disks and LUNs.

VxVM provides the tools to improve performance and ensure data availability and integrity. You can also use VxVM to dynamically configure storage while the system is active.

For more information on administering Veritas Volume Manager, see the following documentation:

- *Veritas Storage Foundation Advanced Features Administrator's Guide*

This guide provides more information on using the Cross-platform Data Sharing (CDS) feature of Veritas Volume Manager. CDS lets you move VxVM disks and objects between machines that run different operating systems. To use CDS, you need a Veritas Storage Foundation license.

This guide also gives you guidelines about how to use FlashSnap software to implement point-in-time copy solutions for backup and database replication. To use FlashSnap, you need a separate license.

This guide also describes the Veritas Thin Provisioning and SmartMove™ features which let you take advantage of thin storage.

- *Veritas Volume Manager Troubleshooting Guide*

This guide describes how to recover from hardware failure, configure and recover disk groups, and log commands and transactions. It also documents common error messages and suggests solutions.

## VxVM and the operating system

VxVM operates as a subsystem between your operating system and your data management systems, such as file systems and database management systems. VxVM is tightly coupled with the operating system. Before a disk or LUN can be brought under VxVM control, the disk must be accessible through the operating system device interface. VxVM is layered on top of the operating system interface services, and is dependent upon how the operating system accesses physical disks.

VxVM is dependent upon the operating system for the following functionality:

- operating system (disk) devices
- device handles
- VxVM dynamic multipathing (DMP) metadvice

VxVM relies on the following constantly-running daemons and kernel threads for its operation:

`vxconfigd`

The VxVM configuration daemon maintains disk and group configurations and communicates configuration changes to the kernel, and modifies configuration information stored on disks.

`vxiod`

VxVM I/O kernel threads provide extended I/O operations without blocking calling processes. By default, 16 I/O threads are started at boot time, and at least one I/O thread must continue to run at all times.

`vxrelocd`

The hot-relocation daemon monitors VxVM for events that affect redundancy, and performs hot-relocation to restore redundancy. If thin provision disks are configured in the system, then the storage space of a deleted volume is reclaimed by this daemon as configured by the policy.

## How data is stored

There are several methods used to store data on physical disks. These methods organize data on the disk so the data can be stored and retrieved efficiently. The basic method of disk organization is called formatting. Formatting prepares the hard disk so that files can be written to and retrieved from the disk by using a prearranged storage pattern.

Hard disks are formatted, and information stored, using two methods: physical-storage layout and logical-storage layout. VxVM uses the logical-storage layout method.

See [“How VxVM handles storage management”](#) on page 23.

## How VxVM handles storage management

VxVM uses the following types of objects to handle storage management:

Physical objects	Physical disks, LUNs (virtual disks implemented in hardware), or other hardware with block and raw operating system device interfaces that are used to store data.  See “ <a href="#">Physical objects</a> ” on page 24.
Virtual objects	When one or more physical disks are brought under the control of VxVM, it creates virtual objects called volumes on those physical disks. Each volume records and retrieves data from one or more physical disks. Volumes are accessed by file systems, databases, or other applications in the same way that physical disks are accessed. Volumes are also composed of other virtual objects (plexes and subdisks) that are used in changing the volume configuration. Volumes and their virtual components are called virtual objects or VxVM objects.  See “ <a href="#">Virtual objects</a> ” on page 29.

## Physical objects

A physical disk is the basic storage device (media) where the data is ultimately stored. You can access the data on a physical disk by using a device name to locate the disk. The physical disk device name varies with the computer system you use. Not all parameters are used on all systems.

Typical device names are of the form `c#t#d#s#`, where `c#` specifies the controller, `t#` specifies the target ID, `d#` specifies the disk, and `s#` specifies the partition or slice. For example, device name `c0t0d0s2` is the entire hard disk connected to controller number 0 in the system, with a target ID of 0, and physical disk number 0.

[Figure 1-1](#) shows how a physical disk and device name (*devname*) are illustrated in this document.

**Figure 1-1** Physical disk example



VxVM writes identification information on physical disks under VxVM control (VM disks). VxVM disks can be identified even after physical disk disconnection or system outages. VxVM can then re-form disk groups and logical objects to provide failure detection and to speed system recovery.



## Partitions

Figure 1-2 shows how a physical disk can be divided into one or more slices, also known as partitions.

Figure 1-2 Slice example

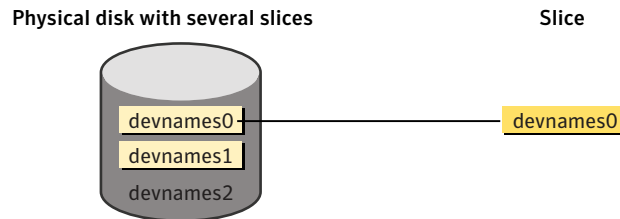

The slice number is added at the end of the *devname*, and is denoted by *s#*. Note that slice *s2* refers to an entire physical disk for non-EFI disks.

## Disk arrays

Performing I/O to disks is a relatively slow process because disks are physical devices that require time to move the heads to the correct position on the disk before reading or writing. If all of the read or write operations are done to individual disks, one at a time, the read-write time can become unmanageable. Performing these operations on multiple disks can help to reduce this problem.

A disk array is a collection of physical disks that VxVM can represent to the operating system as one or more virtual disks or volumes. The volumes created by VxVM look and act to the operating system like physical disks. Applications that interact with volumes should work in the same way as with physical disks.

Figure 1-3 shows how VxVM represents the disks in a disk array as several volumes to the operating system.

**Figure 1-3** How VxVM presents the disks in a disk array as volumes to the operating system

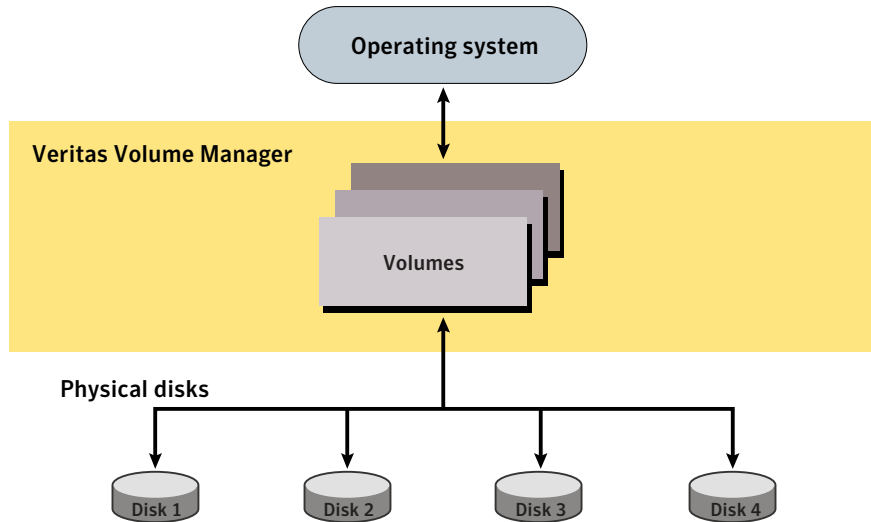

Data can be spread across several disks within an array to distribute or balance I/O operations across the disks. Using parallel I/O across multiple disks in this way improves I/O performance by increasing data transfer speed and overall throughput for the array.

## Multiple paths to disk arrays

Some disk arrays provide multiple ports to access their disk devices. These ports, coupled with the host bus adaptor (HBA) controller and any data bus or I/O processor local to the array, make up multiple hardware paths to access the disk devices. Such disk arrays are called multipathed disk arrays. This type of disk array can be connected to host systems in many different configurations, (such as multiple ports connected to different controllers on a single host, chaining of the ports through a single controller on a host, or ports connected to different hosts simultaneously).

See [“How DMP works”](#) on page 165.

## Device discovery

Device discovery is the term used to describe the process of discovering the disks that are attached to a host. This feature is important for DMP because it needs to support a growing number of disk arrays from a number of vendors. In conjunction with the ability to discover the devices attached to a host, the Device Discovery

service enables you to add support dynamically for new disk arrays. This operation, which uses a facility called the Device Discovery Layer (DDL), is achieved without the need for a reboot.

This means that you can dynamically add a new disk array to a host, and run a command which scans the operating system's device tree for all the attached disk devices, and reconfigures DMP with the new device database.

See [“How to administer the Device Discovery Layer”](#) on page 92.

## Enclosure-based naming

Enclosure-based naming provides an alternative to operating system-based device naming. This allows disk devices to be named for enclosures rather than for the controllers through which they are accessed. In a Storage Area Network (SAN) that uses Fibre Channel hubs or fabric switches, information about disk location provided by the operating system may not correctly indicate the physical location of the disks. For example, `c#t#d#s#` naming assigns controller-based device names to disks in separate enclosures that are connected to the same host controller. Enclosure-based naming allows VxVM to access enclosures as separate physical entities. By configuring redundant copies of your data on separate enclosures, you can safeguard against failure of one or more enclosures.

[Figure 1-4](#) shows a typical SAN environment where host controllers are connected to multiple enclosures in a daisy chain or through a Fibre Channel hub or fabric switch.

**Figure 1-4** Example configuration for disk enclosures connected via a fibre channel hub or switch

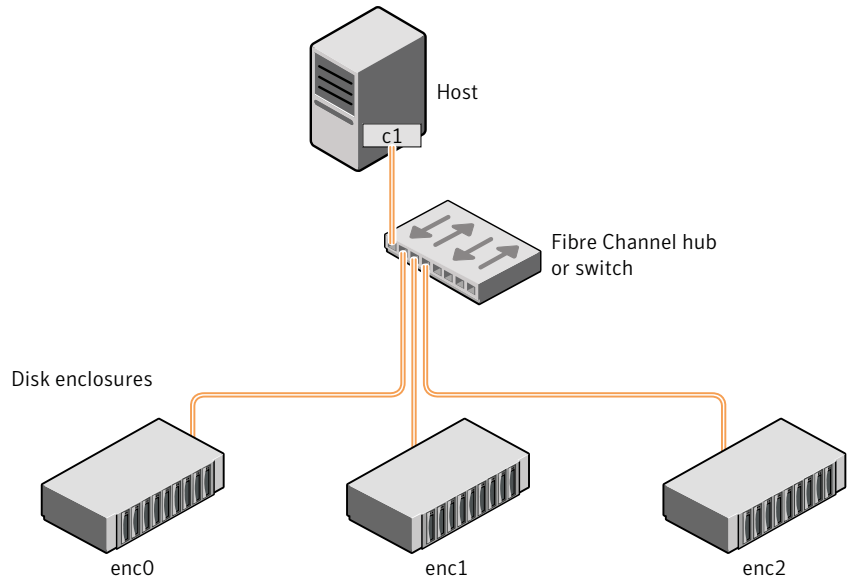

In such a configuration, enclosure-based naming can be used to refer to each disk within an enclosure. For example, the device names for the disks in enclosure `enc0` are named `enc0_0`, `enc0_1`, and so on. The main benefit of this scheme is that it allows you to quickly determine where a disk is physically located in a large SAN configuration.

In most disk arrays, you can use hardware-based storage management to represent several physical disks as one LUN to the operating system. In such cases, VxVM also sees a single logical disk device rather than its component disks. For this reason, when reference is made to a disk within an enclosure, this disk may be either a physical disk or a LUN.

Another important benefit of enclosure-based naming is that it enables VxVM to avoid placing redundant copies of data in the same enclosure. This is a good thing to avoid as each enclosure can be considered to be a separate fault domain. For example, if a mirrored volume were configured only on the disks in enclosure `enc1`, the failure of the cable between the hub and the enclosure would make the entire volume unavailable.

If required, you can replace the default name that VxVM assigns to an enclosure with one that is more meaningful to your configuration.

See [“Renaming an enclosure”](#) on page 209.

Figure 1-5 shows a High Availability (HA) configuration where redundant-loop access to storage is implemented by connecting independent controllers on the host to separate hubs with independent paths to the enclosures.

**Figure 1-5** Example HA configuration using multiple hubs or switches to provide redundant loop access

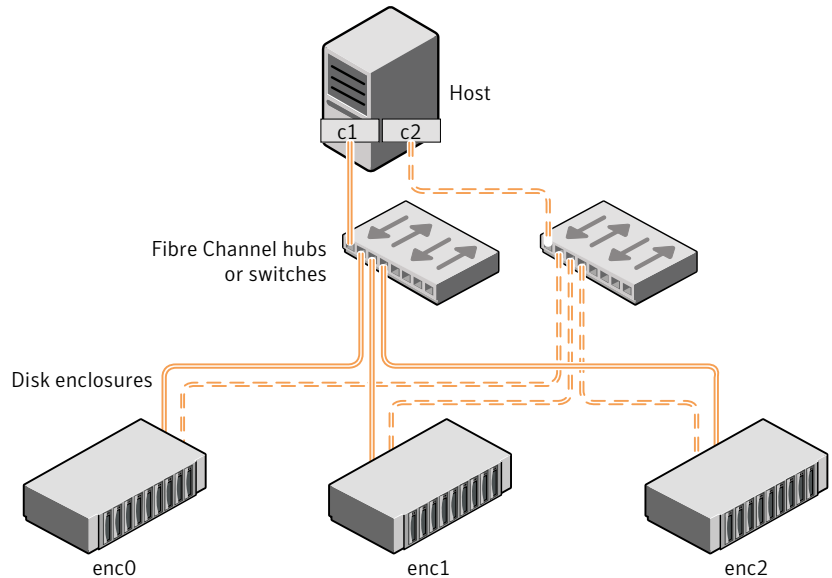

Such a configuration protects against the failure of one of the host controllers (c1 and c2), or of the cable between the host and one of the hubs. In this example, each disk is known by the same name to VxVM for all of the paths over which it can be accessed. For example, the disk device `enc0_0` represents a single disk for which two different paths are known to the operating system, such as `c1t99d0` and `c2t99d0`.

See “[Disk device naming in VxVM](#)” on page 83.

See “[Changing the disk-naming scheme](#)” on page 107.

To take account of fault domains when configuring data redundancy, you can control how mirrored volumes are laid out across enclosures.

See “[Mirroring across targets, controllers or enclosures](#)” on page 327.

## Virtual objects

VxVM uses multiple virtualization layers to provide distinct functionality and reduce physical limitations.

Virtual objects in VxVM include the following:

- Disk groups  
See “[Disk groups](#)” on page 31.
- VM disks  
See “[VM disks](#)” on page 32.
- Subdisks  
See “[Subdisks](#)” on page 33.
- Plexes  
See “[Plexes](#)” on page 34.
- Volumes  
See “[Volumes](#)” on page 35.

The connection between physical objects and VxVM objects is made when you place a physical disk under VxVM control.

After installing VxVM on a host system, you must bring the contents of physical disks under VxVM control by collecting the VM disks into disk groups and allocating the disk group space to create logical volumes.

Bringing the contents of physical disks under VxVM control is accomplished only if VxVM takes control of the physical disks and the disk is not under control of another storage manager such as Sun Microsystems Solaris Volume Manager software.

VxVM creates virtual objects and makes logical connections between the objects. The virtual objects are then used by VxVM to do storage management tasks.

The `vxprint` command displays detailed information about the VxVM objects that exist on a system.

See “[Displaying volume information](#)” on page 338.

See the `vxprint(1M)` manual page.

## Combining virtual objects in VxVM

VxVM virtual objects are combined to build volumes. The virtual objects contained in volumes are VM disks, disk groups, subdisks, and plexes. VxVM virtual objects are organized in the following ways:

- VM disks are grouped into disk groups
- Subdisks (each representing a specific region of a disk) are combined to form plexes
- Volumes are composed of one or more plexes

Figure 1-6 shows the connections between Veritas Volume Manager virtual objects and how they relate to physical disks.

**Figure 1-6** Connection between objects in VxVM

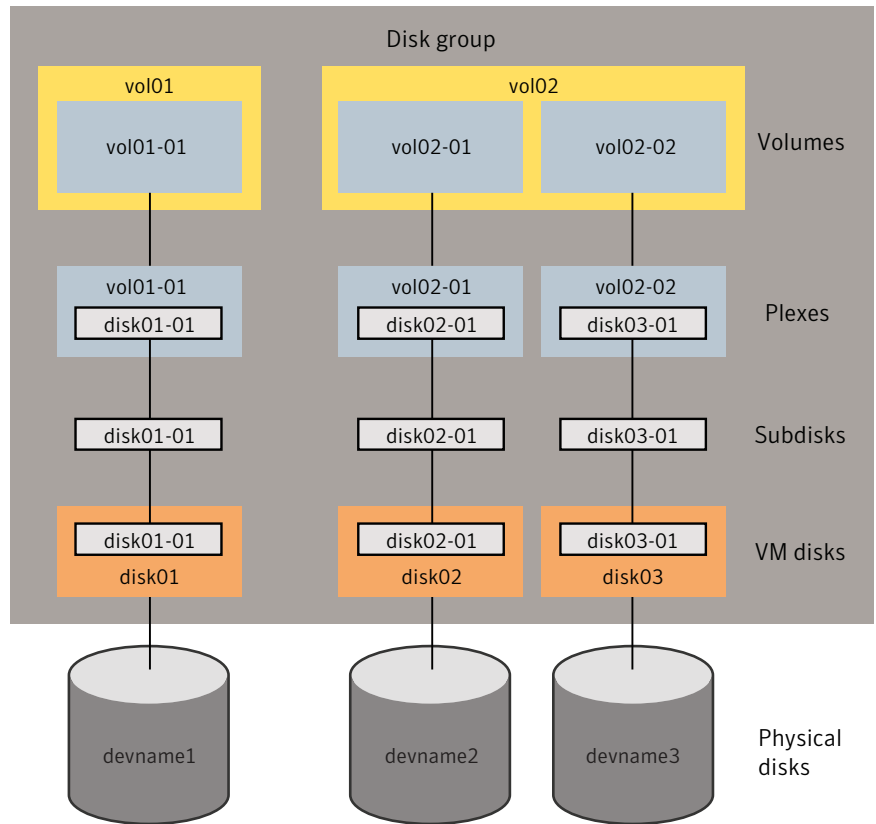

The disk group contains three VM disks which are used to create two volumes. Volume `vol01` is simple and has a single plex. Volume `vol02` is a mirrored volume with two plexes.

The various types of virtual objects (disk groups, VM disks, subdisks, plexes and volumes) are described in the following sections. Other types of objects exist in Veritas Volume Manager, such as data change objects (DCOs), and volume sets, to provide extended functionality.

### Disk groups

A disk group is a collection of disks that share a common configuration, and which are managed by VxVM. A disk group configuration is a set of records with detailed

information about related VxVM objects, their attributes, and their connections. A disk group name can be up to 31 characters long.

See “[VM disks](#)” on page 32.

In releases before VxVM 4.0, the default disk group was `rootdg` (the root disk group). For VxVM to function, the `rootdg` disk group had to exist and it had to contain at least one disk. This requirement no longer exists, and VxVM can work without any disk groups configured (although you must set up at least one disk group before you can create any volumes of other VxVM objects).

See “[System-wide reserved disk groups](#)” on page 222.

You can create additional disk groups when you need them. Disk groups allow you to group disks into logical collections. A disk group and its components can be moved as a unit from one host machine to another.

See “[Reorganizing the contents of disk groups](#)” on page 256.

Volumes are created within a disk group. A given volume and its plexes and subdisks must be configured from disks in the same disk group.

## VM disks

When you place a physical disk under VxVM control, a VM disk is assigned to the physical disk. A VM disk is under VxVM control and is usually in a disk group. Each VM disk corresponds to at least one physical disk or disk partition. VxVM allocates storage from a contiguous area of VxVM disk space.

A VM disk typically includes a public region (allocated storage) and a small private region where VxVM internal configuration information is stored.

Each VM disk has a unique disk media name (a virtual disk name). You can either define a disk name of up to 31 characters, or allow VxVM to assign a default name that takes the form `diskgroup##`, where *diskgroup* is the name of the disk group to which the disk belongs.

See “[Disk groups](#)” on page 31.

[Figure 1-7](#) shows a VM disk with a media name of `disk01` that is assigned to the physical disk, *devname*.



**Figure 1-7** VM disk example

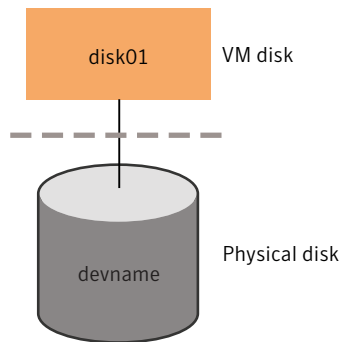

## Subdisks

A subdisk is a set of contiguous disk blocks. A block is a unit of space on the disk. VxVM allocates disk space using subdisks. A VM disk can be divided into one or more subdisks. Each subdisk represents a specific portion of a VM disk, which is mapped to a specific region of a physical disk.

The default name for a VM disk is `diskgroup##` and the default name for a subdisk is `diskgroup##-##`, where *diskgroup* is the name of the disk group to which the disk belongs.

See “Disk groups” on page 31.

Figure 1-8 shows `disk01-01` is the name of the first subdisk on the VM disk named `disk01`.

**Figure 1-8** Subdisk example

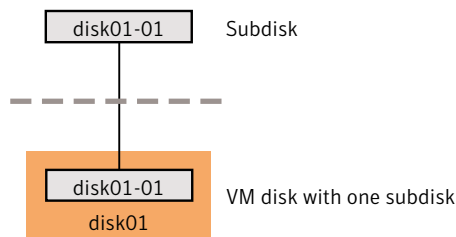

A VM disk can contain multiple subdisks, but subdisks cannot overlap or share the same portions of a VM disk. To ensure integrity, VxVM rejects any commands that try to create overlapping subdisks.

Figure 1-9 shows a VM disk with three subdisks, which are assigned from one physical disk.

**Figure 1-9** Example of three subdisks assigned to one VM Disk

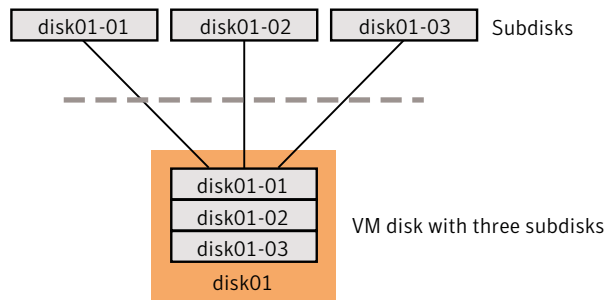

Any VM disk space that is not part of a subdisk is free space. You can use free space to create new subdisks.

## Plexes

VxVM uses subdisks to build virtual objects called plexes. A plex consists of one or more subdisks located on one or more physical disks.

[Figure 1-10](#) shows an example of a plex with two subdisks.

**Figure 1-10** Example of a plex with two subdisks

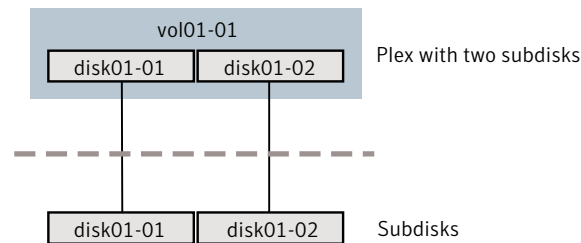

You can organize data on subdisks to form a plex by using the following methods:

- concatenation
- striping (RAID-0)
- mirroring (RAID-1)
- striping with parity (RAID-5)

Concatenation, striping (RAID-0), mirroring (RAID-1) and RAID-5 are types of volume layout.

See [“Volume layouts in VxVM”](#) on page 36.

## Volumes

A volume is a virtual disk device that appears to applications, databases, and file systems like a physical disk device, but does not have the physical limitations of a physical disk device. A volume consists of one or more plexes, each holding a copy of the selected data in the volume. Due to its virtual nature, a volume is not restricted to a particular disk or a specific area of a disk. The configuration of a volume can be changed by using VxVM user interfaces. Configuration changes can be accomplished without causing disruption to applications or file systems that are using the volume. For example, a volume can be mirrored on separate disks or moved to use different disk storage.

VxVM uses the default naming conventions of `vol##` for volumes and `vol##-##` for plexes in a volume. For ease of administration, you can choose to select more meaningful names for the volumes that you create.

A volume may be created under the following constraints:

- Its name can contain up to 31 characters.
- It can consist of up to 32 plexes, each of which contains one or more subdisks.
- It must have at least one associated plex that has a complete copy of the data in the volume with at least one associated subdisk.
- All subdisks within a volume must belong to the same disk group.

Figure 1-11 shows a volume `vol01` with a single plex.

**Figure 1-11** Example of a volume with one plex

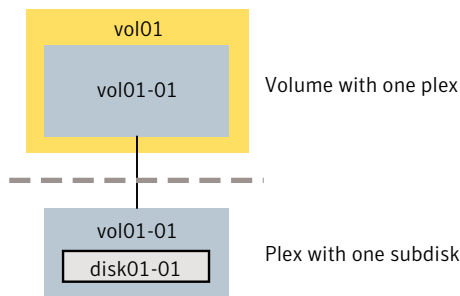

The volume `vol01` has the following characteristics:

- It contains one plex named `vol01-01`.
- The plex contains one subdisk named `disk01-01`.
- The subdisk `disk01-01` is allocated from VM disk `disk01`.

Figure 1-12 shows a mirrored volume, `vol06`, with two data plexes.

Figure 1-12 Example of a volume with two plexes

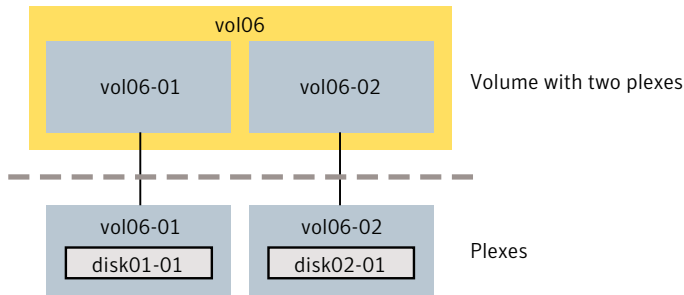

Each plex of the mirror contains a complete copy of the volume data.

The volume `vol06` has the following characteristics:

- It contains two plexes named `vol06-01` and `vol06-02`.
- Each plex contains one subdisk.
- Each subdisk is allocated from a different VM disk (`disk01` and `disk02`).

See “[Mirroring \(RAID-1\)](#)” on page 43.

VxVM supports the concept of layered volumes in which subdisks can contain volumes.

See “[Layered volumes](#)” on page 51.

## Volume layouts in VxVM

A VxVM virtual device is defined by a volume. A volume has a layout defined by the association of a volume to one or more plexes, each of which map to one or more subdisks. The volume presents a virtual device interface that is exposed to other applications for data access. These logical building blocks re-map the volume address space through which I/O is re-directed at run-time.

Different volume layouts provide different levels of availability and performance. A volume layout can be configured and changed to provide the desired level of service.

### Non-layered volumes

In a non-layered volume, a subdisk maps directly to a VM disk. This allows the subdisk to define a contiguous extent of storage space backed by the public region of a VM disk. When active, the VM disk is directly associated with an underlying

physical disk. The combination of a volume layout and the physical disks therefore determines the storage service available from a given virtual device.

## Layered volumes

A layered volume is constructed by mapping its subdisks to underlying volumes. The subdisks in the underlying volumes must map to VM disks, and hence to attached physical storage.

Layered volumes allow for more combinations of logical compositions, some of which may be desirable for configuring a virtual device. For example, layered volumes allow for high availability when using striping. Because permitting free use of layered volumes throughout the command level would have resulted in unwieldy administration, some ready-made layered volume configurations are designed into VxVM.

See “[Layered volumes](#)” on page 51.

These ready-made configurations operate with built-in rules to automatically match desired levels of service within specified constraints. The automatic configuration is done on a “best-effort” basis for the current command invocation working against the current configuration.

To achieve the desired storage service from a set of virtual devices, it may be necessary to include an appropriate set of VM disks into a disk group, and to execute multiple configuration commands.

To the extent that it can, VxVM handles initial configuration and on-line re-configuration with its set of layouts and administration interface to make this job easier and more deterministic.

## Layout methods

Data in virtual objects is organized to create volumes by using the following layout methods:

- Concatenation, spanning, and carving  
See “[Concatenation, spanning, and carving](#)” on page 38.
- Striping (RAID-0)  
See “[Striping \(RAID-0\)](#)” on page 40.
- Mirroring (RAID-1)  
See “[Mirroring \(RAID-1\)](#)” on page 43.
- Striping plus mirroring (mirrored-stripe or RAID-0+1)  
See “[Striping plus mirroring \(mirrored-stripe or RAID-0+1\)](#)” on page 44.
- Mirroring plus striping (striped-mirror, RAID-1+0 or RAID-10)

See “[Mirroring plus striping \(striped-mirror, RAID-1+0 or RAID-10\)](#)” on page 45.

- RAID-5 (striping with parity)  
See “[RAID-5 \(striping with parity\)](#)” on page 46.

## Concatenation, spanning, and carving

Concatenation maps data in a linear manner onto one or more subdisks in a plex. To access all of the data in a concatenated plex sequentially, data is first accessed in the first subdisk from beginning to end. Data is then accessed in the remaining subdisks sequentially from beginning to end, until the end of the last subdisk.

The subdisks in a concatenated plex do not have to be physically contiguous and can belong to more than one VM disk. Concatenation using subdisks that reside on more than one VM disk is called spanning.

[Figure 1-13](#) shows the concatenation of two subdisks from the same VM disk.

If a single LUN or disk is split into multiple subdisks, and each subdisk belongs to a unique volume, this is called carving.

**Figure 1-13** Example of concatenation

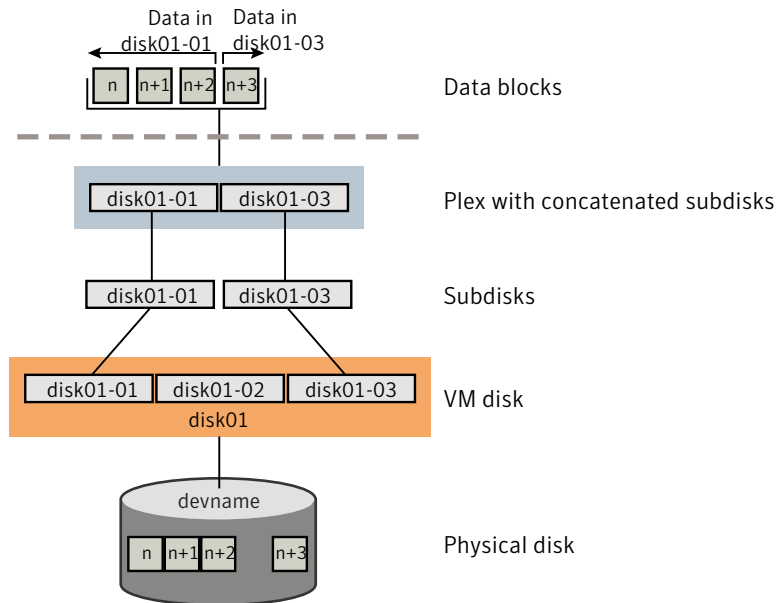

The blocks  $n$ ,  $n+1$ ,  $n+2$  and  $n+3$  (numbered relative to the start of the plex) are contiguous on the plex, but actually come from two distinct subdisks on the same physical disk.

The remaining free space in the subdisk, `disk01-02`, on VM disk, `disk01`, can be put to other uses.

You can use concatenation with multiple subdisks when there is insufficient contiguous space for the plex on any one disk. This form of concatenation can be used for load balancing between disks, and for head movement optimization on a particular disk.

Figure 1-14 shows data spread over two subdisks in a spanned plex.

**Figure 1-14** Example of spanning

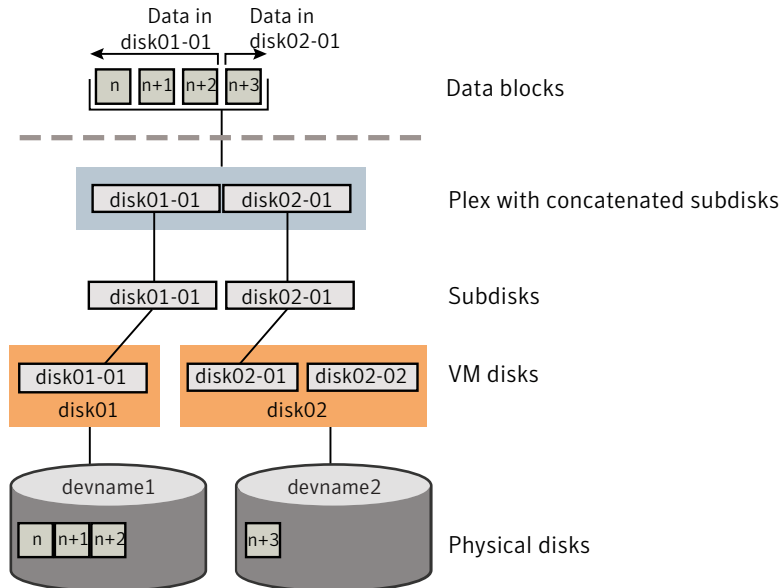

The blocks  $n$ ,  $n+1$ ,  $n+2$  and  $n+3$  (numbered relative to the start of the plex) are contiguous on the plex, but actually come from two distinct subdisks from two distinct physical disks.

The remaining free space in the subdisk `disk02-02` on VM disk `disk02` can be put to other uses.

---

**Warning:** Spanning a plex across multiple disks increases the chance that a disk failure results in failure of the assigned volume. Use mirroring or RAID-5 to reduce the risk that a single disk failure results in a volume failure.

---

## Striping (RAID-0)

Striping (RAID-0) is useful if you need large amounts of data written to or read from physical disks, and performance is important. Striping is also helpful in balancing the I/O load from multi-user applications across multiple disks. By using parallel data transfer to and from multiple disks, striping significantly improves data-access performance.

Striping maps data so that the data is interleaved among two or more physical disks. A striped plex contains two or more subdisks, spread out over two or more physical disks. Data is allocated alternately and evenly to the subdisks of a striped plex.

The subdisks are grouped into “columns,” with each physical disk limited to one column. Each column contains one or more subdisks and can be derived from one or more physical disks. The number and sizes of subdisks per column can vary. Additional subdisks can be added to columns, as necessary.

---

**Warning:** Striping a volume, or splitting a volume across multiple disks, increases the chance that a disk failure will result in failure of that volume.

---

If five volumes are striped across the same five disks, then failure of any one of the five disks will require that all five volumes be restored from a backup. If each volume is on a separate disk, only one volume has to be restored. (As an alternative to or in conjunction with striping, use mirroring or RAID-5 to substantially reduce the chance that a single disk failure results in failure of a large number of volumes.)

Data is allocated in equal-sized stripe units that are interleaved between the columns. Each stripe unit is a set of contiguous blocks on a disk. The default stripe unit size is 64 kilobytes.

[Figure 1-15](#) shows an example with three columns in a striped plex, six stripe units, and data striped over the three columns.



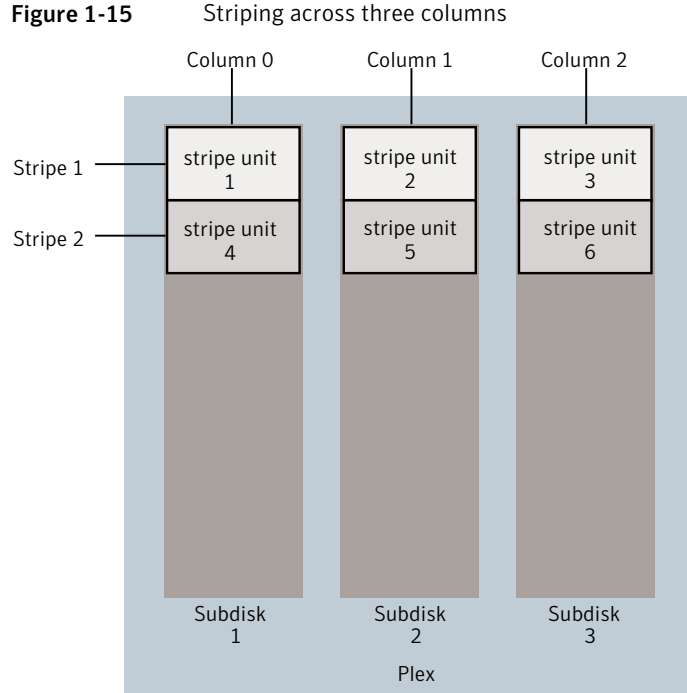

A stripe consists of the set of stripe units at the same positions across all columns. In the figure, stripe units 1, 2, and 3 constitute a single stripe.

Viewed in sequence, the first stripe consists of:

- stripe unit 1 in column 0
- stripe unit 2 in column 1
- stripe unit 3 in column 2

The second stripe consists of:

- stripe unit 4 in column 0
- stripe unit 5 in column 1
- stripe unit 6 in column 2

Striping continues for the length of the columns (if all columns are the same length), or until the end of the shortest column is reached. Any space remaining at the end of subdisks in longer columns becomes unused space.

[Figure 1-16](#) shows a striped plex with three equal sized, single-subdisk columns.

**Figure 1-16** Example of a striped plex with one subdisk per column

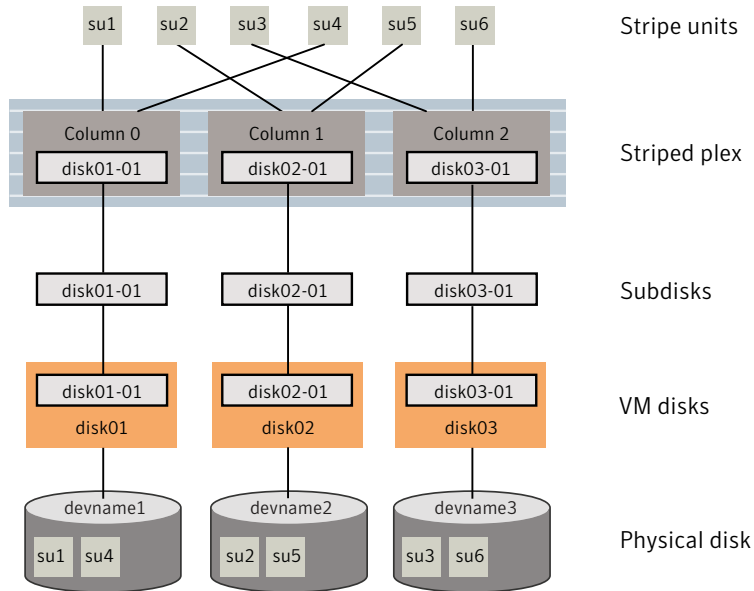

There is one column per physical disk. This example shows three subdisks that occupy all of the space on the VM disks. It is also possible for each subdisk in a striped plex to occupy only a portion of the VM disk, which leaves free space for other disk management tasks.

[Figure 1-17](#) shows a striped plex with three columns containing subdisks of different sizes.

**Figure 1-17** Example of a striped plex with concatenated subdisks per column

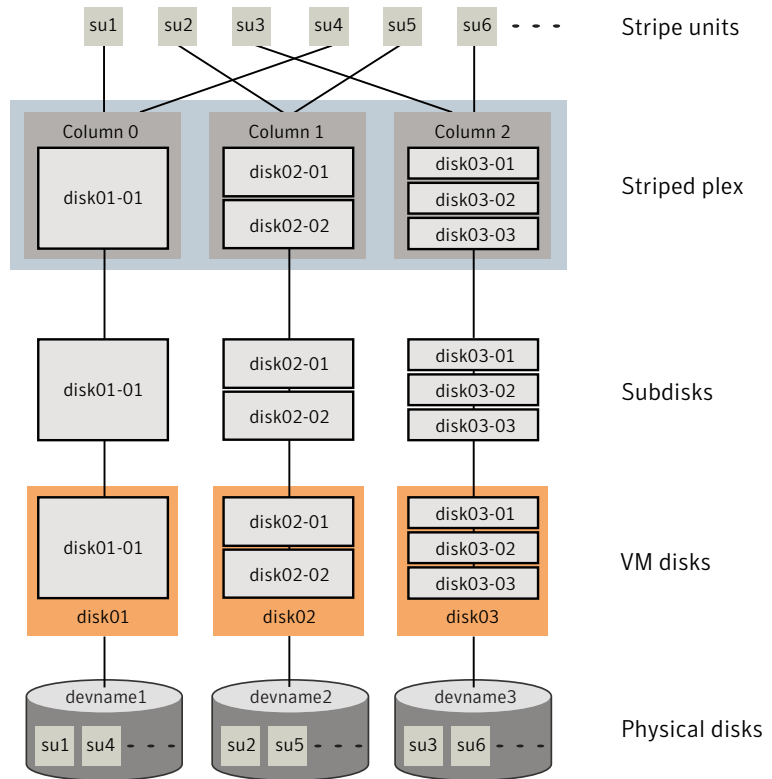

Each column contains a different number of subdisks. There is one column per physical disk. Striped plexes can be created by using a single subdisk from each of the VM disks being striped across. It is also possible to allocate space from different regions of the same disk or from another disk (for example, if the size of the plex is increased). Columns can also contain subdisks from different VM disks.

See [“Creating a striped volume”](#) on page 325.

## Mirroring (RAID-1)

Mirroring uses multiple mirrors (plexes) to duplicate the information contained in a volume. In the event of a physical disk failure, the plex on the failed disk becomes unavailable, but the system continues to operate using the unaffected mirrors. Similarly, mirroring two LUNs from two separate controllers lets the system operate if there is a controller failure.

Although a volume can have a single plex, at least two plexes are required to provide redundancy of data. Each of these plexes must contain disk space from different disks to achieve redundancy.

When striping or spanning across a large number of disks, failure of any one of those disks can make the entire plex unusable. Because the likelihood of one out of several disks failing is reasonably high, you should consider mirroring to improve the reliability (and availability) of a striped or spanned volume.

See [“Creating a mirrored volume”](#) on page 319.

See [“Mirroring across targets, controllers or enclosures”](#) on page 327.

## Striping plus mirroring (mirrored-stripe or RAID-0+1)

VxVM supports the combination of mirroring above striping. The combined layout is called a mirrored-stripe layout. A mirrored-stripe layout offers the dual benefits of striping to spread data across multiple disks, while mirroring provides redundancy of data.

For mirroring above striping to be effective, the striped plex and its mirrors must be allocated from separate disks.

[Figure 1-18](#) shows an example where two plexes, each striped across three disks, are attached as mirrors to the same volume to create a mirrored-stripe volume.

**Figure 1-18** Mirrored-stripe volume laid out on six disks

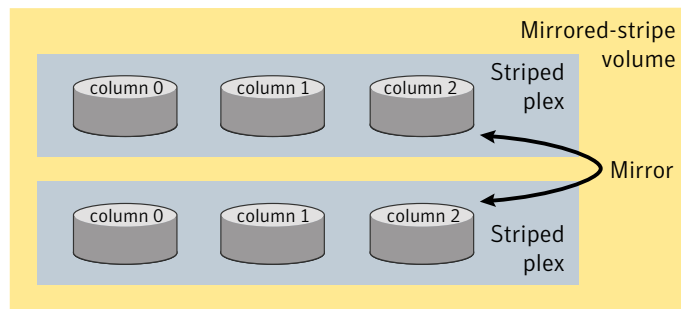

See [“Creating a mirrored-stripe volume”](#) on page 326.

The layout type of the data plexes in a mirror can be concatenated or striped. Even if only one is striped, the volume is still termed a mirrored-stripe volume. If they are all concatenated, the volume is termed a mirrored-concatenated volume.

## Mirroring plus striping (striped-mirror, RAID-1+0 or RAID-10)

VxVM supports the combination of striping above mirroring. This combined layout is called a striped-mirror layout. Putting mirroring below striping mirrors each column of the stripe. If there are multiple subdisks per column, each subdisk can be mirrored individually instead of each column.

A striped-mirror volume is an example of a layered volume.

See [“Layered volumes”](#) on page 51.

As for a mirrored-stripe volume, a striped-mirror volume offers the dual benefits of striping to spread data across multiple disks, while mirroring provides redundancy of data. In addition, it enhances redundancy, and reduces recovery time after disk failure.

[Figure 1-19](#) shows an example where a striped-mirror volume is created by using each of three existing 2-disk mirrored volumes to form a separate column within a striped plex.

**Figure 1-19** Striped-mirror volume laid out on six disks

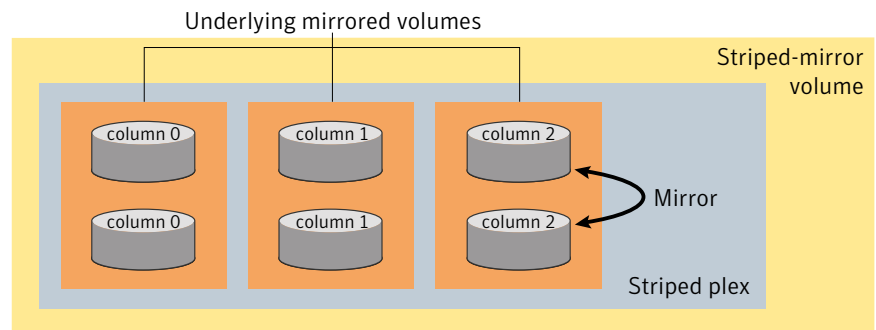

See [“Creating a striped-mirror volume”](#) on page 327.

[Figure 1-20](#) shows that the failure of a disk in a mirrored-stripe layout detaches an entire data plex, thereby losing redundancy on the entire volume.

**Figure 1-20** How the failure of a single disk affects mirrored-stripe and striped-mirror volumes

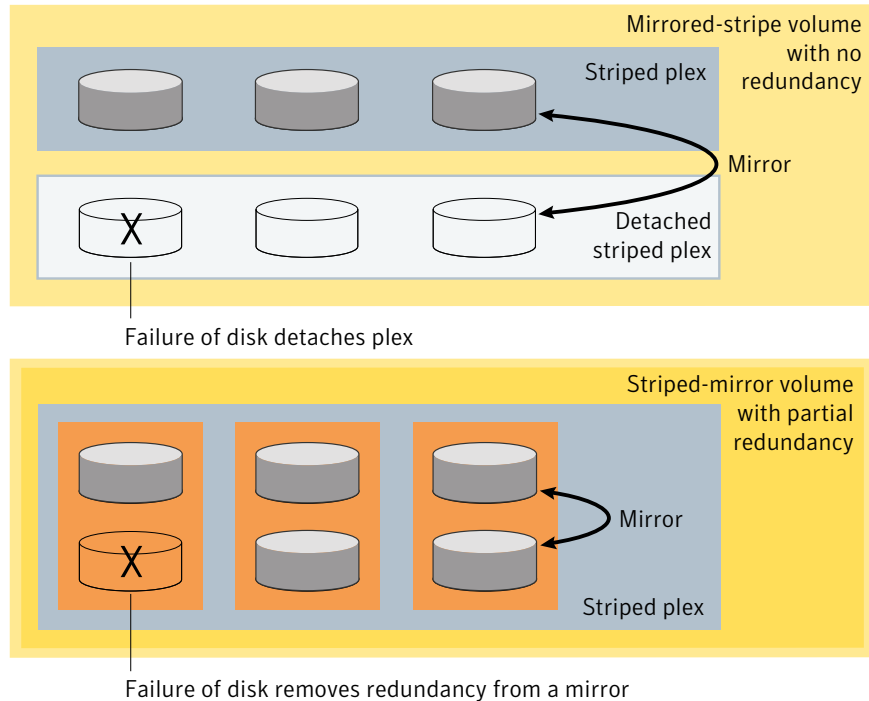

When the disk is replaced, the entire plex must be brought up to date. Recovering the entire plex can take a substantial amount of time. If a disk fails in a striped-mirror layout, only the failing subdisk must be detached, and only that portion of the volume loses redundancy. When the disk is replaced, only a portion of the volume needs to be recovered. Additionally, a mirrored-stripe volume is more vulnerable to being put out of use altogether should a second disk fail before the first failed disk has been replaced, either manually or by hot-relocation.

Compared to mirrored-stripe volumes, striped-mirror volumes are more tolerant of disk failure, and recovery time is shorter.

If the layered volume concatenates instead of striping the underlying mirrored volumes, the volume is termed a concatenated-mirror volume.

## RAID-5 (striping with parity)

Although both mirroring (RAID-1) and RAID-5 provide redundancy of data, they use different methods. Mirroring provides data redundancy by maintaining multiple complete copies of the data in a volume. Data being written to a mirrored

volume is reflected in all copies. If a portion of a mirrored volume fails, the system continues to use the other copies of the data.

RAID-5 provides data redundancy by using parity. Parity is a calculated value used to reconstruct data after a failure. While data is being written to a RAID-5 volume, parity is calculated by doing an exclusive OR (XOR) procedure on the data. The resulting parity is then written to the volume. The data and calculated parity are contained in a plex that is “striped” across multiple disks. If a portion of a RAID-5 volume fails, the data that was on that portion of the failed volume can be recreated from the remaining data and parity information. It is also possible to mix concatenation and striping in the layout.

Figure 1-21 shows parity locations in a RAID-5 array configuration.

**Figure 1-21** Parity locations in a RAID-5 model

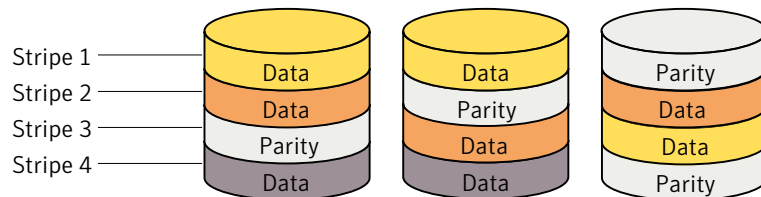

Every stripe has a column containing a parity stripe unit and columns containing data. The parity is spread over all of the disks in the array, reducing the write time for large independent writes because the writes do not have to wait until a single parity disk can accept the data.

RAID-5 volumes can additionally perform logging to minimize recovery time. RAID-5 volumes use RAID-5 logs to keep a copy of the data and parity currently being written. RAID-5 logging is optional and can be created along with RAID-5 volumes or added later.

See “[Veritas Volume Manager RAID-5 arrays](#)” on page 48.

---

**Note:** VxVM supports RAID-5 for private disk groups, but not for shareable disk groups in a CVM environment. In addition, VxVM does not support the mirroring of RAID-5 volumes that are configured using Veritas Volume Manager software. RAID-5 LUNs hardware may be mirrored.

---

## Traditional RAID-5 arrays

A traditional RAID-5 array is several disks organized in rows and columns. A column is a number of disks located in the same ordinal position in the array. A

row is the minimal number of disks necessary to support the full width of a parity stripe.

Figure 1-22 shows the row and column arrangement of a traditional RAID-5 array.

Figure 1-22 Traditional RAID-5 array

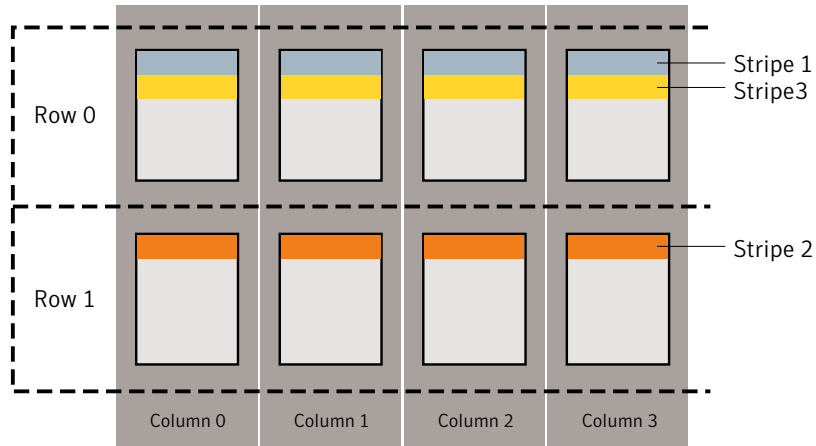

This traditional array structure supports growth by adding more rows per column. Striping is accomplished by applying the first stripe across the disks in Row 0, then the second stripe across the disks in Row 1, then the third stripe across the Row 0 disks, and so on. This type of array requires all disks columns, and rows to be of equal size.

## Veritas Volume Manager RAID-5 arrays

The RAID-5 array structure in Veritas Volume Manager differs from the traditional structure. Due to the virtual nature of its disks and other objects, VxVM does not use rows.

Figure 1-23 shows how VxVM uses columns consisting of variable length subdisks, where each subdisk represents a specific area of a disk.

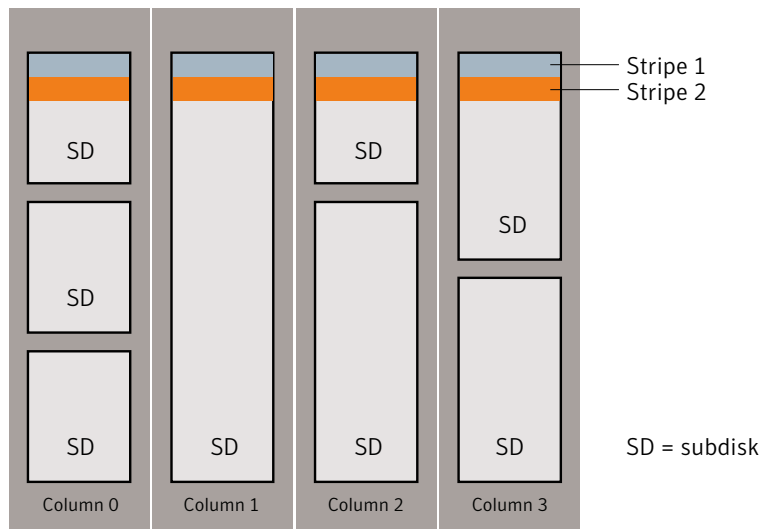

**Figure 1-23** Veritas Volume Manager RAID-5 array

VxVM allows each column of a RAID-5 plex to consist of a different number of subdisks. The subdisks in a given column can be derived from different physical disks. Additional subdisks can be added to the columns as necessary. Striping is implemented by applying the first stripe across each subdisk at the top of each column, then applying another stripe below that, and so on for the length of the columns. Equal-sized stripe units are used for each column. For RAID-5, the default stripe unit size is 16 kilobytes.

See [“Striping \(RAID-0\)”](#) on page 40.

---

**Note:** Mirroring of RAID-5 volumes is not supported.

---

See [“Creating a RAID-5 volume”](#) on page 329.

## Left-symmetric layout

There are several layouts for data and parity that can be used in the setup of a RAID-5 array. The implementation of RAID-5 in VxVM uses a left-symmetric layout. This provides optimal performance for both random I/O operations and large sequential I/O operations. However, the layout selection is not as critical for performance as are the number of columns and the stripe unit size.

Left-symmetric layout stripes both data and parity across columns, placing the parity in a different column for every stripe of data. The first parity stripe unit is located in the rightmost column of the first stripe. Each successive parity stripe

unit is located in the next stripe, shifted left one column from the previous parity stripe unit location. If there are more stripes than columns, the parity stripe unit placement begins in the rightmost column again.

Figure 1-24 shows a left-symmetric parity layout with five disks (one per column).

Figure 1-24 Left-symmetric layout

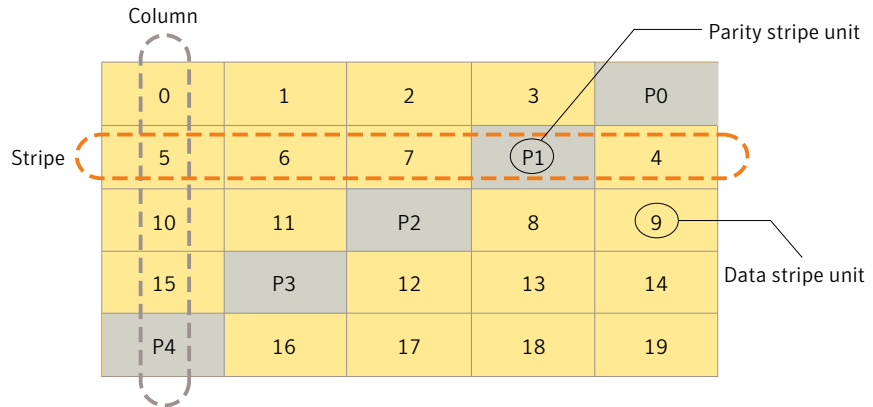

For each stripe, data is organized starting to the right of the parity stripe unit. In the figure, data organization for the first stripe begins at P0 and continues to stripe units 0-3. Data organization for the second stripe begins at P1, then continues to stripe unit 4, and on to stripe units 5-7. Data organization proceeds in this manner for the remaining stripes.

Each parity stripe unit contains the result of an exclusive OR (XOR) operation performed on the data in the data stripe units within the same stripe. If one column's data is inaccessible due to hardware or software failure, the data for each stripe can be restored by XORing the contents of the remaining columns data stripe units against their respective parity stripe units.

For example, if a disk corresponding to the whole or part of the far left column fails, the volume is placed in a degraded mode. While in degraded mode, the data from the failed column can be recreated by XORing stripe units 1-3 against parity stripe unit P0 to recreate stripe unit 0, then XORing stripe units 4, 6, and 7 against parity stripe unit P1 to recreate stripe unit 5, and so on.

Failure of more than one column in a RAID-5 plex detaches the volume. The volume is no longer allowed to satisfy read or write requests. Once the failed columns have been recovered, it may be necessary to recover user data from backups.

## RAID-5 logging

Logging is used to prevent corruption of data during recovery by immediately recording changes to data and parity to a log area on a persistent device such as a volume on disk or in non-volatile RAM. The new data and parity are then written to the disks.

Without logging, it is possible for data not involved in any active writes to be lost or silently corrupted if both a disk in a RAID-5 volume and the system fail. If this double-failure occurs, there is no way of knowing if the data being written to the data portions of the disks or the parity being written to the parity portions have actually been written. Therefore, the recovery of the corrupted disk may be corrupted itself.

Figure 1-25 shows a RAID-5 volume configured across three disks (A, B and C).

**Figure 1-25** Incomplete write to a RAID-5 volume

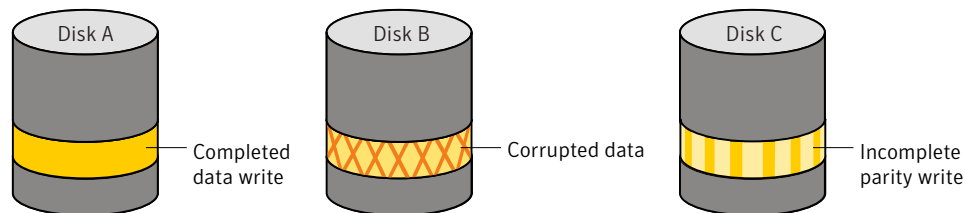

In this volume, recovery of disk B's corrupted data depends on disk A's data and disk C's parity both being complete. However, only the data write to disk A is complete. The parity write to disk C is incomplete, which would cause the data on disk B to be reconstructed incorrectly.

This failure can be avoided by logging all data and parity writes before committing them to the array. In this way, the log can be replayed, causing the data and parity updates to be completed before the reconstruction of the failed drive takes place.

Logs are associated with a RAID-5 volume by being attached as log plexes. More than one log plex can exist for each RAID-5 volume, in which case the log areas are mirrored.

See “[Adding a RAID-5 log](#)” on page 384.

## Layered volumes

A layered volume is a virtual Veritas Volume Manager object that is built on top of other volumes. The layered volume structure tolerates failure better and has greater redundancy than the standard volume structure. For example, in a striped-mirror layered volume, each mirror (plex) covers a smaller area of storage space, so recovery is quicker than with a standard mirrored volume.

Figure 1-26 shows a typical striped-mirror layered volume where each column is represented by a subdisk that is built from an underlying mirrored volume.

**Figure 1-26** Example of a striped-mirror layered volume

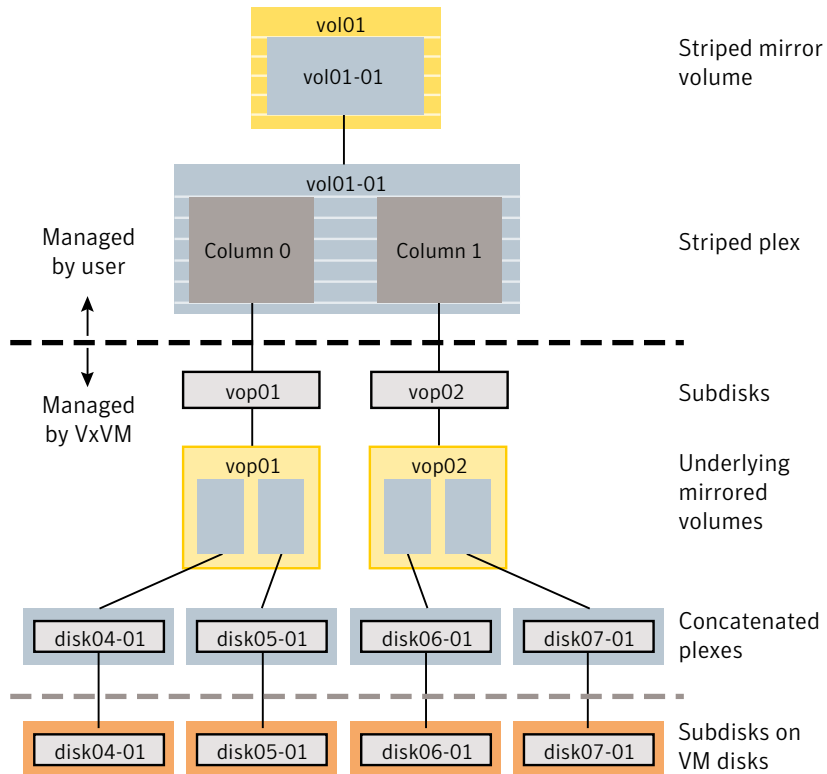

The volume and striped plex in the “Managed by User” area allow you to perform normal tasks in VxVM. User tasks can be performed only on the top-level volume of a layered volume.

Underlying volumes in the “Managed by VxVM” area are used exclusively by VxVM and are not designed for user manipulation. You cannot detach a layered volume or perform any other operation on the underlying volumes by manipulating the internal structure. You can perform all necessary operations in the “Managed by User” area that includes the top-level volume and striped plex (for example, resizing the volume, changing the column width, or adding a column).

System administrators can manipulate the layered volume structure for troubleshooting or other operations (for example, to place data on specific disks). Layered volumes are used by VxVM to perform the following tasks and operations:

Creating striped-mirrors	See <a href="#">“Creating a striped-mirror volume”</a> on page 327. See the <code>vxassist(1M)</code> manual page.
Creating concatenated-mirrors	See <a href="#">“Creating a concatenated-mirror volume”</a> on page 320. See the <code>vxassist(1M)</code> manual page.
Online Relayout	See <a href="#">“Online relayout”</a> on page 53. See the <code>vxassist(1M)</code> manual page. See the <code>vxrelayout(1M)</code> manual page.
Moving RAID-5 subdisks	See the <code>vxsd(1M)</code> manual page.
Creating Snapshots	See <a href="#">“About volume snapshots”</a> on page 387. See the <code>vxassist(1M)</code> manual page. See the <code>vxsnap(1M)</code> manual page.

## Online relayout

Online relayout allows you to convert between storage layouts in VxVM, with uninterrupted data access. Typically, you would do this to change the redundancy or performance characteristics of a volume. VxVM adds redundancy to storage either by duplicating the data (mirroring) or by adding parity (RAID-5). Performance characteristics of storage in VxVM can be changed by changing the striping parameters, which are the number of columns and the stripe width.

See [“Performing online relayout”](#) on page 376.

See [“Converting between layered and non-layered volumes”](#) on page 383.

## How online relayout works

Online relayout allows you to change the storage layouts that you have already created in place without disturbing data access. You can change the performance characteristics of a particular layout to suit your changed requirements. You can transform one layout to another by invoking a single command.

For example, if a striped layout with a 128KB stripe unit size is not providing optimal performance, you can use `relayout` to change the stripe unit size.

File systems mounted on the volumes do not need to be unmounted to achieve this transformation provided that the file system (such as Veritas File System) supports online shrink and grow operations.

Online relayout reuses the existing storage space and has space allocation policies to address the needs of the new layout. The layout transformation process converts a given volume to the destination layout by using minimal temporary space that is available in the disk group.

The transformation is done by moving one portion of data at a time in the source layout to the destination layout. Data is copied from the source volume to the temporary area, and data is removed from the source volume storage area in portions. The source volume storage area is then transformed to the new layout, and the data saved in the temporary area is written back to the new layout. This operation is repeated until all the storage and data in the source volume has been transformed to the new layout.

The default size of the temporary area used during the relayout depends on the size of the volume and the type of relayout. For volumes larger than 50MB, the amount of temporary space that is required is usually 10% of the size of the volume, from a minimum of 50MB up to a maximum of 1GB. For volumes smaller than 50MB, the temporary space required is the same as the size of the volume.

The following error message displays the number of blocks required if there is insufficient free space available in the disk group for the temporary area:

```
tmpsize too small to perform this relayout (nblks minimum required)
```

You can override the default size used for the temporary area by using the `tmpsize` attribute to `vxassist`.

See the `vxassist(1M)` manual page.

As well as the temporary area, space is required for a temporary intermediate volume when increasing the column length of a striped volume. The amount of space required is the difference between the column lengths of the target and source volumes. For example, 20GB of temporary additional space is required to relayout a 150GB striped volume with 5 columns of length 30GB as 3 columns of length 50GB. In some cases, the amount of temporary space that is required is relatively large. For example, a relayout of a 150GB striped volume with 5 columns as a concatenated volume (with effectively one column) requires 120GB of space for the intermediate volume.

Additional permanent disk space may be required for the destination volumes, depending on the type of relayout that you are performing. This may happen, for example, if you change the number of columns in a striped volume.

[Figure 1-27](#) shows how decreasing the number of columns can require disks to be added to a volume.

**Figure 1-27** Example of decreasing the number of columns in a volume

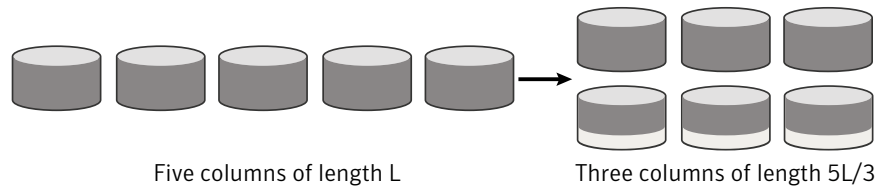

Note that the size of the volume remains the same but an extra disk is needed to extend one of the columns.

The following are examples of operations that you can perform using online relayout:

- Remove parity from a RAID-5 volume to change it to a concatenated, striped, or layered volume.

Figure 1-28 shows an example of applying relayout a RAID-5 volume.

**Figure 1-28** Example of relayout of a RAID-5 volume to a striped volume

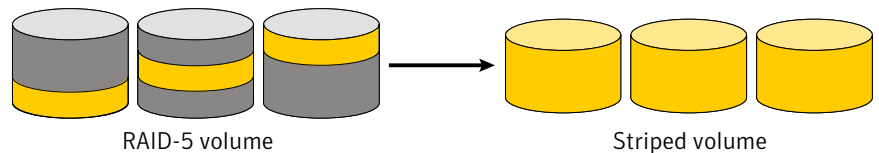

Note that removing parity decreases the overall storage space that the volume requires.

- Add parity to a volume to change it to a RAID-5 volume.

Figure 1-29 shows an example.

**Figure 1-29** Example of relayout of a concatenated volume to a RAID-5 volume

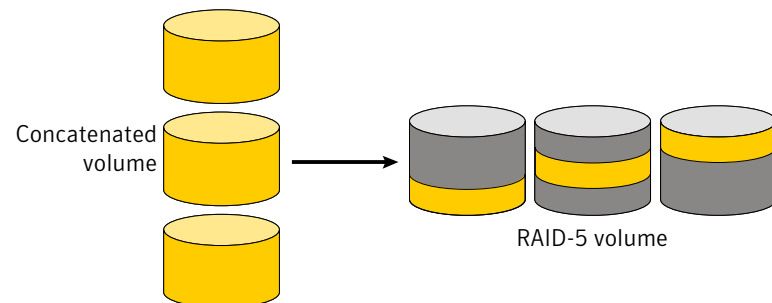

Note that adding parity increases the overall storage space that the volume requires.

- Change the number of columns in a volume.  
[Figure 1-30](#) shows an example of changing the number of columns.

**Figure 1-30** Example of increasing the number of columns in a volume

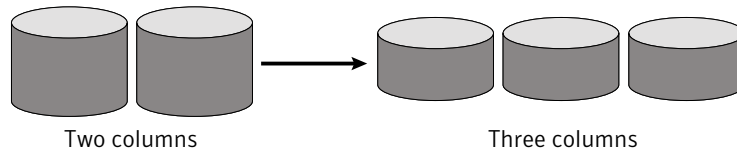

Note that the length of the columns is reduced to conserve the size of the volume.

- Change the column stripe width in a volume.  
[Figure 1-31](#) shows an example of changing the column stripe width.

**Figure 1-31** Example of increasing the stripe width for the columns in a volume

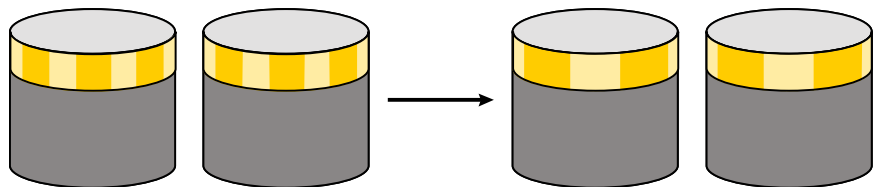

See [“Performing online relayout”](#) on page 376.

See [“Permitted relayout transformations”](#) on page 376.

## Limitations of online relayout

Note the following limitations of online relayout:

- Log plexes cannot be transformed.
- Volume snapshots cannot be taken when there is an online relayout operation running on the volume.
- Online relayout cannot create a non-layered mirrored volume in a single step. It always creates a layered mirrored volume even if you specify a non-layered mirrored layout, such as `mirror-stripe` or `mirror-concat`. Use the `vxassist convert` command to turn the layered mirrored volume that results from a relayout into a non-layered volume.  
See [“Converting between layered and non-layered volumes”](#) on page 383.
- Online relayout can only be used with volumes that have been created using the `vxassist` command, Storage Foundation Manager (SFM), or the Veritas Enterprise Administrator (VEA).



- The usual restrictions apply for the minimum number of physical disks that are required to create the destination layout. For example, mirrored volumes require at least as many disks as mirrors, striped and RAID-5 volumes require at least as many disks as columns, and striped-mirror volumes require at least as many disks as columns multiplied by mirrors.
- To be eligible for layout transformation, the plexes in a mirrored volume must have identical stripe widths and numbers of columns. Relayout is not possible unless you make the layouts of the individual plexes identical.
- Online relayout cannot transform sparse plexes, nor can it make any plex sparse. (A sparse plex is a plex that is not the same size as the volume, or that has regions that are not mapped to any subdisk.)
- The number of mirrors in a mirrored volume cannot be changed using relayout. Use alternative commands instead.
- Only one relayout may be applied to a volume at a time.

## Transformation characteristics

Transformation of data from one layout to another involves rearrangement of data in the existing layout to the new layout. During the transformation, online relayout retains data redundancy by mirroring any temporary space used. Read and write access to data is not interrupted during the transformation.

Data is not corrupted if the system fails during a transformation. The transformation continues after the system is restored and both read and write access are maintained.

You can reverse the layout transformation process at any time, but the data may not be returned to the exact previous storage location. Before you reverse a transformation that is in process, you must stop it.

You can determine the transformation direction by using the `vxrelayout status volume` command.

These transformations are protected against I/O failures if there is sufficient redundancy and space to move the data.

## Transformations and volume length

Some layout transformations can cause the volume length to increase or decrease. If either of these conditions occurs, online relayout uses the `vxresize` command to shrink or grow a file system.

See [“Resizing a volume”](#) on page 351.

## Volume resynchronization

When storing data redundantly and using mirrored or RAID-5 volumes, VxVM ensures that all copies of the data match exactly. However, under certain conditions (usually due to complete system failures), some redundant data on a volume can become inconsistent or unsynchronized. The mirrored data is not exactly the same as the original data. Except for normal configuration changes (such as detaching and reattaching a plex), this can only occur when a system crashes while data is being written to a volume.

Data is written to the mirrors of a volume in parallel, as is the data and parity in a RAID-5 volume. If a system crash occurs before all the individual writes complete, it is possible for some writes to complete while others do not. This can result in the data becoming unsynchronized. For mirrored volumes, it can cause two reads from the same region of the volume to return different results, if different mirrors are used to satisfy the read request. In the case of RAID-5 volumes, it can lead to parity corruption and incorrect data reconstruction.

VxVM ensures that all mirrors contain exactly the same data and that the data and parity in RAID-5 volumes agree. This process is called volume resynchronization. For volumes that are part of the disk group that is automatically imported at boot time (usually aliased as the reserved system-wide disk group, `bootdg`), resynchronization takes place when the system reboots.

Not all volumes require resynchronization after a system failure. Volumes that were never written or that were quiescent (that is, had no active I/O) when the system failure occurred could not have had outstanding writes and do not require resynchronization.

### Dirty flags

VxVM records when a volume is first written to and marks it as dirty. When a volume is closed by all processes or stopped cleanly by the administrator, and all writes have been completed, VxVM removes the dirty flag for the volume. Only volumes that are marked dirty require resynchronization.

### Resynchronization process

The process of resynchronization depends on the type of volume. For mirrored volumes, resynchronization is done by placing the volume in recovery mode (also called read-writeback recovery mode). Resynchronization of data in the volume is done in the background. This allows the volume to be available for use while recovery is taking place. RAID-5 volumes that contain RAID-5 logs can “replay” those logs. If no logs are available, the volume is placed in reconstruct-recovery mode and all parity is regenerated.

Resynchronization can impact system performance. The recovery process reduces some of this impact by spreading the recoveries to avoid stressing a specific disk or controller.

For large volumes or for a large number of volumes, the resynchronization process can take time. These effects can be minimized by using dirty region logging (DRL) and FastResync (fast mirror resynchronization) for mirrored volumes, or by using RAID-5 logs for RAID-5 volumes.

See “[Dirty region logging](#)” on page 59.

See “[FastResync](#)” on page 64.

For mirrored volumes used by Oracle, you can use the SmartSync feature, which further improves performance.

See “[SmartSync recovery accelerator](#)” on page 60.

## Dirty region logging

Dirty region logging (DRL), if enabled, speeds recovery of mirrored volumes after a system crash. DRL tracks the regions that have changed due to I/O writes to a mirrored volume. DRL uses this information to recover only those portions of the volume.

If DRL is not used and a system failure occurs, all mirrors of the volumes must be restored to a consistent state. Restoration is done by copying the full contents of the volume between its mirrors. This process can be lengthy and I/O intensive.

---

**Note:** DRL adds a small I/O overhead for most write access patterns. This overhead is reduced by using SmartSync.

---

If a version 20 DCO volume is associated with a volume, a portion of the DCO volume can be used to store the DRL log. There is no need to create a separate DRL log for a volume which has a version 20 DCO volume.

See “[DCO volume versioning](#)” on page 67.

## Log subdisks and plexes

DRL log subdisks store the dirty region log of a mirrored volume that has DRL enabled. A volume with DRL has at least one log subdisk; multiple log subdisks can be used to mirror the dirty region log. Each log subdisk is associated with one plex of the volume. Only one log subdisk can exist per plex. If the plex contains only a log subdisk and no data subdisks, that plex is referred to as a log plex.

The log subdisk can also be associated with a regular plex that contains data subdisks. In that case, the log subdisk risks becoming unavailable if the plex must be detached due to the failure of one of its data subdisks.

If the `vxassist` command is used to create a dirty region log, it creates a log plex containing a single log subdisk by default. A dirty region log can also be set up manually by creating a log subdisk and associating it with a plex. The plex then contains both a log and data subdisks.

## Sequential DRL

Some volumes, such as those that are used for database replay logs, are written sequentially and do not benefit from delayed cleaning of the DRL bits. For these volumes, sequential DRL can be used to limit the number of dirty regions. This allows for faster recovery. However, if applied to volumes that are written to randomly, sequential DRL can be a performance bottleneck as it limits the number of parallel writes that can be carried out.

The maximum number of dirty regions allowed for sequential DRL is controlled by a tunable as detailed in the description of `voldr1_max_seq_dirty..`

See [“DMP tunable parameters”](#) on page 566.

See [“Adding traditional DRL logging to a mirrored volume”](#) on page 366.

See [“Preparing a volume for DRL and instant snapshots”](#) on page 360.

## SmartSync recovery accelerator

The SmartSync feature of Veritas Volume Manager increases the availability of mirrored volumes by only resynchronizing changed data. (The process of resynchronizing mirrored databases is also sometimes referred to as resilvering.) SmartSync reduces the time required to restore consistency, freeing more I/O bandwidth for business-critical applications. SmartSync uses an extended interface between VxVM volumes, VxFS file systems, and the Oracle database to avoid unnecessary work during mirror resynchronization and to reduce the I/O overhead of the DRL. For example, Oracle® automatically takes advantage of SmartSync to perform database resynchronization when it is available.

---

**Note:** To use SmartSync with volumes that contain file systems, see the discussion of the Oracle Resilvering feature of Veritas File System (VxFS).

---

The following section describes how to configure VxVM raw volumes and SmartSync. The database uses the following types of volumes:

- Data volumes are the volumes used by the database (control files and tablespace files).
- Redo log volumes contain redo logs of the database.

SmartSync works with these two types of volumes differently, so they must be configured as described in the following sections.

To enable the use of SmartSync with database volumes in shared disk groups, set the value of the `volcvm_smartsync` tunable to 1.

See [“Tunable parameters for VxVM”](#) on page 556.

## Data volume configuration

The recovery takes place when the database software is started, not at system startup. This reduces the overall impact of recovery when the system reboots. Because the recovery is controlled by the database, the recovery time for the volume is the resilvering time for the database (that is, the time required to replay the redo logs).

Because the database keeps its own logs, it is not necessary for VxVM to do logging. Data volumes should be configured as mirrored volumes without dirty region logs. In addition to improving recovery time, this avoids any run-time I/O overhead due to DRL, and improves normal database write access.

## Redo log volume configuration

A redo log is a log of changes to the database data. Because the database does not maintain changes to the redo logs, it cannot provide information about which sections require resilvering. Redo logs are also written sequentially, and since traditional dirty region logs are most useful with randomly-written data, they are of minimal use for reducing recovery time for redo logs. However, VxVM can reduce the number of dirty regions by modifying the behavior of its dirty region logging feature to take advantage of sequential access patterns. Sequential DRL decreases the amount of data needing recovery and reduces recovery time impact on the system.

The enhanced interfaces for redo logs allow the database software to inform VxVM when a volume is to be used as a redo log. This allows VxVM to modify the DRL behavior of the volume to take advantage of the access patterns. Since the improved recovery time depends on dirty region logs, redo log volumes should be configured as mirrored volumes with sequential DRL.

See [“Sequential DRL”](#) on page 60.

# Volume snapshots

Veritas Volume Manager provides the capability for taking an image of a volume at a given point in time. Such an image is referred to as a volume snapshot. Such snapshots should not be confused with file system snapshots, which are point-in-time images of a Veritas File System.

Figure 1-32 shows how a snapshot volume represents a copy of an original volume at a given point in time.

Figure 1-32 Volume snapshot as a point-in-time image of a volume

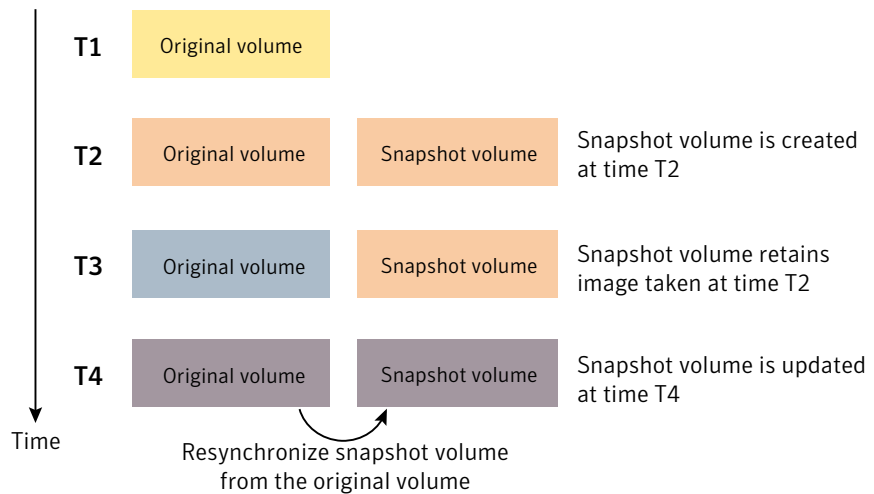

Even though the contents of the original volume can change, the snapshot volume preserves the contents of the original volume as they existed at an earlier time.

The snapshot volume provides a stable and independent base for making backups of the contents of the original volume, or for other applications such as decision support. In the figure, the contents of the snapshot volume are eventually resynchronized with the original volume at a later point in time.

Another possibility is to use the snapshot volume to restore the contents of the original volume. This may be useful if the contents of the original volume have become corrupted in some way.

---

**Warning:** If you write to the snapshot volume, it may no longer be suitable for use in restoring the contents of the original volume.

---

One type of volume snapshot in VxVM is the third-mirror break-off type. This name comes from its implementation where a snapshot plex (or third mirror) is added to a mirrored volume. The contents of the snapshot plex are then synchronized from the original plexes of the volume. When this synchronization is complete, the snapshot plex can be detached as a snapshot volume for use in backup or decision support applications. At a later time, the snapshot plex can be reattached to the original volume, requiring a full resynchronization of the snapshot plex's contents.

See [“Traditional third-mirror break-off snapshots”](#) on page 389.

The FastResync feature was introduced to track writes to the original volume. This tracking means that only a partial, and therefore much faster, resynchronization is required on reattaching the snapshot plex. In later releases, the snapshot model was enhanced to allow snapshot volumes to contain more than a single plex, reattachment of a subset of a snapshot volume's plexes, and persistence of FastResync across system reboots or cluster restarts.

See [“FastResync”](#) on page 64.

Release 4.0 of VxVM introduced full-sized instant snapshots and space-optimized instant snapshots, which offer advantages over traditional third-mirror snapshots such as immediate availability and easier configuration and administration. You can also use the third-mirror break-off usage model with full-sized snapshots, where this is necessary for write-intensive applications.

See [“Full-sized instant snapshots”](#) on page 390.

See [“Space-optimized instant snapshots”](#) on page 392.

See [“Emulation of third-mirror break-off snapshots”](#) on page 393.

See [“Linked break-off snapshot volumes”](#) on page 393.

See [“Comparison of snapshot features”](#) on page 63.

See [“About volume snapshots”](#) on page 387.

See the `vxassist(1M)` manual page.

See the `vxsnap(1M)` manual page.

## Comparison of snapshot features

[Table 1-1](#) compares the features of the various types of snapshots that are supported in VxVM.

**Table 1-1** Comparison of snapshot features for supported snapshot types

Snapshot feature	Full-sized instant (vxsnap)	Space-optimized instant (vxsnap)	Break-off (vxassist or vxsnap)
Immediately available for use on creation	Yes	Yes	No
Requires less storage space than original volume	No	Yes	No
Can be reattached to original volume	Yes	No	Yes
Can be used to restore contents of original volume	Yes	Yes	Yes
Can quickly be refreshed without being reattached	Yes	Yes	No
Snapshot hierarchy can be split	Yes	No	No
Can be moved into separate disk group from original volume	Yes	No	Yes
Can be turned into an independent volume	Yes	No	Yes
FastResync ability persists across system reboots or cluster restarts	Yes	Yes	Yes
Synchronization can be controlled	Yes	No	No
Can be moved off-host	Yes	No	Yes

Full-sized instant snapshots are easier to configure and offer more flexibility of use than do traditional third-mirror break-off snapshots. For preference, new volumes should be configured to use snapshots that have been created using the `vxsnap` command rather than using the `vxassist` command. Legacy volumes can also be reconfigured to use `vxsnap` snapshots, but this requires rewriting of administration scripts that assume the `vxassist` snapshot model.

## FastResync

---

**Note:** Only certain Storage Foundation products have a license to use this feature.

---



The FastResync feature (previously called Fast Mirror Resynchronization or FMR) performs quick and efficient resynchronization of stale mirrors (a mirror that is not synchronized). This increases the efficiency of the VxVM snapshot mechanism, and improves the performance of operations such as backup and decision support applications. Typically, these operations require that the volume is quiescent, and that they are not impeded by updates to the volume by other activities on the system. To achieve these goals, the snapshot mechanism in VxVM creates an exact copy of a primary volume at an instant in time. After a snapshot is taken, it can be accessed independently of the volume from which it was taken. In a Cluster Volume Manager (CVM) environment with shared access to storage, it is possible to eliminate the resource contention and performance overhead of using a snapshot simply by accessing it from a different node.

See [“Enabling FastResync on a volume”](#) on page 374.

## FastResync enhancements

FastResync provides the following enhancements to VxVM:

### Faster mirror resynchronization

FastResync optimizes mirror resynchronization by keeping track of updates to stored data that have been missed by a mirror. (A mirror may be unavailable because it has been detached from its volume, either automatically by VxVM as the result of an error, or directly by an administrator using a utility such as `vxplex` or `vxassist`. A returning mirror is a mirror that was previously detached and is in the process of being re-attached to its original volume as the result of the `vxrecover` or `vxplex att` operation.) When a mirror returns to service, only the updates that it has missed need to be re-applied to resynchronize it. This requires much less effort than the traditional method of copying all the stored data to the returning mirror.

Once FastResync has been enabled on a volume, it does not alter how you administer mirrors. The only visible effect is that repair operations conclude more quickly.

### Re-use of snapshots

FastResync allows you to refresh and re-use snapshots rather than discard them. You can quickly re-associate (snap back) snapshot plexes with their original volumes. This reduces the system overhead required to perform cyclical operations such as backups that rely on the volume snapshots.

## Non-persistent FastResync

Non-persistent FastResync allocates its change maps in memory. They do not reside on disk nor in persistent store. This has the advantage that updates to the FastResync map have little impact on I/O performance, as no disk updates needed to be performed. However, if a system is rebooted, the information in the map is lost, so a full resynchronization is required on snapback. This limitation can be overcome for volumes in cluster-shareable disk groups, provided that at least one of the nodes in the cluster remained running to preserve the FastResync map in its memory. However, a node crash in a High Availability (HA) environment requires the full resynchronization of a mirror when it is reattached to its parent volume.

### How non-persistent FastResync works with snapshots

The snapshot feature of VxVM takes advantage of FastResync change tracking to record updates to the original volume after a snapshot plex is created. After a snapshot is taken, the `snapback` option is used to reattach the snapshot plex. Provided that FastResync is enabled on a volume before the snapshot is taken, and that it is not disabled at any time before the snapshot is reattached, the changes that FastResync records are used to resynchronize the volume during the snapback. This considerably reduces the time needed to resynchronize the volume.

Non-Persistent FastResync uses a map in memory to implement change tracking. Each bit in the map represents a contiguous number of blocks in a volume's address space. The default size of the map is 4 blocks. The kernel tunable `vol_fmr_logsz` can be used to limit the maximum size in blocks of the map

See [“Tunable parameters for VxVM”](#) on page 556.

## Persistent FastResync

Unlike non-persistent FastResync, persistent FastResync keeps the FastResync maps on disk so that they can survive system reboots, system crashes and cluster crashes. Persistent FastResync can also track the association between volumes and their snapshot volumes after they are moved into different disk groups. When the disk groups are rejoined, this allows the snapshot plexes to be quickly resynchronized. This ability is not supported by non-persistent FastResync.

See [“Reorganizing the contents of disk groups”](#) on page 256.

If persistent FastResync is enabled on a volume or on a snapshot volume, a data change object (DCO) and a DCO volume are associated with the volume.

## DCO volume versioning

The internal layout of the DCO volume changed in VxVM 4.0 to support new features such as full-sized and space-optimized instant snapshots, and a unified DRL/DCO. Because the DCO volume layout is versioned, VxVM software continues to support the version 0 layout for legacy volumes. However, you must configure a volume to have a version 20 DCO volume if you want to take instant snapshots of the volume. Future releases of Veritas Volume Manager may introduce new versions of the DCO volume layout.

See [“Determining the DCO version number”](#) on page 363.

### Version 0 DCO volume layout

In earlier releases of VxVM, the DCO object only managed information about the FastResync maps. These maps track writes to the original volume and to each of up to 32 snapshot volumes since the last `snapshot` operation. Each plex of the DCO volume on disk holds 33 maps, each of which is 4 blocks in size by default.

Persistent FastResync uses the maps in a version 0 DCO volume on disk to implement change tracking. As for non-persistent FastResync, each bit in the map represents a region (a contiguous number of blocks) in a volume’s address space. The size of each map can be changed by specifying the `dcoLen` attribute to the `vxassist` command when the volume is created. The default value of `dcoLen` is 132 512-byte blocks (the plex contains 33 maps, each of length 4 blocks). To use a larger map size, multiply the desired map size by 33 to calculate the value of `dcoLen` that you need to specify. For example, to use an 8-block map, you would specify `dcoLen=264`. The maximum possible map size is 64 blocks, which corresponds to a `dcoLen` value of 2112 blocks.

The size of a DCO plex is rounded up to the nearest integer multiple of the disk group alignment value. The alignment value is 8KB for disk groups that support the Cross-platform Data Sharing (CDS) feature. Otherwise, the alignment value is 1 block.

Only traditional (third-mirror) volume snapshots that are administered using the `vxassist` command are supported for the version 0 DCO volume layout. Full-sized and space-optimized instant snapshots are not supported.

### Version 20 DCO volume layout

In VxVM 4.0 and later releases, the DCO object is used not only to manage the FastResync maps, but also to manage DRL recovery maps and special maps called copymaps that allow instant snapshot operations to resume correctly following a system crash.

See “[Dirty region logging](#)” on page 59.

Each bit in a map represents a region (a contiguous number of blocks) in a volume’s address space. A region represents the smallest portion of a volume for which changes are recorded in a map. A write to a single byte of storage anywhere within a region is treated in the same way as a write to the entire region.

The layout of a version 20 DCO volume includes an accumulator that stores the DRL map and a per-region state map for the volume, plus 32 per-volume maps (by default) including a DRL recovery map, and a map for tracking detaches that are initiated by the kernel due to I/O error. The remaining 30 per-volume maps (by default) are used either for tracking writes to snapshots, or as copymaps. The size of the DCO volume is determined by the size of the regions that are tracked, and by the number of per-volume maps. Both the region size and the number of per-volume maps in a DCO volume may be configured when a volume is prepared for use with snapshots. The region size must be a power of 2 and be greater than or equal to 16KB.

As the accumulator is approximately 3 times the size of a per-volume map, the size of each plex in the DCO volume can be estimated from this formula:

$$DCO\_plex\_size = ( 3 + number\_of\_per\_volume\_maps ) * map\_size$$

where the size of each map in bytes is:

$$map\_size = 512 + ( volume\_size / ( region\_size * 8 ) )$$

rounded up to the nearest multiple of 8KB. Note that each map includes a 512-byte header.

For the default number of 32 per-volume maps and region size of 64KB, a 10GB volume requires a map size of 24KB, and so each plex in the DCO volume requires 840KB of storage.

---

**Note:** Full-sized and space-optimized instant snapshots, which are administered using the `vxsnap` command, are supported for a version 20 DCO volume layout. The use of the `vxassist` command to administer traditional (third-mirror break-off) snapshots is not supported for a version 20 DCO volume layout.

---

## How persistent FastResync works with snapshots

Persistent FastResync uses a map in a DCO volume on disk to implement change tracking. As for non-persistent FastResync, each bit in the map represents a contiguous number of blocks in a volume’s address space.

[Figure 1-33](#) shows an example of a mirrored volume with two plexes on which Persistent FastResync is enabled.

**Figure 1-33** Mirrored volume with persistent FastResync enabled

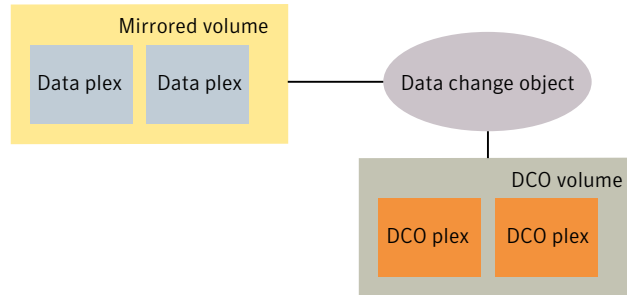

Associated with the volume are a DCO object and a DCO volume with two plexes. To create a traditional third-mirror snapshot or an instant (copy-on-write) snapshot, the `vxassist snapstart` or `vxsnap make` operation respectively is performed on the volume.

[Figure 1-34](#) shows how a snapshot plex is set up in the volume, and how a disabled DCO plex is associated with it.

**Figure 1-34** Mirrored volume after completion of a snapstart operation

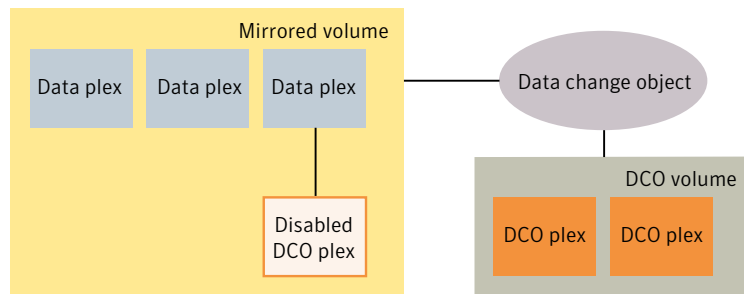

Multiple snapshot plexes and associated DCO plexes may be created in the volume by re-running the `vxassist snapstart` command for traditional snapshots, or the `vxsnap make` command for space-optimized snapshots. You can create up to a total of 32 plexes (data and log) in a volume.

Space-optimized instant snapshots do not require additional full-sized plexes to be created. Instead, they use a storage cache that typically requires only 10% of the storage that is required by full-sized snapshots. There is a trade-off in functionality in using space-optimized snapshots. The storage cache is formed within a cache volume, and this volume is associated with a cache object. For convenience of operation, this cache can be shared by all the space-optimized instant snapshots within a disk group.

See “[Comparison of snapshot features](#)” on page 63.

A traditional snapshot volume is created from a snapshot plex by running the `vxassist snapshot` operation on the volume. For instant snapshots, however, the `vxsnap make` command makes an instant snapshot volume immediately available for use. There is no need to run an additional command.

[Figure 1-35](#) shows how the creation of the snapshot volume also sets up a DCO object and a DCO volume for the snapshot volume.

**Figure 1-35** Mirrored volume and snapshot volume after completion of a snapshot operation

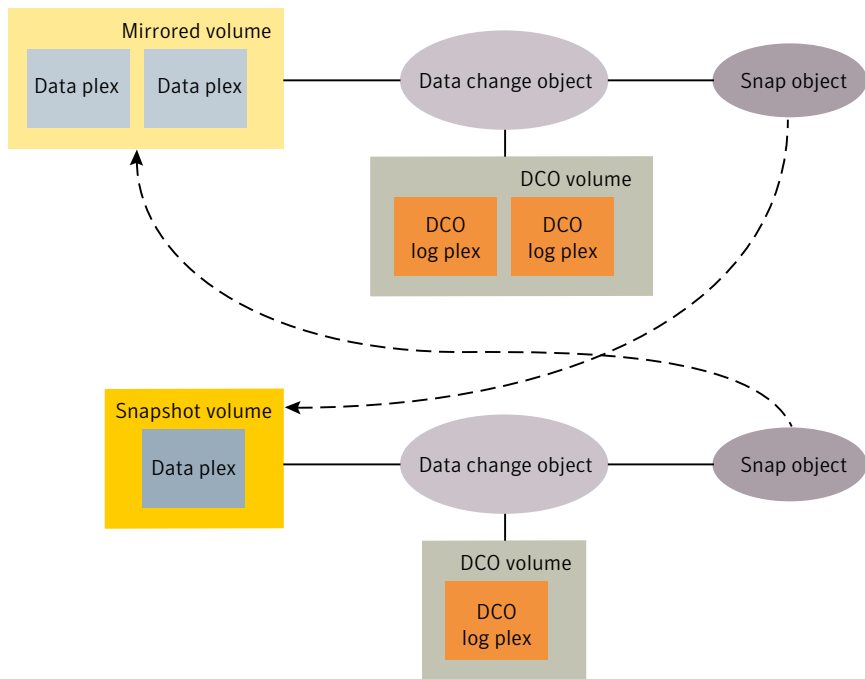

The DCO volume contains the single DCO plex that was associated with the snapshot plex. If two snapshot plexes were taken to form the snapshot volume, the DCO volume would contain two plexes. For space-optimized instant snapshots, the DCO object and DCO volume are associated with a snapshot volume that is created on a cache object and not on a VM disk.

Associated with both the original volume and the snapshot volume are snap objects. The snap object for the original volume points to the snapshot volume, and the snap object for the snapshot volume points to the original volume. This

allows VxVM to track the relationship between volumes and their snapshots even if they are moved into different disk groups.

The snap objects in the original volume and snapshot volume are automatically deleted in the following circumstances:

- For traditional snapshots, the `vxassist snapback` operation is run to return all of the plexes of the snapshot volume to the original volume.
- For traditional snapshots, the `vxassist snapclear` operation is run on a volume to break the association between the original volume and the snapshot volume. If the volumes are in different disk groups, the command must be run separately on each volume.
- For full-sized instant snapshots, the `vxsnap reattach` operation is run to return all of the plexes of the snapshot volume to the original volume.
- For full-sized instant snapshots, the `vxsnap dis` or `vxsnap split` operations are run on a volume to break the association between the original volume and the snapshot volume. If the volumes are in different disk groups, the command must be run separately on each volume.

---

**Note:** The `vxsnap reattach`, `dis` and `split` operations are not supported for space-optimized instant snapshots.

---

See “[Space-optimized instant snapshots](#)” on page 392.

See the `vxassist(1M)` manual page.

See the `vxsnap(1M)` manual page.

## Effect of growing a volume on the FastResync map

It is possible to grow the replica volume, or the original volume, and still use FastResync. According to the DCO volume layout, growing the volume has the following different effects on the map that FastResync uses to track changes to the original volume:

- For a version 20 DCO volume, the size of the map is increased and the size of the region that is tracked by each bit in the map stays the same.
- For a version 0 DCO volume, the size of the map remains the same and the region size is increased.

In either case, the part of the map that corresponds to the grown area of the volume is marked as “dirty” so that this area is resynchronized. The `snapback` operation fails if it attempts to create an incomplete snapshot plex. In such cases, you must grow the replica volume, or the original volume, before invoking any of

the commands `vxsnap reattach`, `vxsnap restore`, or `vxassist snapback`.

Growing the two volumes separately can lead to a snapshot that shares physical disks with another mirror in the volume. To prevent this, grow the volume after the `snapback` command is complete.

## FastResync limitations

The following limitations apply to FastResync:

- Persistent FastResync is supported for RAID-5 volumes, but this prevents the use of the relayout or resize operations on the volume while a DCO is associated with it.
- Neither non-persistent nor persistent FastResync can be used to resynchronize mirrors after a system crash. Dirty region logging (DRL), which can coexist with FastResync, should be used for this purpose. In VxVM 4.0 and later releases, DRL logs may be stored in a version 20 DCO volume.
- When a subdisk is relocated, the entire plex is marked “dirty” and a full resynchronization becomes necessary.
- If a snapshot volume is split off into another disk group, non-persistent FastResync cannot be used to resynchronize the snapshot plexes with the original volume when the disk group is rejoined with the original volume’s disk group. Persistent FastResync must be used for this purpose.
- If you move or split an original volume (on which persistent FastResync is enabled) into another disk group, and then move or join it to a snapshot volume’s disk group, you cannot use `vxassist snapback` to resynchronize traditional snapshot plexes with the original volume. This restriction arises because a snapshot volume references the original volume by its record ID at the time that the snapshot volume was created. Moving the original volume to a different disk group changes the volume’s record ID, and so breaks the association. However, in such a case, you can use the `vxplex snapback` command with the `-f` (force) option to perform the `snapback`.

---

**Note:** This restriction only applies to traditional snapshots. It does not apply to instant snapshots.

---

- Any operation that changes the layout of a replica volume can mark the FastResync change map for that snapshot “dirty” and require a full resynchronization during `snapback`. Operations that cause this include subdisk split, subdisk move, and online relayout of the replica. It is safe to perform these operations after the snapshot is completed.



See the `vxassist` (1M) manual page.

See the `vxplex` (1M) manual page.

See the `vxvol` (1M) manual page.

## Hot-relocation

Hot-relocation is a feature that allows a system to react automatically to I/O failures on redundant objects (mirrored or RAID-5 volumes) in VxVM and restore redundancy and access to those objects. VxVM detects I/O failures on objects and relocates the affected subdisks. The subdisks are relocated to disks designated as spare disks or to free space within the disk group. VxVM then reconstructs the objects that existed before the failure and makes them accessible again.

When a partial disk failure occurs (that is, a failure affecting only some subdisks on a disk), redundant data on the failed portion of the disk is relocated. Existing volumes on the unaffected portions of the disk remain accessible.

See [“How hot-relocation works”](#) on page 468.

## Volume sets

Volume sets are an enhancement to VxVM that allow several volumes to be represented by a single logical object. All I/O from and to the underlying volumes is directed via the I/O interfaces of the volume set. The Veritas File System (VxFS) uses volume sets to manage multi-volume file systems and Dynamic Storage Tiering. This feature allows VxFS to make best use of the different performance and availability characteristics of the underlying volumes. For example, file system metadata can be stored on volumes with higher redundancy, and user data on volumes with better performance.

See [“Creating a volume set”](#) on page 448.

## Configuration of volumes on SAN storage

Storage Area Networks (SANs) provide a networking paradigm that provides easily reconfigurable connectivity between any subset of computers, disk storage and interconnecting hardware such as switches, hubs and bridges. A SAN can contain a huge number of devices connected using either arbitrated or switched fabric. A SAN that has thousands or tens of thousands of connected devices is difficult to administer using a simple disk group model. Veritas CommandCentral Storage software allows you to configure storage groups and storage accounts. Using the CommandCentral Storage software, you can allocate SAN storage more prudently and administer your complex SAN environments more effectively.

---

**Note:** This feature of `vxassist` is designed to work in conjunction with SAL (SAN Access Layer) in Veritas CommandCentral Storage. When VxVM with SAN-aware `vxassist` is installed on a host where SAL is also installed, it is recommended that you create a user named `root` under SAL. This allows `vxassist` to use the `root` login to contact the SAL daemon (`sald`) on the primary SAL server without needing to specify the `sal_username` attribute to `vxassist`.

---

Figure 1-36, shows how you might choose to set up storage groups within a SAN.

**Figure 1-36** Dividing a Storage Area Network into storage groups

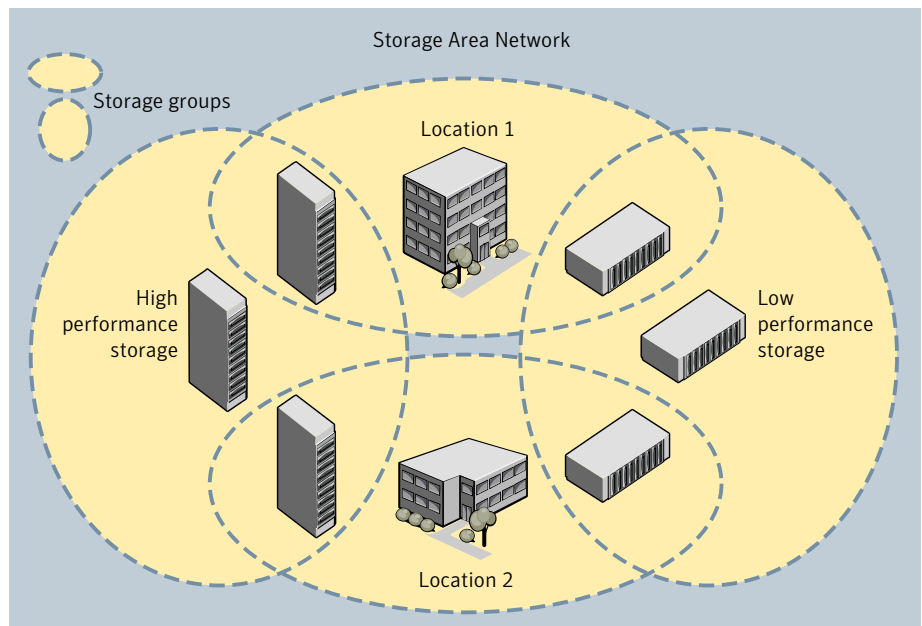

In this example, the boundaries of the storage groups are based on the performance characteristics of different makes of disk array and on geographic location.

The `vxassist` utility in Veritas Volume Manager understands storage groups that you have defined using the CommandCentral Storage software. `vxassist` supports a simple language that you can use to specify how disks are to be allocated from pre-defined storage groups. This specification language defines the confinement and separation criteria that `vxassist` applies to the available storage to choose disks for creating, resizing or moving a volume.

To use the CommandCentral Storage storage groups with `vxassist`, perform the following steps in the order listed:

- Use the CommandCentral Storage software to define one or more storage groups. Note that zoning is not an issue as it is completely independent of storage group creation.
- Use the CommandCentral Storage software to attach attribute-value pairs to each storage group's property sheet. Typically, you would assign values for the following attributes: location, storage group, and protection.
- Use the `vxspcshow` command to discover the device names of disks that have a specified set of attributes, or to list the attributes of specified disks.
- Use the `vxdiskadm` command or the VEA to configure the disks that you found in the previous step into VxVM disk groups.
- Use `vxassist` to create volumes on disks that are selected by matching specified criteria for the values of storage group attributes. The usual restriction applies that a volume may only be created using disks from a single disk group.



# Provisioning new usable storage

This chapter includes the following topics:

- [Provisioning new usable storage](#)
- [Growing existing storage by adding a new LUN](#)
- [Growing existing storage by growing the LUN](#)

## Provisioning new usable storage

The following procedure describes how to provision new usable storage.

To provision new usable storage

- 1 Set up the LUN. See the documentation for your storage array for how to create, mask, and bind the LUN.

- 2 Initialize the LUNs for use by Veritas Volume Manager (VxVM):

```
# vxdisksetup -i 3PARDATA0_1
# vxdisk init 3PARDATA0_1
```

- 3 Add the LUN to a diskgroup.

- If you do not have a diskgroup for your LUN, create the diskgroup:

```
# vxdg init dg1 3PARDATA0_1=dev1
```

- If you already have a diskgroup for your LUN, add the LUN to the diskgroup:

```
# vxdg -g dg1 adddisk 3PARDATA0_1
```

- 4 Create the volume on the LUN:

```
# vxassist -b -g dg1 make vol1 100g 3PARDATA0_1
```

- 5 Create a file system on the volume:

```
# mkfs -F vxfs /dev/vx/rdisk/dg1/vol1
```

- 6 Create a mount point on the file system:

```
# mkdir mount1
```

- 7 Mount the file system:

```
# mount -F vxfs /dev/vx/rdisk/dg1/vol1 /mount1
```

## Growing existing storage by adding a new LUN

The following procedure describes how to grow existing storage by adding a new LUN.

To grow existing storage by adding a new LUN

- 1 Create and set up the LUN.

- 2 Add the LUN to the diskgroup:

```
# vxdg -g dg1 adddisk 3PARDATA0_2
```

- 3 Grow the volume and file system to the desired size:

```
# vxresize -b -F vxfs -g dg1 vol1 100g
```

## Growing existing storage by growing the LUN

The following procedure describes how to grow existing storage by growing a LUN.

**To grow existing storage by growing a LUN**

- 1 Grow the existing LUN. See the documentation for your storage array for how to create, mask, and bind the LUN.
- 2 Make VxVM aware of the new LUN size.

```
# vxdisk -g dg1 resize c0t1d0s4
```

See the *Veritas Volume Manager Administrator's Guide* for information about dynamic LUN expansion.

- 3 Calculate the new maximum volume size:

```
# vxassist -b maxgrow vol1
```

- 4 Grow the volume and file system to the desired size:

```
# vxresize -b -F vxfs -g dg1 vol1 150g
```





# Administering disks

This chapter includes the following topics:

- [About disk management](#)
- [Disk devices](#)
- [Discovering and configuring newly added disk devices](#)
- [Disks under VxVM control](#)
- [VxVM coexistence with SVM and ZFS](#)
- [Changing the disk-naming scheme](#)
- [Discovering the association between enclosure-based disk names and OS-based disk names](#)
- [Disk installation and formatting](#)
- [Displaying or changing default disk layout attributes](#)
- [Adding a disk to VxVM](#)
- [RAM disk support in VxVM](#)
- [Encapsulating a disk](#)
- [Rootability](#)
- [Unencapsulating the root disk](#)
- [Displaying disk information](#)
- [Dynamic LUN expansion](#)
- [Removing disks](#)
- [Removing a disk from VxVM control](#)

- [Removing and replacing disks](#)
- [Enabling a disk](#)
- [Taking a disk offline](#)
- [Renaming a disk](#)
- [Reserving disks](#)
- [Changing host LUN configurations online](#)

## About disk management

Veritas Volume Manager (VxVM) allows you to place disks under VxVM control, to initialize or encapsulate disks, and to remove and replace disks.

---

**Note:** Most VxVM commands require superuser or equivalent privileges.

---

Disks that are controlled by the Sun Microsystems Solaris Volume Manager software cannot be used directly as VxVM disks, but the disks can be converted so that their volumes become VxVM volumes.

The dynamic multipathing (DMP) feature of VxVM is used to administer multiported disk arrays.

See [“How DMP works”](#) on page 165.

## Disk devices

When performing disk administration, it is important to understand the difference between a disk name and a device name.

The disk name (also known as a disk media name) is the symbolic name assigned to a VM disk. When you place a disk under VxVM control, a VM disk is assigned to it. The disk name is used to refer to the VM disk for the purposes of administration. A disk name can be up to 31 characters long. When you add a disk to a disk group, you can assign a disk name or allow VxVM to assign a disk name. The default disk name is *diskgroup##* where *diskgroup* is the name of the disk group to which the disk is being added, and *##* is a sequence number. Your system may use device names that differ from those given in the examples.

The device name (sometimes referred to as devname or disk access name) defines the name of a disk device as it is known to the operating system.

Such devices are usually, but not always, located in the `/dev/dsk` and `/dev/rdisk` directories. Devices that are specific to hardware from certain vendors may use their own path name conventions.

VxVM uses the device names to create metadevices in the `/dev/vx/[r]dmp` directories. The Dynamic Multipathing (DMP) feature of VxVM uses these metadevices (or DMP nodes) to represent disks that can be accessed by one or more physical paths, perhaps via different controllers. The number of access paths that are available depends on whether the disk is a single disk, or is part of a multiported disk array that is connected to a system.

You can use the `vxdisk` utility to display the paths that are subsumed by a DMP metadevice, and to display the status of each path (for example, whether it is enabled or disabled).

See [“How DMP works”](#) on page 165.

Device names may also be remapped as enclosure-based names.

See [“Disk device naming in VxVM”](#) on page 83.

## Disk device naming in VxVM

Device names for disks are assigned according to the naming scheme which you specify to VxVM. The format of the device name may vary for different categories of disks.

See [“Disk categories”](#) on page 90.

Device names can use one of the following naming schemes:

- [Operating system-based naming](#)
- [Enclosure-based naming](#)

Devices with device names longer than 31 characters always use enclosure-based names.

You can change the disk-naming scheme if required.

See [“Changing the disk-naming scheme”](#) on page 107.

### Operating system-based naming

In the OS-based naming scheme, all disk devices except fabric mode disks are named using the `c#t#d#s#` format.

The syntax of a device name is `c#t#d#s#`, where `c#` represents a controller on a host bus adapter, `t#` is the target controller ID, `d#` identifies a disk on the target controller, and `s#` represents a partition (or slice) on the disk.

---

**Note:** For non-EFI disks, the slice `s2` represents the entire disk. For both EFI and non-EFI disks, the entire disk is implied if the slice is omitted from the device name.

---

The boot disk (which contains the root file system and is used when booting the system) is often identified to VxVM by the device name `c0t0d0`.

Fabric mode disk devices are named as follows:

- Disks in supported disk arrays are named using the `enclosure_name_#` format. For example, disks in the supported disk array name `FirstFloor` are named `FirstFloor_0`, `FirstFloor_1`, `FirstFloor_2` and so on. You can use the `vxddmpadm` command to administer enclosure names.
- Disks in the `DISKS` category (JBOD disks) are named using the `Disk_#` format.
- Disks in the `OTHER_DISKS` category (disks that are not multipathed by DMP) are named using the `fabric_#` format.

OS-based names can be made persistent, so that they do not change after reboot. By default, OS-based names are not persistent, and are regenerated if the system configuration changes the device name as recognized by the operating system.

## Enclosure-based naming

Enclosure-based naming operates as follows:

- All fabric or non-fabric disks in supported disk arrays are named using the `enclosure_name_#` format. For example, disks in the supported disk array, `enggdept` are named `enggdept_0`, `enggdept_1`, `enggdept_2` and so on. You can use the `vxddmpadm` command to administer enclosure names. See [“Renaming an enclosure”](#) on page 209. See the `vxddmpadm(1M)` manual page.
- Disks in the `DISKS` category (JBOD disks) are named using the `Disk_#` format.
- Disks in the `OTHER_DISKS` category (disks that are not multipathed by DMP) are named as follows:
  - Non-fabric disks are named using the `c#t#d#s#` format.
  - Fabric disks are named using the `fabric_#` format.

By default, enclosure-based names are persistent, so they do not change after reboot.

If a CVM cluster is symmetric, each node in the cluster accesses the same set of disks. Enclosure-based names provide a consistent naming system so that the device names are the same on each node.

To display the native OS device names of a VM disk (such as `mydg01`), use the following command:

```
# vxdisk path | grep diskname
```

See [“Renaming an enclosure”](#) on page 209.

See [“Disk categories”](#) on page 90.

## Private and public disk regions

Most VM disks consist of the following regions:

private region	<p>A small area where configuration information is stored, including a disk header label, configuration records for VxVM objects, and an intent log for the configuration database.</p> <p>The default private region size is 32 megabytes, which is large enough to record the details of several thousand VxVM objects in a disk group.</p> <p>Under most circumstances, the default private region size should be sufficient. For administrative purposes, it is usually much simpler to create more disk groups that contain fewer volumes, or to split large disk groups into several smaller ones.</p> <p>See <a href="#">“Splitting disk groups”</a> on page 266.</p> <p>If required, the value for the private region size may be overridden when you add or replace a disk using the <code>vxdiskadm</code> command.</p> <p>Each disk that has a private region holds an entire copy of the configuration database for the disk group. The size of the configuration database for a disk group is limited by the size of the smallest copy of the configuration database on any of its member disks.</p>
public region	<p>An area that covers the remainder of the disk, and which is used for the allocation of storage space to subdisks.</p>

A disk’s type identifies how VxVM accesses a disk, and how it manages the disk’s private and public regions.

The following disk access types are used by VxVM:

auto	<p>When the <code>vxconfigd</code> daemon is started, VxVM obtains a list of known disk device addresses from the operating system and configures disk access records for them automatically.</p>
------	---

<code>nopriv</code>	There is no private region (only a public region for allocating subdisks). This is the simplest disk type consisting only of space for allocating subdisks. Such disks are most useful for defining special devices (such as RAM disks, if supported) on which private region data would not persist between reboots. They can also be used to encapsulate disks where there is insufficient room for a private region. The disks cannot store configuration and log copies, and they do not support the use of the <code>vxdisk addregion</code> command to define reserved regions. VxVM cannot track the movement of <code>nopriv</code> disks on a SCSI chain or between controllers.
<code>simple</code>	The public and private regions are on the same disk area (with the public area following the private area).
<code>sliced</code>	The public and private regions are on different disk partitions.

Auto-configured disks (with disk access type `auto`) support the following disk formats:

<code>cdsdisk</code>	The disk is formatted as a Cross-platform Data Sharing (CDS) disk that is suitable for moving between different operating systems. This is the default format for disks that are not used to boot the system. Typically, most disks on a system are configured as this disk type. However, it is not a suitable format for boot, root or swap disks, for mirrors or hot-relocation spares of such disks, or for Extensible Firmware Interface (EFI) disks.
<code>simple</code>	The disk is formatted as a simple disk that can be converted to a CDS disk.
<code>sliced</code>	The disk is formatted as a sliced disk. This format can be applied to disks that are used to boot the system. The disk can be converted to a CDS disk if it was not initialized for use as a boot disk.

The `vxcdsconvert` utility can be used to convert disks to the `cdsdisk` format.

See the `vxcdsconvert(1M)` manual page.

---

**Warning:** The CDS disk format is incompatible with EFI disks. If a disk is initialized by VxVM as a CDS disk, the CDS header occupies the portion of the disk where the VTOC would usually be located. If you subsequently use a command such as `fdisk` or `format` to create a partition table on a CDS disk, this erases the CDS information and could cause data corruption.

---

By default, auto-configured non-EFI disks are formatted as `cdsdisk` disks when they are initialized for use with VxVM. You can change the default format by using the `vxdiskadm(1M)` command to update the `/etc/default/vxdisk` defaults file.

Auto-configured EFI disks are formatted as `sliced` disks by default.

VxVM initializes each new disk with the smallest possible number of partitions. For non-EFI disks of type `sliced`, VxVM usually configures partition `s3` as the private region, `s4` as the public region, and `s2` as the entire physical disk. An exception is an encapsulated root disk, on which `s3` is usually configured as the public region and `s4` as the private region.

See “[Displaying or changing default disk layout attributes](#)” on page 115.

See the `vxdisk(1M)` manual page.

## Discovering and configuring newly added disk devices

The `vxdiskconfig` utility scans and configures new disk devices attached to the host, disk devices that become online, or fibre channel devices that are zoned to host bus adapters connected to this host. The command calls platform specific interfaces to configure new disk devices and brings them under control of the operating system. It scans for disks that were added since VxVM’s configuration daemon was last started. These disks are then dynamically configured and recognized by VxVM.

`vxdiskconfig` should be used whenever disks are physically connected to the host or when fibre channel devices are zoned to the host.

`vxdiskconfig` calls `vxdtl enable` to rebuild volume device node directories and update the DMP internal database to reflect the new state of the system.

You can also use the `vxdisk scandisks` command to scan devices in the operating system device tree, and to initiate dynamic reconfiguration of multipathed disks.

If you want VxVM to scan only for new devices that have been added to the system, and not for devices that have been enabled or disabled, specify the `-f` option to either of the commands, as shown here:

```
# vxdtl -f enable
# vxdisk -f scandisks
```

However, a complete scan is initiated if the system configuration has been modified by changes to:

- Installed array support libraries.

- The list of devices that are excluded from use by VxVM.
- DISKS (JBOD), SCSI3, or foreign device definitions.

See the `vxdtl(1M)` manual page.

See the `vxdisk(1M)` manual page.

## Partial device discovery

The Dynamic Multipathing (DMP) feature of VxVM supports partial device discovery where you can include or exclude sets of disks or disks attached to controllers from the discovery process.

The `vxdisk scandisks` command rescans the devices in the OS device tree and triggers a DMP reconfiguration. You can specify parameters to `vxdisk scandisks` to implement partial device discovery. For example, this command makes VxVM discover newly added devices that were unknown to it earlier:

```
# vxdisk scandisks new
```

The next example discovers fabric devices:

```
# vxdisk scandisks fabric
```

The above command discovers devices with the characteristic `DDI_NT_FABRIC` property set on them.

The following command scans for the devices `c1t1d0` and `c2t2d0`:

```
# vxdisk scandisks device=c1t1d0,c2t2d0
```

Alternatively, you can specify a `!` prefix character to indicate that you want to scan for all devices except those that are listed.

---

**Note:** The `!` character is a special character in some shells. The following examples show how to escape it in a bash shell.

---

```
# vxdisk scandisks \!device=c1t1d0,c2t2d0
```

You can also scan for devices that are connected (or not connected) to a list of logical or physical controllers. For example, this command discovers and configures all devices except those that are connected to the specified logical controllers:

```
# vxdisk scandisks \!ctlr=c1,c2
```

The next command discovers devices that are connected to the specified physical controller:



```
# vxdisk scandisks pctlr=/pci@1f,4000/scsi@3/
```

The items in a list of physical controllers are separated by + characters.

You can use the command `vxmpadm getctlr all` to obtain a list of physical controllers.

You may specify only one selection argument to the `vxdisk scandisks` command. Specifying multiple options results in an error.

See the `vxdisk(1M)` manual page.

## Discovering disks and dynamically adding disk arrays

DMP uses array support libraries (ASLs) to provide array-specific support for multipathing. An array support library (ASL) is a dynamically loadable shared library (plug-in for DDL). The ASL implements hardware-specific logic to discover device attributes during device discovery. DMP provides the device discovery layer (DDL) to determine which ASLs should be associated to each disk array

In some cases, DMP can also provide basic multipathing and failover functionality by treating LUNs as disks (JBODs).

### How DMP claims devices

For fully optimized support of any array and for support of more complicated array types, DMP requires the use of array-specific array support libraries (ASLs), possibly coupled with array policy modules (APMs). ASLs and APMs effectively are array-specific plugins that allow close tie-in of DMP with any specific array model.

See the Hardware Compatibility List for the complete list of supported arrays.

<http://entsupport.symantec.com/docs/330441>

During device discovery, the DDL checks the installed ASL for each device to find which ASL claims the device. If no ASL is found to claim the device, the DDL checks for a corresponding JBOD definition. You can add JBOD definitions for unsupported arrays to enable DMP to provide multipathing for the array. If a JBOD definition is found, the DDL claims the devices in the DISKS category, which adds the LUNs to the list of JBOD (physical disk) devices used by DMP. If the JBOD definition includes a cabinet number, DDL uses the cabinet number to group the LUNs into enclosures.

See “[Adding unsupported disk arrays to the DISKS category](#)” on page 100.

DMP can provide basic multipathing to ALUA-compliant arrays even if there is no ASL or JBOD definition. DDL claims the LUNs as part of the `aludisk` enclosure.

The array type is shown as ALUA. Adding a JBOD definition also enables you to group the LUNs into enclosures.

## Disk categories

Disk arrays that have been certified for use with Veritas Volume Manager are supported by an array support library (ASL), and are categorized by the vendor ID string that is returned by the disks (for example, "HITACHI").

Disks in JBODs which are capable of being multipathed by DMP, are placed in the `DISKS` category. Disks in unsupported arrays can also be placed in the `DISKS` category.

See "[Adding unsupported disk arrays to the DISKS category](#)" on page 100.

Disks in JBODs that do not fall into any supported category, and which are not capable of being multipathed by DMP are placed in the `OTHER_DISKS` category.

## Adding support for a new disk array

You can dynamically add support for a new type of disk array which has been developed by Symantec. The support comes in the form of Array Support Libraries (ASLs). Symantec provides support for new disk arrays through updates to the `VRTSaslapm` package. To determine if an updated `VRTSaslapm` package is available for download, refer to the hardware compatibility list tech note. The hardware compatibility list provides a link to the latest package for download and instructions for installing the `VRTSaslapm` package. You can upgrade the `VRTSaslapm` package while the system is online; you do not need to stop the applications.

To access the hardware compatibility list, go to the following URL:

<http://entsupport.symantec.com/docs/330441>

The new disk array does not need to be already connected to the system when the package is installed. If any of the disks in the new disk array are subsequently connected, and if `vxconfigd` is running, `vxconfigd` immediately invokes the Device Discovery function and includes the new disks in the VxVM device list.

If you need to remove the latest `VRTSaslapm` package, you can revert to the previously installed version. For the detailed procedure, refer to the *Veritas Volume Manager Troubleshooting Guide*.

## Enabling discovery of new disk arrays

The `vxdtl enable` command scans all of the disk devices and their attributes, updates the VxVM device list, and reconfigures DMP with the new device database. There is no need to reboot the host.

---

**Warning:** This command ensures that dynamic multipathing is set up correctly on the array. Otherwise, VxVM treats the independent paths to the disks as separate devices, which can result in data corruption.

---

### To enable discovery of a new disk array

- ◆ Type the following command:

```
# vxdtl enable
```

## Third-party driver coexistence

The third-party driver (TPD) coexistence feature of VxVM allows I/O that is controlled by some third-party multipathing drivers to bypass DMP while retaining the monitoring capabilities of DMP. If a suitable ASL is available and installed, devices that use TPDs can be discovered without requiring you to set up a specification file, or to run a special command. In previous releases, VxVM only supported TPD coexistence if the code of the third-party driver was intrusively modified. The new TPD coexistence feature maintains backward compatibility with such methods, but it also permits coexistence without require any change in a third-party multipathing driver.

See [“Changing device naming for TPD-controlled enclosures”](#) on page 110.

See [“Displaying information about TPD-controlled devices”](#) on page 187.

## Autodiscovery of EMC Symmetrix arrays

In VxVM 4.0, there were two possible ways to configure EMC Symmetrix arrays:

- With EMC PowerPath installed, EMC Symmetrix arrays could be configured as foreign devices.  
See [“Foreign devices”](#) on page 104.
- Without EMC PowerPath installed, DMP could be used to perform multipathing.

On upgrading a system to VxVM 4.1 or later release, existing EMC PowerPath devices can be discovered by DDL, and configured into DMP as autoconfigured disks with DMP nodes, even if PowerPath is being used to perform multipathing. There is no need to configure such arrays as foreign devices.

**Table 3-1** shows the scenarios for using DMP with PowerPath.

The ASLs are all included in the ASL-APM package, which is installed when you install Storage Foundation products.

**Table 3-1** Scenarios for using DMP with PowerPath

PowerPath	DMP	Array configuration mode
Installed.	The <code>libvxpp</code> ASL handles EMC Symmetrix arrays and DGC CLARiiON claiming internally. PowerPath handles failover.	EMC Symmetrix - Any DGC CLARiiON - Active/Passive (A/P), Active/Passive in Explicit Failover mode (A/P-F) and ALUA Explicit failover
Not installed; the array is EMC Symmetrix.	DMP handles multipathing. The ASL name is <code>libvxemc</code> .	Active/Active
Not installed; the array is DGC CLARiiON (CXn00).	DMP handles multipathing. The ASL name is <code>libvxCLARiiON</code> .	Active/Passive (A/P), Active/Passive in Explicit Failover mode (A/P-F) and ALUA

If any EMCpower discs are configured as foreign discs, use the `vxddladm rmforeign` command to remove the foreign definitions, as shown in this example:

```
# vxddladm rmforeign blockpath=/dev/dsk/emcpower10 \
    charpath=/dev/rdisk/emcpower10
```

To allow DMP to receive correct inquiry data, the Common Serial Number (C-bit) Symmetrix Director parameter must be set to enabled.

## How to administer the Device Discovery Layer

The Device Discovery Layer (DDL) allows dynamic addition of disk arrays. DDL discovers disks and their attributes that are required for VxVM and DMP operations.

The DDL is administered using the `vxddladm` utility to perform the following tasks:

- List the hierarchy of all the devices discovered by DDL including iSCSI devices.
- List all the Host Bus Adapters including iSCSI
- List the ports configured on a Host Bus Adapter

- List the targets configured from a Host Bus Adapter
- List the devices configured from a Host Bus Adapter
- Get or set the iSCSI operational parameters
- List the types of arrays that are supported.
- Add support for an array to DDL.
- Remove support for an array from DDL.
- List information about excluded disk arrays.
- List disks that are supported in the `DISKS` (JBOD) category.
- Add disks from different vendors to the `DISKS` category.
- Remove disks from the `DISKS` category.
- Add disks as foreign devices.

The following sections explain these tasks in more detail.

See the `vxddladm(1M)` manual page.

## Listing all the devices including iSCSI

You can display the hierarchy of all the devices discovered by DDL, including iSCSI devices.

### To list all the devices including iSCSI

- ◆ Type the following command:

```
# vxddladm list
```

The following is a sample output:

```
HBA c2 (20:00:00:E0:8B:19:77:BE)
  Port c2_p0 (50:0A:09:80:85:84:9D:84)
    Target c2_p0_t0 (50:0A:09:81:85:84:9D:84)
      LUN c2t0d0s2
  . . .
HBA c3 (iqn.1986-03.com.sun:01:0003ba8ed1b5.45220f80)
  Port c3_p0 (10.216.130.10:3260)
    Target c3_p0_t0 (iqn.1992-08.com.netapp:sn.84188548)
      LUN c3t0d0s2
      LUN c3t0d1s2
    Target c3_t1 (iqn.1992-08.com.netapp:sn.84190939)
  . . .
```

## Listing all the Host Bus Adapters including iSCSI

You can obtain information about all the devices discovered by DDL including iSCSI devices. This includes the following information:

Driver	Driver controlling the HBA.
Firmware	Firmware version.
Discovery	The discovery method employed for the targets.
State	Whether the device is Online or Offline.
Address	The hardware address.

### To list all the Host Bus Adapters including iSCSI

- ◆ Type the following command:

```
# vxddladm list hbas
```

You can use this command to obtain all of the HBAs, including iSCSI devices, configured on the system. The following is a sample output:

```
HBA-ID Driver Firmware Discovery State Address
-----
c2 qlc v.3.3.20 IPX Fabric Online 20:00:00:E0:8B:19:77:BE
c3 iscsi - iSNS(10.216.130.10) Online iqn.1986-03.com.sun:01:0003ba8ed1b5.45220f8
```

## Listing the ports configured on a Host Bus Adapter

You can obtain information about all the ports configured on an HBA. The display includes the following information:

HBA-ID	The parent HBA.
State	Whether the device is Online or Offline.
Address	The hardware address.

**To list the ports configured on a Host Bus Adapter**

- ◆ Type the following command:

```
# vxddladm list ports
```

You can use this command to obtain the ports configured on an HBA. The following is a sample output:

PortID	HBA-ID	State	Address
c2_p0	c2	Online	50:0A:09:80:85:84:9D:84
c3_p0	c3	Online	10.216.130.10:3260

**Listing the targets configured from a Host Bus Adapter or port**

You can obtain information about all the targets configured from a Host Bus Adapter. This includes the following information:

- Alias                                    The alias name, if available.
- HBA-ID                                 Parent HBA or port.
- State                                   Whether the device is Online or Offline.
- Address                                The hardware address.

**To list the targets**

- ◆ To list all of the targets, use the following command:

```
# vxddladm list targets
```

The following is a sample output:

TgtID	Alias	HBA-ID	State	Address
c2_p0_t0	-	c2	Online	50:0A:09:80:85:84:9D:84
c3_p0_t1	-	c3	Online	iqn.1992-08.com.netapp:sn.84190939

**To list the targets configured from a Host Bus Adapter or port**

- ◆ You can filter based on a HBA or port, using the following command:

```
# vxddladm list targets [hba=hba_name|port=port_name]
```

For example, to obtain the targets configured from the specified HBA:

```
# vxddladm list targets hba=c2
```

TgtID	Alias	HBA-ID	State	Address
c2_p0_t0	-	c2	Online	50:0A:09:80:85:84:9D:84

**Listing the devices configured from a Host Bus Adapter and target**

You can obtain information about all the devices configured from a Host Bus Adapter. This includes the following information:

Target-ID	The parent target.
State	Whether the device is Online or Offline.
DDL status	Whether the device is claimed by DDL. If claimed, the output also displays the ASL name.

**To list the devices configured from a Host Bus Adapter**

- ◆ To obtain the devices configured, use the following command:

```
# vxddladm list devices
```

Device	Target-ID	State	DDL status (ASL)
c2t0d2s2	c2_p0_t0	Online	CLAIMED (libvxemc.so)
c3t1d2s2	c3_p0_t1	Online	SKIPPED
c4t1d2s2	c4_p0_t1	Offline	ERROR
c4t1d2s2	c4_p0_t2	Online	EXCLUDED
c4t5d2s2	c4_p0_t5	Offline	MASKED

**To list the devices configured from a Host Bus Adapter and target**

- ◆ To obtain the devices configured from a particular HBA and target, use the following command:

```
# vxddladm list devices target=target_name
```



## Getting or setting the iSCSI operational parameters

DDL provides an interface to set and display certain parameters that affect the performance of the iSCSI device path. However, the underlying OS framework must support the ability to set these values. The `vxddladm set` command returns an error if the OS support is not available.

**Table 3-2** Parameters for iSCSI devices

Parameter	Default value	Minimum value	Maximum value
DataPDUInOrder	yes	no	yes
DataSequenceInOrder	yes	no	yes
DefaultTime2Retain	20	0	3600
DefaultTime2Wait	2	0	3600
ErrorRecoveryLevel	0	0	2
FirstBurstLength	65535	512	16777215
InitialR2T	yes	no	yes
ImmediateData	yes	no	yes
MaxBurstLength	262144	512	16777215
MaxConnections	1	1	65535
MaxOutStandingR2T	1	1	65535
MaxRecvDataSegmentLength	8182	512	16777215

To get the iSCSI operational parameters on the initiator for a specific iSCSI target

- ◆ Type the following commands:

```
# vxddladm getiscsi target=tgt-id {all | parameter}
```

You can use this command to obtain all the iSCSI operational parameters. The following is a sample output:

```
# vxddladm getiscsi target=c2_p2_t0
```

PARAMETER	CURRENT	DEFAULT	MIN	MAX
DataPDUInOrder	yes	yes	no	yes
DataSequenceInOrder	yes	yes	no	yes
DefaultTime2Retain	20	20	0	3600
DefaultTime2Wait	2	2	0	3600
ErrorRecoveryLevel	0	0	0	2
FirstBurstLength	65535	65535	512	16777215
InitialR2T	yes	yes	no	yes
ImmediateData	yes	yes	no	yes
MaxBurstLength	262144	262144	512	16777215
MaxConnections	1	1	1	65535
MaxOutStandingR2T	1	1	1	65535
MaxRecvDataSegmentLength	8192	8182	512	16777215

To set the iSCSI operational parameters on the initiator for a specific iSCSI target

- ◆ Type the following command:

```
# vxddladm setiscsi target=tgt-id
  parameter=value
```

## Listing all supported disk arrays

Use this procedure to obtain values for the `vid` and `pid` attributes that are used with other forms of the `vxddladm` command.

To list all supported disk arrays

- ◆ Type the following command:

```
# vxddladm listsupport all
```

## Excluding support for a disk array library

### To exclude support for a disk array library

- ◆ Type the following command:

```
# vxddladm excludearray libname=libvxenc.so
```

This example excludes support for disk arrays that depends on the library `libvxenc.so`. You can also exclude support for disk arrays from a particular vendor, as shown in this example:

```
# vxddladm excludearray vid=ACME pid=X1
```

See the `vxddladm(1M)` manual page.

## Re-including support for an excluded disk array library

### To re-include support for an excluded disk array library

- ◆ If you have excluded support for all arrays that depend on a particular disk array library, you can use the `includearray` keyword to remove the entry from the exclude list, as shown in the following example:

```
# vxddladm includearray libname=libvxenc.so
```

This command adds the array library to the database so that the library can once again be used in device discovery. If `vxconfigd` is running, you can use the `vxdisk scandisks` command to discover the arrays and add their details to the database.

## Listing excluded disk arrays

### To list all disk arrays that are currently excluded from use by VxVM

- ◆ Type the following command:

```
# vxddladm listexclude
```

## Listing supported disks in the DISKS category

### To list disks that are supported in the `DISKS` (JBOD) category

- ◆ Type the following command:

```
# vxddladm listjbod
```

## Displaying details about a supported array library

```
# vxddladm listsupport libname=library_name.so
```

To display details about a supported array library

- ◆ Type the following command:

```
# vxddladm listsupport libname=library_name.so
```

This command displays the vendor ID (VID), product IDs (PIDs) for the arrays, array types (for example, A/A or A/P), and array names. The following is sample output.

```
# vxddladm listsupport libname=libvxfujitsu.so
ATTR_NAME                ATTR_VALUE
=====
LIBNAME                   libvxfujitsu.so
VID                       vendor
PID                       GR710, GR720, GR730
                           GR740, GR820, GR840
ARRAY_TYPE                A/A, A/P
ARRAY_NAME                FJ_GR710, FJ_GR720, FJ_GR730
                           FJ_GR740, FJ_GR820, FJ_GR840
```

## Adding unsupported disk arrays to the DISKS category

Disk arrays should be added as JBOD devices if no ASL is available for the array.

JBODs are assumed to be Active/Active (A/A) unless otherwise specified. If a suitable ASL is not available, an A/A-A, A/P or A/PF array must be claimed as an Active/Passive (A/P) JBOD to prevent path delays and I/O failures. If a JBOD is ALUA-compliant, it is added as an ALUA array.

See [“How DMP works”](#) on page 165.

---

**Warning:** This procedure ensures that Dynamic Multipathing (DMP) is set up correctly on an array that is not supported by Veritas Volume Manager. Otherwise, Veritas Volume Manager treats the independent paths to the disks as separate devices, which can result in data corruption.

---

## To add an unsupported disk array to the DISKS category

- 1 Use the following command to identify the vendor ID and product ID of the disks in the array:

```
# /etc/vx/diag.d/vxscsiinq device_name
```

where *device\_name* is the device name of one of the disks in the array. Note the values of the vendor ID (VID) and product ID (PID) in the output from this command. For Fujitsu disks, also note the number of characters in the serial number that is displayed.

The following example shows the output for the example disk with the device name `/dev/rdisk/c1t20d0s2`

```
# /etc/vx/diag.d/vxscsiinq /dev/rdisk/c1t20d0s2

Vendor id (VID)       : SEAGATE
Product id (PID)     : ST318404LSUN18G
Revision              : 8507
Serial Number         : 0025T0LA3H
```

In this example, the vendor ID is SEAGATE and the product ID is ST318404LSUN18G.

- 2 Stop all applications, such as databases, from accessing VxVM volumes that are configured on the array, and unmount all file systems and checkpoints that are configured on the array.
- 3 If the array is of type A/A-A, A/P or A/PF, configure it in autotrespass mode.
- 4 Enter the following command to add a new JBOD category:

```
# vxddladm addjbod vid=vendorid [pid=productid] \  
[serialnum=opcode/pagecode/offset/length]  
[cabinetnum=opcode/pagecode/offset/length] policy={aa|ap}
```

where *vendorid* and *productid* are the VID and PID values that you found from the previous step. For example, *vendorid* might be FUJITSU, IBM, or SEAGATE. For Fujitsu devices, you must also specify the number of characters in the serial number as the argument to the `length` argument (for example, 10). If the array is of type A/A-A, A/P or A/PF, you must also specify the `policy=ap` attribute.

Continuing the previous example, the command to define an array of disks of this type as a JBOD would be:

```
# vxddladm addjbod vid=SEAGATE pid=ST318404LSUN18G
```

**Discovering and configuring newly added disk devices**

- 5 Use the `vxctl enable` command to bring the array under VxVM control.

```
# vxctl enable
```

See [“Enabling discovery of new disk arrays”](#) on page 91.

- 6 To verify that the array is now supported, enter the following command:

```
# vxddladm listjbod
```

The following is sample output from this command for the example array:

VID	PID	SerialNum (Cmd/PageCode/off/len)	CabinetNum (Cmd/PageCode/off/len)	Policy
SEAGATE	ALL PIDs	18/-1/36/12	18/-1/10/11	Disk
SUN	SESS01	18/-1/36/12	18/-1/12/11	Disk

- 7 To verify that the array is recognized, use the `vxdmpadm listenclosure` command as shown in the following sample output for the example array:

```
# vxdmpadm listenclosure
ENCLR_NAME      ENCLR_TYPE      ENCLR_SNO      STATUS
=====
OTHER_DISKS     OTHER_DISKS     OTHER_DISKS     CONNECTED
Disk            Disk            DISKS           CONNECTED
```

The enclosure name and type for the array are both shown as being set to `Disk`. You can use the `vxdisk list` command to display the disks in the array:

```
# vxdisk list
DEVICE  TYPE      DISK      GROUP      STATUS
Disk_0  auto:none -         -         online invalid
Disk_1  auto:none -         -         online invalid
...
```

- 8 To verify that the DMP paths are recognized, use the `vxdmpadm getdmpnode` command as shown in the following sample output for the example array:

```
# vxdmpadm getdmpnode enclosure=Disk
NAME      STATE      ENCLR-TYPE  PATHS  ENBL  DSBL  ENCLR-NAME
=====
Disk_0    ENABLED    Disk        2      2     0     Disk
Disk_1    ENABLED    Disk        2      2     0     Disk
...
```

This shows that there are two paths to the disks in the array.

For more information, enter the command `vxddladm help addjbod`.

See the `vxddladm(1M)` manual page.

See the `vxdmpadm(1M)` manual page.

## Removing disks from the DISKS category

To remove disks from the `DISKS` category

- ◆ Use the `vxddladm` command with the `rmjbod` keyword. The following example illustrates the command for removing disks supplied by the vendor, Seagate:

```
# vxddladm rmjbod vid=SEAGATE
```

## Foreign devices

DDL may not be able to discover some devices that are controlled by third-party drivers, such as those that provide multipathing or RAM disk capabilities. For these devices it may be preferable to use the multipathing capability that is provided by the third-party drivers for some arrays rather than using the Dynamic Multipathing (DMP) feature. Such foreign devices can be made available as simple disks to VxVM by using the `vxddladm addforeign` command. This also has the effect of bypassing DMP for handling I/O. The following example shows how to add entries for block and character devices in the specified directories:

```
# vxddladm addforeign blockdir=/dev/foo/dsk \  
  chardir=/dev/foo/rdisk
```

By default, this command suppresses any entries for matching devices in the OS-maintained device tree that are found by the autodiscovery mechanism. You can override this behavior by using the `-f` and `-n` options as described on the `vxddladm(1M)` manual page.

After adding entries for the foreign devices, use either the `vxdisk scandisks` or the `vxctl enable` command to discover the devices as simple disks. These disks then behave in the same way as autoconfigured disks.

The foreign device feature was introduced in VxVM 4.0 to support non-standard devices such as RAM disks, some solid state disks, and pseudo-devices such as EMC PowerPath.

Foreign device support has the following limitations:

- A foreign device is always considered as a disk with a single path. Unlike an autodiscovered disk, it does not have a DMP node.
- It is not supported for shared disk groups in a clustered environment. Only standalone host systems are supported.
- It is not supported for Persistent Group Reservation (PGR) operations.
- It is not under the control of DMP, so enabling of a failed disk cannot be automatic, and DMP administrative commands are not applicable.
- Enclosure information is not available to VxVM. This can reduce the availability of any disk groups that are created using such devices.
- The I/O Fencing and Cluster File System features are not supported for foreign devices.

If a suitable ASL is available and installed for an array, these limitations are removed.

See [“Third-party driver coexistence”](#) on page 91.



## Disks under VxVM control

When you add a disk to a system that is running VxVM, you need to put the disk under VxVM control so that VxVM can control the space allocation on the disk.

See [“Adding a disk to VxVM”](#) on page 115.

Unless you specify a disk group, VxVM places new disks in a default disk group according to the rules for determining the default disk group.

See [“Rules for determining the default disk group”](#) on page 222.

The method by which you place a disk under VxVM control depends on the following circumstances:

- If the disk is new, it must be initialized and placed under VxVM control. You can use the menu-based `vxdiskadm` utility to do this.

---

**Warning:** Initialization destroys existing data on disks.

---

- If the disk is not needed immediately, it can be initialized (but not added to a disk group) and reserved for future use. To do this, enter `none` when asked to name a disk group. Do not confuse this type of “spare disk” with a hot-relocation spare disk.
- If the disk was previously initialized for future use by VxVM, it can be reinitialized and placed under VxVM control.
- If the disk was previously in use, but not under VxVM control, you may wish to preserve existing data on the disk while still letting VxVM take control of the disk. This can be accomplished using encapsulation. Encapsulation preserves existing data on disks.
- Multiple disks on one or more controllers can be placed under VxVM control simultaneously. Depending on the circumstances, all of the disks may not be processed the same way.

It is possible to configure the `vxdiskadm` utility not to list certain disks or controllers as being available. For example, this may be useful in a SAN environment where disk enclosures are visible to a number of separate systems.

To exclude a device from the view of VxVM, select `Prevent multipathing/Suppress devices from VxVM’s view` from the `vxdiskadm` main menu.

See [“Disabling multipathing and making devices invisible to VxVM”](#) on page 172.

## VxVM coexistence with SVM and ZFS

Solaris Volume Manager (SVM) is a logical volume manager software provided by Sun. ZFS is a type of file system presenting a pooled storage model that Sun developed. File systems can directly draw from a common storage pool (zpool). Veritas Volume Manager (VxVM) can be used on the same system as SVM and ZFS disks.

VxVM protects devices in use by SVM or ZFS from any VxVM operations that may overwrite the disk. These operations include initializing the disk for use by VxVM or encapsulating the disk. If you attempt to perform one of these VxVM operations a device that is in use by SVM or ZFS, VxVM displays an error message.

Before you can manage an SVM disk or a ZFS disk with VxVM, you must remove it from SVM or ZFS control. Similarly, to begin managing a VxVM disk with SVM or ZFS, you must remove the disk from VxVM control.

### To determine if a disk is in use by SVM or ZFS

- ◆ Use the `vxdisk list` command:

```
# vxdisk list
DEVICE                TYPE                DISK    GROUP    STATUS
c1t0d0s2              auto:none           -       -        online invalid
c1t1d0s2              auto:none           -       -        online invalid
c2t5006016130603AE5d2s2 auto:ZFS            -       -        ZFS
c2t5006016130603AE5d3s2 auto:SVM            -       -        SVM
c2t5006016130603AE5d4s2 auto:cdsdisk        -       -        online
c2t5006016130603AE5d5s2 auto:cdsdisk        -       -        online
```

### To reuse a VxVM disk as a ZFS disk or an SVM disk

- 1 If the disk is in a disk group, remove the disk from the disk group or destroy the disk group.

To remove the disk from the disk group:

```
# vxdg [-g diskgroup] rmdisk diskname
```

To destroy the disk group:

```
# vxdg destroy diskgroup
```

- 2 Remove the disk from VxVM control

```
# /use/lib/vxvm/bin/vxdiskunsetup diskname
```

- 3 You can now initialize the disk as a SVM/ZFS device using ZFS/SVM tools.

See the Sun documentation for details.

You must perform step 1 and step 2 in order for VxVM to recognize a disk as SVM or ZFS device.

### To reuse a ZFS disk or an SVM disk as a VxVM disk

- 1 Remove the disk from the zpool or SVM metadvice, or destroy the zpool or SVM metadvice.

See the Sun documentation for details.

- 2 Clear the signature block using the `dd` command:

```
# dd if=/dev/zero of=/dev/rdisk/c#t#d#s# oseek=16 bs=512 count=1
```

Where `c#t#d#s#` is the disk slice on which the ZFS device or the SVM device is configured. If the whole disk is used as the ZFS device, clear the signature block on slice 0.

- 3 You can now initialize the disk as a VxVM device using the `vxdiskadm` command or the `vxdisksetup` command.

## Changing the disk-naming scheme

You can either use enclosure-based naming for disks or the operating system's naming scheme. VxVM commands display device names according the current naming scheme.

The default naming scheme is enclosure-based naming (EBN). When you install or upgrade a Storage Foundation product, the naming scheme is set to

enclosure-based naming, with the following exception. If you explicitly set the naming scheme for an existing installation to operating system-based naming, the setting is preserved when you upgrade. That is, if you used the `vxddladm set namingscheme=osn` command for the existing installation, the upgraded 5.1 product retains the operating system-based naming.

---

**Note:** Devices with very long device names (longer than 31 characters) are represented by enclosure-based names regardless of the naming scheme. If the OS-based names include WWN identifiers, the device name displays with the WWN identifier as long as the device name is less than 31 characters. If any device name is longer than 31 characters, that device name displays with an enclosure name.

---

### To change the disk-naming scheme

- ◆ Select `Change the disk naming scheme` from the `vxdiskadm` main menu to change the disk-naming scheme that you want VxVM to use. When prompted, enter `y` to change the naming scheme.

This restarts the `vxconfigd` daemon to bring the new disk naming scheme into effect.

Alternatively, you can change the naming scheme from the command line. Use the following command to select enclosure-based naming:

```
# vxddladm set namingscheme=ebn [persistence={yes|no}] \  
[use_avid=yes|no] [lowercase=yes|no]
```

Use the following command to select operating system-based naming:

```
# vxddladm set namingscheme=osn [persistence={yes|no}] \  
[lowercase=yes|no]
```

The optional `persistence` argument allows you to select whether the names of disk devices that are displayed by VxVM remain unchanged after disk hardware has been reconfigured and the system rebooted. By default, enclosure-based naming is persistent. Operating system-based naming is not persistent by default.

By default, the names of the enclosure are converted to lowercase, regardless of the case of the name specified by the ASL. The enclosure-based device names are therefore in lower case. Set the `lowercase=no` option to suppress the conversion to lowercase.

For enclosure-based naming, the `use_avid` option specifies whether the Array Volume ID is used for the index number in the device name. By default, `use_avid=yes`, indicating the devices are named as *enclosure\_avid*. If `use_avid` is set to `no`, DMP devices are named as *enclosure\_index*. The index number is assigned after the devices are sorted by LUN serial number.

The change is immediate whichever method you use.

See [“Regenerating persistent device names”](#) on page 110.

## Displaying the disk-naming scheme

VxVM disk naming can be operating-system based naming or enclosure-based naming. This command displays whether the VxVM disk naming scheme is currently set. It also displays the attributes for the disk naming scheme, such as whether persistence is enabled.

To display the current disk-naming scheme and its mode of operations, use the following command:

```
# vxddladm get namingscheme
```

See [“Disk device naming in VxVM”](#) on page 83.

## Regenerating persistent device names

The persistent device naming feature makes the names of disk devices persistent across system reboots. DDL assigns device names according to the persistent device name database.

If operating system-based naming is selected, each disk name is usually set to the name of one of the paths to the disk. After hardware reconfiguration and a subsequent reboot, the operating system may generate different names for the paths to the disks. Therefore, the persistent device names may no longer correspond to the actual paths. This does not prevent the disks from being used, but the association between the disk name and one of its paths is lost.

Similarly, if enclosure-based naming is selected, the device name depends on the name of the enclosure and an index number. If a hardware configuration changes the order of the LUNs exposed by the array, the persistent device name may not reflect the current index.

### To regenerate persistent device names

- ◆ To regenerate the persistent names repository, use the following command:

```
# vxddladm [-c] assign names
```

The `-c` option clears all user-specified names and replaces them with autogenerated names.

If the `-c` option is not specified, existing user-specified names are maintained, but OS-based and enclosure-based names are regenerated.

The disk names now correspond to the new path names.

## Changing device naming for TPD-controlled enclosures

The feature to change device naming is available only if the disk-naming scheme is set to use operating system-based naming, and the TPD-controlled enclosure does not contain fabric disks.

### To change device naming for TPD-controlled enclosures

- ◆ For disk enclosures that are controlled by third-party drivers (TPD) whose coexistence is supported by an appropriate ASL, the default behavior is to

assign device names that are based on the TPD-assigned node names. You can use the `vxddm adm` command to switch between these names and the device names that are known to the operating system:

```
# vxddm adm setattr enclosure enclosure tpdmode=native|pseudo
```

The argument to the `tpdmode` attribute selects names that are based on those used by the operating system (`native`), or TPD-assigned node names (`pseudo`).

The use of this command to change between TPD and operating system-based naming is illustrated in the following example for the enclosure named `EMC0`:

```
# vxdisk list
```

DEVICE	TYPE	DISK	GROUP	STATUS
emcpower10s2	auto:sliced	disk1	mydg	online
emcpower11s2	auto:sliced	disk2	mydg	online
emcpower12s2	auto:sliced	disk3	mydg	online
emcpower13s2	auto:sliced	disk4	mydg	online
emcpower14s2	auto:sliced	disk5	mydg	online
emcpower15s2	auto:sliced	disk6	mydg	online
emcpower16s2	auto:sliced	disk7	mydg	online
emcpower17s2	auto:sliced	disk8	mydg	online
emcpower18s2	auto:sliced	disk9	mydg	online
emcpower19s2	auto:sliced	disk10	mydg	online

```
# vxddm adm setattr enclosure EMC0 tpdmode=native
```

```
# vxdisk list
```

DEVICE	TYPE	DISK	GROUP	STATUS
c6t0d10s2	auto:sliced	disk1	mydg	online
c6t0d11s2	auto:sliced	disk2	mydg	online
c6t0d12s2	auto:sliced	disk3	mydg	online
c6t0d13s2	auto:sliced	disk4	mydg	online
c6t0d14s2	auto:sliced	disk5	mydg	online
c6t0d15s2	auto:sliced	disk6	mydg	online
c6t0d16s2	auto:sliced	disk7	mydg	online
c6t0d17s2	auto:sliced	disk8	mydg	online
c6t0d18s2	auto:sliced	disk9	mydg	online
c6t0d19s2	auto:sliced	disk10	mydg	online

If `tpdmode` is set to `native`, the path with the smallest device number is displayed.

## Simple or nopriv disks with enclosure-based naming

If you change from OS-based naming to enclosure-based naming, simple or nopriv disks may be put in the `error` state and cause VxVM objects on those disks to fail.

You can use the `vxdarestore` command to handle simple and nopriv disk failures that arise from changing to the enclosure-based naming scheme. You do not need to use this command if your system does not have any simple or nopriv disks, or if the devices on which any simple or nopriv disks are present are not automatically configured by VxVM (for example, non-standard disk devices such as ramdisks).

---

**Note:** You cannot run `vxdarestore` if OS-based naming is in use. Additionally, `vxdarestore` does not handle failures on simple or nopriv disks that are caused by renaming enclosures, by hardware reconfiguration that changes device names, or by changing the naming scheme on a system that includes persistent sliced disk records.

---

See [“Removing the error state for simple or nopriv disks in the boot disk group”](#) on page 112.

See [“Removing the error state for simple or nopriv disks in non-boot disk groups”](#) on page 113.

See the `vxdarestore(1M)` manual page.

### Removing the error state for simple or nopriv disks in the boot disk group

If the boot disk group (usually aliased as `bootdg`) is comprised of only simple and/or nopriv disks, the `vxconfigd` daemon goes into the disabled state after the naming scheme change.

**To remove the error state for simple or nopriv disks in the boot disk group**

- 1 Use `vxdiskadm` to change back to `c#t#d#s#` naming.
- 2 Enter the following command to restart the VxVM configuration daemon:

```
# vxconfigd -kr reset
```

- 3 If you want to use enclosure-based naming, use `vxdiskadm` to add a sliced disk to the `bootdg` disk group, change back to the enclosure-based naming scheme, and then run the following command:

```
# /etc/vx/bin/vxdarestore
```



## Removing the error state for simple or nopriv disks in non-boot disk groups

If an imported disk group, other than `bootdg`, is comprised of only simple and/or nopriv disks, the disk group is in the “online `dgdisabled`” state after the change to the enclosure-based naming scheme.

To remove the error state for simple or nopriv disks in non-boot disk groups

- 1 Deport the disk group using the following command:

```
# vxdg deport diskgroup
```

- 2 Use the `vxdarestore` command to restore the failed disks, and to recover the objects on those disks:

```
# /etc/vx/bin/vxdarestore
```

- 3 Re-import the disk group using the following command:

```
# vxdg import diskgroup
```

## Discovering the association between enclosure-based disk names and OS-based disk names

To discover the association between enclosure-based disk names and OS-based disk names

- ◆ If you enable enclosure-based naming, and use the `vxprint` command to display the structure of a volume, it shows enclosure-based disk device names (disk access names) rather than OS-based names. To discover the operating system-based names that are associated with a given enclosure-based disk name, use either of the following commands:

```
# vxdisk list enclosure-based_name  
# vxdmpadm getsubpaths dmpnodename=enclosure-based_name
```

For example, to find the physical device that is associated with disk `ENCO_21`, the appropriate commands would be:

```
# vxdisk list ENCO_21  
# vxdmpadm getsubpaths dmpnodename=ENCO_21
```

To obtain the full pathname for the block and character disk device from these commands, append the displayed device name to `/dev/vx/dmp` or `/dev/vx/rdmp`.

## Disk installation and formatting

Depending on the hardware capabilities of your disks and of your system, you may either need to shut down and power off your system before installing the disks, or you may be able to hot-insert the disks into the live system. Many operating systems can detect the presence of the new disks on being rebooted. If the disks are inserted while the system is live, you may need to enter an operating system-specific command to notify the system.

If the disks require low or intermediate-level formatting before use, use the operating system-specific formatting command to do this.

For Solaris SPARC systems, if a disk is not formatted, the status field in the `vxdisk list` output shows as `noLabel`. The disk must be formatted before you add it to VxVM control.

---

**Note:** SCSI disks are usually preformatted. Reformatting is needed only if the existing formatting has become damaged.

---

See “[Displaying or changing default disk layout attributes](#)” on page 115.

See “[Adding a disk to VxVM](#)” on page 115.

## Displaying or changing default disk layout attributes

To display or change the default values for initializing the layout of disks

- ◆ Select `Change/display` the default disk layout from the `vxdiskadm` main menu. For disk initialization, you can change the default format and the default length of the private region. The attribute settings for initializing disks are stored in the file, `/etc/default/vxdisk`.

See the `vxdisk(1M)` manual page.

For disk encapsulation, you can additionally change the offset values for both the private and public regions. The attribute settings for encapsulating disks are stored in the file, `/etc/default/vxencap`.

See the `vxencap(1M)` manual page.

## Adding a disk to VxVM

Formatted disks being placed under VxVM control may be new or previously used outside VxVM. The set of disks can consist of all disks on the system, all disks on a controller, selected disks, or a combination of these.

Depending on the circumstances, all of the disks may not be processed in the same way.

For example, some disks may be initialized, while others may be encapsulated to preserve existing data on the disks.

When initializing multiple disks at one time, it is possible to exclude certain disks or certain controllers.

You can also exclude certain disks or certain controllers when encapsulating multiple disks at one time.

To exclude a device from the view of VxVM, select `Prevent multipathing/Suppress devices` from VxVM's view from the `vxdiskadm` main menu.

---

**Warning:** Initialization does not preserve the existing data on the disks.

---

See “[Disabling multipathing and making devices invisible to VxVM](#)” on page 172.

**To initialize disks for VxVM use**

- 1 Select `Add` or `initialize` one or more disks from the `vxdiskadm` main menu.
- 2 At the following prompt, enter the disk device name of the disk to be added to VxVM control (or enter `list` for a list of disks):

```
Select disk devices to add:
[<pattern-list>,all,list,q,?]
```

The *pattern-list* can be a single disk, or a series of disks and/or controllers (with optional targets). If *pattern-list* consists of multiple items, separate them using white space. For example, specify four disks at separate target IDs on controller 3 as follows:

```
c3t0d0 c3t1d0 c3t2d0 c3t3d0
```

If you enter `list` at the prompt, the `vxdiskadm` program displays a list of the disks available to the system:

```
DEVICE          DISK          GROUP        STATUS
c0t0d0          mydg01       mydg         online
c0t1d0          mydg02       mydg         online
c0t2d0          mydg03       mydg         online
c0t3d0          -            -            online
c1t0d0          mydg10       mydg         online
c1t0d1          -            -            online invalid
.
.
.
c3t0d0          -            -            online invalid
sena0_0        mydg33       mydg         online
sena0_1        mydg34       mydg         online
sena0_2        mydg35       mydg         online
```

The phrase `online invalid` in the `STATUS` line indicates that a disk has yet to be added or initialized for VxVM control. Disks that are listed as `online` with a disk name and disk group are already under VxVM control.

Enter the device name or pattern of the disks that you want to initialize at the prompt and press Return.

- 3** To continue with the operation, enter `y` (or press Return) at the following prompt:

```
Here are the disks selected. Output format: [Device]
list of device names
```

```
Continue operation? [y,n,q,?] (default: y) y
```

- 4** At the following prompt, specify the disk group to which the disk should be added, or `none` to reserve the disks for future use:

```
You can choose to add these disks to an existing disk group,
a new disk group, or you can leave these disks available for use
by future add or replacement operations. To create a new disk
group, select a disk group name that does not yet exist. To
leave the disks available for future use, specify a disk group
name of none.
```

```
Which disk group [<group>,none,list,q,?]
```

- 5** If you specified the name of a disk group that does not already exist, `vxdiskadm` prompts for confirmation that you really want to create this new disk group:

```
There is no active disk group named disk group name.
```

```
Create a new group named disk group name? [y,n,q,?]
(default: y) y
```

You are then prompted to confirm whether the disk group should support the Cross-platform Data Sharing (CDS) feature:

```
Create the disk group as a CDS disk group? [y,n,q,?]
(default: n)
```

If the new disk group may be moved between different operating system platforms, enter `y`. Otherwise, enter `n`.

- 6** At the following prompt, either press Return to accept the default disk name or enter `n` to allow you to define your own disk names:

```
Use default disk names for the disks? [y,n,q,?] (default: y) n
```

- 7** When prompted whether the disks should become hot-relocation spares, enter **n** (or press Return):

```
Add disks as spare disks for disk group name? [y,n,q,?]
(default: n) n
```

- 8** When prompted whether to exclude the disks from hot-relocation use, enter **n** (or press Return).

```
Exclude disks from hot-relocation use? [y,n,q,?]
(default: n) n
```

- 9** You are next prompted to choose whether you want to add a site tag to the disks:

```
Add site tag to disks? [y,n,q,?] (default: n)
```

A site tag is usually applied to disk arrays or enclosures, and is not required unless you want to use the Remote Mirror feature.

If you enter **y** to choose to add a site tag, you are prompted to the site name at step 11.

- 10** To continue with the operation, enter **y** (or press Return) at the following prompt:

```
The selected disks will be added to the disk group
disk group name with default disk names.
list of device names
Continue with operation? [y,n,q,?] (default: y) y
```

- 11** If you chose to tag the disks with a site in step 9, you are now prompted to enter the site name that should be applied to the disks in each enclosure:

```
The following disk(s):
list of device names

belong to enclosure(s):
list of enclosure names

Enter site tag for disks on enclosure enclosure name
[<name>,q,?] site_name
```

**12** If you see the following prompt, it lists any disks that have already been initialized for use by VxVM:

```
The following disk devices appear to have been initialized
already.
```

```
The disks are currently available as replacement disks.
```

```
Output format: [Device]
```

```
list of device names
```

```
Use these devices? [Y,N,S(lect),q,?] (default: Y) Y
```

This prompt allows you to indicate “yes” or “no” for all of these disks (Y or N) or to select how to process each of these disks on an individual basis (s).

If you are sure that you want to reinitialize all of these disks, enter Y at the following prompt:

```
VxVM NOTICE V-5-2-366 The following disks you selected for use
appear to already have been initialized for the Volume
Manager. If you are certain the disks already have been
initialized for the Volume Manager, then you do not need to
reinitialize these disk devices.
```

```
Output format: [Device]
```

```
list of device names
```

```
Reinitialize these devices? [Y,N,S(lect),q,?] (default: Y) Y
```

- 13** `vxdiskadm` may now indicate that one or more disks is a candidate for encapsulation. Encapsulation allows you to add an active disk to VxVM control and preserve the data on that disk. If you want to preserve the data on the disk, enter `y`. If you are sure that there is no data on the disk that you want to preserve, enter `n` to avoid encapsulation.

```
VxVM NOTICE V-5-2-355 The following disk device has a valid
partition table, but does not appear to have been initialized
for the Volume Manager. If there is data on the disk that
should NOT be destroyed you should encapsulate the existing
disk partitions as volumes instead of adding the disk as a new
disk.
```

```
Output format: [Device]
```

```
device name
```

```
Encapsulate this device? [y,n,q,?] (default: y)
```



- 14** If you choose to encapsulate the disk `vxdiskadm` confirms its device name and prompts you for permission to proceed. Enter `y` (or press Return) to continue encapsulation:

```
VxVM NOTICE V-5-2-311 The following disk device has been
selected for encapsulation.
Output format: [Device]
```

```
device name
```

```
Continue with encapsulation? [y,n,q,?] (default: y) y
vxdiskadm now displays an encapsulation status and informs you
that you must perform a shutdown and reboot as soon as
possible:
```

```
VxVM INFO V-5-2-333 The disk device device name will be
encapsulated and added to the disk group disk group name with the
disk name disk name.
```

You can now choose whether the disk is to be formatted as a CDS disk that is portable between different operating systems, or as a non-portable sliced or simple disk:

```
Enter the desired format [cdsdisk,sliced,simple,q,?]
(default: cdsdisk)
```

Enter the format that is appropriate for your needs. In most cases, this is the default format, `cdsdisk`.

At the following prompt, `vxdiskadm` asks if you want to use the default private region size of 65536 blocks (32MB). Press Return to confirm that you want to use the default value, or enter a different value. (The maximum value that you can specify is 524288 blocks.)

```
Enter desired private region length [<privlen>,q,?]
(default: 65536)
```

If you entered `cdsdisk` as the format, you are prompted for the action to be taken if the disk cannot be converted this format:

```
Do you want to use sliced as the format should cdsdisk fail?
[y,n,q,?] (default: y)
```

If you enter `y`, and it is not possible to encapsulate the disk as a CDS disk, it is encapsulated as a sliced disk. Otherwise, the encapsulation fails.

`vxdiskadm` then proceeds to encapsulate the disks. You should now reboot your system at the earliest possible opportunity, for example by running this command:

```
# shutdown -g0 -y -i6
```

The `/etc/vfstab` file is updated to include the volume devices that are used to mount any encapsulated file systems. You may need to update any other references in backup scripts, databases, or manually created swap devices. The original `/etc/vfstab` file is saved as `/etc/vfstab.prevm`.

- 15** If you choose not to encapsulate the disk `vxdiskadm` asks if you want to initialize the disk instead. Enter `y` to confirm this:

Instead of encapsulating, initialize? [y,n,q,?] (default: n) `yvxdiskadm` now confirms those disks that are being initialized and added to VxVM control with messages similar to the following. In addition, you may be prompted to perform surface analysis.

```
VxVM INFO V-5-2-205 Initializing device device name.
```

- 16** You can now choose whether the disk is to be formatted as a CDS disk that is portable between different operating systems, or as a non-portable sliced or simple disk:

```
Enter the desired format [cdsdisk,sliced,simple,q,?]  
(default: cdsdisk)
```

Enter the format that is appropriate for your needs. In most cases, this is the default format, `cdsdisk`.

- 17** At the following prompt, `vxdiskadm` asks if you want to use the default private region size of 65536 blocks (32MB). Press Return to confirm that you want to use the default value, or enter a different value. (The maximum value that you can specify is 524288 blocks.)

`vxdiskadm` then proceeds to add the disks.

```
VxVM INFO V-5-2-88 Adding disk device device name to disk group  
disk group name with disk name disk name.
```

```
.  
. .  
. .
```

- 18 If you choose not to use the default disk names, `vxdiskadm` prompts you to enter the disk name.
- 19 At the following prompt, indicate whether you want to continue to initialize more disks (y) or return to the `vxdiskadm` main menu (n):

```
Add or initialize other disks? [y,n,q,?] (default: n)
```

The default layout for disks can be changed.

See “[Displaying or changing default disk layout attributes](#)” on page 115.

## Disk reinitialization

You can reinitialize a disk that has previously been initialized for use by VxVM by putting it under VxVM control as you would a new disk.

See “[Adding a disk to VxVM](#)” on page 115.

---

**Warning:** Reinitialization does not preserve data on the disk. If you want to reinitialize the disk, make sure that it does not contain data that should be preserved.

---

If the disk you want to add has been used before, but not with VxVM, you can encapsulate the disk to preserve its information. If the disk you want to add has previously been under the control of Solaris Volume Manager, you can preserve the data it contains on a VxVM disk by the process of conversion.

## Using `vxdiskadd` to put a disk under VxVM control

To use the `vxdiskadd` command to put a disk under VxVM control.

- ◆ Type the following command:

```
# vxdiskadd disk
```

For example, to initialize the second disk on the first controller:

```
# vxdiskadd c0t1d0
```

The `vxdiskadd` command examines your disk to determine whether it has been initialized and also checks for disks that have been added to VxVM, and for other conditions.

The `vxdiskadd` command also checks for disks that can be encapsulated.

See [“Encapsulating a disk”](#) on page 126.

If you are adding an uninitialized disk, warning and error messages are displayed on the console by the `vxdiskadd` command. Ignore these messages. These messages should not appear after the disk has been fully initialized; the `vxdiskadd` command displays a success message when the initialization completes.

The interactive dialog for adding a disk using `vxdiskadd` is similar to that for `vxdiskadm`.

See [“Adding a disk to VxVM”](#) on page 115.

## RAM disk support in VxVM

Some systems support the creation of RAM disks. A RAM disk is a device made from system memory that looks like a small disk device. Often, the contents of a RAM disk are erased when the system is rebooted. RAM disks that are erased on reboot prevent VxVM from identifying physical disks. This is because information stored on the physical disks (now erased on reboot) is used to identify the disk.

`nopriv` devices have a special feature to support RAM disks: a volatile option which indicates to VxVM that the device contents do not survive reboots. Volatile devices receive special treatment on system startup. If a volume is mirrored, plexes made from volatile devices are always recovered by copying data from nonvolatile plexes.

To use a RAM disk with VxVM, both block and character device nodes must exist for the RAM disk.

## To create a RAM disk with VxVM

### 1 Create the RAM disk:

```
# ramdiskadm -a ramdiskname size
```

### 2 Create links to the RAM disk:

```
# ln -s /dev/ramdisk/ramdiskname /dev/dsk/ramdiskname  
# ln -s /dev/rramdisk/rramdiskname /dev/rdisk/rramdiskname
```

### 3 Add the RAM disk as a foreign device to VxVM:

```
# vxddladm addforeign blockpath=/dev/ramdiskname  
charpath=/dev/rramdiskname
```

### 4 Define the RAM disk using the `vxdisk define` command:

```
# vxdisk scandisks  
# vxdisk define ramdiskname type=nopriv volatile len=size
```

### 5 Add the RAM disk to a diskgroup:

```
# vxvg -g diskgroup adddisk ramdiskname
```

---

**Note:** An existing diskgroup must exist in order to validate configuration copies.

---

### 6 Create VxVM volumes on the RAM disk:

```
# vxassist -g diskgroup make volume size ramdiskname
```

Normally, VxVM does not start volumes that are formed entirely from plexes with volatile subdisks. That is because there is no plex that is guaranteed to contain the most recent volume contents.

Some RAM disks are used in situations where all volume contents are recreated after reboot. In these situations, you can force volumes formed from RAM disks to be started at reboot by using the following command:

```
# vxvol set startopts=norecov volume
```

This option can be used only with volumes of type `gen`.

See the `vxvol(1M)` manual page.

## Encapsulating a disk

---

**Warning:** Encapsulating a disk requires that the system be rebooted several times. Schedule performance of this procedure for a time when this does not inconvenience users.

---

This section describes how to encapsulate a disk for use in VxVM. Encapsulation preserves any existing data on the disk when the disk is placed under VxVM control.

To prevent the encapsulation from failing, make sure that the following conditions apply:

- The disk has two free partitions for the public and private regions.
- The disk has an `s2` slice.
- The disk has a small amount of free space (at least 1 megabyte at the beginning or end of the disk) that does not belong to any partition. If the disk being encapsulated is the root disk, and this does not have sufficient free space available, a similar sized portion of the swap partition is used instead.

Only encapsulate a root disk if you also intend to mirror it. There is no benefit in root-disk encapsulation for its own sake.

See “[Rootability](#)” on page 131.

Use the `format` or `fdisk` commands to obtain a printout of the root disk partition table before you encapsulate a root disk. For more information, see the appropriate manual pages. You may need this information should you subsequently need to recreate the original root disk.

You cannot grow or shrink any volume (`rootvol`, `usrvol`, `varvol`, `optvol`, `swapvol`, and so on) that is associated with an encapsulated root disk. This is because these volumes map to physical partitions on the disk, and these partitions must be contiguous..

---

**Warning:** If the root disk is encapsulated and the dump device is covered by the swap volume, it is not safe to use the `savecore -L` operation because this overwrites the swap area. Configure a dedicated dump device on a partition other than the swap area.

---

### To encapsulate a disk for use in VxVM

- 1 Select `Encapsulate` one or more disks from the `vxdiskadm` main menu.

Your system may use device names that differ from the examples shown here.

At the following prompt, enter the disk device name for the disks to be encapsulated:

```
Select disk devices to encapsulate:  
[<pattern-list>,all,list,q,?] device name
```

The *pattern-list* can be a single disk, or a series of disks and/or controllers (with optional targets). If *pattern-list* consists of multiple items, those items must be separated by white space.

If you do not know the address (device name) of the disk to be encapsulated, enter `l` or `list` at the prompt for a complete listing of available disks.

- 2 To continue the operation, enter `y` (or press Return) at the following prompt:

```
Here is the disk selected. Output format: [Device]  
device name
```

```
Continue operation? [y,n,q,?] (default: y) y
```

- 3 Select the disk group to which the disk is to be added at the following prompt:

You can choose to add this disk to an existing disk group or to a new disk group. To create a new disk group, select a disk group name that does not yet exist.

```
Which disk group [<group>,list,q,?]
```

- 4 At the following prompt, either press Return to accept the default disk name or enter a disk name:

```
Use a default disk name for the disk? [y,n,q,?] (default: y)
```

- 5 To continue with the operation, enter `y` (or press Return) at the following prompt:

```
The selected disks will be encapsulated and added to the
disk group name disk group with default disk names.
```

```
device name
```

```
Continue with operation? [y,n,q,?] (default: y) y
```

- 6 To confirm that encapsulation should proceed, enter `y` (or press Return) at the following prompt:

```
The following disk has been selected for encapsulation.
```

```
Output format: [Device]
```

```
device name
```

```
Continue with encapsulation? [y,n,q,?] (default: y) y
```

A message similar to the following confirms that the disk is being encapsulated for use in VxVM and tells you that a reboot is needed:

```
The disk device device name will be encapsulated and added to
the disk group diskgroup with the disk name diskgroup01.
```

- 7 For non-root disks, you can now choose whether the disk is to be formatted as a CDS disk that is portable between different operating systems, or as a non-portable sliced disk:

```
Enter the desired format [cdsdisk,sliced,q,?]
(default: cdsdisk)
```

Enter the format that is appropriate for your needs. In most cases, this is the default format, `cdsdisk`. Note that only the `sliced` format is suitable for use with root, boot or swap disks.

- 8 At the following prompt, `vxdiskadm` asks if you want to use the default private region size of 65536 blocks (32MB). Press Return to confirm that you want to use the default value, or enter a different value. (The maximum value that you can specify is 524288 blocks.)

```
Enter desired private region length [<privlen>,q,?]
(default: 65536)
```



- 9 If you entered `cdsdisk` as the format in step 7, you are prompted for the action to be taken if the disk cannot be converted this format:

```
Do you want to use sliced as the format should cdsdisk  
fail? [y,n,q,?] (default: y)
```

If you enter `y`, and it is not possible to encapsulate the disk as a CDS disk, it is encapsulated as a sliced disk. Otherwise, the encapsulation fails.

- 10 `vxdiskadm` then proceeds to encapsulate the disks. You should now reboot your system at the earliest possible opportunity, for example by running this command:

```
# shutdown -g0 -y -i6
```

The `/etc/vfstab` file is updated to include the volume devices that are used to mount any encapsulated file systems. You may need to update any other references in backup scripts, databases, or manually created swap devices. The original `/etc/vfstab` file is saved as `/etc/vfstab.prevm`.

- 11 At the following prompt, indicate whether you want to encapsulate more disks (`y`) or return to the `vxdiskadm` main menu (`n`):

```
Encapsulate other disks? [y,n,q,?] (default: n) n
```

The default layout that is used to encapsulate disks can be changed.

See “[Displaying or changing default disk layout attributes](#)” on page 115.

## Failure of disk encapsulation

Under some circumstances, encapsulation of a disk can fail because there is not enough free space available on the disk to accommodate the private region. If there is insufficient free space, the encapsulation process ends abruptly with an error message similar to the following:

```
VxVM ERROR V-5-2-338 The encapsulation operation failed with the  
following error:  
It is not possible to encapsulate device, for the following  
reason:  
<VxVM vx slicer ERROR V-5-1-1108 Unsupported disk layout.>
```

One solution is to configure the disk with the `nopriv` format.

See “[Using nopriv disks for encapsulation](#)” on page 130.

## Using nopriv disks for encapsulation

Encapsulation converts existing partitions on a specified disk to volumes. If any partitions contain file systems, their `/etc/vfstab` entries are modified so the file systems are mounted on volumes instead.

Disk encapsulation requires that enough free space be available on the disk (by default, 32 megabytes) for storing the private region that VxVM uses for disk identification and configuration information. This free space cannot be included in any other partitions.

See the `vxencap(1M)` manual page.

You can encapsulate a disk that does not have space available for the VxVM private region partition by using the `vxdisk` utility. To do this, configure the disk as a `nopriv` device that does not have a private region.

The drawback with using `nopriv` devices is that VxVM cannot track changes in the address or controller of the disk. Normally, VxVM uses identifying information stored in the private region on the physical disk to track changes in the location of a physical disk. Because `nopriv` devices do not have private regions and have no identifying information stored on the physical disk, tracking cannot occur.

One use of `nopriv` devices is to encapsulate a disk so that you can use VxVM to move data off the disk. When space has been made available on the disk, remove the `nopriv` device, and encapsulate the disk as a standard disk device.

A disk group cannot be formed entirely from `nopriv` devices. This is because `nopriv` devices do not provide space for storing disk group configuration information. Configuration information must be stored on at least one disk in the disk group.

## Creating a nopriv disk for encapsulation

---

**Warning:** Do not use `nopriv` disks to encapsulate a root disk. If insufficient free space exists on the root disk for the private region, part of the swap area can be used instead.

---

### To create a nopriv disk for encapsulation

- 1 If it does not exist already, set up a partition on the disk for the area that you want to access using VxVM.
- 2 Use the following command to map a VM disk to the partition:

```
# vxdisk define partition-device type=nopriv
```

where *partition-device* is the basename of the device in the `/dev/dsk` directory.

For example, to map partition 3 of disk device `c0t4d0`, use the following command:

```
# vxdisk define c0t4d0s3 type=nopriv
```

## Creating volumes for other partitions on a nopriv disk

### To create volumes for other partitions on a nopriv disk

- 1 Add the partition to a disk group.
- 2 Determine where the partition resides within the encapsulated partition.
- 3 If no data is to be preserved on the partition, use `vxassist` to create a volume with the required length.

---

**Warning:** By default, `vxassist` re-initializes the data area of a volume that it creates. If there is data to be preserved on the partition, do not use `vxassist`. Instead, create the volume with `vxmake` and start the volume with the command `vxvol init active`.

---

## Rootability

VxVM can place various files from the root file system, `swap` device, and other file systems on the root disk under VxVM control. This is called rootability. The root disk (that is, the disk containing the root file system) can be put under VxVM control through the process of encapsulation.

The root disk can be encapsulated using the `vxdiskadm` command.

See [“Encapsulating a disk”](#) on page 126.

Once encapsulated, the root disk can also be mirrored by using the `vxdiskadm` command.

See [“Mirroring an encapsulated root disk”](#) on page 134.

Encapsulation converts existing partitions on that disk to volumes. Once under VxVM control, the `root` and `swap` devices appear as volumes and provide the same characteristics as other VxVM volumes. A volume that is configured for use as a swap area is referred to as a swap volume, and a volume that contains the root file system is referred to as a root volume.

---

**Note:** Only encapsulate your root disk if you also intend to mirror it. There is no benefit in root-disk encapsulation for its own sake.

---

It is possible to mirror the `rootvol`, and `swapvol` volumes, as well as other parts of the root disk that are required for a successful boot of the system (for example, `/usr`). This provides complete redundancy and recovery capability in the event of disk failure. Without mirroring, the loss of the `root`, `swap`, or `usr` partition prevents the system from being booted from surviving disks.

Mirroring disk drives that are critical to booting ensures that no single disk failure renders the system unusable. A suggested configuration is to mirror the critical disk onto another available disk (using the `vxdiskadm` command). If the disk containing `root` and `swap` partitions fails, the system can be rebooted from a disk containing mirrors of these partitions.

Recovering a system after the failure of an encapsulated root disk requires the application of special procedures.

See the *Veritas Volume Manager Troubleshooting Guide*.

## Booting root volumes

When the operating system is booted, the `root` file system and `swap` area must be available for use before the `vxconfigd` daemon can load the VxVM configuration or start any volumes. During system startup, the operating system must see the `rootvol` and `swapvol` volumes as regular partitions so that it can access them as ordinary disk partitions.

Due to this restriction, each of the `rootvol` and `swapvol` plexes must be created from contiguous space on a disk that is mapped to a single partition. It is not possible to stripe, concatenate or span the plex of a `rootvol` or `swapvol` volume that is used for booting. Any mirrors of these plexes that are potentially bootable also cannot be striped, concatenated or spanned.

For information on how to configure your system BIOS to boot from a disk other than the default boot disk, refer to the documentation from your hardware vendor.

## Boot-time volume restrictions

When the operating system is booted, the `root` file system and `swap` area must be available for use before the `vxconfigd` daemon can load the VxVM configuration or start any volumes. During system startup, the operating system must see the `rootvol` and `swapvol` volumes as regular partitions so that it can access them as ordinary disk partitions.

Due to this restriction, each of the `rootvol` and `swapvol` plexes must be created from contiguous space on a disk that is mapped to a single partition. It is not possible to stripe, concatenate or span the plex of a `rootvol` or `swapvol` volume that is used for booting. Any mirrors of these plexes that are potentially bootable also cannot be striped, concatenated or spanned.

Volumes on the root disk have the following restrictions on their configuration:

- For the x64 platform, root encapsulation is supported for Update 1 and later releases of the Solaris 10 OS that include the GRUB boot loader.
- The root volume (`rootvol`) must exist in the disk group that is chosen to be the boot disk group, `bootdg`. Although other volumes named `rootvol` can be created in other disk groups, only the `rootvol` in `bootdg` can be used to boot the system.
- If the volumes that are required to boot the system span multiple disks, all these disks must be in the boot disk group.
- The `rootvol` and `swapvol` volumes always have minor device numbers 0 and 1 respectively. Other volumes on the root disk do not have specific minor device numbers.
- Restricted mirrors of volumes on the root disk have overlay partitions created for them. An overlay partition is one that exactly includes the disk space occupied by the restricted mirror. During boot, before the `rootvol`, `varvol`, `usrvol` and `swapvol` volumes are fully configured, the default volume configuration uses the overlay partition to access the data on the disk.
- Although it is possible to add a striped mirror to a `rootvol` device for performance reasons, you cannot stripe the primary plex or any mirrors of `rootvol` that may be needed for system recovery or booting purposes if the primary plex fails.
- `rootvol` and `swapvol` cannot be spanned or contain a primary plex with multiple noncontiguous subdisks. You cannot grow or shrink any volume associated with an encapsulated boot disk (`rootvol`, `usrvol`, `varvol`, `optvol`, `swapvol`, and so on) because these map to a physical underlying partition on the disk and must be contiguous. A workaround is to unencapsulate the boot

disk, repartition the boot disk as desired (growing or shrinking partitions as needed), and then re-encapsulating.

- When mirroring parts of the boot disk, the disk being mirrored to must be large enough to hold the data on the original plex, or mirroring may not work.
- The volumes on the root disk cannot use dirty region logging (DRL).

In addition to these requirements, it is a good idea to have at least one contiguous, (cylinder-aligned if appropriate) mirror for each of the volumes for `root`, `usr`, `var`, `opt` and `swap`. This makes it easier to convert these from volumes back to regular disk partitions (during an operating system upgrade, for example).

## Mirroring an encapsulated root disk

VxVM allows you to mirror the root volume and other areas needed for booting onto another disk. Mirroring the root volume enables you to recover from a failure of your root disk by replacing it with one of its mirrors.

For Sun x64 systems, mirroring a root disk creates a GRUB boot menu entry for the Primary and Alternate (mirror) Boot disk.

For Sun SPARC systems, after mirroring the root disk, you can configure the system to boot from the alternate boot drive to recover from a primary boot drive failure.

See the *Veritas Volume Manager Troubleshooting Guide* for more information about recovering from boot drive failure.

### To mirror your root disk onto another disk

- 1 Choose a disk that is at least as large as the existing `root` disk.
- 2 If the selected disk is not already under VxVM control, use the `vxdiskadd` or `vxdiskadm` command, or the Veritas Enterprise Administrator (VEA) to add it to the `bootdg` disk group. Ensure that you specify the `sliced` format for the disk.

- 3 Select **Mirror Volumes on a Disk** from the `vxdiskadm` main menu, or use the VEA to create a mirror of the root disk. Doing so automatically invokes the `vxmirror` command if the mirroring operation is performed on the `root` disk.

Alternatively, to mirror only those file systems on the root disk that are required to boot the system, run the following command:

```
# /etc/vx/bin/vxmirror altboot_disk
```

where `altboot_disk` is the disk media name of the mirror for the root disk. `vxmirror` creates a mirror for `rootvol` (the volume for the `root` file system on an alternate disk). The alternate `root` disk is configured to enable booting from it if the primary `root` disk fails.

- 4 Monitor the progress of the mirroring operation with the `vxtask list` command.

```
# vxtask list
TASKID PTID TYPE/STATE PCT PROGRESS
161 PARENT/R 0.00% 3/0(1) VXRECOVER dg01 dg
162 162 ATCOPY/R 04.77% 0/41945715/2000896 PLXATT home home-01 dg
```

## Booting from alternate boot disks

If the root disk is encapsulated and mirrored, you can use one of its mirrors to boot the system if the primary boot disk fails. This procedure differs between Sun SPARC systems and Sun x64 systems.

### Booting from an alternate (mirror) boot disk on Sun x64 systems

On a Sun x64 system, the alternate boot disk is added to the GRUB boot menu when a boot disk is mirrored. If one root disk fails, the system stays up and lets you replace the disk. No reboot is required to perform this maintenance with internal SAS controllers and other CRU-type drives that are hot swappable. Replace the disk, then rescan with the `vxdtl enable` command to discover the replacement.

Alternatively, the `bootpath` can be redefined in the EEPROM without changing the GRUB configuration.

See “[The boot process on x64 systems](#)” on page 136.

Console access and the ability to select from the GRUB menu is required for the following procedure. The system should not have rebooted because of plex failure, but may have rebooted for other reasons.

### To boot from an alternate boot disk on an x64 system

- 1 Select the "Alternate" GRUB menu entry:

```
title Solaris 10 11/06 s10x_u3wos_10 x64 <VxVM: Alternate Boot Disk>
    root (hd0,0,a)
    kernel /platform/i64pc/multiboot
    module /platform/i64pc/boot_archive.alt
```

- 2 After the system has booted, see the *Veritas Volume Manager Troubleshooting Guide* for information on replacing the failed drive.

### The boot process on x64 systems

From Update 1 of the Solaris 10 OS, x64 systems are configured to use the GRUB boot loader. The devices from which a system may be booted are defined in the GRUB configuration file, `/boot/grub/menu.lst`. From the GRUB menu, you can select from the available bootable partitions that are known to the system. By default, the system will boot from the device that is defined by the `bootpath` variable in the EEPROM.

### Defining root disk mirrors as bootable

After creating a root disk mirror, you can make it available for booting.

On Sun x64 systems, VxVM automatically creates a GRUB menu entry for the alternate boot disk when the boot disk is mirrored. During the booting process, select the alternate GRUB menu entry from the system console.

An alternate method is to change the 'default' GRUB menu setting in the `/boot/grub/menu.lst` file to select this entry automatically during the booting process.

### Booting from an alternate boot disk on Sun SPARC systems

If the root disk is encapsulated and mirrored, you can use one of its mirrors to boot the system if the primary boot disk fails.

On a Sun SPARC system, booting from an alternate boot disk requires that some EEPROM settings are changed.

See [“The boot process on SPARC systems”](#) on page 136.

### The boot process on SPARC systems

A Sun SPARC® system prompts for a boot command unless the `autoboot` flag has been set in the nonvolatile storage area used by the firmware. Machines with older PROMs have different prompts than that for the newer V2 and V3 versions. These



newer versions of PROM are also known as OpenBoot PROMs (OBP). The `boot` command syntax for the newer types of PROMs is:

```
ok boot [OBP names] [filename] [boot-flags]
```

The OBP names specify the OpenBoot PROM designations. For example, on Desktop SPARC systems, the designation `sbus/esp@0,800000/sd@3,0:a` indicates a SCSI disk (`sd`) at target 3, lun 0 on the SCSI bus, with the `esp` host bus adapter plugged into slot 0.

You can use Veritas Volume Manager boot disk alias names instead of OBP names. Example aliases are `vx-rootdisk` or `vx-disk01`. To list the available boot devices, use the `devalias` command at the OpenBoot prompt.

The filename argument is the name of a file that contains the kernel. The default is `/kernel/unix` in the `root` partition. If necessary, you can specify another program (such as `/stand/diag`) by specifying the `-a` flag. (Some versions of the firmware allow the default filename to be saved in the nonvolatile storage area of the system.)

---

**Warning:** Do not boot a system running VxVM with rootability enabled using all the defaults presented by the `-a` flag.

---

Boot flags are not interpreted by the `boot` program. The `boot` program passes all boot-flags to the file identified by filename.

See the `kadb` (1M) manual page.

See the `kernel` (1) manual page.

## Mirroring other file systems on the root disk

There may be other volumes on the root disk, such as volumes for `/home` or `/tmp` file systems. If necessary, these can be mirrored separately using the `vxassist` utility. For example, if you have a `/home` file system on a volume `homevol`, you can mirror it to `alternate_disk` using the command:

```
# vxassist mirror homevol alternate_disk
```

If you do not have space for a copy of some of these file systems on your alternate boot disk, you can mirror them to other disks. You can also span or stripe these other volumes across other disks attached to your system.

To list all volumes on your primary boot disk, use the command:

```
# vxprint -t -v -e'aslist.aslist.sd_disk="boot_disk"'
```

## Encapsulating SAN disks

A Solaris system may be booted from a SAN disk under the following conditions:

- For Solaris 9, the operating system must first be installed on an internal boot disk. The `ufsdump` and `ufsrestore` commands can then be used to create a bootable SAN disk. For more information, refer to the Sun document *Automating the Installation of an FC-Fabric SAN-Booted System* at [http://www.sun.com/bigadmin/features/articles/fc\\_fabric\\_san.html](http://www.sun.com/bigadmin/features/articles/fc_fabric_san.html).
- For Solaris 10, the operating system can also be installed directly onto a fabric disk in a SAN environment.

Veritas Volume Manager can encapsulate a bootable SAN disk provided that the disk is listed as being supported for this purpose in the Hardware Compatibility List (HCL) on the support site at <http://support.veritas.com>.

For some disk arrays, special hardware configuration may be required to allow a system to be booted from one of the LUNs in the array. Refer to the documentation supplied by the array vendor for more information. Having configured the disk array so that you can boot your system from it, you can proceed to encapsulate it using VxVM.

### To migrate from an internal boot disk to a SAN boot disk:

- 1 Verify that the HCL lists the target SAN disk as being supported for SAN booting.
- 2 Use `Add or initialize one or more disks` from the `vxdiskadm` main menu, or the VEA to add the target SAN disk to the boot disk group (aliased as `bootdg`).
- 3 Use `Mirror Volumes on a Disk` from the `vxdiskadm` main menu, or the VEA to create a mirror of the root disk on the target disk.
- 4 Boot from the mirror disk to verify that the system is still bootable.

Once you have booted the system from the SAN disk, you can mirror it to another SAN disk that has been added to the boot disk group.

If required, you can remove the plexes of the original boot disk by using the `vxplex` command. For example, the following command removes the plexes `rootvol-01`, `swapvol-01`, and `home-01` that are configured on the boot disk:

```
# vxplex -o rm dis rootvol-01 swapvol-01 home-01
```

## Administering an encapsulated boot disk

The `vxrootadm` command lets you grow an encapsulated boot disk or make a snapshot of it.

`vxrootadm` has the following format:

```
/etc/vx/bin/vxrootadm [-v] [-g dg] [-s srcdisk] ... keyword arg ...
```

The following are valid keyword and argument combinations:

- `/etc/vx/bin/vxrootadm -s srcdisk mksnap destdisk newdg`
- `/etc/vx/bin/vxrootadm -s srcdisk grow destdisk volumename=newsize ...`
- `/etc/vx/bin/vxrootadm grow continue`

See [“Growing an encapsulated boot disk”](#) on page 140.

`vxrootadm` includes the following options:

```
vxrootadm [-v ] [-D]
```

These are verbose and debug message options and are optional.

```
vxrootadm [-g dg]
```

The disk group argument is optional; however, it is only used with the `mksnap` keyword or during phase 1 of a grow operation.

## Creating a snapshot of an encapsulated boot disk

When you create a snapshot of an encapsulated boot disk, the `vxrootadm` command has the following format:

```
vxrootadm -s srcdisk [-g dg] mksnap destdisk newdg
```

The target disk for the snapshot must be as large (or bigger) than the source disk (boot disk). You must use a new disk group name to associate the target disk.

### To create a snapshot of an encapsulated boot disk

- ◆ With an encapsulated boot disk (in this example, `disk_0`) associated with the `bootdg` (`rootdg`), select a target disk (`disk_1`) and a new disk group name (`snapdg`). Enter the following command:

```
/etc/vx/bin/vxrootadm -s disk_0 -g rootdg mksnap disk_1 snapdg
```

A snapshot boot disk (`disk_1`) is created and associated with the new disk group name (`snapdg`).

See “[Booting from alternate boot disks](#)” on page 135.

### Growing an encapsulated boot disk

When you grow an encapsulated boot disk, the format of the `grow` keyword depends on whether the operation can be completed in one or more phases.

For single phase grow operations, that is, a grow operation for a non-booted root disk created as a mirror, a snapshot, or using the `mksnap` keyword, use the following format. Because this is not the currently booted root disk, all operations can be completed within a single phase without a reboot.

```
vxrootadm -s srcdisk [-g dg] grow destdisk volumename=newsize  
volumename=newsize ...
```

For multiple (four) phased grow operations, that is, a grow operation for the booted root disk, do the following:

- For phase 1, specify all the arguments, as in the single phase above.
- For the additional phases (phases 2-4), specify `vxrootadm grow continue`

The target disk for the grow operation must be of equal or greater size of the source disk (`boot disk`). The grow operation can be performed on the active boot disk or a snapshot boot disk.

### To grow an active encapsulated boot disk

- 1 To complete the grow operation on the active boot disk, will require three reboots to complete the grow operations for the selected volume (`rootvol`, `usrvol`, or `swapvol`).
- 2 With the encapsulated boot disk (`disk_0`) associated with the `bootdg` (`rootdg`), select a target disk (`disk_1`), and the volume to be grown (`rootvol` of size 60g). Enter the following the command.

```
/etc/vx/bin/vxrootadm -s disk_0 -g rootdg grow disk_1  
rootvol=80g
```

- The `vxrootadm` operation instructs the user when a reboot is required (with specific command needed), and how to continue the grow operation after the reboot is completed.
- When the grow operation is completed, the target disk will be the active boot disk, with the volume grown to the selected size, and the source boot disk will be removed from the boot disk group (`rootdg`).

### To grow a snapshot (not active) encapsulated boot disk

- 1 To complete the grow operation on the snapshot (not active) boot disk, no reboots are required to complete the grow operations for the selected volume (`rootvol`, `usrvol`, or `swapvol`).
- 2 With the snapshot encapsulated boot disk (`disk_1`) associated with the `snapdg` disk group, select a target disk (`disk_2`), and the volume to be grown (`rootvol` of size 60g). Enter the following command:

```
/etc/vx/bin/vxrootadm -s disk_1 -g snapdg grow disk_2  
rootvol=80g
```

When the grow operation is completed, the target disk volume will be grown to the indicated size, and the source disk will be removed from the disk group (`snapdg`).

See [“Booting from alternate boot disks”](#) on page 135.

## Unencapsulating the root disk

You can use the `vxunroot` utility to remove rootability support from a system. This makes `root`, `swap`, `home` and other file systems on the root disk directly accessible through disk partitions, instead of through volume devices.

The `vxunroot` utility also makes the necessary configuration changes to allow the system to boot without any dependency on VxVM.

Only the volumes that were present on the root disk when it was encapsulated can be unencapsulated using `vxunroot`. Before running `vxunroot`, evacuate all other volumes that were created on the root disk after it was encapsulated.

Do not remove the plexes on the root disk that correspond to the original disk partitions.

---

**Warning:** This procedure requires a reboot of the system.

---

**To remove rootability from a system**

- 1 Use the `vxplex` command to remove all the plexes of the volumes `rootvol`, `swapvol`, `usr`, `var`, `opt` and `home` on the disks other than the root disk.

For example, the following command removes the plexes `rootvol-02`, `swapvol-02`, and `home-02` that are configured on the boot disk mirror:

```
# vxplex -g bootdg -o rm dis rootvol-02 swapvol-02 home-02
```

- 2 Run the `vxunroot` utility:

```
# /etc/vx/bin/vxunroot
```

`vxunroot` does not perform any conversion to disk partitions if any plexes remain on other disks.

## Displaying disk information

Before you use a disk, you need to know if it has been initialized and placed under VxVM control. You also need to know if the disk is part of a disk group, because you cannot create volumes on a disk that is not part of a disk group. The `vxdisk list` command displays device names for all recognized disks, the disk names, the disk group names associated with each disk, and the status of each disk.

**To display information on all disks that are known to VxVM**

- ◆ Type the following command:

```
# vxdisk list
```

VxVM returns a display similar to the following:

DEVICE	TYPE	DISK	GROUP	STATUS
c0t0d0s2	auto:sliced	mydg04	mydg	online
c1t0d0s2	auto:sliced	mydg03	mydg	online
c1t1d0s2	auto:sliced	-	-	online invalid
enc0_2	auto:sliced	mydg02	mydg	online
enc0_3	auto:sliced	mydg05	mydg	online
sena0_0	auto:sliced	-	-	online
sena0_1	auto:sliced	-	-	online

The phrase `online invalid` in the `STATUS` line indicates that a disk has not yet been added to VxVM control. These disks may or may not have been initialized by VxVM previously. Disks that are listed as `online` are already under VxVM control.

### To display information about an individual disk

- ◆ Type the following command:

```
# vxdisk [-v] list diskname
```

The `-v` option causes the command to additionally list all tags and tag values that are defined for the disk. Without this option, no tags are displayed.

## Displaying disk information with vxdiskadm

Displaying disk information shows you which disks are initialized, to which disk groups they belong, and the disk status. The `list` command displays device names for all recognized disks, the disk names, the disk group names associated with each disk, and the status of each disk.

### To display disk information

- 1 Start the `vxdiskadm` program, and select `list` (List disk information) from the main menu.
- 2 At the following display, enter the address of the disk you want to see, or enter `all` for a list of all disks:

```
List disk information  
Menu: VolumeManager/Disk/ListDisk
```

```
VxVM INFO V-5-2-475 Use this menu operation to display a list of  
disks. You can also choose to list detailed information about  
the disk at a specific disk device address.
```

```
Enter disk device or "all" [<address>,all,q,?] (default: all)
```

- If you enter `all`, VxVM displays the device name, disk name, group, and status.
- If you enter the address of the device for which you want information, complete disk information (including the device name, the type of disk, and information about the public and private areas of the disk) is displayed.

Once you have examined this information, press Return to return to the main menu.

## Dynamic LUN expansion

Many modern disk arrays allow existing LUNs to be resized. The following form of the `vxdisk` command can be used to make VxVM aware of the new size of a LUN that has been resized:

```
# vxdisk [-f] [-g diskgroup] resize {accessname|medianame} \  
    [length=value]
```

The device must have a SCSI interface that is presented by a smart switch, smart array or RAID controller. Following a resize operation to increase the length that is defined for a device, additional disk space on the device is available for allocation. You can optionally specify the new size by using the `length` attribute.

If a disk media name rather than a disk access name is specified, the disk group must either be specified using the `-g` option or the default disk group will be used. If the default disk group has not been set up, an error message will be generated.

This facility is provided to support dynamic LUN expansion by updating disk headers and other VxVM structures to match a new LUN size. It does not resize the LUN itself.

Any volumes on the device should only be grown after the LUN itself has first been grown.

Resizing should only be performed on LUNs that preserve data. Consult the array documentation to verify that data preservation is supported and has been qualified. The operation also requires that only storage at the end of the LUN is affected. Data at the beginning of the LUN must not be altered. No attempt is made to verify the validity of pre-existing data on the LUN. The operation should be performed on the host where the disk group is imported (or on the master node for a cluster-shared disk group).

Resizing of LUNs that are not part of a disk group is not supported. It is not possible to resize LUNs that are in the boot disk group (aliased as `bootdg`), in a deported disk group, or that are offline, uninitialized, being reinitialized, or in an error state.

---

**Warning:** Do not perform this operation when replacing a physical disk with a disk of a different size as data is not preserved.

---

Before shrinking a LUN, first shrink any volumes on the LUN or more those volumes off the LUN. Then, resize the device using `vxdisk resize`. Finally, resize the LUN itself using the storage array's management utilities. By default, the resize fails if any subdisks would be disabled as a result of their being removed in whole or in part during a shrink operation.



If the device that is being resized has the only valid configuration copy for a disk group, the `-f` option may be specified to forcibly resize the device.

Resizing a device that contains the only valid configuration copy for a disk group can result in data loss if a system crash occurs during the resize.

Resizing a virtual disk device is a non-transactional operation outside the control of VxVM. This means that the `resize` command may have to be re-issued following a system crash. In addition, a system crash may leave the private region on the device in an unusable state. If this occurs, the disk must be reinitialized, reattached to the disk group, and its data resynchronized or recovered from a backup.

## Removing disks

You must disable a disk group before you can remove the last disk in that group.

See [“Disabling a disk group”](#) on page 269.

As an alternative to disabling the disk group, you can destroy the disk group.

See [“Destroying a disk group”](#) on page 269.

You can remove a disk from a system and move it to another system if the disk is failing or has failed.

### To remove a disk

- 1 Stop all activity by applications to volumes that are configured on the disk that is to be removed. Unmount file systems and shut down databases that are configured on the volumes.
- 2 Use the following command to stop the volumes:  

```
# vxvol [-g diskgroup] stop vol1 vol2 ...
```
- 3 Move the volumes to other disks or back up the volumes. To move a volume, use `vxdiskadm` to mirror the volume on one or more disks, then remove the original copy of the volume. If the volumes are no longer needed, they can be removed instead of moved.
- 4 Check that any data on the disk has either been moved to other disks or is no longer needed.
- 5 Select `Remove a disk` from the `vxdiskadm` main menu.
- 6 At the following prompt, enter the disk name of the disk to be removed:

```
Enter disk name [<disk>,list,q,?] mydg01
```

- 7 If there are any volumes on the disk, VxVM asks you whether they should be evacuated from the disk. If you wish to keep the volumes, answer `y`. Otherwise, answer `n`.

- 8 At the following verification prompt, press Return to continue:

```
VxVM NOTICE V-5-2-284 Requested operation is to remove disk  
mydg01 from group mydg.
```

```
Continue with operation? [y,n,q,?] (default: y)
```

The `vxdiskadm` utility removes the disk from the disk group and displays the following success message:

```
VxVM INFO V-5-2-268 Removal of disk mydg01 is complete.
```

You can now remove the disk or leave it on your system as a replacement.

- 9 At the following prompt, indicate whether you want to remove other disks (`y`) or return to the `vxdiskadm` main menu (`n`):

```
Remove another disk? [y,n,q,?] (default: n)
```

## Removing a disk with subdisks

You can remove a disk on which some subdisks are defined. For example, you can consolidate all the volumes onto one disk. If you use the `vxdiskadm` program to remove a disk, you can choose to move volumes off that disk.

Some subdisks are not movable. A subdisk may not be movable for one of the following reasons:

- There is not enough space on the remaining disks in the subdisks disk group.
- Plexes or striped subdisks cannot be allocated on different disks from existing plexes or striped subdisks in the volume.

If the `vxdiskadm` program cannot move some subdisks, remove some plexes from some disks to free more space before proceeding with the disk removal operation.

See [“Removing a volume”](#) on page 372.

See [“Taking plexes offline”](#) on page 295.

### To remove a disk with subdisks

- 1 Run the `vxdiskadm` program and select `Remove` a disk from the main menu.

If the disk is used by some subdisks, the following message is displayed:

```
VxVM ERROR V-5-2-369 The following volumes currently use part of
disk mydg02:
```

```
home usrvol
```

```
Volumes must be moved from mydg02 before it can be removed.
```

```
Move volumes to other disks? [y,n,q,?] (default: n)
```

- 2 Choose `y` to move all subdisks off the disk, if possible.

## Removing a disk with no subdisks

### To remove a disk that contains no subdisks from its disk group

- ◆ Run the `vxdiskadm` program and select `Remove` a disk from the main menu, and respond to the prompts as shown in this example to remove `mydg02`:

```
Enter disk name [<disk>,list,q,?] mydg02
```

```
VxVM NOTICE V-5-2-284 Requested operation is to remove disk mydg02 from
group mydg.
```

```
Continue with operation? [y,n,q,?] (default: y) y
```

```
VxVM INFO V-5-2-268 Removal of disk mydg02 is complete.
```

```
Clobber disk headers? [y,n,q,?] (default: n) y
```

Enter `y` to remove the disk completely from VxVM control. If you do not want to remove the disk completely from VxVM control, enter `n`.

## Removing a disk from VxVM control

After removing a disk from a disk group, you can permanently remove it from Veritas Volume Manager control.

---

**Warning:** The `vxdiskunsetup` command removes a disk from Veritas Volume Manager control by erasing the VxVM metadata on the disk. To prevent data loss, any data on the disk should first be evacuated from the disk. The `vxdiskunsetup` command should only be used by a system administrator who is trained and knowledgeable about Veritas Volume Manager.

---

**To remove a disk from VxVM control**

- ◆ Type the following command:

```
# /usr/lib/vxvm/bin/vxdiskunsetup c#t#d#
```

## Removing and replacing disks

A replacement disk should have the same disk geometry as the disk that failed. That is, the replacement disk should have the same bytes per sector, sectors per track, tracks per cylinder and sectors per cylinder, same number of cylinders, and the same number of accessible cylinders.

You can use the `prtvtoc` command to obtain disk information.

---

**Note:** You may need to run commands that are specific to the operating system or disk array before removing a physical disk.

---

The removal and replacement of a disk in a Sun StorEdge™ A5x00 or similar type of array, requires a different procedure.

See [“Removing and replacing a disk in a Sun StorEdge A5x00 disk array”](#) on page 154.

If failures are starting to occur on a disk, but the disk has not yet failed completely, you can replace the disk. This involves detaching the failed or failing disk from its disk group, followed by replacing the failed or failing disk with a new one. Replacing the disk can be postponed until a later date if necessary.

If removing a disk causes a volume to be disabled, you can restart the volume so that you can restore its data from a backup.

See the *Veritas Volume Manager Troubleshooting Guide*.

### To replace a disk

- 1 **Select** Remove a disk for replacement from the `vxdiskadm` main menu.
- 2 At the following prompt, enter the name of the disk to be replaced (or enter `list` for a list of disks):

```
Enter disk name [<disk>,list,q,?] mydg02
```

- 3 When you select a disk to remove for replacement, all volumes that are affected by the operation are displayed, for example:

```
VxVM NOTICE V-5-2-371 The following volumes will lose mirrors  
as a result of this operation:
```

```
home src
```

```
No data on these volumes will be lost.
```

```
The following volumes are in use, and will be disabled as a  
result of this operation:
```

```
mkting
```

```
Any applications using these volumes will fail future  
accesses. These volumes will require restoration from backup.
```

```
Are you sure you want do this? [y,n,q,?] (default: n)
```

To remove the disk, causing the named volumes to be disabled and data to be lost when the disk is replaced, enter `y` or press Return.

To abandon removal of the disk, and back up or move the data associated with the volumes that would otherwise be disabled, enter `n` or `q` and press Return.

For example, to move the volume `mkting` to a disk other than `mydg02`, use the following command.

The `!` character is a special character in some shells. The following example shows how to escape it in a bash shell.

```
# vxassist move mkting \!mydg02
```

After backing up or moving the data in the volumes, start again from step 1.

- 4 At the following prompt, either select the device name of the replacement disk (from the list provided), press Return to choose the default disk, or enter `none` if you are going to replace the physical disk:

```
The following devices are available as replacements:  
c0t1d0
```

```
You can choose one of these disks now, to replace mydg02.  
Select none if you do not wish to select a replacement disk.
```

```
Choose a device, or select none  
[<device>,none,q,?] (default: c0t1d0)
```

Do not choose the old disk drive as a replacement even though it appears in the selection list. If necessary, you can choose to initialize a new disk.

You can enter `none` if you intend to replace the physical disk.

See [“Replacing a failed or removed disk”](#) on page 152.

- 5 If you chose to replace the disk in step 4, press Return at the following prompt to confirm this:

```
VxVM NOTICE V-5-2-285 Requested operation is to remove mydg02  
from group mydg. The removed disk will be replaced with disk device  
c0t1d0. Continue with operation? [y,n,q,?] (default: y)
```

`vxdiskadm` displays the following messages to indicate that the original disk is being removed:

```
VxVM NOTICE V-5-2-265 Removal of disk mydg02 completed  
successfully.  
VxVM NOTICE V-5-2-260 Proceeding to replace mydg02 with device  
c0t1d0.
```

- 6** If the disk was previously an encapsulated root disk, `vxdiskadm` displays the following message. Enter `y` to confirm that you want to reinitialize the disk:

```
The disk clt0d0 was a previously encapsulated root disk. Due
to the disk layout that results from root disk encapsulation,
the preferred action is to reinitialize and reorganize this
disk. However, if you have any non-redundant data on this disk
you should not reorganize this disk, as the data will be lost.
Reorganize the disk? [y,n,q,?] (default: y) y
```

---

**Warning:** It is recommended that you do not enter `n` at this prompt. This results in an invalid `vTOC` that makes the disk unbootable.

---

Entering `y` at the prompt destroys any data that is on the disk. Ensure that you have at least one valid copy of the data on other disks before proceeding.

- 7** You can now choose whether the disk is to be formatted as a CDS disk that is portable between different operating systems, or as a non-portable sliced or simple disk:

```
Enter the desired format [cdsdisk,sliced,simple,q,?]
(default: cdsdisk)
```

Enter the format that is appropriate for your needs. In most cases, this is the default format, `cdsdisk`.

- 8** At the following prompt, `vxdiskadm` asks if you want to use the default private region size of 65536 blocks (32 MB). Press Return to confirm that you want to use the default value, or enter a different value. (The maximum value that you can specify is 524288 blocks.)

```
Enter desired private region length [<privlen>,q,?]
(default: 65536)
```

- 9 If one of more mirror plexes were moved from the disk, you are now prompted whether FastResync should be used to resynchronize the plexes:

```
Use FMR for plex resync? [y,n,q,?] (default: n) y
vxdiskadm displays the following success message:
VxVM NOTICE V-5-2-158 Disk replacement completed successfully.
```

- 10 At the following prompt, indicate whether you want to remove another disk (y) or return to the vxdiskadm main menu (n):

```
Remove another disk? [y,n,q,?] (default: n)
```

It is possible to move hot-relocate subdisks back to a replacement disk.

See [“Configuring hot-relocation to use only spare disks”](#) on page 480.

## Replacing a failed or removed disk

The following procedure describes how to replace a failed or removed disk.

A different procedure is required to remove and replace a disk in a Sun StorEdge A5x00 or similar type of array.

See [“Removing and replacing a disk in a Sun StorEdge A5x00 disk array”](#) on page 154.

### To specify a disk that has replaced a failed or removed disk

- 1 Select `Replace a failed or removed disk` from the vxdiskadm main menu.
- 2 At the following prompt, enter the name of the disk to be replaced (or enter list for a list of disks):

```
Select a removed or failed disk [<disk>,list,q,?] mydg02
```

- 3 The vxdiskadm program displays the device names of the disk devices available for use as replacement disks. Your system may use a device name that differs from the examples. Enter the device name of the disk or press Return to select the default device:

```
The following devices are available as replacements:
c0t1d0 c1t1d0
```

You can choose one of these disks to replace mydg02.  
Choose "none" to initialize another disk to replace mydg02.

```
Choose a device, or select "none"
[<device>,none,q,?] (default: c0t1d0)
```



- 4 Depending on whether the replacement disk was previously initialized, perform the appropriate step from the following:
- If the disk has not previously been initialized, press Return at the following prompt to replace the disk:

```
VxVM INFO V-5-2-378 The requested operation is to initialize
disk device c0t1d0 and to then use that device to
replace the removed or failed disk mydg02 in disk group mydg.
Continue with operation? [y,n,q,?] (default: y)
```

- If the disk has already been initialized, press Return at the following prompt to replace the disk:

```
VxVM INFO V-5-2-382 The requested operation is to use the
initialized device c0t1d0 to replace the removed or
failed disk mydg02 in disk group mydg.
Continue with operation? [y,n,q,?] (default: y)
```

- If the disk was previously an encapsulated root disk, `vxdiskadm` displays the following message. Enter `y` to confirm that you want to reinitialize the disk:

```
VxVM INFO V-5-2-876 The disk c0t1d0 was a previously
encapsulated root disk. Due to the disk layout that results
from root disk encapsulation, the preferred action is to
reinitialize and reorganize this disk. However, if you have
any non-redundant data on this disk you should not reorganize
this disk, as the data will be lost.
Reorganize the disk? [y,n,q,?] (default: y) y
```

---

**Warning:** It is recommended that you do not enter `n` at this prompt. This can result in an invalid VTOC that makes the disk unbootable.

---

Entering `y` at the prompt destroys any data that is on the disk. Ensure that you have at least one valid copy of the data on other disks before proceeding.

- 5 You can now choose whether the disk is to be formatted as a CDS disk that is portable between different operating systems, or as a non-portable sliced or simple disk:

```
Enter the desired format [cdsdisk,sliced,simple,q,?]  
(default: cdsdisk)
```

Enter the format that is appropriate for your needs. In most cases, this is the default format, `cdsdisk`.

- 6 At the following prompt, `vxdiskadm` asks if you want to use the default private region size of 65536 blocks (32 MB). Press Return to confirm that you want to use the default value, or enter a different value. (The maximum value that you can specify is 524288 blocks.)

```
Enter desired private region length [<privlen>,q,?]  
(default: 65536)
```

- 7 The `vxdiskadm` program then proceeds to replace the disk, and returns the following message on success:

```
VxVM NOTICE V-5-2-158 Disk replacement completed successfully.
```

At the following prompt, indicate whether you want to replace another disk (y) or return to the `vxdiskadm` main menu (n):

```
Replace another disk? [y,n,q,?] (default: n)
```

## Removing and replacing a disk in a Sun StorEdge A5x00 disk array

---

**Note:** The following procedure is suitable for use with any array that is administered by using the Solaris `luxadm` command.

---

### To replace a disk in a Sun StorEdge A5x00 disk array

- 1 Run the `vxdiskadm` command, and select `Remove` a disk for replacement from the main men. Enter `none` when prompted to name a replacement disk.
- 2 Use the following command to remove the disk from VxVM:

```
# vxdisk rm daname
```

where *daname* is the disk access name of the device (for example, `c1t5d0s2`).

- 3 Use the Solaris `luxadm` command to obtain the array name and slot number of the disk, and then use these values with `luxadm` to remove the disk:

```
# luxadm disp /dev/rdisk/daname
# luxadm remove_device array_name,slot_number
```

Follow the `luxadm` prompts, and pull out the disk when instructed.

- 4 Run the following `luxadm` command when you are ready to insert the replacement disk:

```
# luxadm insert_device array_name,slot_number
```

Follow the `luxadm` prompts, and insert the replacement disk when instructed.

- 5 Run the following command to scan for the new disk and update the system:

```
# vxdiskconfig
```

- 6 Run the `vxdiskadm` command, select `Replace` a failed or removed disk from the main menu, and follow the instructions.

See “[Replacing a failed or removed disk](#)” on page 152.

## Enabling a disk

If you move a disk from one system to another during normal system operation, VxVM does not recognize the disk automatically. The enable disk task enables VxVM to identify the disk and to determine if this disk is part of a disk group. Also, this task re-enables access to a disk that was disabled by either the disk group deport task or the disk device disable (offline) task.

### To enable a disk

- 1 Select `Enable (online)` a disk device from the `vxdiskadm` main menu.
- 2 At the following prompt, enter the device name of the disk to be enabled (or enter `list` for a list of devices):

```
Select a disk device to enable [<address>,list,q,?]
```

```
c0t2d0s2
```

`vxdiskadm` enables the specified device.

- 3 At the following prompt, indicate whether you want to enable another device (`y`) or return to the `vxdiskadm` main menu (`n`):

```
Enable another device? [y,n,q,?] (default: n)
```

## Taking a disk offline

There are instances when you must take a disk offline. If a disk is corrupted, you must disable the disk before removing it. You must also disable a disk before moving the physical disk device to another location to be connected to another system.

---

**Warning:** Taking a disk offline is only useful on systems that support hot-swap removal and insertion of disks. If a system does not support hot-swap removal and insertion of disks, you must shut down the system.

---

### To take a disk offline

- 1 Select `Disable (offline)` a disk device from the `vxdiskadm` main menu.
- 2 At the following prompt, enter the address of the disk you want to disable:

```
Select a disk device to disable [<address>,list,q,?]  
c0t2d0s2
```

The `vxdiskadm` program disables the specified disk.

- 3 At the following prompt, indicate whether you want to disable another device (`y`) or return to the `vxdiskadm` main menu (`n`):

```
Disable another device? [y,n,q,?] (default: n)
```

## Renaming a disk

If you do not specify a VM disk name, `VxVM` gives the disk a default name when you add the disk to `VxVM` control. The VM disk name is used by `VxVM` to identify the location of the disk or the disk type.

### To rename a disk

- ◆ Type the following command:

```
# vxedit [-g diskgroup] rename old_diskname new_diskname
```

By default, VxVM names subdisk objects after the VM disk on which they are located. Renaming a VM disk does not automatically rename the subdisks on that disk.

For example, you might want to rename `diskmydg03`, as shown in the following output from `vxdisk list`, to `mydg02`:

```
# vxdisk list
DEVICE          TYPE          DISK          GROUP         STATUS
c0t0d0s2       auto:sliced   mydg01       mydg          online
c1t0d0s2       auto:sliced   mydg03       mydg          online
c1t1d0s2       auto:sliced   -            -            online
```

You would use the following command to rename the disk.

```
# vxedit -g mydg rename mydg03 mydg02
```

To confirm that the name change took place, use the `vxdisk list` command again:

```
# vxdisk list
DEVICE          TYPE          DISK          GROUP         STATUS
c0t0d0s2       auto:sliced   mydg01       mydg          online
c1t0d0s2       auto:sliced   mydg02       mydg          online
c1t1d0s2       auto:sliced   -            -            online
```

## Reserving disks

By default, the `vxassist` command allocates space from any disk that has free space. You can reserve a set of disks for special purposes, such as to avoid general use of a particularly slow or a particularly fast disk.

### To reserve a disk

- ◆ Type the following command:

```
# vxedit [-g diskgroup] set reserve=on diskname
```

After you enter this command, the `vxassist` program does not allocate space from the selected disk unless that disk is specifically mentioned on the `vxassist` command line. For example, if `mydg03` is reserved, use the following command:

```
# vxassist [-g diskgroup] make vol03 20m mydg03
```

The `vxassist` command overrides the reservation and creates a 20 megabyte volume on `mydg03`. However, this command does not use `mydg03`, even if there is no free space on any other disk:

```
# vxassist -g mydg make vol04 20m
```

### To turn off reservation of a disk

- ◆ Type the following command:

```
# vxedit [-g diskgroup] set reserve=off diskname
```

See the `vxedit(1M)` manual page.

## Changing host LUN configurations online

System administrators and storage administrators may need to modify the set of LUNs provisioned to server. You can change the LUN configuration dynamically, without performing a reconfiguration reboot on the host.

Dynamic LUN reconfigurations require array configuration commands, operating system commands, and Veritas Volume manager commands. To complete the operations correctly, you must issue the commands in the proper sequence on the host.

The operations are as follows:

- Dynamic LUN removal from an existing target ID  
See [“Removing LUNs dynamically from an existing target ID”](#) on page 159.
- Dynamic new LUN addition to a new target ID  
See [“Adding new LUNs dynamically to a new target ID”](#) on page 160.

## Removing LUNs dynamically from an existing target ID

In this case, a group of LUNs is unmapped from the host HBA ports and an operating system device scan is issued. The device scan recognizes the LUNs and adds them to DMP control. To add subsequent LUNs seamlessly, perform additional steps to cleanup the operating system device tree.

The high-level procedure and the VxVM commands are generic. However, the operating system commands may vary depending on the Solaris version. For example, the following procedure uses Solaris 10 with the Leadville stack.

See “[Changing host LUN configurations online](#)” on page 158.

### To remove LUNs dynamically from an existing target ID

- 1 Identify which LUNs to remove from the host. Do one of the following:
  - Use Storage Array Management to identify the Array Volume ID (AVID) for the LUNs.
  - If the array does not report the AVID, use the LUN index.

- 2 Evacuate the data from the LUNs from the Volume Manager.

See the `vxevac(1M)` online manual page.

- 3 Remove the LUNs from the disk group. Do one of the following:
  - If the data has been evacuated, enter the following command:

```
# vxdbg -g diskgroup rmdisk da-name
```

- If the data has not been evacuated and the LUN is part of a subdisk or diskgroup, enter the following command. If the disk is part of a shared disk group, you must use the `-k` option to force the removal.

```
# vxdbg -g diskgroup -k rmdisk da-name
```

- 4 Using the AVID or LUN index, use Storage Array Management to unmap or unmask the LUNs you identified in step 1.

- 5 Remove the LUNs from the `vdisk` list. Enter the following command on all nodes in a cluster:

```
# vxdisk rm da-name
```

This is a required step. If you do not perform this step, the DMP device tree shows ghost paths.

- 6 Clean up the Solaris SCSI device tree for the devices that you removed in step 5.

See “[Cleaning up the operating system device tree after removing LUNs](#)” on page 162.

This is a required step. You must clean up the operating system SCSI device tree to release the SCSI target ID for reuse if a new LUN is added to the host later.

- 7 Scan the operating system device tree.

See “[Scanning an operating system device tree after adding or removing LUNs](#)” on page 162.

- 8 Use Volume Manager to perform a device scan. You must perform this operation on all nodes in a cluster. Enter one of the following commands:

- # `vxdctl enable`

- # `vxdisk scandisks`

- 9 Verify that the LUNs were removed cleanly by answering the following questions:

- Is the device tree clean?

Verify that the operating system metanodes are removed from the `/dev` directory.

- Were all the appropriate LUNs removed?

Use the DMP disk reporting tools such as the `vxdisk list` command output to determine if the LUNs have been cleaned up successfully.

- Is the `vxdisk list` output correct?

Verify that the `vxdisk list` output shows the correct number of paths and does not include any ghost disks.

If the answer to any of these questions is "No," return to step 4 and perform the required steps.

If the answer to all of the questions is "Yes," the LUN remove operation is successful.

## Adding new LUNs dynamically to a new target ID

In this case, a new group of LUNs is mapped to the host via multiple HBA ports. An operating system device scan is issued for the LUNs to be recognized and added to DMP control.



The high-level procedure and the VxVM commands are generic. However, the operating system commands may vary depending on the Solaris version. For example, the following procedure uses Solaris 10 with the Leadville stack.

#### To add new LUNs dynamically to a new target ID

- 1 Identify which LUNs to add to the host. Do one of the following:
  - Use Storage Array Management to identify the Array Volume ID (AVID) for the LUNs.
  - If the array does not report the AVID, use the LUN index.
- 2 Map/mask the LUNs to the new target IDs on multiple hosts.
- 3 Scan the operating system device.

See [“Scanning an operating system device tree after adding or removing LUNs”](#) on page 162.

Repeat step 1 and step 2 until you see that all the LUNs have been added.

- 4 Use Volume Manager to perform a device scan. You must perform this operation on all nodes in a cluster. Enter one of the following commands:

- `# vxctl enable`
- `# vxdisk scandisks`

- 5 Verify that the LUNs were added correctly by answering the following questions:

- Do the newly provisioned LUNs appear in the `vxdisk list` output?
- Are there multiple paths for each LUN?

If the answer to any of these questions is "No," return to step 1 and begin the procedure again.

If the answer to all of the questions is "Yes," the LUNs have been successfully added. You can now add the LUNs to a disk group, create new volumes, or grow existing volumes.

## About detecting target ID reuse if the operating system device tree is not cleaned up

If you try to reprovision a LUN or set of LUNs whose previously-valid operating system device entries are not cleaned up, the following messages are displayed. Also, DMP reconfiguration during the DMP device scan and DMP reconfiguration are temporarily inhibited.

See “Cleaning up the operating system device tree after removing LUNs” on page 162.

```
VxVM vxdisk ERROR V-5-1-14519 Data Corruption Protection Activated  
- User Corrective Action Needed
```

```
VxVM vxdisk INFO V-5-1-14521 To recover, first ensure that the OS  
device tree is up to date (requires OS specific commands).
```

```
VxVM vxdisk INFO V-5-1-14520 Then, execute 'vxdisk rm' on the  
following devices before reinitiating device discovery. <DA names>
```

The message above indicates that a new LUN is trying to reuse the target ID of an older LUN. The device entries have not been cleaned, so the new LUN cannot use the target ID. Until the operating system device tree is cleaned up, DMP prevents this operation.

## Scanning an operating system device tree after adding or removing LUNs

After you add or remove LUNs, scan the operating system device tree to verify that the operation completed successfully.

The operating system commands may vary, depending on the Solaris version. The following procedure uses Solaris 10 with the Leadville stack.

### To scan an operating system device tree after adding or removing LUNs

- 1 Enter the following command:

```
# cfgadm -c configure c2
```

where `c2` is the controller ID 2.

- 2 Enter the following command:

```
# devfsadm -Cv
```

## Cleaning up the operating system device tree after removing LUNs

After you remove LUNs, you must clean up the operating system device tree. The operating system commands may vary, depending on the Solaris version. The following procedure uses Solaris 10 with the Leadville stack. If any of these steps do not produce the desired result, contact Sun support.

## To clean up the operating system device tree after removing LUNs

- 1 Run the `format` command. In the command output, a device that has been removed includes the text `<drive not available>`.

```
413. c3t5006048ACAFE4A7Cd252 <drive not available>
/pci@1d,700000/SUNW,q1c@1,1/fp@0,0/ssd@w5006048acafe4a7c,fc
```

- 2 Use Storage Array Management or the command line to unmap the LUNs. After they are unmapped, Solaris indicates the devices are either `unusable` or `failing`.

```
# cfgadm -al -o show_SCSI_LUN | grep -I unusable
c2::5006048acafe4a73,256 disk connected configured unusable
c3::5006048acafe4a7c,255 disk connected configured unusable
# cfgadm -al -o show_SCSI_LUN | grep -I failing
c2::5006048acafe4a73,71 disk connected configured failing
c3::5006048acafe4a7c,252 disk connected configured failing
```

See “[Changing host LUN configurations online](#)” on page 158.

- 3 If the output indicates the LUNs are `failing`, you must force an LIP on the HBA.

```
# luxadm -e forcelp /devices/pci@1d,700000/SUNW,q1c@1,1/fp@0,0:devctl
```

This operation probes the targets again, so that output indicates the devices are `unstable`. To remove a device from the operating system device tree, it must be `unstable`.

- 4 Remove the device from the `dfgadm` database. On the HBA, enter the following commands:

```
# cfgadm -c unconfigure -o unusable_SCSI_LUN c2::5006048acafe4a73
# cfgadm -c unconfigure -o unusable_SCSI_LUN c3::5006048acafe4a7c
```

- 5 To verify that the LUNs have been removed, repeat step 2.
- 6 Clean up the device tree. The following command removes the `/dev/dsk` links to `/devices`.

```
# devfsadm -Cv
```



# Administering Dynamic Multipathing

This chapter includes the following topics:

- [How DMP works](#)
- [Disabling multipathing and making devices invisible to VxVM](#)
- [Enabling multipathing and making devices visible to VxVM](#)
- [Enabling and disabling I/O for controllers and storage processors](#)
- [Displaying DMP database information](#)
- [Displaying the paths to a disk](#)
- [Setting customized names for DMP nodes](#)
- [DMP coexistence with native multipathing](#)
- [Administering DMP using vxdkpadm](#)

## How DMP works

The Dynamic Multipathing (DMP) feature of Veritas Volume Manager (VxVM) provides greater availability, reliability and performance by using path failover and load balancing. This feature is available for multiported disk arrays from various vendors.

Multiported disk arrays can be connected to host systems through multiple paths. To detect the various paths to a disk, DMP uses a mechanism that is specific to each supported array type. DMP can also differentiate between different enclosures of a supported array type that are connected to the same host system.

See “[Discovering and configuring newly added disk devices](#)” on page 87.

The multipathing policy used by DMP depends on the characteristics of the disk array.

DMP supports the following standard array types:

Active/Active (A/A)	Allows several paths to be used concurrently for I/O. Such arrays allow DMP to provide greater I/O throughput by balancing the I/O load uniformly across the multiple paths to the LUNs. In the event that one path fails, DMP automatically routes I/O over the other available paths.
Asymmetric Active/Active (A/A-A)	A/A-A or Asymmetric Active/Active arrays can be accessed through secondary storage paths with little performance degradation. Usually an A/A-A array behaves like an A/P array rather than an A/A array. However, during failover, an A/A-A array behaves like an A/A array.
Active/Passive (A/P)	<p>Allows access to its LUNs (logical units; real disks or virtual disks created using hardware) via the primary (active) path on a single controller (also known as an access port or a storage processor) during normal operation.</p> <p>In implicit failover mode (or autotrespass mode), an A/P array automatically fails over by scheduling I/O to the secondary (passive) path on a separate controller if the primary path fails. This passive port is not used for I/O until the active port fails. In A/P arrays, path failover can occur for a single LUN if I/O fails on the primary path.</p>
Active/Passive in explicit failover mode or non-autotrespass mode (A/P-F)	The appropriate command must be issued to the array to make the LUNs fail over to the secondary path.

Active/Passive with LUN group failover (A/P-G)	For Active/Passive arrays with LUN group failover (A/PG arrays), a group of LUNs that are connected through a controller is treated as a single failover entity. Unlike A/P arrays, failover occurs at the controller level, and not for individual LUNs. The primary and secondary controller are each connected to a separate group of LUNs. If a single LUN in the primary controller's LUN group fails, all LUNs in that group fail over to the secondary controller.
Concurrent Active/Passive (A/P-C)	Variants of the A/P, AP/F and A/PG array types that support concurrent I/O and load balancing by having multiple primary paths into a controller. This functionality is provided by a controller with multiple ports, or by the insertion of a SAN hub or switch between an array and a controller. Failover to the secondary (passive) path occurs only if all the active primary paths fail.
Concurrent Active/Passive in explicit failover mode or non-autotrespass mode (A/PF-C)	
Concurrent Active/Passive with LUN group failover (A/PG-C)	

An array support library (ASL) may define array types to DMP in addition to the standard types for the arrays that it supports.

VxVM uses DMP metanodes (DMP nodes) to access disk devices connected to the system. For each disk in a supported array, DMP maps one node to the set of paths that are connected to the disk. Additionally, DMP associates the appropriate multipathing policy for the disk array with the node. For disks in an unsupported array, DMP maps a separate node to each path that is connected to a disk. The raw and block devices for the nodes are created in the directories `/dev/vx/rdmp` and `/dev/vx/dmp` respectively.

Figure 4-1 shows how DMP sets up a node for a disk in a supported disk array.

**Figure 4-1** How DMP represents multiple physical paths to a disk as one node

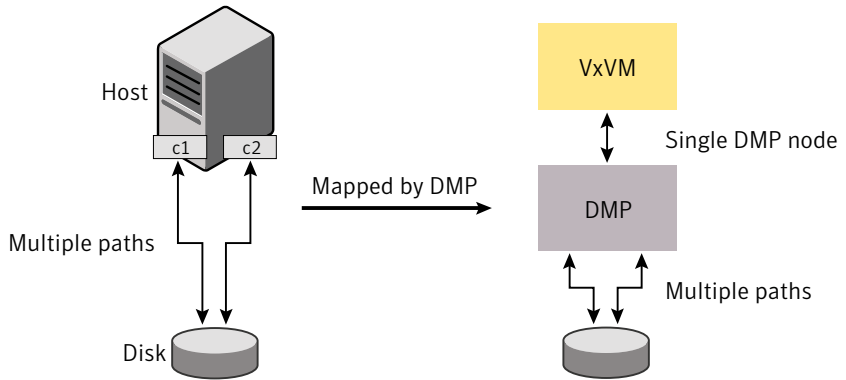

VxVM implements a disk device naming scheme that allows you to recognize to which array a disk belongs.

[Figure 4-2](#) shows an example where two paths, `c1t99d0` and `c2t99d0`, exist to a single disk in the enclosure, but VxVM uses the single DMP node, `enc0_0`, to access it.

**Figure 4-2** Example of multipathing for a disk enclosure in a SAN environment

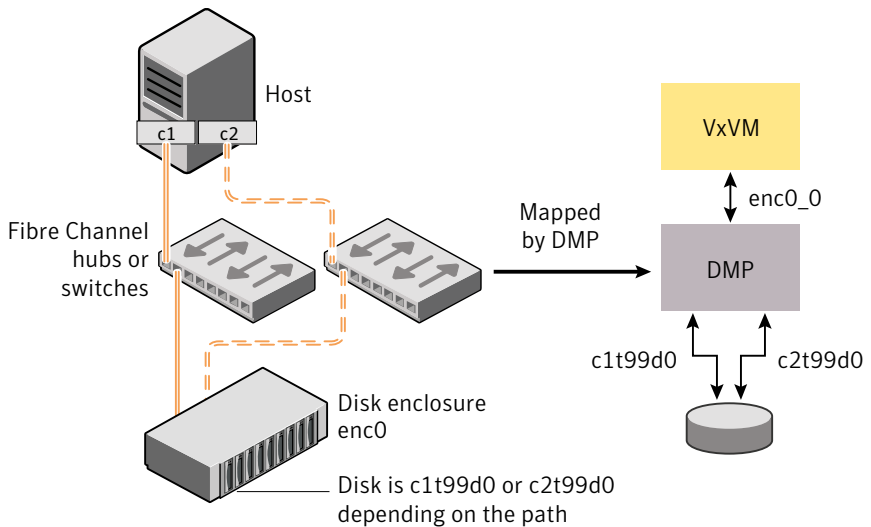

See [“Enclosure-based naming”](#) on page 27.

See [“Changing the disk-naming scheme”](#) on page 107.

See [“Discovering and configuring newly added disk devices”](#) on page 87.



## How DMP monitors I/O on paths

In older releases of VxVM, DMP had one kernel daemon (`errord`) that performed error processing, and another (`restored`) that performed path restoration activities.

From release 5.0, DMP maintains a pool of kernel threads that are used to perform such tasks as error processing, path restoration, statistics collection, and SCSI request callbacks. The `vxddmpadm stat` command can be used to provide information about the threads. The names `errord` and `restored` have been retained for backward compatibility.

One kernel thread responds to I/O failures on a path by initiating a probe of the host bus adapter (HBA) that corresponds to the path. Another thread then takes the appropriate action according to the response from the HBA. The action taken can be to retry the I/O request on the path, or to fail the path and reschedule the I/O on an alternate path.

The restore kernel thread is woken periodically (typically every 5 minutes) to check the health of the paths, and to resume I/O on paths that have been restored. As some paths may suffer from intermittent failure, I/O is only resumed on a path if has remained healthy for a given period of time (by default, 5 minutes). DMP can be configured with different policies for checking the paths.

See [“Configuring DMP path restoration policies”](#) on page 214.

The statistics-gathering thread records the start and end time of each I/O request, and the number of I/O failures and retries on each path. DMP can be configured to use this information to prevent the SCSI driver being flooded by I/O requests. This feature is known as I/O throttling.

If an I/O request relates to a mirrored volume, VxVM specifies the FAILFAST flag. In such cases, DMP does not retry failed I/O requests on the path, and instead marks the disks on that path as having failed.

See [“Path failover mechanism”](#) on page 169.

See [“I/O throttling”](#) on page 170.

### Path failover mechanism

The DMP feature of VxVM enhances system reliability when used with multiported disk arrays. In the event of the loss of a path to a disk array, DMP automatically selects the next available path for I/O requests without intervention from the administrator.

DMP is also informed when a connection is repaired or restored, and when you add or remove devices after the system has been fully booted (provided that the operating system recognizes the devices correctly).

If required, the response of DMP to I/O failure on a path can be tuned for the paths to individual arrays. DMP can be configured to time out an I/O request either after a given period of time has elapsed without the request succeeding, or after a given number of retries on a path have failed.

See [“Configuring the response to I/O failures”](#) on page 210.

## I/O throttling

If I/O throttling is enabled, and the number of outstanding I/O requests builds up on a path that has become less responsive, DMP can be configured to prevent new I/O requests being sent on the path either when the number of outstanding I/O requests has reached a given value, or a given time has elapsed since the last successful I/O request on the path. While throttling is applied to a path, the outstanding I/O requests on that path are scheduled on other available paths. The throttling is removed from the path if the HBA reports no error on the path, or if an outstanding I/O request on the path succeeds.

See [“Configuring the I/O throttling mechanism”](#) on page 211.

## Load balancing

By default, the DMP uses the Minimum Queue policy for load balancing across paths for Active/Active, A/P-C, A/PF-C and A/PG-C disk arrays. Load balancing maximizes I/O throughput by using the total bandwidth of all available paths. I/O is sent down the path which has the minimum outstanding I/Os.

For Active/Passive disk arrays, I/O is sent down the primary path. If the primary path fails, I/O is switched over to the other available primary paths or secondary paths. As the continuous transfer of ownership of LUNs from one controller to another results in severe I/O slowdown, load balancing across paths is not performed for Active/Passive disk arrays unless they support concurrent I/O.

Both paths of an Active/Passive array are not considered to be on different controllers when mirroring across controllers (for example, when creating a volume using `vxassist make` specified with the `mirror=ctlr` attribute).

For A/P-C, A/PF-C and A/PG-C arrays, load balancing is performed across all the currently active paths as is done for Active/Active arrays.

You can use the `vxdmppadm` command to change the I/O policy for the paths to an enclosure or disk array.

See [“Specifying the I/O policy”](#) on page 200.

## Dynamic Reconfiguration

Dynamic Reconfiguration (DR) is a feature that is available on some high-end enterprise systems. It allows some components (such as CPUs, memory, and other controllers or I/O boards) to be reconfigured while the system is still running. The reconfigured component might be handling the disks controlled by VxVM.

See [“Enabling and disabling I/O for controllers and storage processors”](#) on page 174.

## Booting from DMP devices

When the root disk is placed under VxVM control, it is automatically accessed as a DMP device with one path if it is a single disk, or with multiple paths if the disk is part of a multiported disk array. By encapsulating and mirroring the root disk, system reliability is enhanced against loss of one or more of the existing physical paths to a disk.

## DMP in a clustered environment

---

**Note:** You need an additional license to use the cluster feature of VxVM.

---

In a clustered environment where Active/Passive type disk arrays are shared by multiple hosts, all nodes in the cluster must access the disk via the same physical storage controller port. Accessing a disk via multiple paths simultaneously can severely degrade I/O performance (sometimes referred to as the ping-pong effect). Path failover on a single cluster node is also coordinated across the cluster so that all the nodes continue to share the same physical path.

Prior to release 4.1 of VxVM, the clustering and DMP features could not handle automatic failback in A/P arrays when a path was restored, and did not support failback for explicit failover mode arrays. Failback could only be implemented manually by running the `vxctl enable` command on each cluster node after the path failure had been corrected. From release 4.1, failback is now an automatic cluster-wide operation that is coordinated by the master node. Automatic failback in explicit failover mode arrays is also handled by issuing the appropriate low-level command.

---

**Note:** Support for automatic failback of an A/P array requires that an appropriate ASL (and APM, if required) is available for the array, and has been installed on the system.

---

For Active/Active type disk arrays, any disk can be simultaneously accessed through all available physical paths to it. In a clustered environment, the nodes do not all need to access a disk via the same physical path.

See [“How to administer the Device Discovery Layer”](#) on page 92.

See [“Configuring array policy modules”](#) on page 216.

### **Enabling or disabling controllers with shared disk groups**

Prior to release 5.0, VxVM did not allow enabling or disabling of paths or controllers connected to a disk that is part of a shared Veritas Volume Manager disk group. From VxVM 5.0 onward, such operations are supported on shared DMP nodes in a cluster.

## **Disabling multipathing and making devices invisible to VxVM**

Use this procedure to prevent a device from being multipathed by the VxVM DMP driver (`vxdmp`), or to exclude a device from the view of VxVM.

### To disable multipathing and make devices invisible to VxVM

- 1 Run the `vxdiskadm` command, and select `Prevent multipathing/Suppress devices from VxVM's view` from the main menu. You are prompted to confirm whether you want to continue.
- 2 Select the operation you want to perform from the following options:

Option 1	Suppresses all paths through the specified controller from the view of VxVM.
Option 2	Suppresses specified paths from the view of VxVM.
Option 3	Suppresses disks from the view of VxVM that match a specified Vendor ID and Product ID combination.
Option 4	Suppresses all but one path to a disk. Only one path is made visible to VxVM.
Option 5	Prevents multipathing for all disks on a specified controller by VxVM.
Option 6	Prevents multipathing of a disk by VxVM. The disks that correspond to a specified path are claimed in the <code>OTHER_DISKS</code> category and are not multipathed.
Option 7	Prevents multipathing for disks that match a specified Vendor ID and Product ID combination. The disks that correspond to a specified Vendor ID and Product ID combination are claimed in the <code>OTHER_DISKS</code> category and are not multipathed.
Option 8	Lists the devices that are currently suppressed or not multipathed.

## Enabling multipathing and making devices visible to VxVM

Use this procedure to re-enable multipathing for a device, or to make a device visible to VxVM again.

### To enable multipathing and make devices visible to VxVM

- 1 Run the `vxdiskadm` command, and select `Allow multipathing/Unsuppress devices from VxVM's view` from the main menu. You are prompted to confirm whether you want to continue.
- 2 Select the operation you want to perform from the following options:

Option 1	Unsuppresses all paths through the specified controller from the view of VxVM.
Option 2	Unsuppresses specified paths from the view of VxVM.
Option 3	Unsuppresses disks from the view of VxVM that match a specified Vendor ID and Product ID combination.
Option 4	Removes a pathgroup definition. (A pathgroup explicitly defines alternate paths to the same disk.) Once a pathgroup has been removed, all paths that were defined in that pathgroup become visible again.
Option 5	Allows multipathing of all disks that have paths through the specified controller.
Option 6	Allows multipathing of a disk by VxVM.
Option 7	Allows multipathing of disks that match a specified Vendor ID and Product ID combination.
Option 8	Lists the devices that are currently suppressed or not multipathed.

## Enabling and disabling I/O for controllers and storage processors

DMP allows you to turn off I/O for a controller or the array port of a storage processor so that you can perform administrative operations. This feature can be used for maintenance of HBA controllers on the host, or array ports that are attached to disk arrays supported by VxVM. I/O operations to the controller or array port can be turned back on after the maintenance task is completed. You can accomplish these operations using the `vxdkmpadm` command provided with VxVM.

For Active/Active type disk arrays, after disabling the I/O through an HBA controller or array port, the I/O continues on the remaining paths. For Active/Passive type disk arrays, if disabling I/O through an HBA controller or

array port resulted in all primary paths being disabled, DMP will failover to active secondary paths and I/O will continue on them.

After the operation is over, you can use `vxddmpadm` to re-enable the paths through the controllers.

See “[Disabling I/O for paths, controllers or array ports](#)” on page 206.

See “[Enabling I/O for paths, controllers or array ports](#)” on page 208.

See “[Upgrading disk controller firmware](#)” on page 208.

---

**Note:** From release 5.0 of VxVM, these operations are supported for controllers that are used to access disk arrays on which cluster-shareable disk groups are configured.

---

## Displaying DMP database information

You can use the `vxddmpadm` command to list DMP database information and perform other administrative tasks. This command allows you to list all controllers that are connected to disks, and other related information that is stored in the DMP database. You can use this information to locate system hardware, and to help you decide which controllers need to be enabled or disabled.

The `vxddmpadm` command also provides useful information such as disk array serial numbers, which DMP devices (disks) are connected to the disk array, and which paths are connected to a particular controller, enclosure or array port.

See “[Administering DMP using vxddmpadm](#)” on page 179.

## Displaying the paths to a disk

The `vxddisk` command is used to display the multipathing information for a particular metadvice. The metadvice is a device representation of a particular physical disk having multiple physical paths from one of the system’s HBA controllers. In VxVM, all the physical disks in the system are represented as metadevices with one or more physical paths.

**To display the multipathing information on a system**

- ◆ Use the `vxdisk path` command to display the relationships between the device paths, disk access names, disk media names and disk groups on a system as shown here:

```
# vxdisk path

SUBPATH      DANAME      DMNAME      GROUP      STATE
c1t0d0s2     c1t0d0s2    mydg01      mydg       ENABLED
c4t0d0s2     c1t0d0s2    mydg01      mydg       ENABLED
c1t1d0s2     c1t1d0s2    mydg02      mydg       ENABLED
c4t1d0s2     c1t1d0s2    mydg02      mydg       ENABLED
.
.
.
```

This shows that two paths exist to each of the two disks, `mydg01` and `mydg02`, and also indicates that each disk is in the `ENABLED` state.

**To view multipathing information for a particular metadvice**

- 1 Use the following command:

```
# vxdisk list devicename
```

For example, to view multipathing information for `c2t0d0s2`, use the following command:

```
# vxdisk list c2t0d0s2
```

Typical output from the `vxdisk list` command is as follows:

```
Device      c2t0d0
devicetag   c2t0d0
type        sliced
hostid      aparajita
disk        name=mydg01 id=861086917.1052.aparajita
group       name=mydg id=861086912.1025.aparajita
flags       online ready autoconfig autoimport imported
pubpaths    block=/dev/vx/dmp/c2t0d0s4 char=/dev/vx/rdmp/c2t0d0s4
privpaths   block=/dev/vx/dmp/c2t0d0s3 char=/dev/vx/rdmp/c2t0d0s3
version     2.1
iosize      min=512 (bytes) max=2048 (blocks)
public      slice=4 offset=0 len=1043840
private     slice=3 offset=1 len=1119
update      time=861801175 seqno=0.48
```



```

headers      0 248
configs      count=1 len=795
logs         count=1 len=120
Defined regions
config       priv 000017-000247[000231]:copy=01 offset=000000
enabled
config       priv 000249-000812[000564]:copy=01 offset=000231
enabled
log          priv 000813-000932[000120]:copy=01 offset=000000
enabled
Multipathing information:
numpaths:    2
c2t0d0s2    state=enabled      type=primary
c1t0d0s2    state=disabled     type=secondary

```

In the `Multipathing information` section of this output, the `numpaths` line shows that there are 2 paths to the device, and the following two lines show that one path is active (`state=enabled`) and that the other path has failed (`state=disabled`).

The `type` field is shown for disks on Active/Passive type disk arrays such as the EMC CLARiiON, Hitachi HDS 9200 and 9500, Sun StorEdge 6xxx, and Sun StorEdge T3 array. This field indicates the primary and secondary paths to the disk.

The `type` field is not displayed for disks on Active/Active type disk arrays such as the EMC Symmetrix, Hitachi HDS 99xx and Sun StorEdge 99xx Series, and IBM ESS Series. Such arrays have no concept of primary and secondary paths.

- 2 Alternately, you can use the following command to view multipathing information:

```
# vxddmpadm getsubpaths dmpnodename=devicename
```

For example, to view multipathing information for `eva4k6k0_6`, use the following command:

```
# vxddmpadm getsubpaths dmpnodename=eva4k6k0_6
```

Typical output from the `vxddmpadm getsubpaths` command is as follows:

NAME	STATE [A]	PATH-TYPE [M]	CTLR-NAME	ENCLR-TYPE	ENCLR-NAME	ATTRS
c0t50001FE1500A8F08d7s2	ENABLED (A)	PRIMARY	c0	EVA4K6K	eva4k6k0	-
c0t50001FE1500A8F09d7s2	ENABLED (A)	PRIMARY	c0	EVA4K6K	eva4k6k0	-

c0t50001FE1500A8F0Cd7s2	ENABLED	SECONDARY	c0	EVA4K6K	eva4k6k0	-
c0t50001FE1500A8F0Dd7s2	ENABLED	SECONDARY	c0	EVA4K6K	eva4k6k0	-

## Setting customized names for DMP nodes

The DMP node name is the meta device name which represents the multiple paths to a disk. The DMP node name is generated from the device name according to the VxVM naming scheme.

See [“Disk device naming in VxVM”](#) on page 83.

You can specify a customized name for a DMP node. User-specified names are persistent even if names persistence is turned off.

### To specify a custom name for a DMP node

- ◆ Use the following command:

```
# vxddmpadm setattr dmpnode dmpnodename name=name
```

You can also assign names from an input file. This enables you to customize the DMP nodes on the system with meaningful names.

### To assign DMP nodes from a file

- 1 Use the script `vxgetdmpnames` to get a sample file populated from the devices in your configuration. The sample file shows the format required and serves as a template to specify your customized names.
- 2 To assign the names, use the following command:

```
# vxddladm assign names file=pathname
```

### To clear custom names

- ◆ To clear the names, and use the default OSN or EBN names, use the following command:

```
# vxddladm -c assign names
```

## DMP coexistence with native multipathing

Dynamic multipathing (DMP) supports using multipathing with raw devices. The `dmp_native_multipathing` tunable controls the behavior. If the

`dmp_native_multipathing` tunable is set to on, DMP intercepts I/O requests, operations such as open, close, and ioctls sent on the raw device path.

If the `dmp_native_multipathing` tunable is set to off, these requests are sent directly to the raw device. In A/PF arrays, the format command on Solaris platform does not show the extra attributes (like vendor ID, product ID and geometry information) of the passive paths. To avoid this issue, enable the `dmp_native_multipathing` tunable. DMP intercepts the request and routes it on the primary path.

For A/P arrays, turning on the `dmp_native_multipathing` feature enables the commands to succeed without trespassing. The feature has no benefit for A/A or A/A-A arrays.

Veritas DMP cannot be enabled if EMC PowerPath is installed, or if MPxIO is enabled. In those cases, Veritas DMP is not required since the devices use native multipathing.

## Administering DMP using vxddmpadm

The `vxddmpadm` utility is a command line administrative interface to the DMP feature of VxVM.

You can use the `vxddmpadm` utility to perform the following tasks:

- Retrieve the name of the DMP device corresponding to a particular path.
- Display the members of a LUN group.
- List all paths under a DMP device node, HBA controller or array port.
- Display information about the HBA controllers on the host.
- Display information about enclosures.
- Display information about array ports that are connected to the storage processors of enclosures.
- Display information about devices that are controlled by third-party multipathing drivers.
- Gather I/O statistics for a DMP node, enclosure, path or controller.
- Configure the attributes of the paths to an enclosure.
- Set the I/O policy that is used for the paths to an enclosure.
- Enable or disable I/O for a path, HBA controller or array port on the system.
- Upgrade disk controller firmware.
- Rename an enclosure.

- Configure how DMP responds to I/O request failures.
- Configure the I/O throttling mechanism.
- Control the operation of the DMP path restoration thread.
- Get or set the values of various tunables used by DMP.

The following sections cover these tasks in detail along with sample output.

See [“Changing the values of tunables”](#) on page 555.

See the vxddmpadm(1M) manual page.

## Retrieving information about a DMP node

The following command displays the DMP node that controls a particular physical path:

```
# vxddmpadm getdmpnode nodename=c0t5006016041E03B33d0s2
```

The physical path is specified by argument to the `nodename` attribute, which must be a valid path listed in the `/dev/rdisk` directory.

The command displays output similar to the following:

NAME	STATE	ENCLR-TYPE	PATHS	ENBL	DSBL	ENCLR-NAME
emc_clariion0_162	ENABLED	EMC_CLARiion	6	6	0	emc_clariion0

Use the `-v` option to display the LUN serial number and the array volume ID.

```
# vxddmpadm -v getdmpnode nodename=c0t5006016041E03B33d0s2
```

NAME	STATE	ENCLR-TYPE	PATHS	ENBL	DSBL	ENCLR-NAME	SERIAL-NO	ARRAY_VOI
emc_clariion0_162	ENABLED	EMC_CLARiion	6	6	0	emc_clariion0	600601606D121B007C778BC48EDB	

Use the `enclosure` attribute with `getdmpnode` to obtain a list of all DMP nodes for the specified enclosure.

```
# vxddmpadm getdmpnode enclosure=enc0
```

NAME	STATE	ENCLR-TYPE	PATHS	ENBL	DSBL	ENCLR-NAME
c2t1d0s2	ENABLED	T300	2	2	0	enc0
c2t1d1s2	ENABLED	T300	2	2	0	enc0
c2t1d2s2	ENABLED	T300	2	2	0	enc0
c2t1d3s2	ENABLED	T300	2	2	0	enc0

Use the `dmpnodename` attribute with `getddmpnode` to display the DMP information for a given DMP node.

```
# vxddmpadm getddmpnode dmpnodename=emc_clariion0_158
```

NAME	STATE	ENCLR-TYPE	PATHS	ENBL	DSBL	ENCLR-NAME
emc_clariion0_158	ENABLED	EMC_CLARIION	1	1	0	emc_clariion0

## Displaying consolidated information about the DMP nodes

The `vxddmpadm list dmpnode` command displays the detail information of a DMP node. The information includes the enclosure name, LUN serial number, port id information, device attributes, etc.

The following command displays the consolidated information for all of the DMP nodes in the system:

```
# vxddmpadm list dmpnode all
```

Use the `enclosure` attribute with `list dmpnode` to obtain a list of all DMP nodes for the specified enclosure.

```
# vxddmpadm list dmpnode enclosure=enclosure name
```

For example, the following command displays the consolidated information for all of the DMP nodes in the `enc0` enclosure.

```
#vxddmpadm list dmpnode enclosure=enc0
```

Use the `dmpnodename` attribute with `list dmpnode` to display the DMP information for a given DMP node. The DMP node can be specified by name or by specifying a path name. The detailed information for the specified DMP node includes path information for each subpath of the listed dmpnode.

The path state differentiates between a path that is disabled due to a failure and a path that has been manually disabled for administrative purposes. A path that has been manually disabled using the `vxddmpadm disable` command is listed as `disabled(m)`.

```
# vxddmpadm list dmpnode dmpnodename=dmpnodename
```

For example, the following command displays the consolidated information for the DMP node `emc_clariion0_158`.

```
# vxddmpadm list dmpnode dmpnodename=emc_clariion0_158
```

```
dmpdev           = emc_clariion0_158
state            = enabled
enclosure       = emc_clariion0
cab-sno         = CK200070400359
asl             = libvxCLARiion.so
vid            = DGC
pid            = DISK
array-name      = EMC_CLARiion
array-type     = CLR-A/PF
iopolicy       = MinimumQ
avid           = 158
lun-sno        = 600601606D121B008FB6E0CA8EDDB11
udid          = DGC%5FDISK%5FCK200070400359%5F600601606D121B008FB6E0CA8EDDB11
dev-attr       = lun
###path        = name state type transport ctrl hwpath apertID apertWWN attr
path           = c0t5006016141E03B33d1s2 enabled(a) primary FC c0
/pci@1e,600000/SUNW,emlxs@3/fp@0,0 A5 50:06:01:61:41:e0:3b:33 -
path           = c0t5006016041E03B33d1s2 enabled(a) primary FC c0
/pci@1e,600000/SUNW,emlxs@3/fp@0,0 A4 50:06:01:60:41:e0:3b:33 -
path           = c0t5006016841E03B33d1s2 enabled secondary FC c0
/pci@1e,600000/SUNW,emlxs@3/fp@0,0 B4 50:06:01:68:41:e0:3b:33 -
path           = c1t5006016141E03B33d1s2 enabled(a) primary FC c1
/pci@1e,600000/SUNW,emlxs@3,1/fp@0,0 A5 50:06:01:61:41:e0:3b:33 -
path           = c1t5006016841E03B33d1s2 enabled secondary FC c1
/pci@1e,600000/SUNW,emlxs@3,1/fp@0,0 B4 50:06:01:68:41:e0:3b:33 -
path           = c1t5006016041E03B33d1s2 enabled(a) primary FC c1
/pci@1e,600000/SUNW,emlxs@3,1/fp@0,0 A4 50:06:01:60:41:e0:3b:33 -
```

## Displaying the members of a LUN group

The following command displays the DMP nodes that are in the same LUN group as a specified DMP node:

```
# vxddmpadm getlungroup dmpnodename=c11t0d10s2
```

The above command displays output such as the following:

NAME	STATE	ENCLR-TYPE	PATHS	ENBL	DSBL	ENCLR-NAME
c11t0d8s2	ENABLED	ACME	2	2	0	enc1
c11t0d9s2	ENABLED	ACME	2	2	0	enc1
c11t0d10s2	ENABLED	ACME	2	2	0	enc1
c11t0d11s2	ENABLED	ACME	2	2	0	enc1

## Displaying paths controlled by a DMP node, controller, enclosure, or array port

The `vxddmpadm getsubpaths` command lists all of the paths known to DMP. The `vxddmpadm getsubpaths` command also provides options to list the subpaths through a particular DMP node, controller, enclosure, or array port. To list the paths through an array port, specify either a combination of enclosure name and array port id, or array port WWN.

To list all subpaths known to DMP:

```
# vxddmpadm getsubpaths
```

NAME	STATE [A]	PATH-TYPE [M]	DMPNODENAME	ENCLR-NAME	CTLR	ATTRS
c1t65d0s2	ENABLED (A)	-	Disk_1	Disk	c1	-
c1t66d0s2	ENABLED (A)	-	Disk_2	Disk	c1	-
c2t65d0s2	ENABLED (A)	-	Disk_1	Disk	c2	-
c2t66d0s2	ENABLED (A)	-	Disk_2	Disk	c2	-
c3t2d0s2	ENABLED (A)	-	EMC0_1	EMC0	c3	-
c3t2d1s2	ENABLED (A)	-	EMC0_2	EMC0	c3	-
c4t2d0s2	ENABLED (A)	-	EMC0_1	EMC0	c4	-
c4t2d1s2	ENABLED (A)	-	EMC0_2	EMC0	c4	-

The `vxddmpadm getsubpaths` command combined with the `dmpnodename` attribute displays all the paths to a LUN that are controlled by the specified DMP node name from the `/dev/vx/rdmp` directory:

```
# vxddmpadm getsubpaths dmpnodename=c2t66d0s2
```

NAME	STATE [A]	PATH-TYPE [M]	CTLR-NAME	ENCLR-TYPE	ENCLR-NAME	ATTRS
c2t66d0s2	ENABLED (A)	PRIMARY	c2	ACME	enc0	-
c1t66d0s2	ENABLED	PRIMARY	c1	ACME	enc0	-

For A/A arrays, all enabled paths that are available for I/O are shown as `ENABLED (A)`.

For A/P arrays in which the I/O policy is set to `singleactive`, only one path is shown as `ENABLED (A)`. The other paths are enabled but not available for I/O. If the I/O policy is not set to `singleactive`, DMP can use a group of paths (all primary or all secondary) for I/O, which are shown as `ENABLED (A)`.

See [“Specifying the I/O policy”](#) on page 200.

Paths that are in the `DISABLED` state are not available for I/O operations.

A path that was manually disabled by the system administrator displays as DISABLED(M). A path that failed displays as DISABLED.

You can use `getsubpaths` to obtain information about all the paths that are connected to a particular HBA controller:

```
# vxddmpadm getsubpaths ctlr=c2
```

```
NAME          STATE [-]  PATH-TYPE [-]  CTLR-NAME  ENCLR-TYPE  ENCLR-NAME  ATTRS
=====
c2t1d0s2  ENABLED   PRIMARY        c2t1d0s2   ACME        enc0        -
c2t2d0s2  ENABLED   PRIMARY        c2t2d0s2   ACME        enc0        -
c2t3d0s2  DISABLED  SECONDARY      c2t3d0s2   ACME        enc0        -
c2t4d0s2  ENABLED   SECONDARY      c2t4d0s2   ACME        enc0        -
```

You can also use `getsubpaths` to obtain information about all the paths that are connected to a port on an array. The array port can be specified by the name of the enclosure and the array port ID, or by the worldwide name (WWN) identifier of the array port:

```
# vxddmpadm getsubpaths enclosure=HDS9500V0 portid=1A
# vxddmpadm getsubpaths pwn=20:00:00:E0:8B:06:5F:19
```

For example, to list subpaths through an array port:

```
# vxddmpadm getsubpaths enclosure=HDS9500-ALUA0 portid=1A
```

```
NAME          STATE [A]  PATH-TYPE [M]  DMPNODENAME  ENCLR-NAME  CTLR  ATTRS
=====
c1t65d0s2  ENABLED (A)  PRIMARY        c1t65d0s2   HDS9500-ALUA0  c1    -
c1t66d0s2  ENABLED (A)  PRIMARY        c1t66d0s2   HDS9500-ALUA0  c1    -
```

You can use `getsubpaths` to obtain information about all the subpaths of an enclosure.

```
# vxddmpadm getsubpaths enclosure=enclosure_name [ctlr=ctlrname]
```

To list all subpaths of an enclosure:

```
# vxddmpadm getsubpaths enclosure=Disk
```

```
NAME          STATE [A]  PATH-TYPE [M]  DMPNODENAME  ENCLR-NAME  CTLR  ATTRS
=====
c1t65d0s2  ENABLED (A)  -              Disk_1        Disk        c1    -
c1t66d0s2  ENABLED (A)  -              Disk_2        Disk        c1    -
c2t65d0s2  ENABLED (A)  -              Disk_1        Disk        c2    -
c2t66d0s2  ENABLED (A)  -              Disk_2        Disk        c2    -
```



To list all subpaths of a controller on an enclosure:

```
# vxddpadmin getsubpaths enclosure=Disk ctrlr=c1
```

NAME	STATE [A]	PATH-TYPE [M]	DMPNODENAME	ENCLR-NAME	CTRLR	ATTRS
c1t65d0s2	ENABLED (A)	-	Disk_1	Disk	c1	-
c1t66d0s2	ENABLED (A)	-	Disk_2	Disk	c1	-

By default, the output of the `vxddpadmin getsubpaths` command is sorted by enclosure name, DMP node name, and within that, path name. To sort the output based on the pathname, the DMP node name, the enclosure name, or the host controller name, use the `-s` option.

To sort subpaths information, use the following command:

```
# vxddpadmin -s {path | dmpnode | enclosure | ctrlr} getsubpaths \
[all | ctrlr=ctrlr_name | dmpnodename=dmp_device_name | \
enclosure=enclr_name [ctrlr=ctrlr_name | portid=array_port_ID] | \
pwwn=port_WWN | tpdnodename=tpd_node_name]
```

## Displaying information about controllers

The following command lists attributes of all HBA controllers on the system:

```
# vxddpadmin listctrlr all
```

CTRLR-NAME	ENCLR-TYPE	STATE	ENCLR-NAME
c1	OTHER	ENABLED	other0
c2	X1	ENABLED	jbod0
c3	ACME	ENABLED	enc0
c4	ACME	ENABLED	enc0

This output shows that the controller `c1` is connected to disks that are not in any recognized DMP category as the enclosure type is `OTHER`.

The other controllers are connected to disks that are in recognized DMP categories.

All the controllers are in the `ENABLED` state which indicates that they are available for I/O operations.

The state `DISABLED` is used to indicate that controllers are unavailable for I/O operations. The unavailability can be due to a hardware failure or due to I/O operations being disabled on that controller by using the `vxddpadmin disable` command.

The following forms of the command lists controllers belonging to a specified enclosure or enclosure type:

```
# vxddmpadm listctlr enclosure=enc0
```

or

```
# vxddmpadm listctlr type=ACME
```

CTLR-NAME	ENCLR-TYPE	STATE	ENCLR-NAME
c2	ACME	ENABLED	enc0
c3	ACME	ENABLED	enc0

The `vxddmpadm getctlr` command displays HBA vendor details and the Controller ID. For iSCSI devices, the Controller ID is the IQN or IEEE-format based name. For FC devices, the Controller ID is the WWN. Because the WWN is obtained from ESD, this field is blank if ESD is not running. ESD is a daemon process used to notify DDL about occurrence of events. The WWN shown as 'Controller ID' maps to the WWN of the HBA port associated with the host controller.

```
# vxddmpadm getctlr c5
```

LNAME	PNAME	HBA-VENDOR	CTLR-ID
c5	c5	qlogic	20:07:00:a0:b8:17:e1:37
c6	c6	qlogic	iqn.1986-03.com.sun:01:0003ba8ed1b5.45220f80

## Displaying information about enclosures

To display the attributes of a specified enclosure, including its enclosure type, enclosure serial number, status, array type, and number of LUNs, use the following command:

```
# vxddmpadm listenclosure enc0
```

ENCLR_NAME	ENCLR_TYPE	ENCLR_SNO	STATUS	ARRAY_TYPE	LUN_COUNT
enc0	T3	60020f20000001a90000	CONNECTED	A/P	30

The following command lists attributes for all enclosures in a system:

```
# vxddmpadm listenclosure all
```

ENCLR_NAME	ENCLR_TYPE	ENCLR_SNO	STATUS	ARRAY_TYPE	LUN_COUNT
Disk	Disk	DISKS	CONNECTED	Disk	6

```
SENA0      SENA      508002000001d660    CONNECTED  A/A      57
enc0      T3        60020f20000001a90000 CONNECTED  A/P      30
```

## Displaying information about array ports

To display the attributes of an array port that is accessible via a path, DMP node or HBA controller, use one of the following commands:

```
# vxddm getportids path=path-name
# vxddm getportids dmpnodename=dmpnode-name
# vxddm getportids ctrl=ctrl-name
```

The information displayed for an array port includes the name of its enclosure, and its ID and worldwide name (WWN) identifier.

The following form of the command displays information about all of the array ports within the specified enclosure:

```
# vxddm getportids enclosure=enclr-name
```

The following example shows information about the array port that is accessible via DMP node `c2t66d0s2`:

```
# vxddm getportids dmpnodename=c2t66d0s2
```

NAME	ENCLR-NAME	ARRAY-PORT-ID	pWWN
c2t66d0s2	HDS9500V0	1A	20:00:00:E0:8B:06:5F:19

## Displaying information about TPD-controlled devices

The third-party driver (TPD) coexistence feature allows I/O that is controlled by third-party multipathing drivers to bypass DMP while retaining the monitoring capabilities of DMP. The following commands allow you to display the paths that DMP has discovered for a given TPD device, and the TPD device that corresponds to a given TPD-controlled node discovered by DMP:

```
# vxddm getsubpaths tpdnodename=TPD_node_name
# vxddm gettpdnode nodename=TPD_path_name
```

See [“Changing device naming for TPD-controlled enclosures”](#) on page 110.

For example, consider the following disks in an EMC Symmetrix array controlled by PowerPath, which are known to DMP:

```
# vxddisk list
```

DEVICE	TYPE	DISK	GROUP	STATUS
emcpower10s2	auto:sliced	disk1	ppdg	online
emcpower11s2	auto:sliced	disk2	ppdg	online
emcpower12s2	auto:sliced	disk3	ppdg	online
emcpower13s2	auto:sliced	disk4	ppdg	online
emcpower14s2	auto:sliced	disk5	ppdg	online
emcpower15s2	auto:sliced	disk6	ppdg	online
emcpower16s2	auto:sliced	disk7	ppdg	online
emcpower17s2	auto:sliced	disk8	ppdg	online
emcpower18s2	auto:sliced	disk9	ppdg	online
emcpower19s2	auto:sliced	disk10	ppdg	online

The following command displays the paths that DMP has discovered, and which correspond to the PowerPath-controlled node, emcpower10s2:

```
# vxddmpadm getsubpaths tpdnodename=emcpower10s2
```

NAME	TPDNODENAME	PATH-TYPE [-] DMP-NODENAME	ENCLR-TYPE	ENCLR-NAME
c7t0d10s2emcpower10s2-		emcpower10s2	EMC	EMC0
c6t0d10s2emcpower10s2-		emcpower10s2	EMC	EMC0

Conversely, the next command displays information about the PowerPath node that corresponds to the path, c7t0d10s2, discovered by DMP:

```
# vxddmpadm gettpdnode nodename=c7t0d10s2
```

NAME	STATE	PATHS	ENCLR-TYPE	ENCLR-NAME
emcpower10s2	ENABLED	2	EMC	EMC0

## Displaying extended device attributes

Device Discovery Layer (DDL) extended attributes are attributes or flags corresponding to a VxVM LUN/Disk which are discovered by DDL. These attributes identify a LUN to a specific hardware category.

The list of categories includes:

Hardware RAID types	Displays what kind of Storage RAID Group the LUN belongs to
Thin Provisioning Discovery and Reclamation	Displays the LUN's thin/reclamation abilities

Device Media Type	Displays the type of media –whether SSD (solid state disk )
Storage-based Snapshot/Clone	Displays whether the LUNS is a SNAPSHOT or a CLONE of a PRIMARY LUN
Storage-based replication	Displays if LUN is part of a replicated group across a remote site
Transport	Displays what kind of HBA is used to connect to this LUN ( FC , SATA , iSCSI )

Each LUN can have one or more of these attributes discovered during device discovery. ASLs furnish this information to DDL through the property DDL\_DEVICE\_ATTR. The `vxddisk -p list` command displays DDL extended attributes. For example, the following command shows attributes of “std”, “fc”, and “RAID\_5” for this LUN:

```
# vxddisk -p list
DISK           : tagmastore-usp0_0e18
DISKID        : 1253585985.692.rx2600h11
VID           : HITACHI
UDID          : HITACHI%5FOPEN-V%5F02742%5F0E18
REVISION      : 5001
PID           : OPEN-V
PHYS_CTLR_NAME : 0/4/1/1.0x50060e8005274246
LUN_SNO_ORDER : 411
LUN_SERIAL_NO  : 0E18
LIBNAME       : libvxhdsusp.sl
HARDWARE_MIRROR : no
DMP_DEVICE     : tagmastore-usp0_0e18
DDL_THIN_DISK  : thick
DDL_DEVICE_ATTR : std fc RAID_5
CAB_SERIAL_NO  : 02742
ATYPE         : A/A
ARRAY_VOLUME_ID : 0E18
ARRAY_PORT_PWWN : 50:06:0e:80:05:27:42:46
ANAME         : TagmaStore-USP
TRANSPORT      : FC
```

The `vxddisk -x attribute -p list` command displays the one-line listing for the property list and the attributes. The following example shows two Hitachi LUNs that support Thin Reclamation support via the attribute `hdprclm`:

```
# vxdisk -x DDL_DEVICE_ATTR -p list
DEVICE                DDL_DEVICE_ATTR
tagmastore-usp0_0a7a  std fc
RAID_5
tagmastore-usp0_065a  hdprclm fc
tagmastore-usp0_065b  hdprclm fc
```

User can specify multiple -x options in the same command to display multiple entries. For example:

```
# vxdisk -x DDL_DEVICE_ATTR -x VID -p list

DEVICE                VID                DDL_DEVICE_ATTR
tagmastore-usp0_0a7a  HITACHI           std fc RAID_5
tagmastore-usp0_0a7b  HITACHI           std fc RAID_5
tagmastore-usp0_0a78  HITACHI           std fc RAID_5
tagmastore-usp0_0a79  HITACHI           std fc RAID_5
tagmastore-usp0_065a  HITACHI           hdprclm fc
tagmastore-usp0_065b  HITACHI           hdprclm fc
tagmastore-usp0_065c  HITACHI           hdprclm fc
tagmastore-usp0_065d  HITACHI           hdprclm fc
```

Use the `vxdisk -e list` command to show the `DDL_DEVICE_ATTR` property in the last column named `ATTR`.

```
# vxdisk -e list
DEVICE                TYPE  DISK  GROUP  STATUS  OS_NATIVE_NAME  ATTR
tagmastore-usp0_0a7a  auto  -     -      online  c10t0d2         std fc RAID_5
tagmastore-usp0_0a7b  auto  -     -      online  c10t0d3         std fc RAID_5
tagmastore-usp0_0a78  auto  -     -      online  c10t0d0         std fc RAID_5
tagmastore-usp0_0655  auto  -     -      online  c13t2d7         hdprclm fc
tagmastore-usp0_0656  auto  -     -      online  c13t3d0         hdprclm fc
tagmastore-usp0_0657  auto  -     -      online  c13t3d1         hdprclm fc
```

For a list of ASLs that supports Extended Attributes, and descriptions of these attributes, refer to the hardware compatibility list at the following URL:

<http://seer.entsupport.symantec.com/docs/330441.htm>

## Suppressing or including devices for VxVM or DMP control

The `vxmpadm exclude` command suppresses devices from VxVM based on the criteria that you specify. The devices can be added back into VxVM control by using the `vxmpadm include` command. The devices can be included or excluded

based on VID:PID combination, paths, controllers, or disks. You can use the bang symbol (!) to exclude or include any paths or controllers except the one specified.

---

**Note:** The ! character is a special character in some shells. The following syntax shows how to escape it in a bash shell.

---

```
# vxddmpadm exclude [vxvm | vxddmp] { all | product=VID:PID |
ctrl=[\!]ctrl | dmpnodename=diskname [ path=\!pathname] }

# vxddmpadm include [vxvm | vxddmp] { all | product=VID:PID |
ctrl=[\!]ctrl | dmpnodename=diskname [ path=\!pathname] }
```

where:

**all** – all devices

**product=VID:PID** – all devices with the specified VID:PID

**ctrl=ctrl** – all devices through the given controller

**dmpnodename=diskname** – all paths under the DMP node

**dmpnodename=diskname path=\!pathname** – all paths under the DMP node except the one specified.

## Gathering and displaying I/O statistics

You can use the `vxddmpadm iostat` command to gather and display I/O statistics for a specified DMP node, enclosure, path or controller.

To enable the gathering of statistics, enter this command:

```
# vxddmpadm iostat start [memory=size]
```

To reset the I/O counters to zero, use this command:

```
# vxddmpadm iostat reset
```

The `memory` attribute can be used to limit the maximum amount of memory that is used to record I/O statistics for each CPU. The default limit is 32k (32 kilobytes) per CPU.

To display the accumulated statistics at regular intervals, use the following command:

```
# vxddmpadm iostat show {all | dmpnodename=dmp-node | \
enclosure=enclr-name | pathname=path-name | ctrl=ctrl-name} \
[interval=seconds [count=N]]
```

This command displays I/O statistics for all paths (`all`), or for a specified DMP node, enclosure, path or controller. The statistics displayed are the CPU usage and amount of memory per CPU used to accumulate statistics, the number of read and write operations, the number of kilobytes read and written, and the average time in milliseconds per kilobyte that is read or written.

The `interval` and `count` attributes may be used to specify the interval in seconds between displaying the I/O statistics, and the number of lines to be displayed. The actual interval may be smaller than the value specified if insufficient memory is available to record the statistics.

To disable the gathering of statistics, enter this command:

```
# vxddmpadm iostat stop
```

## Examples of using the vxddmpadm iostat command

The following is an example session using the `vxddmpadm iostat` command. The first command enables the gathering of I/O statistics:

```
# vxddmpadm iostat start
```

The next command displays the current statistics including the accumulated total numbers of read and write operations and kilobytes read and written, on all paths:

```
# vxddmpadm iostat show all
                cpu usage = 7952us      per cpu memory = 8192b
OPERATIONS          KBYTES          AVG TIME (ms)
PATHNAME  READS    WRITES    READS    WRITES    READS    WRITES
c0t0d0    1088      0      557056    0      0.00    0.00
c2t118d0   87       0      44544    0      0.00    0.00
c3t118d0   0       0       0       0      0.00    0.00
c2t122d0   87       0      44544    0      0.00    0.00
c3t122d0   0       0       0       0      0.00    0.00
c2t115d0   87       0      44544    0      0.00    0.00
c3t115d0   0       0       0       0      0.00    0.00
c2t103d0   87       0      44544    0      0.00    0.00
c3t103d0   0       0       0       0      0.00    0.00
c2t102d0   87       0      44544    0      0.00    0.00
c3t102d0   0       0       0       0      0.00    0.00
c2t121d0   87       0      44544    0      0.00    0.00
c3t121d0   0       0       0       0      0.00    0.00
c2t112d0   87       0      44544    0      0.00    0.00
c3t112d0   0       0       0       0      0.00    0.00
c2t96d0    87       0      44544    0      0.00    0.00
c3t96d0    0       0       0       0      0.00    0.00
```



```

c2t106d0      87      0      44544      0      0.00      0.00
c3t106d0      0      0      0      0      0.00      0.00
c2t113d0     87      0      44544      0      0.00      0.00
c3t113d0      0      0      0      0      0.00      0.00
c2t119d0     87      0      44544      0      0.00      0.00
c3t119d0      0      0      0      0      0.00      0.00

```

The following command changes the amount of memory that vxddpdm can use to accumulate the statistics:

```
# vxddpdm iostat start memory=4096
```

The displayed statistics can be filtered by path name, DMP node name, and enclosure name (note that the per-CPU memory has changed following the previous command):

```

# vxddpdm iostat show pathname=c3t115d0s2
                cpu usage = 8132us   per cpu memory = 4096b
                OPERATIONS          BYTES          AVG TIME(ms)
PATHNAME  READS    WRITES    READS    WRITES    READS    WRITES
c3t115d0s2      0      0      0      0      0.00    0.00

```

```

# vxddpdm iostat show dmpnodename=c0t0d0s2
                cpu usage = 8501us   per cpu memory = 4096b
                OPERATIONS          BYTES          AVG TIME(ms)
PATHNAME  READS    WRITES    READS    WRITES    READS    WRITES
c0t0d0 s2  1088      0    557056      0      0.00    0.00

```

```

# vxddpdm iostat show enclosure=Disk
                cpu usage = 8626us   per cpu memory = 4096b
                OPERATIONS          BYTES          AVG TIME(ms)
PATHNAME  READS    WRITES    READS    WRITES    READS    WRITES
c0t0d0 s2  1088      0    557056      0      0.00    0.00

```

You can also specify the number of times to display the statistics and the time interval. Here the incremental statistics for a path are displayed twice with a 2-second interval:

```

$vxddpdm iostat show dmpnodename=emc_clariion0_342 interval=1 count=2
                cpu usage = 164687us  per cpu memory = 409600b
                OPERATIONS          BLOCKS          AVG TIME(ms)
PATHNAME  READS    WRITES    READS    WRITES    READS    WRITES
c0t5006016041E03B33d6s2  3      0      33      0      0.02    0.00
c0t5006016141E03B33d6s2  3      0      3      0      0.16    0.00
c0t5006016841E03B33d6s2  0      0      0      0      0.00    0.00

```

```

c1t5006016041E03B33d6s2 1      0      16      0      0.02      0.00
c1t5006016141E03B33d6s2 2      0       2      0      0.18      0.00
c1t5006016841E03B33d6s2 0      0       0      0      0.00      0.00

c0t5006016041E03B33d6s2 0      0       0      0      0.00      0.00
c0t5006016141E03B33d6s2 0      0       0      0      0.00      0.00
c0t5006016841E03B33d6s2 0      0       0      0      0.00      0.00
c1t5006016041E03B33d6s2 0      0       0      0      0.00      0.00
c1t5006016141E03B33d6s2 0      0       0      0      0.00      0.00
c1t5006016841E03B33d6s2 0      0       0      0      0.00      0.00

```

## Displaying statistics for queued or erroneous I/Os

Use the `vxddmpadm iostat show` command with the `-q` option to display the I/Os queued in DMP for a specified DMP node, or for a specified path or controller. For a DMP node, the `-q` option displays the I/Os on the specified DMP node that were sent to underlying layers. If a path or controller is specified, the `-q` option displays I/Os that were sent to the given path or controller and not yet returned to DMP.

See the `vxddmpadm(1m)` manual page for more information about the `vxddmpadm iostat` command.

To display queued I/O counts on a DMP node:

```
# vxddmpadm -q iostat show [filter]
[interval=n [count=m]]
```

For example:

```
# vxddmpadm -q iostat show dmpnodename=c5t2d1s2
```

```

QUEUED I/Os          Pending I/Os
DMPNODENAME  READS  WRITES
c5t2d1s2      2     15          30

```

To display the count of I/Os that returned with errors on a DMP node, path or controller:

```
# vxddmpadm -e iostat show [filter]
[interval=n [count=m]]
```

For example, to show the I/O counts that returned errors on a path:

```
# vxddmpadm -e iostat show pathname=c1t5006016041E03B33d6s2 interval=1
```

```

cpu usage = 168144us      per cpu memory = 409600b
                                ERROR I/Os

```

PATHNAME	READS	WRITES	
c1t5006016041E03B33d6s2		0	0
c1t5006016041E03B33d6s2		0	0

## Displaying cumulative I/O statistics

Use the `groupby` clause of the `vxddpdm iostat` command to display cumulative I/O statistics listings per DMP node, controller, array port id, or host-array controller pair and enclosure. If the `groupby` clause is not specified, then the statistics are displayed per path.

To group by DMP node:

```
# vxddpdm iostat show groupby=dmpnode [all | dmpnodename=dmpnodename
| enclosure=enclr-name]
```

For example:

```
# vxddpdm iostat show groupby=dmpnode dmpnodename=c5t0d1s2
```

DMPNODENAME	OPERATIONS		BLOCKS		AVG TIME (ms)	
	READS	WRITES	READS	WRITES	READS	WRITES
c5t0d1s2	0	0	0	0	0.00	0.00

To group by controller:

```
# vxddpdm iostat show groupby=ctlr [ all | ctlr=ctlr ]
```

For example:

```
# vxddpdm iostat show groupby=ctlr ctlr=c5
```

CTLRNAME	OPERATIONS		BLOCKS		AVG TIME (ms)	
	READS	WRITES	READS	WRITES	READS	WRITES
c5	224	14	54	7	4.20	11.10

To group by arrayport:

```
# vxddpdm iostat show groupby=arrayport [ all | pwwn=array port wwn
| enclosure=enclr portid=array-port-id ]
```

For example:

```
# vxddpdm iostat show groupby=arrayport enclosure=HDS9500-ALUA0 portid=1A
```

PORTNAME	OPERATIONS		BLOCKS		AVG TIME (ms)	
	READS	WRITES	READS	WRITES	READS	WRITES
1A	224	14	54	7	4.20	11.10

To group by enclosure:

```
# vxddmpadm iostat show groupby=enclosure [ all | enclosure=enc1r ]
```

For example:

```
# vxddmpadm iostat show groupby=enclosure enclosure=EMC_CLARiiON0
```

ENCLRNAME	OPERATIONS		BLOCKS		AVG TIME (ms)	
	READS	WRITES	READS	WRITES	READS	WRITES
EMC_CLARiiON0	0	0	0	0	0.00	0.00

You can also filter out entities for which all data entries are zero. This option is especially useful in a cluster environment which contains many failover devices. You can display only the statistics for the active paths.

To filter all zero entries from the output of the `iostat show` command:

```
# vxddmpadm -z iostat show [all|ctlr=ctlr_name |  
dmpnodename=dmp_device_name | enclosure=enc1r_name [portid=portid] |  
pathname=path_name|pwwn=port_WWN] [interval=seconds [count=N]]
```

For example:

```
# vxddmpadm -z iostat show dmpnodename=c2t16d4s2
```

PATHNAME	OPERATIONS		BLOCKS		AVG TIME (ms)	
	READS	WRITES	READS	WRITES	READS	WRITES
c3t16d4s2	10	110	2	25	12.00	27.96
c2t17d4s2	20	126	4	29	9.50	19.41

You can now specify the units in which the statistics data is displayed. By default, the read/write times are displayed in milliseconds up to 2 decimal places. The throughput data is displayed in terms of 'BLOCKS' and the output is scaled, meaning that the small values are displayed in small units and the larger values are displayed in bigger units, keeping significant digits constant. The `-u` option accepts the following options:

k	Displays throughput in kiloblocks.
m	Displays throughput in megablocks.
g	Displays throughput in gigablocks.
bytes	Displays throughput in exact number of bytes.
us	Displays average read/write time in microseconds.

For example: To display average read/write times in microseconds.

```
# vxddmpadm -u us iostat show pathname=c2t17d4s2
```

PATHNAME	OPERATIONS		BLOCKS		AVG TIME (microsec)	
	READS	WRITES	READS	WRITES	READS	WRITES
c2t17d4s2	20	126	4	29	9500.00	19413.79

## Setting the attributes of the paths to an enclosure

You can use the `vxddmpadm setattr` command to set the attributes of the paths to an enclosure or disk array.

You can set the following attributes:

<code>active</code>	Changes a standby (failover) path to an active path. The following example specifies an active path for an A/P-C disk array:  <pre># vxddmpadm setattr path c2t10d0s2 pathtype=active</pre>
<code>nomannual</code>	Restores the original primary or secondary attributes of a path. This example restores the attributes for a path to an A/P disk array:  <pre># vxddmpadm setattr path c3t10d0s2 \   pathtype=nomannual</pre>
<code>nopreferred</code>	Restores the normal priority of a path. The following example restores the default priority to a path:  <pre># vxddmpadm setattr path c1t20d0s2 \   pathtype=nopreferred</pre>

preferred  
[priority=N]

Specifies a path as preferred, and optionally assigns a priority number to it. If specified, the priority number must be an integer that is greater than or equal to one. Higher priority numbers indicate that a path is able to carry a greater I/O load.

See “Specifying the I/O policy” on page 200.

This example first sets the I/O policy to `priority` for an Active/Active disk array, and then specifies a preferred path with an assigned priority of 2:

```
# vxddmadm setattr enclosure enc0 \  
  iopolicy=priority  
# vxddmadm setattr path c1t20d0s2 \  
  pathtype=preferred priority=2
```

primary

Defines a path as being the primary path for a JBOD disk array. The following example specifies a primary path for a JBOD disk array:

```
# vxddmadm setattr path c3t10d0s2 \  
  pathtype=primary
```

secondary

Defines a path as being the secondary path for a JBOD disk array. The following example specifies a secondary path for a JBOD disk array:

```
# vxddmadm setattr path c4t10d0s2 \  
  pathtype=secondary
```

standby

Marks a standby (failover) path that it is not used for normal I/O scheduling. This path is used if there are no active paths available for I/O. The next example specifies a standby path for an A/P-C disk array:

```
# vxddmadm setattr path c2t10d0s2 \  
  pathtype=standby
```

## Displaying the redundancy level of a device or enclosure

Use the `vxddmadm getdmpnode` command to list the devices with less than the required redundancy level.

To list the devices on a specified enclosure with fewer than a given number of active paths, use the following command:

```
# vxddmpadm getdmpnode enclosure=encl_name redundancy=value
```

For example, to list the devices with fewer than 3 active paths, use the following command:

```
# vxddmpadm getdmpnode enclosure=EMC_CLARiiON0 redundancy=3
```

NAME	STATE	ENCLR-TYPE	PATHS	ENBL	DSBL	ENCLR-NAME
emc_clariion0_162	ENABLED	EMC_CLARiiON	6	5	1	emc_clariion0
emc_clariion0_182	ENABLED	EMC_CLARiiON	6	6	0	emc_clariion0
emc_clariion0_184	ENABLED	EMC_CLARiiON	6	6	0	emc_clariion0
emc_clariion0_186	ENABLED	EMC_CLARiiON	6	6	0	emc_clariion0

To display the minimum redundancy level for a particular device, use the `vxddmpadm getattr` command, as follows:

```
# vxddmpadm getattr enclosure|arrayname|arraytype component-name redundancy
```

For example, to show the minimum redundancy level for the enclosure HDS9500-ALUA0:

```
# vxddmpadm getattr enclosure HDS9500-ALUA0 redundancy
```

ENCLR_NAME	DEFAULT	CURRENT
HDS9500-ALUA0	0	4

## Specifying the minimum number of active paths

You can set the minimum redundancy level for a device or an enclosure. The minimum redundancy level is the minimum number of paths that should be active for the device or the enclosure. If the number of paths falls below the minimum redundancy level for the enclosure, a message is sent to the system console and also logged to the DMP log file. Also, notification is sent to `vxnotify` clients.

The value set for minimum redundancy level is stored in the `dmppolicy.info` file, and is persistent. If no minimum redundancy level is set, the default value is 0.

You can use the `vxddmpadm setattr` command to set the minimum redundancy level.

### To specify the minimum number of active paths

- ◆ Use the `vxddmpadm setattr` command with the `redundancy` attribute as follows:

```
# vxddmpadm setattr enclosure|arrayname|arraytype component-name
  redundancy=value
```

where *value* is the number of active paths.

For example, to set the minimum redundancy level for the enclosure HDS9500-ALUA0:

```
# vxddmpadm setattr enclosure HDS9500-ALUA0 redundancy=2
```

## Displaying the I/O policy

To display the current and default settings of the I/O policy for an enclosure, array or array type, use the `vxddmpadm getattr` command.

The following example displays the default and current setting of `iopolicy` for JBOD disks:

```
# vxddmpadm getattr enclosure Disk iopolicy
```

ENCLR_NAME	DEFAULT	CURRENT
Disk	MinimumQ	Balanced

The next example displays the setting of `partitionsize` for the enclosure `enc0`, on which the `balanced` I/O policy with a partition size of 2MB has been set:

```
# vxddmpadm getattr enclosure enc0 partitionsize
```

ENCLR_NAME	DEFAULT	CURRENT
enc0	512	4096

## Specifying the I/O policy

You can use the `vxddmpadm setattr` command to change the I/O policy for distributing I/O load across multiple paths to a disk array or enclosure. You can set policies for an enclosure (for example, `HDS01`), for all enclosures of a particular type (such as `HDS`), or for all enclosures of a particular array type (such as `A/A` for Active/Active, or `A/P` for Active/Passive).



---

**Warning:** Starting with release 4.1 of VxVM, I/O policies are recorded in the file `/etc/vx/dmppolicy.info`, and are persistent across reboots of the system.

Do not edit this file yourself.

---

The following policies may be set:

`adaptive` This policy attempts to maximize overall I/O throughput from/to the disks by dynamically scheduling I/O on the paths. It is suggested for use where I/O loads can vary over time. For example, I/O from/to a database may exhibit both long transfers (table scans) and short transfers (random look ups). The policy is also useful for a SAN environment where different paths may have different number of hops. No further configuration is possible as this policy is automatically managed by DMP.

In this example, the adaptive I/O policy is set for the enclosure `encl1`:

```
# vxdkmpadm setattr enclosure encl1 \  
  iopolicy=adaptive
```

balanced  
[partitionsize=size]

This policy is designed to optimize the use of caching in disk drives and RAID controllers. The size of the cache typically ranges from 120KB to 500KB or more, depending on the characteristics of the particular hardware. During normal operation, the disks (or LUNs) are logically divided into a number of regions (or partitions), and I/O from/to a given region is sent on only one of the active paths. Should that path fail, the workload is automatically redistributed across the remaining paths.

You can use the size argument to the partitionsize attribute to specify the partition size. The partition size in blocks is adjustable in powers of 2 from 2 up to 231. A value that is not a power of 2 is silently rounded down to the nearest acceptable value.

Specifying a partition size of 0 is equivalent to specifying the default partition size.

The default value for the partition size is 512 blocks (256k). Specifying a partition size of 0 is equivalent to the default partition size of 512 blocks (256k).

The default value can be changed by adjusting the value of the `dmp_pathswitch_blks_shift` tunable parameter.

See “[DMP tunable parameters](#)” on page 566.

**Note:** The benefit of this policy is lost if the value is set larger than the cache size.

For example, the suggested partition size for an Hitachi HDS 9960 A/A array is from 32,768 to 131,072 blocks (16MB to 64MB) for an I/O activity pattern that consists mostly of sequential reads or writes.

The next example sets the balanced I/O policy with a partition size of 4096 blocks (2MB) on the enclosure enc0:

```
# vxddmpadm setattr enclosure enc0 \  
  iopolicy=balanced partitionsize=4096
```

minimumq

This policy sends I/O on paths that have the minimum number of outstanding I/O requests in the queue for a LUN. No further configuration is possible as DMP automatically determines the path with the shortest queue.

The following example sets the I/O policy to `minimumq` for a JBOD:

```
# vxddmpadm setattr enclosure Disk \  
  iopolicy=minimumq
```

This is the default I/O policy for all arrays.

`priority` This policy is useful when the paths in a SAN have unequal performance, and you want to enforce load balancing manually. You can assign priorities to each path based on your knowledge of the configuration and performance characteristics of the available paths, and of other aspects of your system.

See [“Setting the attributes of the paths to an enclosure”](#) on page 197.

In this example, the I/O policy is set to `priority` for all SENA arrays:

```
# vxddmpadm setattr arrayname SENA \  
  iopolicy=priority
```

`round-robin` This policy shares I/O equally between the paths in a round-robin sequence. For example, if there are three paths, the first I/O request would use one path, the second would use a different path, the third would be sent down the remaining path, the fourth would go down the first path, and so on. No further configuration is possible as this policy is automatically managed by DMP.

The next example sets the I/O policy to `round-robin` for all Active/Active arrays:

```
# vxddmpadm setattr arraytype A/A \  
  iopolicy=round-robin
```

`singleactive` This policy routes I/O down the single active path. This policy can be configured for A/P arrays with one active path per controller, where the other paths are used in case of failover. If configured for A/A arrays, there is no load balancing across the paths, and the alternate paths are only used to provide high availability (HA). If the current active path fails, I/O is switched to an alternate active path. No further configuration is possible as the single active path is selected by DMP.

The following example sets the I/O policy to `singleactive` for JBOD disks:

```
# vxddmpadm setattr arrayname Disk \  
  iopolicy=singleactive
```

## Scheduling I/O on the paths of an Asymmetric Active/Active array

You can specify the `use_all_paths` attribute in conjunction with the `adaptive`, `balanced`, `minimumq`, `priority` and `round-robin` I/O policies to specify whether I/O requests are to be scheduled on the secondary paths in addition to the primary paths of an Asymmetric Active/Active (A/A-A) array. Depending on the

characteristics of the array, the consequent improved load balancing can increase the total I/O throughput. However, this feature should only be enabled if recommended by the array vendor. It has no effect for array types other than A/A-A.

For example, the following command sets the `balanced` I/O policy with a partition size of 4096 blocks (2MB) on the enclosure `enc0`, and allows scheduling of I/O requests on the secondary paths:

```
# vxddmpadm setattr enclosure enc0 iopolicy=balanced \  
    partitionsize=4096 use_all_paths=yes
```

The default setting for this attribute is `use_all_paths=no`.

You can display the current setting for `use_all_paths` for an enclosure, arrayname or arraytype. To do this, specify the `use_all_paths` option to the `vxddmpadm gettattr` command.

```
# vxddmpadm gettattr enclosure HDS9500-ALUA0 use_all_paths
```

```
ENCLR_NAME  DEFAULT  CURRENT  
=====
```

ENCLR_NAME	DEFAULT	CURRENT
HDS9500-ALUA0	no	yes

The `use_all_paths` attribute only applies to A/A-A arrays. For other arrays, the above command displays the message:

```
Attribute is not applicable for this array.
```

## Example of applying load balancing in a SAN

This example describes how to configure load balancing in a SAN environment where there are multiple primary paths to an Active/Passive device through several SAN switches. As can be seen in this sample output from the `vxddisk list` command, the device `c3t2d15s2` has eight primary paths:

```
# vxddisk list c3t2d15s2
```

```
Device: c3t2d15s2  
.  
.  
.  
numpaths: 8  
c2t0d15s2 state=enabled type=primary  
c2t1d15s2 state=enabled type=primary  
c3t1d15s2 state=enabled type=primary
```

```

c3t2d15s2 state=enabled type=primary
c4t2d15s2 state=enabled type=primary
c4t3d15s2 state=enabled type=primary
c5t3d15s2 state=enabled type=primary
c5t4d15s2 state=enabled type=primary

```

In addition, the device is in the enclosure `ENC0`, belongs to the disk group `mydg`, and contains a simple concatenated volume `myvol1`.

The first step is to enable the gathering of DMP statistics:

```
# vxddpadm iostat start
```

Next the `dd` command is used to apply an input workload from the volume:

```
# dd if=/dev/vx/rdisk/mydg/myvol1 of=/dev/null &
```

By running the `vxddpadm iostat` command to display the DMP statistics for the device, it can be seen that all I/O is being directed to one path, `c5t4d15s2`:

```
# vxddpadm iostat show dmpnodename=c3t2d15s2 interval=5 count=2
```

```

.
.
.
cpu usage = 11294us per cpu memory = 32768b

```

PATHNAME	OPERATIONS		KBYTES		AVG TIME (ms)	
	READS	WRITES	READS	WRITES	READS	WRITES
c2t0d15s2	0	0	0	0	0.00	0.00
c2t1d15s2	0	0	0	0	0.00	0.00
c3t1d15s2	0	0	0	0	0.00	0.00
c3t2d15s2	0	0	0	0	0.00	0.00
c4t2d15s2	0	0	0	0	0.00	0.00
c4t3d15s2	0	0	0	0	0.00	0.00
c5t3d15s2	0	0	0	0	0.00	0.00
c5t4d15s2	10986	0	5493	0	0.41	0.00

The `vxddpadm` command is used to display the I/O policy for the enclosure that contains the device:

```
# vxddpadm getattr enclosure ENC0 iopolicy
```

```

ENCLR_NAME          DEFAULT          CURRENT
=====
ENC0                 Round-Robin     Single-Active

```

This shows that the policy for the enclosure is set to `singleactive`, which explains why all the I/O is taking place on one path.

To balance the I/O load across the multiple primary paths, the policy is set to `round-robin` as shown here:

```
# vxddmpadm setattr enclosure ENC0 iopolicy=round-robin
# vxddmpadm getattr enclosure ENC0 iopolicy
```

```
ENCLR_NAME      DEFAULT          CURRENT
=====
ENC0            Round-Robin     Round-Robin
```

The DMP statistics are now reset:

```
# vxddmpadm iostat reset
```

With the workload still running, the effect of changing the I/O policy to balance the load across the primary paths can now be seen.

```
# vxddmpadm iostat show dmpnodename=c3t2d15s2 interval=5 count=2
```

```
.
.
.
cpu usage = 14403us per cpu memory = 32768b
```

PATHNAME	OPERATIONS		KBYTES		AVG TIME (ms)	
	READS	WRITES	READS	WRITES	READS	WRITES
c2t0d15s2	2041	0	1021	0	0.39	0.00
c2t1d15s2	1894	0	947	0	0.39	0.00
c3t1d15s2	2008	0	1004	0	0.39	0.00
c3t2d15s2	2054	0	1027	0	0.40	0.00
c4t2d15s2	2171	0	1086	0	0.39	0.00
c4t3d15s2	2095	0	1048	0	0.39	0.00
c5t3d15s2	2073	0	1036	0	0.39	0.00
c5t4d15s2	2042	0	1021	0	0.39	0.00

The enclosure can be returned to the single active I/O policy by entering the following command:

```
# vxddmpadm setattr enclosure ENC0 iopolicy=singleactive
```

## Disabling I/O for paths, controllers or array ports

Disabling I/O through a path, HBA controller or array port prevents DMP from issuing I/O requests through the specified path, or the paths that are connected

to the specified controller or array port. The command blocks until all pending I/O requests issued through the paths are completed.

---

**Note:** From release 5.0 of VxVM, this operation is supported for controllers that are used to access disk arrays on which cluster-shareable disk groups are configured.

---

Before detaching a system board, stop all I/O to the HBA controllers that are located on the board. To do this, execute the `vxddmpadm disable` command, and then run the Dynamic Reconfiguration (DR) facility provided by Sun.

To disable I/O for a path, use the following command:

```
# vxddmpadm [-c|-f] disable path=path_name
```

To disable I/O for multiple paths, use the following command:

```
# vxddmpadm [-c|-f] disable path=path_name1,path_name2,path_nameN
```

To disable I/O for the paths connected to an HBA controller, use the following command:

```
# vxddmpadm [-c|-f] disable ctrl=ctrl_name
```

To disable I/O for the paths connected to an array port, use one of the following commands:

```
# vxddmpadm [-c|-f] disable enclosure=enclr_name portid=array_port_ID  
# vxddmpadm [-c|-f] disable pwwn=array_port_WWN
```

where the array port is specified either by the enclosure name and the array port ID, or by the array port's worldwide name (WWN) identifier.

The following are examples of using the command to disable I/O on an array port:

```
# vxddmpadm disable enclosure=HDS9500V0 portid=1A  
# vxddmpadm disable pwwn=20:00:00:E0:8B:06:5F:19
```

You can use the `-c` option to check if there is only a single active path to the disk. If so, the `disable` command fails with an error message unless you use the `-f` option to forcibly disable the path.

The `disable` operation fails if it is issued to a controller that is connected to the root disk through a single path, and there are no root disk mirrors configured on alternate paths. If such mirrors exist, the command succeeds.

## Enabling I/O for paths, controllers or array ports

Enabling a controller allows a previously disabled path, HBA controller or array port to accept I/O again. This operation succeeds only if the path, controller or array port is accessible to the host, and I/O can be performed on it. When connecting Active/Passive disk arrays, the `enable` operation results in failback of I/O to the primary path. The `enable` operation can also be used to allow I/O to the controllers on a system board that was previously detached.

---

**Note:** From release 5.0 of VxVM, this operation is supported for controllers that are used to access disk arrays on which cluster-shareable disk groups are configured.

---

To enable I/O for a path, use the following command:

```
# vxddm enable path=path_name
```

To enable I/O for multiple paths, use the following command:

```
# vxddm enable path=path_name1,path_name2,path_nameN
```

To enable I/O for the paths connected to an HBA controller, use the following command:

```
# vxddm enable ctrl=ctrl_name
```

To enable I/O for the paths connected to an array port, use one of the following commands:

```
# vxddm enable enclosure=enclr_name portid=array_port_ID  
# vxddm [-f] enable pwn=array_port_WWN
```

where the array port is specified either by the enclosure name and the array port ID, or by the array port's worldwide name (WWN) identifier.

The following are examples of using the command to enable I/O on an array port:

```
# vxddm enable enclosure=HDS9500V0 portid=1A  
# vxddm enable pwn=20:00:00:E0:8B:06:5F:19
```

## Upgrading disk controller firmware

You can upgrade disk controller firmware without performing a system reboot or unloading the VxVM drivers.



First obtain the appropriate firmware upgrades from your disk drive vendor. You can usually download the appropriate files and documentation from the vendor's support website.

#### To upgrade the disk controller firmware

- 1 Disable the plex that is associated with the disk device:

```
# /opt/VRTS/bin/vxplex -g diskgroup det plex
```

(The example is a volume mirrored across 2 controllers on one HBA.)

- 2 Stop I/O to all disks through one controller of the HBA:

```
# /opt/VRTS/bin/vxdmpadm disable ctrl=first_cntlr
```

For the other controller on the HBA, enter:

```
# /opt/VRTS/bin/vxdmpadm -f disable ctrl=second_cntlr
```

- 3 Upgrade the firmware on those disks for which the controllers have been disabled using the procedures that you obtained from the disk drive vendor.
- 4 After doing the upgrade, re-enable all the controllers:

```
# /opt/VRTS/bin/vxdmpadm enable ctrl=first_cntlr  
# /opt/VRTS/bin/vxdmpadm enable ctrl=second_cntlr
```

- 5 Re-enable the plex associated with the device:

```
# /opt/VRTS/bin/vxplex -g diskgroup att volume plex
```

This command takes some time depending upon the size of the mirror set.

## Renaming an enclosure

The `vxmpadm setattr` command can be used to assign a meaningful name to an existing enclosure, for example:

```
# vxmpadm setattr enclosure enc0 name=GRP1
```

This example changes the name of an enclosure from `enc0` to `GRP1`.

---

**Note:** The maximum length of the enclosure name prefix is 25 characters.

---

The following command shows the changed name:

```
# vxddmpadm listenclosure all
```

ENCLR_NAME	ENCLR_TYPE	ENCLR_SNO	STATUS
other0	OTHER	OTHER_DISKS	CONNECTED
jbod0	X1	X1_DISKS	CONNECTED
GRP1	ACME	60020f20000001a90000	CONNECTED

## Configuring the response to I/O failures

You can configure how DMP responds to failed I/O requests on the paths to a specified enclosure, disk array name, or type of array. By default, DMP is configured to retry a failed I/O request up to 5 times for a single path.

To display the current settings for handling I/O request failures that are applied to the paths to an enclosure, array name or array type, use the `vxddmpadm getattr` command.

See [“Displaying recovery option values”](#) on page 213.

To set a limit for the number of times that DMP attempts to retry sending an I/O request on a path, use the following command:

```
# vxddmpadm setattr \  
  {enclosure enc-name|arrayname name|arraytype type} \  
  recoveryoption=fixedretry retrycount=n
```

The value of the argument to `retrycount` specifies the number of retries to be attempted before DMP reschedules the I/O request on another available path, or fails the request altogether.

As an alternative to specifying a fixed number of retries, the following version of the command specifies how long DMP should allow an I/O request to be retried on a path:

```
# vxddmpadm setattr \  
  {enclosure enc-name|arrayname name|arraytype type} \  
  recoveryoption=timebound iotimeout=seconds
```

The value of the argument to `iotimeout` specifies the time in seconds that DMP waits for an outstanding I/O request to succeed before it reschedules the request on another available path, or fails the I/O request altogether. The effective number of retries is the value of `iotimeout` divided by the sum of the times taken for each retry attempt. DMP abandons retrying to send the I/O request before the specified time limit has expired if it predicts that the next retry will take the total elapsed time over this limit.

The default value of `iotimeout` is 10 seconds. For some applications, such as Oracle, it may be desirable to set `iotimeout` to a larger value, such as 60 seconds.

---

**Note:** The `fixedretry` and `timebound` settings are mutually exclusive.

---

The following example configures time-bound recovery for the enclosure `enc0`, and sets the value of `iotimeout` to 60 seconds:

```
# vxddmpadm setattr enclosure enc0 recoveryoption=timebound \  
    iotimeout=60
```

The next example sets a fixed-retry limit of 10 for the paths to all Active/Active arrays:

```
# vxddmpadm setattr arraytype A/A recoveryoption=fixedretry \  
    retrycount=10
```

Specifying `recoveryoption=default` resets DMP to the default settings corresponding to `recoveryoption=fixedretry retrycount=5`, for example:

```
# vxddmpadm setattr arraytype A/A recoveryoption=default
```

The above command also has the effect of configuring I/O throttling with the default settings.

See [“Configuring the I/O throttling mechanism”](#) on page 211.

---

**Note:** The response to I/O failure settings is persistent across reboots of the system.

---

## Configuring the I/O throttling mechanism

By default, DMP is configured with I/O throttling turned off for all paths. To display the current settings for I/O throttling that are applied to the paths to an enclosure, array name or array type, use the `vxddmpadm getattr` command.

See [“Displaying recovery option values”](#) on page 213.

If enabled, I/O throttling imposes a small overhead on CPU and memory usage because of the activity of the statistics-gathering daemon. If I/O throttling is disabled, the daemon no longer collects statistics, and remains inactive until I/O throttling is re-enabled.

To turn off I/O throttling, use the following form of the `vxddmpadm setattr` command:

```
# vxddmpadm setattr \  
  {enclosure enc-name|arrayname name|arraytype type} \  
  recoveryoption=nothrottle
```

The following example shows how to disable I/O throttling for the paths to the enclosure `enc0`:

```
# vxddmpadm setattr enclosure enc0 recoveryoption=nothrottle
```

The `vxddmpadm setattr` command can be used to enable I/O throttling on the paths to a specified enclosure, disk array name, or type of array:

```
# vxddmpadm setattr \  
  {enclosure enc-name|arrayname name|arraytype type}\  
  recoveryoption=throttle {iotimeout=seconds|queuedepth=n}
```

If the `iotimeout` attribute is specified, its argument specifies the time in seconds that DMP waits for an outstanding I/O request to succeed before invoking I/O throttling on the path. The default value of `iotimeout` is 10 seconds. Setting `iotimeout` to a larger value potentially causes more I/O requests to become queued up in the SCSI driver before I/O throttling is invoked.

If the `queuedepth` attribute is specified, its argument specifies the number of I/O requests that can be outstanding on a path before DMP invokes I/O throttling. The default value of `queuedepth` is 20. Setting `queuedepth` to a larger value allows more I/O requests to become queued up in the SCSI driver before I/O throttling is invoked.

---

**Note:** The `iotimeout` and `queuedepth` attributes are mutually exclusive.

---

The following example sets the value of `iotimeout` to 60 seconds for the enclosure `enc0`:

```
# vxddmpadm setattr enclosure enc0 recoveryoption=throttle \  
  iotimeout=60
```

The next example sets the value of `queuedepth` to 30 for the paths to all Active/Active arrays:

```
# vxddmpadm setattr arraytype A/A recoveryoption=throttle \  
  queuedepth=30
```

Specify `recoveryoption=default` to reset I/O throttling to the default settings, as follows:

```
# vxddmpadm setattr arraytype A/A recoveryoption=default
```

The above command configures the default behavior, corresponding to `recoveryoption=nothrottle`. The above command also configures the default behavior for the response to I/O failures.

See [“Configuring the response to I/O failures”](#) on page 210.

---

**Note:** The I/O throttling settings are persistent across reboots of the system.

---

## Displaying recovery option values

To display the current settings for handling I/O request failures that are applied to the paths to an enclosure, array name or array type, use the following command:

```
# vxddmpadm getattr \  
  {enclosure enc-name|arrayname name|arraytype type} \  
  recoveryoption
```

The following example shows the `vxddmpadm getattr` command being used to display the `recoveryoption` option values that are set on an enclosure.

```
# vxddmpadm getattr enclosure HDS9500-ALUA0 recoveryoption  
ENCLR-NAME      RECOVERY-OPTION  DEFAULT [VAL]    CURRENT [VAL]  
=====   
HDS9500-ALUA0  Throttle         Nothrottle[0]   Queuedepth[60]  
HDS9500-ALUA0  Error-Retry      Fixed-Retry[5]  Timebound[20]
```

This shows the default and current policy options and their values.

[Table 4-1](#) summarizes the possible recovery option settings for retrying I/O after an error.

**Table 4-1** Recovery options for retrying I/O after an error

Recovery option	Possible settings	Description
<code>recoveryoption=fixedretry</code>	Fixed-Retry (retrycount)	DMP retries a failed I/O request for the specified number of times if I/O fails.
<code>recoveryoption=timebound</code>	Timebound (iotimeout)	DMP retries a failed I/O request for the specified time in seconds if I/O fails.

[Table 4-2](#) summarizes the possible recovery option settings for throttling I/O.

**Table 4-2** Recovery options for I/O throttling

Recovery option	Possible settings	Description
recoveryoption=nothrottle	None	I/O throttling is not used.
recoveryoption=throttle	Queuedepth (queuedepth)	DMP throttles the path if the specified number of queued I/O requests is exceeded.
recoveryoption=throttle	Timebound (iotimeout)	DMP throttles the path if an I/O request does not return within the specified time in seconds.

## Configuring DMP path restoration policies

DMP maintains a kernel thread that re-examines the condition of paths at a specified interval. The type of analysis that is performed on the paths depends on the checking policy that is configured.

---

**Note:** The DMP path restoration thread does not change the disabled state of the path through a controller that you have disabled using `vxddpdm disable`.

---

When configuring DMP path restoration policies, you must stop the path restoration thread, and then restart it with new attributes.

See “[Stopping the DMP path restoration thread](#)” on page 216.

Use the `vxddpdm start restore` command to configure one of the following restore policies. The policy will remain in effect until the restore thread is stopped or the values are changed using `vxddpdm settune` command.

- `check_all`

The path restoration thread analyzes all paths in the system and revives the paths that are back online, as well as disabling the paths that are inaccessible. The command to configure this policy is:

```
# vxddpdm start restore [interval=seconds] policy=check_all
```

- `check_alterate`

The path restoration thread checks that at least one alternate path is healthy. It generates a notification if this condition is not met. This policy avoids inquiry commands on all healthy paths, and is less costly than `check_all` in cases where a large number of paths are available. This policy is the same as

`check_all` if there are only two paths per DMP node. The command to configure this policy is:

```
# vxddmpadm start restore [interval=seconds] \  
policy=check_alterate
```

■ `check_disabled`

This is the default path restoration policy. The path restoration thread checks the condition of paths that were previously disabled due to hardware failures, and revives them if they are back online. The command to configure this policy is:

```
# vxddmpadm start restore [interval=seconds] \  
policy=check_disabled
```

■ `check_periodic`

The path restoration thread performs `check_all` once in a given number of cycles, and `check_disabled` in the remainder of the cycles. This policy may lead to periodic slowing down (due to `check_all`) if there is a large number of paths available. The command to configure this policy is:

```
# vxddmpadm start restore interval=seconds \  
policy=check_periodic [period=number]
```

The `interval` attribute must be specified for this policy. The default number of cycles between running the `check_all` policy is 10.

The `interval` attribute specifies how often the path restoration thread examines the paths. For example, after stopping the path restoration thread, the polling interval can be set to 400 seconds using the following command:

```
# vxddmpadm start restore interval=400
```

Starting with the 5.0MP3 release, you can also use the `vxddmpadm settune` command to change the restore policy, restore interval, and restore period. This method stores the values for these arguments as DMP tunables. The settings are immediately applied and are persistent across reboots. Use the `vxddmpadm gettune` to view the current settings.

See “[DMP tunable parameters](#)” on page 566.

If the `vxddmpadm start restore` command is given without specifying a policy or interval, the path restoration thread is started with the persistent policy and interval settings previously set by the administrator with the `vxddmpadm settune` command. If the administrator has not set a policy or interval, the system defaults

are used. The system default restore policy is `check_disabled`. The system default interval is 300 seconds.

---

**Warning:** Decreasing the interval below the system default can adversely affect system performance.

---

## Stopping the DMP path restoration thread

Use the following command to stop the DMP path restoration thread:

```
# vxddpdm stop restore
```

---

**Warning:** Automatic path failback stops if the path restoration thread is stopped.

---

## Displaying the status of the DMP path restoration thread

Use the following command to display the status of the automatic path restoration kernel thread, its polling interval, and the policy that it uses to check the condition of paths:

```
# vxddpdm stat restored
```

This produces output such as the following:

```
The number of daemons running : 1
The interval of daemon: 300
The policy of daemon: check_disabled
```

## Displaying information about the DMP error-handling thread

To display information about the kernel thread that handles DMP errors, use the following command:

```
# vxddpdm stat error
```

One daemon should be shown as running.

## Configuring array policy modules

An array policy module (APM) is a dynamically loadable kernel module (plug-in for DMP) for use in conjunction with an array. An APM defines array-specific procedures and commands to:

- Select an I/O path when multiple paths to a disk within the array are available.



- Select the path failover mechanism.
- Select the alternate path in the case of a path failure.
- Put a path change into effect.
- Respond to SCSI reservation or release requests.

DMP supplies default procedures for these functions when an array is registered. An APM may modify some or all of the existing procedures that are provided by DMP or by another version of the APM.

You can use the following command to display all the APMs that are configured for a system:

```
# vxddpdm listapm all
```

The output from this command includes the file name of each module, the supported array type, the APM name, the APM version, and whether the module is currently loaded and in use. To see detailed information for an individual module, specify the module name as the argument to the command:

```
# vxddpdm listapm module_name
```

To add and configure an APM, use the following command:

```
# vxddpdm -a cfgapm module_name [attr1=value1 \  
    [attr2=value2 ...]]
```

The optional configuration attributes and their values are specific to the APM for an array. Consult the documentation that is provided by the array vendor for details.

---

**Note:** By default, DMP uses the most recent APM that is available. Specify the `-u` option instead of the `-a` option if you want to force DMP to use an earlier version of the APM. The current version of an APM is replaced only if it is not in use.

---

Specifying the `-r` option allows you to remove an APM that is not currently loaded:

```
# vxddpdm -r cfgapm module_name
```

See the `vxddpdm(1M)` manual page.



# Creating and administering disk groups

This chapter includes the following topics:

- [About disk groups](#)
- [Displaying disk group information](#)
- [Creating a disk group](#)
- [Adding a disk to a disk group](#)
- [Removing a disk from a disk group](#)
- [Moving disks between disk groups](#)
- [Deporting a disk group](#)
- [Importing a disk group](#)
- [Handling of minor number conflicts](#)
- [Moving disk groups between systems](#)
- [Handling cloned disks with duplicated identifiers](#)
- [Renaming a disk group](#)
- [Handling conflicting configuration copies](#)
- [Reorganizing the contents of disk groups](#)
- [Disabling a disk group](#)
- [Destroying a disk group](#)

- [Upgrading a disk group](#)
- [Managing the configuration daemon in VxVM](#)
- [Backing up and restoring disk group configuration data](#)
- [Using vxnotify to monitor configuration changes](#)
- [Working with ISP disk groups](#)

## About disk groups

Disk groups are named collections of disks that share a common configuration. Volumes are created within a disk group and are restricted to using disks within that disk group.

Data related to a particular set of applications or a particular group of users may need to be made accessible on another system. These situations include the following:

- A system has failed and its data needs to be moved to other systems.
- The work load must be balanced across a number of systems.

You must place disks in one or more disk groups before VxVM can use the disks for volumes. It is important that you locate data related to particular applications or users on an identifiable set of disks. When you need to move these disks, this lets you move only the application or user data that should be moved. The disk group also provides a single object to move, rather than specifying all objects within the disk group individually.

As system administrator, you can create additional disk groups to arrange your system's disks for different purposes. Many systems only use one disk group, unless they have a large number of disks. You can initialize, reserve, and add disks to disk groups at any time. You do not have to add disks to disk groups until the disks are needed to create VxVM objects.

Veritas Volume Manager's Cross-platform Data Sharing (CDS) feature lets you move VxVM disks and objects between machines that are running under different operating systems. Disk groups may be made compatible with CDS.

See the *Veritas Storage Foundation Cross-Platform Data Sharing Administrator's Guide*.

When you add a disk to a disk group, you name that disk (for example, `mydg02`). This name identifies a disk for operations such as creating or mirroring a volume. The name also relates directly to the underlying physical disk. If a physical disk is moved to a different target address or to a different controller, the name `mydg02`

continues to refer to it. You can replace disks by first associating a different physical disk with the name of the disk to be replaced and then recovering any volume data that was stored on the original disk (from mirrors or backup copies).

Having disk groups that contain many disks and VxVM objects causes the private region to fill. If you have large disk groups that are expected to contain more than several hundred disks and VxVM objects, you should set up disks with larger private areas. A major portion of a private region provides space for a disk group configuration database that contains records for each VxVM object in that disk group. Because each configuration record is approximately 256 bytes, you can use the configuration database copy size to estimate the number of records that you can create in a disk group. You can obtain the copy size in blocks from the output of the `vx dg list diskgroup` command. It is the value of the `permlen` parameter on the line starting with the string `"config:"`. This value is the smallest of the `len` values for all copies of the configuration database in the disk group. The value of the `free` parameter indicates the amount of remaining free space in the configuration database.

See ["Displaying disk group information"](#) on page 224.

One way to overcome the problem of running out of free space is to split the affected disk group into two separate disk groups.

See ["Reorganizing the contents of disk groups"](#) on page 256.

See ["Backing up and restoring disk group configuration data"](#) on page 276.

Before Veritas Volume Manager (VxVM) 4.0, a system installed with VxVM was configured with a default disk group, `rootdg`. This group had to contain at least one disk. By default, operations were directed to the `rootdg` disk group. From release 4.0 onward, VxVM can function without any disk group having been configured. Only when the first disk is placed under VxVM control must a disk group be configured. Now, you do not have to name any disk group `rootdg`. If you name a disk group `rootdg`, it has no special properties because of this name.

See ["Specification of disk groups to commands"](#) on page 222.

---

**Note:** Most VxVM commands require superuser or equivalent privileges.

---

Additionally, before VxVM 4.0, some commands such as `vx disk` were able to deduce the disk group if the name of an object was uniquely defined in one disk group among all the imported disk groups. Resolution of a disk group in this way is no longer supported for any command.

## Specification of disk groups to commands

Many VxVM commands let you specify a disk group using the `-g` option. For example, the following command creates a volume in the disk group, `mkt dg`:

```
# vxassist -g mkt dg make mkt vol 5g
```

The block special device that corresponds to this volume is  
`/dev/vx/dsk/mkt dg/mkt vol`.

## System-wide reserved disk groups

The following disk group names are reserved, and cannot be used to name any disk groups that you create:

<code>boot dg</code>	Specifies the boot disk group. This is an alias for the disk group that contains the volumes that are used to boot the system. VxVM sets <code>boot dg</code> to the appropriate disk group if it takes control of the root disk. Otherwise, <code>boot dg</code> is set to <code>nodg</code> (no disk group).
<code>default dg</code>	Specifies the default disk group. This is an alias for the disk group name that should be assumed if the <code>-g</code> option is not specified to a command, or if the <code>VXVM_DEFAULT DG</code> environment variable is undefined. By default, <code>default dg</code> is set to <code>nodg</code> (no disk group).
<code>nodg</code>	Specifies to an operation that no disk group has been defined. For example, if the root disk is not under VxVM control, <code>boot dg</code> is set to <code>nodg</code> .

---

**Warning:** Do not try to change the assigned value of `boot dg`. If you change the value, it may render your system unbootable.

---

If you have upgraded your system, you may find it convenient to continue to configure a disk group named `root dg` as the default disk group (`default dg`). `default dg` and `boot dg` do not have to refer to the same disk group. Also, neither the default disk group nor the boot disk group have to be named `root dg`.

## Rules for determining the default disk group

You should use the `-g` option to specify a disk group to VxVM commands that accept this option. If you do not specify the disk group, VxVM applies rules in the following order until it determines a disk group name:

- Use the default disk group name that is specified by the environment variable `VXVM_DEFAULTDG`. This variable can also be set to one of the reserved system-wide disk group names: `bootdg`, `defaultdg`, or `nodg`. If the variable is undefined, the following rule is applied.
- Use the disk group that has been assigned to the system-wide default disk group alias, `defaultdg`. If this alias is undefined, the following rule is applied. See “[Displaying and specifying the system-wide default disk group](#)” on page 223.
- If the operation can be performed without requiring a disk group name (for example, an edit operation on disk access records), do so.

If none of these rules succeeds, the requested operation fails.

---

**Warning:** In releases of VxVM prior to 4.0, a subset of commands tried to determine the disk group by searching for the object name that was being operated upon by a command. This functionality is no longer supported. Scripts that rely on determining the disk group from an object name may fail.

---

## Displaying the system-wide boot disk group

To display the currently defined system-wide boot disk group, use the following command:

```
# vxdg bootdg
```

See the `vxdg(1M)` manual page.

## Displaying and specifying the system-wide default disk group

To display the currently defined system-wide default disk group, use the following command:

```
# vxdg defaultdg
```

If a default disk group has not been defined, `nodg` is displayed. You can also use the following command to display the default disk group:

```
# vxprint -Gng defaultdg 2>/dev/null
```

In this case, if there is no default disk group, nothing is displayed.

Use the following command to specify the name of the disk group that is aliased by `defaultdg`:

```
# vxdctl defaultdg diskgroup
```

If `bootdg` is specified as the argument to this command, the default disk group is set to be the same as the currently defined system-wide boot disk group.

If `nodg` is specified as the argument to the `vxdctl defaultdg` command, the default disk group is undefined.

The specified disk group is not required to exist on the system.

See the `vxdctl(1M)` manual page.

See the `vxdg(1M)` manual page.

## Displaying disk group information

To display information on existing disk groups, enter the following command:

```
# vxdg list
NAME      STATE      ID
rootdg    enabled    730344554.1025.tweety
newdg     enabled    731118794.1213.tweety
```

To display more detailed information on a specific disk group, use the following command:

```
# vxdg list diskgroup
```

When you apply this command to a disk group named `mydg`, the output is similar to the following:

```
# vxdg list mydg

Group: mydg
dgid: 962910960.1025.bass
import-id: 0.1
flags:
version: 140
local-activation: read-write
alignment: 512 (bytes)
ssb: on
detach-policy: local
copies: nconfig=default nlog=default
config: seqno=0.1183 permlen=3448 free=3428 templen=12 loglen=522
config disk c0t10d0 copy 1 len=3448 state=clean online
config disk c0t11d0 copy 1 len=3448 state=clean online
log disk c0t10d0 copy 1 len=522
log disk c0t11d0 copy 1 len=522
```



To verify the disk group ID and name that is associated with a specific disk (for example, to import the disk group), use the following command:

```
# vxdisk -s list devicename
```

This command provides output that includes the following information for the specified disk. For example, output for disk `c0t12d0` as follows:

```
Disk:    c0t12d0
type:    simple
flags:   online ready private autoconfig autoimport imported
diskid:  963504891.1070.bass
dgroup:  newdg
dgid:    963504895.1075.bass
hostid:  bass
info:    privoffset=128
```

## Displaying free space in a disk group

Before you add volumes and file systems to your system, make sure that you have enough free disk space to meet your needs.

To display free space in the system, use the following command:

```
# vxdg free
```

The following is example output:

GROUP	DISK	DEVICE	TAG	OFFSET	LENGTH	FLAGS
mydg	mydg01	c0t10d0	c0t10d0	0	4444228	-
mydg	mydg02	c0t11d0	c0t11d0	0	4443310	-
newdg	newdg01	c0t12d0	c0t12d0	0	4443310	-
newdg	newdg02	c0t13d0	c0t13d0	0	4443310	-
oradg	oradg01	c0t14d0	c0t14d0	0	4443310	-

To display free space for a disk group, use the following command:

```
# vxdg -g diskgroup free
```

where `-g diskgroup` optionally specifies a disk group.

For example, to display the free space in the disk group, `mydg`, use the following command:

```
# vxdg -g mydg free
```

The following example output shows the amount of free space in sectors:

DISK	DEVICE	TAG	OFFSET	LENGTH	FLAGS
mydg01	c0t10d0	c0t10d0	0	4444228	-
mydg02	c0t11d0	c0t11d0	0	4443310	-

## Creating a disk group

You must associate a disk group with at least one disk. You can create a new disk group when you select **Add or initialize one or more disks** from the main menu of the `vxdiskadm` command to add disks to VxVM control. The disks to be added to a disk group must not belong to an existing disk group.

You can also use the `vxdiskadd` command to create a new disk group:

```
# vxdiskadd c1t0d0
```

where `c1t0d0` is the device name of a disk that is not currently assigned to a disk group. The command dialog is similar to that described for the `vxdiskadm` command.

See [“Adding a disk to VxVM”](#) on page 115.

You can also create disk groups using following the `vx dg init` command:

```
# vx dg init diskgroup [cds=on|off] diskname=device name
```

For example, to create a disk group named `mkt dg` on device `c1t0d0s2`, enter the following:

```
# vx dg init mkt dg mkt dg01=c1t0d0s2
```

The disk that is specified by the device name, `c1t0d0s2`, must have been previously initialized with `vx diskadd` or `vx diskadm`. The disk must not currently belong to a disk group.

You can use the `cds` attribute with the `vx dg init` command to specify whether a new disk group is compatible with the Cross-platform Data Sharing (CDS) feature. In Veritas Volume Manager 4.0 and later releases, newly created disk groups are compatible with CDS by default (equivalent to specifying `cds=on`). If you want to change this behavior, edit the file `/etc/default/vx dg` and set the attribute-value pair `cds=off` in this file before creating a new disk group.

You can also use the following command to set this attribute for a disk group:

```
# vx dg -g diskgroup set cds=on|off
```

## Adding a disk to a disk group

To add a disk to an existing disk group, select `Add` or `initialize` one or more disks from the main menu of the `vxdiskadm` command.

You can also use the `vxdiskadd` command to add a disk to a disk group. Enter the following:

```
# vxdiskadd c1t1d0
```

where `c1t1d0` is the device name of a disk that is not currently assigned to a disk group. The command dialog is similar to that described for the `vxdiskadm` command.

```
# vxdiskadm c1t1d0
```

See [“Adding a disk to VxVM”](#) on page 115.

## Removing a disk from a disk group

Before you can remove the last disk from a disk group, you must disable the disk group.

See [“Disabling a disk group”](#) on page 269.

As an alternative to disabling the disk group, you can destroy it.

See [“Destroying a disk group”](#) on page 269.

If a disk contains no subdisks, you can remove it from its disk group with the following command:

```
# vxdg [-g diskgroup] rmdisk diskname
```

For example, to remove `mydg02` from the disk group `mydg`, enter the following:

```
# vxdg -g mydg rmdisk mydg02
```

If the disk has subdisks on it when you try to remove it, the following error message is displayed:

```
VxVM vxdg ERROR V-5-1-552 Disk diskname is used by one or more  
subdisks  
Use -k to remove device assignment.
```

Using the `-k` option lets you remove the disk even if it has subdisks.

See the `vxdg(1M)` manual page.

---

**Warning:** Use of the `-k` option to `vxchg` can result in data loss.

---

After you remove the disk from its disk group, you can (optionally) remove it from VxVM control completely. Enter the following:

```
# vxdiskunsetup devicename
```

For example, to remove the disk `c1t0d0s2` from VxVM control, enter the following:

```
# vxdiskunsetup c1t0d0s2
```

You can remove a disk on which some subdisks of volumes are defined. For example, you can consolidate all the volumes onto one disk. If you use `vxdiskadm` to remove a disk, you can choose to move volumes off that disk. To do this, run `vxdiskadm` and select `Remove a disk` from the main menu.

If the disk is used by some volumes, this message is displayed:

```
VxVM ERROR V-5-2-369 The following volumes currently use part of
disk mydg02:
```

```
home usrvol
```

```
Volumes must be moved from mydg02 before it can be removed.
```

```
Move volumes to other disks? [y,n,q,?] (default: n)
```

If you choose `y`, all volumes are moved off the disk, if possible. Some volumes may not be movable. The most common reasons why a volume may not be movable are as follows:

- There is not enough space on the remaining disks.
- Plexes or striped subdisks cannot be allocated on different disks from existing plexes or striped subdisks in the volume.

If `vxdiskadm` cannot move some volumes, you may need to remove some plexes from some disks to free more space before proceeding with the disk removal operation.

## Moving disks between disk groups

To move a disk between disk groups, remove the disk from one disk group and add it to the other. For example, to move the physical disk `c0t3d0` (attached with the disk name `salesdg04`) from disk group `salesdg` and add it to disk group `mktgdg`, use the following commands:

```
# vxdg -g salesdg rmdisk salesdg04
# vxdg -g mktgdg adddisk mktgdg02=c0t3d0
```

---

**Warning:** This procedure does not save the configurations nor data on the disks.

---

You can also move a disk by using the `vxdiskadm` command. Select `Remove a disk` from the main menu, and then select `Add or initialize a disk`.

The preferred method of moving disks between disk groups preserves VxVM objects, such as volumes, that are configured on the disks.

See “[Moving objects between disk groups](#)” on page 263.

## Deporting a disk group

Deporting a disk group disables access to a disk group that is enabled (imported) by the system. Deport a disk group if you intend to move the disks in a disk group to another system.

### To deport a disk group

- 1 Stop all activity by applications to volumes that are configured in the disk group that is to be deported. Unmount file systems and shut down databases that are configured on the volumes.

If the disk group contains volumes that are in use (for example, by mounted file systems or databases), deportation fails.

- 2 To stop the volumes in the disk group, use the following command

```
# vxvol -g diskgroup stopall
```

- 3 From the `vxdiskadm` main menu, select `Remove access to (deport) a disk group`.

- 4 At prompt, enter the name of the disk group to be deported. In the following example it is `newdg`:

```
Enter name of disk group [<group>,list,q,?] (default: list)
newdg
```

- 5 At the following prompt, enter `y` if you intend to remove the disks in this disk group:

```
Disable (offline) the indicated disks? [y,n,q,?] (default: n) y
```

- 6 At the following prompt, press **Return** to continue with the operation:

```
Continue with operation? [y,n,q,?] (default: y)
```

After the disk group is deported, the `vxdiskadm` utility displays the following message:

```
VxVM INFO V-5-2-269 Removal of disk group newdg was  
successful.
```

- 7 At the following prompt, indicate whether you want to disable another disk group (y) or return to the `vxdiskadm` main menu (n):

```
Disable another disk group? [y,n,q,?] (default: n)
```

You can use the following `vx dg` command to deport a disk group:

```
# vx dg deport diskgroup
```

## Importing a disk group

Importing a disk group enables access by the system to a disk group. To move a disk group from one system to another, first disable (deport) the disk group on the original system, and then move the disk between systems and enable (import) the disk group.

### To import a disk group

- 1 To ensure that the disks in the deported disk group are online, use the following command:

```
# vx disk -s list
```

- 2 From the `vx diskadm` main menu, select Enable access to (import) a disk group.

- 3 At the following prompt, enter the name of the disk group to import (in this example, `newdg`):

```
Select disk group to import [<group>,list,q,?] (default: list)
    newdg
```

When the import finishes, the `vxdiskadm` utility displays the following success message:

```
VxVM INFO V-5-2-374 The import of newdg was successful.
```

- 4 At the following prompt, indicate whether you want to import another disk group (`y`) or return to the `vxdiskadm` main menu (`n`):

```
Select another disk group? [y,n,q,?] (default: n)
```

You can also use the following `vxdbg` command to import a disk group:

```
# vxdbg import diskgroup
```

## Handling of minor number conflicts

The volume device minor numbers in a disk group to be imported may conflict with existing volume devices. In releases of VxVM prior to 5.1, the conflicts resulted in failures; either the disk group imported failed, or the slave node failed to join for a shared disk group. When this happened, you had to run the `vxdbg reminor` command manually to resolve the minor conflicts.

From release 5.1 onward, VxVM can automatically resolve minor number conflicts. When there exists a minor conflict when a disk group is imported, the disk group is automatically assigned a new base minor, and the volumes in the disk group are reminored based on the new base minor. You do not need to run the `vxdbg reminor` command to resolve the minor conflicts.

To avoid the conflicts between shared and private disk groups, the minor numbers have been divided into shared and private pools. Minor numbers of shared disk groups are allocated only from shared pools, and minor numbers of private disk groups are allocated only from private pools. If you import a private disk group as a shared disk group or vice versa, the device minor numbers are re-allocated from the correct pool. The disk group is dynamically reminored.

By default, private minor numbers range from 0-32999, and shared minor numbers start from 33000. You can change the division if required. For example, you can set the range for shared minor numbers to start from a lower number, to provide

more minor numbers for shared disk groups and fewer minor numbers for private disk groups.

Normally the minor numbers in private and shared pools are sufficient, so there is no need to make changes to the division.

---

**Note:** To make the new division take effect, you must run `vxctl enable` or `vxconfigd restart` after the tunable is changed in the default file. The division on all the cluster nodes must be exactly the same, to prevent node failures for node join, volume creation, or disk group import operations.

---

### To change the division between shared and private minor numbers

- 1 Add the tunable `sharedminorstart` to the default file `/etc/default/vxsf`. For example, to change the shared minor numbers so that the range starts from 20000, set the following line in the `/etc/default/vxsf` file.

```
sharedminorstart=20000
```

You cannot set the shared minor numbers to start at less than 1000. If `sharedminorstart` is set to values between 0 to 999, the division of private minor numbers and shared disk group minor numbers is set to 1000. The value of 0 disables dynamic renumbering.

- 2 Run the following command:

```
# vxctl enable
```

In certain scenarios, you may need to disable the division of between shared minor numbers and private minor numbers. For example, to prevent the device minor numbers from being changed when you upgrade to VxVM 5.1. In this case, disable the dynamic renumbering before you install the new VxVM package.

### To disable the division between shared and private minor numbers

- 1 Set the tunable `sharedminorstart` to the default file `/etc/default/vxsf` to 0 (zero). Set the following line in the `/etc/default/vxsf` file.

```
sharedminorstart=0
```

- 2 Run the following command:

```
# vxctl enable
```



# Moving disk groups between systems

An important feature of disk groups is that they can be moved between systems. If all disks in a disk group are moved from one system to another, then the disk group can be used by the second system. You do not have to re-specify the configuration.

## To move a disk group between systems

- 1 Confirm that all disks in the diskgroup are visible on the target system. This may require masking and zoning changes.
- 2 On the source system, stop all volumes in the disk group, then deport (disable local access to) the disk group with the following command:

```
# vxdg deport diskgroup
```

- 3 Move all the disks to the target system and perform the steps necessary (system-dependent) for the target system and VxVM to recognize the new disks.

This can require a reboot, in which case the `vxconfigd` daemon is restarted and recognizes the new disks. If you do not reboot, use the command `vxctl enable` to restart the `vxconfigd` program so VxVM also recognizes the disks.

- 4 Import (enable local access to) the disk group on the target system with this command:

```
# vxdg import diskgroup
```

---

**Warning:** All disks in the disk group must be moved to the other system. If they are not moved, the import fails.

---

- 5 After the disk group is imported, start all volumes in the disk group with this command:

```
# vxrecover -g diskgroup -sb
```

You can also move disks from a system that has crashed. In this case, you cannot deport the disk group from the source system. When a disk group is created or imported on a system, that system writes a lock on all disks in the disk group.

---

**Warning:** The purpose of the lock is to ensure that SAN-accessed disks are not used by both systems at the same time. If two systems try to access the same disks at the same time, this must be managed using software such as the clustering functionality of VxVM. Otherwise, data and configuration information stored on the disk may be corrupted, and may become unusable.

---

## Handling errors when importing disks

When you move disks from a system that has crashed or that failed to detect the group before the disk was moved, the locks stored on the disks remain and must be cleared. The system returns the following error message:

```
VxVM vxdg ERROR V-5-1-587 disk group groupname: import failed:  
Disk is in use by another host
```

The next message indicates that the disk group does not contain any valid disks (not that it does not contain any disks):

```
VxVM vxdg ERROR V-5-1-587 Disk group groupname: import failed:  
No valid disk found containing disk group
```

The disks may be considered invalid due to a mismatch between the host ID in their configuration copies and that stored in the `/etc/vx/volboot` file.

To clear locks on a specific set of devices, use the following command:

```
# vxdisk clearimport devicename ...
```

To clear the locks during import, use the following command:

```
# vxdg -C import diskgroup
```

---

**Warning:** Be careful when using the `vxdisk clearimport` or `vxdg -C import` command on systems that see the same disks via a SAN. Clearing the locks allows those disks to be accessed at the same time from multiple hosts and can result in corrupted data.

---

A disk group can be imported successfully if all the disks are accessible that were visible when the disk group was last imported successfully. However, sometimes you may need to specify the `-f` option to forcibly import a disk group if some disks are not available. If the `import` operation fails, an error message is displayed.

The following error message indicates a fatal error that requires hardware repair or the creation of a new disk group, and recovery of the disk group configuration and data:

```
VxVM vxdg ERROR V-5-1-587 Disk group groupname: import failed:  
Disk group has no valid configuration copies
```

The following error message indicates a recoverable error.

```
VxVM vxdg ERROR V-5-1-587 Disk group groupname: import failed:  
Disk for disk group not found
```

If some of the disks in the disk group have failed, you can force the disk group to be imported by specifying the `-f` option to the `vxdg import` command:

```
# vxdg -f import diskgroup
```

---

**Warning:** Be careful when using the `-f` option. It can cause the same disk group to be imported twice from different sets of disks. This can cause the disk group configuration to become inconsistent.

---

See [“Handling conflicting configuration copies”](#) on page 250.

As using the `-f` option to force the import of an incomplete disk group counts as a successful import, an incomplete disk group may be imported subsequently without this option being specified. This may not be what you expect.

These operations can also be performed using the `vxdiskadm` utility. To deport a disk group using `vxdiskadm`, select `Remove access to (deport)` a disk group

from the main menu. To import a disk group, select `Enable access to (import)` a disk group. The `vxdiskadm import` operation checks for host import locks and prompts to see if you want to clear any that are found. It also starts volumes in the disk group.

## Reserving minor numbers for disk groups

A device minor number uniquely identifies some characteristic of a device to the device driver that controls that device. It is often used to identify some characteristic mode of an individual device, or to identify separate devices that are all under the control of a single controller. VxVM assigns unique device minor numbers to each object (volume, plex, subdisk, disk, or disk group) that it controls.

When you move a disk group between systems, it is possible for the minor numbers that it used on its previous system to coincide with those of objects known to VxVM on the new system. To get around this potential problem, you can allocate separate ranges of minor numbers for each disk group. VxVM uses the specified range of minor numbers when it creates volume objects from the disks in the disk group. This guarantees that each volume has the same minor number across reboots or reconfigurations. Disk groups may then be moved between machines without causing device number collisions.

VxVM chooses minor device numbers for objects created from this disk group starting at the base minor number `base_minor`. Minor numbers can range from this value up to 131,071. Try to leave a reasonable number of unallocated minor numbers near the top of this range to allow for temporary device number remapping in the event that a device minor number collision may still occur.

VxVM reserves the range of minor numbers from 0 to 999 for use with volumes in the boot disk group. For example, the `rootvol` volume is always assigned minor number 0.

If you do not specify the base of the minor number range for a disk group, VxVM chooses one at random. The number chosen is at least 1000, is a multiple of 1000, and yields a usable range of 1000 device numbers. The chosen number also does not overlap within a range of 1000 of any currently imported disk groups, and it does not overlap any currently allocated volume device numbers.

---

**Note:** The default policy ensures that a small number of disk groups can be merged successfully between a set of machines. However, where disk groups are merged automatically using failover mechanisms, select ranges that avoid overlap.

---

To view the base minor number for an existing disk group, use the `vxprint` command as shown in the following examples for the disk group, `mydg`:

```
# vxprint -l mydg | grep minors  
minors: >=45000
```

```
# vxprint -g mydg -m | egrep base_minor  
base_minor=45000
```

To set a base volume device minor number for a disk group that is being created, use the following command:

```
# vxdg init diskgroup minor=base_minor disk_access_name ...
```

For example, the following command creates the disk group, `newdg`, that includes the specified disks, and has a base minor number of 30000:

```
# vxdg init newdg minor=30000 c1d0t0s2 c1t1d0s2
```

If a disk group already exists, you can use the `vxdg reminor` command to change its base minor number:

```
# vxdg -g diskgroup reminor new_base_minor
```

For example, the following command changes the base minor number to 30000 for the disk group, `mydg`:

```
# vxdg -g mydg reminor 30000
```

If a volume is open, its old device number remains in effect until the system is rebooted or until the disk group is deported and re-imported. If you close the open volume, you can run `vxdg reminor` again to allow the renumbering to take effect without rebooting or re-importing.

An example of where it is necessary to change the base minor number is for a cluster-shareable disk group. The volumes in a shared disk group must have the same minor number on all the nodes. If there is a conflict between the minor numbers when a node attempts to join the cluster, the join fails. You can use the `reminor` operation on the nodes that are in the cluster to resolve the conflict. In a cluster where more than one node is joined, use a base minor number which does not conflict on any node.

See the `vxdg(1M)` manual page.

---

**Note:** The base minor value for `vxdg init` and `vxdg reminor` must be in the correct range. For private disk groups, the value can only be in the range of private pool (0-32999 by default). For shared disk group, the value can only be in the range of shared pool (greater than 33000 by default).

---

See “[Handling of minor number conflicts](#)” on page 231.

## Compatibility of disk groups between platforms

For disk groups that support the Cross-platform Data Sharing (CDS) feature, the upper limit on the minor number range is restricted on AIX, HP-UX, Linux (with a 2.6 or later kernel) and Solaris to 65,535 to ensure portability between these operating systems.

On a Linux platform with a pre-2.6 kernel, the number of minor numbers per major number is limited to 256 with a base of 0. This has the effect of limiting the number of volumes and disks that can be supported system-wide to a smaller value than is allowed on other operating system platforms. The number of disks that are supported by a pre-2.6 Linux kernel is typically limited to a few hundred. With the extended major numbering scheme that was implemented in VxVM 4.0 on Linux, a maximum of 4079 volumes could be configured, provided that a contiguous block of 15 extended major numbers was available.

VxVM 4.1 and later releases run on a 2.6 version Linux kernel, which increases the number of minor devices that are configurable from 256 to 65,536 per major device number. This allows a large number of volumes and disk devices to be configured on a system. The theoretical limit on the number of DMP and volume devices that can be configured on such a system are 65,536 and 1,048,576 respectively. However, in practice, the number of VxVM devices that can be configured in a single disk group is limited by the size of the private region.

When a CDS-compatible disk group is imported on a Linux system with a pre-2.6 kernel, VxVM attempts to reassign the minor numbers of the volumes, and fails if this is not possible.

To help ensure that a CDS-compatible disk group is portable between operating systems, including Linux with a pre-2.6 kernel, use the following command to set the `maxdev` attribute on the disk group:

```
# vxvg -g diskgroup set maxdev=4079
```

---

**Note:** Such a disk group may still not be importable by VxVM 4.0 on Linux with a pre-2.6 kernel if it would increase the number of minor numbers on the system that are assigned to volumes to more than 4079, or if the number of available extended major numbers is smaller than 15.

---

You can use the following command to discover the maximum number of volumes that are supported by VxVM on a Linux host:

```
# cat /proc/sys/vxvm/vxio/vol_max_volumes
4079
```

See the `vx dg(1M)` manual page.

## Handling cloned disks with duplicated identifiers

A disk may be copied by creating a hardware snapshot (such as an EMC BCV™ or Hitachi ShadowCopy™) or clone, by using `dd` or a similar command to replicate the disk, or by building a new LUN from the space that was previously used by a deleted LUN. To avoid the duplicate disk ID condition, the default action of VxVM is to prevent such duplicated disks from being imported.

Advanced disk arrays provide hardware tools that you can use to create clones of existing disks outside the control of VxVM. For example, these disks may have been created as hardware snapshots or mirrors of existing disks in a disk group. As a result, the VxVM private region is also duplicated on the cloned disk. When the disk group containing the original disk is subsequently imported, VxVM detects multiple disks that have the same disk identifier that is defined in the private region. In releases prior to 5.0, if VxVM could not determine which disk was the original, it would not import such disks into the disk group. The duplicated disks would have to be re-initialized before they could be imported.

From release 5.0, a unique disk identifier (UDID) is added to the disk's private region when the disk is initialized or when the disk is imported into a disk group (if this identifier does not already exist). Whenever a disk is brought online, the current UDID value that is known to the Device Discovery Layer (DDL) is compared with the UDID that is set in the disk's private region. If the UDID values do not match, the `udid_mismatch` flag is set on the disk. This flag can be viewed with the `vx disk list` command. This allows a LUN snapshot to be imported on the same host as the original LUN. It also allows multiple snapshots of the same LUN to be simultaneously imported on a single server, which can be useful for off-host backup and processing.

A new set of `vx disk` and `vx dg` operations are provided to handle such disks; either by writing the DDL value of the UDID to a disk's private region, or by tagging a disk and specifying that it is a cloned disk to the `vx dg import` operation.

The following is sample output from the `vx disk list` command showing that disks `c2t66d0s2`, `c2t67d0s2` and `c2t68d0s2` are marked with the `udid_mismatch` flag:

```
# vx disk list
```

DEVICE	TYPE	DISK	GROUP	STATUS
--------	------	------	-------	--------

```

c0t0d0s2      auto:cdsdisk -      -      online
c0t1d0s2      auto:cdsdisk -      -      online
.
.
.
c2t64d0s2     auto:cdsdisk -      -      online
c2t65d0s2     auto:cdsdisk -      -      online
c2t66d0s2     auto:cdsdisk -      -      online udid_mismatch
c2t67d0s2     auto:cdsdisk -      -      online udid_mismatch
c2t68d0s2     auto:cdsdisk -      -      online udid_mismatch

```

## Writing a new UDID to a disk

You can use the following command to update the unique disk identifier (UDID) for one or more disks. This is useful when building a new LUN from space previously used by a deleted LUN, for example.

```
# vxdisk [-f] [-g diskgroup] updateudid disk ...
```

This command uses the current value of the UDID that is stored in the Device Discovery Layer (DDL) database to correct the value in the private region. The `-f` option must be specified if VxVM has not set the `udid_mismatch` flag for a disk.

For example, the following command updates the UDIDs for the disks `c2t66d0s2` and `c2t67d0s2`:

```
# vxdisk updateudid c2t66d0s2 c2t67d0s2
```

## Importing a disk group containing cloned disks

By default, disks on which the `udid_mismatch` flag or the `clone_disk` flag has been set are not imported by the `vx dg import` command unless all disks in the disk group have at least one of these flags set, and no two of the disks have the same UDID. You can then import the cloned disks by specifying the `-o useclonedev=on` option to the `vx dg import` command, as shown in this example:

```
# vx dg -o useclonedev=on [-o updateid] import mydg
```

This form of the command allows only cloned disks to be imported. All non-cloned disks remain unimported.

If the `clone_disk` flag is set on a disk, this indicates the disk was previously imported into a disk group with the `udid_mismatch` flag set.

The `-o updateid` option can be specified to write new identification attributes to the disks, and to set the `clone_disk` flag on the disks. (The `vx disk set clone=on`



command can also be used to set the flag.) However, the import fails if multiple copies of one or more cloned disks exist. In this case, you can use the following command to tag all the disks in the disk group that are to be imported:

```
# vxdisk [-g diskgroup ] settag tagname disk ...
```

where *tagname* is a string of up to 128 characters, not including spaces or tabs.

For example, the following command sets the tag, `,` on several disks that are to be imported together:

```
# vxdisk settag my_tagged_disks c2t66d0s2 c2t67d0s2
```

Alternatively, you can update the UDIDs of the cloned disks.

See [“Writing a new UDID to a disk”](#) on page 240.

To check which disks are tagged, use the `vxdisk listtag` command:

```
# vxdisk listtag
```

DANAME	DMNAME	NAME	VALUE
c0t0d0s2	mydg01	-	-
c0t1d0s2	mydg02	-	-
.	.	.	.
c2t64d0s2	mydg05	my_tagged_disks	-
c2t65d0s2	mydg06	my_tagged_disks	-
c2t66d0s2	mydg07	my_tagged_disks	-
c2t67d0s2	mydg08	my_tagged_disks	-
c2t68d0s2	mydg09	-	-

The configuration database in a VM disk’s private region contains persistent configuration data (or metadata) about the objects in a disk group. This database is consulted by VxVM when the disk group is imported. At least one of the cloned disks that are being imported must contain a copy of the current configuration database in its private region.

You can use the following command to ensure that a copy of the metadata is placed on a disk, regardless of the placement policy for the disk group:

```
# vxdisk [-g diskgroup] set disk keepmeta=always
```

Alternatively, use the following command to place a copy of the configuration database and kernel log on all disks in a disk group that share a given tag:

```
# vxdg [-g diskgroup] set tagmeta=on tag=tagname nconfig=all \  
nlog=all
```

To check which disks in a disk group contain copies of this configuration information, use the `vxdg listmeta` command:

```
# vxdg [-q] listmeta diskgroup
```

The `-q` option can be specified to suppress detailed configuration information from being displayed.

The tagged disks in the disk group may be imported by specifying the tag to the `vxdg import` command in addition to the `-o useclonedev=on` option:

```
# vxdg -o useclonedev=on -o tag=my_tagged_disks import mydg
```

If you have already imported the non-cloned disks in a disk group, you can use the `-n` and `-t` option to specify a temporary name for the disk group containing the cloned disks:

```
# vxdg -t -n clonedg -o useclonedev=on -o tag=my_tagged_disks \  
import mydg
```

See [“Renaming a disk group”](#) on page 248.

To remove a tag from a disk, use the `vxdisk rmtag` command, as shown in the following example:

```
# vxdisk rmtag tag=my_tagged_disks c2t67d0s2
```

See the `vxdisk(1M)` and `vxdg(1M)` manual pages.

## Sample cases of operations on cloned disks

The following sections contain examples of operations that can be used with cloned disks:

See [“Enabling configuration database copies on tagged disks”](#) on page 242.

See [“Importing cloned disks without tags”](#) on page 244.

See [“Importing cloned disks with tags”](#) on page 246.

### Enabling configuration database copies on tagged disks

In this example, the following commands have been used to tag some of the disks in an Hitachi TagmaStore array:

```
# vxdisk settag TagmaStore-USP0_28 t1=v1
# vxdisk settag TagmaStore-USP0_28 t2=v2
# vxdisk settag TagmaStore-USP0_24 t2=v2
# vxdisk settag TagmaStore-USP0_25 t1=v1
```

These tags can be viewed by using the `vxdisk listtag` command:

```
# vxdisk listtag

DEVICE                NAME    VALUE
TagmaStore-USP0_24   t2      v2
TagmaStore-USP0_25   t1      v1
TagmaStore-USP0_28   t1      v1
TagmaStore-USP0_28   t2      v2
```

The following command ensures that configuration database copies and kernel log copies are maintained for all disks in the disk group `mydg` that are tagged as `t1`:

```
# vxdg -g mydg set tagmeta=on tag=t1 nconfig=all nlog=all
```

The disks for which such metadata is maintained can be seen by using this command:

```
# vxdisk -o alldgs list

DEVICE                TYPE          DISK    GROUP    STATUS
TagmaStore-USP0_10   auto:cdsdisk -        -        online
TagmaStore-USP0_24   auto:cdsdisk mydg02   mydg     online
TagmaStore-USP0_25   auto:cdsdisk mydg03   mydg     online tagmeta
TagmaStore-USP0_26   auto:cdsdisk -        -        online
TagmaStore-USP0_27   auto:cdsdisk -        -        online
TagmaStore-USP0_28   auto:cdsdisk mydg01   mydg     online tagmeta
```

Alternatively, the following command can be used to ensure that a copy of the metadata is kept with a disk:

```
# vxdisk set TagmaStore-USP0_25 keepmeta=always
# vxdisk -o alldgs list
```

```
DEVICE                TYPE          DISK    GROUP    STATUS
TagmaStore-USP0_10   auto:cdsdisk -        -        online
TagmaStore-USP0_22   auto:cdsdisk -        -        online
TagmaStore-USP0_23   auto:cdsdisk -        -        online
TagmaStore-USP0_24   auto:cdsdisk mydg02   mydg     online
```

```
TagmaStore-USP0_25 auto:cdsdisk mydg03 mydg online keepmeta
TagmaStore-USP0_28 auto:cdsdisk mydg01 mydg online
```

## Importing cloned disks without tags

In the first example, cloned disks (ShadowImage™ devices) from an Hitachi TagmaStore array will be imported. The primary (non-cloned) disks, `mydg01`, `mydg02` and `mydg03`, are already imported, and the cloned disks are not tagged.

```
# vxdisk -o alldgs list
```

```
DEVICE          TYPE          DISK          GROUP         STATUS
TagmaStore-USP0_3 auto:cdsdisk -          (mydg)       online udid_mismatch
TagmaStore-USP0_23 auto:cdsdisk mydg02      mydg         online
TagmaStore-USP0_25 auto:cdsdisk mydg03      mydg         online
TagmaStore-USP0_30 auto:cdsdisk -          (mydg)       online udid_mismatch
TagmaStore-USP0_31 auto:cdsdisk -          (mydg)       online udid_mismatch
TagmaStore-USP0_32 auto:cdsdisk mydg01      mydg         online
```

To import the cloned disks, they must be assigned a new disk group name, and their UDIDs must be updated:

```
# vxvg -n snapdg -o useclonedev=on -o updateid import mydg
# vxdisk -o alldgs list
```

```
DEVICE          TYPE          DISK          GROUP         STATUS
TagmaStore-USP0_3 auto:cdsdisk mydg03      snapdg       online clone_disk
TagmaStore-USP0_23 auto:cdsdisk mydg02      mydg         online
TagmaStore-USP0_25 auto:cdsdisk mydg03      mydg         online
TagmaStore-USP0_30 auto:cdsdisk mydg02      snapdg       online clone_disk
TagmaStore-USP0_31 auto:cdsdisk mydg01      snapdg       online clone_disk
TagmaStore-USP0_32 auto:cdsdisk mydg01      mydg         online
```

Note that the state of the imported cloned disks has changed from `online udid_mismatch` to `online clone_disk`.

In the next example, none of the disks (neither cloned nor non-cloned) have been imported:

```
# vxdisk -o alldgs list
```

```
DEVICE          TYPE          DISK          GROUP         STATUS
TagmaStore-USP0_3 auto:cdsdisk -          (mydg)       online udid_mismatch
TagmaStore-USP0_23 auto:cdsdisk -          (mydg)       online
TagmaStore-USP0_25 auto:cdsdisk -          (mydg)       online
```

```
TagmaStore-USP0_30 auto:cdsdisk - (mydg) online udid_mismatch
TagmaStore-USP0_31 auto:cdsdisk - (mydg) online udid_mismatch
TagmaStore-USP0_32 auto:cdsdisk - (mydg) online
```

To import only the cloned disks into the `mydg` disk group:

```
# vxdg -o useclonedev=on -o updateid import mydg
# vxdisk -o alldgs list
```

```
DEVICE          TYPE          DISK          GROUP          STATUS
TagmaStore-USP0_3 auto:cdsdisk mydg03 mydg          online clone_disk
TagmaStore-USP0_23 auto:cdsdisk - (mydg)       online
TagmaStore-USP0_25 auto:cdsdisk - (mydg)       online
TagmaStore-USP0_30 auto:cdsdisk mydg02 mydg          online clone_disk
TagmaStore-USP0_31 auto:cdsdisk mydg01 mydg          online clone_disk
TagmaStore-USP0_32 auto:cdsdisk - (mydg)       online
```

In the next example, a cloned disk (BCV device) from an EMC Symmetrix DMX array is to be imported. Before the cloned disk, `EMC0_27`, has been split off from the disk group, the `vxdisk list` command shows that it is in the `error udid_mismatch` state:

```
# vxdisk -o alldgs list
DEVICE          TYPE          DISK          GROUP          STATUS
EMC0_1          auto:cdsdisk EMC0_1 mydg          online
EMC0_27         auto          -             -             error udid_mismatch
```

The `symmir` command is used to split off the BCV device:

```
# /usr/symcli/bin/symmir -g mydg split DEV001
```

After updating VxVM's information about the disk by running the `vxdisk scandisks` command, the cloned disk is in the `online udid_mismatch` state:

```
# vxdisk -o alldgs list
DEVICE          TYPE          DISK          GROUP          STATUS
EMC0_1          auto:cdsdisk EMC0_1 mydg          online
EMC0_27         auto:cdsdisk -             -             online udid_mismatch
```

The following command imports the cloned disk into the new disk group `newdg`, and updates the disk's UDID:

```
# vxdg -n bcvdg -o useclonedev=on -o updateid import mydg
```

The state of the cloned disk is now shown as `online clone_disk`:

```
# vxdisk -o alldgs list
DEVICE          TYPE          DISK          GROUP  STATUS
EMC0_1          auto:cdsdisk EMC0_1        mydg   online
EMC0_27         auto:cdsdisk EMC0_1        bvc dg  online clone_disk
```

## Importing cloned disks with tags

In this example, cloned disks (BCV devices) from an EMC Symmetrix DMX array will be imported. The primary (non-cloned) disks, `mydg01`, `mydg02` and `mydg03`, are already imported, and the cloned disks with the tag `t1` are to be imported.

```
# vxdisk -o alldgs list

DEVICE          TYPE          DISK          GROUP  STATUS
EMC0_4          auto:cdsdisk mydg01        mydg   online
EMC0_6          auto:cdsdisk mydg02        mydg   online
EMC0_8          auto:cdsdisk -            (mydg) online udid_mismatch
EMC0_15         auto:cdsdisk -            (mydg) online udid_mismatch
EMC0_18         auto:cdsdisk mydg03        mydg   online
EMC0_24         auto:cdsdisk -            (mydg) online udid_mismatch
```

The disks are tagged as follows:

```
# vxdisk listtag

DEVICE          NAME  VALUE
EMC0_4          t2    v2
EMC0_4          t1    v1
EMC0_6          t2    v2
EMC0_8          t1    v1
EMC0_15         t2    v2
EMC0_18         t1    v1
EMC0_24         t1    v1
EMC0_24         t2    v2
```

To import the cloned disks that are tagged as `t1`, they must be assigned a new disk group name, and their UDIDs must be updated:

```
# vxdg -n bvc dg -o useclonedev=on -o tag=t1 -o updateid import mydg
# vxdisk -o alldgs list

DEVICE          TYPE          DISK          GROUP  STATUS
EMC0_4          auto:cdsdisk mydg01        mydg   online
EMC0_6          auto:cdsdisk mydg02        mydg   online
EMC0_8          auto:cdsdisk mydg03        bvc dg  online clone_disk
```

```
EMC0_15          auto:cdsdisk -      (mydg)  online udid_mismatch
EMC0_18          auto:cdsdisk mydg03  mydg    online
EMC0_24          auto:cdsdisk mydg01  bcvdg   online clone_disk
```

As the cloned disk `EMC0_15` is not tagged as `t1`, it is not imported. Note that the state of the imported cloned disks has changed from `online udid_mismatch` to `online clone_disk`.

By default, the state of imported cloned disks is shown as `online clone_disk`. This can be removed by using the `vxdisk set` command as shown here:

```
# vxdisk set EMC0_8 clone=off
# vxdisk -o alldgs list
```

```
DEVICE          TYPE          DISK          GROUP  STATUS
EMC0_4          auto:cdsdisk mydg01    mydg   online
EMC0_6          auto:cdsdisk mydg02    mydg   online
EMC0_8          auto:cdsdisk mydg03    bcvdg  online
EMC0_15         auto:cdsdisk -          (mydg) online udid_mismatch
EMC0_18         auto:cdsdisk mydg03    mydg   online
EMC0_24         auto:cdsdisk mydg01    bcvdg  online clone_disk
```

In the next example, none of the disks (neither cloned nor non-cloned) have been imported:

```
# vxdisk -o alldgs list
```

```
DEVICE          TYPE          DISK          GROUP  STATUS
EMC0_4          auto:cdsdisk -          (mydg) online
EMC0_6          auto:cdsdisk -          (mydg) online
EMC0_8          auto:cdsdisk -          (mydg) online udid_mismatch
EMC0_15         auto:cdsdisk -          (mydg) online udid_mismatch
EMC0_18         auto:cdsdisk -          (mydg) online
EMC0_24         auto:cdsdisk -          (mydg) online udid_mismatch
```

To import only the cloned disks that have been tagged as `t1` into the `mydg` disk group:

```
# vxdg -o useclonedev=on -o tag=t1 -o updateid import mydg
# vxdisk -o alldgs list
```

```
DEVICE          TYPE          DISK          GROUP  STATUS
EMC0_4          auto:cdsdisk -          (mydg) online
EMC0_6          auto:cdsdisk -          (mydg) online
EMC0_8          auto:cdsdisk mydg03    mydg   online clone_disk
```

```
EMC0_15          auto:cdsdisk -      (mydg) online udid_mismatch
EMC0_18          auto:cdsdisk -      (mydg) online
EMC0_24          auto:cdsdisk mydg01  mydg  online clone_disk
```

As in the previous example, the cloned disk `EMC0_15` is not tagged as `t1`, and so it is not imported.

## Considerations when using EMC CLARiiON SNAPSHOT LUNs

If you need to import the Snapshot LUN of a primary LUN to the same host as the original LUN, be aware of the following limitation.

If you are using Enclosure-based naming (EBN) with the Array Volume id (AVID) enabled, turn off name persistence during device discovery before importing the snapshot LUN to the original host.

To turn off name persistence, use the following command:

```
# vxddladm set namingscheme=ebn persistence=no use_avid=yes
```

After DDL recognizes the LUN, turn on name persistence using the following command:

```
# vxddladm set namingscheme=ebn persistence=yes use_avid=yes
```

## Renaming a disk group

Only one disk group of a given name can exist per system. It is not possible to import or deport a disk group when the target system already has a disk group of the same name. To avoid this problem, VxVM allows you to rename a disk group during import or deport.

To rename a disk group during import, use the following command:

```
# vxdg [-t] -n newdg import diskgroup
```

If the `-t` option is included, the import is temporary and does not persist across reboots. In this case, the stored name of the disk group remains unchanged on its original host, but the disk group is known by the name specified by `newdg` to the importing host. If the `-t` option is not used, the name change is permanent.

For example, this command temporarily renames the disk group, `mydg`, as `mytempdg` on import:

```
# vxdg -t -n mytempdg import mydg
```

To rename a disk group during deport, use the following command:



```
# vxdg [-h hostname] -n newdg deport diskgroup
```

When renaming on deport, you can specify the `-h hostname` option to assign a lock to an alternate host. This ensures that the disk group is automatically imported when the alternate host reboots.

For example, this command renames the disk group, `mydg`, as `myexdg`, and deports it to the host, `jingo`:

```
# vxdg -h jingo -n myexdg deport mydg
```

You cannot use this method to rename the boot disk group because it contains volumes that are in use by mounted file systems (such as `/`). To rename the boot disk group, you must first unmirror and unencapsulate the root disk, and then re-encapsulate and remirror the root disk in a different disk group. This disk group becomes the new boot disk group.

**To temporarily move the boot disk group, `bootdg`, from one host to another (for repair work on the root volume, for example) and then move it back**

- 1 On the original host, identify the disk group ID of the `bootdg` disk group to be imported with the following command:

```
# vxdisk -g bootdg -s list
```

```
dgname: rootdg  
dgid: 774226267.1025.tweety
```

In this example, the administrator has chosen to name the boot disk group as `rootdg`. The ID of this disk group is `774226267.1025.tweety`.

This procedure assumes that all the disks in the boot disk group are accessible by both hosts.

- 2 Shut down the original host.

- 3 On the importing host, import and rename the `rootdg` disk group with this command:

```
# vxdg -tC -n newdg import diskgroup
```

The `-t` option indicates a temporary import name, and the `-c` option clears import locks. The `-n` option specifies an alternate name for the `rootdg` being imported so that it does not conflict with the existing `rootdg`. `diskgroup` is the disk group ID of the disk group being imported (for example, `774226267.1025.tweety`).

If a reboot or crash occurs at this point, the temporarily imported disk group becomes unimported and requires a reimport.

- 4 After the necessary work has been done on the imported disk group, deport it back to its original host with this command:

```
# vxdg -h hostname deport diskgroup
```

Here `hostname` is the name of the system whose `rootdg` is being returned (the system name can be confirmed with the command `uname -n`).

This command removes the imported disk group from the importing host and returns locks to its original host. The original host can then automatically import its boot disk group at the next reboot.

## Handling conflicting configuration copies

If an incomplete disk group is imported on several different systems, this can create inconsistencies in the disk group configuration copies that you may need to resolve manually. This section and following sections describe how such a condition can occur, and how to correct it. (When the condition occurs in a cluster that has been split, it is usually referred to as a serial split brain condition).

### Example of a serial split brain condition in a cluster

This section presents an example of how a serial split brain condition might occur for a shared disk group in a cluster. Conflicts between configuration copies can also occur for private disk groups in clustered and non-clustered configurations where the disk groups have been partially imported on different systems.

A campus cluster (also known as a stretch cluster or remote mirror configuration) typically consists of a 2-node cluster where each component (server, switch and storage) of the cluster exists in a separate building.

Figure 5-1 shows a 2-node cluster with node 0, a fibre channel switch and disk enclosure `enc0` in building A, and node 1, another switch and enclosure `enc1` in building B.

**Figure 5-1** Typical arrangement of a 2-node campus cluster

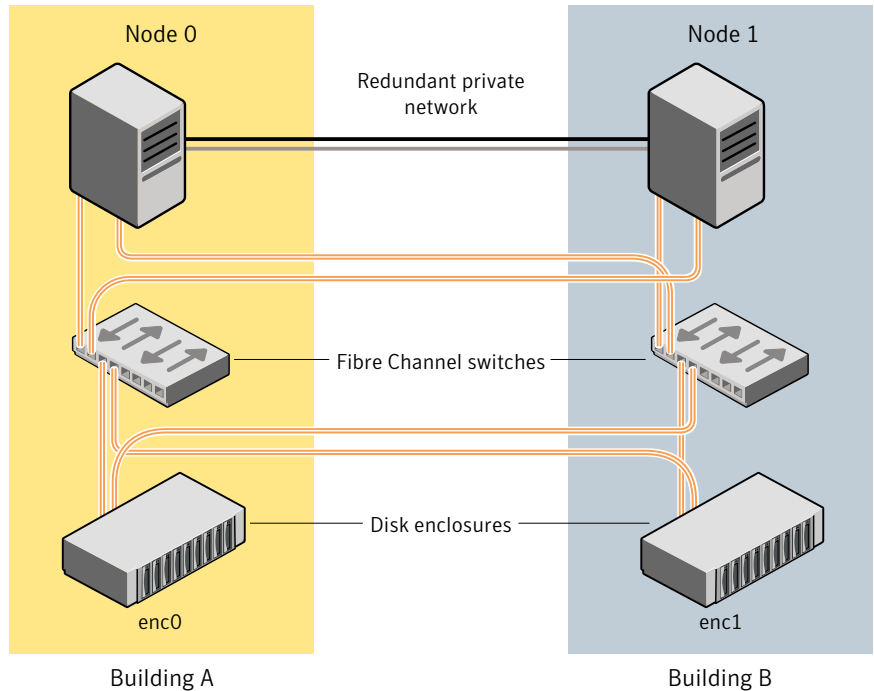

The fibre channel connectivity is multiply redundant to implement redundant-loop access between each node and each enclosure. As usual, the two nodes are also linked by a redundant private network.

A serial split brain condition typically arises in a cluster when a private (non-shared) disk group is imported on Node 0 with Node 1 configured as the failover node.

If the network connections between the nodes are severed, both nodes think that the other node has died. (This is the usual cause of the split brain condition in clusters). If a disk group is spread across both enclosure `enc0` and `enc1`, each portion loses connectivity to the other portion of the disk group. Node 0 continues to update to the disks in the portion of the disk group that it can access. Node 1, operating as the failover node, imports the other portion of the disk group (with the `-f` option set), and starts updating the disks that it can see.

When the network links are restored, attempting to reattach the missing disks to the disk group on Node 0, or to re-import the entire disk group on either node, fails. This serial split brain condition arises because VxVM increments the serial ID in the disk media record of each imported disk in all the disk group configuration databases on those disks, and also in the private region of each imported disk. The value that is stored in the configuration database represents the serial ID that the disk group expects a disk to have. The serial ID that is stored in a disk's private region is considered to be its actual value.

If some disks went missing from the disk group (due to physical disconnection or power failure) and those disks were imported by another host, the serial IDs for the disks in their copies of the configuration database, and also in each disk's private region, are updated separately on that host. When the disks are subsequently re-imported into the original shared disk group, the actual serial IDs on the disks do not agree with the expected values from the configuration copies on other disks in the disk group.

Depending on what happened to the different portions of the split disk group, there are two possibilities for resolving inconsistencies between the configuration databases:

- If the other disks in the disk group were not imported on another host, VxVM resolves the conflicting values of the serial IDs by using the version of the configuration database from the disk with the greatest value for the updated ID (shown as `update_tid` in the output from the `vxdg list diskgroup` command).

Figure 5-2 shows an example of a serial split brain condition that can be resolved automatically by VxVM.

**Figure 5-2** Example of a serial split brain condition that can be resolved automatically

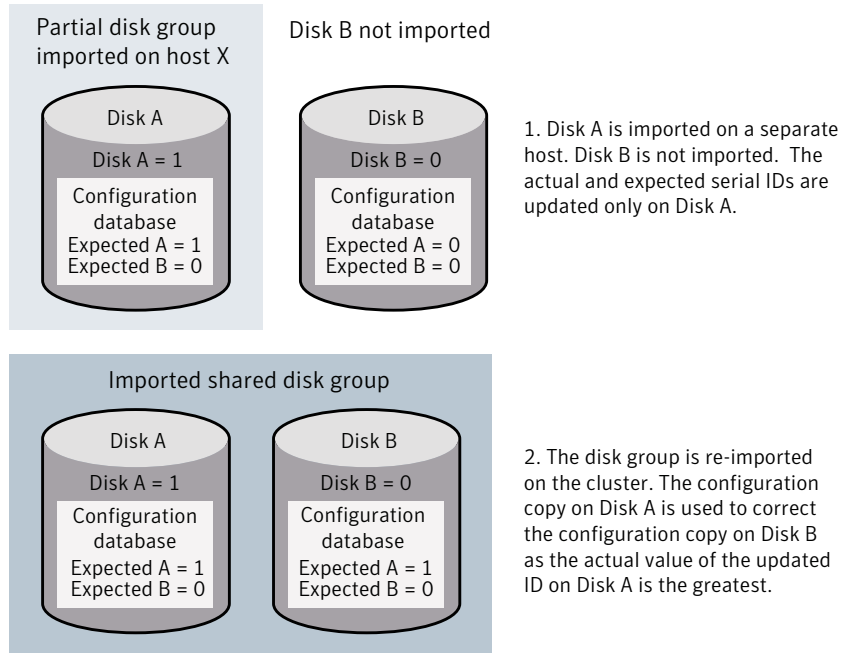

- If the other disks were also imported on another host, no disk can be considered to have a definitive copy of the configuration database.

Figure 5-3 shows an example of a true serial split brain condition that cannot be resolved automatically by VxVM.

**Figure 5-3** Example of a true serial split brain condition that cannot be resolved automatically

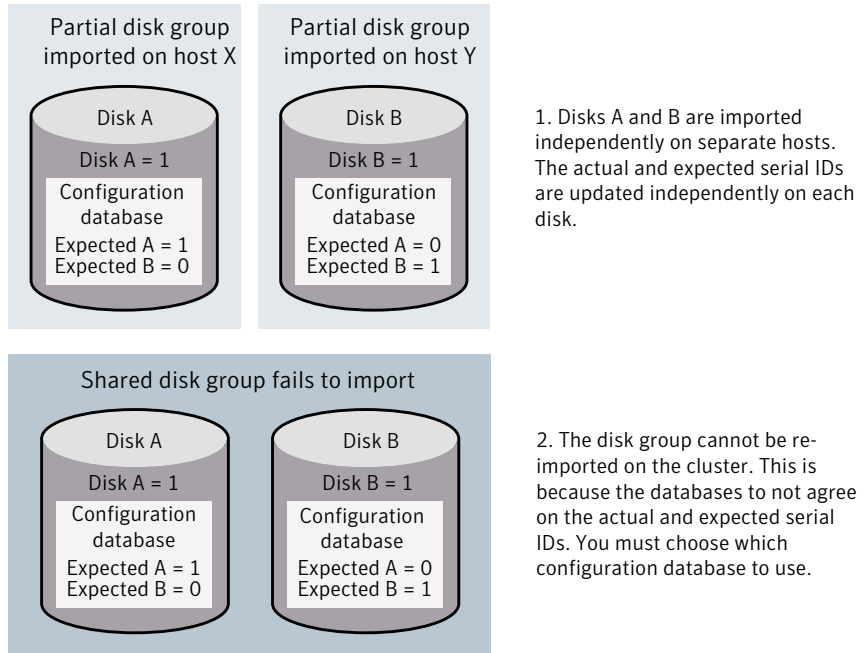

In this case, the disk group import fails, and the `vxvg` utility outputs error messages similar to the following before exiting:

```
VxVM vxconfigd NOTICE V-5-0-33 Split Brain. da id is 0.1, while dm id is 0.0 for DM mydg01
VxVM vxvg ERROR V-5-1-587 Disk group newdg: import failed: Serial Split Brain detected. Run vxsplitlines
```

The import does not succeed even if you specify the `-f` flag to `vxvg`.

Although it is usually possible to resolve this conflict by choosing the version of the configuration database with the highest valued configuration ID (shown as the value of `seqno` in the output from the `vxvg list diskgroup | grep config` command), this may not be the correct thing to do in all circumstances.

See [“Correcting conflicting configuration information”](#) on page 254.

## Correcting conflicting configuration information

To resolve conflicting configuration information, you must decide which disk contains the correct version of the disk group configuration database. To assist

you in doing this, you can run the `vxsplitlines` command to show the actual serial ID on each disk in the disk group and the serial ID that was expected from the configuration database. For each disk, the command also shows the `vxldg` command that you must run to select the configuration database copy on that disk as being the definitive copy to use for importing the disk group.

---

**Note:** The disk group must have a version number of at least 110.

---

The following is sample output from running `vxsplitlines` on the disk group `newdg`:

```
# vxsplitlines -g newdg
```

```
The following splits were found in disk group newdg
They are listed in da(dm) name pairs.
```

```
Pool 0.
```

```
    c2t5d0s2 ( c2t5d0s2 ), c2t6d0s2 ( c2t6d0s2 ),
The configuration from any of the disks in this split should appear to be the same.
To see the configuration from any of the disks in this split, run:
    /etc/vx/diag.d/vxprivutil dumpconfig /dev/vx/dmp/c2t5d0s2
To import the dg with the configuration from this split, run:
    /usr/sbin/vxdg -o selectcp=1045852127.32.olancha import newdg
To get more information about this particular configuration, run:
    /usr/sbin/vxsplitlines -g newdg -c c2t5d0s2
```

```
Split 1.
```

```
c2t7d0s2 ( c2t7d0s2 ), c2t8d0s2 ( c2t8d0s2 ),
The configuration from any of the disks in this split should appear to be the same.
To see the configuration from any of the disks in this split, run:
    /etc/vx/diag.d/vxprivutil dumpconfig /dev/vx/dmp/c2t7d0s2
To import the dg with the configuration from this split, run:
    /usr/sbin/vxdg -o selectcp=1045852127.33.olancha import newdg
To get more information about this particular configuration, run:
    /usr/sbin/vxsplitlines -g newdg -c c2t7d0s2
```

In this example, the disk group has four disks, and is split so that two disks appear to be on each side of the split.

You can specify the `-c` option to `vxsplitlines` to print detailed information about each of the disk IDs from the configuration copy on a disk specified by its disk access name:

```
# vxsplitlines -g newdg -c c2t6d0s2
DANAME (DMNAME) || Actual SSB      || Expected SSB
c2t5d0s2( c2t5d0s2 ) || 0.1      || 0.0 ssb ids don't match
c2t6d0s2( c2t6d0s2 ) || 0.1      || 0.1 ssb ids match
c2t7d0s2( c2t7d0s2 ) || 0.1      || 0.1 ssb ids match
c2t8d0s2( c2t8d0s2 ) || 0.1      || 0.0 ssb ids don't match
```

Please note that even though some disks ssb ids might match that does not necessarily mean that those disks' config copies have all the changes. From some other configuration copies, those disks' ssb ids might not match. To see the configuration from this disk, run  
`/etc/vx/diag.d/vxprivutil dumpconfig /dev/vx/dmp/c2t6d0s2`

Based on your knowledge of how the serial split brain condition came about, you must choose one disk's configuration to be used to import the disk group. For example, the following command imports the disk group using the configuration copy that is on side 0 of the split:

```
# /usr/sbin/vxdg -o selectcp=1045852127.32.olancha import newdg
```

When you have selected a preferred configuration copy, and the disk group has been imported, VxVM resets the serial IDs to 0 for the imported disks. The actual and expected serial IDs for any disks in the disk group that are not imported at this time remain unaltered.

## Reorganizing the contents of disk groups

There are several circumstances under which you might want to reorganize the contents of your existing disk groups:

- To group volumes or disks differently as the needs of your organization change. For example, you might want to split disk groups to match the boundaries of separate departments, or to join disk groups when departments are merged.
- To isolate volumes or disks from a disk group, and process them independently on the same host or on a different host. This allows you to implement off-host processing solutions for the purposes of backup or decision support. See [“About off-host processing solutions”](#) on page 455.
- To reduce the size of a disk group's configuration database in the event that its private region is nearly full. This is a much simpler solution than the alternative of trying to grow the private region.
- To perform online maintenance and upgrading of fault-tolerant systems that can be split into separate hosts for this purpose, and then rejoined.



Use the `vxchg` command to reorganize your disk groups.

The `vxchg` command provides the following operations for reorganizing disk groups:

- `move` moves a self-contained set of VxVM objects between imported disk groups. This operation fails if it would remove all the disks from the source disk group. Volume states are preserved across the move.

Figure 5-4 shows the `move` operation.

**Figure 5-4** Disk group move operation

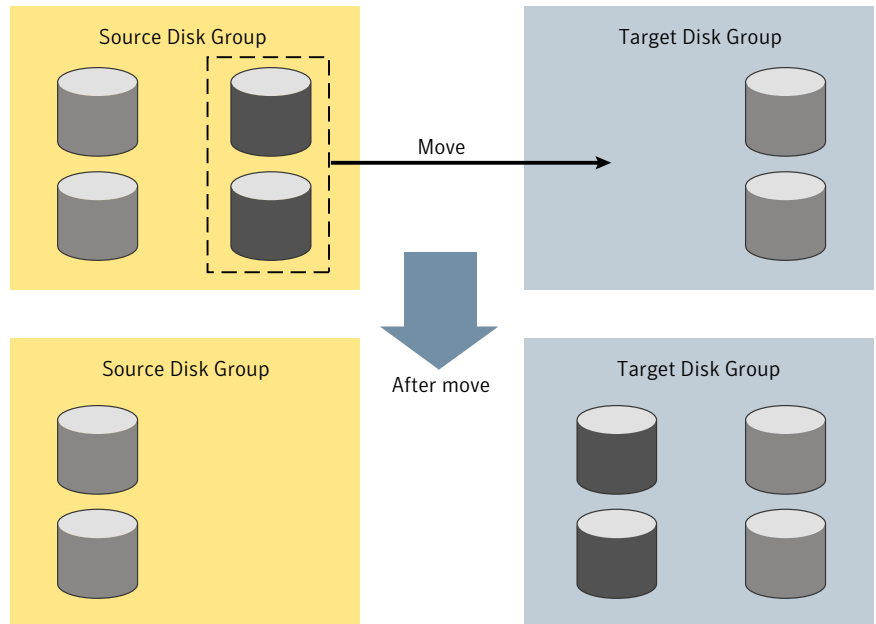

- `split` removes a self-contained set of VxVM objects from an imported disk group, and moves them to a newly created target disk group. This operation fails if it would remove all the disks from the source disk group, or if an imported disk group exists with the same name as the target disk group. An existing deported disk group is destroyed if it has the same name as the target disk group (as is the case for the `vxchg init` command).

Figure 5-5 shows the `split` operation.

**Figure 5-5** Disk group split operation

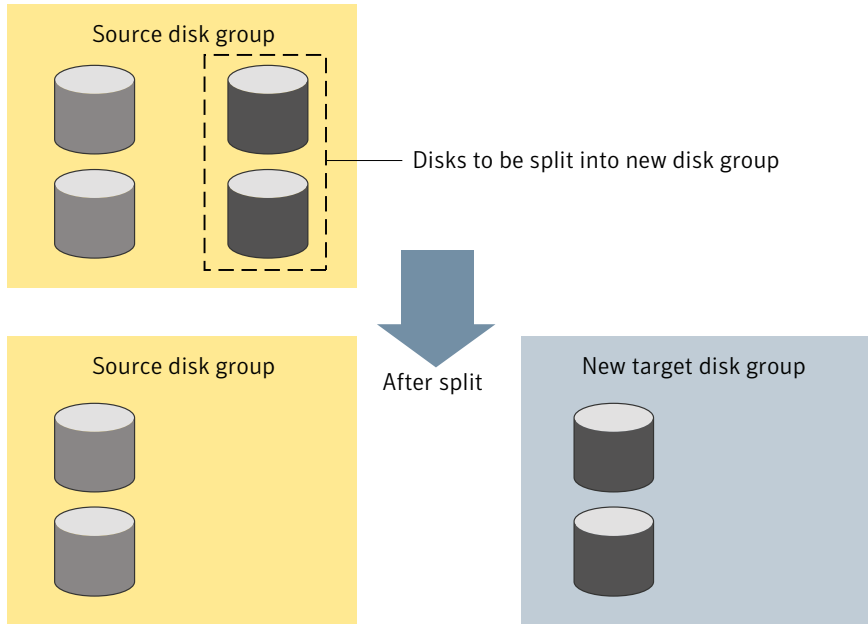

- `join` removes all VxVM objects from an imported disk group and moves them to an imported target disk group. The source disk group is removed when the join is complete.

Figure 5-6 shows the `join` operation.

**Figure 5-6** Disk group join operation

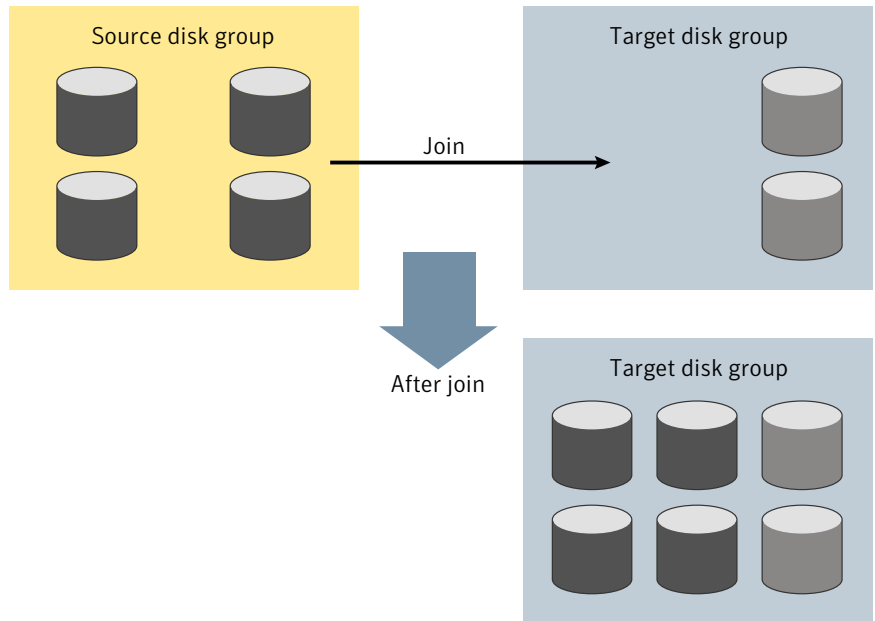

These operations are performed on VxVM objects such as disks or top-level volumes, and include all component objects such as sub-volumes, plexes and subdisks. The objects to be moved must be self-contained, meaning that the disks that are moved must not contain any other objects that are not intended for the move.

If you specify one or more disks to be moved, all VxVM objects on the disks are moved. You can use the `-o expand` option to ensure that `vxchg` moves all disks on which the specified objects are configured. Take care when doing this as the result may not always be what you expect. You can use the `listmove` operation with `vxchg` to help you establish what is the self-contained set of objects that corresponds to a specified set of objects.

---

**Warning:** Before moving volumes between disk groups, stop all applications that are accessing the volumes, and unmount all file systems that are configured on these volumes.

---

If the system crashes or a hardware subsystem fails, VxVM attempts to complete or reverse an incomplete disk group reconfiguration when the system is restarted or the hardware subsystem is repaired, depending on how far the reconfiguration had progressed. If one of the disk groups is no longer available because it has been

imported by another host or because it no longer exists, you must recover the disk group manually.

See the *Veritas Volume Manager Troubleshooting Guide*.

## Limitations of disk group split and join

The disk group split and join feature has the following limitations:

- Disk groups involved in a move, split or join must be version 90 or greater. See “[Upgrading a disk group](#)” on page 270.
- The reconfiguration must involve an integral number of physical disks.
- Objects to be moved must not contain open volumes.
- Disks cannot be moved between CDS and non-CDS compatible disk groups.
- Moved volumes are initially disabled following a disk group move, split or join. Use the `vxrecover -m` and `vxvol startall` commands to recover and restart the volumes.
- Data change objects (DCOs) and snap objects that have been dissociated by Persistent FastResync cannot be moved between disk groups.
- Veritas Volume Replicator (VVR) objects cannot be moved between disk groups.
- For a disk group move to succeed, the source disk group must contain at least one disk that can store copies of the configuration database after the move.
- For a disk group split to succeed, both the source and target disk groups must contain at least one disk that can store copies of the configuration database after the split.
- For a disk group move or join to succeed, the configuration database in the target disk group must be able to accommodate information about all the objects in the enlarged disk group.
- Splitting or moving a volume into a different disk group changes the volume’s record ID.
- The operation can only be performed on the master node of a cluster if either the source disk group or the target disk group is shared.
- In a cluster environment, disk groups involved in a move or join must both be private or must both be shared.
- If a cache object or volume set that is to be split or moved uses ISP volumes, the storage pool that contains these volumes must also be specified.

## Listing objects potentially affected by a move

To display the VxVM objects that would be moved for a specified list of objects, use the following command:

```
# vxdg [-o expand] listmove sourcedg targetdg object ...
```

The following example lists the objects that would be affected by moving volume `vol1` from disk group `mydg` to `newdg`:

```
# vxdg listmove mydg newdg vol1
mydg01 c0t1d0s2 mydg05 c1t96d0s2 vol1 vol1-01 vol1-02 mydg01-01
mydg05-01
```

However, the following command produces an error because only a part of the volume `vol1` is configured on the disk `mydg01`:

```
# vxdg listmove mydg newdg mydg01
VxVM vxdg ERROR V-5-2-4597 vxdg listmove mydg newdg failed
VxVM vxdg ERROR V-5-2-3091 mydg05 : Disk not moving, but
subdisks on it are
```

Specifying the `-o expand` option, as shown below, ensures that the list of objects to be moved includes the other disks (in this case, `mydg05`) that are configured in `vol1`:

```
# vxdg -o expand listmove mydg newdg mydg01
mydg01 c0t1d0s2 mydg05 c1t96d0s2 vol1 vol1-01 vol1-02 mydg01-01 mydg05-01
```

## Moving DCO volumes between disk groups

When you move the parent volume (such as a snapshot volume) to a different disk group, its DCO volume must accompany it. If you use the `vxassist addlog`, `vxmake` or `vxdcg` commands to set up a DCO for a volume, you must ensure that the disks that contain the plexes of the DCO volume accompany their parent volume during the move. You can use the `vxprint` command on a volume to examine the configuration of its associated DCO volume.

If you use the `vxassist` command to create both a volume and its DCO, or the `vxsnap prepare` command to add a DCO to a volume, the DCO plexes are automatically placed on different disks from the data plexes of the parent volume. In previous releases, version 0 DCO plexes were placed on the same disks as the data plexes for convenience when performing disk group split and move operations. As version 20 DCOs support dirty region logging (DRL) in addition to Persistent FastResync, it is preferable for the DCO plexes to be separated from the data

plexes. This improves the performance of I/O from/to the volume, and provides resilience for the DRL logs.

[Figure 5-7](#) shows some instances in which it is not possible to split a disk group because of the location of the DCO plexes on the disks of the disk group.

See [“Specifying storage for version 0 DCO plexes”](#) on page 442.

See [“Specifying storage for version 20 DCO plexes”](#) on page 362.

See [“FastResync”](#) on page 64.

See [“Volume snapshots”](#) on page 62.

**Figure 5-7** Examples of disk groups that can and cannot be split

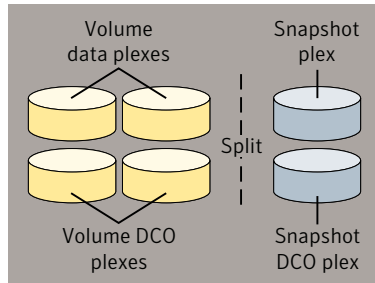

The disk group can be split as the DCO plexes are on dedicated disks, and can therefore accompany the disks that contain the volume data

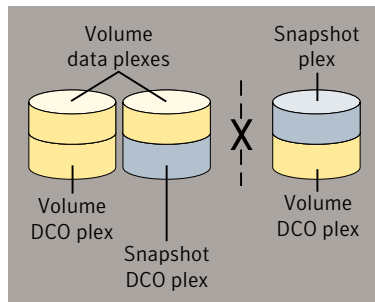

The disk group cannot be split as the DCO plexes cannot accompany their volumes. One solution is to relocate the DCO plexes. In this example, use an additional disk in the disk group as an intermediary to swap the misplaced DCO plexes. Alternatively, to improve DRL performance and resilience, allocate the DCO plexes to dedicated disks.

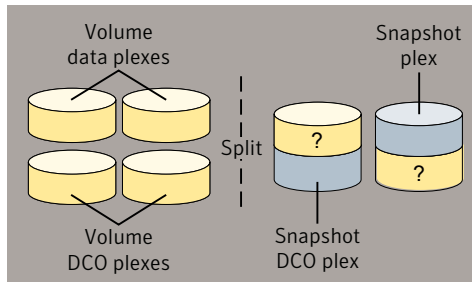

The disk group can be split as the DCO plexes can accompany their volumes. However, you may not wish the data in the portions of the disks marked "?" to be moved as well.

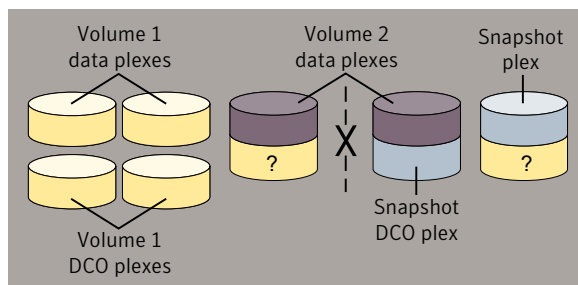

The disk group cannot be split as this would separate the disks containing Volume 2's data plexes. Possible solutions are to relocate the snapshot DCO plex to the snapshot plex disk, or to another suitable disk that can be moved.

## Moving objects between disk groups

To move a self-contained set of VxVM objects from an imported source disk group to an imported target disk group, use the following command:

```
# vxdg [-o expand] [-o override|verify] move sourcedg targetdg \  

  object ...
```

The `-o expand` option ensures that the objects that are actually moved include all other disks containing subdisks that are associated with the specified objects or with objects that they contain.

The default behavior of `vxdg` when moving licensed disks in an EMC array is to perform an EMC disk compatibility check for each disk involved in the move. If the compatibility checks succeed, the move takes place. `vxdg` then checks again to ensure that the configuration has not changed since it performed the compatibility check. If the configuration has changed, `vxdg` attempts to perform the entire move again.

---

**Note:** You should only use the `-o override` and `-o verify` options if you are using an EMC array with a valid timefinder license. If you specify one of these options and do not meet the array and license requirements, a warning message is displayed and the operation is ignored.

---

The `-o override` option enables the move to take place without any EMC checking.

The `-o verify` option returns the access names of the disks that would be moved but does not perform the move.

The following output from `vxprint` shows the contents of disk groups `rootdg` and `mydg`.

The output includes two utility fields, `TUTILO` and `PUTILO`. VxVM creates these fields to manage objects and communications between different commands and Symantec products. The `TUTILO` values are temporary; they are not maintained on reboot. The `PUTILO` values are persistent; they are maintained on reboot.

See [“Changing subdisk attributes”](#) on page 287.

```
# vxprint
Disk group: rootdg
TY NAME      ASSOC      KSTATE    LENGTH    PLOFFS    STATE     TUTILO    PUTILO
dg rootdg    rootdg     -         -         -         -         -         -
dm rootdg02  clt97d0s2 -         17678493 -         -         -         -
dm rootdg03  clt112d0s2 -         17678493 -         -         -         -
dm rootdg04  clt114d0s2 -         17678493 -         -         -         -
dm rootdg06  clt98d0s2 -         17678493 -         -         -         -

Disk group: mydg
TY NAME      ASSOC      KSTATE    LENGTH    PLOFFS    STATE     TUTILO    PUTILO
```



dg mydg	mydg	-	-	-	-	-	-
dm mydg01	c0t1d0s2	-	17678493	-	-	-	-
dm mydg05	clt96d0s2	-	17678493	-	-	-	-
dm mydg07	clt99d0s2	-	17678493	-	-	-	-
dm mydg08	clt100d0s2	-	17678493	-	-	-	-
v vol1	fsgen	ENABLED	2048	-	ACTIVE	-	-
pl vol1-01	vol1	ENABLED	3591	-	ACTIVE	-	-
sd mydg01-01	vol1-01	ENABLED	3591	0	-	-	-
pl vol1-02	vol1	ENABLED	3591	-	ACTIVE	-	-
sd mydg05-01	vol1-02	ENABLED	3591	0	-	-	-

The following command moves the self-contained set of objects implied by specifying disk `mydg01` from disk group `mydg` to `rootdg`:

```
# vxvg -o expand move mydg rootdg mydg01
```

The moved volumes are initially disabled following the move. Use the following commands to recover and restart the volumes in the target disk group:

```
# vxrecover -g targetdg -m [volume ...]
# vxvol -g targetdg startall
```

The output from `vxprint` after the move shows that not only `mydg01` but also volume `vol1` and `mydg05` have moved to `rootdg`, leaving only `mydg07` and `mydg08` in disk group `mydg`:

```
# vxprint
Disk group: rootdg
TY NAME      ASSOC      KSTATE    LENGTH    PLOFFS    STATE     TUTILO    PUTILO
dg rootdg    rootdg     -          -          -          -          -
dm mydg01    c0t1d0s2  -          17678493  -          -          -
dm rootdg02  clt97d0s2 -          17678493  -          -          -
dm rootdg03  clt112d0s2 -          17678493  -          -          -
dm rootdg04  clt114d0s2 -          17678493  -          -          -
dm mydg05    clt96d0s2 -          17678493  -          -          -
dm rootdg06  clt98d0s2 -          17678493  -          -          -
v vol1       fsgen      ENABLED    2048      -          ACTIVE    -          -
pl vol1-01   vol1       ENABLED    3591      -          ACTIVE    -          -
sd mydg01-01 vol1-01    ENABLED    3591      0          -          -          -
pl vol1-02   vol1       ENABLED    3591      -          ACTIVE    -          -
sd mydg05-01 vol1-02    ENABLED    3591      0          -          -          -

Disk group: mydg
TY NAME      ASSOC      KSTATE    LENGTH    PLOFFS    STATE     TUTILO    PUTILO
dg mydg      mydg       -          -          -          -          -
```

```
dm mydg07      clt99d0s2 -          17678493 -          -          -          -
dm mydg08      clt100d0s2 -         17678493 -          -          -          -
```

The following commands would also achieve the same result:

```
# vxvg move mydg rootdg mydg01 mydg05
# vxvg move mydg rootdg voll
```

See [“Moving objects between shared disk groups”](#) on page 519.

## Splitting disk groups

To remove a self-contained set of VxVM objects from an imported source disk group to a new target disk group, use the following command:

```
# vxvg [-o expand] [-o override|verify] split sourcedg targetdg \  

  object ...
```

See [“Moving objects between disk groups”](#) on page 263.

The following output from `vxprint` shows the contents of disk group `rootdg`.

The output includes two utility fields, `TUTIL0` and `PUTIL0`. VxVM creates these fields to manage objects and communications between different commands and Symantec products. The `TUTIL0` values are temporary; they are not maintained on reboot. The `PUTIL0` values are persistent; they are maintained on reboot.

See [“Changing subdisk attributes”](#) on page 287.

```
# vxprint
Disk group: rootdg
TY NAME          ASSOC      KSTATE    LENGTH    PLOFFS    STATE     TUTIL0    PUTIL0
dg rootdg        rootdg     -          -          -          -          -          -
dm rootdg01      c0t1d0s2  -          17678493  -          -          -          -
dm rootdg02      clt97d0s2 -          17678493  -          -          -          -
dm rootdg03      clt112d0s2 -         17678493  -          -          -          -
dm rootdg04      clt114d0s2 -         17678493  -          -          -          -
dm rootdg05      clt96d0s2 -          17678493  -          -          -          -
dm rootdg06      clt98d0s2 -          17678493  -          -          -          -
dm rootdg07      clt99d0s2 -          17678493  -          -          -          -
dm rootdg08      clt100d0s2 -         17678493  -          -          -          -
v  voll          fsgen     ENABLED    2048      -          ACTIVE    -          -
pl  voll-01      voll      ENABLED    3591      -          ACTIVE    -          -
sd  rootdg01-01 voll-01    ENABLED    3591      0          -          -          -
pl  voll-02      voll      ENABLED    3591      -          ACTIVE    -          -
sd  rootdg05-01 voll-02    ENABLED    3591      0          -          -          -
```

The following command removes disks `rootdg07` and `rootdg08` from `rootdg` to form a new disk group, `mydg`:

```
# vxdg -o expand split rootdg mydg rootdg07 rootdg08
```

The moved volumes are initially disabled following the split. Use the following commands to recover and restart the volumes in the new target disk group:

```
# vxrecover -g targetdg -m [volume ...]
# vxvol -g targetdg startall
```

The output from `vxprint` after the split shows the new disk group, `mydg`:

```
# vxprint
Disk group: rootdg
TY NAME      ASSOC      KSTATE     LENGTH     PLOFFS     STATE      TUTILO     PUTILO
dg rootdg    rootdg     -          -          -          -          -
dm rootdg01  c0t1d0s2  -          17678493  -          -          -
dm rootdg02  clt97d0s2 -          17678493  -          -          -
dm rootdg03  clt112d0s2- 17678493  -          -          -
dm rootdg04  clt114d0s2- 17678493  -          -          -
dm rootdg05  clt96d0s2  -          17678493  -          -          -
dm rootdg06  clt98d0s2  -          17678493  -          -          -
v  vol1      fsgen     ENABLED    2048      -          ACTIVE    -
pl  vol1-01   vol1      ENABLED    3591      -          ACTIVE    -
sd  rootdg01-01 vol1-01  ENABLED    3591      0          -          -
pl  vol1-02   vol1      ENABLED    3591      -          ACTIVE    -
sd  rootdg05-01 vol1-02  ENABLED    3591      0          -          -

Disk group: mydg
TY NAME      ASSOC      KSTATE     LENGTH     PLOFFS     STATE      TUTILO     PUTILO
dg mydg      mydg       -          -          -          -          -
dm rootdg07  clt99d0s2 -          17678493  -          -          -
dm rootdg08  clt100d0s2- 17678493  -          -          -
```

See [“Splitting shared disk groups”](#) on page 519.

## Joining disk groups

To remove all VxVM objects from an imported source disk group to an imported target disk group, use the following command:

```
# vxdg [-o override|verify] join sourcedg targetdg
```

See [“Moving objects between disk groups”](#) on page 263.

---

**Note:** You cannot specify `rootdg` as the source disk group for a `join` operation.

---

The following output from `vxprint` shows the contents of the disk groups `rootdg` and `mydg`.

The output includes two utility fields, `TUTILO` and `PUTILO`. VxVM creates these fields to manage objects and communications between different commands and Symantec products. The `TUTILO` values are temporary; they are not maintained on reboot. The `PUTILO` values are persistent; they are maintained on reboot.

See “[Changing subdisk attributes](#)” on page 287.

```
# vxprint
Disk group: rootdg
TY NAME      ASSOC      KSTATE      LENGTH      PLOFFS      STATE      TUTILO      PUTILO
dg rootdg    rootdg     -            -            -            -            -
dm rootdg01  c0t1d0s2  -            17678493    -            -            -
dm rootdg02  c1t97d0s2 -            17678493    -            -            -
dm rootdg03  c1t112d0s2 -            17678493    -            -            -
dm rootdg04  c1t114d0s2 -            17678493    -            -            -
dm rootdg07  c1t99d0s2 -            17678493    -            -            -
dm rootdg08  c1t100d0s2 -            17678493    -            -            -

Disk group: mydg
TY NAME      ASSOC      KSTATE      LENGTH      PLOFFS      STATE      TUTILO      PUTILO
dg mydg      mydg       -            -            -            -            -
dm mydg05    c1t96d0s2 -            17678493    -            -            -
dm mydg06    c1t98d0s2 -            17678493    -            -            -
v  voll      fsgen      ENABLED      2048        -            ACTIVE     -            -
pl  voll-01   voll       ENABLED      3591        -            ACTIVE     -            -
sd mydg01-01 voll-01     ENABLED      3591        0            -            -            -
pl  voll-02   voll       ENABLED      3591        -            ACTIVE     -            -
sd mydg05-01 voll-02     ENABLED      3591        0            -            -            -
```

The following command joins disk group `mydg` to `rootdg`:

```
# vxdg join mydg rootdg
```

The moved volumes are initially disabled following the join. Use the following commands to recover and restart the volumes in the target disk group:

```
# vxrecover -g targetdg -m [volume ...]
# vxvol -g targetdg startall
```

The output from `vxprint` after the join shows that disk group `mydg` has been removed:

```
# vxprint
Disk group: rootdg
TY NAME      ASSOC      KSTATE      LENGTH      PLOFFS      STATE      TUTILO      PUTILO
dg rootdg    rootdg     -            -            -            -            -
dm mydg01    c0t1d0s2  -            17678493    -            -            -            -
dm rootdg02  c1t97d0s2 -            17678493    -            -            -            -
dm rootdg03  c1t112d0s2 -            17678493    -            -            -            -
dm rootdg04  c1t114d0s2 -            17678493    -            -            -            -
dm mydg05    c1t96d0s2 -            17678493    -            -            -            -
dm rootdg06  c1t98d0s2 -            17678493    -            -            -            -
dm rootdg07  c1t99d0s2 -            17678493    -            -            -            -
dm rootdg08  c1t100d0s2 -            17678493    -            -            -            -
v  vol1      fsgen      ENABLED      2048         -            ACTIVE      -            -
pl  vol1-01   vol1       ENABLED      3591         -            ACTIVE      -            -
sd  mydg01-01 vol1-01    ENABLED      3591         0            -            -            -
pl  vol1-02   vol1       ENABLED      3591         -            ACTIVE      -            -
sd  mydg05-01 vol1-02    ENABLED      3591         0            -            -            -
```

See [“Joining shared disk groups”](#) on page 520.

## Disabling a disk group

To disable a disk group, unmount and stop any volumes in the disk group, and then use the following command to deport it:

```
# vxdg deport diskgroup
```

Deporting a disk group does not actually remove the disk group. It disables use of the disk group by the system. Disks in a deported disk group can be reused, reinitialized, added to other disk groups, or imported for use on other systems. Use the `vxdg import` command to re-enable access to the disk group.

## Destroying a disk group

The `vxdg` command provides a `destroy` option that removes a disk group from the system and frees the disks in that disk group for reinitialization:

```
# vxdg destroy diskgroup
```

---

**Warning:** This command destroys all data on the disks.

---

When a disk group is destroyed, the disks that are released can be re-used in other disk groups.

## Recovering a destroyed disk group

If a disk group has been accidentally destroyed, you can recover it, provided that the disks that were in the disk group have not been modified or reused elsewhere.

### To recover a destroyed disk group

- 1 Enter the following command to find out the disk group ID (*dgid*) of one of the disks that was in the disk group:

```
# vxdisk -s list disk_access_name
```

The disk must be specified by its disk access name, such as `c0t12d0s2`.

Examine the output from the command for a line similar to the following that specifies the disk group ID.

```
dgid:    963504895.1075.bass
```

- 2 Use the disk group ID to import the disk group:

```
# vxdg import dgid
```

## Upgrading a disk group

Prior to the release of Veritas Volume Manager 3.0, the disk group version was automatically upgraded (if needed) when the disk group was imported.

---

**Note:** On some platforms, the first release of Veritas Volume Manager was 3.0 or 3.2.

---

From release 3.0 of Veritas Volume Manager, the two operations of importing a disk group and upgrading its version are separate. You can import a disk group from a previous version and use it without upgrading it.

When you want to use new features, the disk group can be upgraded. The upgrade is an explicit operation. Once the upgrade occurs, the disk group becomes incompatible with earlier releases of VxVM that do not support the new version.

Until the disk group is upgraded, it may still be deported back to the release from which it was imported.

Until completion of the upgrade, the disk group can be used “as is” provided there is no attempt to use the features of the current version. There is no "downgrade" facility. For disk groups which are shared among multiple servers for failover or for off-host processing, verify that the VxVM release on all potential hosts that may use the disk group supports the diskgroup version to which you are upgrading.

Attempts to use a feature of the current version that is not a feature of the version from which the disk group was imported results in an error message similar to this:

```
VxVM vxedit ERROR V-5-1-2829 Disk group version doesn't support feature
```

To use any of the new features, you must run the `vxchg upgrade` command to explicitly upgrade the disk group to a version that supports those features.

All disk groups have a version number associated with them. Veritas Volume Manager releases support a specific set of disk group versions. VxVM can import and perform operations on a disk group of that version. The operations are limited by what features and operations the disk group version supports.

**Table 5-1** summarizes the Veritas Volume Manager releases that introduce and support specific disk group versions.

**Table 5-1** Disk group version assignments

VxVM release	Introduces disk group version	Supports disk group versions
1.2	10	10
1.3	15	15
2.0	20	20
2.2	30	30
2.3	40	40
2.5	50	50
3.0	60	20-40, 60
3.1	70	20-70
3.1.1	80	20-80
3.2, 3.5	90	20-90

**Table 5-1** Disk group version assignments (*continued*)

VxVM release	Introduces disk group version	Supports disk group versions
4.0	110	20-110
4.1	120	20-120
5.0	140	20-140
5.1	150	20-150

Importing the disk group of a previous version on a Veritas Volume Manager system prevents the use of features introduced since that version was released.

[Table 5-2](#) summarizes the features that are supported by disk group versions 20 through 150.

**Table 5-2** Features supported by disk group versions

Disk group version	New features supported	Previous version features supported
150	SSD device support, migration of ISP dg	20, 30, 40, 50, 60, 70, 80, 90, 110, 120, 130, 140
140	Data migration, Remote Mirror, coordinator disk groups (used by VCS), linked volumes, snapshot LUN import.	20, 30, 40, 50, 60, 70, 80, 90, 110, 120, 130
130	<ul style="list-style-type: none"> <li>■ VVR Enhancements</li> </ul>	20, 30, 40, 50, 60, 70, 80, 90, 110, 120
120	<ul style="list-style-type: none"> <li>■ Automatic Cluster-wide Failback for A/P arrays</li> <li>■ Persistent DMP Policies</li> <li>■ Shared Disk Group Failure Policy</li> </ul>	20, 30, 40, 50, 60, 70, 80, 90, 110



**Table 5-2** Features supported by disk group versions (*continued*)

Disk group version	New features supported	Previous version features supported
110	<ul style="list-style-type: none"> <li>■ Cross-platform Data Sharing (CDS)</li> <li>■ Device Discovery Layer (DDL) 2.0</li> <li>■ Disk Group Configuration Backup and Restore</li> <li>■ Elimination of <code>rootdg</code> as a Special Disk Group</li> <li>■ Full-Sized and Space-Optimized Instant Snapshots</li> <li>■ Intelligent Storage Provisioning (ISP)</li> <li>■ Serial Split Brain Detection</li> <li>■ Volume Sets (Multiple Device Support for VxFS)</li> </ul>	20, 30, 40, 50, 60, 70, 80, 90
90	<ul style="list-style-type: none"> <li>■ Cluster Support for Oracle Resilvering</li> <li>■ Disk Group Move, Split and Join</li> <li>■ Device Discovery Layer (DDL) 1.0</li> <li>■ Layered Volume Support in Clusters</li> <li>■ Ordered Allocation</li> <li>■ OS Independent Naming Support</li> <li>■ Persistent FastResync</li> </ul>	20, 30, 40, 50, 60, 70, 80
80	<ul style="list-style-type: none"> <li>■ VVR Enhancements</li> </ul>	20, 30, 40, 50, 60, 70
70	<ul style="list-style-type: none"> <li>■ Non-Persistent FastResync</li> <li>■ Sequential DRL</li> <li>■ Unrelocate</li> <li>■ VVR Enhancements</li> </ul>	20, 30, 40, 50, 60
60	<ul style="list-style-type: none"> <li>■ Online Relayout</li> <li>■ Safe RAID-5 Subdisk Moves</li> </ul>	20, 30, 40

**Table 5-2** Features supported by disk group versions (*continued*)

Disk group version	New features supported	Previous version features supported
50	<ul style="list-style-type: none"> <li>■ SRVM (now known as Veritas Volume Replicator or VVR)</li> </ul>	20, 30, 40
40	<ul style="list-style-type: none"> <li>■ Hot-Relocation</li> </ul>	20, 30
30	<ul style="list-style-type: none"> <li>■ VxSmartSync Recovery Accelerator</li> </ul>	20
20	<ul style="list-style-type: none"> <li>■ Dirty Region Logging (DRL)</li> <li>■ Disk Group Configuration Copy Limiting</li> <li>■ Mirrored Volumes Logging</li> <li>■ New-Style Stripes</li> <li>■ RAID-5 Volumes</li> <li>■ Recovery Checkpointing</li> </ul>	

To list the version of a disk group, use this command:

```
# vxdg list dgname
```

You can also determine the disk group version by using the `vxprint` command with the `-l` format option.

To upgrade a disk group to the highest version supported by the release of VxVM that is currently running, use this command:

```
# vxdg upgrade dgname
```

By default, VxVM creates a disk group of the highest version supported by the release. For example, Veritas Volume Manager 5.1 creates disk groups with version 150.

It may sometimes be necessary to create a disk group for an older version. The default disk group version for a disk group created on a system running Veritas Volume Manager 5.1 is 150. Such a disk group cannot be imported on a system running Veritas Volume Manager 4.1, as that release only supports up to version 120. Therefore, to create a disk group on a system running Veritas Volume Manager 5.1 that can be imported by a system running Veritas Volume Manager 4.1, the disk group must be created with a version of 120 or less.

To create a disk group with a previous version, specify the `-T version` option to the `vxdg init` command.

For example, to create a disk group with version 120 that can be imported by a system running VxVM 4.1, use the following command:

```
# vxrdg -T 120 init newdg newdg01=c0t3d0s2
```

This creates a disk group, `newdg`, which can be imported by Veritas Volume Manager 4.1. Note that while this disk group can be imported on the VxVM 4.1 system, attempts to use features from Veritas Volume Manager 5.0 and later releases will fail.

## Managing the configuration daemon in VxVM

The VxVM configuration daemon (`vxconfigd`) provides the interface between VxVM commands and the kernel device drivers. `vxconfigd` handles configuration change requests from VxVM utilities, communicates the change requests to the VxVM kernel, and modifies configuration information stored on disk. `vxconfigd` also initializes VxVM when the system is booted.

The `vxdtl` command is the command-line interface to the `vxconfigd` daemon.

You can use `vxdtl` to:

- Control the operation of the `vxconfigd` daemon.
- Change the system-wide definition of the default disk group.

In VxVM 4.0 and later releases, disk access records are no longer stored in the `/etc/vx/volboot` file. Non-persistent disk access records are created by scanning the disks at system startup. Persistent disk access records for `simple` and `nopriv` disks are permanently stored in the `/etc/vx/darecs` file in the `root` file system. The `vxconfigd` daemon reads the contents of this file to locate the disks and the configuration databases for their disk groups.

The `/etc/vx/darecs` file is also used to store definitions of foreign devices that are not autoconfigurable. Such entries may be added by using the `vxddladm addforeign` command.

See the `vxddladm(1M)` manual page.

If your system is configured to use Dynamic Multipathing (DMP), you can also use `vxdtl` to:

- Reconfigure the DMP database to include disk devices newly attached to, or removed from the system.
- Create DMP device nodes in the `/dev/vx/dmp` and `/dev/vx/rdmp` directories.

- Update the DMP database with changes in path type for active/passive disk arrays. Use the utilities provided by the disk-array vendor to change the path type between primary and secondary.

See the `vxdtl(1M)` manual page.

## Backing up and restoring disk group configuration data

The disk group configuration backup and restoration feature allows you to back up and restore all configuration data for disk groups, and for VxVM objects such as volumes that are configured within the disk groups. The `vxconfigbackupd` daemon monitors changes to the VxVM configuration and automatically records any configuration changes that occur. Two utilities, `vxconfigbackup` and `vxconfigrestore`, are provided for backing up and restoring a VxVM configuration for a disk group.

See the *Veritas Volume Manager Troubleshooting Guide*.

See the `vxconfigbackup(1M)` manual page.

See the `vxconfigrestore(1M)` manual page.

## Using `vxnotify` to monitor configuration changes

You can use the `vxnotify` utility to display events relating to disk and configuration changes that are managed by the `vxconfigd` configuration daemon. If `vxnotify` is running on a system where the VxVM clustering feature is active, it displays events that are related to changes in the cluster state of the system on which it is running. The `vxnotify` utility displays the requested event types until you kill it, until it has received a specified number of events, or until a specified period of time has elapsed.

Examples of configuration events that can be detected include disabling and enabling of controllers, paths and DMP nodes, RAID-5 volumes entering degraded mode, detachment of disks, plexes and volumes, and nodes joining and leaving a cluster.

For example, the following `vxnotify` command displays information about all disk, plex, and volume detachments as they occur:

```
# vxnotify -f
```

The following command provides information about cluster configuration changes, including the import and deport of shared disk groups:

```
# vxnotify -s -I
```

See the `vxnotify(1M)` manual page.

## Working with ISP disk groups

The Intelligent Storage Provisioning (ISP) feature is supported up to 5.0 MP3 and has been deprecated from the VxVM 5.1 release. If you have any ISP disk groups, they can be imported using the following command:

```
# vxdg import ISP_diskgroup
```

To find out whether the disk group is an ISP disk group. You must check for the presence of storage pools using the following command:

```
# vxprint
```

Sample output:

```
Disk group: mydg
```

TY	NAME	ASSOC	KSTATE	LENGTH	PLOFFS	STATE	TUTILO	PUTILO
dg	mydg	mydg	-	-	-	ALLOC_SUP	-	-
dm	mydg2	ams_wms0_359	-	4120320	-	-	-	-
dm	mydg3	ams_wms0_360	-	4120320	-	-	-	-
st	mypool	-	-	-	-	DATA	-	-
dm	mydg1	ams_wms0_358	-	4120320	-	-	-	-
v	myvol0	fsgen	ENABLED	20480	-	ACTIVE	-	-
pl	myvol0-01	myvol0	ENABLED	20480	-	ACTIVE	-	-
sd	mydg1-01	myvol0-01	ENABLED	20480	0	-	-	-
v	myvol1	fsgen	ENABLED	20480	-	ACTIVE	-	-
pl	myvol1-01	myvol1	ENABLED	20480	-	ACTIVE	-	-
sd	mydg1-02	myvol1-01	ENABLED	20480	0	-	-	-

In the sample output, `st mypool` indicates that `mydg` is an ISP disk group.

The ISP volumes in the disk group are not allowed to make any configuration changes until it has been upgraded. Attempting any operations such as grow shrink, add mirror, disk group split join, etc, on ISP volumes would give the following error:

This disk group is a ISP disk group. Dg needs to be migrated to non-ISP dg to allow any configuration changes. Please upgrade the dg to perform the migration.

---

**Note:** Non-ISP or VxVM volumes in the ISP disk group are not affected.

---

The disk group can be upgraded using the following command:

```
# vxdg upgrade ISP_diskgroup
```

After upgrading ISP disk group, all ISP volumes are converted to non-ISP volumes and ISP-only objects are deleted. The ISP-only objects are st pool, volume template, capability, rules, etc. This operation does not affect non-ISP volumes.

Operations that still work on ISP disk group without upgrading:

- Setting, removing, and replacing volume tags.  
See “[About volume administration](#)” on page 338.
- Renaming of any VxVM objects such as volume, dg, plex, etc.
- Plex attach and detach.
- The `vxconfigbackup` and `vxconfigrestore` command can be used at the cost of losing any intent information

---

**Note:** By upgrading ISP disk group, all intent and storage pools information will be lost. The disk group should be upgraded only when this condition is acceptable.

---

# Creating and administering subdisks and plexes

This chapter includes the following topics:

- [About subdisks](#)
- [Creating subdisks](#)
- [Displaying subdisk information](#)
- [Moving subdisks](#)
- [Splitting subdisks](#)
- [Joining subdisks](#)
- [Associating subdisks with plexes](#)
- [Associating log subdisks](#)
- [Dissociating subdisks from plexes](#)
- [Removing subdisks](#)
- [Changing subdisk attributes](#)
- [About plexes](#)
- [Creating plexes](#)
- [Creating a striped plex](#)
- [Displaying plex information](#)
- [Attaching and associating plexes](#)

- [Taking plexes offline](#)
- [Detaching plexes](#)
- [Reattaching plexes](#)
- [Moving plexes](#)
- [Copying volumes to plexes](#)
- [Dissociating and removing plexes](#)
- [Changing plex attributes](#)

## About subdisks

Subdisks are the low-level building blocks in a Veritas Volume Manager (VxVM) configuration that are required to create plexes and volumes.

Subdisks are created automatically if you use the `vxassist` command.

See [“Creating a volume”](#) on page 307.

---

**Note:** Most VxVM commands require superuser or equivalent privileges.

---

## Creating subdisks

Use the `vxmake` command to create VxVM objects, such as subdisks:

```
# vxmake [-g diskgroup] sd subdisk diskname,offset,length
```

where *subdisk* is the name of the subdisk, *diskname* is the disk name, *offset* is the starting point (offset) of the subdisk within the disk, and *length* is the length of the subdisk.

For example, to create a subdisk named `mydg02-01` in the disk group, `mydg`, that starts at the beginning of disk `mydg02` and has a length of 8000 sectors, use the following command:

```
# vxmake -g mydg sd mydg02-01 mydg02,0,8000
```

---

**Note:** As for all VxVM commands, the default size unit is `s`, representing a sector. Add a suffix, such as `k` for kilobyte, `m` for megabyte or `g` for gigabyte, to change the unit of size. For example, `500m` would represent 500 megabytes.

---



If you intend to use the new subdisk to build a volume, you must associate the subdisk with a plex.

See “[Associating subdisks with plexes](#)” on page 283.

Subdisks for all plex layouts (concatenated, striped, RAID-5) are created the same way.

## Displaying subdisk information

The `vxprint` command displays information about VxVM objects. To display general information for all subdisks, use this command:

```
# vxprint -st
```

The `-s` option specifies information about subdisks. The `-t` option prints a single-line output record that depends on the type of object being listed.

The following is example output:

SD NAME	PLEX	DISK	DISKOFFS	LENGTH	[COL/]OFF	DEVICE	MODE
SV NAME	PLEX	VOLNAME	NVOLLAYR	LENGTH	[COL/]OFF	AM/NM	MODE
sd mydg01-01	vol1-01	mydg01	0	102400	0	c0t10d0	ENA
sd mydg02-01	vol2-01	mydg02	0	102400	0	c0t11d0	ENA

You can display complete information about a particular subdisk by using this command:

```
# vxprint [-g diskgroup] -l subdisk
```

For example, the following command displays all information for subdisk `mydg02-01` in the disk group, `mydg`:

```
# vxprint -g mydg -l mydg02-01
```

This command provides the following output:

```
Disk group: mydg

Subdisk: mydg02-01
info:    disk=mydg02 offset=0 len=205632
assoc:   vol=mvol plex=mvol-02 (offset=0)
flags:   enabled
device:  device=c0t11d0s2 path=/dev/vx/dmp/c0t11d0s2 diskdev=32/68
```

## Moving subdisks

Moving a subdisk copies the disk space contents of a subdisk onto one or more other subdisks. If the subdisk being moved is associated with a plex, then the data stored on the original subdisk is copied to the new subdisks. The old subdisk is dissociated from the plex, and the new subdisks are associated with the plex. The association is at the same offset within the plex as the source subdisk. To move a subdisk, use the following command:

```
# vxsd [-g diskgroup] mv old_subdisk new_subdisk [new_subdisk ...]
```

For example, if `mydg03` in the disk group, `mydg`, is to be evacuated, and `mydg12` has enough room on two of its subdisks, use the following command:

```
# vxsd -g mydg mv mydg03-01 mydg12-01 mydg12-02
```

For the subdisk move to work correctly, the following conditions must be met:

- The subdisks involved must be the same size.
- The subdisk being moved must be part of an active plex on an active (ENABLED) volume.
- The new subdisk must not be associated with any other plex.

Subdisk can also be moved manually after hot-relocation.

See “[Moving relocated subdisks](#)” on page 480.

## Splitting subdisks

Splitting a subdisk divides an existing subdisk into two separate subdisks. To split a subdisk, use the following command:

```
# vxsd [-g diskgroup] -s size split subdisk newsd1 newsd2
```

where *subdisk* is the name of the original subdisk, *newsd1* is the name of the first of the two subdisks to be created and *newsd2* is the name of the second subdisk to be created.

The `-s` option is required to specify the size of the first of the two subdisks to be created. The second subdisk occupies the remaining space used by the original subdisk.

If the original subdisk is associated with a plex before the task, upon completion of the split, both of the resulting subdisks are associated with the same plex.

To split the original subdisk into more than two subdisks, repeat the previous command as many times as necessary on the resulting subdisks.

For example, to split subdisk `mydg03-02`, with size 2000 megabytes into subdisks `mydg03-02`, `mydg03-03`, `mydg03-04` and `mydg03-05`, each with size 500 megabytes, all in the disk group, `mydg`, use the following commands:

```
# vxsd -g mydg -s 1000m split mydg03-02 mydg03-02 mydg03-04
# vxsd -g mydg -s 500m split mydg03-02 mydg03-02 mydg03-03
# vxsd -g mydg -s 500m split mydg03-04 mydg03-04 mydg03-05
```

## Joining subdisks

Joining subdisks combines two or more existing subdisks into one subdisk. To join subdisks, the subdisks must be contiguous on the same disk. If the selected subdisks are associated, they must be associated with the same plex, and be contiguous in that plex. To join several subdisks, use the following command:

```
# vxsd [-g diskgroup] join subdisk1 subdisk2 ... new_subdisk
```

For example, to join the contiguous subdisks `mydg03-02`, `mydg03-03`, `mydg03-04` and `mydg03-05` as subdisk `mydg03-02` in the disk group, `mydg`, use the following command:

```
# vxsd -g mydg join mydg03-02 mydg03-03 mydg03-04 mydg03-05 \
mydg03-02
```

## Associating subdisks with plexes

Associating a subdisk with a plex places the amount of disk space defined by the subdisk at a specific offset within the plex. The entire area that the subdisk fills must not be occupied by any portion of another subdisk. There are several ways that subdisks can be associated with plexes, depending on the overall state of the configuration.

If you have already created all the subdisks needed for a particular plex, to associate subdisks at plex creation, use the following command:

```
# vxmake [-g diskgroup] plex plex sd=subdisk,...
```

For example, to create the plex `home-1` and associate subdisks `mydg02-01`, `mydg02-00`, and `mydg02-02` with plex `home-1`, all in the disk group, `mydg`, use the following command:

```
# vxmake -g mydg plex home-1 sd=mydg02-01,mydg02-00,mydg02-02
```

Subdisks are associated in order starting at offset 0. If you use this type of command, you do not have to specify the multiple commands needed to create

the plex and then associate each of the subdisks with that plex. In this example, the subdisks are associated to the plex in the order they are listed (after `sd=`). The disk space defined as `mydg02-01` is first, `mydg02-00` is second, and `mydg02-02` is third. This method of associating subdisks is convenient during initial configuration.

Subdisks can also be associated with a plex that already exists. To associate one or more subdisks with an existing plex, use the following command:

```
# vxsd [-g diskgroup] assoc plex subdisk1 [subdisk2 subdisk3 ...]
```

For example, to associate subdisks named `mydg02-01`, `mydg02-00`, and `mydg02-02` with a plex named `home-1`, use the following command:

```
# vxsd -g mydg assoc home-1 mydg02-01 mydg02-00 mydg02-01
```

If the plex is not empty, the new subdisks are added after any subdisks that are already associated with the plex, unless the `-1` option is specified with the command. The `-1` option associates subdisks at a specific offset within the plex.

The `-1` option is required if you previously created a sparse plex (that is, a plex with portions of its address space that do not map to subdisks) for a particular volume, and subsequently want to make the plex complete. To complete the plex, create a subdisk of a size that fits the hole in the sparse plex exactly. Then, associate the subdisk with the plex by specifying the offset of the beginning of the hole in the plex, using the following command:

```
# vxsd [-g diskgroup] -1 offset assoc sparse_plex exact_size_subdisk
```

For example, the following command would insert the subdisk, `mydg15-01`, in the plex, `vol110-01`, starting at an offset of 4096 blocks:

```
# vxsd -g mydg -1 4096b assoc vol110-01 mydg15-01
```

---

**Note:** The subdisk must be exactly the right size. VxVM does not allow the space defined for two subdisks to overlap within a plex.

---

For striped or RAID-5 plexes, use the following command to specify a column number and column offset for the subdisk to be added:

```
# vxsd [-g diskgroup] -1 column_#/offset assoc plex subdisk ...
```

If only one number is specified with the `-1` option for striped plexes, the number is interpreted as a column number and the subdisk is associated at the end of the column.

For example, the following command would add the subdisk, `mydg11-01`, to the end of column 1 of the plex, `vol102-01`:

```
# vxsd -g mydg -l 1 assoc vol102-01 mydg11-01
```

Alternatively, to add  $M$  subdisks at the end of each of the  $N$  columns in a striped or RAID-5 volume, you can use the following form of the `vxsd` command:

```
# vxsd [-g diskgroup] assoc plex subdisk1:0 ... subdiskM:N-1
```

The following example shows how to append three subdisk to the ends of the three columns in a striped plex, `vol1-01`, in the disk group, `mydg`:

```
# vxsd -g mydg assoc vol101-01 mydg10-01:0 mydg11-01:1 mydg12-01:2
```

If a subdisk is filling a “hole” in the plex (that is, some portion of the volume logical address space is mapped by the subdisk), the subdisk is considered stale. If the volume is enabled, the association operation regenerates data that belongs on the subdisk. Otherwise, it is marked as stale and is recovered when the volume is started.

## Associating log subdisks

Log subdisks are defined and added to a plex that is to become part of a volume on which dirty region logging (DRL) is enabled. DRL is enabled for a volume when the volume is mirrored and has at least one log subdisk.

---

**Warning:** Only one log subdisk can be associated with a plex. Because this log subdisk is frequently written, care should be taken to position it on a disk that is not heavily used. Placing a log subdisk on a heavily-used disk can degrade system performance.

---

See [“Dirty region logging”](#) on page 59.

See [“Dirty region logging in cluster environments”](#) on page 513.

Log subdisks are ignored as far as the usual plex policies are concerned, and are only used to hold the dirty region log.

---

**Warning:** The version 20 DCO volume layout includes space for a DRL. Do not use procedures that are intended for manipulating log subdisks with a volume that has a version 20 DCO volume associated with it.

---

See [“Preparing a volume for DRL and instant snapshots”](#) on page 360.

To add a log subdisk to an existing plex, use the following command:

```
# vxsd [-g diskgroup] aslog plex subdisk
```

where *subdisk* is the name to be used for the log subdisk. The plex must be associated with a mirrored volume before dirty region logging takes effect.

For example, to associate a subdisk named `mydg02-01` with a plex named `vol01-02`, which is already associated with volume `vol01` in the disk group, `mydg`, use the following command:

```
# vxsd -g mydg aslog vol01-02 mydg02-01
```

You can also add a log subdisk to an existing volume with the following command:

```
# vxassist [-g diskgroup] addlog volume disk
```

This command automatically creates a log subdisk within a log plex on the specified disk for the specified volume.

## Dissociating subdisks from plexes

To break an established connection between a subdisk and the plex to which it belongs, the subdisk is dissociated from the plex. A subdisk is dissociated when the subdisk is removed or used in another plex. To dissociate a subdisk, use the following command:

```
# vxsd [-g diskgroup] [-o force] dis subdisk
```

For example, to dissociate a subdisk named `mydg02-01` from the plex with which it is currently associated in the disk group, `mydg`, use the following command:

```
# vxsd -g mydg dis mydg02-01
```

You can additionally remove the dissociated subdisks from VxVM control using the following form of the command:

```
# vxsd [-g diskgroup] -o rm dis subdisk
```

---

**Warning:** If the subdisk maps a portion of a volume's address space, dissociating it places the volume in DEGRADED mode. In this case, the `dis` operation prints a warning and must be forced using the `-o force` option to succeed. Also, if removing the subdisk makes the volume unusable, because another subdisk in the same stripe is unusable or missing and the volume is not DISABLED and empty, the operation is not allowed.

---

## Removing subdisks

To remove a subdisk, use the following command:

```
# vxedit [-g diskgroup] rm subdisk
```

For example, to remove a subdisk named `mydg02-01` from the disk group, `mydg`, use the following command:

```
# vxedit -g mydg rm mydg02-01
```

## Changing subdisk attributes

---

**Warning:** To avoid possible data loss, change subdisk attributes with extreme care.

---

The `vxedit` command changes attributes of subdisks and other VxVM objects. To change subdisk attributes, use the following command:

```
# vxedit [-g diskgroup] set attribute=value ... subdisk ...
```

The subdisk fields you can change with the `vxedit` command include the following:

`name` Subdisk name.

`putiln` Persistent utility field(s) used to manage objects and communication between different commands and Symantec products.

`putiln` field attributes are maintained on reboot. `putiln` fields are organized as follows:

- `putil0` is set by VxVM.
- `putil1` is set by other Symantec products such as Storage Foundation Manager (SFM), or the Veritas Enterprise Administrator (VEA) console.
- `putil2` is available for you to set for site-specific purposes.

If a command is stopped in the middle of an operation, these fields may need to be cleaned up.

*tutiln* Nonpersistent (temporary) utility field(s) used to manage objects and communication between different commands and Symantec products.

*tutiln* field attributes are not maintained on reboot. *tutiln* fields are organized as follows:

- *tutil0* is set by VxVM.
- *tutil1* is set by other Symantec products such as Veritas Enterprise Administrator (VEA).
- *tutil2* is available for you to set for site-specific purposes.

If a command is stopped in the middle of an operation, these fields may need to be cleaned up.

*len* Subdisk length. This value is a standard Veritas Volume Manager length number. See the *vxintro(1M)* manual page.

You can only change the length of a subdisk if the subdisk is disassociated. You cannot increase the length of a subdisk to the point where it extends past the end of the disk or it overlaps a reserved disk region on another disk.

*comment* Comment.

For example, to change the comment field of a subdisk named `mydg02-01` in the disk group, `mydg`, use the following command:

```
# vxedit -g mydg set comment="subdisk comment" mydg02-01
```

To prevent a particular subdisk from being associated with a plex, set the `putil0` field to a non-null string, as shown in the following command:

```
# vxedit -g mydg set putil0="DO-NOT-USE" mydg02-01
```

See the *vxedit(1M)* manual page.

## About plexes

Plexes are logical groupings of subdisks that create an area of disk space independent of physical disk size or other restrictions. Replication (mirroring) of disk data is set up by creating multiple data plexes for a single volume. Each data plex in a mirrored volume contains an identical copy of the volume data. Because each data plex must reside on different disks from the other plexes, the replication provided by mirroring prevents data loss in the event of a single-point disk-subsystem failure. Multiple data plexes also provide increased data integrity and reliability.



Plexes are created automatically if you use the `vxassist` command to create volumes.

See [“About subdisks”](#) on page 280.

See [“Creating a volume”](#) on page 307.

---

**Note:** Most VxVM commands require superuser or equivalent privileges.

---

## Creating plexes

Use the `vxmake` command to create VxVM objects, such as plexes. When creating a plex, identify the subdisks that are to be associated with it:

To create a plex from existing subdisks, use the following command:

```
# vxmake [-g diskgroup] plex plex sd=subdisk1[,subdisk2,...]
```

For example, to create a concatenated plex named `vol101-02` from two existing subdisks named `mydg02-01` and `mydg02-02` in the disk group, `mydg`, use the following command:

```
# vxmake -g mydg plex vol101-02 sd=mydg02-01,mydg02-02
```

## Creating a striped plex

To create a striped plex, you must specify additional attributes. For example, to create a striped plex named `p1-01` in the disk group, `mydg`, with a stripe width of 32 sectors and 2 columns, use the following command:

```
# vxmake -g mydg plex p1-01 layout=stripe stwidth=32 ncolumn=2 \  
sd=mydg01-01,mydg02-01
```

To use a plex to build a volume, you must associate the plex with the volume.

See [“Attaching and associating plexes”](#) on page 294.

## Displaying plex information

Listing plexes helps identify free plexes for building volumes. Use the `plex (-p)` option to the `vxprint` command to list information about all plexes.

To display detailed information about all plexes in the system, use the following command:

```
# vxprint -lp
```

To display detailed information about a specific plex, use the following command:

```
# vxprint [-g diskgroup] -l plex
```

The `-t` option prints a single line of information about the plex. To list free plexes, use the following command:

```
# vxprint -pt
```

The following section describes the meaning of the various plex states that may be displayed in the STATE field of `vxprint` output.

## Plex states

Plex states reflect whether or not plexes are complete and are consistent copies (mirrors) of the volume contents. VxVM utilities automatically maintain the plex state. However, if a volume should not be written to because there are changes to that volume and if a plex is associated with that volume, you can modify the state of the plex. For example, if a disk with a particular plex located on it begins to fail, you can temporarily disable that plex.

A plex does not have to be associated with a volume. A plex can be created with the `vxmake plex` command and be attached to a volume later.

VxVM utilities use plex states to:

- indicate whether volume contents have been initialized to a known state
- determine if a plex contains a valid copy (mirror) of the volume contents
- track whether a plex was in active use at the time of a system failure
- monitor operations on plexes

This section explains the individual plex states in detail.

See the *Veritas Volume Manager Troubleshooting Guide*.

[Table 6-1](#) shows the states that may be associated with a plex.

**Table 6-1** Plex states

State	Description
ACTIVE	<p>A plex can be in the ACTIVE state in the following ways:</p> <ul style="list-style-type: none"> <li>■ when the volume is started and the plex fully participates in normal volume I/O (the plex contents change as the contents of the volume change)</li> <li>■ when the volume is stopped as a result of a system crash and the plex is ACTIVE at the moment of the crash</li> </ul> <p>In the latter case, a system failure can leave plex contents in an inconsistent state. When a volume is started, VxVM does the recovery action to guarantee that the contents of the plexes marked as ACTIVE are made identical.</p> <p>On a system that is running well, ACTIVE should be the most common state you see for any volume plexes.</p>
CLEAN	<p>A plex is in a CLEAN state when it is known to contain a consistent copy (mirror) of the volume contents and an operation has disabled the volume. As a result, when all plexes of a volume are clean, no action is required to guarantee that the plexes are identical when that volume is started.</p>
DCOSNP	<p>This state indicates that a data change object (DCO) plex attached to a volume can be used by a snapshot plex to create a DCO volume during a snapshot operation.</p>
EMPTY	<p>Volume creation sets all plexes associated with the volume to the EMPTY state to indicate that the plex is not yet initialized.</p>
IOFAIL	<p>The IOFAIL plex state is associated with persistent state logging. When the <code>vxconfigd</code> daemon detects an uncorrectable I/O failure on an ACTIVE plex, it places the plex in the IOFAIL state to exclude it from the recovery selection process at volume start time.</p> <p>This state indicates that the plex is out-of-date with respect to the volume, and that it requires complete recovery. It is likely that one or more of the disks associated with the plex should be replaced.</p>
LOG	<p>The state of a dirty region logging (DRL) or RAID-5 log plex is always set to LOG.</p>

**Table 6-1** Plex states (*continued*)

State	Description
OFFLINE	<p>The <code>vxmend off</code> task indefinitely detaches a plex from a volume by setting the plex state to OFFLINE. Although the detached plex maintains its association with the volume, changes to the volume do not update the OFFLINE plex. The plex is not updated until the plex is put online and reattached with the <code>vxplex att</code> task. When this occurs, the plex is placed in the STALE state, which causes its contents to be recovered at the next <code>vxvol start</code> operation.</p>
SNAPATT	<p>This state indicates a snapshot plex that is being attached by the <code>snapstart</code> operation. When the attach is complete, the state for the plex is changed to SNAPDONE. If the system fails before the attach completes, the plex and all of its subdisks are removed.</p>
SNAPDIS	<p>This state indicates a snapshot plex that is fully attached. A plex in this state can be turned into a snapshot volume with the <code>vxplex snapshot</code> command. If the system fails before the attach completes, the plex is dissociated from the volume.</p> <p>See the <code>vxplex(1M)</code> manual page.</p>
SNAPDONE	<p>The SNAPDONE plex state indicates that a snapshot plex is ready for a snapshot to be taken using <code>vxassist snapshot</code>.</p>
SNAPTMP	<p>The SNAPTMP plex state is used during a <code>vxassist snapstart</code> operation when a snapshot is being prepared on a volume.</p>
STALE	<p>If there is a possibility that a plex does not have the complete and current volume contents, that plex is placed in the STALE state. Also, if an I/O error occurs on a plex, the kernel stops using and updating the contents of that plex, and the plex state is set to STALE.</p> <p>A <code>vxplex att</code> operation recovers the contents of a STALE plex from an ACTIVE plex. Atomic copy operations copy the contents of the volume to the STALE plexes. The system administrator can force a plex to the STALE state with a <code>vxplex det</code> operation.</p>
TEMP	<p>Setting a plex to the TEMP state eases some plex operations that cannot occur in a truly atomic fashion. For example, attaching a plex to an enabled volume requires copying volume contents to the plex before it can be considered fully attached.</p> <p>A utility sets the plex state to TEMP at the start of such an operation and to an appropriate state at the end of the operation. If the system fails for any reason, a TEMP plex state indicates that the operation is incomplete. A later <code>vxvol start</code> dissociates plexes in the TEMP state.</p>

**Table 6-1** Plex states (*continued*)

State	Description
TEMPRM	<p>A TEMPRM plex state is similar to a TEMP state except that at the completion of the operation, the TEMPRM plex is removed. Some subdisk operations require a temporary plex. Associating a subdisk with a plex, for example, requires updating the subdisk with the volume contents before actually associating the subdisk. This update requires associating the subdisk with a temporary plex, marked TEMPRM, until the operation completes and removes the TEMPRM plex.</p> <p>If the system fails for any reason, the TEMPRM state indicates that the operation did not complete successfully. A later operation dissociates and removes TEMPRM plexes.</p>
TEMPRMSD	<p>The TEMPRMSD plex state is used by <code>vxassist</code> when attaching new data plexes to a volume. If the synchronization operation does not complete, the plex and its subdisks are removed.</p>

## Plex condition flags

[Table 6-2](#) shows the plex condition flags that `vxprint` may display in the STATE field.

**Table 6-2** Plex condition flags

Condition flag	Description
IOFAIL	<p>The plex was detached as a result of an I/O failure detected during normal volume I/O. The plex is out-of-date with respect to the volume, and in need of complete recovery. However, this condition also indicates a likelihood that one of the disks in the system should be replaced.</p>
NODAREC	<p>No physical disk was found for one of the subdisks in the plex. This implies either that the physical disk failed, making it unrecognizable, or that the physical disk is no longer attached through a known access path. The plex cannot be used until this condition is fixed, or the affected subdisk is dissociated.</p>
NODEVICE	<p>A physical device could not be found corresponding to the disk ID in the disk media record for one of the subdisks associated with the plex. The plex cannot be used until this condition is fixed, or the affected subdisk is dissociated.</p>

**Table 6-2** Plex condition flags (*continued*)

Condition flag	Description
RECOVER	A disk corresponding to one of the disk media records was replaced, or was reattached too late to prevent the plex from becoming out-of-date with respect to the volume. The plex required complete recovery from another plex in the volume to synchronize its contents.
REMOVED	Set in the disk media record when one of the subdisks associated with the plex is removed. The plex cannot be used until this condition is fixed, or the affected subdisk is dissociated.

## Plex kernel states

The plex kernel state indicates the accessibility of the plex to the volume driver which monitors it.

No user intervention is required to set these states; they are maintained internally. On a system that is operating properly, all plexes are enabled.

[Table 6-3](#) shows the possible plex kernel states.

**Table 6-3** Plex kernel states

Kernel state	Description
DETACHED	Maintenance is being performed on the plex. Any write request to the volume is not reflected in the plex. A read request from the volume is not satisfied from the plex. Plex operations and <code>ioctl</code> function calls are accepted.
DISABLED	The plex is offline and cannot be accessed.
ENABLED	The plex is online. A write request to the volume is reflected in the plex. A read request from the volume is satisfied from the plex. If a plex is sparse, this is indicated by the <code>SPARSE</code> modifier being displayed in the output from the <code>vxprint -t</code> command.

## Attaching and associating plexes

A plex becomes a participating plex for a volume by attaching it to a volume. (Attaching a plex associates it with the volume and enables the plex for use.) To attach a plex to an existing volume, use the following command:

```
# vxplex [-g diskgroup] att volume plex
```

For example, to attach a plex named `vol101-02` to a volume named `vol101` in the disk group, `mydg`, use the following command:

```
# vxplex -g mydg att vol101 vol101-02
```

If the volume does not already exist, a plex (or multiple plexes) can be associated with the volume when it is created using the following command:

```
# vxmake [-g diskgroup] -U usetype vol volume plex=plex1[,plex2...]
```

For example, to create a mirrored, `fsgen-type` volume named `home`, and to associate two existing plexes named `home-1` and `home-2` with `home`, use the following command:

```
# vxmake -g mydg -U fsgen vol home plex=home-1,home-2
```

You can also use the command `vxassist mirror volume` to add a data plex as a mirror to an existing volume.

## Taking plexes offline

Once a volume has been created and placed online (`ENABLED`), VxVM can temporarily disconnect plexes from the volume. This is useful, for example, when the hardware on which the plex resides needs repair or when a volume has been left unstartable and a source plex for the volume revive must be chosen manually.

Resolving a disk or system failure includes taking a volume offline and attaching and detaching its plexes. The two commands used to accomplish disk failure resolution are `vxmend` and `vxplex`.

To take a plex `OFFLINE` so that repair or maintenance can be performed on the physical disk containing subdisks of that plex, use the following command:

```
# vxmend [-g diskgroup] off plex
```

If a disk fails (for example, it has a head crash), use the `vxmend` command to take offline all plexes that have associated subdisks on the affected disk. For example, if plexes `vol101-02` and `vol102-02` in the disk group, `mydg`, had subdisks on a drive to be repaired, use the following command to take these plexes offline:

```
# vxmend -g mydg off vol101-02 vol102-02
```

This command places `vol101-02` and `vol102-02` in the `OFFLINE` state, and they remain in that state until it is changed. The plexes are not automatically recovered on rebooting the system.

## Detaching plexes

To temporarily detach one data plex in a mirrored volume, use the following command:

```
# vxplex [-g diskgroup] det plex
```

For example, to temporarily detach a plex named `vol101-02` in the disk group, `mydg`, and place it in maintenance mode, use the following command:

```
# vxplex -g mydg det vol101-02
```

This command temporarily detaches the plex, but maintains the association between the plex and its volume. However, the plex is not used for I/O. A plex detached with the preceding command is recovered at system reboot. The plex state is set to `STALE`, so that if a `vxvol start` command is run on the appropriate volume (for example, on system reboot), the contents of the plex is recovered and made `ACTIVE`.

When the plex is ready to return as an active part of its volume, it can be reattached to the volume.

See [“Reattaching plexes”](#) on page 296.

## Reattaching plexes

This section describes how to reattach plexes manually if automatic reattachment feature is disabled. This procedure may also be required for devices that are not automatically reattached. For example, VxVM does not automatically reattach plexes on site-consistent volumes.

When a disk has been repaired or replaced and is again ready for use, the plexes must be put back online (plex state set to `ACTIVE`). To set the plexes to `ACTIVE`, use one of the following procedures depending on the state of the volume.

- If the volume is currently `ENABLED`, use the following command to reattach the plex:

```
# vxplex [-g diskgroup] att volume plex ...
```

For example, for a plex named `vol101-02` on a volume named `vol101` in the disk group, `mydg`, use the following command:

```
# vxplex -g mydg att vol101 vol101-02
```



As when returning an `OFFLINE` plex to `ACTIVE`, this command starts to recover the contents of the plex and, after the recovery is complete, sets the plex utility state to `ACTIVE`.

- If the volume is not in use (not `ENABLED`), use the following command to re-enable the plex for use:

```
# vxmend [-g diskgroup] on plex
```

For example, to re-enable a plex named `vo101-02` in the disk group, `mydg`, enter:

```
# vxmend -g mydg on vo101-02
```

In this case, the state of `vo101-02` is set to `STALE`. When the volume is next started, the data on the plex is revived from another plex, and incorporated into the volume with its state set to `ACTIVE`.

If the `vxinfo` command shows that the volume is unstartable, set one of the plexes to `CLEAN` using the following command:

```
# vxmend [-g diskgroup] fix clean plex
```

Start the volume using the following command:

```
# vxvol [-g diskgroup] start volume
```

See the *Veritas Volume Manager Troubleshooting Guide*.

## Automatic plex reattachment

When a mirror plex encounters irrecoverable errors, Veritas Volume Manager (VxVM) detaches the plex from the mirrored volume. By default, VxVM automatically reattaches the affected mirror plexes when the underlying failed disk or LUN becomes visible. When VxVM detects that the device is online, the VxVM volume components on the involved LUN are automatically recovered, and the mirrors become usable.

VxVM uses the DMP failed LUN probing to detect when the device has come online. The timing for a reattach depends on the `dmp_restore_interval`, which is a tunable parameter. The number of LUNs that have reconnected may also affect the time required before the plex is reattached.

VxVM does not automatically reattach plexes on site-consistent volumes.

When VxVM is installed or the system reboots, VxVM starts the `vxattachd` daemon. The `vxattachd` daemon handles automatic reattachment for both plexes and sites. The `vxattachd` daemon also initiates the resynchronization process for a plex. After a plex is successfully reattached, `vxattachd` notifies `root`.

To disable automatic plex attachment, remove `vxattachd` from the start up scripts. Disabling `vxattachd` disables the automatic reattachment feature for both plexes and sites.

In a Cluster Volume Manager (CVM) the following considerations apply:

- If the global detach policy is set, a storage failure from any node causes all plexes on that storage to be detached globally. When the storage is connected back to any node, the `vxattachd` daemon triggers reattaching the plexes on the master node only.
- The automatic reattachment functionality is local to a node. When enabled on a node, all of the disk groups imported on the node are monitored. If the automatic reattachment functionality is disabled on a master node, the feature is disable on all shared disk groups and private disk groups imported on the master node.

See “[Automatic site reattachment](#)” on page 542.

## Moving plexes

Moving a plex copies the data content from the original plex onto a new plex. To move a plex, use the following command:

```
# vxplex [-g diskgroup] mv original_plex new_plex
```

For a move task to be successful, the following criteria must be met:

- The old plex must be an active part of an active (ENABLED) volume.
- The new plex must be at least the same size or larger than the old plex.
- The new plex must not be associated with another volume.

The size of the plex has several implications:

- If the new plex is smaller or more sparse than the original plex, an incomplete copy is made of the data on the original plex. If an incomplete copy is desired, use the `-o force` option to `vxplex`.
- If the new plex is longer or less sparse than the original plex, the data that exists on the original plex is copied onto the new plex. Any area that is not on the original plex, but is represented on the new plex, is filled from other complete plexes associated with the same volume.
- If the new plex is longer than the volume itself, then the remaining area of the new plex above the size of the volume is not initialized and remains unused.

## Copying volumes to plexes

This task copies the contents of a volume onto a specified plex. The volume to be copied must not be enabled. The plex cannot be associated with any other volume. To copy a plex, use the following command:

```
# vxplex [-g diskgroup] cp volume new_plex
```

After the copy task is complete, *new\_plex* is not associated with the specified volume *volume*. The plex contains a complete copy of the volume data. The plex that is being copied should be the same size or larger than the volume. If the plex being copied is larger than the volume, an incomplete copy of the data results. For the same reason, *new\_plex* should not be sparse.

## Dissociating and removing plexes

When a plex is no longer needed, you can dissociate it from its volume and remove it as an object from VxVM. You might want to remove a plex for the following reasons:

- to provide free disk space
- to reduce the number of mirrors in a volume so you can increase the length of another mirror and its associated volume. When the plexes and subdisks are removed, the resulting space can be added to other volumes
- to remove a temporary mirror that was created to back up a volume and is no longer needed
- to change the layout of a plex

To save the data on a plex to be removed, the configuration of that plex must be known. Parameters from that configuration (stripe unit size and subdisk ordering) are critical to the creation of a new plex to contain the same data. Before a plex is removed, you must record its configuration.

See “[Displaying plex information](#)” on page 289.”

To dissociate a plex from the associated volume and remove it as an object from VxVM, use the following command:

```
# vxplex [-g diskgroup] -o rm dis plex
```

For example, to dissociate and remove a plex named `vo101-02` in the disk group, `mydg`, use the following command:

```
# vxplex -g mydg -o rm dis vo101-02
```

This command removes the plex `vol01-02` and all associated subdisks.

Alternatively, you can first dissociate the plex and subdisks, and then remove them with the following commands:

```
# vxplex [-g diskgroup] dis plex
# vxedit [-g diskgroup] -r rm plex
```

When used together, these commands produce the same result as the `vxplex -o rm dis` command. The `-r` option to `vxedit rm` recursively removes all objects from the specified object downward. In this way, a plex and its associated subdisks can be removed by a single `vxedit` command.

## Changing plex attributes

---

**Warning:** To avoid possible data loss, change plex attributes with extreme care.

---

The `vxedit` command changes the attributes of plexes and other Volume Manager objects. To change plex attributes, use the following command:

```
# vxedit [-g diskgroup] set attribute=value ... plex
```

Plex fields that can be changed using the `vxedit` command include:

- `name`
- `putiln`
- `tutiln`
- `comment`

The `putiln` field attributes are maintained on reboot; `tutiln` fields are temporary and are not retained on reboot. VxVM sets the `putil0` and `tutil0` utility fields. Other Symantec products, such as Storage Foundation Manager (SFM), set the `putil1` and `tutil1` fields. The `putil2` and `tutil2` are available for you to use for site-specific purposes.

The following example command sets the `comment` field, and also sets `tutil2` to indicate that the subdisk is in use:

```
# vxedit -g mydg set comment="plex comment" tutil2="u" vol01-02
```

To prevent a particular plex from being associated with a volume, set the `putil0` field to a non-null string, as shown in the following command:

```
# vxedit -g mydg set putil0="DO-NOT-USE" vol01-02
```

See the `vxedit(1M)` manual page.



# Creating volumes

This chapter includes the following topics:

- [About volume creation](#)
- [Types of volume layouts](#)
- [Creating a volume](#)
- [Using vxassist](#)
- [Discovering the maximum size of a volume](#)
- [Disk group alignment constraints on volumes](#)
- [Creating a volume on any disk](#)
- [Creating a volume on specific disks](#)
- [Creating a mirrored volume](#)
- [Creating a volume with a version 0 DCO volume](#)
- [Creating a volume with a version 20 DCO volume](#)
- [Creating a volume with dirty region logging enabled](#)
- [Creating a striped volume](#)
- [Mirroring across targets, controllers or enclosures](#)
- [Mirroring across media types \(SSD and HDD\)](#)
- [Creating a RAID-5 volume](#)
- [Creating tagged volumes](#)
- [Creating a volume using vxmake](#)

- [Initializing and starting a volume](#)
- [Accessing a volume](#)

## About volume creation

Volumes are logical devices that appear as physical disk partition devices to data management systems. Volumes enhance recovery from hardware failure, data availability, performance, and storage configuration.

Volumes are created to take advantage of the VxVM concept of virtual disks. A file system can be placed on the volume to organize the disk space with files and directories. In addition, you can configure applications such as databases to organize data on volumes.

Disks and disk groups must be initialized and defined to VxVM before volumes can be created from them.

See [“About disk management”](#) on page 82.

See [“About disk groups”](#) on page 220.

## Types of volume layouts

VxVM allows you to create volumes with the following layout types:

**Concatenated**      A volume whose subdisks are arranged both sequentially and contiguously within a plex. Concatenation allows a volume to be created from multiple regions of one or more disks if there is not enough space for an entire volume on a single region of a disk. If a single LUN or disk is split into multiple subdisks, and each subdisk belongs to a unique volume, this is called carving.

See [“Concatenation, spanning, and carving”](#) on page 38.

**Striped**      A volume with data spread evenly across multiple disks. Stripes are equal-sized fragments that are allocated alternately and evenly to the subdisks of a single plex. There must be at least two subdisks in a striped plex, each of which must exist on a different disk. Throughput increases with the number of disks across which a plex is striped. Striping helps to balance I/O load in cases where high traffic areas exist on certain subdisks.

See [“Striping \(RAID-0\)”](#) on page 40.



Mirrored	<p>A volume with multiple data plexes that duplicate the information contained in a volume. Although a volume can have a single data plex, at least two are required for true mirroring to provide redundancy of data. For the redundancy to be useful, each of these data plexes should contain disk space from different disks.</p> <p>See <a href="#">“Mirroring (RAID-1)”</a> on page 43.</p>
RAID-5	<p>A volume that uses striping to spread data and parity evenly across multiple disks in an array. Each stripe contains a parity stripe unit and data stripe units. Parity can be used to reconstruct data if one of the disks fails. In comparison to the performance of striped volumes, write throughput of RAID-5 volumes decreases since parity information needs to be updated each time data is modified. However, in comparison to mirroring, the use of parity to implement data redundancy reduces the amount of space required.</p> <p>See <a href="#">“RAID-5 (striping with parity)”</a> on page 46.</p>
Mirrored-stripe	<p>A volume that is configured as a striped plex and another plex that mirrors the striped one. This requires at least two disks for striping and one or more other disks for mirroring (depending on whether the plex is simple or striped). The advantages of this layout are increased performance by spreading data across multiple disks and redundancy of data.</p> <p>See <a href="#">“Striping plus mirroring (mirrored-stripe or RAID-0+1)”</a> on page 44.</p>
Layered Volume	<p>A volume constructed from other volumes. Non-layered volumes are constructed by mapping their subdisks to VM disks. Layered volumes are constructed by mapping their subdisks to underlying volumes (known as storage volumes), and allow the creation of more complex forms of logical layout. Examples of layered volumes are striped-mirror and concatenated-mirror volumes.</p> <p>See <a href="#">Layered volumes</a>.</p> <p>A striped-mirror volume is created by configuring several mirrored volumes as the columns of a striped volume. This layout offers the same benefits as a non-layered mirrored-stripe volume. In addition it provides faster recovery as the failure of single disk does not force an entire striped plex offline.</p> <p>See <a href="#">Mirroring plus striping (striped-mirror, RAID-1+0 or RAID-10)</a>.</p> <p>A concatenated-mirror volume is created by concatenating several mirrored volumes. This provides faster recovery as the failure of a single disk does not force the entire mirror offline.</p>

## Supported volume logs and maps

Veritas Volume Manager supports the use of the following types of logs and maps with volumes:

- FastResync Maps are used to perform quick and efficient resynchronization of mirrors.

See [“FastResync”](#) on page 64.

These maps are supported either in memory (Non-Persistent FastResync), or on disk as part of a DCO volume (Persistent FastResync). Two types of DCO volume are supported:

- Version 0 DCO volumes only support Persistent FastResync for the traditional third-mirror break-off type of volume snapshot.

See [“Version 0 DCO volume layout”](#) on page 67.

See [“Creating a volume with a version 0 DCO volume”](#) on page 321.

- Version 20 DCO volumes, introduced in VxVM 4.0, support DRL logging (see below) and Persistent FastResync for full-sized and space-optimized instant volume snapshots.

See [“Version 20 DCO volume layout”](#) on page 67.

See [“Creating a volume with a version 20 DCO volume”](#) on page 324.

See [“Enabling FastResync on a volume”](#) on page 374.

- Dirty region logs allow the fast recovery of mirrored volumes after a system crash.

See [“Dirty region logging”](#) on page 59.

These logs are supported either as DRL log plexes, or as part of a version 20 DCO volume. Refer to the following sections for information on creating a volume on which DRL is enabled:

See [“Creating a volume with dirty region logging enabled”](#) on page 324.

See [“Creating a volume with a version 20 DCO volume”](#) on page 324.

- RAID-5 logs are used to prevent corruption of data during recovery of RAID-5 volumes.

See [“RAID-5 logging”](#) on page 51.

These logs are configured as plexes on disks other than those that are used for the columns of the RAID-5 volume.

See [“Creating a RAID-5 volume”](#) on page 329.

# Creating a volume

You can create volumes using an advanced approach or an assisted approach. Each method uses different tools. You may switch between the advanced and the assisted approaches at will.

---

**Note:** Most VxVM commands require superuser or equivalent privileges.

---

## Advanced approach

The advanced approach consists of a number of commands that typically require you to specify detailed input. These commands use a “building block” approach that requires you to have a detailed knowledge of the underlying structure and components to manually perform the commands necessary to accomplish a certain task. Advanced operations are performed using several different VxVM commands.

To create a volume using the advanced approach, perform the following steps in the order specified:

- Create subdisks using `vxmake sd`.  
See [“Creating subdisks”](#) on page 280.
- Create plexes using `vxmake plex`, and associate subdisks with them.  
See [“Creating plexes”](#) on page 289.  
See [“Associating subdisks with plexes”](#) on page 283.
- Associate plexes with the volume using `vxmake vol`.
- Initialize the volume using `vxvol start` or `vxvol init zero`.  
See [“Initializing and starting a volume created using vxmake”](#) on page 335.

The steps to create the subdisks and plexes, and to associate the plexes with the volumes can be combined by using a volume description file with the `vxmake` command.

See [“Creating a volume using a vxmake description file”](#) on page 333.

See [“Creating a volume using vxmake”](#) on page 331.

## Assisted approach

The assisted approach takes information about what you want to accomplish and then performs the necessary underlying tasks. This approach requires only minimal input from you, but also permits more detailed specifications.

Assisted operations are performed primarily through the `vxassist` command. `vxassist` and Storage Foundation Manager (SFM) create the required plexes and

subdisks using only the basic attributes of the desired volume as input. Additionally, they can modify existing volumes while automatically modifying any underlying or associated objects.

Both `vxassist` and SFM use default values for many volume attributes, unless you provide specific values. They do not require you to have a thorough understanding of low-level VxVM concepts, `vxassist` and SFM do not conflict with other VxVM commands or preclude their use. Objects created by `vxassist` and SFM are compatible and inter-operable with objects created by other VxVM commands and interfaces.

## Using `vxassist`

You can use the `vxassist` utility to create and modify volumes. Specify the basic requirements for volume creation or modification, and `vxassist` performs the necessary tasks.

The advantages of using `vxassist` rather than the advanced approach include:

- Most actions require that you enter only one command rather than several.
- You are required to specify only minimal information to `vxassist`. If necessary, you can specify additional parameters to modify or control its actions.
- Operations result in a set of configuration changes that either succeed or fail as a group, rather than individually. System crashes or other interruptions do not leave intermediate states that you have to clean up. If `vxassist` finds an error or an exceptional condition, it exits after leaving the system in the same state as it was prior to the attempted operation.

The `vxassist` utility helps you perform the following tasks:

- Creating volumes.
- Creating mirrors for existing volumes.
- Growing or shrinking existing volumes.
- Backing up volumes online.
- Reconfiguring a volume's layout online.

`vxassist` obtains most of the information it needs from sources other than your input. `vxassist` obtains information about the existing objects and their layouts from the objects themselves.

For tasks requiring new disk space, `vxassist` seeks out available disk space and allocates it in the configuration that conforms to the layout specifications and that offers the best use of free space.

The `vxassist` command takes this form:

```
# vxassist [options] keyword volume [attributes...]
```

where *keyword* selects the task to perform. The first argument after a `vxassist` keyword, *volume*, is a volume name, which is followed by a set of desired volume attributes. For example, the keyword `make` allows you to create a new volume:

```
# vxassist [options] make volume length [attributes]
```

The length of the volume can be specified in sectors, kilobytes, megabytes, or gigabytes by using a suffix character of *s*, *k*, *m*, or *g*. If no suffix is specified, the size is assumed to be in sectors.

See the `vxintro(1M)` manual page.

Additional attributes can be specified as appropriate, depending on the characteristics that you wish the volume to have. Examples are stripe unit width, number of columns in a RAID-5 or stripe volume, number of mirrors, number of logs, and log type.

By default, the `vxassist` command creates volumes in a default disk group according to a set of rules.

See “[Rules for determining the default disk group](#)” on page 222.

To use a different disk group, specify the `-g diskgroup` option to `vxassist`.

A large number of `vxassist` keywords and attributes are available for use.

See the `vxassist(1M)` manual page.

The simplest way to create a volume is to use default attributes.

### [Creating a volume on any disk](#)

More complex volumes can be created with specific attributes by controlling how `vxassist` uses the available storage space.

See “[Creating a volume on specific disks](#)” on page 313.

## Setting default values for vxassist

The default values that the `vxassist` command uses may be specified in the file `/etc/default/vxassist`. The defaults listed in this file take effect if you do not override them on the command line, or in an alternate defaults file that you specify using the `-d` option. A default value specified on the command line always takes precedence. `vxassist` also has a set of built-in defaults that it uses if it cannot find a value defined elsewhere.

You must create the `/etc/default` directory and the `vxassist` default file if these do not already exist on your system.

The format of entries in a defaults file is a list of attribute-value pairs separated by new lines. These attribute-value pairs are the same as those specified as options on the `vxassist` command line.

See the `vxassist(1M)` manual page.

To display the default attributes held in the file `/etc/default/vxassist`, use the following form of the `vxassist` command:

```
# vxassist help showattrs
```

The following is a sample `vxassist` defaults file:

```
# By default:
# create unmirrored, unstriped volumes
# allow allocations to span drives
# with RAID-5 create a log, with mirroring don't create a log
# align allocations on cylinder boundaries
    layout=nomirror,nostripe,span,nocontig,raid5log,noregionlog,
    diskalign

# use the fsgen usage type, except when creating RAID-5 volumes
    usetype=fsgen

# allow only root access to a volume
    mode=u=rw,g=,o=
    user=root
    group=root

# when mirroring, create two mirrors
    nmirror=2

# for regular striping, by default create between 2 and 8 stripe
# columns
    max_nstripe=8
    min_nstripe=2

# for RAID-5, by default create between 3 and 8 stripe columns
    max_nraid5stripe=8
    min_nraid5stripe=3

# by default, create 1 log copy for both mirroring and RAID-5 volumes
    nregionlog=1
    nraid5log=1
```

```
# by default, limit mirroring log lengths to 32Kbytes
  max_regionloglen=32k

# use 64K as the default stripe unit size for regular volumes
  stripe_stwid=64k

# use 16K as the default stripe unit size for RAID-5 volumes
  raid5_stwid=16k
```

## Using the SmartMove™ feature while attaching a plex

The SmartMove™ feature reduces the time and I/O required to attach or reattach a plex to an existing VxVM volume, in the specific case where a VxVM volume has a VxFS file system mounted on it. The SmartMove feature uses the VxFS information to detect free extents and avoid copying them.

To turn on the SmartMove feature, specify `usefssmartmove=all` in the file `/etc/default/vxsf`. This tunable is system-wide and persistent, so it only needs to be set once per server. The SmartMove feature is turned off by default.

The SmartMove feature takes effect when a plex is attached or reattached using the `vxplex`, `vxsd`, or `vxassist` commands.

---

**Note:** The file system must be mounted to get the benefits of the SmartMove™ feature.

---

When the SmartMove feature is on, less I/O is sent through the host, through the storage network and to the disks or LUNs. The SmartMove feature can be used for faster plex creation and faster array migrations.

The SmartMove feature enables migration from a traditional LUN to a thinly provisioned LUN, removing unused space in the process.

For more information, see the section on migrating to thin provisioning in the *Veritas Storage Foundation™ Advanced Features Administrator's Guide*.

## Discovering the maximum size of a volume

To find out how large a volume you can create within a disk group, use the following form of the `vxassist` command:

```
# vxassist [-g diskgroup] maxsize layout=layout [attributes]
```

For example, to discover the maximum size RAID-5 volume with 5 columns and 2 logs that you can create within the disk group, `dgrp`, enter the following command:

```
# vxassist -g dgrp maxsize layout=raid5 nlog=2
```

You can use storage attributes if you want to restrict the disks that `vxassist` uses when creating volumes.

See [“Creating a volume on specific disks”](#) on page 313.

The maximum size of a VxVM volume that you can create is 256TB.

## Disk group alignment constraints on volumes

Certain constraints apply to the length of volumes and to the numeric values of size attributes that apply to volumes. If a volume is created in a disk group that is compatible with the Cross-platform Data Sharing (CDS) feature, the volume’s length and the values of volume attributes that define the sizes of objects such as logs or stripe units, must be an integer multiple of the alignment value of 16 blocks (8 kilobytes). If the disk group is not compatible with the CDS feature, the volume’s length and attribute size values must be multiples of 1 block (512 bytes).

To discover the value in blocks of the alignment that is set on a disk group, use this command:

```
# vxprint -g diskgroup -G -F %align
```

By default, `vxassist` automatically rounds up the volume size and attribute size values to a multiple of the alignment value. (This is equivalent to specifying the attribute `dgalign_checking=round` as an additional argument to the `vxassist` command.)

If you specify the attribute `dgalign_checking=strict` to `vxassist`, the command fails with an error if you specify a volume length or attribute size value that is not a multiple of the alignment value for the disk group.

## Creating a volume on any disk

By default, the `vxassist make` command creates a concatenated volume that uses one or more sections of disk space. On a fragmented disk, this allows you to put together a volume larger than any individual section of free disk space available.

To change the default layout, edit the definition of the `layout` attribute defined in the `/etc/default/vxassist` file.



If there is not enough space on a single disk, `vxassist` creates a spanned volume. A spanned volume is a concatenated volume with sections of disk space spread across more than one disk. A spanned volume can be larger than any disk on a system, since it takes space from more than one disk.

To create a concatenated, default volume, use the following form of the `vxassist` command:

```
# vxassist [-b] [-g diskgroup] make volume length
```

Specify the `-b` option if you want to make the volume immediately available for use.

See [“Initializing and starting a volume”](#) on page 334.

For example, to create the concatenated volume `voldefault` with a length of 10 gigabytes in the default disk group:

```
# vxassist -b make voldefault 10g
```

## Creating a volume on specific disks

VxVM automatically selects the disks on which each volume resides, unless you specify otherwise. If you want a volume to be created on specific disks, you must designate those disks to VxVM. More than one disk can be specified.

To create a volume on a specific disk or disks, use the following command:

```
# vxassist [-b] [-g diskgroup] make volume length \  
  [layout=layout] diskname ...
```

Specify the `-b` option if you want to make the volume immediately available for use.

See [“Initializing and starting a volume”](#) on page 334.

For example, to create the volume `volspec` with length 5 gigabytes on disks `mydg03` and `mydg04`, use the following command:

```
# vxassist -b -g mydg make volspec 5g mydg03 mydg04
```

The `vxassist` command allows you to specify storage attributes. These give you control over the devices, including disks, controllers and targets, which `vxassist` uses to configure a volume. For example, you can specifically exclude disk `mydg05`.

---

**Note:** The `!` character is a special character in some shells. The following examples show how to escape it in a bash shell.

---

```
# vxassist -b -g mydg make volspec 5g \!mydg05
```

The following example excludes all disks that are on controller c2:

```
# vxassist -b -g mydg make volspec 5g \!ctlr:c2
```

This example includes only disks on controller c1 except for target t5:

```
# vxassist -b -g mydg make volspec 5g ctlr:c1 \!target:ctt5
```

If you want a volume to be created using only disks from a specific disk group, use the `-g` option to `vxassist`, for example:

```
# vxassist -g bigone -b make volmega 20g bigone10 bigone11
```

or alternatively, use the `diskgroup` attribute:

```
# vxassist -b make volmega 20g diskgroup=bigone bigone10 \  
    bigone11
```

Any storage attributes that you specify for use must belong to the disk group. Otherwise, `vxassist` will not use them to create a volume.

You can also use storage attributes to control how `vxassist` uses available storage, for example, when calculating the maximum size of a volume, when growing a volume or when removing mirrors or logs from a volume. The following example excludes disks `dgrp07` and `dgrp08` when calculating the maximum size of RAID-5 volume that `vxassist` can create using the disks in the disk group `dg`:

```
# vxassist -b -g dgrp maxsize layout=raid5 nlog=2 \!dgrp07 \!dgrp08
```

It is also possible to control how volumes are laid out on the specified storage.

See [“Specifying ordered allocation of storage to volumes”](#) on page 316.

If you are using VxVM in conjunction with Veritas SANPoint Control 2.0, you can specify how `vxassist` should use the available storage groups when creating volumes.

See [“Configuration of volumes on SAN storage”](#) on page 73.

See the `vxassist(1M)` manual page.

## Creating a volume on SSD devices

This section explains how to create a volume on Solid State Disk (SSD) device.

You must upgrade the disk group to version 150 for SSD support. To upgrade the disk group, use the following command:

```
# vxdg upgrade diskgroup
```

where *diskgroup* is the name of the disk group to which the disk belongs.

The allocation behavior of `vxassist` changes with presence of SSD devices in a disk group.

---

**Note:** If the disk group version is less than 150, `vxassist` will not honor media type of the device for making allocations.

---

The `vxassist` command allows you to specify Hard Disk Drive (HDD) or SSD devices for allocation using the `mediatype` attribute. For example, to create a volume `myvol` of size 1g on SSD disks in `mydg`, use the following command:

```
# vxassist -g mydg make myvol 1g mediatype:ssd
```

For example, to create a volume `myvol` of size 1g on HDD disks in `mydg`, use the following command:

```
# vxassist -g mydg make myvol 1g mediatype:hdd
```

If neither `mediatype:hdd` nor `mediatype:ssd` is specified, then `mediatype:hdd` is considered as default selection type which means only the HDD devices present in the disk group are considered for allocation.

If a mix of SSD devices and HDD devices are specified, the allocation is done only on HDD devices unless `mediatype:ssd` is explicitly specified. For example:

```
enclr1 : enclosure having all SSD devices
enclr2 : enclosure having all HDD devices
enclr3 : enclosure having mix of SSD and HDD devices
```

In the following command, volume `myvol` of size 1G is allocated on devices from `enclr2` array (only HDD devices):

```
# vxassist -g mydg make myvol 1G enclr:enclr1 enclr:enclr2
```

In order to create a volume on SSD devices from `enclr1` enclosure, following command should be used:

```
# vxassist -g mydg make myvol 1G enclr:enclr1 mediatype:ssd
```

If `enclr3` is only specified, only hdd devices present in `enclr3` are considered for allocation.

In the following two commands, volume `myvol` of size 1G is allocated on HDD devices from `enclr3` array:

```
# vxassist -g mydg make myvol 1G enclr:enclr3 mediatype:hdd
# vxassisst -g mydg make myvol 1G enclr:enclr3
```

In order to allocate a volume on SSD devices from enclr3 enclosure, following command should be used:

```
# vxassist -g mydg make myvol 1G enclr:enclr3 mediatype:ssd
```

The allocation fails, if the command is specified in one of the following two ways:

```
# vxassist -g mydg make myvol 1G enclr:enclr1 mediatype:hdd
```

In the above case, volume `myvol` cannot be created as there are no HDD devices in `enclr1` enclosure.

```
# vxassist -g mydg make myvol 1G enclr:enclr2 mediatype:ssd
```

In the above case, volume `myvol` cannot be created as there are no SSD devices in `enclr2` enclosure.

## Specifying ordered allocation of storage to volumes

Ordered allocation gives you complete control of space allocation. It requires that the number of disks that you specify to the `vxassist` command must match the number of disks that are required to create a volume. The order in which you specify the disks to `vxassist` is also significant.

If you specify the `-o ordered` option to `vxassist` when creating a volume, any storage that you also specify is allocated in the following order:

- Concatenate disks.
- Form columns.
- Form mirrors.

For example, the following command creates a mirrored-stripe volume with 3 columns and 2 mirrors on 6 disks in the disk group, `mydg`:

```
# vxassist -b -g mydg -o ordered make mirstrvol 10g \  
  layout=mirror-stripe ncol=3 mydg01 mydg02 mydg03 mydg04 mydg05 mydg06
```

This command places columns 1, 2 and 3 of the first mirror on disks `mydg01`, `mydg02` and `mydg03` respectively, and columns 1, 2 and 3 of the second mirror on disks `mydg04`, `mydg05` and `mydg06` respectively.

[Figure 7-1](#) shows an example of using ordered allocation to create a mirrored-stripe volume.

**Figure 7-1** Example of using ordered allocation to create a mirrored-stripe volume

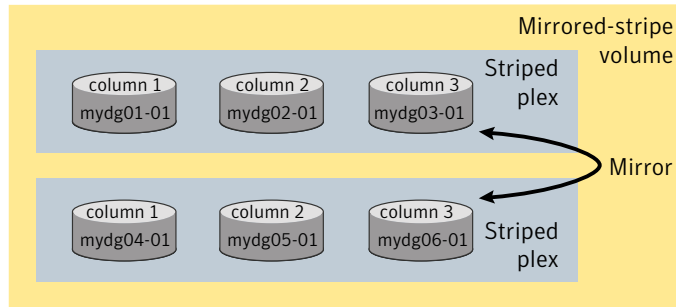

For layered volumes, `vxassist` applies the same rules to allocate storage as for non-layered volumes. For example, the following command creates a striped-mirror volume with 2 columns:

```
# vxassist -b -g mydg -o ordered make strmirvol 10g \
    layout=stripe-mirror ncol=2 mydg01 mydg02 mydg03 mydg04
```

This command mirrors column 1 across disks `mydg01` and `mydg03`, and column 2 across disks `mydg02` and `mydg04`.

[Figure 7-2](#) shows an example of using ordered allocation to create a striped-mirror volume.

**Figure 7-2** Example of using ordered allocation to create a striped-mirror volume

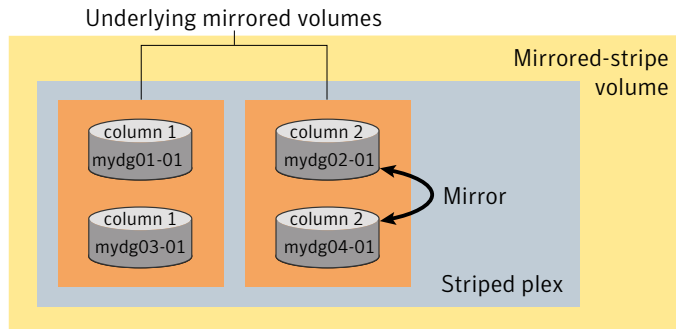

Additionally, you can use the `col_switch` attribute to specify how to concatenate space on the disks into columns. For example, the following command creates a mirrored-stripe volume with 2 columns:

```
# vxassist -b -g mydg -o ordered make strmir2vol 10g \  
  layout=mirror-stripe ncol=2 col_switch=3g,2g \  
  mydg01 mydg02 mydg03 mydg04 mydg05 mydg06 mydg07 mydg08
```

This command allocates 3 gigabytes from `mydg01` and 2 gigabytes from `mydg02` to column 1, and 3 gigabytes from `mydg03` and 2 gigabytes from `mydg04` to column 2. The mirrors of these columns are then similarly formed from disks `mydg05` through `mydg08`.

Figure 7-3 shows an example of using concatenated disk space to create a mirrored-stripe volume.

**Figure 7-3** Example of using concatenated disk space to create a mirrored-stripe volume

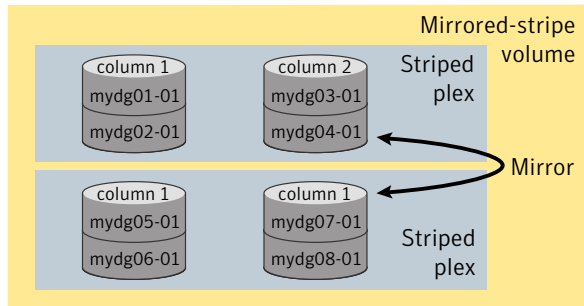

Other storage specification classes for controllers, enclosures, targets and trays can be used with ordered allocation. For example, the following command creates a 3-column mirrored-stripe volume between specified controllers:

```
# vxassist -b -g mydg -o ordered make mirstr2vol 80g \  
  layout=mirror-stripe ncol=3 \  
  ctrlr:c1 ctrlr:c2 ctrlr:c3 ctrlr:c4 ctrlr:c5 ctrlr:c6
```

This command allocates space for column 1 from disks on controllers `c1`, for column 2 from disks on controller `c2`, and so on.

Figure 7-4 shows an example of using storage allocation to create a mirrored-stripe volume across controllers.

**Figure 7-4** Example of storage allocation used to create a mirrored-stripe volume across controllers

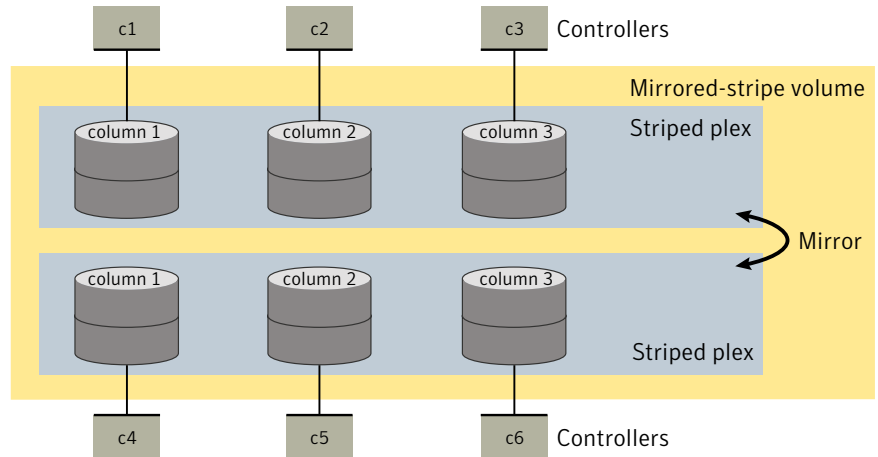

There are other ways in which you can control how `vxassist` lays out mirrored volumes across controllers.

See [“Mirroring across targets, controllers or enclosures”](#) on page 327.

## Creating a mirrored volume

A mirrored volume provides data redundancy by containing more than one copy of its data. Each copy (or mirror) is stored on different disks from the original copy of the volume and from other mirrors. Mirroring a volume ensures that its data is not lost if a disk in one of its component mirrors fails.

A mirrored volume requires space to be available on at least as many disks in the disk group as the number of mirrors in the volume.

If you specify `layout=mirror`, `vxassist` determines the best layout for the mirrored volume. Because the advantages of the layouts are related to the size of the volume, `vxassist` selects the layout based on the size of the volume. For smaller volumes, `vxassist` uses the simpler mirrored concatenated (`mirror-concat`) layout. For larger volumes, `vxassist` uses the more complex concatenated mirror (`concat-mirror`) layout. The attribute `stripe-mirror-col-split-trigger-pt` controls the selection. Volumes that are smaller than `stripe-mirror-col-split-trigger-pt` are created as `mirror-concat`, and volumes that are larger are created as `concat-mirror`. By default, the attribute `stripe-mirror-col-split-trigger-pt` is set to one gigabyte. The value can be set in `/etc/default/vxassist`. If there is a reason to implement

a particular layout, you can specify `layout=mirror-concat` or `layout=concat-mirror` to implement the desired layout.

To create a new mirrored volume, use the following command:

```
# vxassist [-b] [-g diskgroup] make volume length \  
    layout=mirror [nmirror=number] [init=active]
```

Specify the `-b` option if you want to make the volume immediately available for use.

See [“Initializing and starting a volume”](#) on page 334.

For example, to create the mirrored volume, `volmir`, in the disk group, `mydg`, use the following command:

```
# vxassist -b -g mydg make volmir 5g layout=mirror
```

To create a volume with 3 instead of the default of 2 mirrors, modify the command to read:

```
# vxassist -b -g mydg make volmir 5g layout=mirror nmirror=3
```

## Creating a mirrored-concatenated volume

A mirrored-concatenated volume mirrors several concatenated plexes. To create a concatenated-mirror volume, use the following command:

```
# vxassist [-b] [-g diskgroup] make volume length \  
    layout=mirror-concat [nmirror=number]
```

Specify the `-b` option if you want to make the volume immediately available for use.

See [“Initializing and starting a volume”](#) on page 334.

Alternatively, first create a concatenated volume, and then mirror it.

See [“Adding a mirror to a volume”](#) on page 355.

## Creating a concatenated-mirror volume

A concatenated-mirror volume is an example of a layered volume which concatenates several underlying mirror volumes. To create a concatenated-mirror volume, use the following command:

```
# vxassist [-b] [-g diskgroup] make volume length \  
    layout=concat-mirror [nmirror=number]
```



Specify the `-b` option if you want to make the volume immediately available for use.

See [“Initializing and starting a volume”](#) on page 334.

## Creating a volume with a version 0 DCO volume

If a data change object (DCO) and DCO volume are associated with a volume, this allows Persistent FastResync to be used with the volume.

See [“How persistent FastResync works with snapshots”](#) on page 68.

The version 0 data change object (DCO) and DCO volume layout was introduced in VxVM 3.2. The version 0 layout supports traditional (third-mirror) snapshots, but not full-sized instant snapshots, space-optimized instant snapshots nor DRL configured within the DCO volume.

See [“Determining the DCO version number”](#) on page 363.

See [“Version 0 DCO volume layout”](#) on page 67.

See [“Version 20 DCO volume layout”](#) on page 67.

See [“Creating a volume with a version 20 DCO volume”](#) on page 324.

To perform fast resynchronization of mirrors after a system crash or reboot, you must also enable dirty region logging (DRL) on a mirrored volume.

See [“Adding a version 0 DCO and DCO volume”](#) on page 440.

---

**Note:** You need a license to use the Persistent FastResync feature. If you do not have a license, you can configure a DCO object and DCO volume so that snap objects are associated with the original and snapshot volumes. However, without a license, only full resynchronization can be performed.

---

See [“How persistent FastResync works with snapshots”](#) on page 68.

**To create a volume with an attached version 0 DCO object and volume**

- 1 Ensure that the disk group has been upgraded to at least version 90. Use the following command to check the version of a disk group:

```
# vxdg list diskgroup
```

To upgrade a disk group to the latest version, use the following command:

```
# vxdg upgrade diskgroup
```

See [“Upgrading a disk group”](#) on page 270.

- 2 Use the following command to create the volume (you may need to specify additional attributes to create a volume with the desired characteristics):

```
# vxassist [-g diskgroup] make volume length layout=layout \  
  logtype=dco [ndcomirror=number] [dcolen=size] \  
  [fastresync=on] [other attributes]
```

For non-layered volumes, the default number of plexes in the mirrored DCO volume is equal to the lesser of the number of plexes in the data volume or 2. For layered volumes, the default number of DCO plexes is always 2. If required, use the `ndcomirror` attribute to specify a different number. It is recommended that you configure as many DCO plexes as there are data plexes in the volume. For example, specify `ndcomirror=3` when creating a 3-way mirrored volume.

The default size of each plex is 132 blocks unless you use the `dcolen` attribute to specify a different size. If specified, the size of the plex must be a multiple of 33 blocks from 33 up to a maximum of 2112 blocks.

By default, FastResync is not enabled on newly created volumes. Specify the `fastresync=on` attribute if you want to enable FastResync on the volume. If a DCO object and DCO volume are associated with the volume, Persistent FastResync is enabled; otherwise, Non-Persistent FastResync is enabled.

- 3 To enable DRL or sequential DRL logging on the newly created volume, use the following command:

```
# vxvol [-g diskgroup] set logtype=drl|drlseq volume
```

If you use ordered allocation when creating a mirrored volume on specified storage, you can use the optional `logdisk` attribute to specify on which disks dedicated log plexes should be created. Use the following form of the `vxassist` command to specify the disks from which space for the logs is to be allocated:

```
# vxassist [-g diskgroup] -o ordered make volume length \  
  layout=mirror logtype=log_type logdisk=disk[,disk,...] \  
  storage_attributes
```

If you do not specify the `logdisk` attribute, `vxassist` locates the logs in the data plexes of the volume.

See [Specifying ordered allocation of storage to volumes](#).

See the `vxassist(1M)` manual page.

See the `vxvol(1M)` manual page.

## Creating a volume with a version 20 DCO volume

To create a volume with an attached version 20 DCO object and volume

- 1 Ensure that the disk group has been upgraded to the latest version. Use the following command to check the version of a disk group:

```
# vxdg list diskgroup
```

To upgrade a disk group to the most recent version, use the following command:

```
# vxdg upgrade diskgroup
```

See [“Upgrading a disk group”](#) on page 270.

- 2 Use the following command to create the volume (you may need to specify additional attributes to create a volume with the desired characteristics):

```
# vxassist [-g diskgroup] make volume length layout=layout \  
logtype=dco dcoversion=20 [drl=on|sequential|off] \  
[ndcomirror=number] [fastresync=on] [other attributes]
```

Set the value of the `drl` attribute to `on` if dirty region logging (DRL) is to be used with the volume (this is the default setting). For a volume that will be written to sequentially, such as a database log volume, set the value to `sequential` to enable sequential DRL. The DRL logs are created in the DCO volume. The redundancy of the logs is determined by the number of mirrors that you specify using the `ndcomirror` attribute.

By default, Persistent FastResync is not enabled on newly created volumes. Specify the `fastresync=on` attribute if you want to enable Persistent FastResync on the volume.

See [“Determining the DCO version number”](#) on page 363.

See the `vxassist(1M)` manual page.

## Creating a volume with dirty region logging enabled

Dirty region logging (DRL), if enabled, speeds recovery of mirrored volumes after a system crash. To enable DRL on a volume that is created within a disk group with a version number between 20 and 100, specify the `logtype=drl` attribute to the `vxassist make` command as shown in this example usage:

```
# vxassist [-g diskgroup] make volume length layout=layout \  
logtype=drl [nlog=n] [loglen=size] [other attributes]
```

The `nlog` attribute can be used to specify the number of log plexes to add. By default, one log plex is added. The `loglen` attribute specifies the size of the log, where each bit represents one region in the volume. For example, the size of the log would need to be 20K for a 10GB volume with a region size of 64 kilobytes.

For example, to create a mirrored 10GB volume, `vol102`, with two log plexes in the disk group, `mydg`, use the following command:

```
# vxassist -g mydg make vol102 10g layout=mirror logtype=drl \  
    nlog=2 nmirror=2
```

Sequential DRL limits the number of dirty regions for volumes that are written to sequentially, such as database replay logs. To enable sequential DRL on a volume that is created within a disk group with a version number between 70 and 100, specify the `logtype=drlseq` attribute to the `vxassist make` command.

```
# vxassist [-g diskgroup] make volume length layout=layout \  
    logtype=drlseq [nlog=n] [other attributes]
```

It is also possible to enable the use of Persistent FastResync with this volume.

See [“Creating a volume with a version 0 DCO volume”](#) on page 321.

---

**Note:** Operations on traditional DRL log plexes are usually applicable to volumes that are created in disk groups with a version number of less than 110. If you enable DRL or sequential DRL on a volume that is created within a disk group with a version number of 110 or greater, the DRL logs are usually created within the plexes of a version 20 DCO volume.

---

See [“Creating a volume with a version 20 DCO volume”](#) on page 324.

## Creating a striped volume

A striped volume contains at least one plex that consists of two or more subdisks located on two or more physical disks. A striped volume requires space to be available on at least as many disks in the disk group as the number of columns in the volume.

See [“Striping \(RAID-0\)”](#) on page 40.

To create a striped volume, use the following command:

```
# vxassist [-b] [-g diskgroup] make volume length layout=stripe
```

Specify the `-b` option if you want to make the volume immediately available for use.

See [“Initializing and starting a volume”](#) on page 334.

For example, to create the 10-gigabyte striped volume `volzebra`, in the disk group, `mydg`, use the following command:

```
# vxassist -b -g mydg make volzebra 10g layout=stripe
```

This creates a striped volume with the default stripe unit size (64 kilobytes) and the default number of stripes (2).

You can specify the disks on which the volumes are to be created by including the disk names on the command line. For example, to create a 30-gigabyte striped volume on three specific disks, `mydg03`, `mydg04`, and `mydg05`, use the following command:

```
# vxassist -b -g mydg make stripevol 30g layout=stripe \  
  mydg03 mydg04 mydg05
```

To change the number of columns or the stripe width, use the `ncolumn` and `stripeunit` modifiers with `vxassist`. For example, the following command creates a striped volume with 5 columns and a 32-kilobyte stripe size:

```
# vxassist -b -g mydg make stripevol 30g layout=stripe \  
  stripeunit=32k ncol=5
```

## Creating a mirrored-stripe volume

A mirrored-stripe volume mirrors several striped data plexes. A mirrored-stripe volume requires space to be available on at least as many disks in the disk group as the number of mirrors multiplied by the number of columns in the volume.

To create a striped-mirror volume, use the following command:

```
# vxassist [-b] [-g diskgroup] make volume length \  
  layout=mirror-stripe [nmirror=number_of_mirrors] \  
  [ncol=number_of_columns] [stripewidth=size]
```

Specify the `-b` option if you want to make the volume immediately available for use.

See [“Initializing and starting a volume”](#) on page 334.

Alternatively, first create a striped volume, and then mirror it. In this case, the additional data plexes may be either striped or concatenated.

See [“Adding a mirror to a volume”](#) on page 355.

## Creating a striped-mirror volume

A striped-mirror volume is an example of a layered volume which stripes several underlying mirror volumes. A striped-mirror volume requires space to be available on at least as many disks in the disk group as the number of columns multiplied by the number of stripes in the volume.

To create a striped-mirror volume, use the following command:

```
# vxassist [-b] [-g diskgroup] make volume length \  
  layout=stripe-mirror [nmirror=number_of_mirrors] \  
  [ncol=number_of_columns] [stripewidth=size]
```

Specify the `-b` option if you want to make the volume immediately available for use.

See [“Initializing and starting a volume”](#) on page 334.

By default, VxVM attempts to create the underlying volumes by mirroring subdisks rather than columns if the size of each column is greater than the value for the attribute `stripe-mirror-col-split-trigger-pt` that is defined in the `vxassist` defaults file.

If there are multiple subdisks per column, you can choose to mirror each subdisk individually instead of each column. To mirror at the subdisk level, specify the layout as `stripe-mirror-sd` rather than `stripe-mirror`. To mirror at the column level, specify the layout as `stripe-mirror-col` rather than `stripe-mirror`.

## Mirroring across targets, controllers or enclosures

To create a volume whose mirrored data plexes lie on different controllers (also known as disk duplexing) or in different enclosures, use the `vxassist` command as described in this section.

In the following command, the attribute `mirror=target` specifies that volumes should be mirrored between targets on different controllers.

```
# vxassist [-b] [-g diskgroup] make volume length \  
  layout=layout mirror=target [attributes]
```

Specify the `-b` option if you want to make the volume immediately available for use.

See [“Initializing and starting a volume”](#) on page 334.

The attribute `mirror=ctlr` specifies that disks in one mirror should not be on the same controller as disks in other mirrors within the same volume:

```
# vxassist [-b] [-g diskgroup] make volume length \
  layout=layout mirror=ctrl [attributes]
```

---

**Note:** Both paths of an active/passive array are not considered to be on different controllers when mirroring across controllers.

---

The following command creates a mirrored volume with two data plexes in the disk group, `mydg`:

```
# vxassist -b -g mydg make volspec 10g layout=mirror nmirror=2 \
  mirror=ctrl ctrl:c2 ctrl:c3
```

The disks in one data plex are all attached to controller `c2`, and the disks in the other data plex are all attached to controller `c3`. This arrangement ensures continued availability of the volume should either controller fail.

The attribute `mirror=enclr` specifies that disks in one mirror should not be in the same enclosure as disks in other mirrors within the same volume.

The following command creates a mirrored volume with two data plexes:

```
# vxassist -b make -g mydg volspec 10g layout=mirror nmirror=2 \
  mirror=enclr enclr:enc1 enclr:enc2
```

The disks in one data plex are all taken from enclosure `enc1`, and the disks in the other data plex are all taken from enclosure `enc2`. This arrangement ensures continued availability of the volume should either enclosure become unavailable.

There are other ways in which you can control how volumes are laid out on the specified storage.

See [“Specifying ordered allocation of storage to volumes”](#) on page 316.

## Mirroring across media types (SSD and HDD)

This section describes how to mirror across media types (SSD and HDD).

To create a volume with a HDD plex and a SSD plex

- 1 Create a volume with media type HDD:

```
# vxassist -g mydg make myvol 1G mediatype:hdd
```

- 2 Add a mirror to the volume with media type SSD:

```
# vxassist -g mydg mirror myvol mediatype:ssd
```



---

**Note:** `mirror=mediatype` is not supported.

---

## Creating a RAID-5 volume

A RAID-5 volume requires space to be available on at least as many disks in the disk group as the number of columns in the volume. Additional disks may be required for any RAID-5 logs that are created.

---

**Note:** VxVM supports the creation of RAID-5 volumes in private disk groups, but not in shareable disk groups in a cluster environment.

---

You can create RAID-5 volumes by using either the `vxassist` command (recommended) or the `vxmake` command. Both approaches are described below.

A RAID-5 volume contains a RAID-5 data plex that consists of three or more subdisks located on three or more physical disks. Only one RAID-5 data plex can exist per volume. A RAID-5 volume can also contain one or more RAID-5 log plexes, which are used to log information about data and parity being written to the volume.

See [“RAID-5 \(striping with parity\)”](#) on page 46.

---

**Warning:** Do not create a RAID-5 volume with more than 8 columns because the volume will be unrecoverable in the event of the failure of more than one disk.

---

To create a RAID-5 volume, use the following command:

```
# vxassist [-b] [-g diskgroup] make volume length layout=raid5 \  
  [ncol=number_of_columns] [stripewidth=size] [nlog=number] \  
  [loglen=log_length]
```

Specify the `-b` option if you want to make the volume immediately available for use.

See [“Initializing and starting a volume”](#) on page 334.

For example, to create the RAID-5 volume `volraid` together with 2 RAID-5 logs in the disk group, `mydg`, use the following command:

```
# vxassist -b -g mydg make volraid 10g layout=raid5 nlog=2
```

This creates a RAID-5 volume with the default stripe unit size on the default number of disks. It also creates two RAID-5 logs rather than the default of one log.

If you require RAID-5 logs, you must use the `logdisk` attribute to specify the disks to be used for the log plexes.

RAID-5 logs can be concatenated or striped plexes, and each RAID-5 log associated with a RAID-5 volume has a complete copy of the logging information for the volume. To support concurrent access to the RAID-5 array, the log should be several times the stripe size of the RAID-5 plex.

It is suggested that you configure a minimum of two RAID-5 log plexes for each RAID-5 volume. These log plexes should be located on different disks. Having two RAID-5 log plexes for each RAID-5 volume protects against the loss of logging information due to the failure of a single disk.

If you use ordered allocation when creating a RAID-5 volume on specified storage, you must use the `logdisk` attribute to specify on which disks the RAID-5 log plexes should be created. Use the following form of the `vxassist` command to specify the disks from which space for the logs is to be allocated:

```
# vxassist [-b] [-g diskgroup] -o ordered make volume length \  
  layout=raid5 [ncol=number_columns] [nlog=number] \  
  [loglen=log_length] logdisk=disk[,disk,...] \  
  storage_attributes
```

For example, the following command creates a 3-column RAID-5 volume with the default stripe unit size on disks `mydg04`, `mydg05` and `mydg06`. It also creates two RAID-5 logs on disks `mydg07` and `mydg08`.

```
# vxassist -b -g mydg -o ordered make volraid 10g layout=raid5 \  
  ncol=3 nlog=2 logdisk=mydg07,mydg08 mydg04 mydg05 mydg06
```

The number of logs must equal the number of disks that is specified to `logdisk`.

See [“Specifying ordered allocation of storage to volumes”](#) on page 316.

See the `vxassist(1M)` manual page.

It is possible to add more logs to a RAID-5 volume at a later time.

See [“Adding a RAID-5 log”](#) on page 384.

## Creating tagged volumes

Volume tags are used to implement the Dynamic Storage Tiering (DST) feature of the Storage Foundation software.

See the *Veritas File System Administrator’s Guide*.

You can use the `tag` attribute with the `vxassist make` command to set a named tag and optional tag value on a volume, for example:

```
# vxassist -b -g mydg make volmir 5g layout=mirror tag=mirvol=5g
```

To list the tags that are associated with a volume, use this command:

```
# vxassist [-g diskgroup] listtag volume
```

If you do not specify a volume name, the tags of all volumes and vsets in the disk group are listed.

The following is an example of `listtag` output:

```
# vxassist -g dgl listtag vol
TY  NAME                DISKGROUP          TAG
=====
v   vol                 dgl                Symantec
```

To list the volumes that have a specified tag name, use this command:

```
# vxassist [-g diskgroup] list tag=tagname
```

Tag names and tag values are case-sensitive character strings of up to 256 characters. Tag names can consist of letters (A through Z and a through z), numbers (0 through 9), dashes (-), underscores (\_) or periods (.) from the ASCII character set. A tag name must start with either a letter or an underscore. Tag values can consist of any character from the ASCII character set with a decimal value from 32 through 127. If a tag value includes any spaces, use the `vxassist settag` command to set the tag on the newly created volume.

Dotted tag hierarchies are understood by the `list` operation. For example, the listing for `tag=a.b` includes all volumes that have tag names that start with `a.b`.

The tag names `site`, `udid` and `vdid` are reserved and should not be used. To avoid possible clashes with future product features, it is recommended that tag names do not start with any of the following strings: `as1`, `be`, `isp`, `nbu`, `sf`, `sync` or `vx`.

See [Setting tags on volumes](#).

## Creating a volume using vxmake

As an alternative to using `vxassist`, you can create a volume using the `vxmake` command to arrange existing subdisks into plexes, and then to form these plexes into a volume.

See [“Creating subdisks”](#) on page 280.

The example given in this section is to create a RAID-5 volume using `vxmake`.

Creating a RAID-5 plex for a RAID-5 volume is similar to creating striped plexes, except that the `layout` attribute is set to `raid5`. Subdisks can be implicitly associated in the same way as with striped plexes. For example, to create a four-column RAID-5 plex with a stripe unit size of 32 sectors, use the following command:

```
# vxmake -g mydg plex raidplex layout=raid5 stwidth=32 \  
sd=mydg00-01,mydg01-00,mydg02-00,mydg03-00
```

Note that because four subdisks are specified, but the number of columns is not specified, the `vxmake` command assumes a four-column RAID-5 plex and places one subdisk in each column. Striped plexes are created using the same method except that the `layout` is specified as `stripe`. If the subdisks are to be created and added later, use the following command to create the plex:

```
# vxmake -g mydg plex raidplex layout=raid5 ncolumn=4 stwidth=32
```

If no subdisks are specified, the `ncolumn` attribute must be specified. Subdisks can be added to the plex later using the `vxsd assoc` command.

See “[Associating subdisks with plexes](#)” on page 283.

If each column in a RAID-5 plex is to be created from multiple subdisks which may span several physical disks, you can specify to which column each subdisk should be added. For example, to create a three-column RAID-5 plex using six subdisks, use the following form of the `vxmake` command:

```
# vxmake -g mydg plex raidplex layout=raid5 stwidth=32 \  
sd=mydg00-00:0,mydg01-00:1,mydg02-00:2,mydg03-00:0, \  
mydg04-00:1,mydg05-00:2
```

This command stacks subdisks `mydg00-00` and `mydg03-00` consecutively in column 0, subdisks `mydg01-00` and `mydg04-00` consecutively in column 1, and subdisks `mydg02-00` and `mydg05-00` in column 2. Offsets can also be specified to create sparse RAID-5 plexes, as for striped plexes.

Log plexes may be created as default concatenated plexes by not specifying a `layout`, for example:

```
# vxmake -g mydg plex raidlog1 sd=mydg06-00  
# vxmake -g mydg plex raidlog2 sd=mydg07-00
```

The following command creates a RAID-5 volume, and associates the prepared RAID-5 plex and RAID-5 log plexes with it:

```
# vxmake -g mydg -Uraid5 vol raidvol \  
plex=raidplex,raidlog1,raidlog2
```

Each RAID-5 volume has one RAID-5 plex where the data and parity are stored. Any other plexes associated with the volume are used as RAID-5 log plexes to log information about data and parity being written to the volume.

After creating a volume using `vxmake`, you must initialize it before it can be used.

See [“Initializing and starting a volume”](#) on page 334.

## Creating a volume using a vxmake description file

You can use the `vxmake` command to add a new volume, plex or subdisk to the set of objects managed by VxVM. `vxmake` adds a record for each new object to the VxVM configuration database. You can create records either by specifying parameters to `vxmake` on the command line, or by using a file which contains plain-text descriptions of the objects. The file can also contain commands for performing a list of tasks. Use the following form of the command to have `vxmake` read the file from the standard input:

```
# vxmake [-g diskgroup] < description_file
```

Alternatively, you can specify the file to `vxmake` using the `-d` option:

```
# vxmake [-g diskgroup] -d description_file
```

The following sample description file defines a volume, `db`, with two plexes, `db-01` and `db-02`:

```
#rty #name          #options  
sd   mydg03-01     disk=mydg03 offset=0 len=10000  
sd   mydg03-02     disk=mydg03 offset=25000 len=10480  
sd   mydg04-01     disk=mydg04 offset=0 len=8000  
sd   mydg04-02     disk=mydg04 offset=15000 len=8000  
sd   mydg04-03     disk=mydg04 offset=30000 len=4480  
plex db-01         layout=STRIPE ncolumn=2 stwidth=16k  
                        sd=mydg03-01:0/0,mydg03-02:0/10000,mydg04-01:1/0,  
mydg04-02:1/8000,mydg04-03:1/16000  
sd   ramd1-01     disk=ramd1 len=640  
                        comment="Hot spot for dbvol"  
plex db-02         sd=ramd1-01:40320  
vol   db           usetype=gen plex=db-01,db-02  
                        readpol=prefer pfxname=db-02  
                        comment="Uses mem1 for hot spot in last 5m"
```

The subdisk definition for plex, `db-01`, must be specified on a single line. It is shown here split across two lines because of space constraints.

The first plex, `db-01`, is striped and has five subdisks on two physical disks, `mydg03` and `mydg04`. The second plex, `db-02`, is the preferred plex in the mirror, and has one subdisk, `ramd1-01`, on a volatile memory disk.

For detailed information about how to use `vxmake`, refer to the `vxmake(1M)` manual page.

After creating a volume using `vxmake`, you must initialize it before it can be used.

See [“Initializing and starting a volume created using vxmake”](#) on page 335.

## Initializing and starting a volume

If you create a volume using the `vxassist` command, `vxassist` initializes and starts the volume automatically unless you specify the attribute `init=none`.

When creating a volume, you can make it immediately available for use by specifying the `-b` option to the `vxassist` command, as shown here:

```
# vxassist -b [-g diskgroup] make volume length layout=mirror
```

The `-b` option makes VxVM carry out any required initialization as a background task. It also greatly speeds up the creation of striped volumes by initializing the columns in parallel.

As an alternative to the `-b` option, you can specify the `init=active` attribute to make a new volume immediately available for use. In this example, `init=active` is specified to prevent VxVM from synchronizing the empty data plaxes of a new mirrored volume:

```
# vxassist [-g diskgroup] make volume length layout=mirror \  
  init=active
```

---

**Warning:** There is a very small risk of errors occurring when the `init=active` attribute is used. Although written blocks are guaranteed to be consistent, read errors can arise in the unlikely event that `fsck` attempts to verify uninitialized space in the file system, or if a file remains uninitialized following a system crash. If in doubt, use the `-b` option to `vxassist` instead.

---

This command writes zeroes to the entire length of the volume and to any log plaxes. It then makes the volume active. You can also zero out a volume by specifying the attribute `init=zero` to `vxassist`, as shown in this example:

```
# vxassist [-g diskgroup] make volume length layout=raid5 \  
init=zero
```

You cannot use the `-b` option to make this operation a background task.

## Initializing and starting a volume created using vxmake

A volume may be initialized by running the `vxvol` command if the volume was created by the `vxmake` command and has not yet been initialized, or if the volume has been set to an uninitialized state.

To initialize and start a volume, use the following command:

```
# vxvol [-g diskgroup] start volume
```

The following command can be used to enable a volume without initializing it:

```
# vxvol [-g diskgroup] init enable volume
```

This allows you to restore data on the volume from a backup before using the following command to make the volume fully active:

```
# vxvol [-g diskgroup] init active volume
```

If you want to zero out the contents of an entire volume, use this command to initialize it:

```
# vxvol [-g diskgroup] init zero volume
```

## Accessing a volume

As soon as a volume has been created and initialized, it is available for use as a virtual disk partition by the operating system for the creation of a file system, or by application programs such as relational databases and other data management software.

Creating a volume in a disk group sets up block and character (raw) device files that can be used to access the volume:

```
/dev/vx/dsk/dg/vol    block device file for volume vol in disk group dg
```

```
/dev/vx/rdsk/dg/vol   character device file for volume vol in disk group dg
```

The pathnames include a directory named for the disk group. Use the appropriate device node to create, mount and repair file systems, and to lay out databases that require raw partitions.

As the `rootdg` disk group no longer has special significance, VxVM only creates volume device nodes for this disk group in the `/dev/vx/dsk/rootdg` and `/dev/vx/rdisk/rootdg` directories. VxVM does not create device nodes in the `/dev/vx/dsk` or `/dev/vx/rdisk` directories for the `rootdg` disk group.



# Administering volumes

This chapter includes the following topics:

- [About volume administration](#)
- [Displaying volume information](#)
- [Monitoring and controlling tasks](#)
- [Using Thin Provisioning](#)
- [Admin operations on an unmounted VxFS thin volume](#)
- [Using SmartMove with Thin Provisioning](#)
- [Stopping a volume](#)
- [Starting a volume](#)
- [Resizing a volume](#)
- [Adding a mirror to a volume](#)
- [Removing a mirror](#)
- [Adding logs and maps to volumes](#)
- [Preparing a volume for DRL and instant snapshots](#)
- [Adding traditional DRL logging to a mirrored volume](#)
- [Upgrading existing volumes to use version 20 DCOs](#)
- [Setting tags on volumes](#)
- [Changing the read policy for mirrored volumes](#)
- [Removing a volume](#)

- [Moving volumes from a VM disk](#)
- [Enabling FastResync on a volume](#)
- [Performing online relayout](#)
- [Monitoring Thin Reclamation using the vxtask command](#)
- [Converting between layered and non-layered volumes](#)
- [Adding a RAID-5 log](#)

## About volume administration

Veritas Volume Manager (VxVM) lets you perform common maintenance tasks on volumes. These include the following:

- [Displaying volume information](#)
- [Monitoring tasks](#)
- [Resizing volumes](#)
- [Adding and removing logs](#)
- [Adding and removing mirrors](#)
- [Removing volumes](#)
- [Changing the layout of volumes without taking them offline](#)

---

**Note:** To use most VxVM commands, you need superuser or equivalent privileges.

---

## Displaying volume information

You can use the `vxprint` command to display information about how a volume is configured.

To display the volume, plex, and subdisk record information for all volumes in the system, use the following command:

```
# vxprint -hvt
```

You can also apply the `vxprint` command to a single disk group:

```
# vxprint -g mydg -hvt
```

This example produces the following output:

V	NAME	RVG/VSET/CO	KSTATE	STATE	LENGTH	READPOL	PREFPLEX	UTYPE
PL	NAME	VOLUME	KSTATE	STATE	LENGTH	LAYOUT	NCOL/WID	MODE
SD	NAME	PLEX	DISK	DISKOFFS	LENGTH	[COL/]OFF	DEVICE	MODE
SV	NAME	PLEX	VOLNAME	NVOLLAYR	LENGTH	[COL/]OFF	AM/NM	MODE
SC	NAME	PLEX	CACHE	DISKOFFS	LENGTH	[COL/]OFF	DEVICE	MODE
DC	NAME	PARENTVOL	LOGVOL					
SP	NAME	SNAPVOL	DCO					
v	pubs	-	ENABLED	ACTIVE	22880	SELECT	-	fsgen
pl	pubs-01	pubs	ENABLED	ACTIVE	22880	CONCAT	-	RW
sd	mydg11-01	pubs-01	mydg11	0	22880	0	clt0d0	ENA
v	voldef	-	ENABLED	ACTIVE	20480	SELECT	-	fsgen
pl	voldef-01	voldef	ENABLED	ACTIVE	20480	CONCAT	-	RW
sd	mydg12-02	voldef-0	mydg12	0	20480	0	clt1d0	ENA

Here `v` is a volume, `pl` is a plex, and `sd` is a subdisk. The first few lines indicate the headers that match each type of output line that follows. Each volume is listed along with its associated plexes and subdisks.

You can ignore the headings for sub-volumes (`sv`), storage caches (`sc`), data change objects (`dc`) and snappoints (`sp`) in the sample output. No such objects are associated with the volumes that are shown.

To display volume-related information for a specific volume, use the following command:

```
# vxprint [-g diskgroup] -t volume
```

For example, to display information about the volume, `voldef`, in the disk group, `mydg`, use the following command:

```
# vxprint -g mydg -t voldef
```

This example produces the following output:

V	NAME	RVG/VSET/CO	KSTATE	STATE	LENGTH	READPOL	PREFPLEX	UTYPE
v	voldef	-	ENABLED	ACTIVE	20480	SELECT	-	fsgen

If you enable enclosure-based naming, `vxprint` shows enclosure-based names for the disk devices rather than OS-based names.

The output from the `vxprint` command includes information about the volume state.

See “[Volume states](#)” on page 340.

## Volume states

**Table 8-1** shows the volume states that may be displayed by VxVM commands such as `vxprint`.

**Table 8-1** Volume states

Volume state	Description
ACTIVE	<p>The volume has been started (the kernel state is currently ENABLED) or was in use (the kernel state was ENABLED) when the machine was rebooted.</p> <p>If the volume is ENABLED, the state of its plexes at any moment is not certain (because the volume is in use). If the volume is DISABLED, the plexes cannot be guaranteed to be consistent, but are made consistent when the volume is started.</p> <p>For a RAID-5 volume, if the volume is DISABLED, parity cannot be guaranteed to be synchronized.</p>
CLEAN	<p>The volume is not started (the kernel state is DISABLED) and its plexes are synchronized. For a RAID-5 volume, its plex stripes are consistent and its parity is good.</p>
EMPTY	<p>The volume contents are not initialized. When the volume is EMPTY, the kernel state is always DISABLED.</p>
INVALID	<p>The contents of an instant snapshot volume no longer represent a true point-in-time image of the original volume.</p>
NEEDSYNC	<p>You must resynchronize the volume the next time it is started. A RAID-5 volume requires a parity resynchronization.</p>
REPLAY	<p>The volume is in a transient state as part of a log replay. A log replay occurs when it becomes necessary to use logged parity and data. This state is only applied to RAID-5 volumes.</p>

**Table 8-1** Volume states (*continued*)

Volume state	Description
SYNC	<p>The volume is either in read-writeback recovery mode (the kernel state is ENABLED) or was in read-writeback mode when the machine was rebooted (the kernel state is DISABLED). With read-writeback recovery, plex consistency is recovered by reading data from blocks of one plex and writing the data to all other writable plexes. If the volume is ENABLED, the plexes are being resynchronized through the read-writeback recovery. If the volume is DISABLED, the plexes were being resynchronized through read-writeback when the machine rebooted and still need to be synchronized.</p> <p>For a RAID-5 volume, the volume is either undergoing a parity resynchronization (the kernel state is ENABLED) or was having its parity resynchronized when the machine was rebooted (the kernel state is DISABLED).</p>

The interpretation of these states during volume startup is modified by the persistent state log for the volume (for example, the DIRTY/CLEAN flag). If the clean flag is set, an ACTIVE volume was not written to by any processes or was not even open at the time of the reboot; therefore, it can be considered CLEAN. In any case, the clean flag is always set when the volume is marked CLEAN.

## Volume kernel states

The volume kernel state indicates the accessibility of the volume. The volume kernel state lets a volume have an offline (DISABLED), maintenance (DETACHED), or online (ENABLED) mode of operation.

You do not set these states; they are maintained internally. On a system that is operating properly, all volumes are ENABLED.

[Table 8-2](#) shows the volume kernel states that can be defined.

**Table 8-2** Volume kernel state

Volume kernel state	Description
DETACHED	Maintenance is being performed on the volume. The volume cannot be read from or written to, but certain plex operations and <code>ioctl</code> function calls are accepted.
DISABLED	The volume is offline and cannot be accessed.
ENABLED	The volume is online and can be read from or written to.

## Monitoring and controlling tasks

The VxVM task monitor tracks the progress of system recovery by monitoring task creation, maintenance, and completion. The task monitor lets you monitor task progress and modify characteristics of tasks, such as pausing and recovery rate (for example, to reduce the impact on system performance).

---

**Note:** VxVM supports this feature only for private disk groups, not for shared disk groups in a CVM environment.

---

### Specifying task tags

Every task is given a unique task identifier. This is a numeric identifier for the task that can be specified to the `vxtask` utility to specifically identify a single task. Several VxVM utilities also provide a `-t` option to specify an alphanumeric tag of up to 16 characters in length. This allows you to group several tasks by associating them with the same tag.

The following utilities accept the `-t` option:

- `vxassist`
- `vxevac`
- `vxmirror`
- `vxplex`
- `vxrecover`
- `vxrelayout`
- `vxresize`
- `vxsd`
- `vxvol`

For example, to execute a `vxrecover` command and track the resulting tasks as a group with the task tag `myrecovery`, use the following command:

```
# vxrecover -g mydg -t myrecovery -b mydg05
```

To track the resulting tasks, use the following command:

```
# vxtask monitor myrecovery
```

Any tasks started by the utilities invoked by `vxrecover` also inherit its task ID and task tag, establishing a parent-child task relationship.

For more information about the utilities that support task tagging, see their respective manual pages.

## Managing tasks with `vxtask`

You can use the `vxtask` command to administer operations on VxVM tasks. Operations include listing tasks, modifying the task state (pausing, resuming, aborting) and modifying the task's progress rate.

VxVM tasks represent long-term operations in progress on the system. Every task gives information on the time the operation started, the size and progress of the operation, and the state and rate of progress of the operation. You can change the state of a task, giving coarse-grained control over the progress of the operation. For those operations that support it, you can change the rate of progress of the task, giving more fine-grained control over the task.

New tasks take time to be set up, and so may not be immediately available for use after a command is invoked. Any script that operates on tasks may need to poll for the existence of a new task.

See the `vxtask(1M)` manual page.

### **vxtask operations**

The `vxtask` command supports the following operations:

<code>abort</code>	Stops the specified task. In most cases, the operations “back out” as if an I/O error occurred, reversing what has been done so far to the largest extent possible.
--------------------	---

<code>list</code>	<p>Displays a one-line summary for each task running on the system. The <code>-l</code> option prints tasks in long format. The <code>-h</code> option prints tasks hierarchically, with child tasks following the parent tasks. By default, all tasks running on the system are printed. If you include a <code>taskid</code> argument, the output is limited to those tasks whose <code>taskid</code> or task tag match <code>taskid</code>. The remaining arguments filter tasks and limit which ones are listed.</p> <p>In this release, the <code>vxtask list</code> command supports SmartMove and thin reclamation operation.</p> <ul style="list-style-type: none"> <li>■ If you use SmartMove to resync or sync the volume, plex, or subdisk, the <code>vxtask list</code> displays whether the operations is using SmartMove or not.</li> <li>■ In a LUN level reclamation, the <code>vxtask list</code> command provides information on the amount of the reclaim performed on each LUN.</li> <li>■ The <code>init=zero</code> on the thin volume may trigger the reclaim on the thin volume and the progress is seen in the <code>vxtask list</code> command.</li> </ul>
<code>monitor</code>	<p>Prints information continuously about a task or group of tasks as task information changes. This lets you track task progress. Specifying <code>-l</code> prints a long listing. By default, one-line listings are printed. In addition to printing task information when a task state changes, output is also generated when the task completes. When this occurs, the state of the task is printed as <code>EXITED</code>.</p>
<code>pause</code>	<p>Pauses a running task, causing it to suspend operation.</p>
<code>resume</code>	<p>Causes a paused task to continue operation.</p>
<code>set</code>	<p>Changes a task's modifiable parameters. Currently, there is only one modifiable parameter, <code>slow[=<i>iodelay</i>]</code> , which can be used to reduce the impact that copy operations have on system performance. If you specify <code>slow</code>, this introduces a delay between such operations with a default value for <code>iodelay</code> of 250 milliseconds. The larger <code>iodelay</code> value you specify, the slower the task progresses and the fewer system resources that it consumes in a given time. (The <code>vxplex</code>, <code>vxvol</code> and <code>vxrecover</code> commands also accept the <code>slow</code> attribute.)</p>

## Using the vxtask command

To list all tasks running on the system, use the following command:

```
# vxtask list
```



To print tasks hierarchically, with child tasks following the parent tasks, specify the `-h` option, as follows:

```
# vxtask -h list
```

To trace all paused tasks in the disk group `mydg`, as well as any tasks with the tag `sysstart`, use the following command:

```
# vxtask -g mydg -p -I sysstart list
```

To list all paused tasks, use the `vxtask -p list` command. To continue execution (the task may be specified by its ID or by its tag), use `vxtask resume`:

```
# vxtask -p list  
# vxtask resume 167
```

To monitor all tasks with the tag `myoperation`, use the following command:

```
# vxtask monitor myoperation
```

To cause all tasks tagged with `recoval1` to exit, use the following command:

```
# vxtask abort recoval1
```

This command causes VxVM to try to reverse the progress of the operation so far. For example, aborting an Online Relayout results in VxVM returning the volume to its original layout.

See [“Controlling the progress of a relayout”](#) on page 381.

## Using Thin Provisioning

This section describes how to use VxVM volumes with Thin Storage LUNs.

### About Thin Provisioning

Thin Provisioning is a storage array feature that optimizes storage use by automating storage provisioning. Administrators do not have to estimate how much storage an application requires. Instead, Thin Provisioning lets administrators provision large thin or thin reclaim capable LUNs to a host. Physical storage capacity is allocated from a thin pool to the thin/thin reclaim capable LUNs only after application I/O writes.

## About Thin Reclamation

When data deletion occurs, files are deleted, or database files are shrunk in size VxFS or CFS file system, space reclamation is not triggered automatically on thin or thin reclaimable storage. For example: A host that writes 200 GB of data on a file system that is supported by large thin or thin reclaim capable LUNs triggers allocation of at least 200 GB of physical disk space behind the large thin or thin reclaim capable LUNs. If the storage administrator deletes files or a DBA shrinks a database file of 200 GB of data from that same VxFS file system, the amount of physical storage behind the large thin or thin reclaim capable LUNs does not change. In such a case, there is at least 200 GB of physical disk space behind large thin or thin reclaim capable LUNs, now unused.

The Storage Foundation Thin Reclamation feature leverages Veritas File System (VxFS) knowledge of used and unused block ranges at the file system level. Thin Reclamation lets an administrator trigger online reclamation of unused Thin Storage in storage arrays that support Thin Reclamation. Thin Reclamation can be triggered on a file system, a set of disks (LUNs), a disk group, or a Storage enclosure. Thin Reclamation releases the reclaimed space to the free storage pool in the array and makes it available for use by other thin LUNs in the storage pool.

For a list of the storage arrays that support Thin Reclamation, see the Symantec Hardware Compatibility List (HCL):

<http://entsupport.symantec.com/docs/330441>

## Thin Reclamation of a disk, a disk group, or an enclosure

Use the `vxdisk reclaim` command to trigger online Thin Reclamation on one or more disks, disk groups, or enclosures. The following examples triggers reclamation on LUNs `disk1` and `disk2`, disk group `oradg`, and Enclosure=`EMC_Clariion0` respectively.

For disks:

```
# vxdisk reclaim disk1 disk2
```

For disk group:

```
# vxdisk reclaim oradg
```

For enclosure:

```
# vxdisk reclaim EMC_CLARiion0
```

You can only perform Thin Reclamation on LUNS which exhibit `thin_reclm` attribute/flag. VxVM automatically discovers LUNs that support Thin Reclamation

from capable storage arrays. To list devices that are known to be thin or thin\_reclm on a host, use the `vxdisk -o thin list` command. For example:

```
# vxdisk -o thin list
DEVICE          SIZE (mb)    PHYS_ALLOC (mb)  GROUP          TYPE
tagmastore-usp0_065a 10000        84               -              thinreclm
tagmastore-usp0_065b 10000        84               -              thinreclm
tagmastore-usp0_065c 10000        84               -              thinreclm
tagmastore-usp0_065d 10000        84               -              thinreclm
tagmastore-usp0_065e 10000        84               -              thinreclm
tagmastore-usp0_065f 10000        84               -              thinreclm
tagmastore-usp0_0652 10000        84               -              thinreclm
tagmastore-usp0_0653 10000        84               -              thinreclm
tagmastore-usp0_0654 10000        84               -              thinreclm
tagmastore-usp0_0655 10000        84               -              thinreclm
tagmastore-usp0_0656 10000        84               -              thinreclm
tagmastore-usp0_0657 10000        84               -              thinreclm
tagmastore-usp0_0658 10000        84               -              thinreclm
tagmastore-usp0_0659 10000        84               -              thinreclm
tagmastore-usp0_0660 10000        672              thindiskgroup  thinreclm
```

You can only perform Thin Reclamation if the VxVM volume is on a “mounted” VxFS file system.

For more information on how to trigger Thin Reclamation on a VxFS file system, see the *Veritas File System Administrator's Guide*.

Thin Reclamation takes considerable amount of time when you reclaim thin storage on a large number of LUNs or an enclosure or disk group.

See “[Monitoring Thin Reclamation using the vxtask command](#)” on page 382.

## Triggering space relamation

This section describes how to trigger space relamation.

**to trigger space reclamation**

- 1 Ensure you mounted the VxFS file system.

See the `mount(1M)` manual page.

If you need to mount the VxFS file system, see the `mount_vxfs(1M)` manual page.

- 2 Use the `fsadm` command to trigger space reclamation:

```
# /opt/VRTS/bin/fsadm -F vxfs -R /<VxFS_mount_point>
```

where `<VxFS_mount_point>` is the name of the VxFS file system mount point.

---

**Note:** If the VxFS file system is not mounted you will receive an error message. For example: Disk 3pardata0\_110 : Skipped. No VxFS file system found.

---

See the *Veritas File System Administrator's Guide* for more information on how to trigger Thin Reclamation on a VxFS file system.

## Admin operations on an unmounted VxFS thin volume

A thin volume is a volume composed of one or more thin LUNs. If a thin volume is not a mounted on a VxFS file system, any resynchronization, synchronization, or refresh operation on the volume, plex, or subdisk performs a full synchronization and allocates storage on the unused space of the volume. Only a mounted VxFS file system can use SmartMove to assist with optimized administrative operations on thin volumes.

By default, commands that mirror, take snapshots, or attach a plex may fail with an error message.

Some commands use the `-f` option and others use the `-o force` option to force the command. The command manual page contains details of the force option to be used.

---

**Note:** The full new plex or volume allocates physical storage on thin LUNs and will not be a thin/optimized operation.

---

# Using SmartMove with Thin Provisioning

This section describes how to use SmartMove with Thin Provisioning that improves the synchronization performance and uses thin storage efficiently.

## To use SmartMove with Thin Provisioning

- 1 Mount the volume as the VxFS file system type. For example:

```
# mount -F vxfs /dev/vx/dsk/oradg/oravol1 /oravol1
```

- 2 Run the following command:

```
# sync
```

- 3 Mirror the volume. For example:

```
# vxassist -g oradg add mirror oravol1
```

See the *Veritas Storage Foundation Advanced Features Administrator's Guide* for more information on Thin Provisioning and SmartMove.

## Stopping a volume

Stopping a volume renders it unavailable to the user, and changes the volume kernel state from ENABLED or DETACHED to DISABLED. If the volume cannot be disabled, it remains in its current state. To stop a volume, use the following command:

```
# vxvol [-g diskgroup] [-f] stop volume ...
```

To stop all volumes in a specified disk group, use the following command:

```
# vxvol [-g diskgroup] [-f] stopall
```

---

**Warning:** If you use the `-f` option to forcibly disable a volume that is currently open to an application, the volume remains open, but its contents are inaccessible. I/O operations on the volume fail, and this may cause data loss. You cannot deport a disk group until all its volumes are closed.

---

If you need to prevent a closed volume from being opened, use the `vxvol maint` command, as described in the following section.

## Putting a volume in maintenance mode

If all mirrors of a volume become `STALE`, you can place the volume in maintenance mode. Before you put the volume in maintenance mode, make sure the volume is stopped or it is in the `DISABLED` state. Then you can view the plexes while the volume is `DETACHED` and determine which plex to use for reviving the others. To place a volume in maintenance mode, use the following command:

```
# vxvol [-g diskgroup] maint volume
```

To assist in choosing the revival source plex, use `vxprint` to list the stopped volume and its plexes.

To take a plex offline, (in this example, `vol101-02` in the disk group, `mydg`), use the following command:

```
# vxmend -g mydg off vol101-02
```

Make sure that all the plexes are offline except for the one that you will use for revival. The plex from which you will revive the volume should be placed in the `STALE` state. The `vxmend on` command can change the state of an `OFFLINE` plex of a `DISABLED` volume to `STALE`. For example, to put the plex `vol1101-02` in the `STALE` state, use the following command:

```
# vxmend -g mydg on vol1101-02
```

Running the `vxvol start` command on the volume then revives the volume with the specified plex. Because you are starting the volume from a stale plex, you must specify the force option (`-f`).

By using the procedure above, you can enable the volume with each plex, and you can decide which plex to use to revive the volume.

After you specify a plex for revival, and you use the procedure above to enable the volume with the specified plex, put the volume back into the `DISABLED` state and put all the other plexes into the `STALE` state using the `vxmend on` command. Now, you can recover the volume.

See [“Starting a volume”](#) on page 350.

## Starting a volume

Starting a volume makes it available for use, and changes the volume state from `DISABLED` or `DETACHED` to `ENABLED`. To start a `DISABLED` or `DETACHED` volume, use the following command:

```
# vxvol [-g diskgroup] start volume ...
```

If you cannot enable a volume, it remains in its current state.

To start all DISABLED or DETACHED volumes in a disk group, enter the following:

```
# vxvol -g diskgroup startall
```

To start a DISABLED volume, enter the following:

```
# vxrecover -g diskgroup -s volume ...
```

To start all DISABLED volumes, enter the following:

```
# vxrecover -s
```

To prevent any recovery operations from being performed on the volumes, additionally specify the `-n` option to `vxrecover`.

## Resizing a volume

Resizing a volume changes its size. For example, if a volume is too small for the amount of data it needs to store, you can increase its length. To resize a volume, use one of the following commands: `vxresize` (preferred), `vxassist`, or `vxvol`. You can also use the graphical Veritas Enterprise Administrator (VEA) to resize volumes.

---

**Note:** You cannot use VxVM commands, Storage Foundation Manager (SFM), or VEA to resize a volume or any underlying file system on an encapsulated `root` disk. This is because the underlying disk partitions also need to be reconfigured. If you need to resize the volumes on the root disk, you must first unencapsulate the root disk.

---

If you increase a volume's size, the `vxassist` command automatically locates available disk space. The `vxresize` command lets you optionally specify the LUNs or disks to use to increase the size of a volume. The `vxvol` command requires that you have previously ensured that there is sufficient space available in the plexes of the volume to increase its size. The `vxassist` and `vxresize` commands free unused space for use by the disk group. For the `vxvol` command, you must do this yourself. To determine how much you can increase a volume, use the following command:

```
# vxassist [-g diskgroup] maxgrow volume
```

When you resize a volume, you can specify the length of a new volume in sectors, kilobytes, megabytes, or gigabytes. The unit of measure is added as a suffix to the

length (s, m, k, or g). If you do not specify a unit, sectors are assumed. The `vxassist` command also lets you specify an increment by which to change the volume's size.

---

**Warning:** If you use `vxassist` or `vxvol` to resize a volume, do not shrink it below the size of the file system on it. If you do not shrink the file system first, you risk unrecoverable data loss. If you have a `VxFS` file system, shrink the file system first, and then shrink the volume. For other file systems, you may need to back up your data so that you can later recreate the file system and restore its data.

---

## Resizing volumes with `vxresize`

Use the `vxresize` command to resize a volume containing a file system. Although you can use other commands to resize volumes containing file systems, `vxresize` offers the advantage of automatically resizing certain types of file system as well as the volume.

[Table 8-3](#) shows which operations are permitted, and whether you must unmount the file system before you resize the it.

**Table 8-3** Permitted resizing operations on file systems

	VxFS	UFS
Mounted file system	Grow and shrink	Grow only
Unmounted file system	Not allowed	Grow only

For example, the following command resizes a volume from 1 GB to 10 GB. The volume is `homevol` in the disk group `mydg`, and contains a `VxFS` file system. The command uses spare disks `mydg10` and `mydg11`.

```
# vxresize -g mydg -b -F vxfs -t homevolresize homevol 10g mydg10 mydg11
```

The `-b` option specifies that this operation runs in the background. To monitor its progress, specify the task tag `homevolresize` with the `vxtask` command.

When you use `vxresize`, note the following restrictions:

- `vxresize` works with `VxFS` and `UFS` file systems only.
- In some situations, when you resize large volumes, `vxresize` may take a long time to complete.



- If you resize a volume with a usage type other than FSGEN or RAID5, you can lose data. If such an operation is required, use the `-f` option to forcibly resize the volume.
- You cannot resize a volume that contains plexes with different layout types. Attempting to do so results in the following error message:

```
VxVM vxresize ERROR V-5-1-2536 Volume volume has different
organization in each mirror
```

To resize such a volume successfully, you must first reconfigure it so that each data plex has the same layout.

For more information about the `vxresize` command, see the `vxresize(1M)` manual page.

## Resizing volumes with `vxassist`

The following modifiers are used with the `vxassist` command to resize a volume:

<code>growto</code>	Increases the volume size to a specified length.
<code>growby</code>	Increases the volume size by a specified amount.
<code>shrinkto</code>	Reduces the volume size to a specified length.
<code>shrinkby</code>	Reduces the volume size by a specified amount.

---

**Warning:** You cannot grow or shrink any volume associated with an encapsulated root disk (`rootvol`, `usr`, `var`, `opt`, `swapvol`, and so on) because these map to a physical underlying partition on the disk and must be contiguous. If you try to grow `rootvol`, `usrvol`, `varvol`, or `swapvol`, the system could become unbootable if you need to revert back to booting from slices. It can also prevent a successful Solaris upgrade, and you might have to do a fresh install. The `upgrade_start` script might also fail.

---

### Extending to a given length

To extend a volume to a specific length, use the following command:

```
# vxassist [-b] [-g diskgroup] growto volume length
```

If you specify the `-b` option, growing the volume is a background task.

For example, to extend `volcat` to 2000 sectors, use the following command:

```
# vxassist -g mydg growto volcat 2000
```

If you want the subdisks to be grown using contiguous disk space, and you previously performed a relayout on the volume, also specify the attribute `layout=nodiskalign` to the `growto` command.

## Extending by a given length

To extend a volume by a specific length, use the following command:

```
# vxassist [-b] [-g diskgroup] growby volume length
```

If you specify `-b` option, growing the volume is a background task.

For example, to extend `volcat` by 100 sectors, use the following command:

```
# vxassist -g mydg growby volcat 100
```

If you want the subdisks to be grown using contiguous disk space, and you previously performed a relayout on the volume, also specify the attribute `layout=nodiskalign` to the `growby` command.

## Shrinking to a given length

To shrink a volume to a specific length, use the following command:

```
# vxassist [-g diskgroup] shrinkto volume length
```

For example, to shrink `volcat` to 1300 sectors, use the following command:

```
# vxassist -g mydg shrinkto volcat 1300
```

---

**Warning:** Do not shrink the volume below the current size of the file system or database using the volume. You can safely use the `vxassist shrinkto` command on empty volumes.

---

## Shrinking by a given length

To shrink a volume by a specific length, use the following command:

```
# vxassist [-g diskgroup] shrinkby volume length
```

For example, to shrink `volcat` by 300 sectors, use the following command:

```
# vxassist -g mydg shrinkby volcat 300
```

---

**Warning:** Do not shrink the volume below the current size of the file system or database using the volume. You can safely use the `vxassist shrinkby` command on empty volumes.

---

## Resizing volumes with vxvol

To change the length of a volume, use the following command:

```
# vxvol [-g diskgroup] set len=length volume
```

For example, to change the length of the volume `vol101`, in the disk group `mydg`, to 100000 sectors, use the following command:

```
# vxvol -g mydg set len=100000 vol101
```

---

**Note:** You cannot use the `vxvol set len` command to increase the size of a volume unless the needed space is available in the volume's plexes. When you reduce the volume's size using the `vxvol set len` command, the freed space is not released into the disk group's free space pool.

---

If a volume is active and you reduce its length, you must force the operation using the `-o force` option to `vxvol`. This precaution ensures that space is not removed accidentally from applications using the volume.

You can change the length of logs using the following command:

```
# vxvol [-g diskgroup] set loglen=length log_volume
```

---

**Warning:** Sparse log plexes are not valid. They must map the entire length of the log. If increasing the log length makes any of the logs invalid, the operation is not allowed. Also, if the volume is not active and is dirty (for example, if it has not been shut down cleanly), you cannot change the log length. If you are decreasing the log length, this feature avoids losing any of the log contents. If you are increasing the log length, it avoids introducing random data into the logs.

---

## Adding a mirror to a volume

You can add a mirror to a volume with the `vxassist` command, as follows:

```
# vxassist [-b] [-g diskgroup] mirror volume
```

Specifying the `-b` option makes synchronizing the new mirror a background task.

For example, to create a mirror of the volume `voltest` in the disk group, `mydg`, use the following command:

```
# vxassist -b -g mydg mirror voltest
```

You can also mirror a volume by creating a plex and then attaching it to a volume using the following commands:

```
# vxmake [-g diskgroup] plex plex sd=subdisk ...  
# vxplex [-g diskgroup] att volume plex
```

## Mirroring all volumes

To mirror all volumes in a disk group to available disk space, use the following command:

```
# /etc/vx/bin/vxmirror -g diskgroup -a
```

To configure VxVM to create mirrored volumes by default, use the following command:

```
# /etc/vx/bin/vxmirror -d yes
```

If you make this change, you can still make unmirrored volumes by specifying `nmirror=1` as an attribute to the `vxassist` command. For example, to create an unmirrored 20-gigabyte volume named `nomirror` in the disk group `mydg`, use the following command:

```
# vxassist -g mydg make nomirror 20g nmirror=1
```

## Mirroring volumes on a VM disk

Mirroring volumes creates one or more copies of your volumes on another disk. By creating mirror copies of your volumes, you protect your volumes against loss of data if a disk fails.

You can use this task on your root disk to make a second copy of the boot information available on an alternate disk. This lets you boot your system even if your root disk fails.

---

**Note:** This task only mirrors concatenated volumes. Volumes that are already mirrored or that contain subdisks that reside on multiple disks are ignored

---

**To mirror volumes on a disk**

- 1 Make sure that the target disk has an equal or greater amount of space as the source disk.
- 2 From the `vxdiskadm` main menu, select `Mirror volumes on a disk`.
- 3 At the prompt, enter the disk name of the disk that you wish to mirror:

```
Enter disk name [<disk>,list,q,?] mydg02
```

- 4 At the prompt, enter the target disk name (this disk must be the same size or larger than the originating disk):

```
Enter destination disk [<disk>,list,q,?] (default: any) mydg01
```

- 5 At the prompt, press **Return** to make the mirror:

```
Continue with operation? [y,n,q,?] (default: y)
```

The `vxdiskadm` program displays the status of the mirroring operation, as follows:

```
VxVM vxmirror INFO V-5-2-22 Mirror volume voltest-bk00
.
.
.
VxVM INFO V-5-2-674 Mirroring of disk mydg01 is complete.
```

- 6 At the prompt, indicate whether you want to mirror volumes on another disk (y) or return to the `vxdiskadm` main menu (n):

```
Mirror volumes on another disk? [y,n,q,?] (default: n)
```

## Additional mirroring considerations

The larger private region size that was introduced in VxVM 3.2 (1MB) and VxVM 5.0 (32MB) may create one of the following mirroring scenarios under which `vxdiskadm` fails:

- Mirroring a full root disk to a target disk that is the same size as the source disk. A full disk has no free cylinders.
- Mirroring a disk created using an earlier version of Veritas Volume Manager to a target disk that is the same size as the source disk. You only need to use this step if mirroring using `vxdiskadm` fails.

- Mirroring a full Veritas Volume Manager disk (not a root disk) that was encapsulated in VxVM 3.5 to a target disk that is the same size as the source disk. You only need to use this step if mirroring using `vxdiskadm` fails. See the `vxdiskadm(1M)` manual page.

**To create a mirror under any of these scenarios**

- 1 Determine the size of the source disk's private region, using one of the following methods:

- If the source disk is a root disk, obtain its private region length by running the following command:

```
# vxprint -l rootdisk
```

The disk media name of the root disk is typically `rootdisk`.

In the output, find the `privlen` value. In this example, the value is 3071:

```
devinfo: publen=39846240 privlen=3071
```

- If the source disk is not a root disk, obtain its private region length by running the following command:

```
# vxdisk list diskname
```

where *diskname* is the disk media name of the source disk.

In the displayed output, note the `len` value for the `private` field. In this example, the value of this field is 3071:

```
private: slice=4 offset=1 len=3071
```

- 2 Use the `vxdisksetup` program to initialize the target disk, Enter the following:

```
# /usr/lib/vxvm/bin/vxdisksetup -i c#t#d# privoffset=0 \  
privlen=XXXX publen=YYYY
```

where `XXXX` is the size of the source disk's private region, and `YYYY` is the size of its public region.

If your system is configured to use enclosure-based naming instead of OS-based naming, replace the `c#t#d#` name with the enclosure-based name for the disk.

- 3 Add the newly initialized target disk to the source disk group. Enter the following:

```
# vxdbg -g diskgroup adddisk medianame=c#t#d#
```

- 4 Use the `vxdiskadm` command and select `Mirror` volumes on a disk to create the mirror. Specify the disk media names of the source disk (*rootdisk*) and the target disk (*medianame*).

## Removing a mirror

When you no longer need a mirror, you can remove it to free disk space.

---

**Note:** VxVM will not allow you to remove the last valid plex associated with a volume.

---

To remove a mirror from a volume, use the following command:

```
# vxassist [-g diskgroup] remove mirror volume
```

You can also use storage attributes to specify the storage to be removed. For example, to remove a mirror on disk `mydg01` from volume `vol01`, enter the following.

---

**Note:** The `!` character is a special character in some shells. The following example shows how to escape it in a bash shell.

---

```
# vxassist -g mydg remove mirror vol01 \!mydg01
```

See [“Creating a volume on specific disks”](#) on page 313.

Alternatively, use the following command to dissociate and remove a mirror from a volume:

```
# vxplex [-g diskgroup] -o rm dis mirror
```

For example, to dissociate and remove a mirror named `vol01-02` from the disk group `mydg`, use the following command:

```
# vxplex -g mydg -o rm dis vol01-02
```

This command removes the mirror `vol01-02` and all associated subdisks. This is equivalent to entering the following commands separately:

```
# vxplex -g mydg dis vol01-02  
# vxedit -g mydg -r rm vol01-02
```

## Adding logs and maps to volumes

Veritas Volume Manager supports the following types of volume logs and maps:

- FastResync Maps improve performance and reduce I/O during mirror resynchronization. These maps can be either in memory (Non-Persistent) or on disk (Persistent) as part of a DCO volume.

See [“FastResync”](#) on page 64.

See [“Enabling FastResync on a volume”](#) on page 374.

Two types of DCO volumes are supported:

- Version 0 DCO volumes only support Persistent FastResync for the traditional third-mirror break-off type of volume snapshot.  
See [“Version 0 DCO volume layout”](#) on page 67.  
See [“Adding a version 0 DCO and DCO volume”](#) on page 440.
- Version 20 DCO volumes, introduced in VxVM 4.0, combine DRL logging (see below) and Persistent FastResync for full-sized and space-optimized instant volume snapshots.  
See [“Version 20 DCO volume layout”](#) on page 67.  
See [“Preparing a volume for DRL and instant snapshots”](#) on page 360.
- Dirty Region Logs let you quickly recover mirrored volumes after a system crash. These logs can be either DRL log plexes, or part of a version 20 DCO volume.  
See [“Dirty region logging”](#) on page 59.  
See [“Adding traditional DRL logging to a mirrored volume”](#) on page 366.  
See [“Preparing a volume for DRL and instant snapshots”](#) on page 360.
- RAID-5 logs prevent corruption of data during recovery of RAID-5 volumes. These logs are configured as plexes on disks other than those that are used for the columns of the RAID-5 volume.  
See [“RAID-5 logging”](#) on page 51.  
See [“Adding a RAID-5 log”](#) on page 384.

## Preparing a volume for DRL and instant snapshots

You can add a version 20 data change object (DCO) and DCO volume to an existing volume if the disk group version number is 110 or greater. You can also



simultaneously create a new volume, a DCO and DCO volume, and enable DRL as long as the disk group version is 110 or greater.

See [“Determining the DCO version number”](#) on page 363.

See [“Creating a volume with a version 20 DCO volume”](#) on page 324.

See [“Upgrading existing volumes to use version 20 DCOs”](#) on page 367.

---

**Note:** You need a license key to use the DRL and FastResync feature. If you do not have a license key, you can configure a DCO object and DCO volume so that snap objects are associated with the original and snapshot volumes. However, without a license key, only full resynchronization can be performed.

---

See [“How persistent FastResync works with snapshots”](#) on page 68.

To add a version 20 DCO and DCO volume to a volume, use the following command :

```
# vxsnap [-g diskgroup] prepare volume [ndcomirs=number] \  
  [regionsize=size] [drl=on|sequential|off] \  
  [storage_attribute ...]
```

The `ndcomirs` attribute specifies the number of DCO plexes that are created in the DCO volume. You should configure as many DCO plexes as there are data and snapshot plexes in the volume. The DCO plexes are used to set up a DCO volume for any snapshot volume that you subsequently create from the snapshot plexes. For example, specify `ndcomirs=5` for a volume with 3 data plexes and 2 snapshot plexes.

The value of the `regionsize` attribute specifies the size of the tracked regions in the volume. A write to a region is tracked by setting a bit in the change map. The default value is `64k` (64KB). A smaller value requires more disk space for the change maps, but the finer granularity provides faster resynchronization.

To enable DRL logging on the volume, specify `drl=on` (this is the default). For sequential DRL, specify `drl=sequential`. If you do not need DRL, specify `drl=off`.

You can also specify `vxassist`-style storage attributes to define the disks that can or cannot be used for the plexes of the DCO volume.

See [“Specifying storage for version 20 DCO plexes”](#) on page 362.

The `vxsnap prepare` command automatically enables Persistent FastResync on the volume. Persistent FastResync is also set automatically on any snapshots that are generated from a volume on which this feature is enabled.

If the volume is a RAID-5 volume, it is converted to a layered volume that can be used with instant snapshots and Persistent FastResync.

See [“Using a DCO and DCO volume with a RAID-5 volume”](#) on page 363.

By default, a version 20 DCO volume contains 32 per-volume maps. If you require more maps, you can use the `vxsnap addmap` command to add them.

See the `vxsnap(1M)` manual page.

## Specifying storage for version 20 DCO plexes

If you move the disks that contain volumes and their snapshots into different disk groups, you must ensure that the disks that contain their DCO plexes can accompany them. You can use storage attributes to specify which disks to use for the DCO plexes. (If you do not want to use dirty region logging (DRL) with a volume, you can specify the same disks as those on which the volume is configured, assuming that space is available on the disks). For example, to add a DCO object and mirrored DCO volume with plexes on `disk05` and `disk06` to the volume, `myvol`, use the following command:

```
# vxsnap -g mydg prepare myvol ndcomirs=2 alloc=disk05,disk06
```

To view the details of the DCO object and DCO volume that are associated with a volume, use the `vxprint` command. The following is example `vxprint -vh` output for the volume named `vol1` (the TUITLO and PUTILO columns are omitted for clarity):

TY	NAME	ASSOC	KSTATE	LENGTH	PLOFFS	STATE	...
v	vol1	fsgen	ENABLED	1024	-	ACTIVE	
pl	vol1-01	vol1	ENABLED	1024	-	ACTIVE	
sd	disk01-01	vol1-01	ENABLED	1024	0	-	
pl	foo-02	vol1	ENABLED	1024	-	ACTIVE	
sd	disk02-01	vol1-02	ENABLED	1024	0	-	
dc	vol1_dco	vol1	-	-	-	-	
v	vol1_dcl	gen	ENABLED	132	-	ACTIVE	
pl	vol1_dcl-01	vol1_dcl	ENABLED	132	-	ACTIVE	
sd	disk03-01	vol1_dcl-01	ENABLED	132	0	-	
pl	vol1_dcl-02	vol1_dcl	ENABLED	132	-	ACTIVE	
sd	disk04-01	vol1_dcl-02	ENABLED	132	0	-	

In this output, the DCO object is shown as `vol1_dco`, and the DCO volume as `vol1_dcl` with 2 plexes, `vol1_dcl-01` and `vol1_dcl-02`.

If you need to relocate DCO plexes to different disks, you can use the `vxassist move` command. For example, the following command moves the plexes of the

DCO volume, `vol1_dcl`, for volume `vol1` from `disk03` and `disk04` to `disk07` and `disk08`.

---

**Note:** The `!` character is a special character in some shells. The following example shows how to escape it in a bash shell.

---

```
# vxassist -g mydg move vol1_dcl \!disk03 \!disk04 disk07 disk08
```

See [“Moving DCO volumes between disk groups”](#) on page 261.

See the `vxassist(1M)` manual page.

See the `vxsnap(1M)` manual page.

## Using a DCO and DCO volume with a RAID-5 volume

You can add a DCO and DCO volume to a RAID-5 volume. This lets you use Persistent FastResync on the volume for fast resynchronization of snapshots on returning them to their original volume. However, this procedure has the side effect of converting the RAID-5 volume into a special type of layered volume. You can create space-optimized instant snapshots of such a volume, and you can add mirrors that may be broken off as full-sized instant snapshots. You cannot relayout or resize such a volume unless you convert it back to a pure RAID-5 volume.

To convert a volume back to a RAID-5 volume, remove any snapshot plexes from the volume, and dissociate the DCO and DCO volume from the layered volume. You can then perform relayout and resize operations on the resulting non-layered RAID-5 volume.

See [“Removing support for DRL and instant snapshots from a volume”](#) on page 365.

To allow Persistent FastResync to be used with the RAID-5 volume again, re-associate the DCO and DCO volume.

See [“Preparing a volume for DRL and instant snapshots”](#) on page 360.

---

**Warning:** Dissociating a DCO and DCO volume disables FastResync on the volume. A full resynchronization of any remaining snapshots is required when they are snapped back.

---

## Determining the DCO version number

To use the instant snapshot and DRL-enabled DCO features, you must use a version 20 DCO, rather than version 0 DCO.

### To find out the version number of a DCO that is associated with a volume

- 1 Use the `vxprint` command on the volume to discover the name of its DCO. Enter the following:

```
# DCONAME=`vxprint [-g diskgroup] -F%dco_name volume`
```

- 2 Use the `vxprint` command on the DCO to determine its version number. Enter the following:

```
# vxprint [-g diskgroup] -F%version $DCONAME
```

## Determining if DRL is enabled on a volume

### To determine if DRL (configured using a version 20 DCO) is enabled on a volume

- 1 Use the `vxprint` command on the volume to discover the name of its DCO. Enter the following:

```
# DCONAME=`vxprint [-g diskgroup] -F%dco_name volume`
```

- 2 To determine if DRL is enabled on the volume, enter the following command with the volume's DCO:

```
# vxprint [-g diskgroup] -F%dr1 $DCONAME
```

If this command displays `on`, DRL is enabled.

- 3 If DRL is enabled, enter the following command with the DCO to determine if sequential DRL is enabled:

```
# vxprint [-g diskgroup] -F%sequentialdr1 $DCONAME
```

If this command displays `on`, sequential DRL is enabled.

You can also use the following command with the volume:

```
# vxprint [-g diskgroup] -F%log_type volume
```

This displays the logging type as `REGION` for DRL, `DRLSEQ` for sequential DRL, or `NONE` if DRL is not enabled.

If the number of active mirrors in the volume is less than 2, DRL logging is not performed even if DRL is enabled on the volume.

See [“Determining if DRL logging is active on a volume”](#) on page 365.

## Determining if DRL logging is active on a volume

To determine if DRL logging (configured using a version 20 DCO) is active on a mirrored volume

- 1 Use the following `vxprint` commands to discover the name of the volume's DCO volume:

```
# DCONAME=`vxprint [-g diskgroup] -F%dc_name volume`  
# DCOVOL=`vxprint [-g diskgroup] -F%parent_vol $DCONAME`
```

- 2 Use the `vxprint` command on the DCO volume to find out if DRL logging is active:

```
# vxprint [-g diskgroup] -F%drlllogging $DCOVOL
```

This command returns `on` if DRL logging is enabled.

## Disabling and re-enabling DRL

To disable DRL (configured using a version 20 DCO) on a volume, enter the following:

```
# vxvol [-g diskgroup] set drl=off volume
```

To re-enable DRL on a volume, enter the following:

```
# vxvol [-g diskgroup] set drl=on volume
```

To re-enable sequential DRL on a volume, enter the following:

```
# vxvol [-g diskgroup] set drl=sequential volume
```

You can use these commands to change the DRL policy on a volume by first disabling and then re-enabling DRL as required. If a data change map (DCM, used with Veritas Volume Replicator) is attached to a volume, DRL is automatically disabled.

## Removing support for DRL and instant snapshots from a volume

To remove support for DRL and instant snapshot operation from a volume, use the following command to remove the DCO and DCO volume that are associated with the volume:

```
# vxsnap [-g diskgroup] unprepare volume
```

This command also has the effect of disabling FastResync tracking on the volume.

---

**Note:** If the volume is part of a snapshot hierarchy, this command fails .

---

## Adding traditional DRL logging to a mirrored volume

A traditional DRL log is configured within a DRL plex. A version 20 DCO volume cannot be used in conjunction with a DRL plex. The version 20 DCO volume layout includes space for a DRL log.

See [“Preparing a volume for DRL and instant snapshots”](#) on page 360.

To put dirty region logging (DRL) into effect for a mirrored volume, you must add a log subdisk to that volume. Only one log subdisk can exist per plex.

To add DRL logs to an existing volume, use the following command:

```
# vxassist [-b] [-g diskgroup] addlog volume logtype=drl \  
    [nlog=n] [loglen=size]
```

If specified, the `-b` option makes adding the new logs a background task.

The `nlog` attribute specifies the number of log plexes to add. By default, one log plex is added. The `loglen` attribute specifies the size of the log, where each bit represents one region in the volume. For example, a 10 GB volume with a 64 KB region size needs a 20K log.

For example, to add a single log plex for the volume `vol103` in the disk group `mydg`, use the following command:

```
# vxassist -g mydg addlog vol103 logtype=drl
```

When you use the `vxassist` command to add a log subdisk to a volume, a log plex is created by default to contain the log subdisk. If you do not want a log plex, include the keyword `nolog` in the layout specification.

For a volume that will be written to sequentially, such as a database log volume, use the following `logtype=drlseq` attribute to specify that sequential DRL will be used:

```
# vxassist -g mydg addlog volume logtype=drlseq [nlog=n]
```

After you create the plex containing a log subdisk, you can treat it as a regular plex. You can add subdisks to the log plex. If you need to, you can remove the log plex and log subdisk.

See [“Removing a traditional DRL log”](#) on page 367.

## Removing a traditional DRL log

You can use the `vxassist remove log` command to remove a traditional DRL log that is configured within a DRL plex. The command will not remove a DRL log that is configured within a version 20 DCO.

### To remove a traditional DRL log

- ◆ Type the following command:

```
# vxassist [-g diskgroup] remove log volume logtype=drl [nlog=n]
```

By default, the `vxassist` command removes one log. Use the optional attribute `nlog=n` to specify the number of logs that are to remain after the operation completes.

You can use storage attributes to specify the storage from which a log will be removed. For example, to remove a log on disk `mydg10` from volume `vol01`, enter the following command.

---

**Note:** The `!` character is a special character in some shells. The following example shows how to escape it in a bash shell.

---

```
# vxassist -g mydg remove log vol01 \!mydg10 logtype=drl
```

## Upgrading existing volumes to use version 20 DCOs

You can upgrade a volume created before VxVM 4.0 to take advantage of new features such as instant snapshots and DRL logs that are configured within the DCO volume. You must upgrade the version of the disk groups, remove snapshots and version 0 DCOs that are associated with volumes in the disk groups, and configure the volumes with version 20 DCOs.

---

**Note:** The plexes of the DCO volume require persistent storage space on disk to be available. To make room for the DCO plexes, you may need to add extra disks to the disk group, or reconfigure volumes to free up space in the disk group. You can also add disk space by using the disk group move feature to bring in spare disks from a different disk group.

---

See [“Reorganizing the contents of disk groups”](#) on page 256.

The `vxsnap prepare` command automatically enables FastResync on the volume and on any snapshots that are generated from it.

If the volume is a RAID-5 volume, it is converted to a layered volume that can be used with snapshots and FastResync.

### To upgrade an existing disk group and the volumes that it contains

- 1 Upgrade the disk group that contains the volume to the latest version before performing the remainder of the procedure described in this section. To check the version of a disk group, use the following command :

```
# vxdg list diskgroup
```

To upgrade a disk group to the latest version, use the following command:

```
# vxdg upgrade diskgroup
```

See [“Upgrading a disk group”](#) on page 270.

- 2 To discover which volumes in the disk group have version 0 DCOs associated with them, use the following command:

```
# vxprint [-g diskgroup] -F "%name" -e "v_hasdcolog"
```

This command assumes that the volumes can only have version 0 DCOs as the disk group has just been upgraded.

See [“Determining the DCO version number”](#) on page 363.

To upgrade each volume within the disk group, repeat the following steps as required.

- 3 If the volume to be upgraded has a traditional DRL plex or subdisk (that is, the DRL logs are not held in a version 20 DCO volume), use the following command to remove this:

```
# vxassist [-g diskgroup] remove log volume [nlog=n]
```

To specify the number, *n*, of logs to be removed, use the optional attribute *nlog=n*. By default, the `vxassist` command removes one log.

- 4 For a volume that has one or more associated snapshot volumes, use the following command to reattach and resynchronize each snapshot:

```
# vxassist [-g diskgroup] snapback snapvol
```

If FastResync was enabled on the volume before the snapshot was taken, the data in the snapshot plexes is quickly resynchronized from the original volume. If FastResync was not enabled, a full resynchronization is performed.

- 5 To turn off FastResync for the volume, use the following command :

```
# vxvol [-g diskgroup] set fastresync=off volume
```



- 6 To dissociate a version 0 DCO object, DCO volume and snap objects from the volume, use the following command:

```
# vxassist [-g diskgroup] remove log volume logtype=dc0
```

- 7 To upgrade the volume, use the following command:

```
# vxsnap [-g diskgroup] prepare volume [ndcomirs=number] \  
[regionsize=size] [drl=on|sequential|off] \  
[storage_attribute ...]
```

The `ndcomirs` attribute specifies the number of DCO plexes that are created in the DCO volume. You should configure as many DCO plexes as there are data and snapshot plexes in the volume. The DCO plexes are used to set up a DCO volume for any snapshot volume that you subsequently create from the snapshot plexes. For example, specify `ndcomirs=5` for a volume with 3 data plexes and 2 snapshot plexes.

The `regionsize` attribute specifies the size of the tracked regions in the volume. A write to a region is tracked by setting a bit in the change map. The default value is `64k` (64KB). A smaller value requires more disk space for the change maps, but the finer granularity provides faster resynchronization.

To enable DRL logging on the volume, specify `drl=on` (this is the default setting). If you need sequential DRL, specify `drl=sequential`. If you do not need DRL, specify `drl=off`.

To define the disks that can or cannot be used for the plexes of the DCO volume, you can also specify `vxassist`-style storage attributes.

## Setting tags on volumes

Volume tags implement Storage Foundation's Dynamic Storage Tiering feature. You can also apply tags to vsets using the same `vxvm` command syntax as shown below.

See the *Veritas File System Administrator's Guide*.

The following forms of the `vxassist` command let you do the following:

- Set a named tag and optional tag value on a volume.
- Replace a tag.
- Remove a tag from a volume.

```
# vxassist [-g diskgroup] settag volume|vset tagname[=tagvalue]
# vxassist [-g diskgroup] replacetag volume|vset oldtag newtag
# vxassist [-g diskgroup] removetag volume|vset tagname
```

To list the tags that are associated with a volume, use the following command:

```
# vxassist [-g diskgroup] listtag [volume|vset]
```

If you do not specify a volume name, all the volumes and vsets in the disk group are displayed. The acronym `vt` in the `TY` field indicates a vset.

The following is a sample `listtag` command:

```
# vxassist -g dg1 listtag vol
```

TY	NAME	DISKGROUP	TAG
v	vol	dg1	Oracle

To list the volumes that have a specified tag name, use the following command:

```
# vxassist [-g diskgroup] list tag=tagname volume
```

Tag names and tag values are case-sensitive character strings of up to 256 characters. Tag names can consist of the following ASCII characters:

- Letters (A through Z and a through z)
- Numbers (0 through 9)
- Dashes (-)
- Underscores (\_)
- Periods (.)

A tag name must start with either a letter or an underscore.

Tag values can consist of any ASCII character that has a decimal value from 32 through 127. If a tag value includes spaces, quote the specification to protect it from the shell, as follows:

```
# vxassist -g mydg settag myvol "dbvol=table space 1"
```

The `list` operation understands dotted tag hierarchies. For example, the listing for `tag=a.b` includes all volumes that have tag names starting with `a.b`.

The tag names `site`, `udid`, and `vdid` are reserved. Do not use them. To avoid possible clashes with future product features, do not start tag names with any of the following strings: `asl`, `be`, `nbu`, `sf`, `symc`, or `vx`.

## Changing the read policy for mirrored volumes

VxVM offers the choice of the following read policies on the data plexes in a mirrored volume:

<code>round</code>	Reads each plex in turn in “round-robin” fashion for each nonsequential I/O detected. Sequential access causes only one plex to be accessed. This approach takes advantage of the drive or controller read-ahead caching policies.
<code>prefer</code>	Reads first from a plex that has been named as the preferred plex.
<code>select</code>	Chooses a default policy based on plex associations to the volume. If the volume has an enabled striped plex, the <code>select</code> option defaults to preferring that plex; otherwise, it defaults to round-robin.  For disk group versions 150 or higher and if there is a SSD based plex available, it will be preferred over other plexes.
<code>siteread</code>	Reads preferentially from plexes at the locally defined site. This method is the default policy for volumes in disk groups where site consistency has been enabled.  For disk group versions 150 or higher and if the local site has a SSD based plex, it will be preferred.
<code>split</code>	Divides read the requests and distributes them across all the available plexes.

---

**Note:** You cannot set the read policy on a RAID-5 volume.

---

To set the read policy to `round`, use the following command:

```
# vxvol [-g diskgroup] rdpol round volume
```

For example, to set the read policy for the volume `vol101` in disk group `mydg` to round-robin, use the following command:

```
# vxvol -g mydg rdpol round vol101
```

To set the read policy to `prefer`, use the following command:

```
# vxvol [-g diskgroup] rdpol prefer volume preferred_plex
```

For example, to set the policy for `vol101` to read preferentially from the plex `vol101-02`, use the following command:

```
# vxvol -g mydg rdpol prefer vol101 vol101-02
```

To set the read policy to `select`, use the following command:

```
# vxvol [-g diskgroup] rdpol select volume
```

See “[Volume read policies](#)” on page 547.

## Removing a volume

If a volume is inactive or its contents have been archived, you may no longer need it. In that case, you can remove the volume and free up the disk space for other uses.

### To remove a volume

- 1 Remove all references to the volume by application programs, including shells, that are running on the system.
- 2 If the volume is mounted as a file system, unmount it with the following command:

```
# umount /dev/vx/dsk/diskgroup/volume
```

- 3 If the volume is listed in the `/etc/vfstab` file, edit this file and remove its entry. For more information about the format of this file and how you can modify it, see your operating system documentation
- 4 Stop all activity by VxVM on the volume with the following command:

```
# vxvol [-g diskgroup] stop volume
```

- 5 Remove the volume using the `vxassist` command as follows:

```
# vxassist [-g diskgroup] remove volume volume
```

You can also use the `vxedit` command to remove the volume as follows:

```
# vxedit [-g diskgroup] [-r] [-f] rm volume
```

The `-r` option to `vxedit` indicates recursive removal. This command removes all the plexes that are associated with the volume and all subdisks that are associated with the plexes. The `-f` option to `vxedit` forces removal. If the volume is still enabled, you must specify this option.

# Moving volumes from a VM disk

Before you disable or remove a disk, you can move the data from that disk to other disks on the system that have sufficient space.

## To move volumes from a disk

- 1 From the `vxdiskadm` main menu, select `Move volumes from a disk`.
- 2 At the following prompt, enter the disk name of the disk whose volumes you want to move, as follows:

```
Enter disk name [<disk>,list,q,?] mydg01
```

You can now optionally specify a list of disks to which the volume(s) should be moved. At the prompt, do one of the following:

- Press **Enter** to move the volumes onto available space in the disk group.
- Specify the disks in the disk group that should be used, as follows:

:

```
Enter disks [<disk ...>,list]
VxVM NOTICE V-5-2-283 Requested operation is to move all
volumes from disk mydg01 in group mydg.
```

NOTE: This operation can take a long time to complete.

```
Continue with operation? [y,n,q,?] (default: y)
```

As the volumes are moved from the disk, the `vxdiskadm` program displays the status of the operation:

```
VxVM vxevac INFO V-5-2-24 Move volume voltest ...
```

When the volumes have all been moved, the `vxdiskadm` program displays the following success message:

```
VxVM INFO V-5-2-188 Evacuation of disk mydg02 is complete.
```

- 3 At the following prompt, indicate whether you want to move volumes from another disk (y) or return to the `vxdiskadm` main menu (n):

```
Move volumes from another disk? [y,n,q,?] (default: n)
```

## Enabling FastResync on a volume

The recommended method for enabling FastResync on a volume with a version 20 DCO is to use the `vxsnap prepare` command.

See [“Preparing a volume for DRL and instant snapshots”](#) on page 360.

---

**Note:** To use this feature, you need a FastResync license.

---

FastResync quickly and efficiently resynchronizes stale mirrors. When you use FastResync with operations such as backup and decision support, it also increases the efficiency of the VxVM snapshot mechanism.

See [“About volume snapshots”](#) on page 387.

See [“FastResync”](#) on page 64.

You can enable the following versions of FastResync on a volume:

- Persistent FastResync holds copies of the FastResync maps on disk. If a system is rebooted, you can use these copies to quickly recover mirrored volumes. To use this form of FastResync, you must first associate a version 0 or a version 20 data change object (DCO) and DCO volume with the volume.  
See [“Adding a version 0 DCO and DCO volume”](#) on page 440.  
See [“Upgrading existing volumes to use version 20 DCOs”](#) on page 367.  
See [“Preparing a volume for DRL and instant snapshots”](#) on page 360.
- Non-Persistent FastResync holds the FastResync maps in memory. These maps do not survive on a system that is rebooted.

By default, FastResync is not enabled on newly-created volumes. If you want to enable FastResync on a volume that you create, specify the `fastresync=on` attribute to the `vxassist make` command.

---

**Note:** You cannot configure Persistent and Non-Persistent FastResync on a volume. If a DCO is associated with the volume, Persistent FastResync is used. Otherwise, Non-Persistent FastResync is used.

---

To turn on FastResync for an existing volume, specify `fastresync=on` to the `vxvol` command as follows:

```
# vxvol [-g diskgroup] set fastresync=on volume
```

To use FastResync with a snapshot, you must enable FastResync before the snapshot is taken, and it must remain enabled until after the snapback is completed.

## Checking whether FastResync is enabled on a volume

To check whether FastResync is enabled on a volume, use the following command:

```
# vxprint [-g diskgroup] -F%fastresync volume
```

If FastResync is enabled, the command returns `on`; otherwise, it returns `off`.

If FastResync is enabled, to check whether it is Non-Persistent or Persistent FastResync, use the following command:

```
# vxprint [-g diskgroup] -F%hasdcolog volume
```

If Persistent FastResync is enabled, the command returns `on`; otherwise, it returns `off`.

To list all volumes on which Non-Persistent FastResync is enabled, use the following command.

---

**Note:** The `!` character is a special character in some shells. The following example shows how to escape it in a bash shell.

---

```
# vxprint [-g diskgroup] -F "%name" \  
-e "v_fastresync=on && \!v_hasdcolog"
```

To list all volumes on which Persistent FastResync is enabled, use the following command:

```
# vxprint [-g diskgroup] -F "%name" -e "v_fastresync=on \  
&& v_hasdcolog"
```

## Disabling FastResync

Use the `vxvol` command to turn off Persistent or Non-Persistent FastResync for an existing volume, as follows:

```
# vxvol [-g diskgroup] set fastresync=off volume
```

Turning off FastResync releases all tracking maps for the specified volume. All subsequent reattaches do not use the FastResync facility, but perform a full resynchronization of the volume. The full resynchronization occurs even if you turn on FastResync later.

## Performing online relayout

You can use the `vxassist relayout` command to reconfigure the layout of a volume without taking it offline. The general form of this command is as follows:

```
# vxassist [-b] [-g diskgroup] relayout volume [layout=layout] \  
    [relayout_options]
```

If you specify the `-b` option, relayout of the volume is a background task.

The following destination layout configurations are supported.

<code>concat-mirror</code>	Concatenated-mirror
<code>concat</code>	Concatenated
<code>nomirror</code>	Concatenated
<code>nostripe</code>	Concatenated
<code>raid5</code>	RAID-5 (not supported for shared disk groups)
<code>span</code>	Concatenated
<code>stripe</code>	Striped

See [“Permitted relayout transformations”](#) on page 376.

For example, the following command changes the concatenated volume `vol102`, in disk group `mydg`, to a striped volume. By default, the striped volume has 2 columns and a 64 KB striped unit size.:

```
# vxassist -g mydg relayout vol102 layout=stripe
```

Sometimes, you may need to perform a relayout on a plex rather than on a volume.

See [“Specifying a plex for relayout”](#) on page 380.

## Permitted relayout transformations

[Table 8-4](#) shows the supported relayout transformations for concatenated volumes.

**Table 8-4** Supported relayout transformations for concatenated volumes

Relayout to	From concat
<code>concat</code>	No.
<code>concat-mirror</code>	No. Add a mirror, and then use <code>vxassist convert</code> instead.



**Table 8-4** Supported relayout transformations for concatenated volumes  
(continued)

Relayout to	From concat
mirror-concat	No. Add a mirror instead.
mirror-stripe	No. Use <code>vxassist convert</code> after relayout to the striped-mirror volume instead.
raid5	Yes. The stripe width and number of columns may be defined.
stripe	Yes. The stripe width and number of columns may be defined.
stripe-mirror	Yes. The stripe width and number of columns may be defined.

[Table 8-5](#) shows the supported relayout transformations for concatenated-mirror volumes.

**Table 8-5** Supported relayout transformations for concatenated-mirror volumes

Relayout to	From concat-mirror
concat	No. Use <code>vxassist convert</code> , and then remove the unwanted mirrors from the resulting mirrored-concatenated volume instead.
concat-mirror	No.
mirror-concat	No. Use <code>vxassist convert</code> instead.
mirror-stripe	No. Use <code>vxassist convert</code> after relayout to the striped-mirror volume instead.
raid5	Yes.
stripe	Yes. This relayout removes a mirror and adds striping. The stripe width and number of columns may be defined.
stripe-mirror	Yes. The stripe width and number of columns may be defined.

[Table 8-6](#) shows the supported relayout transformations for RAID-5 volumes.

**Table 8-6** Supported relayout transformations for mirrored-stripe volumes

Relayout to	From mirror-stripe
concat	Yes.
concat-mirror	Yes.

**Table 8-6** Supported layout transformations for mirrored-stripe volumes  
*(continued)*

Relayout to	From mirror-stripe
mirror-concat	No. Use <code>vxassist convert</code> after relayout to the concatenated-mirror volume instead.
mirror-stripe	No. Use <code>vxassist convert</code> after relayout to the striped-mirror volume instead.
raid5	Yes. The stripe width and number of columns may be changed.
stripe	Yes. The stripe width or number of columns must be changed.
stripe-mirror	Yes. The stripe width or number of columns must be changed. Otherwise, use <code>vxassist convert</code> .

[Table 8-7](#) shows the supported layout transformations for mirror-concatenated volumes.

**Table 8-7** Supported layout transformations for mirrored-concatenated volumes

Relayout to	From mirror-concat
concat	No. Remove the unwanted mirrors instead.
concat-mirror	No. Use <code>vxassist convert</code> instead.
mirror-concat	No.
mirror-stripe	No. Use <code>vxassist convert</code> after relayout to the striped-mirror volume instead.
raid5	Yes. The stripe width and number of columns may be defined. Choose a plex in the existing mirrored volume on which to perform the relayout. The other plexes are removed at the end of the relayout operation.
stripe	Yes.
stripe-mirror	Yes.

[Table 8-8](#) shows the supported layout transformations for mirrored-stripe volumes.

**Table 8-8** Supported relayout transformations for mirrored-stripe volumes

Relayout to	From mirror-stripe
concat	Yes.
concat-mirror	Yes.
mirror-concat	No. Use <code>vxassist convert</code> after relayout to the concatenated-mirror volume instead.
mirror-stripe	No. Use <code>vxassist convert</code> after relayout to the striped-mirror volume instead.
raid5	Yes. The stripe width and number of columns may be changed.
stripe	Yes. The stripe width or number of columns must be changed.
stripe-mirror	Yes. The stripe width or number of columns must be changed. Otherwise, use <code>vxassist convert</code> .

[Table 8-9](#) shows the supported relayout transformations for unmirrored stripe and layered striped-mirror volumes.

**Table 8-9** Supported relayout transformations for unmirrored stripe and layered striped-mirror volumes

Relayout to	From stripe or stripe-mirror
concat	Yes.
concat-mirror	Yes.
mirror-concat	No. Use <code>vxassist convert</code> after relayout to the concatenated-mirror volume instead.
mirror-stripe	No. Use <code>vxassist convert</code> after relayout to the striped-mirror volume instead.
raid5	Yes. The stripe width and number of columns may be changed.
stripe	Yes. The stripe width or number of columns must be changed.
stripe-mirror	Yes. The stripe width or number of columns must be changed.

## Specifying a non-default layout

You can specify one or more of the following relayout options to change the default layout configuration:

<code>ncol=number</code>	Specifies the number of columns.
<code>ncol+=number</code>	Specifies the number of columns to add.
<code>ncol=-number</code>	Specifies the number of columns to remove.
<code>stripeunit=size</code>	Specifies the stripe width.

The following examples use `vxassist` to change the stripe width and number of columns for a striped volume in the disk group `dbasedg`:

```
# vxassist -g dbasedg relayout vol03 stripeunit=64k ncol=6
# vxassist -g dbasedg relayout vol03 ncol+=2
# vxassist -g dbasedg relayout vol03 stripeunit=128k
```

The following example changes a concatenated volume to a RAID-5 volume with four columns:

```
# vxassist -g dbasedg relayout vol04 layout=raid5 ncol=4
```

## Specifying a plex for relayout

If you have enough disks and space in the disk group, you can change any layout to RAID-5. To convert a mirrored volume to RAID-5, you must specify which plex is to be converted. When the conversion finishes, all other plexes are removed, releasing their space for other purposes. If you convert a mirrored volume to a layout other than RAID-5, the unconverted plexes are not removed. Specify the plex to be converted by naming it in place of a volume as follows:

```
# vxassist [-g diskgroup] relayout plex [layout=layout] \
  [relayout_options]
```

## Tagging a relayout operation

To control the progress of a relayout operation, for example to pause or reverse it, use the `-t` option to `vxassist` to specify a task tag for the operation. For example, the following relayout is performed as a background task and has the tag `myconv`:

```
# vxassist -b -g dbasedg -t myconv relayout vol04 layout=raid5 \
  ncol=4
```

See [“Viewing the status of a relayout”](#) on page 381.

See [“Controlling the progress of a relayout”](#) on page 381.

## Viewing the status of a relayout

Online relayout operations take time to perform. You can use the `vxrelayout` command to obtain information about the status of a relayout operation. For example, the following command:

```
# vxrelayout -g mydg status vol04
```

might display output similar to the following:

```
STRIPED, columns=5, stwidth=128--> STRIPED, columns=6,  
stwidth=128  
Relayout running, 68.58% completed.
```

In this example, the reconfiguration is in progress for a striped volume from 5 to 6 columns, and is over two-thirds complete.

See the `vxrelayout(1M)` manual page.

If you specify a task tag to `vxassist` when you start the relayout, you can use this tag with the `vxtask` command to monitor the progress of the relayout. For example, to monitor the task that is tagged as `myconv`, enter the following:

```
# vxtask monitor myconv
```

## Controlling the progress of a relayout

You can use the `vxtask` command to stop (pause) the relayout temporarily, or to cancel it (abort). If you specify a task tag to `vxassist` when you start the relayout, you can use this tag to specify the task to `vxtask`. For example, to pause the relayout operation that is tagged as `myconv`, enter:

```
# vxtask pause myconv
```

To resume the operation, use the `vxtask` command as follows:

```
# vxtask resume myconv
```

For relayout operations that have not been stopped using the `vxtask pause` command (for example, the `vxtask abort` command was used to stop the task, the transformation process died, or there was an I/O failure), resume the relayout by specifying the `start` keyword to `vxrelayout`, as follows:

```
# vxrelayout -g mydg -o bg start vol04
```

If you use the `vxrelayout start` command to restart a relayout that you previously suspended using the `vxtask pause` command, a new untagged task is created to

complete the operation. You cannot then use the original task tag to control the relayout.

The `-o bg` option restarts the relayout in the background. You can also specify the `slow` and `iosize` option modifiers to control the speed of the relayout and the size of each region that is copied. For example, the following command inserts a delay of 1000 milliseconds (1 second) between copying each 10 MB region:

```
# vxrelayout -g mydg -o bg,slow=1000,iosize=10m start vol04
```

The default delay and region size values are 250 milliseconds and 1 MB respectively.

To reverse the direction of relayout operation that is stopped, specify the `reverse` keyword to `vxrelayout` as follows:

```
# vxrelayout -g mydg -o bg reverse vol04
```

This undoes changes made to the volume so far, and returns it to its original layout.

If you cancel a relayout using `vxtask abort`, the direction of the conversion is also reversed, and the volume is returned to its original configuration.

See [“Managing tasks with vxtask”](#) on page 343.

See the `vxrelayout(1M)` manual page.

See the `vxtask(1M)` manual page.

## Monitoring Thin Reclamation using the `vxtask` command

This section describes how to monitor thin reclamation using the `vxtask` command.

**To monitor thin reclamation**

- 1 To initiate thin reclamation using the following command:

```
# vxdisk reclaim <diskgroup>
```

For example:

```
# vxdisk reclaim dg100
```

- 2 To monitor the reclamation status, run the following command in another session:

```
# vxtask list
```

```
TASKID  PTID  TYPE/STATE    PCT   PROGRESS
171     RECLAIM/R    00.00% 0/41875931136/0 RECLAIM vol100 dg100
```

The `vxdisk reclaim <diskgroup>` command runs in another session while you run the `vxtask list` command.

## Converting between layered and non-layered volumes

The `vxassist convert` command transforms volume layouts between layered and non-layered forms. The command has the following syntax

```
# vxassist [-b] [-g diskgroup] convert volume [layout=layout] \
  [convert_options]
```

If you specify the `-b` option, the conversion of the volume is a background task.

The following conversion layouts are supported:

<code>stripe-mirror</code>	Mirrored-stripe to striped-mirror
<code>mirror-stripe</code>	Striped-mirror to mirrored-stripe
<code>concat-mirror</code>	Mirrored-concatenated to concatenated-mirror
<code>mirror-concat</code>	Concatenated-mirror to mirrored-concatenated

You can use volume conversion before or after you perform an online relayout to achieve more transformations than would otherwise be possible. During relayout process, a volume may also be converted into an intermediate layout. For example, to convert a volume from a 4-column mirrored-stripe to a 5-column mirrored-stripe, first use `vxassist relayout` to convert the volume to a 5-column striped-mirror as follows:

```
# vxassist -g mydg relayout voll ncol=5
```

When the relayout finishes, use the `vxassist convert` command to change the resulting layered striped-mirror volume to a non-layered mirrored-stripe:

```
# vxassist -g mydg convert voll layout=mirror-stripe
```

---

**Note:** If the system crashes during relayout or conversion, the process continues when the system is rebooted. However, if the system crashes during the first stage of a two-stage relayout and conversion, only the first stage finishes. To complete the operation, you must run `vxassist convert` manually.

---

## Adding a RAID-5 log

You can only have one RAID-5 plex per RAID-5 volume. Additional plexes become RAID-5 log plexes, which log information about data and parity being written to the volume. When you create a RAID-5 volume using the `vxassist` command, a log plex is created for that volume by default.

To add a RAID-5 log to an existing volume, use the following command:

```
# vxassist [-b] [-g diskgroup] addlog volume [loglen=length]
```

If you specify the `-b` option, adding the new log is a background task.

When you add the first log to a volume, you can specify the log length. Any logs that you add subsequently are configured with the same length as the existing log.

For example, to create a log for the RAID-5 volume `volraid`, in the disk group `mydg`, use the following command:

```
# vxassist -g mydg addlog volraid
```

## Adding a RAID-5 log using vxplex

You can also add a RAID-5 log using the `vxplex` command. For example, to attach the RAID-5 log plex `r5log`, to the RAID-5 volume `r5vol`, in the disk group `mydg`, use the following command:

```
# vxplex -g mydg att r5vol r5log
```

The attach operation can only proceed if the size of the new log is large enough to hold all the data on the stripe. If the RAID-5 volume already contains logs, the



new log length is the minimum of each individual log length. The reason is that the new log is a mirror of the old logs.

If the RAID-5 volume is not enabled, the new log is marked as BADLOG and is enabled when the volume is started. However, the contents of the log are ignored.

If the RAID-5 volume is enabled and has other enabled RAID-5 logs, the new log's contents are synchronized with the other logs.

If the RAID-5 volume currently has no enabled logs, the new log is zeroed before it is enabled.

## Removing a RAID-5 log

To identify the plex of the RAID-5 log, use the following command:

```
# vxprint [-g diskgroup] -ht volume
```

where *volume* is the name of the RAID-5 volume. For a RAID-5 log, the output lists a plex with a `STATE` field entry of `LOG`.

To dissociate and remove a RAID-5 log and any associated subdisks from an existing volume, use the following command:

```
# vxplex [-g diskgroup] -o rm dis plex
```

For example, to dissociate and remove the log plex `volraid-02` from `volraid` in the disk group `mydg`, use the following command:

```
# vxplex -g mydg -o rm dis volraid-02
```

You can also remove a RAID-5 log with the `vxassist` command, as follows:

```
# vxassist [-g diskgroup] remove log volume [nlog=n]
```

By default, the `vxassist` command removes one log. To specify the number of logs that remain after the operation, use the optional attribute `nlog=n`.

---

**Note:** When you remove a log and it leaves less than two valid logs on the volume, a warning is printed and the operation is stopped. You can force the operation by specifying the `-f` option with `vxplex` or `vxassist`.

---



# Administering volume snapshots

This chapter includes the following topics:

- [About volume snapshots](#)
- [Traditional third-mirror break-off snapshots](#)
- [Full-sized instant snapshots](#)
- [Space-optimized instant snapshots](#)
- [Emulation of third-mirror break-off snapshots](#)
- [Linked break-off snapshot volumes](#)
- [Cascaded snapshots](#)
- [Creating multiple snapshots](#)
- [Restoring the original volume from a snapshot](#)
- [Creating instant snapshots](#)
- [Creating traditional third-mirror break-off snapshots](#)
- [Adding a version 0 DCO and DCO volume](#)

## About volume snapshots

VxVM can take an image of a volume at a given point in time. This image is called a volume snapshot.

See [“Volume snapshots”](#) on page 62.

You can also take a snapshot of a volume set.

See [“Creating instant snapshots of volume sets”](#) on page 416.

Volume snapshots allow you to make backup copies of your volumes online with minimal interruption to users. You can then use the backup copies to restore data that has been lost due to disk failure, software errors or human mistakes, or to create replica volumes for the purposes of report generation, application development, or testing.

Volume snapshots can also be used to implement off-host online backup.

See [“About off-host processing solutions”](#) on page 455.

A volume snapshot captures the data that exists in a volume at a given point in time. As such, VxVM does not have any knowledge of data that is cached in memory by the overlying file system, or by applications such as databases that have files open in the file system. Snapshots are always crash consistent, that is, the snapshot can be put to use by letting the application perform its recovery. This is similar to how the application recovery occurs after a server crash. If the `fsген` volume usage type is set on a volume that contains a mounted Veritas File System (VxFS), VxVM coordinates with VxFS to flush data that is in the cache to the volume. For other file system types, depending on the capabilities of the file system, there may potentially be inconsistencies between data in memory and in the snapshot.

For databases, a suitable mechanism must additionally be used to ensure the integrity of tablespace data when the volume snapshot is taken. The facility to temporarily suspend file system I/O is provided by most modern database software. For ordinary files in a file system, which may be open to a wide variety of different applications, there may be no way to ensure the complete integrity of the file data other than by shutting down the applications and temporarily unmounting the file system. In many cases, it may only be important to ensure the integrity of file data that is not in active use at the time that you take the snapshot.

There are two alternative methods of creating volume snapshots.

See [“Creating instant snapshots”](#) on page 400.

See [“Creating traditional third-mirror break-off snapshots”](#) on page 431.

Snapshot creation using the `vxsnap` command is the preferred mechanism for implementing point-in-time copy solutions in VxVM. Support for traditional third-mirror snapshots that are created using the `vxassist` command may be removed in a future release.

To recover from the failure of instant snapshot commands, see the *Veritas Volume Manager Troubleshooting Guide*.

# Traditional third-mirror break-off snapshots

Figure 9-1 shows the traditional third-mirror break-off volume snapshot model that is supported by the `vxassist` command.

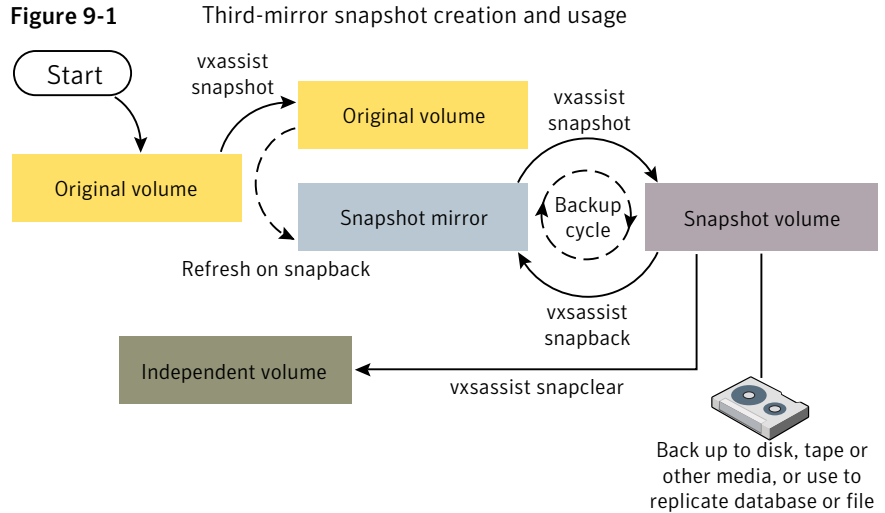

The `vxassist snapstart` command creates a mirror to be used for the snapshot, and attaches it to the volume as a snapshot mirror. As is usual when creating a mirror, the process of copying the volume’s contents to the new snapshot plexes can take some time to complete. (The `vxassist snapabort` cancels this operation and removes the snapshot mirror.)

See “Full-sized instant snapshots” on page 390.

See “Space-optimized instant snapshots” on page 392.

When the attachment is complete, the `vxassist snapshot` command is used to create a new snapshot volume by taking one or more snapshot mirrors to use as its data plexes. The snapshot volume contains a copy of the original volume’s data at the time that you took the snapshot. If more than one snapshot mirror is used, the snapshot volume is itself mirrored.

The command, `vxassist snapback`, can be used to return snapshot plexes to the original volume from which they were snapped, and to resynchronize the data in the snapshot mirrors from the data in the original volume. This enables you to refresh the data in a snapshot after you use it to make a backup. You can use a variation of the same command to restore the contents of the original volume from a snapshot previously taken.

See “Restoring the original volume from a snapshot” on page 399.

The FastResync feature minimizes the time and I/O needed to resynchronize the data in the snapshot. If FastResync is not enabled, a full resynchronization of the data is required.

See “FastResync” on page 64.

Finally, you can use the `vxassist snapclear` command to break the association between the original volume and the snapshot volume. Because the snapshot relationship is broken, no change tracking occurs. Use this command if you do not need to reuse the snapshot volume to create a new PIT.

The use of the `vxassist` command to administer traditional (third-mirror break-off) snapshots is not supported for volumes that are prepared for instant snapshot creation. Use the `vxsnap` command instead.

See “Full-sized instant snapshots” on page 390.

See “Creating instant snapshots” on page 400.

## Full-sized instant snapshots

Full-sized instant snapshots are a variation on the third-mirror volume snapshot model that make a snapshot volume available for I/O access as soon as the snapshot plexes have been created.

Figure 9-2 shows the full-sized instant volume snapshot model.

**Figure 9-2** Full-sized instant snapshot creation and usage in a backup cycle

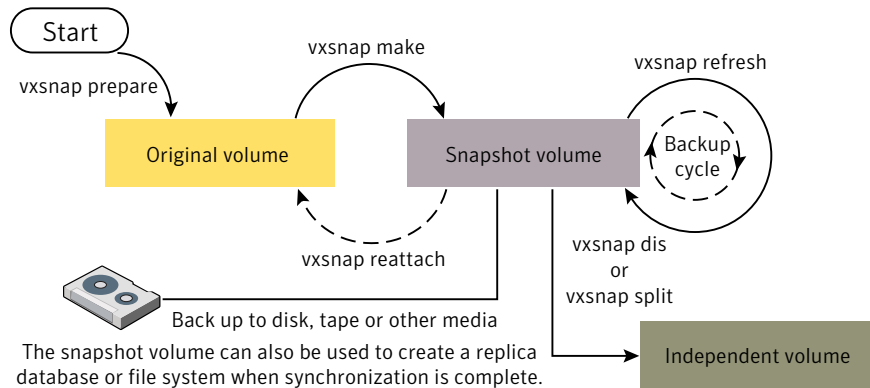

To create an instant snapshot, use the `vxsnap make` command. This command can either be applied to a suitably prepared empty volume that is to be used as the snapshot volume, or it can be used to break off one or more synchronized

plexes from the original volume (which is similar to the way that the `vxassist` command creates its snapshots).

Unlike a third-mirror break-off snapshot created using the `vxassist` command, you can make a backup of a full-sized instant snapshot, instantly refresh its contents from the original volume, or attach its plexes to the original volume, without completely synchronizing the snapshot plexes from the original volume.

VxVM uses a copy-on-write mechanism to ensure that the snapshot volume preserves the contents of the original volume at the time that the snapshot is taken. Any time that the original contents of the volume are about to be overwritten, the original data in the volume is moved to the snapshot volume before the write proceeds. As time goes by, and the contents of the volume are updated, its original contents are gradually relocated to the snapshot volume.

If a read request comes to the snapshot volume, yet the data resides on the original volume (because it has not yet been changed), VxVM automatically and transparently reads the data from the original volume.

If desired, you can perform either a background (non-blocking) or foreground (blocking) synchronization of the snapshot volume. This is useful if you intend to move the snapshot volume into a separate disk group for off-host processing, or you want to turn the snapshot volume into an independent volume.

The `vxsnap refresh` command allows you to update the data in a snapshot, for example, before taking a backup.

The command `vxsnap reattach` attaches snapshot plexes to the original volume, and resynchronizes the data in these plexes from the original volume.

Alternatively, you can use the `vxsnap restore` command to restore the contents of the original volume from a snapshot that you took at an earlier point in time. You can also choose whether or not to keep the snapshot volume after restoration of the original volume is complete.

See [“Restoring the original volume from a snapshot”](#) on page 399.

By default, the FastResync feature of VxVM is used to minimize the time and I/O needed to resynchronize the data in the snapshot mirror. FastResync must be enabled to create instant snapshots.

See [“FastResync”](#) on page 64.

See [“Creating and managing full-sized instant snapshots”](#) on page 408.

An empty volume must be prepared for use by full-sized instant snapshots and linked break-off snapshots.

See [“Creating a volume for use as a full-sized instant or linked break-off snapshot”](#) on page 405.

## Space-optimized instant snapshots

Volume snapshots require the creation of a complete copy of the original volume, and use as much storage space as the copy of the original volume.

In contrast, space-optimized instant snapshots do not require a complete copy of the original volume's storage space. They use a storage cache.

You may find it convenient to configure a single storage cache in a disk group that can be shared by all the volumes in that disk group. If so, the size of the cache that is declared must be the same for each volume's space-optimized snapshot. The cache is stored on disk and is persistent.

See [“Creating a shared cache object”](#) on page 403.

When the original volume is written to, VxVM preserves the original data contents in the cache before the write is committed. As the storage cache typically requires much less storage than the original volume, it is referred to as space-optimized. If the cache approaches full, you can configure VxVM to grow the cache automatically using any available free space in the disk group.

[Figure 9-3](#) shows the instant space-optimized snapshot model.

**Figure 9-3** Space-optimized instant snapshot creation and usage in a backup cycle

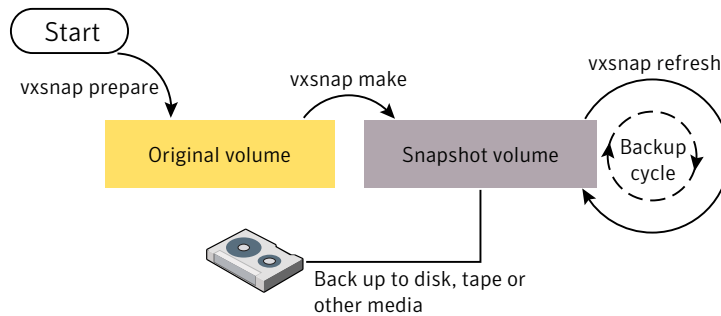

Space-optimized snapshots use a copy-on-write mechanism to make them immediately available for use when they are first created, or when their data is refreshed. Unlike instant snapshots, you cannot enable synchronization on space-optimized snapshots, reattach them to their original volume, or turn them into independent volumes.

See [“Creating and managing space-optimized instant snapshots”](#) on page 406.

A cache object and cache volume must be set up for use by space-optimized instant snapshots.

See [“Creating a shared cache object”](#) on page 403.



## Emulation of third-mirror break-off snapshots

Third-mirror break-off snapshots are suitable for write-intensive volumes (such as for database redo logs) where the copy-on-write mechanism of space-optimized or full-sized instant snapshots might degrade performance.

If you use the `vxsnap prepare` command to enable a volume for use with instant and space-optimized snapshots, you cannot use the `vxassist` snapshot commands to administer snapshots that you create for that volume. If you require snapshots that behave as third-mirror break-off snapshots (that is, they must be fully synchronized before they can be used), there are three ways to achieve this:

- Use the `vxsnap addmir` command to create and attach one or more snapshot mirrors to the volume. When the plexes have been synchronized and are in the `SNAPDONE` state, the `vxsnap make` command can then be used with the `nmirror` attribute to create the snapshot volume. This technique is similar to using the `vxassist snapstart` and `vxassist snapshot` commands. See [“Traditional third-mirror break-off snapshots”](#) on page 389.
- Use the `vxsnap make` command with the `plex` attribute to use one or more existing plexes of a volume as snapshot plexes. The volume must have a sufficient number of available plexes that are in the `ACTIVE` state. The volume must be a non-layered volume with a `mirror` or `mirror-stripe` layout, or a RAID-5 volume that you have converted to a special layered volume and then mirrored. See [“Using a DCO and DCO volume with a RAID-5 volume”](#) on page 363. The plexes in a volume with a `stripe-mirror` layout are mirrored at the sub-volume level, and cannot be used for snapshots.
- Use the `vxsnap make` command with the `sync=yes` and `type=full` attributes specified to create the snapshot volume, and then use the `vxsnap syncwait` command to wait for synchronization of the snapshot volume to complete. See [“Adding snapshot mirrors to a volume”](#) on page 418. See [“Creating and managing third-mirror break-off snapshots”](#) on page 410.

## Linked break-off snapshot volumes

A variant of third-mirror break-off snapshots are linked break-off snapshots, which use the `vxsnap addmir` command to link a specially prepared volume with the data volume. The volume that is used for the snapshot is prepared in the same way as for full-sized instant snapshots. However, unlike full-sized instant snapshots, this volume can be set up in a different disk group from the data volume. This makes linked break-off snapshots especially suitable for recurring off-host

processing applications as it avoids the disk group split/join administrative step. As with third-mirror break-off snapshots, you must wait for the contents of the snapshot volume to be synchronized with the data volume before you can use the `vxsnap make` command to take the snapshot.

When a link is created between a volume and the mirror that will become the snapshot, separate link objects (similar to snap objects) are associated with the volume and with its mirror. The link object for the original volume points to the mirror volume, and the link object for the mirror volume points to the original volume. All I/O is directed to both the original volume and its mirror, and a synchronization of the mirror from the data in the original volume is started.

You can use the `vxprint` command to display the state of link objects, which appear as type `ln`. Link objects can have the following states:

ACTIVE	The mirror volume has been fully synchronized from the original volume. The <code>vxsnap make</code> command can be run to create a snapshot.
ATTACHING	Synchronization of the mirror volume is in progress. The <code>vxsnap make</code> command cannot be used to create a snapshot until the state changes to ACTIVE. The <code>vxsnap snapwait</code> command can be used to wait for the synchronization to complete.
BROKEN	The mirror volume has been detached from the original volume because of an I/O error or an unsuccessful attempt to grow the mirror volume. The <code>vxrecover</code> command can be used to recover the mirror volume in the same way as for a DISABLED volume.  See <a href="#">“Starting a volume”</a> on page 350.

If you resize (grow or shrink) a volume, all its ACTIVE linked mirror volumes are also resized at the same time. The volume and its mirrors can be in the same disk group or in different disk groups. If the operation is successful, the volume and its mirrors will have the same size.

If a volume has been grown, a resynchronization of the grown regions in its linked mirror volumes is started, and the links remain in the ATTACHING state until resynchronization is complete. The `vxsnap snapwait` command can be used to wait for the state to become ACTIVE.

When you use the `vxsnap make` command to create the snapshot volume, this removes the link, and establishes a snapshot relationship between the snapshot volume and the original volume.

The `vxsnap reattach` operation re-establishes the link relationship between the two volumes, and starts a resynchronization of the mirror volume.

See [“Creating and managing linked break-off snapshot volumes”](#) on page 413.

An empty volume must be prepared for use by linked break-off snapshots.

See “[Creating a volume for use as a full-sized instant or linked break-off snapshot](#)” on page 405.

## Cascaded snapshots

Figure 9-4 shows a snapshot hierarchy, known as a snapshot cascade, that can improve write performance for some applications.

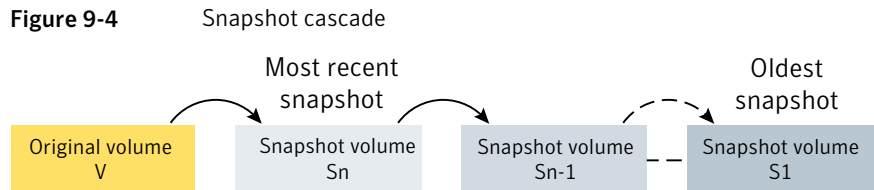

Instead of having several independent snapshots of the volume, it is more efficient to make the older snapshots into children of the latest snapshot.

A snapshot cascade is most likely to be used for regular online backup of a volume where space-optimized snapshots are written to disk but not to tape.

A snapshot cascade improves write performance over the alternative of several independent snapshots, and also requires less disk space if the snapshots are space-optimized. Only the latest snapshot needs to be updated when the original volume is updated. If and when required, the older snapshots can obtain the changed data from the most recent snapshot.

A snapshot may be added to a cascade by specifying the `infrontof` attribute to the `vxsnap make` command when the second and subsequent snapshots in the cascade are created. Changes to blocks in the original volume are only written to the most recently created snapshot volume in the cascade. If an attempt is made to read data from an older snapshot that does not exist in that snapshot, it is obtained by searching recursively up the hierarchy of more recent snapshots.

The following points determine whether it is appropriate to use a snapshot cascade:

- Deletion of a snapshot in the cascade takes time to copy the snapshot’s data to the next snapshot in the cascade.
- The reliability of a snapshot in the cascade depends on all the newer snapshots in the chain. Thus the oldest snapshot in the cascade is the most vulnerable.
- Reading from a snapshot in the cascade may require data to be fetched from one or more other snapshots in the cascade.

For these reasons, it is recommended that you do not attempt to use a snapshot cascade with applications that need to remove or split snapshots from the cascade. In such cases, it may be more appropriate to create a snapshot of a snapshot as described in the following section.

See “[Adding a snapshot to a cascaded snapshot hierarchy](#)” on page 419.

---

**Note:** Only unsynchronized full-sized or space-optimized instant snapshots are usually cascaded. It is of little utility to create cascaded snapshots if the `infrontof` snapshot volume is fully synchronized (as, for example, with break-off type snapshots).

---

## Creating a snapshot of a snapshot

[Figure 9-5](#) creation of a snapshot of an existing snapshot.

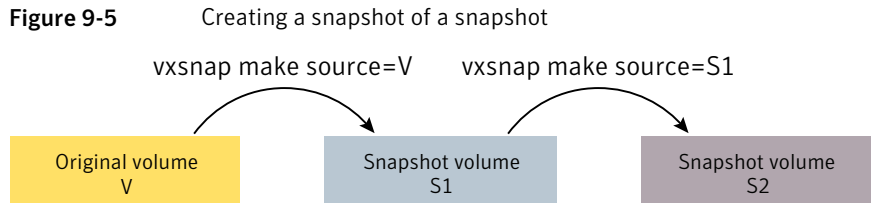

Even though the arrangement of the snapshots in this figure appears similar to a snapshot cascade, the relationship between the snapshots is not recursive. When reading from the snapshot `s2`, data is obtained directly from the original volume, `v`, if it does not exist in `s1` itself.

See [Figure 9-4](#) on page 395.

Such an arrangement may be useful if the snapshot volume, `s1`, is critical to the operation. For example, `s1` could be used as a stable copy of the original volume, `v`. The additional snapshot volume, `s2`, can be used to restore the original volume if that volume becomes corrupted. For a database, you might need to replay a redo log on `s2` before you could use it to restore `v`.

[Figure 9-6](#) shows the sequence of steps that would be required to restore a database.

**Figure 9-6** Using a snapshot of a snapshot to restore a database

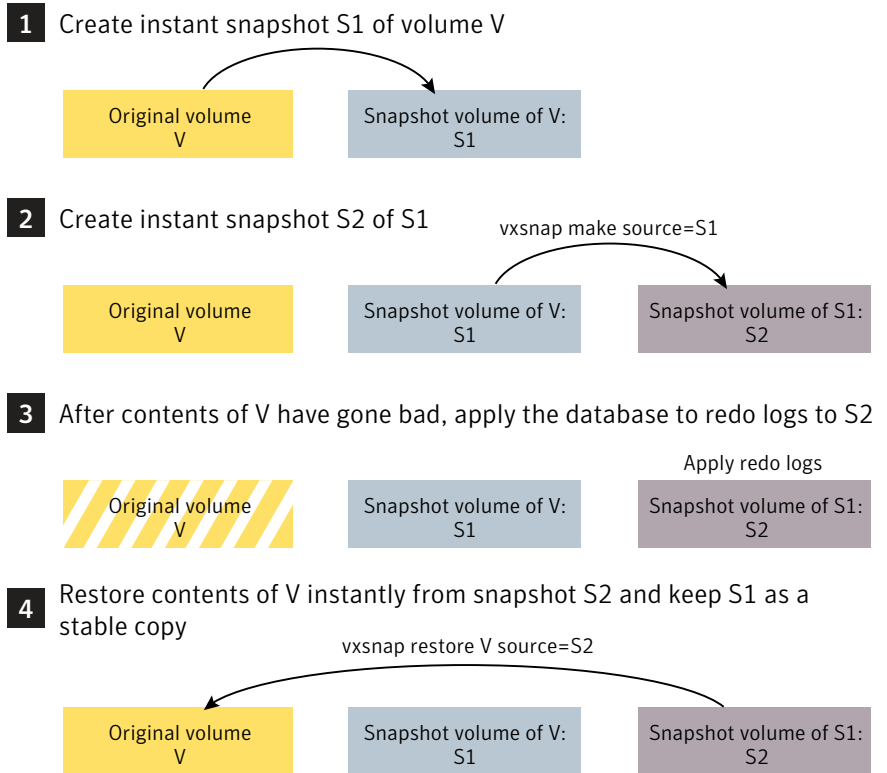

If you have configured snapshots in this way, you may wish to make one or more of the snapshots into independent volumes. There are two `vxsnap` commands that you can use to do this:

- `vxsnap dis` dissociates a snapshot and turns it into an independent volume. The snapshot to be dissociated must have been fully synchronized from its parent. If a snapshot volume has a child snapshot volume, the child must also have been fully synchronized. If the command succeeds, the child snapshot becomes a snapshot of the original volume.

Figure 9-7 shows the effect of applying the `vxsnap dis` command to snapshots with and without dependent snapshots.

**Figure 9-7** Dissociating a snapshot volume

`vxsnap dis` is applied to snapshot S2, which has no snapshots of its own

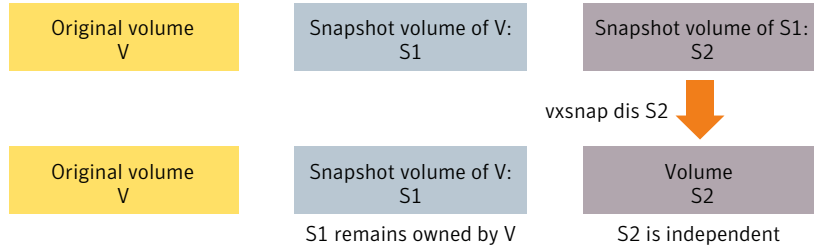

`vxsnap dis` is applied to snapshot S1, which has one snapshot S2

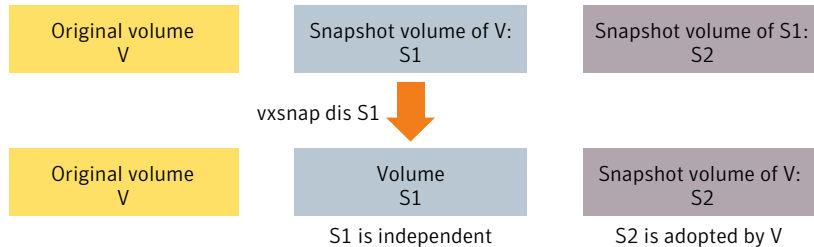

- `vxsnap split` dissociates a snapshot and its dependent snapshots from its parent volume. The snapshot that is to be split must have been fully synchronized from its parent volume.

Figure 9-8 shows the operation of the `vxsnap split` command.

**Figure 9-8** Splitting snapshots

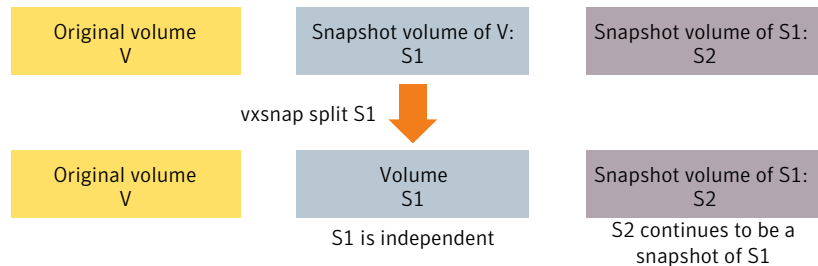

## Creating multiple snapshots

To make it easier to create snapshots of several volumes at the same time, both the `vxsnap make` and `vxassist snapshot` commands accept more than one volume name as their argument.

For traditional snapshots, you can create snapshots of all the volumes in a single disk group by specifying the option `-o allvols` to the `vxassist snapshot` command.

By default, each replica volume is named `SNAPnumber-volume`, where `number` is a unique serial number, and `volume` is the name of the volume for which a snapshot is being taken. This default can be overridden by using the option `-o name=pattern`.

See the `vxassist(1M)` manual page.

See the `vxsnap(1M)` manual page.

You can create a snapshot of all volumes that form a logical group; for example, all the volumes that conform to a database instance.

## Restoring the original volume from a snapshot

For traditional snapshots, the snapshot plex is resynchronized from the data in the original volume during a `vxassist snapback` operation.

[Figure 9-9](#) shows an alternative where the snapshot overwrites the original volume.

**Figure 9-9** Resynchronizing an original volume from a snapshot

Refresh on snapback

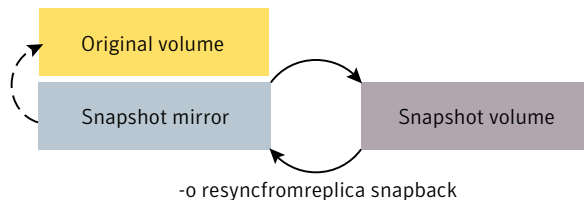

Specifying the option `-o resyncfromreplica` to `vxassist` resynchronizes the original volume from the data in the snapshot.

---

**Warning:** The original volume must not be in use during a `snapback` operation that specifies the option `-o resyncfromreplica` to resynchronize the volume from a snapshot. Stop any application, such as a database, and unmount any file systems that are configured to use the volume.

---

For instant snapshots, the `vxsnap restore` command may be used to restore the contents of the original volume from an instant snapshot or from a volume derived from an instant snapshot. The volume that is used to restore the original volume

can either be a true backup of the contents of the original volume at some point in time, or it may have been modified in some way (for example, by applying a database log replay or by running a file system checking utility such as `fsck`). All synchronization of the contents of this backup must have been completed before the original volume can be restored from it. The original volume is immediately available for use while its contents are being restored.

See [“Restoring a volume from an instant snapshot”](#) on page 422.

## Creating instant snapshots

VxVM allows you to make instant snapshots by using the `vxsnap` command.

You can also take instant snapshots of RAID-5 volumes that have been converted to a special layered volume layout by the addition of a DCO and DCO volume.

See [“Using a DCO and DCO volume with a RAID-5 volume”](#) on page 363.

A plex in a full-sized instant snapshot requires as much space as the original volume. If you instead make a space-optimized instant snapshot of a volume, this only requires enough storage to record the original contents of the parent volume as they are changed during the life of the snapshot.

The recommended approach to performing volume backup from the command line, or from a script, is to use the `vxsnap` command. The `vxsnap prepare` and `make` tasks allow you to back up volumes online with minimal disruption to users.

`vxsnap prepare` creates a DCO and DCO volume and associates this with the original volume. It also enables Persistent FastResync.

`vxsnap make` creates an instant snapshot that is immediately available for making a backup. After the snapshot has been taken, read requests for data in the original volume are satisfied by reading either from a non-updated region of the original volume, or from the copy of the original contents of an updated region that have been recorded by the snapshot.

---

**Note:** Synchronization of a full-sized instant snapshot from the original volume is enabled by default. If you specify the `syncing=no` attribute to `vxsnap make`, this disables synchronization, and the contents of the instant snapshot are unlikely ever to become fully synchronized with the contents of the original volume at the point in time that the snapshot was taken. In such a case, the snapshot cannot be used for off-host processing, nor can it become an independent volume.

---



You can immediately retake a full-sized or space-optimized instant snapshot at any time by using the `vxsnap refresh` command. If a fully synchronized instant snapshot is required, the new resynchronization must first complete.

To create instant snapshots of volume sets, use volume set names in place of volume names in the `vxsnap` command.

See [“Creating instant snapshots of volume sets”](#) on page 416.

When using the `vxsnap prepare` or `vxassist make` commands to make a volume ready for instant snapshot operations, if the specified region size exceeds half the value of the tunable `voliomem_maxpool_sz`, the operation succeeds but gives a warning such as the following (for a system where `voliomem_maxpool_sz` is set to 12MB):

```
VxVM vxassist WARNING V-5-1-0 Specified regionsize is
larger than the limit on the system
(voliomem_maxpool_sz/2=6144k).
```

If this message is displayed, `vxsnap make`, `refresh` and `restore` operations on such volumes fail as they might potentially hang the system. Such volumes can be used only for break-off snapshot operations using the `reattach` and `make` operations.

To make the volumes usable for instant snapshot operations, use `vxsnap unprepare` on the volume, and then use `vxsnap prepare` to re-prepare the volume with a region size that is less than half the size of `voliomem_maxpool_sz` (in this example, 1MB):

```
# vxsnap -g mydg -f unprepare voll
# vxsnap -g mydg prepare voll regionsize=1M
```

See [“Preparing to create instant and break-off snapshots”](#) on page 402.

See [“Creating and managing space-optimized instant snapshots”](#) on page 406.

See [“Creating and managing full-sized instant snapshots”](#) on page 408.

See [“Creating and managing third-mirror break-off snapshots”](#) on page 410.

See [“Creating and managing linked break-off snapshot volumes”](#) on page 413.

## Preparing to create instant and break-off snapshots

### To prepare a volume for the creation of instant and break-off snapshots

- 1 Use the following commands to see if the volume has a version 20 data change object (DCO) and DCO volume that allow instant snapshots and Persistent FastResync to be used with the volume, and to check that FastResync is enabled on the volume:

```
# vxprint -g volumedg -F%instant volume
# vxprint -g volumedg -F%fastresync volume
```

If both commands return a value of `on`, skip to step 3. Otherwise continue with step 2.

- 2 To prepare a volume for instant snapshots, use the following command:

```
# vxsnap [-g diskgroup] prepare volume [regionsize=size] \
  [ndcomirs=number] [alloc=storage_attributes]
```

Run the `vxsnap prepare` command on a volume only if it does not have a version 20 DCO volume (for example, if you have run the `vxsnap unprepare` command on the volume).

See [“Creating a volume with a version 20 DCO volume”](#) on page 324.

See [“Preparing a volume for DRL and instant snapshots”](#) on page 360.

See [“Removing support for DRL and instant snapshots from a volume”](#) on page 365.

For example, to prepare the volume, `myvol`, in the disk group, `mydg`, use the following command:

```
# vxsnap -g mydg prepare myvol regionsize=128k ndcomirs=2 \
  alloc=mydg10,mydg11
```

This example creates a DCO object and redundant DCO volume with two plaxes located on disks `mydg10` and `mydg11`, and associates them with `myvol`. The region size is also increased to 128KB from the default size of 64KB. The region size must be a power of 2, and be greater than or equal to 16KB. A smaller value requires more disk space for the change maps, but the finer granularity provides faster resynchronization.

- 3 If you need several space-optimized instant snapshots for the volumes in a disk group, you may find it convenient to create a single shared cache object in the disk group rather than a separate cache object for each snapshot.

See [“Creating a shared cache object”](#) on page 403.

For full-sized instant snapshots and linked break-off snapshots, you must prepare a volume that is to be used as the snapshot volume. This volume must be the same size as the data volume for which the snapshot is being created, and it must also have the same region size.

See [“Creating a volume for use as a full-sized instant or linked break-off snapshot”](#) on page 405.

## Creating a shared cache object

### To create a shared cache object

- 1 Decide on the following characteristics that you want to allocate to the cache volume that underlies the cache object:
  - The cache volume size should be sufficient to record changes to the parent volumes during the interval between snapshot refreshes. A suggested value is 10% of the total size of the parent volumes for a refresh interval of 24 hours.
  - The cache volume can be mirrored for redundancy.
  - If the cache volume is mirrored, space is required on at least as many disks as it has mirrors. These disks should not be shared with the disks used for the parent volumes. The disks should not be shared with disks used by critical volumes to avoid impacting I/O performance for critical volumes, or hindering disk group split and join operations.
- 2 Having decided on its characteristics, use the `vxassist` command to create the cache volume. The following example creates a mirrored cache volume, `cachevol`, with size 1GB in the disk group, `mydg`, on the disks `mydg16` and `mydg17`:

```
# vxassist -g mydg make cachevol 1g layout=mirror \  
  init=active mydg16 mydg17
```

The attribute `init=active` makes the cache volume immediately available for use.

- 3 Use the `vxmake cache` command to create a cache object on top of the cache volume that you created in the previous step:

```
# vxmake [-g diskgroup] cache cache_object \  
  cachevolname=volume [regionsize=size] [autogrow=on] \  
  [highwatermark=hwmk] [autogrowby=agbvalue] \  
  [maxautogrow=maxagbvalue]
```

If the region size, `regionsize`, is specified, it must be a power of 2, and be greater than or equal to 16KB (16k). If not specified, the region size of the cache is set to 64KB.

All space-optimized snapshots that share the cache must have a region size that is equal to or an integer multiple of the region size set on the cache. Snapshot creation also fails if the original volume's region size is smaller than the cache's region size.

If the region size of a space-optimized snapshot differs from the region size of the cache, this can degrade the system's performance compared to the case where the region sizes are the same.

To grow the cache in size as required, specify `autogrow=on`. By default, `autogrow=ff`.

In the following example, the cache object, `cobjmydg`, is created over the cache volume, `cachevol`, the region size of the cache is set to 32KB, and the `autogrow` feature is enabled:

```
# vxmake -g mydg cache cobjmydg cachevolname=cachevol \  
  regionsize=32k autogrow=on
```

- 4 Enable the cache object using the following command:

```
# vxcache [-g diskgroup] start cache_object
```

For example to start the cache object, `cobjmydg`:

```
# vxcache -g mydg start cobjmydg
```

See “[Removing a cache](#)” on page 430.

## Creating a volume for use as a full-sized instant or linked break-off snapshot

To create an empty volume for use by a full-sized instant snapshot or a linked break-off snapshot

- 1 Use the `vxprint` command on the original volume to find the required size for the snapshot volume.

```
# LEN=`vxprint [-g diskgroup] -F%len volume`
```

The command as shown assumes a Bourne-type shell such as `sh`, `ksh` or `bash`. You may need to modify the command for other shells such as `csh` or `tcsh`.

- 2 Use the `vxprint` command on the original volume to discover the name of its DCO:

```
# DCONAME=`vxprint [-g diskgroup] -F%dco_name volume`
```

- 3 Use the `vxprint` command on the DCO to discover its region size (in blocks):

```
# RSZ=`vxprint [-g diskgroup] -F%regionsz $DCONAME`
```

- 4 Use the `vxassist` command to create a volume, *snapvol*, of the required size and redundancy, together with a version 20 DCO volume with the correct region size:

```
# vxassist [-g diskgroup] make snapvol $LEN \
  [layout=mirror nmirror=number] logtype=dco drl=off \
  dcoverion=20 [ndcomirror=number] regionsz=$RSZ \
  init=active [storage_attributes]
```

Specify the same number of DCO mirrors (`ndcomirror`) as the number of mirrors in the volume (`nmirror`). The `init=active` attribute makes the volume available immediately. You can use storage attributes to specify which disks should be used for the volume.

As an alternative to creating the snapshot volume and its DCO volume in a single step, you can first create the volume, and then prepare it for instant snapshot operations as shown here:

```
# vxassist [-g diskgroup] make snapvol $LEN \
  [layout=mirror nmirror=number] init=active \
  [storage_attributes]
# vxsnap [-g diskgroup] prepare snapvol [ndcomirs=number] \
  regionsize=$RSZ [storage_attributes]
```

## Creating and managing space-optimized instant snapshots

Space-optimized instant snapshots are not suitable for write-intensive volumes (such as for database redo logs) because the copy-on-write mechanism may degrade performance.

To split the volume and snapshot into separate disk groups (for example, to perform off-host processing), you must use a fully synchronized full-sized instant, third-mirror break-off or linked break-off snapshot (which do not require a cache object). You cannot use a space-optimized instant snapshot.

Creation of space-optimized snapshots that use a shared cache fails if the region size specified for the volume is smaller than the region size set on the cache.

If the region size of a space-optimized snapshot differs from the region size of the cache, this can degrade the system's performance compared to the case where the region sizes are the same.

See [“Creating a shared cache object”](#) on page 403.

The attributes for a snapshot are specified as a tuple to the `vxsnap make` command. This command accepts multiple tuples. One tuple is required for each snapshot that is being created. Each element of a tuple is separated from the next by a slash character (/). Tuples are separated by white space.

### To create and manage a space-optimized instant snapshot

- 1 Use the `vxsnap make` command to create a space-optimized instant snapshot. This snapshot can be created by using an existing cache object in the disk group, or a new cache object can be created.
  - To create a space-optimized instant snapshot, `snapvol`, that uses a named shared cache object:

```
# vxsnap [-g diskgroup] make source=vol/newvol=snapvol\  
/cache=cacheobject [alloc=storage_attributes]
```

For example, to create the space-optimized instant snapshot, `snap3myvol`, of the volume, `myvol`, in the disk group, `mydg`, on the disk `mydg14`, and which uses the shared cache object, `cobjmydg`, use the following command:

```
# vxsnap -g mydg make source=myvol/newvol=snap3myvol\  
/cache=cobjmydg alloc=mydg14
```

See [“Creating a shared cache object”](#) on page 403.

- To create a space-optimized instant snapshot, `snapvol`, and also create a cache object for it to use:

```
# vxsnap [-g diskgroup] make source=vol/newvol=snapvol\
[/cachesize=size]/autogrow=yes]/ncachemirror=number]\
[alloc=storage_attributes]
```

The `cachesize` attribute determines the size of the cache relative to the size of the volume. The `autogrow` attribute determines whether VxVM will automatically enlarge the cache if it is in danger of overflowing. By default, the cache is not grown.

If `autogrow` is enabled, but the cache cannot be grown, VxVM disables the oldest and largest snapshot that is using the same cache, and releases its cache space for use.

The `ncachemirror` attribute specifies the number of mirrors to create in the cache volume. For backup purposes, the default value of 1 should be sufficient.

For example, to create the space-optimized instant snapshot, `snap4myvol`, of the volume, `myvol`, in the disk group, `mydg`, on the disk `mydg15`, and which uses a newly allocated cache object that is 1GB in size, but which can automatically grow in size, use the following command:

```
# vxsnap -g mydg make source=myvol/new=snap4myvol\
/cachesize=1g/autogrow=yes alloc=mydg15
```

If a cache is created implicitly by specifying `cachesize`, and `ncachemirror` is specified to be greater than 1, a DCO is attached to the cache volume to enable dirty region logging (DRL). DRL allows fast recovery of the cache backing store after a system crash. The DCO is allocated on the same disks as those that are occupied by the DCO of the source volume. This is done to allow the cache and the source volume to remain in the same disk group for disk group move, split and join operations.

- 2 Use `fsck` (or some utility appropriate for the application running on the volume) to clean the temporary volume's contents. For example, you can use this command with a VxFS file system:

```
# fsck -F vxfs /dev/vx/rdisk/diskgroup/snapshot
```

The specified device must have a valid entry in the `/etc/vfstab` file.

- 3 To backup the data in the snapshot, use an appropriate utility or operating system command to copy the contents of the snapshot to tape, or to some other backup medium.
- 4 You now have the following options:
  - Refresh the contents of the snapshot. This creates a new point-in-time image of the original volume ready for another backup. If synchronization

was already in progress on the snapshot, this operation may result in large portions of the snapshot having to be resynchronized.

See [“Refreshing an instant snapshot”](#) on page 420.

- Restore the contents of the original volume from the snapshot volume. The space-optimized instant snapshot remains intact at the end of the operation.

See [“Restoring a volume from an instant snapshot”](#) on page 422.

- Destroy the snapshot.

See [“Removing an instant snapshot”](#) on page ?.

## Creating and managing full-sized instant snapshots

Full-sized instant snapshots are not suitable for write-intensive volumes (such as for database redo logs) because the copy-on-write mechanism may degrade the performance of the volume.

For full-sized instant snapshots, you must prepare a volume that is to be used as the snapshot volume. This must be the same size as the volume for which the snapshot is being created, and it must also have the same region size.

See [“Creating a volume for use as a full-sized instant or linked break-off snapshot”](#) on page 405.

The attributes for a snapshot are specified as a tuple to the `vxsnap make` command. This command accepts multiple tuples. One tuple is required for each snapshot that is being created. Each element of a tuple is separated from the next by a slash character (/). Tuples are separated by white space.

### To create and manage a full-sized instant snapshot

- 1 To create a full-sized instant snapshot, use the following form of the `vxsnap make` command:

```
# vxsnap [-g diskgroup] make source=volume/snapvol=snapvol\  
[/snapdg=snapdiskgroup] [/syncing=off]
```

The command specifies the volume, *snapvol*, that you prepared earlier.

For example, to use the prepared volume, *snap1myvol*, as the snapshot for the volume, *myvol*, in the disk group, *mydg*, use the following command:

```
# vxsnap -g mydg make source=myvol/snapvol=snap1myvol
```

For full-sized instant snapshots that are created from an empty volume, background synchronization is enabled by default (equivalent to specifying the `syncing=on` attribute). To move a snapshot into a separate disk group, or



to turn it into an independent volume, you must wait for its contents to be synchronized with those of its parent volume.

You can use the `vxsnap syncwait` command to wait for the synchronization of the snapshot volume to be completed, as shown here:

```
# vxsnap [-g diskgroup] syncwait snapvol
```

For example, you would use the following command to wait for synchronization to finish on the snapshot volume, `snap2myvol`:

```
# vxsnap -g mydg syncwait snap2myvol
```

This command exits (with a return code of zero) when synchronization of the snapshot volume is complete. The snapshot volume may then be moved to another disk group or turned into an independent volume.

See [“Controlling instant snapshot synchronization”](#) on page 426.

If required, you can use the following command to test if the synchronization of a volume is complete:

```
# vxprint [-g diskgroup] -F%incomplete snapvol
```

This command returns the value `off` if synchronization of the volume, `snapvol`, is complete; otherwise, it returns the value `on`.

You can also use the `vxsnap print` command to check on the progress of synchronization.

See [“Displaying instant snapshot information”](#) on page 424.

If you do not want to move the snapshot into a separate disk group, or to turn it into an independent volume, specify the `syncing=off` attribute. This avoids unnecessary system overhead. For example, to turn off synchronization when creating the snapshot of the volume, `myvol`, you would use the following form of the `vxsnap make` command:

```
# vxsnap -g mydg make source=myvol/snapvol=snap1myvol\  
/syncing=off
```

- 2 Use `fsck` (or some utility appropriate for the application running on the volume) to clean the temporary volume’s contents. For example, you can use this command with a VxFS file system:

```
# fsck -F vxfs /dev/vx/rdisk/diskgroup/snapshot
```

The specified device must have a valid entry in the `/etc/vfstab` file.

- 3 To backup the data in the snapshot, use an appropriate utility or operating system command to copy the contents of the snapshot to tape, or to some other backup medium.
- 4 You now have the following options:
  - Refresh the contents of the snapshot. This creates a new point-in-time image of the original volume ready for another backup. If synchronization was already in progress on the snapshot, this operation may result in large portions of the snapshot having to be resynchronized.  
See [“Refreshing an instant snapshot”](#) on page 420.
  - Reattach some or all of the plexes of the snapshot volume with the original volume.  
See [“Reattaching an instant snapshot”](#) on page 420.
  - Restore the contents of the original volume from the snapshot volume. You can choose whether none, a subset, or all of the plexes of the snapshot volume are returned to the original volume as a result of the operation.  
See [“Restoring a volume from an instant snapshot”](#) on page 422.
  - Dissociate the snapshot volume entirely from the original volume. This may be useful if you want to use the copy for other purposes such as testing or report generation. If desired, you can delete the dissociated volume.  
See [“Dissociating an instant snapshot”](#) on page 423.
  - If the snapshot is part of a snapshot hierarchy, you can also choose to split this hierarchy from its parent volumes.  
See [“Splitting an instant snapshot hierarchy”](#) on page 424.

## Creating and managing third-mirror break-off snapshots

Break-off snapshots are suitable for write-intensive volumes, such as database redo logs.

To turn one or more existing plexes in a volume into a break-off instant snapshot volume, the volume must be a non-layered volume with a `mirror` or `mirror-stripe` layout, or a RAID-5 volume that you have converted to a special layered volume and then mirrored. The plexes in a volume with a `stripe-mirror` layout are mirrored at the subvolume level, and cannot be broken off.

See [“Using a DCO and DCO volume with a RAID-5 volume”](#) on page 363.

The attributes for a snapshot are specified as a tuple to the `vxsnap make` command. This command accepts multiple tuples. One tuple is required for each snapshot that is being created. Each element of a tuple is separated from the next by a slash character (/). Tuples are separated by white space.

### To create and manage a third-mirror break-off snapshot

- 1 To create the snapshot, you can either take some of the existing `ACTIVE` plexes in the volume, or you can use the following command to add new snapshot mirrors to the volume:

```
# vxsnap [-b] [-g diskgroup] addmir volume [nmirror=N] \  
    [alloc=storage_attributes]
```

By default, the `vxsnap addmir` command adds one snapshot mirror to a volume unless you use the `nmirror` attribute to specify a different number of mirrors. The mirrors remain in the `SNAPATT` state until they are fully synchronized. The `-b` option can be used to perform the synchronization in the background. Once synchronized, the mirrors are placed in the `SNAPDONE` state.

For example, the following command adds 2 mirrors to the volume, `vol1`, on disks `mydg10` and `mydg11`:

```
# vxsnap -g mydg addmir vol1 nmirror=2 alloc=mydg10,mydg11
```

If you specify the `-b` option to the `vxsnap addmir` command, you can use the `vxsnap snapwait` command to wait for synchronization of the snapshot plexes to complete, as shown in this example:

```
# vxsnap -g mydg snapwait vol1 nmirror=2
```

- 2 To create a third-mirror break-off snapshot, use the following form of the `vxsnap make` command.

```
# vxsnap [-g diskgroup] make source=volume[/newvol=snapvol]\
{/plex=plex1[,plex2,...]||nmirror=number]}
```

Either of the following attributes may be specified to create the new snapshot volume, *snapvol*, by breaking off one or more existing plexes in the original volume:

<code>plex</code>	Specifies the plexes in the existing volume that are to be broken off.
<code>nmirror</code>	Specifies how many plexes are to be broken off. This attribute can only be used with plexes that are in the <code>SNAPDONE</code> state. (Such plexes could have been added to the volume by using the <code>vxsnap addmir</code> command.)

Snapshots that are created from one or more `ACTIVE` or `SNAPDONE` plexes in the volume are already synchronized by definition.

For backup purposes, a snapshot volume with one plex should be sufficient.

For example, to create the instant snapshot volume, *snap2myvol*, of the volume, *myvol*, in the disk group, *mydg*, from a single existing plex in the volume, use the following command:

```
# vxsnap -g mydg make source=myvol/newvol=snap2myvol/nmirror=1
```

The next example shows how to create a mirrored snapshot from two existing plexes in the volume:

```
# vxsnap -g mydg make source=myvol/newvol=snap2myvol/plex=myvol-03,myvol-04
```

- 3 Use `fsck` (or some utility appropriate for the application running on the volume) to clean the temporary volume's contents. For example, you can use this command with a VxFS file system:

```
# fsck -F vxfs /dev/vx/rdisk/diskgroup/snapshot
```

The specified device must have a valid entry in the `/etc/vfstab` file.

- 4 To backup the data in the snapshot, use an appropriate utility or operating system command to copy the contents of the snapshot to tape, or to some other backup medium.
- 5 You now have the following options:

- Refresh the contents of the snapshot. This creates a new point-in-time image of the original volume ready for another backup. If synchronization was already in progress on the snapshot, this operation may result in large portions of the snapshot having to be resynchronized.  
See [“Refreshing an instant snapshot”](#) on page 420.
- Reattach some or all of the plexes of the snapshot volume with the original volume.  
See [“Reattaching an instant snapshot”](#) on page 420.
- Restore the contents of the original volume from the snapshot volume. You can choose whether none, a subset, or all of the plexes of the snapshot volume are returned to the original volume as a result of the operation.  
See [“Restoring a volume from an instant snapshot”](#) on page 422.
- Dissociate the snapshot volume entirely from the original volume. This may be useful if you want to use the copy for other purposes such as testing or report generation. If desired, you can delete the dissociated volume.  
See [“Dissociating an instant snapshot”](#) on page 423.
- If the snapshot is part of a snapshot hierarchy, you can also choose to split this hierarchy from its parent volumes.  
See [“Splitting an instant snapshot hierarchy”](#) on page 424.

## Creating and managing linked break-off snapshot volumes

Break-off snapshots are suitable for write-intensive volumes. Specifically, they are used for off-host processing, because the snapshot could be in a different data group to start with and could avoid data group split/join operations

For linked break-off snapshots, you must prepare a volume that is to be used as the snapshot volume. This must be the same size as the volume for which the snapshot is being created, and it must also have the same region size.

See [“Creating a volume for use as a full-sized instant or linked break-off snapshot”](#) on page 405.

The attributes for a snapshot are specified as a tuple to the `vxsnap make` command. This command accepts multiple tuples. One tuple is required for each snapshot that is being created. Each element of a tuple is separated from the next by a slash character (/). Tuples are separated by white space.

**To create and manage a linked break-off snapshot**

- 1 Use the following command to link the prepared snapshot volume, *snapvol*, to the data volume:

```
# vxsnap [-g diskgroup] [-b] addmir volume mirvol=snapvol \  
[mirdg=snapdg]
```

The optional `mirdg` attribute can be used to specify the snapshot volume's current disk group, *snapdg*. The `-b` option can be used to perform the synchronization in the background. If the `-b` option is not specified, the command does not return until the link becomes `ACTIVE`.

For example, the following command links the prepared volume, *prepsnap*, in the disk group, *mynsnapdg*, to the volume, *vol1*, in the disk group, *mydg*:

```
# vxsnap -g mydg -b addmir vol1 mirvol=prepsnap mirdg=mynsnapdg
```

If the `-b` option is specified, you can use the `vxsnap snapwait` command to wait for the synchronization of the linked snapshot volume to complete, as shown in this example:

```
# vxsnap -g mydg snapwait vol1 mirvol=prepsnap mirdg=mynsnapvoldg
```

- 2 To create a linked break-off snapshot, use the following form of the `vxsnap make` command.

```
# vxsnap [-g diskgroup] make source=volume/snapvol=snapvol \  
[/snapdg=snapdiskgroup]
```

The `snapdg` attribute must be used to specify the snapshot volume's disk group if this is different from that of the data volume.

For example, to use the prepared volume, *prepsnap*, as the snapshot for the volume, *vol1*, in the disk group, *mydg*, use the following command:

```
# vxsnap -g mydg make source=vol1/snapvol=prepsnap/snapdg=mynsnapdg
```

- 3 Use `fsck` (or some utility appropriate for the application running on the volume) to clean the temporary volume's contents. For example, you can use this command with a VxFS file system:

```
# fsck -F vxfs /dev/vx/rdisk/diskgroup/snapshot
```

The specified device must have a valid entry in the `/etc/vfstab` file.

- 4 To backup the data in the snapshot, use an appropriate utility or operating system command to copy the contents of the snapshot to tape, or to some other backup medium.
- 5 You now have the following options:
  - Refresh the contents of the snapshot. This creates a new point-in-time image of the original volume ready for another backup. If synchronization was already in progress on the snapshot, this operation may result in large portions of the snapshot having to be resynchronized. See [“Refreshing an instant snapshot”](#) on page 420.
  - Reattach the snapshot volume with the original volume. This operation is not possible if the linked volume and snapshot are in different disk groups. See [“Reattaching a linked break-off snapshot volume”](#) on page 421.
  - Dissociate the snapshot volume entirely from the original volume. This may be useful if you want to use the copy for other purposes such as testing or report generation. If desired, you can delete the dissociated volume. See [“Dissociating an instant snapshot”](#) on page 423.
  - If the snapshot is part of a snapshot hierarchy, you can also choose to split this hierarchy from its parent volumes. See [“Splitting an instant snapshot hierarchy”](#) on page 424.

## Creating multiple instant snapshots

You can create multiple instant snapshots for all volumes that form a consistent group. The `vxsnap make` command accepts multiple tuples that define the source and snapshot volumes names as their arguments. For example, to create three instant snapshots, each with the same redundancy, from specified storage, the following form of the command can be used:

```
# vxsnap [-g diskgroup] make source=vol1/snapvol=snapvol1\  
source=vol2/snapvol=snapvol2 source=vol3/snapvol=snapvol3
```

The snapshot volumes (*snapvol1*, *snapvol2* and so on) must have been prepared in advance.

See [“Creating a volume for use as a full-sized instant or linked break-off snapshot”](#) on page 405.

The specified source volumes (*vol1*, *vol2* and so on) may be the same volume or they can be different volumes.

If all the snapshots are to be space-optimized and to share the same cache, the following form of the command can be used:

```
# vxsnap [-g diskgroup] make \
  source=vol1/newvol=snapvol1/cache=cacheobj \
  source=vol2/newvol=snapvol2/cache=cacheobj \
  source=vol3/newvol=snapvol3/cache=cacheobj \
  [alloc=storage_attributes]
```

The `vxsnap make` command also allows the snapshots to be of different types, have different redundancy, and be configured from different storage, as shown here:

```
# vxsnap [-g diskgroup] make source=vol1/snapvol=snapvol1 \
  source=vol2[/newvol=snapvol2]/cache=cacheobj\
[/alloc=storage_attributes2] [/nmirror=number2]
  source=vol3[/newvol=snapvol3] [/alloc=storage_attributes3]\
/nmirror=number3
```

In this example, *snapvol1* is a full-sized snapshot that uses a prepared volume, *snapvol2* is a space-optimized snapshot that uses a prepared cache, and *snapvol3* is a break-off full-sized snapshot that is formed from plexes of the original volume.

An example of where you might want to create mixed types of snapshots at the same time is when taking snapshots of volumes containing database redo logs and database tables:

```
# vxsnap -g mydg make \
  source=logv1/newvol=snplogv1/drl=sequential/nmirror=1 \
  source=logv2/newvol=snplogv2/drl=sequential/nmirror=1 \
  source=datav1/newvol=snpdatav1/cache=mydgcobj/drl=on \
  source=datav2/newvol=snpdatav2/cache=mydgcobj/drl=on
```

In this example, sequential DRL is enabled for the snapshots of the redo log volumes, and normal DRL is applied to the snapshots of the volumes that contain the database tables. The two space-optimized snapshots are configured to share the same cache object in the disk group. Also note that break-off snapshots are used for the redo logs as such volumes are write intensive.

## Creating instant snapshots of volume sets

Volume set names can be used in place of volume names with the following `vxsnap` operations on instant snapshots: `addmir`, `dis`, `make`, `prepare`, `reattach`, `refresh`, `restore`, `rmmir`, `split`, `syncpause`, `syncresume`, `syncstart`, `syncstop`, `syncwait`, and `unprepare`.

The procedure for creating an instant snapshot of a volume set is the same as that for a standalone volume. However, there are certain restrictions if a full-sized instant snapshot is to be created from a prepared volume set. A full-sized instant



snapshot of a volume set must itself be a volume set with the same number of volumes, and the same volume sizes and index numbers as the parent. For example, if a volume set contains three volumes with sizes 1GB, 2GB and 3GB, and indexes 0, 1 and 2 respectively, then the snapshot volume set must have three volumes with the same sizes matched to the same set of index numbers. The corresponding volumes in the parent and snapshot volume sets are also subject to the same restrictions as apply between standalone volumes and their snapshots.

You can use the `vxvset list` command to verify that the volume sets have identical characteristics as shown in this example:

```
# vxvset -g mydg list vset1
```

VOLUME	INDEX	LENGTH	KSTATE	CONTEXT
vol_0	0	204800	ENABLED	-
vol_1	1	409600	ENABLED	-
vol_2	2	614400	ENABLED	-

```
# vxvset -g mydg list snapvset1
```

VOLUME	INDEX	LENGTH	KSTATE	CONTEXT
svol_0	0	204800	ENABLED	-
svol_1	1	409600	ENABLED	-
svol_2	2	614400	ENABLED	-

A full-sized instant snapshot of a volume set can be created using a prepared volume set in which each volume is the same size as the corresponding volume in the parent volume set. Alternatively, you can use the `nmirrors` attribute to specify the number of plexes that are to be broken off provided that sufficient plexes exist for each volume in the volume set.

The following example shows how to prepare a source volume set, `vset1`, and an identical volume set, `snapvset1`, which is then used to create the snapshot:

```
# vxsnap -g mydg prepare vset1
# vxsnap -g mydg prepare snapvset1
# vxsnap -g mydg make source=vset1/snapvol=snapvset1
```

To create a full-sized third-mirror break-off snapshot, you must ensure that each volume in the source volume set contains sufficient plexes. The following example shows how to achieve this by using the `vxsnap` command to add the required number of plexes before breaking off the snapshot:

```
# vxsnap -g mydg prepare vset2
# vxsnap -g mydg addmir vset2 nmirror=1
# vxsnap -g mydg make source=vset2/newvol=snapvset2/nmirror=1
```

See [“Adding snapshot mirrors to a volume”](#) on page 418.

To create a space-optimized instant snapshot of a volume set, the commands are again identical to those for a standalone volume as shown in these examples:

```
# vxsnap -g mydg prepare vset3
# vxsnap -g mydg make source=vset3/newvol=snapvset3/cachesize=20m

# vxsnap -g mydg prepare vset4
# vxsnap -g mydg make source=vset4/newvol=snapvset4/cache=mycobj
```

Here a new cache object is created for the volume set, `vset3`, and an existing cache object, `mycobj`, is used for `vset4`.

See [“About volume sets”](#) on page 447.

## Adding snapshot mirrors to a volume

If you are going to create a full-sized break-off snapshot volume, you can use the following command to add new snapshot mirrors to a volume:

```
# vxsnap [-b] [-g diskgroup] addmir volume|volume_set \
    [nmirror=N] [alloc=storage_attributes]
```

The volume must have been prepared using the `vxsnap prepare` command.

See [“Preparing a volume for DRL and instant snapshots”](#) on page 360.

If a volume set name is specified instead of a volume, the specified number of plexes is added to each volume in the volume set.

By default, the `vxsnap addmir` command adds one snapshot mirror to a volume unless you use the `nmirror` attribute to specify a different number of mirrors. The mirrors remain in the `SNAPATT` state until they are fully synchronized. The `-b` option can be used to perform the synchronization in the background. Once synchronized, the mirrors are placed in the `SNAPDONE` state.

For example, the following command adds 2 mirrors to the volume, `vol1`, on disks `mydg10` and `mydg11`:

```
# vxsnap -g mydg addmir vol1 nmirror=2 alloc=mydg10,mydg11
```

This command is similar in usage to the `vxassist snapstart` command, and supports the traditional third-mirror break-off snapshot model. As such, it does not provide an instant snapshot capability.

Once you have added one or more snapshot mirrors to a volume, you can use the `vxsnap make` command with either the `nmirror` attribute or the `plex` attribute to create the snapshot volumes.

## Removing a snapshot mirror

To remove a single snapshot mirror from a volume, use this command:

```
# vxsnap [-g diskgroup] rmmir volume|volume_set
```

For example, the following command removes a snapshot mirror from the volume, `voll`:

```
# vxsnap -g mydg rmmir voll
```

This command is similar in usage to the `vxassist snapabort` command.

If a volume set name is specified instead of a volume, a mirror is removed from each volume in the volume set.

## Removing a linked break-off snapshot volume

To remove a linked break-off snapshot volume from a volume, use this command:

```
# vxsnap [-g diskgroup] rmmir volume|volume_set mirvol=snapvol \  
[mirdg=snapdiskgroup]
```

The `mirvol` and optional `mirdg` attributes specify the snapshot volume, *snapvol*, and its disk group, *snapdiskgroup*. For example, the following command removes a linked snapshot volume, `prepsnap`, from the volume, `voll`:

```
# vxsnap -g mydg rmmir voll mirvol=prepsnap mirdg=mysnapdg
```

## Adding a snapshot to a cascaded snapshot hierarchy

To create a snapshot and push it onto a snapshot hierarchy between the original volume and an existing snapshot volume, specify the name of the existing snapshot volume as the value of the `infrontof` attribute to the `vxsnap make` command.

The following example shows how to place the space-optimized snapshot, `thurs_bu`, of the volume, `dbvol`, in front of the earlier snapshot, `wed_bu`:

```
# vxsnap -g dbdg make source=dbvol/newvol=thurs_bu/  
infrontof=wed_bu/cache=dbdgcache
```

Similarly, the next snapshot that is taken, `fri_bu`, is placed in front of `thurs_bu`:

```
# vxsnap -g dbdg make source=dbvol/newvol=fri_bu/  
infrontof=thurs_bu/cache=dbdgcache
```

See “[Cascaded snapshots](#)” on page 395.

## Refreshing an instant snapshot

Refreshing an instant snapshot replaces it with another point-in-time copy of a parent volume. To refresh one or more snapshots and make them immediately available for use, use the following command:

```
# vxsnap [-g diskgroup] refresh snapvolume|snapvolume_set \  
[source=volume|volume_set] [snapvol2 [source=vol2]...] \  
[syncing=yes|no]
```

If the source volume is not specified, the immediate parent of the snapshot is used. For full-sized instant snapshots, resynchronization is started by default. To disable resynchronization, specify the `syncing=no` attribute. This attribute is not supported for space-optimized snapshots.

---

**Warning:** The snapshot that is being refreshed must not be open to any application. For example, any file system configured on the volume must first be unmounted.

---

It is possible to refresh a volume from an unrelated volume provided that their sizes are compatible.

You can use the `vxsnap syncwait` command to wait for the synchronization of the snapshot volume to be completed, as shown here:

```
# vxsnap [-g diskgroup] syncwait snapvol
```

See “[Controlling instant snapshot synchronization](#)” on page 426.

## Reattaching an instant snapshot

---

**Note:** This operation is not supported for space-optimized instant snapshots.

---

Using the following command, some or all plexes of an instant snapshot may be reattached to the specified original volume, or to a source volume in the snapshot hierarchy above the snapshot volume:

```
# vxsnap [-g diskgroup] reattach snapvolume|snapvolume_set \  
source=volume|volume_set [nmirror=number]
```

By default, all the plexes are reattached, which results in the removal of the snapshot. If required, the number of plexes to be reattached may be specified as the value assigned to the `nmirror` attribute.

---

**Warning:** The snapshot that is being reattached must not be open to any application. For example, any file system configured on the snapshot volume must first be unmounted.

---

It is possible to reattach a volume to an unrelated volume provided that their volume sizes and region sizes are compatible.

For example the following command reattaches one plex from the snapshot volume, `snapmyvol`, to the volume, `myvol`:

```
# vxsnap -g mydg reattach snapmyvol source=myvol nmirror=1
```

While the reattached plexes are being resynchronized from the data in the parent volume, they remain in the `SNAPTMP` state. After resynchronization is complete, the plexes are placed in the `SNAPDONE` state. You can use the `vxsnap snapwait` command (but not `vxsnap syncwait`) to wait for the resynchronization of the reattached plexes to complete, as shown here:

```
# vxsnap -g mydg snapwait myvol nmirror=1
```

If the volume and its snapshot have both been resized (to an identical smaller or larger size) before performing the reattachment, a fast resynchronization can still be performed. A full resynchronization is not required. Version 20 DCO volumes are resized proportionately when the associated data volume is resized. For version 0 DCO volumes, the FastResync maps stay the same size, but the region size is recalculated, and the locations of the dirty bits in the existing maps are adjusted. In both cases, new regions are marked as dirty in the maps.

## Reattaching a linked break-off snapshot volume

Unlike other types of snapshot, the reattachment operation for linked break-off snapshot volumes does not return the plexes of the snapshot volume to the parent volume. The link relationship is re-established that makes the snapshot volume a mirror of the parent volume, and this allows the snapshot data to be resynchronized. However, the snapshot volume is only readopted by its parent volume if they are both in the same disk group.

To reattach a linked break-off snapshot volume, use the following form of the `vxsnap reattach` command:

```
# vxsnap [-g snapdiskgroup] reattach snapvolume|snapvolume_set \
  source=volume|volume_set [sourcedg=diskgroup]
```

The `sourcedg` attribute must be used to specify the data volume's disk group if this is different from the snapshot volume's disk group, *snapdiskgroup*.

---

**Warning:** The snapshot that is being reattached must not be open to any application. For example, any file system configured on the snapshot volume must first be unmounted.

---

It is possible to reattach a volume to an unrelated volume provided that their sizes and region sizes are compatible.

For example the following command reattaches the snapshot volume, `prepsnap`, in the disk group, `snapdg`, to the volume, `myvol`, in the disk group, `mydg`:

```
# vxsnap -g snapdg reattach prepsnap source=myvol sourcedg=mydg
```

After resynchronization of the snapshot volume is complete, the link is placed in the `ACTIVE` state. You can use the `vxsnap snapwait` command (but not `vxsnap syncwait`) to wait for the resynchronization of the reattached volume to complete, as shown here:

```
# vxsnap -g snapdg snapwait myvol mirvol=prepsnap
```

## Restoring a volume from an instant snapshot

It may sometimes be desirable to reinstate the contents of a volume from a backup or modified replica in a snapshot volume. The following command may be used to restore one or more volumes from the specified snapshots:

```
# vxsnap [-g diskgroup] restore volume|volume_set \
  source=snapvolume|snapvolume_set \
  [[volume2|volume_set2 \
  source=snapvolume2|snapvolume_set2...] \
  [destroy=yes|no] [syncing=yes|no] [nmirror=number]
```

For a full-sized instant snapshot, some or all of its plexes may be reattached to the parent volume or to a specified source volume in the snapshot hierarchy above the snapshot volume. If `destroy=yes` is specified, all the plexes of the full-sized instant snapshot are reattached and the snapshot volume is removed.

For a space-optimized instant snapshot, the cached data is used to recreate the contents of the specified volume. The space-optimized instant snapshot remains unchanged by the `restore` operation.

---

**Warning:** For this operation to succeed, the volume that is being restored and the snapshot volume must not be open to any application. For example, any file systems that are configured on either volume must first be unmounted.

---

It is not possible to restore a volume from an unrelated volume.

The `destroy` and `nmirror` attributes are not supported for space-optimized instant snapshots.

The following example demonstrates how to restore the volume, `myvol`, from the space-optimized snapshot, `snap3myvol`.

```
# vxsnap -g mydg restore myvol source=snap3myvol
```

## Dissociating an instant snapshot

The following command breaks the association between a full-sized instant snapshot volume, `snapvol`, and its parent volume, so that the snapshot may be used as an independent volume:

```
# vxsnap [-f] [-g diskgroup] dis snapvolume|snapvolume_set
```

This operation fails if the snapshot, `snapvol` has unsynchronized snapshots. If this happens, the dependent snapshots must be fully synchronized from `snapvol`. When no dependent snapshots remain, `snapvol` may be dissociated. The snapshot hierarchy is then adopted by the parent volume of `snapvol`.

See [“Controlling instant snapshot synchronization”](#) on page 426.

See [“Removing an instant snapshot”](#) on page 423.

The following command dissociates the snapshot, `snap2myvol`, from its parent volume:

```
# vxsnap -g mydg dis snap2myvol
```

---

**Warning:** When applied to a volume set or to a component volume of a volume set, this operation can result in inconsistencies in the snapshot hierarchy in the case of a system crash or hardware failure. If the operation is applied to a volume set, the `-f` (force) option must be specified.

---

## Removing an instant snapshot

When you have dissociated a full-sized instant snapshot, you can use the `vxedit` command to delete it altogether, as shown in this example:

```
# vxedit -g mydg -r rm snap2myvol
```

You can also use this command to remove a space-optimized instant snapshot from its cache.

See [“Removing a cache”](#) on page 430.

## Splitting an instant snapshot hierarchy

---

**Note:** This operation is not supported for space-optimized instant snapshots.

---

The following command breaks the association between a snapshot hierarchy that has the snapshot volume, *snapvol*, at its head, and its parent volume, so that the snapshot hierarchy may be used independently of the parent volume:

```
# vxsnap [-f] [-g diskgroup] split snapvolume|snapvolume_set
```

The topmost snapshot volume in the hierarchy must have been fully synchronized for this command to succeed. Snapshots that are lower down in the hierarchy need not have been fully resynchronized.

See [“Controlling instant snapshot synchronization”](#) on page 426.

The following command splits the snapshot hierarchy under `snap2myvol` from its parent volume:

```
# vxsnap -g mydg split snap2myvol
```

---

**Warning:** When applied to a volume set or to a component volume of a volume set, this operation can result in inconsistencies in the snapshot hierarchy in the case of a system crash or hardware failure. If the operation is applied to a volume set, the `-f` (force) option must be specified.

---

## Displaying instant snapshot information

The `vxsnap print` command may be used to display information about the snapshots that are associated with a volume.

```
# vxsnap [-g diskgroup] print [vol]
```

This command shows the percentage progress of the synchronization of a snapshot or volume. If no volume is specified, information about the snapshots for all the volumes in a disk group is displayed. The following example shows a volume,



`vol1`, which has a full-sized snapshot, `snapvol1` whose contents have not been synchronized with `vol1`:

```
# vxsnap -g mydg print
NAME          SNAPOBJECT      TYPE    PARENT  SNAPSHOT  %DIRTY  %VALID
vol1          --              volume  --      --        --      100
              snapvol1_snp1  volume  --      snapvol1  1.30    --
snapvol1     vol1_snp1       volume  vol1    --        1.30    1.30
```

The `%DIRTY` value for `snapvol1` shows that its contents have changed by 1.30% when compared with the contents of `vol1`. As `snapvol1` has not been synchronized with `vol1`, the `%VALID` value is the same as the `%DIRTY` value. If the snapshot were partly synchronized, the `%VALID` value would lie between the `%DIRTY` value and 100%. If the snapshot were fully synchronized, the `%VALID` value would be 100%. The snapshot could then be made independent or moved into another disk group.

Additional information about the snapshots of volumes and volume sets can be obtained by using the `-n` option with the `vxsnap print` command:

```
# vxsnap [-g diskgroup] -n [-l] [-v] [-x] print [vol]
```

Alternatively, you can use the `vxsnap list` command, which is an alias for the `vxsnap -n print` command:

```
# vxsnap [-g diskgroup] [-l] [-v] [-x] list [vol]
```

The following output is an example of using this command on the disk group `dg1`:

```
# vxsnap -g dg -vx list
```

NAME	DG	OBJTYPE	SNAPTYPE	PARENT	PARENTDG	SNAPDATE	CHANGE_DATA	SYNCED_DATA
vol	dg1	vol	-	-	-	-	-	10G (100%)
svol1	dg2	vol	fullinst	vol	dg1	2006/2/1 12:29	20M (0.2%)	60M (0.6%)
svol2	dg1	vol	mirbrk	vol	dg1	2006/2/1 12:29	120M (1.2%)	10G (100%)
svol3	dg2	vol	volbrk	vol	dg1	2006/2/1 12:29	105M (1.1%)	10G (100%)
svol21	dg1	vol	spaceopt	svol2	dg1	2006/2/1 12:29	52M (0.5%)	52M (0.5%)
vol-02	dg1	plex	snapmir	vol	dg1	-	-	56M (0.6%)
mvol	dg2	vol	mirvol	vol	dg1	-	-	58M (0.6%)
vset1	dg1	vset	-	-	-	-	-	2G (100%)
v1	dg1	compvol	-	-	-	-	-	1G (100%)
v2	dg1	compvol	-	-	-	-	-	1G (100%)
svset1	dg1	vset	mirbrk	vset	dg1	2006/2/1 12:29	1G (50%)	2G (100%)
sv1	dg1	compvol	mirbrk	v1	dg1	2006/2/1 12:29	512M (50%)	1G (100%)
sv2	dg1	compvol	mirbrk	v2	dg1	2006/2/1 12:29	512M (50%)	1G (100%)

```
vol-03 dg1 plex detmir vol dg1 - 20M (0.2%) -
mvol2 dg2 vol detvol vol dg1 - 20M (0.2%) -
```

This shows that the volume `vol` has three full-sized snapshots, `svol1`, `svol2` and `svol3`, which are of types full-sized instant (`fullinst`), mirror break-off (`mirbrk`) and linked break-off (`volbrk`). It also has one snapshot `plex` (`snapmir`), `vol-02`, and one linked mirror volume (`mirvol`), `mvol`. The snapshot `svol2` itself has a space-optimized instant snapshot (`spaceopt`), `svol21`. There is also a volume set, `vset1`, with component volumes `v1` and `v2`. This volume set has a mirror break-off snapshot, `svset1`, with component volumes `sv1` and `sv2`. The last two entries show a detached plex, `vol-03`, and a detached mirror volume, `mvol2`, which have `vol` as their parent volume. These snapshot objects may have become detached due to an I/O error, or, in the case of the plex, by running the `vxplex det` command.

The `CHANGE_DATA` column shows the approximate difference between the current contents of the snapshot and its parent volume. This corresponds to the amount of data that would have to be resynchronized to make the contents the same again.

The `SYNCED_DATA` column shows the approximate progress of synchronization since the snapshot was taken.

The `-l` option can be used to obtain a longer form of the output listing instead of the tabular form.

The `-x` option expands the output to include the component volumes of volume sets.

See the `vxsnap(1M)` manual page for more information about using the `vxsnap print` and `vxsnap list` commands.

## Controlling instant snapshot synchronization

Synchronization of the contents of a snapshot with its original volume is not possible for space-optimized instant snapshots.

By default, synchronization is enabled for the `vxsnap reattach`, `refresh` and `restore` operations on instant snapshots. Otherwise, synchronization is disabled unless you specify the `syncing=yes` attribute to the `vxsnap` command.

[Table 9-1](#) shows the commands that are provided for controlling the synchronization manually.

**Table 9-1** Commands for controlling instant snapshot synchronization

Command	Description
<code>vxsnap [-g <i>diskgroup</i>] syncpause \ vol vol_set</code>	Pause synchronization of a volume.
<code>vxsnap [-g <i>diskgroup</i>] syncresume \ vol vol_set</code>	Resume synchronization of a volume.
<code>vxsnap [-b] [-g <i>diskgroup</i>] syncstart \ vol vol_set</code>	Start synchronization of a volume. The <code>-b</code> option puts the operation in the background.
<code>vxsnap [-g <i>diskgroup</i>] syncstop \ vol vol_set</code>	Stop synchronization of a volume.
<code>vxsnap [-g <i>diskgroup</i>] syncwait \ vol vol_set</code>	Exit when synchronization of a volume is complete. An error is returned if the <code>vol</code> or <code>vol_set</code> is invalid (for example, it is a space-optimized snapshot), or if the <code>vol</code> or <code>vol_set</code> is not being synchronized.  <b>Note:</b> You cannot use this command to wait for synchronization of reattached plexes to complete.

The commands that are shown in [Table 9-1](#) cannot be used to control the synchronization of linked break-off snapshots.

The `vxsnap snapwait` command is provided to wait for the link between new linked break-off snapshots to become ACTIVE, or for reattached snapshot plexes to reach the SNAPDONE state following resynchronization.

See [“Creating and managing linked break-off snapshot volumes”](#) on page 413.

See [“Reattaching an instant snapshot”](#) on page 420.

See [“Reattaching a linked break-off snapshot volume”](#) on page 421.

## Improving the performance of snapshot synchronization

The following optional arguments to the `-o` option are provided to help optimize the performance of synchronization when using the `make`, `refresh`, `restore` and `syncstart` operations with full-sized instant snapshots:

<code>iosize=size</code>	Specifies the size of each I/O request that is used when synchronizing the regions of a volume. Specifying a larger size causes synchronization to complete sooner, but with greater impact on the performance of other processes that are accessing the volume. The default size of 1m (1MB) is suggested as the minimum value for high-performance array and controller hardware. The specified value is rounded to a multiple of the volume's region size.
<code>slow=iodelay</code>	Specifies the delay in milliseconds between synchronizing successive sets of regions as specified by the value of <code>iosize</code> . This can be used to change the impact of synchronization on system performance. The default value of <code>iodelay</code> is 0 milliseconds (no delay). Increasing this value slows down synchronization, and reduces the competition for I/O bandwidth with other processes that may be accessing the volume.

Options may be combined as shown in the following examples:

```
# vxsnap -g mydg -o iosize=2m,slow=100 make \  
source=myvol/snapvol=snap2myvol/syncing=on  
  
# vxsnap -g mydg -o iosize=10m,slow=250 syncstart snap2myvol
```

---

**Note:** The `iosize` and `slow` parameters are not supported for space-optimized snapshots.

---

## Listing the snapshots created on a cache

To list the space-optimized instant snapshots that have been created on a cache object, use the following command:

```
# vxcache [-g diskgroup] listvol cache_object
```

The snapshot names are printed as a space-separated list ordered by timestamp. If two or more snapshots have the same timestamp, these snapshots are sorted in order of decreasing size.

## Tuning the autogrow attributes of a cache

The `highwatermark`, `autogrowby` and `maxautogrow` attributes determine how the VxVM cache daemon (`vxcached`) maintains the cache if the `autogrow` feature has been enabled and `vxcached` is running:

- When cache usage reaches the high watermark value, `highwatermark` (default value is 90 percent), `vxcached` grows the size of the cache volume by the value of `autogrowby` (default value is 20% of the size of the cache volume in blocks). The new required cache size cannot exceed the value of `maxautogrow` (default value is twice the size of the cache volume in blocks).
- When cache usage reaches the high watermark value, and the new required cache size would exceed the value of `maxautogrow`, `vxcached` deletes the oldest snapshot in the cache. If there are several snapshots with the same age, the largest of these is deleted.

If the `autogrow` feature has been disabled:

- When cache usage reaches the high watermark value, `vxcached` deletes the oldest snapshot in the cache. If there are several snapshots with the same age, the largest of these is deleted. If there is only a single snapshot, this snapshot is detached and marked as invalid.

---

**Note:** The `vxcached` daemon does not remove snapshots that are currently open, and it does not remove the last or only snapshot in the cache.

---

If the cache space becomes exhausted, the snapshot is detached and marked as invalid. If this happens, the snapshot is unrecoverable and must be removed. Enabling the `autogrow` feature on the cache helps to avoid this situation occurring. However, for very small caches (of the order of a few megabytes), it is possible for the cache to become exhausted before the system has time to respond and grow the cache. In such cases, you can increase the size of the cache manually.

See “[Growing and shrinking a cache](#)” on page 430.

Alternatively, you can use the `vxcache set` command to reduce the value of `highwatermark` as shown in this example:

```
# vxcache -g mydg set highwatermark=60 cobjmydg
```

You can use the `maxautogrow` attribute to limit the maximum size to which a cache can grow. To estimate this size, consider how much the contents of each source volume are likely to change between snapshot refreshes, and allow some additional space for contingency.

If necessary, you can use the `vxcache set` command to change other `autogrow` attribute values for a cache.

See the `vxcache(1M)` manual page.

## Growing and shrinking a cache

You can use the `vxcache` command to increase the size of the cache volume that is associated with a cache object:

```
# vxcache [-g diskgroup] growcacheto cache_object size
```

For example, to increase the size of the cache volume associated with the cache object, `mycache`, to 2GB, you would use the following command:

```
# vxcache -g mydg growcacheto mycache 2g
```

To grow a cache by a specified amount, use the following form of the command shown here:

```
# vxcache [-g diskgroup] growcacheby cache_object size
```

For example, the following command increases the size of `mycache` by 1GB:

```
# vxcache -g mydg growcacheby mycache 1g
```

You can similarly use the `shrinkcacheby` and `shrinkcacheto` operations to reduce the size of a cache.

See the `vxcache(1M)` manual page.

## Removing a cache

To remove a cache completely, including the cache object, its cache volume and all space-optimized snapshots that use the cache:

- 1 Run the following command to find out the names of the top-level snapshot volumes that are configured on the cache object:

```
# vxprint -g diskgroup -vne \  
"v_plex.pl_subdisk.sd_dm_name ~ /cache_object/"
```

where `cache_object` is the name of the cache object.

- 2 Remove all the top-level snapshots and their dependent snapshots (this can be done with a single command):

```
# vxedit -g diskgroup -r rm snapvol ...
```

where `snapvol` is the name of a top-level snapshot volume.

**3** Stop the cache object:

```
# vxcache -g diskgroup stop cache_object
```

**4** Finally, remove the cache object and its cache volume:

```
# vxedit -g diskgroup -r rm cache_object
```

## Creating traditional third-mirror break-off snapshots

VxVM provides third-mirror break-off snapshot images of volume devices using `vxassist` and other commands.

To enhance the efficiency and usability of volume snapshots, turn on FastResync.

See [“Enabling FastResync on a volume”](#) on page 374.

If Persistent FastResync is required, you must associate a version 0 DCO with the volume.

See [“Adding a version 0 DCO and DCO volume”](#) on page 440.

A plex is required that is large enough to store the complete contents of the volume. Alternatively, you can use space-optimized instant snapshots.

See [“Creating and managing space-optimized instant snapshots”](#) on page 406.

The recommended approach to performing volume backup from the command line, or from a script, is to use the `vxsnap` command. The `vxassist snapstart`, `snapwait`, and `snapshot` commands are supported for backward compatibility.

The `vxassist snapshot` procedure consists of two steps:

- Run `vxassist snapstart` to create a snapshot mirror.
- Run `vxassist snapshot` to create a snapshot volume.

The `vxassist snapstart` step creates a write-only backup plex which gets attached to and synchronized with the volume. When synchronized with the volume, the backup plex is ready to be used as a `snapshot mirror`. The end of the update procedure is indicated by the new `snapshot mirror` changing its state to `SNAPDONE`. This change can be tracked by the `vxassist snapwait` task, which waits until at least one of the mirrors changes its state to `SNAPDONE`. If the attach process fails, the `snapshot mirror` is removed and its space is released.

---

**Note:** If the `snapstart` procedure is interrupted, the snapshot mirror is automatically removed when the volume is started.

---

Once the `snapshot mirror` is synchronized, it continues being updated until it is detached. You can then select a convenient time at which to create a `snapshot volume` as an image of the existing volume. You can also ask users to refrain from using the system during the brief time required to perform the `snapshot` (typically less than a minute). The amount of time involved in creating the `snapshot mirror` is long in contrast to the brief amount of time that it takes to create the `snapshot volume`.

The online backup procedure is completed by running the `vxassist snapshot` command on a volume with a `SNAPDONE` mirror. This task detaches the finished `snapshot` (which becomes a normal mirror), creates a new normal volume and attaches the `snapshot mirror` to the `snapshot volume`. The `snapshot` then becomes a normal, functioning volume and the state of the `snapshot` is set to `ACTIVE`.



## To back up a volume using the vxassist command

- 1 Create a snapshot mirror for a volume using the following command:

```
# vxassist [-b] [-g diskgroup] snapstart [nmirror=N] volume
```

For example, to create a snapshot mirror of a volume called `voldef`, use the following command:

```
# vxassist [-g diskgroup] snapstart voldef
```

The `vxassist snapstart` task creates a write-only mirror, which is attached to and synchronized from the volume to be backed up.

By default, VxVM attempts to avoid placing snapshot mirrors on a disk that already holds any plexes of a data volume. However, this may be impossible if insufficient space is available in the disk group. In this case, VxVM uses any available space on other disks in the disk group. If the snapshot plexes are placed on disks which are used to hold the plexes of other volumes, this may cause problems when you subsequently attempt to move a snapshot volume into another disk group.

See [“Moving DCO volumes between disk groups”](#) on page 261.

To override the default storage allocation policy, you can use storage attributes to specify explicitly which disks to use for the snapshot plexes.

See [“Creating a volume on specific disks”](#) on page 313.

If you start `vxassist snapstart` in the background using the `-b` option, you can use the `vxassist snapwait` command to wait for the creation of the mirror to complete as shown here:

```
# vxassist [-g diskgroup] snapwait volume
```

If `vxassist snapstart` is not run in the background, it does not exit until the mirror has been synchronized with the volume. The mirror is then ready to be used as a plex of a snapshot volume. While attached to the original volume, its contents continue to be updated until you take the snapshot.

Use the `nmirror` attribute to create as many snapshot mirrors as you need for the snapshot volume. For a backup, you should usually only require the default of one.

It is also possible to make a snapshot plex from an existing plex in a volume.

See [“Converting a plex into a snapshot plex”](#) on page 435.

- 2 Choose a suitable time to create a snapshot. If possible, plan to take the snapshot at a time when users are accessing the volume as little as possible.

**3** Create a snapshot volume using the following command:

```
# vxassist [-g diskgroup] snapshot [nmirror=N] volume snapshot
```

If required, use the `nmirror` attribute to specify the number of mirrors in the snapshot volume.

For example, to create a snapshot of `voldef`, use the following command:

```
# vxassist -g mydg snapshot voldef snapvoldef
```

The `vxassist snapshot` task detaches the finished snapshot mirror, creates a new volume, and attaches the snapshot mirror to it. This step should only take a few minutes. The snapshot volume, which reflects the original volume at the time of the snapshot, is now available for backing up, while the original volume continues to be available for applications and users.

If required, you can make snapshot volumes for several volumes in a disk group at the same time.

See [“Creating multiple snapshots with the vxassist command”](#) on page 436.

**4** Use `fsck` (or some utility appropriate for the application running on the volume) to clean the temporary volume’s contents. For example, you can use this command with a VxFS file system:

```
# fsck -F vxfs /dev/vx/rdisk/diskgroup/snapshot
```

The specified device must have a valid entry in the `/etc/vfstab` file.

**5** If you require a backup of the data in the snapshot, use an appropriate utility or operating system command to copy the contents of the snapshot to tape, or to some other backup medium.

**6** When the backup is complete, you have the following choices for what to do with the snapshot volume:

- Reattach some or all of the plexes of the snapshot volume with the original volume.  
See [“Reattaching a snapshot volume”](#) on page 437.
- If `FastResync` was enabled on the volume before the snapshot was taken, this speeds resynchronization of the snapshot plexes before the backup cycle starts again at step 3.
- Dissociate the snapshot volume entirely from the original volume  
See [“Dissociating a snapshot volume”](#) on page 439.
- This may be useful if you want to use the copy for other purposes such as testing or report generation.

- Remove the snapshot volume to save space with this command:

```
# vxedit [-g diskgroup] -rf rm snapshot
```

Dissociating or removing the snapshot volume loses the advantage of fast resynchronization if FastResync was enabled. If there are no further snapshot plexes available, any subsequent snapshots that you take require another complete copy of the original volume to be made.

## Converting a plex into a snapshot plex

---

**Note:** A plex cannot be converted into a snapshot plex for layered volumes or for any volume that has an associated version 20 DCO volume.

---

It is recommended that the instant snapshot feature is used in preference to converting a plex into a snapshot plex.

In some circumstances, you may find it more convenient to convert an existing plex in a volume into a snapshot plex rather than running `vxassist snapstart`. For example, you may want to do this if you are short of disk space for creating the snapshot plex and the volume that you want to snapshot contains more than two plexes.

The procedure can also be used to speed up the creation of a snapshot volume when a mirrored volume is created with more than two plexes and `init=active` is specified.

It is advisable to retain at least two plexes in a volume to maintain data redundancy.

To convert an existing plex into a snapshot plex for a volume on which Persistent FastResync is enabled, use the following command:

```
# vxplex [-g diskgroup] -o dcomplex=dcologplex convert \  
state=SNAPDONE plex
```

*dcologplex* is the name of an existing DCO plex that is to be associated with the new snapshot plex. You can use the `vxprint` command to find out the name of the DCO volume.

See [“Adding a version 0 DCO and DCO volume”](#) on page 440.

For example, to make a snapshot plex from the plex `triv01-03` in the 3-plex volume `triv01`, you would use the following command:

```
# vxplex -o dcoplex=trivol_dco-03 convert state=SNAPDONE \  
trivol-03
```

Here the DCO plex `trivol_dco_03` is specified as the DCO plex for the new snapshot plex.

To convert an existing plex into a snapshot plex in the SNAPDONE state for a volume on which Non-Persistent FastResync is enabled, use the following command:

```
# vxplex [-g diskgroup] convert state=SNAPDONE plex
```

A converted plex is in the SNAPDONE state, and can be used immediately to create a snapshot volume.

---

**Note:** The last complete regular plex in a volume, an incomplete regular plex, or a dirty region logging (DRL) log plex cannot be converted into a snapshot plex.

---

## Creating multiple snapshots with the vxassist command

To make it easier to create snapshots of several volumes at the same time, the snapshot option accepts more than one volume name as its argument, for example:

```
# vxassist [-g diskgroup] snapshot volume1 volume2 ...
```

By default, the first snapshot volume is named *SNAP-volume*, and each subsequent snapshot is named *SNAPnumber-volume*, where *number* is a unique serial number, and *volume* is the name of the volume for which the snapshot is being taken. This default pattern can be overridden by using the option `-o name=pattern`, as described on the `vxassist(1M)` manual page. For example, the pattern `SNAP%v-%d` reverses the order of the *number* and *volume* components in the name.

To snapshot all the volumes in a single disk group, specify the option `-o allvols` to `vxassist`:

```
# vxassist -g diskgroup -o allvols snapshot
```

This operation requires that all `snapstart` operations are complete on the volumes. It fails if any of the volumes in the disk group do not have a complete snapshot plex in the SNAPDONE state.

---

**Note:** The `vxsnap` command provides similar functionality for creating multiple snapshots.

---

## Reattaching a snapshot volume

The snapback operation merges a snapshot copy of a volume with the original volume. One or more snapshot plexes are detached from the snapshot volume and re-attached to the original volume. The snapshot volume is removed if all its snapshot plexes are snapped back. This task resynchronizes the data in the volume so that the plexes are consistent.

The snapback operation cannot be applied to RAID-5 volumes unless they have been converted to a special layered volume layout by the addition of a DCO and DCO volume.

See [“Adding a version 0 DCO and DCO volume”](#) on page 440.

To enhance the efficiency of the snapback operation, enable FastResync on the volume before taking the snapshot

See [“Enabling FastResync on a volume”](#) on page 374.

To merge one snapshot plex with the original volume, use the following command:

```
# vxassist [-g diskgroup] snapback snapshot
```

where *snapshot* is the snapshot copy of the volume.

To merge all snapshot plexes in the snapshot volume with the original volume, use the following command:

```
# vxassist [-g diskgroup] -o allplexes snapback snapshot
```

To merge a specified number of plexes from the snapshot volume with the original volume, use the following command:

```
# vxassist [-g diskgroup] snapback nmirror=number snapshot
```

Here the `nmirror` attribute specifies the number of mirrors in the snapshot volume that are to be re-attached.

Once the snapshot plexes have been reattached and their data resynchronized, they are ready to be used in another `snapshot` operation.

By default, the data in the original volume is used to update the snapshot plexes that have been re-attached. To copy the data from the replica volume instead, use the following command:

```
# vxassist [-g diskgroup] -o resyncfromreplica snapback snapshot
```

---

**Warning:** Always unmount the snapshot volume (if this is mounted) before performing a snapback. In addition, you must unmount the file system corresponding to the primary volume before using the `resyncfromreplica` option.

---

## Adding plexes to a snapshot volume

If you want to retain the existing plexes in a snapshot volume after a snapback operation, you can create additional snapshot plexes that are to be used for the snapback.

### To add plexes to a snapshot volume

- 1 Use the following `vxprint` commands to discover the names of the snapshot volume's data change object (DCO) and DCO volume:

```
# DCONAME=`vxprint [-g diskgroup] -F%dco_name snapshot`  
# DCOVOL=`vxprint [-g diskgroup] -F%log_vol $DCONAME`
```

- 2 Use the `vxassist mirror` command to create mirrors of the existing snapshot volume and its DCO volume:

```
# vxassist -g diskgroup mirror snapshot  
# vxassist -g diskgroup mirror $DCOVOL
```

The new plex in the DCO volume is required for use with the new data plex in the snapshot.

- 3 Use the `vxprint` command to find out the name of the additional snapshot plex:

```
# vxprint -g diskgroup snapshot
```

- 4 Use the `vxprint` command to find out the record ID of the additional DCO plex:

```
# vxprint -g diskgroup -F%rid $DCOVOL
```

- 5 Use the `vxedit` command to set the `dco_plex_riid` field of the new data plex to the name of the new DCO plex:

```
# vxedit -g diskgroup set dco_plex_riid=dco_plex_riid new_plex
```

The new data plex is now ready to be used to perform a snapback operation.

## Dissociating a snapshot volume

The link between a snapshot and its original volume can be permanently broken so that the snapshot volume becomes an independent volume. Use the following command to dissociate the snapshot volume, *snapshot*:

```
# vxassist snapclear snapshot
```

## Displaying snapshot information

The `vxassist snapprint` command displays the associations between the original volumes and their respective replicas (snapshot copies):

```
# vxassist snapprint [volume]
```

Output from this command is shown in the following examples:

```
# vxassist -g mydg snapprint v1
```

V	NAME	USETYPE	LENGTH	
SS	SNAPOBJ	NAME	LENGTH	%DIRTY
DP	NAME	VOLUME	LENGTH	%DIRTY
v	v1	fsgen	20480	
ss	SNAP-v1_snp	SNAP-v1	20480	4
dp	v1-01	v1	20480	0
dp	v1-02	v1	20480	0
v	SNAP-v1	fsgen	20480	
ss	v1_snp	v1	20480	0

```
# vxassist -g mydg snapprint v2
```

V	NAME	USETYPE	LENGTH	
SS	SNAPOBJ	NAME	LENGTH	%DIRTY
DP	NAME	VOLUME	LENGTH	%DIRTY
v	v2	fsgen	20480	
ss	--	SNAP-v2	20480	0
dp	v2-01	v2	20480	0
v	SNAP-v2	fsgen	20480	
ss	--	v2	20480	0

In this example, Persistent FastResync is enabled on volume `v1`, and Non-Persistent FastResync on volume `v2`. Lines beginning with `v`, `dp` and `ss` indicate a volume, detached plex and snapshot plex respectively. The `%DIRTY` field indicates the percentage of a snapshot plex or detached plex that is dirty with respect to the original volume. Notice that no snap objects are associated with volume `v2` or with its snapshot volume `SNAP-v2`.

See [“How persistent FastResync works with snapshots”](#) on page 68.

If a volume is specified, the `snapprint` command displays an error message if no FastResync maps are enabled for that volume.

## Adding a version 0 DCO and DCO volume

The version 0 DCO log volume was introduced in VxVM 3.2. The version 0 layout supports traditional (third-mirror break-off) snapshots, but not full-sized or space-optimized instant snapshots.

See [“Version 0 DCO volume layout”](#) on page 67.

See [“Version 20 DCO volume layout”](#) on page 67.

See [“Determining the DCO version number”](#) on page 363.

To put Persistent FastResync into effect for a volume, a Data Change Object (DCO) and DCO volume must first be associated with that volume. When you have added a DCO object and DCO volume to a volume, you can then enable Persistent FastResync on the volume

See [“Enabling FastResync on a volume”](#) on page 374.

---

**Note:** You need a FastResync license key to use the FastResync feature. Even if you do not have a license, you can configure a DCO object and DCO volume so that snap objects are associated with the original and snapshot volumes.

---

See [“How persistent FastResync works with snapshots”](#) on page 68.



**To add a DCO object and DCO volume to an existing volume**

- 1 Ensure that the disk group containing the existing volume has been upgraded to at least version 90. Use the following command to check the version of a disk group:

```
# vxdg list diskgroup
```

To upgrade a disk group to the latest version, use the following command:

```
# vxdg upgrade diskgroup
```

See [“Upgrading a disk group”](#) on page 270.

- 2 Use the following command to turn off Non-Persistent FastResync on the original volume if it is currently enabled:

```
# vxvol [-g diskgroup] set fastresync=off volume
```

If you are uncertain about which volumes have Non-Persistent FastResync enabled, use the following command to obtain a listing of such volumes.

---

**Note:** The ! character is a special character in some shells. The following example shows how to escape it in a bash shell.

---

```
# vxprint [-g diskgroup] -F "%name" \  
-e "v_fastresync=on && \!v_hasdcolog"
```

Use the following command to add a DCO and DCO volume to the existing volume (which may already have dirty region logging (DRL) enabled):

```
# vxassist [-g diskgroup] addlog volume logtype=dc0 \  
[ndcomirror=number] [dcolen=size] [storage_attributes]
```

For non-layered volumes, the default number of plexes in the mirrored DCO volume is equal to the lesser of the number of plexes in the data volume or 2. For layered volumes, the default number of DCO plexes is always 2. If required, use the `ndcomirror` attribute to specify a different number. It is recommended that you configure as many DCO plexes as there are existing data and snapshot plexes in the volume. For example, specify `ndcomirror=3` when adding a DCO to a 3-way mirrored volume.

The default size of each plex is 132 blocks. You can use the `dcolen` attribute to specify a different *size*. If specified, the size of the plex must be an integer multiple of 33 blocks from 33 up to a maximum of 2112 blocks.

You can specify `vxassist`-style storage attributes to define the disks that can and/or cannot be used for the plexes of the DCO volume.

See [“Specifying storage for version 0 DCO plexes”](#) on page 442.

## Specifying storage for version 0 DCO plexes

If the disks that contain volumes and their snapshots are to be moved or split into different disk groups, the disks that contain their respective DCO plexes must be able to accompany them. By default, VxVM attempts to place version 0 DCO plexes on the same disks as the data plexes of the parent volume. However, this may be impossible if there is insufficient space available on those disks. In this case, VxVM uses any available space on other disks in the disk group. If the DCO plexes are

placed on disks which are used to hold the plexes of other volumes, this may cause problems when you subsequently attempt to move volumes into other disk groups.

You can use storage attributes to specify explicitly which disks to use for the DCO plexes. If possible, specify the same disks as those on which the volume is configured.

For example, to add a DCO object and DCO volume with plexes on `mydg05` and `mydg06`, and a plex size of 264 blocks to the volume, `myvol`, in the disk group, `mydg`, use the following command:

```
# vxassist -g mydg addlog myvol logtype=dco dcolen=264 mydg05 mydg06
```

To view the details of the DCO object and DCO volume that are associated with a volume, use the `vxprint` command. The following is partial `vxprint` output for the volume named `vol1` (the `TUTIL0` and `PUTIL0` columns are omitted for clarity):

TY	NAME	ASSOC	KSTATE	LENGTH	PLOFFS	STATE	...
v	vol1	fsgen	ENABLED	1024	-	ACTIVE	
pl	vol1-01	vol1	ENABLED	1024	-	ACTIVE	
sd	disk01-01	vol1-01	ENABLED	1024	0	-	
pl	vol1-02	vol1	ENABLED	1024	-	ACTIVE	
sd	disk02-01	vol1-02	ENABLED	1024	0	-	
dc	vol1_dco	vol1	-	-	-	-	
v	vol1_dcl	gen	ENABLED	132	-	ACTIVE	
pl	vol1_dcl-01	vol1_dcl	ENABLED	132	-	ACTIVE	
sd	disk03-01	vol1_dcl-01	ENABLED	132	0	-	
pl	vol1_dcl-02	vol1_dcl	ENABLED	132	-	ACTIVE	
sd	disk04-01	vol1_dcl-02	ENABLED	132	0	-	

In this output, the DCO object is shown as `vol1_dco`, and the DCO volume as `vol1_dcl` with 2 plexes, `vol1_dcl-01` and `vol1_dcl-02`.

If required, you can use the `vxassist move` command to relocate DCO plexes to different disks. For example, the following command moves the plexes of the DCO volume, `vol1_dcl`, for volume `vol1` from `disk03` and `disk04` to `disk07` and `disk08`.

---

**Note:** The `!` character is a special character in some shells. The following example shows how to escape it in a bash shell.

---

```
# vxassist -g mydg move vol1_dcl \!disk03 \!disk04 disk07 disk08
```

See [“Moving DCO volumes between disk groups”](#) on page 261.

See the `vxassist(1M)` manual page.

## Removing a version 0 DCO and DCO volume

To dissociate a version 0 DCO object, DCO volume and any snap objects from a volume, use the following command:

```
# vxassist [-g diskgroup] remove log volume logtype=dcv
```

This completely removes the DCO object, DCO volume and any snap objects. It also has the effect of disabling FastResync for the volume.

Alternatively, you can use the `vxdco` command to the same effect:

```
# vxdco [-g diskgroup] [-o rm] dis dco_obj
```

The default name of the DCO object, `dco_obj`, for a volume is usually formed by appending the string `_dco` to the name of the parent volume. To find out the name of the associated DCO object, use the `vxprint` command on the volume.

To dissociate, but not remove, the DCO object, DCO volume and any snap objects from the volume, `myvol`, in the disk group, `mydg`, use the following command:

```
# vxdco -g mydg dis myvol_dco
```

This form of the command dissociates the DCO object from the volume but does not destroy it or the DCO volume. If the `-o rm` option is specified, the DCO object, DCO volume and its plexes, and any snap objects are also removed.

---

**Warning:** Dissociating a DCO and DCO volume disables Persistent FastResync on the volume. A full resynchronization of any remaining snapshots is required when they are snapped back.

---

See the `vxassist(1M)` manual page.

See the `vxdco(1M)` manual pages.

## Reattaching a version 0 DCO and DCO volume

If a version 0 DCO object and DCO volume are not removed by specifying the `-o rm` option to `vxdco`, they can be reattached to the parent volume using the following command:

```
# vxdco [-g diskgroup] att volume dco_obj
```

For example, to reattach the DCO object, `myvol_dco`, to the volume, `myvol`, use the following command:

```
# vxdco -g mydg att myvol myvol_dco
```

See the `vxdcc(1M)` manual page.



# Creating and administering volume sets

This chapter includes the following topics:

- [About volume sets](#)
- [Creating a volume set](#)
- [Adding a volume to a volume set](#)
- [Removing a volume from a volume set](#)
- [Listing details of volume sets](#)
- [Stopping and starting volume sets](#)
- [Raw device node access to component volumes](#)

## About volume sets

Veritas File System (VxFS) uses volume sets to implement its Multi-Volume Support and Dynamic Storage Tiering (DST) features. For more information on DST, see the *Veritas File System Administrator's Guide*.

Veritas Volume Manager (VxVM) provides the `vxvset` command to create and administer volume sets.

See the `vxvset(1M)` manual page.

Volume sets have the following limitations:

- A maximum of 2048 volumes can be configured in a volume set.
- Only a Veritas File System is supported on a volume set.

- The first volume (index 0) in a volume set must be larger than the sum of the total volume size divided by 4000, the size of the VxFS intent log, and 1MB. Volumes 258 MB or larger should always suffice.
- Raw I/O from and to a volume set is not supported.
- Raw I/O from and to the component volumes of a volume set is supported under certain conditions.  
See [“Raw device node access to component volumes”](#) on page 451.
- Volume sets can be used in place of volumes with the following `vxsnap` operations on instant snapshots: `addmir`, `dis`, `make`, `prepare`, `reattach`, `refresh`, `restore`, `rmmir`, `split`, `syncpause`, `syncresume`, `syncstart`, `syncstop`, `syncwait`, and `unprepare`. The third-mirror break-off usage model for full-sized instant snapshots is supported for volume sets provided that sufficient plexes exist for each volume in the volume set.  
See [“Creating instant snapshots of volume sets”](#) on page 416.
- A full-sized snapshot of a volume set must itself be a volume set with the same number of volumes and the same volume index numbers as the parent. The corresponding volumes in the parent and snapshot volume sets are also subject to the same restrictions as apply between standalone volumes and their snapshots.

## Creating a volume set

To create a volume set for use by Veritas File System (VxFS), use the following command:

```
# vxvset [-g diskgroup] -t vxfs make volset volume
```

Here *volset* is the name of the volume set, and *volume* is the name of the first volume in the volume set. The `-t vxfs` option creates the volume set configured for use by VxFS. You must create the volume before running the command. `vxvset` will not automatically create the volume.

For example, to create a volume set named `myvset` that contains the volume `vol1`, in the disk group `mydg`, you would use the following command:

```
# vxvset -g mydg -t vxfs make myvset vol1
```

## Adding a volume to a volume set

Having created a volume set containing a single volume, you can use the following command to add further volumes to the volume set:



```
# vxvset [-g diskgroup] [-f] addvol volset volume
```

For example, to add the volume `vol2`, to the volume set `myvset`, use the following command:

```
# vxvset -g mydg addvol myvset vol2
```

---

**Warning:** The `-f` (force) option must be specified if the volume being added, or any volume in the volume set, is either a snapshot or the parent of a snapshot. Using this option can potentially cause inconsistencies in a snapshot hierarchy if any of the volumes involved in the operation is already in a snapshot chain.

---

## Removing a volume from a volume set

To remove a component volume from a volume set, use the following command:

```
# vxvset [-g diskgroup] [-f] rmvol volset volume
```

For example, the following commands remove the volumes, `vol1` and `vol2`, from the volume set `myvset`:

```
# vxvset -g mydg rmvol myvset vol1  
# vxvset -g mydg rmvol myvset vol2
```

Removing the final volume deletes the volume set.

---

**Warning:** The `-f` (force) option must be specified if the volume being removed, or any volume in the volume set, is either a snapshot or the parent of a snapshot. Using this option can potentially cause inconsistencies in a snapshot hierarchy if any of the volumes involved in the operation is already in a snapshot chain.

---

## Listing details of volume sets

To list the details of the component volumes of a volume set, use the following command:

```
# vxvset [-g diskgroup] list [volset]
```

If the name of a volume set is not specified, the command lists the details of all volume sets in a disk group, as shown in the following example:

```
# vxvset -g mydg list
```

NAME	GROUP	NVOLS	CONTEXT
set1	mydg	3	-
set2	mydg	2	-

To list the details of each volume in a volume set, specify the name of the volume set as an argument to the command:

```
# vxvset -g mydg list set1
```

VOLUME	INDEX	LENGTH	KSTATE	CONTEXT
vol1	0	12582912	ENABLED	-
vol2	1	12582912	ENABLED	-
vol3	2	12582912	ENABLED	-

The context field contains details of any string that the application has set up for the volume or volume set to tag its purpose.

## Stopping and starting volume sets

Under some circumstances, you may need to stop and restart a volume set. For example, a volume within the set may have become detached, as shown here:

```
# vxvset -g mydg list set1
```

VOLUME	INDEX	LENGTH	KSTATE	CONTEXT
vol1	0	12582912	DETACHED	-
vol2	1	12582912	ENABLED	-
vol3	2	12582912	ENABLED	-

To stop and restart one or more volume sets, use the following commands:

```
# vxvset [-g diskgroup] stop volset ...
# vxvset [-g diskgroup] start volset ...
```

For the example given previously, the effect of running these commands on the component volumes is shown below:

```
# vxvset -g mydg stop set1
```

```
# vxvset -g mydg list set1
```

VOLUME	INDEX	LENGTH	KSTATE	CONTEXT
vol1	0	12582912	DISABLED	-
vol2	1	12582912	DISABLED	-

```

vol3                2                12582912            DISABLED            -

# vxvset -g mydg start set1

# vxvset -g mydg list set1

VOLUME             INDEX             LENGTH             KSTATE             CONTEXT
vol1                0                12582912            ENABLED            -
vol2                1                12582912            ENABLED            -
vol3                2                12582912            ENABLED            -

```

## Raw device node access to component volumes

To guard against accidental file system and data corruption, the device nodes of the component volumes are configured by default not to have raw and block entries in the `/dev/vx/rdisk/diskgroup` and `/dev/vx/dsk/diskgroup` directories. As a result, applications are prevented from directly reading from or writing to the component volumes of a volume set.

If some applications, such as the raw volume backup and restore feature of the Symantec NetBackup™ software, need to read from or write to the component volumes by accessing raw device nodes in the `/dev/vx/rdisk/diskgroup` directory, this is supported by specifying additional command-line options to the `vxvset` command. Access to the block device nodes of the component volumes of a volume set is unsupported.

---

**Warning:** Writing directly to or reading from the raw device node of a component volume of a volume set should only be performed if it is known that the volume's data will not otherwise change during the period of access.

---

All of the raw device nodes for the component volumes of a volume set can be created or removed in a single operation. Raw device nodes for any volumes added to a volume set are created automatically as required, and inherit the access mode of the existing device nodes.

Access to the raw device nodes for the component volumes can be configured to be read-only or read-write. This mode is shared by all the raw device nodes for the component volumes of a volume set. The read-only access mode implies that any writes to the raw device will fail, however writes using the `ioctl` interface or by VxFS to update metadata are not prevented. The read-write access mode allows direct writes via the raw device. The access mode to the raw device nodes of a volume set can be changed as required.

The presence of raw device nodes and their access mode is persistent across system reboots.

Note the following limitations of this feature:

- The disk group version must be 140 or greater.
- Access to the raw device nodes of the component volumes of a volume set is only supported for private disk groups; it is not supported for shared disk groups in a cluster.

## Enabling raw device access when creating a volume set

To enable raw device access when creating a volume set, use the following form of the `vxvset make` command:

```
# vxvset [-g diskgroup] -o makedev=on \  
  [-o compvol_access={read-only|read-write}] \  
  [-o index] [-c "ch_addopt"] make vset vol [index]
```

The `-o makedev=on` option enables the creation of raw device nodes for the component volumes at the same time that the volume set is created. The default setting is `off`.

If the `-o compvol_access=read-write` option is specified, direct writes are allowed to the raw device of each component volume. If the value is set to `read-only`, only reads are allowed from the raw device of each component volume.

If the `-o makedev=on` option is specified, but `-o compvol_access` is not specified, the default access mode is `read-only`.

If the `vxvset addvol` command is subsequently used to add a volume to a volume set, a new raw device node is created in `/dev/vx/rdisk/diskgroup` if the value of the `makedev` attribute is currently set to `on`. The access mode is determined by the current setting of the `compvol_access` attribute.

The following example creates a volume set, `myvset1`, containing the volume, `myvol1`, in the disk group, `mydg`, with raw device access enabled in read-write mode:

```
# vxvset -g mydg -o makedev=on -o compvol_access=read-write \  
  make myvset1 myvol1
```

## Displaying the raw device access settings for a volume set

You can use the `vxprint -m` command to display the current settings for a volume set. If the `makedev` attribute is set to `on`, one of the following strings is displayed in the output:

```
vset_devinfo=on:read-only      Raw device nodes in read-only mode.  
vset_devinfo=on:read-write    Raw device nodes in read-write mode.
```

A string is not displayed if `makedev` is set to `off`.

If the output from the `vxprint -m` command is fed to the `vxmake` command to recreate a volume set, the `vset_devinfo` attribute must set to `off`. Use the `vxvset` set command to re-enable raw device access with the desired access mode.

See “[Controlling raw device access for an existing volume set](#)” on page 453.

## Controlling raw device access for an existing volume set

To enable or disable raw device node access for an existing volume set, use the following command:

```
# vxvset [-g diskgroup] [-f] set makedev={on|off} vset
```

The `makedev` attribute can be specified to the `vxvset set` command to create (`makedev=on`) or remove (`makedev=off`) the raw device nodes for the component volumes of a volume set. If any of the component volumes are open, the `-f` (force) option must be specified to set the attribute to `off`.

Specifying `makedev=off` removes the existing raw device nodes from the `/dev/vx/rdisk/diskgroup` directory.

If the `makedev` attribute is set to `off`, and you use the `mknod` command to create the raw device nodes, you cannot read from or write to those nodes unless you set the value of `makedev` to `on`.

The syntax for setting the `compvol_access` attribute on a volume set is:

```
# vxvset [-g diskgroup] [-f] set \  
  compvol_access={read-only|read-write} vset
```

The `compvol_access` attribute can be specified to the `vxvset set` command to change the access mode to the component volumes of a volume set. If any of the component volumes are open, the `-f` (force) option must be specified to set the attribute to `read-only`.

The following example sets the `makedev=on` and `compvol_access=read-only` attributes on a volume set, `myvset2`, in the disk group, `mydg`:

```
# vxvset -g mydg set makedev=on myvset2
```

The next example sets the `compvol_access=read-write` attribute on the volume set, `myvset2`:

```
# vxvset -g mydg set compvol_access=read-write myvset2
```

The final example removes raw device node access for the volume set, `myvset2`:

```
# vxvset -g mydg set makedev=off myvset2
```

# Configuring off-host processing

This chapter includes the following topics:

- [About off-host processing solutions](#)
- [Implementation of off-host processing solutions](#)

## About off-host processing solutions

Off-host processing lets you implement the following activities:

Data backup	As the requirement for 24 x 7 availability becomes essential for many businesses, organizations cannot afford the downtime involved in backing up critical data offline. By taking a snapshot of the data, and backing up from this snapshot, business-critical applications can continue to run without extended down time or impacted performance.
Decision support analysis and reporting	Because snapshots hold a point-in-time copy of a production database, you can set up a replica of the database using the snapshots. Operations such as decision support analysis and business reporting do not require access to up-to-the-minute information. They can use a database copy that is running on a host other than the primary. When required, the database copy can quickly be synchronized with the data in the primary database.
Testing and training	Development or service groups can use snapshots as test data for new applications. Snapshot data gives developers, system testers and QA groups a realistic basis for testing the robustness, integrity, and performance of new applications.

**Database error recovery**      Logic errors caused by an administrator or an application program can compromise the integrity of a database. By restoring the database table files from a snapshot copy, the database can be recovered more quickly than by full restoration from tape or other backup media.

Using linked break-off snapshots makes off-host processing simpler.

See [“Linked break-off snapshot volumes”](#) on page 393.

## Implementation of off-host processing solutions

[Figure 11-1](#) shows an example implementation of off-host processing.

**Figure 11-1**      Example implementation of off-host processing

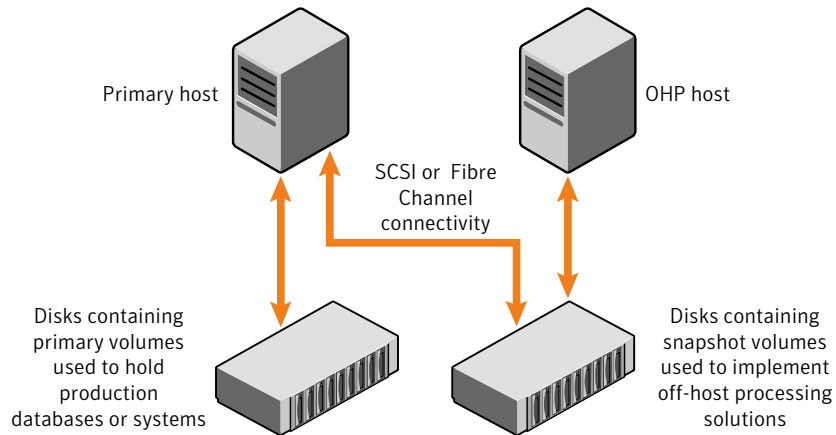

By accessing snapshot volumes from a lightly-loaded host (shown here as the off-host processing (OHP) host), CPU- and I/O-intensive operations for online backup and decision support do not degrade the performance of the primary host that is performing the main production activity (such as running a database). If you also place the snapshot volumes on disks that are attached to different host controllers than the disks in the primary volumes, it is possible to avoid contending with the primary host for I/O resources.

The following sections describe how you can apply off-host processing to implement regular online backup of a volume in a private disk group, and to set up a replica of a production database for decision support. The following applications are outlined:

See [“Implementing off-host online backup”](#) on page 457.

See [“Implementing decision support”](#) on page 461.



These applications use the Persistent FastResync feature of VxVM in conjunction with linked break-off snapshots.

A volume snapshot represents the data that exists in a volume at a given time. As such, VxVM does not have any knowledge of data that is cached by the overlying file system, or by applications such as databases that have files open in the file system. If you set the `fsgen` volume usage type on a volume that contains a Veritas File System (VxFS), intent logging of the file system metadata ensures the internal consistency of the file system that is backed up. For other file system types, depending on the intent logging capabilities of the file system, there may be potential be inconsistencies between in-memory data and the data in the snapshot image.

For databases, you must also use a suitable mechanism to ensure the integrity of tablespace data when the volume snapshot is taken. Most modern database software provides the facility to temporarily suspend file system I/O. For ordinary files in a file system, which may be open to a wide variety of different applications, there may be no way to ensure the complete integrity of the file data other than by shutting down the applications and temporarily unmounting the file system. In many cases, it may only be important to ensure the integrity of file data that is not in active use when you take the snapshot.

## Implementing off-host online backup

This section describes a procedure for implementing off-host online backup for a volume in a private disk group. It outlines how to set up a regular backup cycle. It is beyond the scope of this guide to describe how to configure a database to use this procedure, or how to perform the backup itself.

### To back up a volume in a private disk group

- 1 On the primary host, use the following command to see if the volume is associated with a version 20 data change object (DCO) and DCO volume that allow instant snapshots and Persistent FastResync to be used with the volume:

```
# vxprint -g volumedg -F%instant volume
```

If the volume can be used for instant snapshot operations, this command returns `on`; otherwise, it returns `off`.

If the volume was created under VxVM 4.0 or a later release, and it is not associated with a new-style DCO object and DCO volume, add a version 20 DCO and DCO volume.

See [“Preparing a volume for DRL and instant snapshots”](#) on page 360.

If the volume was created before release 4.0 of VxVM, and has any attached snapshot plexes, or is associated with any snapshot volumes, upgrade the volume to use a version 20 DCO.

See [“Upgrading existing volumes to use version 20 DCOs”](#) on page 367.

- 2 On the primary host, use the following command to check whether FastResync is enabled on the volume:

```
# vxprint -g volumedg -F%fastresync volume
```

If FastResync is enabled, this command returns `on`; otherwise, it returns `off`.

If FastResync is disabled, enable it using the following command on the primary host:

```
# vxvol -g volumedg set fastresync=on volume
```

- 3 On the primary host, create a new volume in a separate disk group for use as the snapshot volume.

See [“Creating a volume for use as a full-sized instant or linked break-off snapshot”](#) on page 405.

It is recommended that a snapshot disk group is dedicated to maintaining only those disks that are used for off-host processing.

- 4 On the primary host, link the snapshot volume in the snapshot disk group to the data volume. Enter the following:

```
# vxsnap -g volumedg -b addmir volume mirvol=snapvol \  
mirdg=snapvoldg
```

You can use the `vxsnap snapwait` command to wait for synchronization of the linked snapshot volume to complete. Enter the following:

```
# vxsnap -g volumedg snapwait volume mirvol=snapvol \  
mirdg=snapvoldg
```

This step sets up the snapshot volumes, and starts tracking changes to the original volumes.

When you are ready to create a backup, go to step 5.

- 5 On the primary host, suspend updates to the volume that contains the database tables. A database may have a hot backup mode that lets you do this by temporarily suspending writes to its tables.
- 6 On the primary host, create the snapshot volume, *snapvol*, by running the following command:

```
# vxsnap -g volumedg make \  
source=volume/snapvol=snapvol/snapdg=snapvoldg
```

If a database spans more than one volume, you can specify all the volumes and their snapshot volumes using one command, as follows:

```
# vxsnap -g dbasedg make \  
source=vol1/snapvol=snapvol1/snapdg=sdg \  
source=vol2/snapvol=snapvol2/snapdg=sdg \  
source=vol3/snapvol=snapvol3/snapdg=sdg
```

- 7 On the primary host, if you temporarily suspended updates to a volume in step 5, release all the database tables from hot backup mode.
- 8 On the primary host, deport the snapshot volume's disk group using the following command:

```
# vxdg deport snapvoldg
```

- 9 On the OHP host where the backup is to be performed, use the following command to import the snapshot volume's disk group:

```
# vxdg import snapvoldg
```

- 10** The snapshot volume is initially disabled following the import. On the OHP host, use the following commands to recover and restart the snapshot volume:

```
# vxrecover -g snapvoldg -m snapvol  
# vxvol -g snapvoldg start snapvol
```

- 11** On the OHP host, back up the snapshot volume. If you need to remount the file system in the volume to back it up, first run `fsck` on the volume. The following are sample commands for checking and mounting a file system:

```
# fsck -F vxfs /dev/vx/rdisk/snapvoldg/snapvol  
# mount -F vxfs /dev/vx/dsk/snapvoldg/snapvol mount_point
```

At this point, back up the file system and use the following command to unmount it:

```
# umount mount_point
```

- 12** On the OHP host, use the following command to deport the snapshot volume's disk group:

```
# vxdg deport snapvoldg
```

- 13** On the primary host, re-import the snapshot volume's disk group using the following command:

```
# vxdg import snapvoldg
```

- 14 The snapshot volume is initially disabled following the import. Use the following commands on the primary host to recover and restart the snapshot volume:

```
# vxrecover -g snapvoldg -m snapvol
# vxvol -g snapvoldg start snapvol
```

- 15 On the primary host, reattach the snapshot volume to its original volume using the following command:

```
# vxsnap -g snapvoldg reattach snapvol source=vol \
  sourcedg=volumedg
```

For example, to reattach the snapshot volumes *svol1*, *svol2* and *svol3*:

```
# vxsnap -g sdg reattach svol1 \
  source=vol1 sourcedg=dbasedg \
  svol2 source=vol2 sourcedg=dbasedg \
  svol3 source=vol3 sourcedg=dbasedg
```

You can use the `vxsnap snapwait` command to wait for synchronization of the linked snapshot volume to complete:

```
# vxsnap -g volumedg snapwait volume mirvol=snapvol
```

Repeat steps 5 through 15 each time that you need to back up the volume.

## Implementing decision support

This section describes a procedure for implementing off-host decision support for a volume in a private disk group. The intention is to present an outline of how to set up a replica database. It is beyond the scope of this guide to describe how to configure a database to use this procedure.

**To set up a replica database using the table files that are configured within a volume in a private disk group**

- 1 Use the following command on the primary host to see if the volume is associated with a version 20 data change object (DCO) and DCO volume that allow instant snapshots and Persistent FastResync to be used with the volume:

```
# vxprint -g volumedg -F%instant volume
```

This command returns `on` if the volume can be used for instant snapshot operations; otherwise, it returns `off`.

If the volume was created under VxVM 4.0 or a later release, and it is not associated with a new-style DCO object and DCO volume, it must be prepared.

See [“Preparing a volume for DRL and instant snapshots”](#) on page 360.

If the volume was created before release 4.0 of VxVM, and has any attached snapshot plexes, or is associated with any snapshot volumes, it must be upgraded.

See [“Upgrading existing volumes to use version 20 DCOs”](#) on page 367.

- 2 Use the following command on the primary host to check whether FastResync is enabled on a volume:

```
# vxprint -g volumedg -F%fastresync volume
```

This command returns `on` if FastResync is enabled; otherwise, it returns `off`.

If FastResync is disabled, enable it using the following command on the primary host:

```
# vxvol -g volumedg set fastresync=on volume
```

- 3 Prepare the OHP host to receive the snapshot volume that contains the copy of the database tables. This may involve setting up private volumes to contain any redo logs, and configuring any files that are used to initialize the database.
- 4 On the primary host, create a new volume in a separate disk group for use as the snapshot volume.

See [“Creating a volume for use as a full-sized instant or linked break-off snapshot”](#) on page 405.

It is recommended that a snapshot disk group is dedicated to maintaining only those disks that are used for off-host processing.

- 5 On the primary host, link the snapshot volume in the snapshot disk group to the data volume:

```
# vxsnap -g volumedg -b addmir volume mirvol=snapvol \
  mirdg=snapvoldg
```

You can use the `vxsnap snapwait` command to wait for synchronization of the linked snapshot volume to complete:

```
# vxsnap -g volumedg snapwait volume mirvol=snapvol \
  mirdg=snapvoldg
```

This step sets up the snapshot volumes, and starts tracking changes to the original volumes.

When you are ready to create a replica database, proceed to [6](#).

- 6 On the primary host, suspend updates to the volume that contains the database tables. A database may have a hot backup mode that allows you to do this by temporarily suspending writes to its tables.
- 7 Create the snapshot volume, *snapvol*, by running the following command on the primary host:

```
# vxsnap -g volumedg make \
  source=volume/snapvol=snapvol/snapdg=snapvoldg
```

If a database spans more than one volume, you can specify all the volumes and their snapshot volumes using one command, as shown in this example:

```
# vxsnap -g dbasedg make \
  source=vol1/snapvol=snapvol1/snapdg=sdg \
  source=vol2/snapvol=snapvol2/snapdg=sdg \
  source=vol3/snapvol=snapvol3/snapdg=sdg
```

This step sets up the snapshot volumes ready for the backup cycle, and starts tracking changes to the original volumes.

- 8 On the primary host, if you temporarily suspended updates to a volume in step [6](#), release all the database tables from hot backup mode.
- 9 On the primary host, deport the snapshot volume's disk group using the following command:

```
# vxdg deport snapvoldg
```

- 10 On the OHP host where the replica database is to be set up, use the following command to import the snapshot volume's disk group:

```
# vxdg import snapvoldg
```

- 11 The snapshot volume is initially disabled following the import. Use the following commands on the OHP host to recover and restart the snapshot volume:

```
# vxrecover -g snapvoldg -m snapvol  
# vxvol -g snapvoldg start snapvol
```

- 12 On the OHP host, check and mount the snapshot volume. The following are sample commands for checking and mounting a file system:

```
# fsck -F vxfs /dev/vx/rdisk/snapvoldg/snapvol  
# mount -F vxfs /dev/vx/dsk/snapvoldg/snapvol mount_point
```

- 13 On the OHP host, use the appropriate database commands to recover and start the replica database for its decision support role.

At a later time, you can resynchronize the snapshot volume's data with the primary database.

#### To refresh the snapshot plexes from the original volume

- 1 On the OHP host, shut down the replica database, and use the following command to unmount the snapshot volume:

```
# umount mount_point
```

- 2 On the OHP host, use the following command to deport the snapshot volume's disk group:

```
# vxdg deport snapvoldg
```

- 3 On the primary host, re-import the snapshot volume's disk group using the following command:

```
# vxdg import snapvoldg
```



- 4 The snapshot volume is initially disabled following the import. Use the following commands on the primary host to recover and restart the snapshot volume:

```
# vxrecover -g snapvoldg -m snapvol  
# vxvol -g snapvoldg start snapvol
```

- 5 On the primary host, reattach the snapshot volume to its original volume using the following command:

```
# vxsnap -g snapvoldg reattach snapvol source=vol \  
sourcedg=volumedg
```

For example, to reattach the snapshot volumes `svol1`, `svol2` and `svol3`:

```
# vxsnap -g sdg reattach svol1 \  
source=vol1 sourcedg=dbasedg \  
svol2 source=vol2 sourcedg=dbasedg \  
svol3 source=vol3 sourcedg=dbasedg
```

You can use the `vxsnap snapwait` command to wait for synchronization of the linked snapshot volume to complete:

```
# vxsnap -g volumedg snapwait volume mirvol=snapvol
```

You can then proceed to create the replica database, from step 6 in the previous procedure.

See [“To set up a replica database using the table files that are configured within a volume in a private disk group”](#) on page 462.



# Administering hot-relocation

This chapter includes the following topics:

- [About hot-relocation](#)
- [How hot-relocation works](#)
- [How reclamation on a deleted volume works](#)
- [Configuring a system for hot-relocation](#)
- [Displaying spare disk information](#)
- [Marking a disk as a hot-relocation spare](#)
- [Removing a disk from use as a hot-relocation spare](#)
- [Excluding a disk from hot-relocation use](#)
- [Making a disk available for hot-relocation use](#)
- [Configuring hot-relocation to use only spare disks](#)
- [Moving relocated subdisks](#)
- [Modifying the behavior of hot-relocation](#)

## About hot-relocation

If a volume has a disk I/O failure (for example, the disk has an uncorrectable error), Veritas Volume Manager (VxVM) can detach the plex involved in the failure. I/O stops on that plex but continues on the remaining plexes of the volume.

If a disk fails completely, VxVM can detach the disk from its disk group. All plexes on the disk are disabled. If there are any unmirrored volumes on a disk when it is detached, those volumes are also disabled.

Apparent disk failure may not be due to a fault in the physical disk media or the disk controller, but may instead be caused by a fault in an intermediate or ancillary component such as a cable, host bus adapter, or power supply.

The hot-relocation feature in VxVM automatically detects disk failures, and notifies the system administrator and other nominated users of the failures by electronic mail. Hot-relocation also attempts to use spare disks and free disk space to restore redundancy and to preserve access to mirrored and RAID-5 volumes.

See [“How hot-relocation works”](#) on page 468.

If hot-relocation is disabled or you miss the electronic mail, you can use the `vxprint` command or the graphical user interface to examine the status of the disks. You may also see driver error messages on the console or in the system messages file.

Failed disks must be removed and replaced manually.

See [“Removing and replacing disks”](#) on page 148.

For more information about recovering volumes and their data after hardware failure, see the *Veritas Volume Manager Troubleshooting Guide*.

## How hot-relocation works

Hot-relocation allows a system to react automatically to I/O failures on redundant (mirrored or RAID-5) VxVM objects, and to restore redundancy and access to those objects. VxVM detects I/O failures on objects and relocates the affected subdisks to disks designated as spare disks or to free space within the disk group. VxVM then reconstructs the objects that existed before the failure and makes them redundant and accessible again.

When a partial disk failure occurs (that is, a failure affecting only some subdisks on a disk), redundant data on the failed portion of the disk is relocated. Existing volumes on the unaffected portions of the disk remain accessible.

Hot-relocation is only performed for redundant (mirrored or RAID-5) subdisks on a failed disk. Non-redundant subdisks on a failed disk are not relocated, but the system administrator is notified of their failure.

Hot-relocation is enabled by default and takes effect without the intervention of the system administrator when a failure occurs.

The hot-relocation daemon, `vxrelocd`, detects and reacts to VxVM events that signify the following types of failures:

Disk failure	This is normally detected as a result of an I/O failure from a VxVM object. VxVM attempts to correct the error. If the error cannot be corrected, VxVM tries to access configuration information in the private region of the disk. If it cannot access the private region, it considers the disk failed.
Plex failure	This is normally detected as a result of an uncorrectable I/O error in the plex (which affects subdisks within the plex). For mirrored volumes, the plex is detached.
RAID-5 subdisk failure	This is normally detected as a result of an uncorrectable I/O error. The subdisk is detached.

When `vxrelocd` detects such a failure, it performs the following steps:

- `vxrelocd` informs the system administrator (and other nominated users) by electronic mail of the failure and which VxVM objects are affected.  
See [Partial disk failure mail messages](#).  
See [Complete disk failure mail messages](#).  
See [Modifying the behavior of hot-relocation](#).
- `vxrelocd` next determines if any subdisks can be relocated. `vxrelocd` looks for suitable space on disks that have been reserved as hot-relocation spares (marked `spare`) in the disk group where the failure occurred. It then relocates the subdisks to use this space.
- If no spare disks are available or additional space is needed, `vxrelocd` uses free space on disks in the same disk group, except those disks that have been excluded for hot-relocation use (marked `nohotuse`). When `vxrelocd` has relocated the subdisks, it reattaches each relocated subdisk to its plex.
- Finally, `vxrelocd` initiates appropriate recovery procedures. For example, recovery includes mirror resynchronization for mirrored volumes or data recovery for RAID-5 volumes. It also notifies the system administrator of the hot-relocation and recovery actions that have been taken.

If relocation is not possible, `vxrelocd` notifies the system administrator and takes no further action.

---

**Warning:** Hot-relocation does not guarantee the same layout of data or the same performance after relocation. An administrator should check whether any configuration changes are required after hot-relocation occurs.

---

Relocation of failing subdisks is not possible in the following cases:

- The failing subdisks are on non-redundant volumes (that is, volumes of types other than mirrored or RAID-5).
- There are insufficient spare disks or free disk space in the disk group.
- The only available space is on a disk that already contains a mirror of the failing plex.
- The only available space is on a disk that already contains the RAID-5 log plex or one of its healthy subdisks. Failing subdisks in the RAID-5 plex cannot be relocated.
- If a mirrored volume has a dirty region logging (DRL) log subdisk as part of its data plex, failing subdisks belonging to that plex cannot be relocated.
- If a RAID-5 volume log plex or a mirrored volume DRL log plex fails, a new log plex is created elsewhere. There is no need to relocate the failed subdisks of the log plex.

See the `vxrelocd(1M)` manual page.

[Figure 12-1](#) shows the hot-relocation process in the case of the failure of a single subdisk of a RAID-5 volume.

**Figure 12-1** Example of hot-relocation for a subdisk in a RAID-5 volume

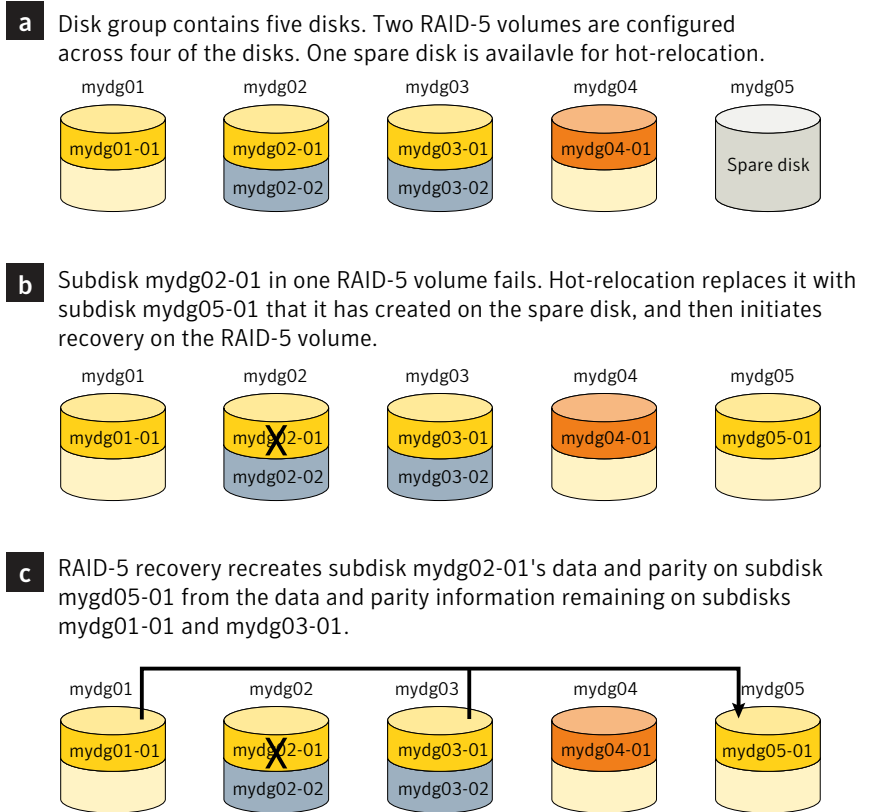

## Partial disk failure mail messages

If hot-relocation is enabled when a plex or disk is detached by a failure, mail indicating the failed objects is sent to `root`. If a partial disk failure occurs, the mail identifies the failed plexes. For example, if a disk containing mirrored volumes fails, you can receive mail information as shown in the following example:

```
To: root
Subject: Volume Manager failures on host teal
Failures have been detected by the Veritas Volume Manager:

failed plexes:
home-02
src-02
```

Mail can be sent to users other than `root`.

See [“Modifying the behavior of hot-relocation”](#) on page 486.

You can determine which disk is causing the failures in the above example message by using the following command:

```
# vxstat -g mydg -s -ff home-02 src-02
```

The `-s` option asks for information about individual subdisks, and the `-ff` option displays the number of failed read and write operations. The following output display is typical:

TYP NAME	FAILED	
	READS	WRITES
sd mydg01-04	0	0
sd mydg01-06	0	0
sd mydg02-03	1	0
sd mydg02-04	1	0

This example shows failures on reading from subdisks `mydg02-03` and `mydg02-04` of disk `mydg02`.

Hot-relocation automatically relocates the affected subdisks and initiates any necessary recovery procedures. However, if relocation is not possible or the hot-relocation feature is disabled, you must investigate the problem and attempt to recover the plexes. Errors can be caused by cabling failures, so check the cables connecting your disks to your system. If there are obvious problems, correct them and recover the plexes using the following command:

```
# vxrecover -b -g mydg home src
```

This starts recovery of the failed plexes in the background (the command prompt reappears before the operation completes). If an error message appears later, or if the plexes become detached again and there are no obvious cabling failures, replace the disk.

See [“Removing and replacing disks”](#) on page 148.

## Complete disk failure mail messages

If a disk fails completely and hot-relocation is enabled, the mail message lists the disk that failed and all plexes that use the disk. For example, you can receive mail as shown in this example display:

```
To: root  
Subject: Volume Manager failures on host teal
```



```
Failures have been detected by the Veritas Volume Manager:
```

```
failed disks:  
mydg02
```

```
failed plexes:  
home-02  
src-02  
mkting-01
```

```
failing disks:  
mydg02
```

This message shows that `mydg02` was detached by a failure. When a disk is detached, I/O cannot get to that disk. The plexes `home-02`, `src-02`, and `mkting-01` were also detached (probably because of the failure of the disk).

One possible cause of the problem could be a cabling error.

See [“Partial disk failure mail messages”](#) on page 471.

If the problem is not a cabling error, replace the disk.

See [“Removing and replacing disks”](#) on page 148.

## How space is chosen for relocation

A spare disk must be initialized and placed in a disk group as a spare before it can be used for replacement purposes. If no disks have been designated as spares when a failure occurs, VxVM automatically uses any available free space in the disk group in which the failure occurs. If there is not enough spare disk space, a combination of spare space and free space is used.

The free space used in hot-relocation must not have been excluded from hot-relocation use. Disks can be excluded from hot-relocation use by using `vxdiskadm`, `vxedit` or Storage Foundation Manager (SFM).

You can designate one or more disks as hot-relocation spares within each disk group. Disks can be designated as spares by using `vxdiskadm`, `vxedit`, or SFM. Disks designated as spares do not participate in the free space model and should not have storage space allocated on them.

When selecting space for relocation, hot-relocation preserves the redundancy characteristics of the VxVM object to which the relocated subdisk belongs. For example, hot-relocation ensures that subdisks from a failed plex are not relocated to a disk containing a mirror of the failed plex. If redundancy cannot be preserved

using any available spare disks and/or free space, hot-relocation does not take place. If relocation is not possible, the system administrator is notified and no further action is taken.

From the eligible disks, hot-relocation attempts to use the disk that is “closest” to the failed disk. The value of “closeness” depends on the controller, target, and disk number of the failed disk. A disk on the same controller as the failed disk is closer than a disk on a different controller. A disk under the same target as the failed disk is closer than one on a different target.

Hot-relocation tries to move all subdisks from a failing drive to the same destination disk, if possible.

If the failing disk is a root disk, hot-relocation only works if it can relocate all of the file systems to the same disk. If none are found, the system administrator is notified through email.

When hot-relocation takes place, the failed subdisk is removed from the configuration database, and VxVM ensures that the disk space used by the failed subdisk is not recycled as free space.

## How reclamation on a deleted volume works

Storage that is no longer in use, needs to be reclaimed by the array. The process of reclaiming storage on an array can be intense on the array. To avoid any impact on regular I/O's to the array, the reclaim operation is made asynchronous. When a volume is deleted the space previously used by the volume is tracked for later asynchronous reclamation. This asynchronous reclamation is handled by `vxrelocd` (or recovery) daemon.

To perform the reclaim operation during less critical time of the system can be controlled by the following two tunables `reclaim_on_delete_wait_period` and `reclaim_on_delete_start_time`.

The default value for these tunables are:

```
reclaim_on_delete_wait_period=1
reclaim_on_delete_start_time=22:00
```

<code>reclaim_on_delete_wait_period</code>	The storage space used by the deleted volume is reclaimed after <code>reclaim_on_delete_wait_period</code> days. The value of the tunable can be anything between -1 to 367. The default is set to 1, that means the volume is deleted the next day. The storage is reclaimed immediately if the value is -1. The storage space is not reclaimed automatically, if the value is greater than 366. It can only be reclaimed manually using <code>vxdisk reclaim</code> command.
<code>reclaim_on_delete_start_time</code>	This tunable specifies the time of the day, the reclaim on the deleted volume is performed. The default time is set to 22:00. This can be changed to any time of the day.

By default, the `vxrelocd` daemon runs everyday at 22:00 hours and reclaims storage on the deleted volume that are a one day old.

The tunables can be changed using the `vxdefault` command.

## Configuring a system for hot-relocation

By designating spare disks and making free space on disks available for use by hot relocation, you can control how disk space is used for relocating subdisks in the event of a disk failure. If the combined free space and space on spare disks is not sufficient or does not meet the redundancy constraints, the subdisks are not relocated.

Find out which disks are spares or are excluded from hot-relocation.

See [“Displaying spare disk information”](#) on page 476.

You can prepare for hot-relocation by designating one or more disks per disk group as hot-relocation spares.

See [“Marking a disk as a hot-relocation spare”](#) on page 476.

If required, you can remove a disk from use as a hot-relocation spare

See [“Removing a disk from use as a hot-relocation spare”](#) on page 478.

If no spares are available at the time of a failure or if there is not enough space on the spares, free space on disks in the same disk group as where the failure occurred is automatically used, unless it has been excluded from hot-relocation use.

See “[Excluding a disk from hot-relocation use](#)” on page 478.

See “[Making a disk available for hot-relocation use](#)” on page 479.

Depending on the locations of the relocated subdisks, you can choose to move them elsewhere after hot-relocation occurs.

See “[Configuring hot-relocation to use only spare disks](#)” on page 480.

After a successful relocation, remove and replace the failed disk.

See “[Removing and replacing disks](#)” on page 148.

## Displaying spare disk information

Use the following command to display information about spare disks that are available for relocation:

```
# vxdbg [-g diskgroup] spare
```

The following is example output:

GROUP	DISK	DEVICE	TAG	OFFSET	LENGTH	FLAGS
mydg	mydg02	c0t2d0s2	c0t2d0s2	0	658007	s

Here `mydg02` is the only disk designated as a spare in the `mydg` disk group. The `LENGTH` field indicates how much spare space is currently available on `mydg02` for relocation.

The following commands can also be used to display information about disks that are currently designated as spares:

- `vxdisk list` lists disk information and displays spare disks with a `spare` flag.
- `vxprint` lists disk and other information and displays spare disks with a `SPARE` flag.
- The `list` menu item on the `vxdiskadm` main menu lists all disks including spare disks.

## Marking a disk as a hot-relocation spare

Hot-relocation allows the system to react automatically to I/O failure by relocating redundant subdisks to other disks. Hot-relocation then restores the affected VxVM objects and data. If a disk has already been designated as a spare in the disk group, the subdisks from the failed disk are relocated to the spare disk. Otherwise, any suitable free space in the disk group is used except for the free space on the disks that were previously excluded from hot-relocation use.

To designate a disk as a hot-relocation spare, enter the following command:

```
# vxedit [-g diskgroup] set spare=on diskname
```

where *diskname* is the disk media name.

For example, to designate `mydg01` as a spare in the disk group, `mydg`, enter the following command:

```
# vxedit -g mydg set spare=on mydg01
```

You can use the `vxdisk list` command to confirm that this disk is now a spare; `mydg01` should be listed with a `spare` flag.

Any VM disk in this disk group can now use this disk as a spare in the event of a failure. If a disk fails, hot-relocation automatically occurs (if possible). You are notified of the failure and relocation through electronic mail. After successful relocation, you may want to replace the failed disk.

### To use `vxdiskadm` to designate a disk as a hot-relocation spare

- 1 Select `Mark a disk as a spare for a disk group` from the `vxdiskadm` main menu.
- 2 At the following prompt, enter a disk media name (such as `mydg01`):

```
Enter disk name [<disk>,list,q,?] mydg01
```

The following notice is displayed when the disk has been marked as spare:

```
VxVM NOTICE V-5-2-219 Marking of mydg01 in mydg as a spare disk  
is complete.
```

- 3 At the following prompt, indicate whether you want to add more disks as spares (`y`) or return to the `vxdiskadm` main menu (`n`):

```
Mark another disk as a spare? [y,n,q,?] (default: n)
```

Any VM disk in this disk group can now use this disk as a spare in the event of a failure. If a disk fails, hot-relocation should automatically occur (if possible). You should be notified of the failure and relocation through electronic mail. After successful relocation, you may want to replace the failed disk.

## Removing a disk from use as a hot-relocation spare

While a disk is designated as a spare, the space on that disk is not used for the creation of VxVM objects within its disk group. If necessary, you can free a spare disk for general use by removing it from the pool of hot-relocation disks.

To remove a spare from the hot-relocation pool, use the following command:

```
# vxedit [-g diskgroup] set spare=off diskname
```

where *diskname* is the disk media name.

For example, to make `mydg01` available for normal use in the disk group, `mydg`, use the following command:

```
# vxedit -g mydg set spare=off mydg01
```

### To use `vxdiskadm` to remove a disk from the hot-relocation pool

- 1 Select **Turn off the spare flag on a disk** from the `vxdiskadm` main menu.
- 2 At the following prompt, enter the disk media name of a spare disk (such as `mydg01`):

```
Enter disk name [<disk>,list,q,?] mydg01
```

The following confirmation is displayed:

```
VxVM NOTICE V-5-2-143 Disk mydg01 in mydg no longer marked as  
a spare disk.
```

- 3 At the following prompt, indicate whether you want to disable more spare disks (y) or return to the `vxdiskadm` main menu (n):

```
Turn off spare flag on another disk? [y,n,q,?] (default: n)
```

## Excluding a disk from hot-relocation use

To exclude a disk from hot-relocation use, use the following command:

```
# vxedit [-g diskgroup] set nohotuse=on diskname
```

where *diskname* is the disk media name.

### To use `vxdiskadm` to exclude a disk from hot-relocation use

- 1 Select `Exclude a disk from hot-relocation use` from the `vxdiskadm` main menu.

- 2 At the following prompt, enter the disk media name (such as `mydg01`):

```
Enter disk name [<disk>,list,q,?] mydg01
```

The following confirmation is displayed:

```
VxVM INFO V-5-2-925 Excluding mydg01 in mydg from hot-  
relocation use is complete.
```

- 3 At the following prompt, indicate whether you want to add more disks to be excluded from hot-relocation (`y`) or return to the `vxdiskadm` main menu (`n`):

```
Exclude another disk from hot-relocation use? [y,n,q,?]  
(default: n)
```

## Making a disk available for hot-relocation use

Free space is used automatically by hot-relocation in case spare space is not sufficient to relocate failed subdisks. You can limit this free space usage by hot-relocation by specifying which free disks should not be touched by hot-relocation. If a disk was previously excluded from hot-relocation use, you can undo the exclusion and add the disk back to the hot-relocation pool.

To make a disk available for hot-relocation use, use the following command:

```
# vxedit [-g diskgroup] set nohotuse=off diskname
```

**To use vxdiskadm to make a disk available for hot-relocation use**

- 1 Select `Make a disk available for hot-relocation use` from the `vxdiskadm` main menu.

- 2 At the following prompt, enter the disk media name (such as `mydg01`):

```
Enter disk name [<disk>,list,q,?] mydg01
```

The following confirmation is displayed:

```
V-5-2-932 Making mydg01 in mydg available for hot-relocation
use is complete.
```

- 3 At the following prompt, indicate whether you want to add more disks to be excluded from hot-relocation (`y`) or return to the `vxdiskadm` main menu (`n`):

```
Make another disk available for hot-relocation use? [y,n,q,?]
(default: n)
```

## Configuring hot-relocation to use only spare disks

If you want VxVM to use only spare disks for hot-relocation, add the following line to the file `/etc/default/vxassist`:

```
spare=only
```

If not enough storage can be located on disks marked as spare, the relocation fails. Any free space on non-spare disks is not used.

## Moving relocated subdisks

When hot-relocation occurs, subdisks are relocated to spare disks and/or available free space within the disk group. The new subdisk locations may not provide the same performance or data layout that existed before hot-relocation took place. You can move the relocated subdisks (after hot-relocation is complete) to improve performance.

You can also move the relocated subdisks of the spare disks to keep the spare disk space free for future hot-relocation needs. Another reason for moving subdisks is to recreate the configuration that existed before hot-relocation occurred.

During hot-relocation, one of the electronic mail messages sent to `root` is shown in the following example:



```
To: root
Subject: Volume Manager failures on host teal
```

```
Attempting to relocate subdisk mydg02-03 from plex home-02.
Dev_offset 0 length 1164 dm_name mydg02 da_name c0t5d0s2.
The available plex home-01 will be used to recover the data.
```

This message has information about the subdisk before relocation and can be used to decide where to move the subdisk after relocation.

Here is an example message that shows the new location for the relocated subdisk:

```
To: root
Subject: Attempting VxVM relocation on host teal
```

```
Volume home Subdisk mydg02-03 relocated to mydg05-01,
but not yet recovered.
```

Before you move any relocated subdisks, fix or replace the disk that failed.

See [“Removing and replacing disks”](#) on page 148.

Once this is done, you can move a relocated subdisk back to the original disk as described in the following sections.

---

**Warning:** During subdisk move operations, RAID-5 volumes are not redundant.

---

## Moving relocated subdisks using vxdiskadm

When a disk has replaced following a failure, you can use the `vxdiskadm` command move the hot-relocated subdisks back to the disk where they originally resided.

### To move the relocated subdisks using vxdiskadm

- 1 Select `Unrelocate` subdisks back to a disk from the `vxdiskadm` main menu.

- 2 This option prompts for the original disk media name first.

Enter the disk media name where the hot-relocated subdisks originally resided at the following prompt:

```
Enter the original disk name [<disk>,list,q,?]
```

If there are no hot-relocated subdisks in the system, `vxdiskadm` displays `Currently there are no hot-relocated disks,` and asks you to press `Return` to continue.

- 3 You are next asked if you want to move the subdisks to a destination disk other than the original disk.

```
Unrelocate to a new disk [y,n,q,?] (default: n)
```

- 4 If moving subdisks to their original offsets is not possible, you can choose to unrelocate the subdisks forcibly to the specified disk, but not necessarily to the same offsets.

```
Use -f option to unrelocate the subdisks if moving to the exact offset fails? [y,n,q,?] (default: n)
```

- 5 If you entered `y` at step 4 to unrelocate the subdisks forcibly, enter `y` or press Return at the following prompt to confirm the operation:

```
Requested operation is to move all the subdisks which were hot-relocated from mydg10 back to mydg10 of disk group mydg. Continue with operation? [y,n,q,?] (default: y)
```

A status message is displayed at the end of the operation.

```
VxVM INFO V-5-2-954 Unrelocate to disk mydg10 is complete.
```

As an alternative to this procedure, use either the `vxassist` command or the `vxunreloc` command directly.

See [“Moving relocated subdisks using vxassist”](#) on page 482.

See [“Moving relocated subdisks using vxunreloc”](#) on page 483.

## Moving relocated subdisks using vxassist

You can use the `vxassist` command to move and unrelocate subdisks. For example, to move the relocated subdisks on `mydg05` belonging to the volume `home` back to `mydg02`, enter the following command.

---

**Note:** The `!` character is a special character in some shells. The following example shows how to escape it in a bash shell.

---

```
# vxassist -g mydg move home \!mydg05 mydg02
```

Here, `\!mydg05` specifies the current location of the subdisks, and `mydg02` specifies where the subdisks should be relocated.

If the volume is enabled, subdisks within detached or disabled plexes, and detached log or RAID-5 subdisks, are moved without recovery of data.

If the volume is not enabled, subdisks within STALE or OFFLINE plexes, and stale log or RAID-5 subdisks, are moved without recovery. If there are other subdisks within a non-enabled volume that require moving, the relocation fails.

For enabled subdisks in enabled plexes within an enabled volume, data is moved to the new location, without loss of either availability or redundancy of the volume.

## Moving relocated subdisks using `vxunreloc`

VxVM hot-relocation allows the system to automatically react to I/O failures on a redundant VxVM object at the subdisk level and then take necessary action to make the object available again. This mechanism detects I/O failures in a subdisk, relocates the subdisk, and recovers the plex associated with the subdisk. After the disk has been replaced, `vxunreloc` allows you to restore the system back to the configuration that existed before the disk failure. `vxunreloc` allows you to move the hot-relocated subdisks back onto a disk that was replaced due to a failure.

When `vxunreloc` is invoked, you must specify the disk media name where the hot-relocated subdisks originally resided. When `vxunreloc` moves the subdisks, it moves them to the original offsets. If you try to unrelocate to a disk that is smaller than the original disk that failed, `vxunreloc` does nothing except return an error.

`vxunreloc` provides an option to move the subdisks to a different disk from where they were originally relocated. It also provides an option to unrelocate subdisks to a different offset as long as the destination disk is large enough to accommodate all the subdisks.

If `vxunreloc` cannot replace the subdisks back to the same original offsets, a `force` option is available that allows you to move the subdisks to a specified disk without using the original offsets.

See the `vxunreloc(1M)` manual page.

The examples in the following sections demonstrate the use of `vxunreloc`.

### Moving hot-relocated subdisks back to their original disk

Assume that `mydg01` failed and all the subdisks were relocated. After `mydg01` is replaced, `vxunreloc` can be used to move all the hot-relocated subdisks back to `mydg01`.

```
# vxunreloc -g mydg mydg01
```

## Moving hot-relocated subdisks back to a different disk

The `vxunreloc` utility provides the `-n` option to move the subdisks to a different disk from where they were originally relocated.

Assume that `mydg01` failed, and that all of the subdisks that resided on it were hot-relocated to other disks. `vxunreloc` provides an option to move the subdisks to a different disk from where they were originally relocated. After the disk is repaired, it is added back to the disk group using a different name, for example, `mydg05`. If you want to move all the hot-relocated subdisks back to the new disk, the following command can be used:

```
# vxunreloc -g mydg -n mydg05 mydg01
```

The destination disk should have at least as much storage capacity as was in use on the original disk. If there is not enough space, the unrellocate operation will fail and none of the subdisks will be moved.

## Forcing hot-relocated subdisks to accept different offsets

By default, `vxunreloc` attempts to move hot-relocated subdisks to their original offsets. However, `vxunreloc` fails if any subdisks already occupy part or all of the area on the destination disk. In such a case, you have two choices:

- Move the existing subdisks somewhere else, and then re-run `vxunreloc`.
- Use the `-f` option provided by `vxunreloc` to move the subdisks to the destination disk, but leave it to `vxunreloc` to find the space on the disk. As long as the destination disk is large enough so that the region of the disk for storing subdisks can accommodate all subdisks, all the hot-relocated subdisks will be unrellocated without using the original offsets.

Assume that `mydg01` failed and the subdisks were relocated and that you want to move the hot-relocated subdisks to `mydg05` where some subdisks already reside. You can use the force option to move the hot-relocated subdisks to `mydg05`, but not to the exact offsets:

```
# vxunreloc -g mydg -f -n mydg05 mydg01
```

## Examining which subdisks were hot-relocated from a disk

If a subdisk was hot relocated more than once due to multiple disk failures, it can still be unrellocated back to its original location. For instance, if `mydg01` failed and a subdisk named `mydg01-01` was moved to `mydg02`, and then `mydg02` experienced disk failure, all of the subdisks residing on it, including the one which was hot-relocated to it, will be moved again. When `mydg02` was replaced, a `vxunreloc`

operation for `mydg02` will do nothing to the hot-relocated subdisk `mydg01-01`. However, a replacement of `mydg01` followed by a `vxunreloc` operation, moves `mydg01-01` back to `mydg01` if `vxunreloc` is run immediately after the replacement.

After the disk that experienced the failure is fixed or replaced, `vxunreloc` can be used to move all the hot-relocated subdisks back to the disk. When a subdisk is hot-relocated, its original disk-media name and the offset into the disk are saved in the configuration database. When a subdisk is moved back to the original disk or to a new disk using `vxunreloc`, the information is erased. The original disk-media name and the original offset are saved in the subdisk records. To print all of the subdisks that were hot-relocated from `mydg01` in the `mydg` disk group, use the following command:

```
# vxprint -g mydg -se 'sd_orig_dmname="mydg01"'
```

## Restarting vxunreloc after errors

`vxunreloc` moves subdisks in three phases:

- `vxunreloc` creates as many subdisks on the specified destination disk as there are subdisks to be unrelocated. The string `UNRELOC` is placed in the `comment` field of each subdisk record.  
Creating the subdisk is an all-or-nothing operation. If `vxunreloc` cannot create all the subdisks successfully, none are created, and `vxunreloc` exits.
- `vxunreloc` moves the data from each subdisk to the corresponding newly created subdisk on the destination disk.
- When all subdisk data moves have been completed successfully, `vxunreloc` sets the `comment` field to the null string for each subdisk on the destination disk whose `comment` field is currently set to `UNRELOC`.

The `comment` fields of all the subdisks on the destination disk remain marked as `UNRELOC` until phase 3 completes. If its execution is interrupted, `vxunreloc` can subsequently re-use subdisks that it created on the destination disk during a previous execution, but it does not use any data that was moved to the destination disk.

If a subdisk data move fails, `vxunreloc` displays an error message and exits. Determine the problem that caused the move to fail, and fix it before re-executing `vxunreloc`.

If the system goes down after the new subdisks are created on the destination disk, but before all the data has been moved, re-execute `vxunreloc` when the system has been rebooted.

---

**Warning:** Do not modify the string `UNRELOC` in the comment field of a subdisk record.

---

## Modifying the behavior of hot-relocation

Hot-relocation is turned on as long as the `vxrelocd` process is running. You should normally leave hot-relocation turned on so that you can take advantage of this feature if a failure occurs. However, if you choose to disable hot-relocation (perhaps because you do not want the free space on your disks to be used for relocation), you can prevent `vxrelocd` from starting at system startup time by editing the startup file that invokes `vxrelocd`. This file is `/lib/svc/method/vxvm-recover` in Solaris 10, or `/etc/init.d/vxvm-recover` in previous releases of the Solaris OS.

If the hot-relocation daemon is disabled, then automatic storage reclamation on deleted volumes is also disabled.

You can alter the behavior of `vxrelocd` as follows:

- 1 To prevent `vxrelocd` starting, comment out the entry that invokes it in the startup file:

```
# nohup vxrelocd root &
```

- 2 By default, `vxrelocd` sends electronic mail to `root` when failures are detected and relocation actions are performed. You can instruct `vxrelocd` to notify additional users by adding the appropriate user names as shown here:

```
nohup vxrelocd root user1 user2 &
```

- 3 To reduce the impact of recovery on system performance, you can instruct `vxrelocd` to increase the delay between the recovery of each region of the volume, as shown in the following example:

```
nohup vxrelocd -o slow[=IOdelay] root &
```

where the optional *IOdelay* value indicates the desired delay in milliseconds. The default value for the delay is 250 milliseconds.

On a Solaris 10 system, after making changes to the way `vxrelocd` is invoked in the startup file, run the following command to notify that the service configuration has changed:

```
# svcadm refresh vxvm/vxvm-recover
```

For previous releases of the Solaris OS, reboot the system.

You can also stop hot-relocation at any time by killing the `vxrelocd` process (this should not be done while a hot-relocation attempt is in progress).

When executing `vxrelocd` manually, either include `/etc/vx/bin` in your `PATH` or specify `vxrelocd`'s absolute pathname, for example:

```
# PATH=/etc/vx/bin:$PATH  
# export PATH  
# nohup vxrelocd root &
```

Alternatively, you can use the following command:

```
# nohup /etc/vx/bin/vxrelocd root user1 user2 &
```

See the `vxrelocd(1M)` manual page.





# Administering cluster functionality

This chapter includes the following topics:

- [Overview of clustering](#)
- [Multiple host failover configurations](#)
- [About the cluster functionality of VxVM](#)
- [Cluster initialization and configuration](#)
- [Dirty region logging in cluster environments](#)
- [Administering VxVM in cluster environments](#)

## Overview of clustering

Tightly-coupled cluster systems are common in the realm of enterprise-scale mission-critical data processing. The primary advantage of clusters is protection against hardware failure. Should the primary node fail or otherwise become unavailable, applications can continue to run by transferring their execution to standby nodes in the cluster. This ability to provide continuous availability of service by switching to redundant hardware is commonly termed failover.

Another major advantage of clustered systems is their ability to reduce contention for system resources caused by activities such as backup, decision support and report generation. Businesses can derive enhanced value from their investment in cluster systems by performing such operations on lightly loaded nodes in the cluster rather than on the heavily loaded nodes that answer requests for service. This ability to perform some operations on the lightly loaded nodes is commonly termed load balancing.

## Overview of cluster volume management

Over the past several years, parallel applications using shared data access have become increasingly popular. Examples of commercially available applications include Oracle Real Application Clusters™ (RAC), Sybase Adaptive Server®, and Informatica Enterprise Cluster Edition. In addition, the semantics of Network File System (NFS), File Transfer Protocol (FTP), and Network News Transfer Protocol (NNTP) allow these workloads to be served by shared data access clusters. Finally, numerous organizations have developed internal applications that take advantage of shared data access clusters.

The cluster functionality of VxVM (CVM) works together with the cluster monitor daemon that is provided by VCS or by the host operating system. The cluster monitor informs VxVM of changes in cluster membership. Each node starts up independently and has its own cluster monitor plus its own copies of the operating system and VxVM/CVM. When a node joins a cluster, it gains access to shared disk groups and volumes. When a node leaves a cluster, it loses access to these shared objects. A node joins a cluster when you issue the appropriate command on that node.

---

**Warning:** The CVM functionality of VxVM is supported only when used in conjunction with a cluster monitor that has been configured correctly to work with VxVM.

---

[Figure 13-1](#) shows a simple cluster arrangement consisting of four nodes with similar or identical hardware characteristics (CPUs, RAM and host adapters), and configured with identical software (including the operating system).

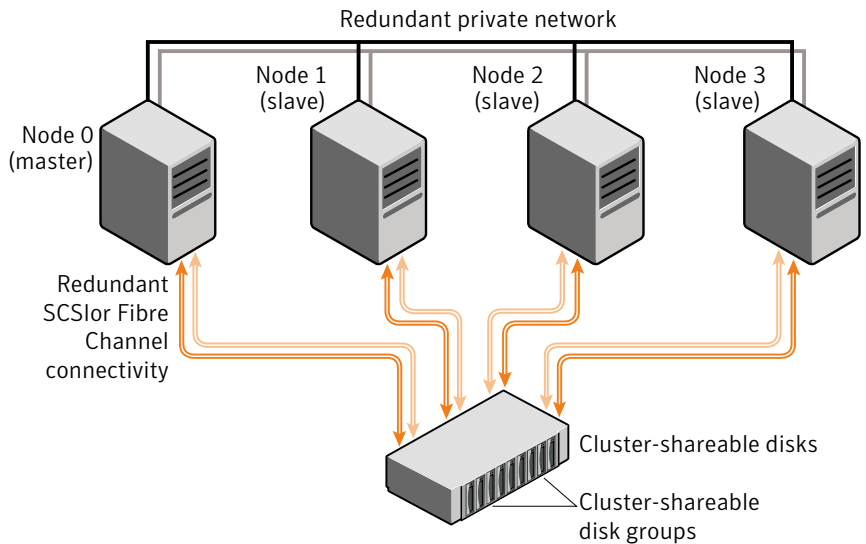
**Figure 13-1** Example of a 4-node CVM cluster

To the cluster monitor, all nodes are the same. VxVM objects configured within shared disk groups can potentially be accessed by all nodes that join the cluster. However, the CVM functionality of VxVM requires that one node act as the master node; all other nodes in the cluster are slave nodes. Any node is capable of being the master node, and it is responsible for coordinating certain VxVM activities.

In this example, node 0 is configured as the master node and nodes 1, 2 and 3 are configured as CVM slave nodes. The nodes are fully connected by a private network and they are also separately connected to shared external storage (either disk arrays or JBODs: just a bunch of disks) via SCSI or Fibre Channel in a Storage Area Network (SAN).

In this example, each node has two independent paths to the disks, which are configured in one or more cluster-shareable disk groups. Multiple paths provide resilience against failure of one of the paths, but this is not a requirement for cluster configuration. Disks may also be connected by single paths.

The private network allows the nodes to share information about system resources and about each other's state. Using the private network, any node can recognize which other nodes are currently active, which are joining or leaving the cluster, and which have failed. The private network requires at least two communication channels to provide redundancy against one of the channels failing. If only one channel were used, its failure would be indistinguishable from node failure—a condition known as network partitioning.

You must run commands that configure or reconfigure VxVM objects on the master node. Tasks that must be initiated from the master node include setting up shared disk groups, creating and reconfiguring volumes, and performing snapshot operations.

The first node to join a cluster performs the function of master node. If the master node leaves a cluster, one of the slave nodes is chosen to be the new master.

## Private and shared disk groups

The following types of disk groups are defined:

**Private disk group** Belongs to only one node. A private disk group can only be imported by one system. LUNs in a private disk group may be physically accessible from one or more systems, but access is restricted to only one system at a time.

The boot disk group (usually aliased by the reserved disk group name `bootdg`) is always a private disk group.

**Shared disk group** Can be shared by all nodes. A shared (or cluster-shareable) disk group is imported by all cluster nodes. LUNs in a shared disk group must be physically accessible from all systems that may join the cluster.

In a CVM cluster, most disk groups are shared. LUNs in a shared disk group are accessible from all nodes in a cluster, allowing applications on multiple cluster nodes to simultaneously access the same LUN. A volume in a shared disk group can be simultaneously accessed by more than one node in the cluster, subject to license key and disk group activation mode restrictions.

You can use the `vxchg` command to designate a disk group as cluster-shareable.

See [“Importing disk groups as shared”](#) on page 518.

When a disk group is imported as cluster-shareable for one node, each disk header is marked with the cluster ID. As each node subsequently joins the cluster, it recognizes the disk group as being cluster-shareable and imports it. In contrast, a private disk group's disk headers are marked with the individual node's host name. As system administrator, you can import or deport a shared disk group at any time; the operation takes place in a distributed fashion on all nodes.

Each LUN is marked with a unique disk ID. When cluster functionality for VxVM starts on the master, it imports all shared disk groups (except for any that do not have the `autoimport` attribute set). When a slave tries to join a cluster, the master sends it a list of the disk IDs that it has imported, and the slave checks to see if it can access them all. If the slave cannot access one of the listed disks, it abandons its attempt to join the cluster. If it can access all of the listed disks, it joins the

cluster and imports the same shared disk groups as the master. When a node leaves the cluster gracefully, it deports all its imported shared disk groups, but they remain imported on the surviving nodes.

Reconfiguring a shared disk group is performed with the cooperation of all nodes. Configuration changes to the disk group are initiated by the master, and happen simultaneously on all nodes and the changes are identical. Such changes are atomic in nature, which means that they either occur simultaneously on all nodes or not at all.

Whether all members of the cluster have simultaneous read and write access to a cluster-shareable disk group depends on its activation mode setting.

See “[Activation modes of shared disk groups](#)” on page 493.

The data contained in a cluster-shareable disk group is available as long as at least one node is active in the cluster. The failure of a cluster node does not affect access by the remaining active nodes. Regardless of which node accesses a cluster-shareable disk group, the configuration of the disk group looks the same.

---

**Warning:** Applications running on each node can access the data on the VM disks simultaneously. VxVM does not protect against simultaneous writes to shared volumes by more than one node. It is assumed that applications control consistency (by using Veritas Cluster File System or a distributed lock manager, for example).

---

## Activation modes of shared disk groups

A shared disk group must be activated on a node in order for the volumes in the disk group to become accessible for application I/O from that node. The ability of applications to read from or to write to volumes is dictated by the activation mode of a shared disk group. Valid activation modes for a shared disk group are `exclusivewrite`, `readonly`, `sharedread`, `sharedwrite`, and `off` (inactive).

The default activation mode for shared disk groups is `sharedwrite`.

Special uses of clusters, such as high availability (HA) applications and off-host backup, can use disk group activation to explicitly control volume access from different nodes in the cluster

[Table 13-1](#) describes the activation modes.

**Table 13-1** Activation modes for shared disk groups

Activation mode	Description
<code>exclusivewrite</code> (ew)	The node has exclusive write access to the disk group. No other node can activate the disk group for write access.

**Table 13-1** Activation modes for shared disk groups (*continued*)

Activation mode	Description
readonly (ro)	The node has read access to the disk group and denies write access for all other nodes in the cluster. The node has no write access to the disk group. Attempts to activate a disk group for either of the write modes on other nodes fail.
sharedread (sr)	The node has read access to the disk group. The node has no write access to the disk group, however other nodes can obtain write access.
sharedwrite (sw)	The node has write access to the disk group. Attempts to activate the disk group for shared read and shared write access succeed. Attempts to activate the disk group for exclusive write and read-only access fail.
off	The node has neither read nor write access to the disk group. Query operations on the disk group are permitted.

**Table 13-2** summarizes the allowed and conflicting activation modes for shared disk groups.

**Table 13-2** Allowed and conflicting activation modes

Disk group activated in cluster as...	Attempt to activate disk group on another node as...			
	<b>exclusive-write</b>	<b>readonly</b>	<b>sharedread</b>	<b>sharedwrite</b>
exclusivewrite	Fails	Fails	Succeeds	Fails
readonly	Fails	Succeeds	Succeeds	Fails
sharedread	Succeeds	Succeeds	Succeeds	Succeeds
sharedwrite	Fails	Fails	Succeeds	Succeeds

To place activation modes under user control, create a defaults file `/etc/default/vxdg` containing the following lines:

```
enable_activation=true
default_actv_mode=activation-mode
```

The *activation-mode* is one of `exclusivewrite`, `readonly`, `sharedread`, `sharedwrite`, or `off`.

When a shared disk group is created or imported, it is activated in the specified mode. When a node joins the cluster, all shared disk groups accessible from the node are activated in the specified mode.

The activation mode of a disk group controls volume I/O from different nodes in the cluster. It is not possible to activate a disk group on a given node if it is activated in a conflicting mode on another node in the cluster. When enabling activation using the defaults file, it is recommended that the file be consistent on all nodes in the cluster as in [Table 13-2](#). Otherwise, the results of activation are unpredictable.

If the defaults file is edited while the `vxconfigd` daemon is already running, run the `/sbin/vxconfigd -k -x syslog` command on all nodes to restart the process.

If the default activation mode is anything other than `off`, an activation following a cluster join, or a disk group creation or import can fail if another node in the cluster has activated the disk group in a conflicting mode.

To display the activation mode for a shared disk group, use the `vx dg list diskgroup` command.

See [“Listing shared disk groups”](#) on page 516.

You can also use the `vx dg` command to change the activation mode on a shared disk group.

See [“Changing the activation mode on a shared disk group”](#) on page 520.

It is also possible to configure a volume so that it can only be opened by a single node in a cluster.

See [“Creating volumes with exclusive open access by a node”](#) on page 521.

See [“Setting exclusive open access to a volume by a node”](#) on page 521.

## Connectivity policy of shared disk groups

A shared disk group provides concurrent read and write access to the volumes that it contains for all nodes in a cluster. A shared disk group can only be created on the master node. This has the following advantages and implications:

- All nodes in the cluster see exactly the same configuration.
- Only the master node can change the configuration.
- Any changes on the master node are automatically coordinated and propagated to the slave nodes in the cluster.

- Any failures that require a configuration change must be sent to the master node so that they can be resolved correctly.
- As the master node resolves failures, all the slave nodes are correctly updated. This ensures that all nodes have the same view of the configuration.

The practical implication of this design is that I/O failure on any node results in the configuration of all nodes being changed. This is known as the global detach policy. However, in some cases, it is not desirable to have all nodes react in this way to I/O failure. To address this, an alternate way of responding to I/O failures, known as the local detach policy, was introduced.

The local detach policy is intended for use with shared mirrored volumes in a cluster. This policy prevents I/O failure on any of the nodes in the cluster from causing a plex to be detached. This would require the plex to be resynchronized when it is subsequently reattached. The local detach policy is available for disk groups that have a version number of 120 or greater.

For small mirrored volumes, non-mirrored volumes, volumes that use hardware mirrors, and volumes in private disk groups, there is no benefit in configuring the local detach policy. In most cases, it is recommended that you use the default global detach policy.

The choice between local and global detach policies is one of node availability versus plex availability when an individual node loses access to disks. Select the local detach policy for a diskgroup if you are using mirrored volumes within it, and would prefer a single node to lose write access to a volume rather than a plex of the volume being detached clusterwide. i.e. you consider the availability of your data (retaining mirrors) more important than any one node in the cluster. This will typically only apply in larger clusters, and where a parallel application is being used that can seamlessly provide the same service from the other nodes. For example, this option is not appropriate for fast failover configurations. Select the global detach policy in all other cases.

In the event of the master node losing access to all the disks containing log/config copies, the disk group failure policy is triggered. At this point no plexes can be detached, as this requires access to the log/config copies, no configuration changes to the disk group can be made, and any action requiring the kernel to write to the klog (first open, last close, mark dirty etc) will fail. If this happened in releases prior to 4.1, the master node always disabled the disk group. Release 4.1 introduces the disk group failure policy, which allows you to change this behavior for critical disk groups. This policy is only available for disk groups that have a version number of 120 or greater.

See [“Global detach policy”](#) on page 497.

See [“Local detach policy”](#) on page 497.



See [“Disk group failure policy”](#) on page 499.

See [“Guidelines for failure policies”](#) on page 499.

## Global detach policy

---

**Warning:** The global detach policy must be selected when Dynamic MultiPathing (DMP) is used to manage multipathing on Active/Passive arrays. This ensures that all nodes correctly coordinate their use of the active path.

---

The global detach policy is the traditional and default policy for all nodes on the configuration. If there is a read or write I/O failure on a slave node, the master node performs the usual I/O recovery operations to repair the failure, and, if required, the plex is detached cluster-wide. All nodes remain in the cluster and continue to perform I/O, but the redundancy of the mirrors is reduced. When the problem that caused the I/O failure has been corrected, the disks should be re-attached and the mirrors that were detached must be recovered before the redundancy of the data can be restored.

## Local detach policy

The local detach policy is designed to support failover applications in large clusters where the redundancy of the volume is more important than the number of nodes that can access the volume. If there is a write failure on a any node, the usual I/O recovery operations are performed to repair the failure, and additionally all the nodes are contacted to see if the disk is still accessible to them. If the write failure is local, and only seen by a single node, I/O is stopped for the node that first saw the failure, and an error is returned to the application using the volume. The write failure is global if more than one node sees the failure. The volume is not disabled.

If required, configure the cluster management software to move the application to a different node, and/or remove the node that saw the failure from the cluster. The volume continues to return write errors, as long as one mirror of the volume has an error. The volume continues to satisfy read requests as long as one good plex is available.

If the reason for the I/O error is corrected and the node is still a member of the cluster, it can resume performing I/O from/to the volume without affecting the redundancy of the data.

The `vxdg` command can be used to set the disk detach policy on a shared disk group.

See [“Setting the disk detach policy on a shared disk group”](#) on page 520.

**Table 13-3** summarizes the effect on a cluster of I/O failure to the disks in a mirrored volume.

**Table 13-3** Cluster behavior under I/O failure to a mirrored volume for different disk detach policies

Type of I/O failure	Local (diskdetpolicy=local)	Global (diskdetpolicy=global)
Failure of path to one disk in a volume for a single node	Reads fail only if no plexes remain available to the affected node. Writes to the volume fail.	The plex is detached, and I/O from/to the volume continues. An I/O error is generated if no plexes remain.
Failure of paths to all disks in a volume for a single node	I/O fails for the affected node.	The plex is detached, and I/O from/to the volume continues. An I/O error is generated if no plexes remain.
Failure of one or more disks in a volume for all nodes.	The plex is detached, and I/O from/to the volume continues. An I/O error is generated if no plexes remain.	The plex is detached, and I/O from/to the volume continues. An I/O error is generated if no plexes remain.

## Guidelines for choosing detach policies

In most cases it is recommended that you use the global detach policy, and particularly if any of the following conditions apply:

- When an array is seen by DMP as Active/Passive. The local detach policy causes unpredictable behavior for Active/Passive arrays.
- If only non-mirrored, small mirrored, or hardware mirrored volumes are configured. This avoids the system overhead of the extra messaging that is required by the local detach policy.

The local detach policy may be suitable in the following cases:

- When large mirrored volumes are configured. Resynchronizing a reattached plex can degrade system performance. The local detach policy can avoid the need to detach the plex at all. (Alternatively, the dirty region logging (DRL) feature can be used to reduce the amount of resynchronization that is required.)
- For clusters with more than four nodes. Keeping an application running on a particular node is less critical when there are many nodes in a cluster. It may be possible to configure the cluster management software to move an application to a node that has access to the volumes. In addition, load balancing may be able to move applications to a different volume from the one that

experienced the I/O problem. This preserves data redundancy, and other nodes may still be able to perform I/O from/to the volumes on the disk.

## Disk group failure policy

The local detach policy by itself is insufficient to determine the desired behavior if the master node loses access to all disks that contain copies of the configuration database and logs. In this case, the disk group is disabled. As a result, any action that would result in an update to log/config copy will also fail from the other nodes in the cluster. In release 4.1, the disk group failure policy is introduced to determine the behavior of the master node in such cases.

[Table 13-4](#) shows how the behavior of the master node changes according to the setting of the failure policy.

**Table 13-4** Behavior of master node for different failure policies

Type of I/O failure	Leave (dgfailpolicy=leave)	Disable (dgfailpolicy=dgdisable)
Master node loses access to all copies of the logs.	The master node panics with the message “klog update failed” for a failed kernel-initiated transaction, or “cvm config update failed” for a failed user-initiated transaction.	The master node disables the disk group.

The behavior of the master node under the disk group failure policy is independent of the setting of the disk detach policy. If the disk group failure policy is set to `leave`, all nodes panic in the unlikely case that none of them can access the log copies.

The `vx dg` command can be used to set the failure policy on a shared disk group.

See “[Setting the disk group failure policy on a shared disk group](#)” on page 521.

## Guidelines for failure policies

If you have a critical disk group that you do not want to become disabled in the case that the master node loses access to the copies of the logs, set the disk group failure policy to `leave`. This prevents I/O failure on the master node disabling the disk group. However, critical applications running on the master node fail if they lose access to the other shared disk groups. In such a case, it may be preferable to set the policy to `dgdisable`, and to allow the disk group to be disabled.

The default settings for the detach and failure policies are `global` and `dgdisable` respectively. You can use the `vxdg` command to change both the detach and failure policies on a shared disk group, as shown in this example:

```
# vxdg -g diskgroup set diskdetpolicy=local dgfailpolicy=leave
```

## Effect of disk connectivity on cluster reconfiguration

The detach policy, previous I/O errors, or access to disks are not considered when a new master node is chosen. When the master node leaves a cluster, the node that takes over as master of the cluster may already have seen I/O failures for one or more disks. Under the local detach policy, if a node was affected before reconfiguration, and this node then becomes the master, the failure is treated differently from the global detach policy case.

See [“Connectivity policy of shared disk groups”](#) on page 495.

Some failure scenarios do not result in a disk group failure policy being invoked, but can potentially impact the cluster. For example, if the local disk detach policy is in effect, and the new master node has a failed plex, this results in all nodes detaching the plex because the new master is unaffected by the policy.

The detach policy does not change the requirement that a node joining a cluster must have access to all the disks in all shared disk groups. Similarly, a node that is removed from the cluster because of an I/O failure cannot rejoin the cluster until this requirement is met.

## Limitations of shared disk groups

Only raw device access may be performed via CVM. It does not support shared access to file systems in shared volumes unless the appropriate software, such as Veritas Cluster File System, is installed and configured.

---

**Note:** The boot disk group (usually aliased as `bootdg`) cannot be made cluster-shareable. It must be private.

---

The cluster functionality of VxVM does not support RAID-5 volumes, or task monitoring for cluster-shareable disk groups. These features can, however, be used in private disk groups that are attached to specific nodes of a cluster.

If you have RAID-5 volumes in a private disk group that you wish to make shareable, you must first relayout the volumes as a supported volume type such as `stripe-mirror` or `mirror-stripe`. Online relayout of shared volumes is supported provided that it does not involve RAID-5 volumes.

If a shared disk group contains RAID-5 volumes, deport it and then reimport the disk group as private on one of the cluster nodes. Reorganize the volumes into layouts that are supported for shared disk groups, and then deport and reimport the disk group as shared.

## Multiple host failover configurations

Outside the context of CVM, VxVM disk groups can be imported (made available) on only one host at any given time. When a host imports a (private) disk group, the volumes and configuration of that disk group become accessible to the host. If the administrator or system software wants to privately use the same disk group from another host, the host that already has the disk group imported (importing host) must deport (give up access to) the disk group. Once deported, the disk group can be imported by another host.

If two hosts are allowed to access a disk group concurrently without proper synchronization, such as that provided by Oracle RAC, the configuration of the disk group, and possibly the contents of volumes, can be corrupted. Similar corruption can also occur if a file system or database on a raw disk partition is accessed concurrently by two hosts, so this problem is not limited to Veritas Volume Manager.

### Import lock

When a host in a non-CVM environment imports a disk group, an import lock is written on all disks in that disk group. The import lock is cleared when the host deports the disk group. The presence of the import lock prevents other hosts from importing the disk group until the importing host has deported the disk group.

Specifically, when a host imports a disk group, the import normally fails if any disks within the disk group appear to be locked by another host. This allows automatic re-importing of disk groups after a reboot (autoimporting) and prevents imports by another host, even while the first host is shut down. If the importing host is shut down without deporting the disk group, the disk group can only be imported by another host by clearing the host ID lock first (discussed later).

The import lock contains a host ID (the host name) reference to identify the importing host and enforce the lock. Problems can therefore arise if two hosts have the same host ID.

Since Veritas Volume Manager uses the host name as the host ID (by default), it is advisable to change the host name of one machine if another machine shares its host name. To change the host name, use the `vxdctl hostid new_hostname` command.

## Failover

The import locking scheme works well in an environment where disk groups are not normally shifted from one system to another. However, consider a setup where two hosts, Node A and Node B, can access the drives of a disk group. The disk group is initially imported by Node A, but the administrator wants to access the disk group from Node B if Node A crashes. Such a failover scenario can be used to provide manual high availability to data, where the failure of one node does not prevent access to data. Failover can be combined with a “high availability” monitor to provide automatic high availability to data: when Node B detects that Node A has crashed or shut down, Node B imports (fails over) the disk group to provide access to the volumes.

Veritas Volume Manager can support failover, but it relies on the administrator or on an external high-availability monitor, such as VCS, to ensure that the first system is shut down or unavailable before the disk group is imported to another system.

See “[Moving disk groups between systems](#)” on page 233.

See the `vxvg(1M)` manual page.

## Corruption of disk group configuration

If `vxvg import` is used with `-C` (clears locks) and/or `-f` (forces import) to import a disk group that is still in use from another host, disk group configuration corruption is likely to occur. Volume content corruption is also likely if a file system or database is started on the imported volumes before the other host crashes or shuts down.

If this kind of corruption occurs, your configuration must typically be rebuilt from scratch and all data be restored from a backup. There are typically numerous configuration copies for each disk group, but corruption nearly always affects all configuration copies, so redundancy does not help in this case.

As long as the configuration backup daemon, `vxconfigbackupd`, is running, VxVM will backup configurations whenever the configuration is changed. By default, backups are stored in `/etc/vx/cbr/bk`. You may also manually backup the configuration using the `vxconfigbackup` utility. The configuration can be rebuilt using the `vxrestore` utility.

See the `vxconfigbackup`, `vxconfigbackupd`, `vxconfigrestore` man pages.

Disk group configuration corruption usually shows up as missing or duplicate records in the configuration databases. This can result in a variety of `vxconfigd` error messages

```
VxVM vxconfigd ERROR  
V-5-1-569 Disk group group,Disk disk:  
Cannot auto-import group: reason
```

where the *reason* can describe errors such as:

```
Association not resolved  
Association count is incorrect  
Duplicate record in configuration  
Configuration records are inconsistent
```

These errors are typically reported in association with specific disk group configuration copies, but usually apply to all copies. The following is usually displayed along with the error:

```
Disk group has no valid configuration copies
```

If you use the Veritas Cluster Server product, all disk group failover issues can be managed correctly. VCS includes a high availability monitor and includes failover scripts for VxVM, VxFS, and for several popular databases.

The `-t` option to `vxchg` prevents automatic re-imports on reboot and is necessary when used with a host monitor (such as VCS) that controls imports itself, rather than relying on automatic imports by Veritas Volume Manager.

See the *Veritas Volume Manager Troubleshooting Guide*.

## About the cluster functionality of VxVM

A cluster consists of a number of hosts or nodes that share a set of disks. The following are the main benefits of cluster configurations:

Availability	<p>If one node fails, the other nodes can still access the shared disks. When configured with suitable software, mission-critical applications can continue running by transferring their execution to a standby node in the cluster. This ability to provide continuous uninterrupted service by switching to redundant hardware is commonly termed failover.</p> <p>Failover is transparent to users and high-level applications for database and file-sharing. You must configure cluster management software, such as Veritas Cluster Server (VCS), to monitor systems and services, and to restart applications on another node in the event of either hardware or software failure. VCS also allows you to perform general administration tasks such as making nodes join or leave a cluster.</p> <p>Note that a standby node need not remain idle. It could be used to serve other applications in parallel.</p>
Off-host processing	<p>Clusters can reduce contention for system resources by performing activities such as backup, decision support and report generation on the more lightly loaded nodes of the cluster. This allows businesses to derive enhanced value from their investment in cluster systems.</p>

The cluster Volume Manager (CVM) allows up to 32 nodes in a cluster to simultaneously access and manage a set of disks or LUNs under VxVM control. The same logical view of disk configuration and any changes to this view are available on all the nodes. When the CVM functionality is enabled, all cluster nodes can share VxVM objects such as shared disk groups. Private disk groups are supported in the same way as in a non-clustered environment. This chapter discusses the cluster functionality that is provided with VxVM.

---

**Note:** You need an additional license key to use this feature.

---

Products such as Veritas Storage Foundation Cluster File System (SFCFS), and Veritas Cluster Server (VCS) are separately licensed, and are not included with Veritas Volume Manager. See the documentation provided with those products for more information about them.

The Dynamic Multipathing (DMP) feature of VxVM can be used in a clustered environment.

See [“DMP in a clustered environment”](#) on page 171.

Campus cluster configurations (also known as stretch cluster or remote mirror configurations) can also be configured and administered.



# Cluster initialization and configuration

Before any nodes can join a new cluster for the first time, you must supply certain configuration information during cluster monitor setup. This information is normally stored in some form of cluster monitor configuration database. The precise content and format of this information depends on the characteristics of the cluster monitor. The information required by VxVM is as follows:

- cluster ID
- node IDs
- network addresses of nodes
- port addresses

When a node joins the cluster, this information is automatically loaded into VxVM on that node at node startup time.

---

**Note:** To make effective use of the CVM functionality of VxVM requires that you configure a cluster monitor, such as provided by Sun Java™ System Cluster software or VCS. Common Product Installer (CPI) sets up all the information required for configuring the cluster monitor.

---

The cluster monitor startup procedure effects node initialization, and brings up the various cluster components (such as VxVM with cluster support, the cluster monitor, and a distributed lock manager) on the node. Once this is complete, applications may be started. The cluster monitor startup procedure must be invoked on each node to be joined to the cluster.

For VxVM in a cluster environment, initialization consists of loading the cluster configuration information and joining the nodes in the cluster. The first node to join becomes the master node, and later nodes (slaves) join to the master. If two nodes join simultaneously, VxVM chooses the master. After a given node joins, that node has access to the shared disk groups and volumes.

## Cluster reconfiguration

Cluster reconfiguration occurs if a node leaves or joins a cluster. Each node's cluster monitor continuously watches the other cluster nodes. When the membership of the cluster changes, the cluster monitor informs VxVM for it to take appropriate action.

During cluster reconfiguration, VxVM suspends I/O to shared disks. I/O resumes when the reconfiguration completes. Applications may appear to freeze for a short time during reconfiguration.

If other operations, such as VxVM operations or recoveries, are in progress, cluster reconfiguration can be delayed until those operations complete. Volume reconfigurations do not take place at the same time as cluster reconfigurations. Depending on the circumstances, an operation may be held up and restarted later. In most cases, cluster reconfiguration takes precedence. However, if the volume reconfiguration is in the commit stage, it completes first.

See “[Volume reconfiguration](#)” on page 508.

See “[vxclustadm utility](#)” on page 507.

See “[vxclust utility](#)” on page 506.

## vxclust utility

`vxclust` is used when Sun Java System Cluster software acts as the cluster monitor.

Every time there is a cluster reconfiguration, every node currently in the cluster runs the `vxclust` utility at each of several well-orchestrated steps. The cluster monitor facilities ensure that the same step is executed on all nodes at the same time. A given step only starts when the previous one has completed on all nodes. At each step in the reconfiguration, the `vxclust` utility determines what the CVM functionality of VxVM should do next. After informing VxVM of its next action, the `vxclust` utility waits for the outcome (success, failure, or retry) and communicates that to the cluster monitor.

If a node does not respond to a the `vxclust` utility request within a specific timeout period, that node aborts. The `vxclust` utility then decides whether to restart the reconfiguration or give up, depending on the circumstances. If the cause of the reconfiguration is a local, uncorrectable error, `vxclust` gives up. If a node cannot complete an operation because another node has left, the surviving node times out. In this case, the `vxclust` utility requests a reconfiguration with the expectation that another node will leave. If no other node leaves, the `vxclust` utility causes the local node to leave.

If a reconfiguration step fails, the `vxclust` utility returns an error to the cluster monitor. The cluster monitor may decide to abort the node, causing its immediate departure from the cluster. Any I/O in progress to the shared disk fails and access to the shared disks is stopped.

`vxclust` decides what actions to take when it is informed of changes in the cluster. If a new master node is required (due to failure of the previous master), `vxclust` determines which node becomes the new master.

## vxclustadm utility

The `vxclustadm` command provides an interface to the CVM functionality of VxVM when VCS is used as the cluster monitor. It is also called during cluster startup and shutdown. In the absence of a cluster monitor, `vxclustadm` can also be used to activate or deactivate the CVM functionality of VxVM on any node in a cluster.

The `startnode` keyword to `vxclustadm` starts CVM functionality on a cluster node by passing cluster configuration information to the VxVM kernel. In response to this command, the kernel and the VxVM configuration daemon, `vxconfigd`, perform initialization.

The `stopnode` keyword stops CVM functionality on a node. It waits for all outstanding I/O to complete and for all applications to close shared volumes.

The `reinit` keyword allows nodes to be added to or removed from a cluster without stopping the cluster. Before running this command, the cluster configuration file must have been updated with information about the supported nodes in the cluster.

The `nidmap` keyword prints a table showing the mapping between CVM node IDs in VxVM's cluster-support subsystem and node IDs in the cluster monitor. It also prints the state of the nodes in the cluster.

The `nodestate` keyword reports the state of a cluster node and also the reason for the last abort of the node as shown in this example:

```
# /etc/vx/bin/vxclustadm nodestate
```

```
state: out of cluster
reason: user initiated stop
```

**Table 13-5** lists the various reasons that may be given for a node abort.

**Table 13-5** Node abort messages

Reason	Description
cannot find disk on slave node	Missing disk or bad disk on the slave node.
cannot obtain configuration data	The node cannot read the configuration data due to an error such as disk failure.
cluster device open failed	Open of a cluster device failed.
clustering license mismatch with master node	Clustering license does not match that on the master node.
clustering license not available	Clustering license cannot be found.

**Table 13-5** Node abort messages (*continued*)

Reason	Description
connection refused by master	Join of a node refused by the master node.
disk in use by another cluster	A disk belongs to a cluster other than the one that a node is joining.
join timed out during reconfiguration	Join of a node has timed out due to reconfiguration taking place in the cluster.
klog update failed	Cannot update kernel log copies during the join of a node.
master aborted during join	Master node aborted while another node was joining the cluster.
protocol version out of range	Cluster protocol version mismatch or unsupported version.
recovery in progress	Volumes that were opened by the node are still recovering.
transition to role failed	Changing the role of a node to be the master failed.
user initiated abort	Node is out of cluster due to an abort initiated by the user or by the cluster monitor.
user initiated stop	Node is out of cluster due to a stop initiated by the user or by the cluster monitor.
vxconfigd is not enabled	The VxVM configuration daemon is not enabled.

See the `vxclustadm(1M)` manual page.

## Volume reconfiguration

Volume reconfiguration is the process of creating, changing, and removing VxVM objects such as disk groups, volumes and plexes. In a cluster, all nodes co-operate to perform such operations. The `vxconfigd` daemons play an active role in volume reconfiguration. For reconfiguration to succeed, a `vxconfigd` daemon must be running on each of the nodes.

See “[vxconfigd daemon](#)” on page 509.

A volume reconfiguration transaction is initiated by running a VxVM utility on the master node. The utility contacts the local `vxconfigd` daemon on the master

node, which validates the requested change. For example, `vxconfigd` rejects an attempt to create a new disk group with the same name as an existing disk group. The `vxconfigd` daemon on the master node then sends details of the changes to the `vxconfigd` daemons on the slave nodes. The `vxconfigd` daemons on the slave nodes then perform their own checking. For example, each slave node checks that it does not have a private disk group with the same name as the one being created; if the operation involves a new disk, each node checks that it can access that disk. When the `vxconfigd` daemons on all the nodes agree that the proposed change is reasonable, each notifies its kernel. The kernels then co-operate to either commit or to abandon the transaction. Before the transaction can be committed, all of the kernels ensure that no I/O is underway, and block any I/O issued by applications until the reconfiguration is complete. The master node is responsible both for initiating the reconfiguration, and for coordinating the commitment of the transaction. The resulting configuration changes appear to occur simultaneously on all nodes.

If a `vxconfigd` daemon on any node goes away during reconfiguration, all nodes are notified and the operation fails. If any node leaves the cluster, the operation fails unless the master has already committed it. If the master node leaves the cluster, the new master node, which was previously a slave node, completes or fails the operation depending on whether or not it received notification of successful completion from the previous master node. This notification is performed in such a way that if the new master does not receive it, neither does any other slave.

If a node attempts to join a cluster while a volume reconfiguration is being performed, the result of the reconfiguration depends on how far it has progressed. If the kernel has not yet been invoked, the volume reconfiguration is suspended until the node has joined the cluster. If the kernel has been invoked, the node waits until the reconfiguration is complete before joining the cluster.

When an error occurs, such as when a check on a slave fails or a node leaves the cluster, the error is returned to the utility and a message is sent to the console on the master node to identify on which node the error occurred.

## **vxconfigd daemon**

The VxVM configuration daemon, `vxconfigd`, maintains the configuration of VxVM objects. It receives cluster-related instructions from the `vxclust` utility under Sun Java System Cluster software, or from the kernel when running VCS. A separate copy of `vxconfigd` runs on each node, and these copies communicate with each other over a network. When invoked, a VxVM utility communicates with the `vxconfigd` daemon running on the same node; it does not attempt to connect with `vxconfigd` daemons on other nodes. During cluster startup,

SunCluster or VCS prompts `vxconfigd` to begin cluster operation and indicates whether it is a master node or a slave node.

When a node is initialized for cluster operation, the `vxconfigd` daemon is notified that the node is about to join the cluster and is provided with the following information from the cluster monitor configuration database:

- cluster ID
- node IDs
- master node ID
- role of the node
- network address of the node

On the master node, the `vxconfigd` daemon sets up the shared configuration by importing shared disk groups, and informs the `vxclust` utility (for SunCluster) or the kernel (for VCS) when it is ready for the slave nodes to join the cluster.

On slave nodes, the `vxconfigd` daemon is notified when the slave node can join the cluster. When the slave node joins the cluster, the `vxconfigd` daemon and the VxVM kernel communicate with their counterparts on the master node to set up the shared configuration.

When a node leaves the cluster, the kernel notifies the `vxconfigd` daemon on all the other nodes. The master node then performs any necessary cleanup. If the master node leaves the cluster, the kernels select a new master node and the `vxconfigd` daemons on all nodes are notified of the choice.

The `vxconfigd` daemon also participates in volume reconfiguration.

See [“Volume reconfiguration”](#) on page 508.

## vxconfigd daemon recovery

In a cluster, the `vxconfigd` daemons on the slave nodes are always connected to the `vxconfigd` daemon on the master node. If the `vxconfigd` daemon is stopped, volume reconfiguration cannot take place. Other nodes can join the cluster if the `vxconfigd` daemon is not running on the slave nodes.

If the `vxconfigd` daemon stops, different actions are taken depending on which node this occurred:

- If the `vxconfigd` daemon is stopped on the master node, the `vxconfigd` daemons on the slave nodes periodically attempt to rejoin to the master node. Such attempts do not succeed until the `vxconfigd` daemon is restarted on the master. In this case, the `vxconfigd` daemons on the slave nodes have not lost

information about the shared configuration, so that any displayed configuration information is correct.

- If the `vxconfigd` daemon is stopped on a slave node, the master node takes no action. When the `vxconfigd` daemon is restarted on the slave, the slave `vxconfigd` daemon attempts to reconnect to the master daemon and to re-acquire the information about the shared configuration. (Neither the kernel view of the shared configuration nor access to shared disks is affected.) Until the `vxconfigd` daemon on the slave node has successfully reconnected to the `vxconfigd` daemon on the master node, it has very little information about the shared configuration and any attempts to display or modify the shared configuration can fail. For example, shared disk groups listed using the `vxdbg list` command are marked as `disabled`; when the rejoin completes successfully, they are marked as `enabled`.
- If the `vxconfigd` daemon is stopped on both the master and slave nodes, the slave nodes do not display accurate configuration information until `vxconfigd` is restarted on the master and slave nodes, and the daemons have reconnected.

If the `vxclust` utility (for SunCluster) or the CVM agent (for VCS) determines that the `vxconfigd` daemon has stopped on a node, `vxconfigd` is restarted automatically.

---

**Warning:** The `-r` reset option to `vxconfigd` restarts the `vxconfigd` daemon and recreates all states from scratch. This option cannot be used to restart `vxconfigd` while a node is joined to a cluster because it causes cluster information to be discarded.

---

It may sometimes be necessary to restart `vxconfigd` manually in a VCS controlled cluster to resolve a VxVM issue.

### To restart vxconfigd manually

- 1 Use the following command to disable failover on any service groups that contain VxVM objects:

```
# hagr -freeze groupname
```

- 2 Enter the following command to stop and restart the VxVM configuration daemon on the affected node:

```
# vxconfigd -k
```

- 3 Use the following command to re-enable failover for the service groups that you froze in step 1:

```
# hagr -unfreeze groupname
```

## Node shutdown

Although it is possible to shut down the cluster on a node by invoking the shutdown procedure of the node's cluster monitor, this procedure is intended for terminating cluster components after stopping any applications on the node that have access to shared storage. VxVM supports clean node shutdown, which allows a node to leave the cluster gracefully when all access to shared volumes has ceased. The host is still operational, but cluster applications cannot be run on it.

The CVM functionality of VxVM maintains global state information for each volume. This enables VxVM to determine which volumes need to be recovered when a node crashes. When a node leaves the cluster due to a crash or by some other means that is not clean, VxVM determines which volumes may have writes that have not completed and the master node resynchronizes these volumes. It can use dirty region logging (DRL) or FastResync if these are active for any of the volumes.

Clean node shutdown must be used after, or in conjunction with, a procedure to halt all cluster applications. Depending on the characteristics of the clustered application and its shutdown procedure, a successful shutdown can require a lot of time (minutes to hours). For instance, many applications have the concept of draining, where they accept no new work, but complete any work in progress before exiting. This process can take a long time if, for example, a long-running transaction is active.

When the VxVM shutdown procedure is invoked, it checks all volumes in all shared disk groups on the node that is being shut down. The procedure then either continues with the shutdown, or fails for one of the following reasons:



- If all volumes in shared disk groups are closed, VxVM makes them unavailable to applications. Because all nodes are informed that these volumes are closed on the leaving node, no resynchronization is performed.
- If any volume in a shared disk group is open, the shutdown procedure fails. The shutdown procedure can be repeatedly retried until it succeeds. There is no timeout checking in this operation—it is intended as a service that verifies that the clustered applications are no longer active.

Once shutdown succeeds, the node has left the cluster. It is not possible to access the shared volumes until the node joins the cluster again.

Since shutdown can be a lengthy process, other reconfiguration can take place while shutdown is in progress. Normally, the shutdown attempt is suspended until the other reconfiguration completes. However, if it is already too far advanced, the shutdown may complete first.

## Cluster shutdown

If all nodes leave a cluster, shared volumes must be recovered when the cluster is next started if the last node did not leave cleanly, or if resynchronization from previous nodes leaving uncleanly is incomplete. CVM automatically handles the recovery and resynchronization tasks when a node joins the cluster.

## Dirty region logging in cluster environments

Dirty region logging (DRL) is an optional property of a volume that provides speedy recovery of mirrored volumes after a system failure. DRL is supported in cluster-shareable disk groups. This section provides a brief overview of how DRL behaves in a cluster environment.

In a cluster environment, the VxVM implementation of DRL differs slightly from the normal implementation.

A dirty region log on a system without cluster support has a recovery map and a single active map. A CVM DRL, however, has a single recovery map per cluster and one active map per cluster node.

The dirty region log size in clusters is typically larger than in non-clustered systems, as it must accommodate a recovery map plus active maps for each node in the cluster. The size of each map within the dirty region log is one or more whole blocks. The `vxassist` command automatically allocates a sufficiently large dirty region log for the size of the volume and the number of nodes.

It is possible to reimport a non-shared disk group (and its volumes) as a shared disk group in a cluster environment. However, the dirty region logs of the imported disk group may be considered invalid and a full recovery may result.

If a shared disk group is imported as a private disk group on a system without cluster support, VxVM considers the logs of the shared volumes to be invalid and conducts a full volume recovery. After the recovery completes, VxVM uses DRL.

The cluster functionality of VxVM can perform a DRL recovery on a non-shared volume. However, if such a volume is moved to a VxVM system with cluster support and imported as shared, the dirty region log is probably too small to accommodate maps for all the cluster nodes. VxVM then marks the log invalid and performs a full recovery anyway. Similarly, moving a DRL volume from a two-node cluster to a four-node cluster can result in too small a log size, which the cluster functionality of VxVM handles with a full volume recovery. In both cases, you must allocate a new log of sufficient size.

See [“Dirty region logging”](#) on page 59.

## How DRL works in a cluster environment

When one or more nodes in a cluster crash, DRL must handle the recovery of all volumes that were in use by those nodes when the crashes occurred. On initial cluster startup, all active maps are incorporated into the recovery map during the volume start operation.

Nodes that crash (that is, leave the cluster as dirty) are not allowed to rejoin the cluster until their DRL active maps have been incorporated into the recovery maps on all affected volumes. The recovery utilities compare a crashed node's active maps with the recovery map and make any necessary updates. Only then can the node rejoin the cluster and resume I/O to the volume (which overwrites the active map). During this time, other nodes can continue to perform I/O.

VxVM tracks which nodes have crashed. If multiple node recoveries are underway in a cluster at a given time, VxVM tracks changes in the state of DRL recovery and prevents I/O collisions.

The master node performs volatile tracking of DRL recovery map updates for each volume, and prevents multiple utilities from changing the recovery map simultaneously.

## Administering VxVM in cluster environments

The following sections describe the administration of VxVM's cluster functionality.

## Requesting node status and discovering the master node

The `vxctl` utility controls the operation of the `vxconfigd` volume configuration daemon. The `-c` option can be used to request cluster information and to find out which node is the master. To determine whether the `vxconfigd` daemon is enabled and/or running, use the following command:

```
vxctl -c mode
```

**Table 13-6** shows the various messages that may be output according to the current status of the cluster node.

**Table 13-6** Cluster status messages

Status message	Description
mode: enabled: cluster active - MASTER master: mozart	The node is the master.
mode: enabled: cluster active - SLAVE master: mozart	The node is a slave.
mode: enabled: cluster active - role not set master: mozart state: joining reconfig: master update	The node has not yet been assigned a role, and is in the process of joining the cluster.
mode: enabled: cluster active - SLAVE master: mozart state: joining	The node is configured as a slave, and is in the process of joining the cluster.
mode: enabled: cluster inactive	The cluster is not active on this node.
mode: booted: master: ts4200-04	Enable root disk encapsulation but not transactions.
mode: disabled:	Disable transactions.

If the `vxconfigd` daemon is disabled, no cluster information is displayed.

See the `vxdtl(1M)` manual page.

## Determining if a LUN is in a shareable disk group

The `vxdisk` utility manages VxVM disks. To use the `vxdisk` utility to determine whether a LUN is part of a cluster-shareable disk group, use the following command:

```
# vxdisk list accessname
```

where *accessname* is the disk access name (or device name).

For example, a portion of the output from this command (for the device `c4t1d0`) is shown here:

```
Device:      c4t1d0
devicetag:   c4t1d0
type:        auto
clusterid:   cvm2
disk:        name=shdg01 id=963616090.1034.cvm2
timeout:     30
group:       name=shdg id=963616065.1032.cvm2
flags:       online ready autoconfig shared imported
...
```

Note that the `clusterid` field is set to `cvm2` (the name of the cluster), and the `flags` field includes an entry for `shared`. The `imported` flag is only set if a node is a part of the cluster and the disk group is imported.

## Listing shared disk groups

`vxdbg` can be used to list information about shared disk groups. To display information for all disk groups, use the following command:

```
# vxdbg list
```

Example output from this command is displayed here:

NAME	STATE	ID
group2	enabled, shared	774575420.1170.teal
group1	enabled, shared	774222028.1090.teal

Shared disk groups are designated with the flag `shared`.

To display information for shared disk groups only, use the following command:

```
# vxdg -s list
```

Example output from this command is as follows:

NAME	STATE	ID
group2	enabled,shared	774575420.1170.teal
group1	enabled,shared	774222028.1090.teal

To display information about one specific disk group, use the following command:

```
# vxdg list diskgroup
```

The following is example output for the command `vxdg list tempdg` on the master:

```
Group:      tempdg
dgid:      1245902808.74.ts4200-04
import-id: 33792.73
flags:     shared cds
version:   150
alignment: 8192 (bytes)
local-activation: shared-write
cluster-actv-modes: ts4200-04=sw ts4200-06=sw ts4200-05=sw
ssb:       on
autotagging: on
detach-policy: global
dg-fail-policy: dgdisable
copies:    nconfig=default nlog=default
config:    seqno=0.1027 permlen=0 free=0 templen=0 loglen=0
```

Note that the `flags` field is set to `shared`. The output for the same command when run on a slave is slightly different. The `local-activation` and `cluster-actv-modes` fields display the activation mode for this node and for each node in the cluster respectively. The `detach-policy` and `dg-fail-policy` fields indicate how the cluster behaves in the event of loss of connectivity to the disks, and to the configuration and log copies on the disks.

## Creating a shared disk group

The command to create shared disk groups can only be run from the master node.

If the cluster software has been run to set up the cluster, a shared disk group can be created using the following command:

```
# vxdg -s init diskgroup [diskname=]devicenames
```

where *diskgroup* is the disk group name, *diskname* is the administrative name chosen for a VM disk, and *devicename* is the device name (or disk access name).

---

**Warning:** The operating system cannot tell if a disk is shared. To protect data integrity when dealing with disks that can be accessed by multiple systems, use the correct designation when adding a disk to a disk group. VxVM allows you to add a disk that is not physically shared to a shared disk group if the node where the disk is accessible is the only node in the cluster. However, this means that other nodes cannot join the cluster. Furthermore, if you attempt to add the same disk to different disk groups (private or shared) on two nodes at the same time, the results are undefined. Perform all configuration on one node only, and preferably on the master node.

---

## Importing disk groups as shared

The command to import shared disk groups can only be run from the master node.

Disk groups can be imported as shared using the `vxdg -s import` command. If the disk groups are set up before the cluster software is run, the disk groups can be imported into the cluster arrangement using the following command:

```
# vxdg -s import diskgroup
```

where *diskgroup* is the disk group name or ID. On subsequent cluster restarts, the disk group is automatically imported as shared. Note that it can be necessary to deport the disk group (using the `vxdg deport diskgroup` command) before invoking the `vxdg` utility.

## Forcibly importing a disk group

You can use the `-f` option to the `vxdg` command to import a disk group forcibly.

---

**Warning:** The force option (`-f`) must be used with caution and only if you are fully aware of the consequences such as possible data corruption.

---

When a cluster is restarted, VxVM can refuse to auto-import a disk group for one of the following reasons:

- A disk in the disk group is no longer accessible because of hardware errors on the disk. In this case, use the following command to forcibly reimport the disk group:

```
# vxdg -s -f import diskgroup
```

Note: After a forced import, the data on the volumes may not be available and some of the volumes may be in the disabled state.

- Some of the disks in the shared disk group are not accessible, so the disk group cannot access all of its disks. In this case, a forced import is unsafe and must not be attempted because it can result in inconsistent mirrors.

## Converting a disk group from shared to private

The command to convert shared disk groups can only be run from the master node.

To convert a shared disk group to a private disk group, first deport it on the master node using this command:

```
# vxdg deport diskgroup
```

Then reimport the disk group on any cluster node using this command:

```
# vxdg import diskgroup
```

## Moving objects between shared disk groups

The command to move objects between shared disk groups can only be run from the master node. You cannot move objects between private and shared disk groups.

You can use the `vxdg move` command to move a self-contained set of VxVM objects such as disks and top-level volumes between disk groups. In a cluster, you can move such objects between private disk groups on any cluster node where those disk groups are imported.

See [“Moving objects between disk groups”](#) on page 263.

## Splitting shared disk groups

You can use the `vxdg split` command to remove a self-contained set of VxVM objects from an imported disk group, and move them to a newly created disk group.

See [“Splitting disk groups”](#) on page 266.

Splitting a private disk group creates a private disk group, and splitting a shared disk group creates a shared disk group. You can split a private disk group on any cluster node where that disk group is imported. The command to split a shared disk group or create a shared target disk group can only be run from the master node.

See [“Moving objects between disk groups”](#) on page 263.

## Joining shared disk groups

You cannot join a private disk group and a shared disk group.

You can use the `vxpdg join` command to merge the contents of two imported disk groups. In a cluster, you can join two private disk groups on any cluster node where those disk groups are imported.

If the source disk group and the target disk group are both shared, you must run the command to perform the join from the master node.

See [“Joining disk groups”](#) on page 267.

## Changing the activation mode on a shared disk group

The activation mode for access by a cluster node to a shared disk group is set directly on that node.

The activation mode of a shared disk group can be changed using the following command:

```
# vxpdg -g diskgroup set activation=mode
```

The activation mode is one of `exclusivewrite` or `ew`, `readonly` or `ro`, `sharedread` or `sr`, `sharedwrite` or `sw`, or `off`.

If you use this command to change the activation mode of a shared disk group, you must first change the activation mode to `off` before setting it to any other value, as shown here:

```
# vxpdg -g myshdg set activation=off  
# vxpdg -g myshdg set activation=readonly
```

See [“Activation modes of shared disk groups”](#) on page 493.

## Setting the disk detach policy on a shared disk group

The disk detach policy for a shared disk group can only be set from the master node.

The `vxpdg` command may be used to set either the `global` or `local` disk detach policy for a shared disk group:

```
# vxpdg -g diskgroup set diskdetpolicy=global|local
```

The default disk detach policy is `global`.

See [“Connectivity policy of shared disk groups”](#) on page 495.



## Setting the disk group failure policy on a shared disk group

The disk group failure policy for a shared disk group can only be set from the master node.

The `vxchg` command may be used to set either the `dgdisable` or `leave` failure policy for a shared disk group:

```
# vxchg -g diskgroup set dgfailpolicy=dgdisable|leave
```

The default failure policy is `dgdisable`.

See “[Disk group failure policy](#)” on page 499.

## Creating volumes with exclusive open access by a node

All shared volumes, including those with exclusive open access, can only be created from the master node.

When using the `vxassist` command to create a volume, you can use the `exclusive=on` attribute to specify that the volume may only be opened by one node in the cluster at a time. For example, to create the mirrored volume `volmir` in the disk group `diskgrp`, and configure it for exclusive open, use the following command:

```
# vxassist -g diskgrp make volmir 5g layout=mirror exclusive=on
```

Multiple opens by the same node are also supported. Any attempts by other nodes to open the volume fail until the final close of the volume by the node that opened it.

Specifying `exclusive=off` instead means that more than one node in a cluster can open a volume simultaneously. This is the default behavior.

## Setting exclusive open access to a volume by a node

Exclusive open access on a volume can only be set from the master node. Ensure that none of the nodes in the cluster have the volume open when setting this attribute.

You can set the `exclusive=on` attribute with the `vxvol` command to specify that an existing volume may only be opened by one node in the cluster at a time.

For example, to set exclusive open on the volume `volmir` in the disk group `diskgrp`, use the following command:

```
# vxvol -g diskgrp set exclusive=on volmir
```

Multiple opens by the same node are also supported. Any attempts by other nodes to open the volume fail until the final close of the volume by the node that opened it.

Specifying `exclusive=off` instead means that more than one node in a cluster can open a volume simultaneously. This is the default behavior.

## Displaying the cluster protocol version

The following command displays the cluster protocol version running on a node:

```
# vxctl list
```

This command produces output similar to the following:

```
Volboot file
version: 3/1
seqno: 0.19
cluster protocol version: 90
hostid: giga
entries:
```

You can also check the existing cluster protocol version using the following command:

```
# vxctl protocolversion
```

This produces output similar to the following:

```
Cluster running at protocol 90
```

## Displaying the supported cluster protocol version range

The following command displays the maximum and minimum protocol version supported by the node and the current protocol version:

```
# vxctl support
```

This command produces out put similar to the following:

```
Support information:
vxconfigd_vrsn:      31
dg_minimum:          20
dg_maximum:          150
kernel:              31
protocol_minimum:    90
```

```
protocol_maximum: 90
protocol_current: 90
```

You can also use the following command to display the maximum and minimum cluster protocol version supported by the current Veritas Volume Manager release:

```
# vxctl protocolrange
```

This produces output similar to the following:

```
minprotoversion: 90, maxprotoversion: 90
```

## Upgrading the cluster protocol version

The cluster protocol version can only be updated from the master node.

After all the nodes in the cluster have been updated to support the new cluster protocol version, you can upgrade the entire cluster using the following command on the master node:

```
# vxctl upgrade
```

## Recovering volumes in shared disk groups

The command to recover volumes can only be run from the master node.

The `vxrecover` utility is used to recover plexes and volumes after disk replacement. When a node leaves a cluster, it can leave some mirrors in an inconsistent state. The `vxrecover` utility can be used to recover such volumes. The `-c` option to `vxrecover` causes it to recover all volumes in shared disk groups. The `vxconfigd` daemon automatically calls the `vxrecover` utility with the `-c` option when necessary.

---

**Warning:** While the `vxrecover` utility is active, there can be some degradation in system performance.

---

## Obtaining cluster performance statistics

The `vxstat` utility returns statistics for specified objects. In a cluster environment, `vxstat` gathers statistics from all of the nodes in the cluster. The statistics give the total usage, by all nodes, for the requested objects. If a local object is specified, its local usage is returned.

You can optionally specify a subset of nodes using the following form of the command:

```
# vxstat -g diskgroup -n node[,node...]
```

where *node* is the CVM node ID number. You can find out the CVM node ID by using the following command:

```
# vxclustadm nidmap
```

If a comma-separated list of nodes is supplied, the `vxstat` utility displays the sum of the statistics for the nodes in the list.

For example, to obtain statistics for node 2, volume `vol1`, use the following command:

```
# vxstat -g group1 -n 2 vol1
```

This command produces output similar to the following:

TYP	NAME	OPERATIONS		BLOCKS		AVG TIME (ms)	
		READ	WRITE	READ	WRITE	READ	WRITE
vol	vol1	2421	0	600000	0	99.0	0.0

To obtain and display statistics for the entire cluster, use the following command:

```
# vxstat -b
```

The statistics for all nodes are summed. For example, if node 1 performed 100 I/O operations and node 2 performed 200 I/O operations, `vxstat -b` displays a total of 300 I/O operations.

# Administering sites and remote mirrors

This chapter includes the following topics:

- [About sites and remote mirrors](#)
- [Making an existing disk group site consistent](#)
- [Configuring a new disk group as a Remote Mirror configuration](#)
- [Fire drill – testing the configuration](#)
- [Changing the site name](#)
- [Administering the Remote Mirror configuration](#)
- [Examples of storage allocation by specifying sites](#)
- [Displaying site information](#)
- [Failure and recovery scenarios](#)

## About sites and remote mirrors

In a Remote Mirror configuration (also known as a campus cluster or stretch cluster) the hosts and storage of a cluster that would usually be located in one place, are instead divided between two or more sites. These sites are typically connected via a redundant high-capacity network that provides access to storage and private link communication between the cluster nodes.

[Figure 14-1](#) shows a typical two-site remote mirror configuration.

**Figure 14-1** Example of a two-site remote mirror configuration

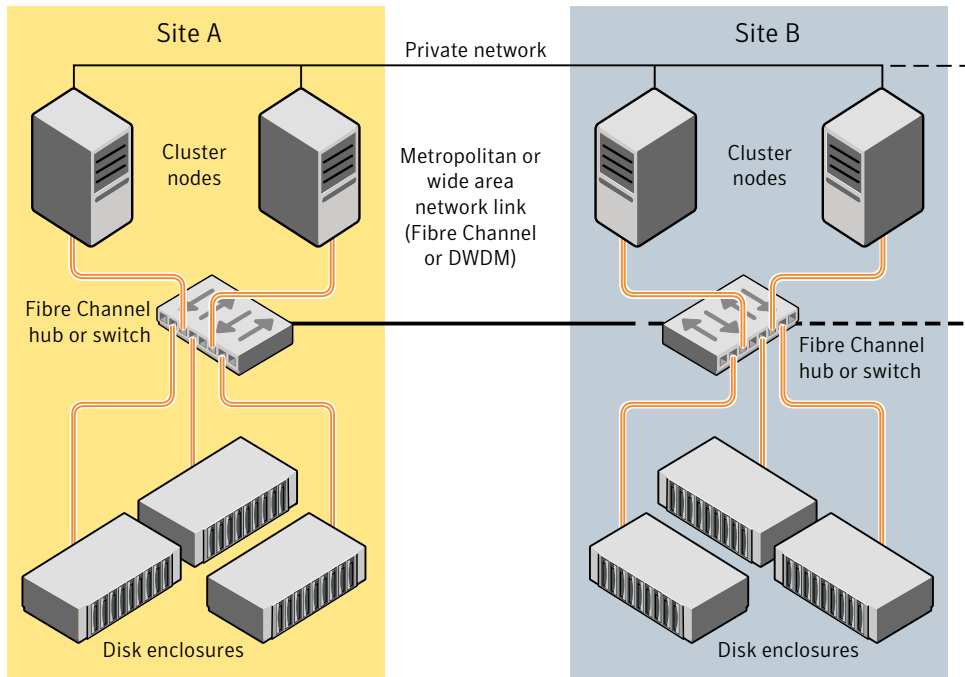

If a disk group is configured across the storage at the sites, and inter-site communication is disrupted, there is a possibility of a serial split brain condition arising if each site continues to update the local disk group configuration copies.

See [“Handling conflicting configuration copies”](#) on page 250.

VxVM provides mechanisms for dealing with the serial split brain condition, monitoring the health of a remote mirror, and testing the robustness of the cluster against various types of failure (also known as fire drill).

For applications and services to function correctly at a site when other sites have become inaccessible, at least one complete plex of each volume must be configured at each site (site-based allocation), and the consistency of the data in the plexes at each site must be ensured (site consistency).

By tagging disks with site names, storage can be allocated from the correct location when creating, resizing or relocating a volume, and when changing a volume’s layout.

[Figure 14-2](#) shows an example of a site-consistent volume with two plexes configured at each of two sites.

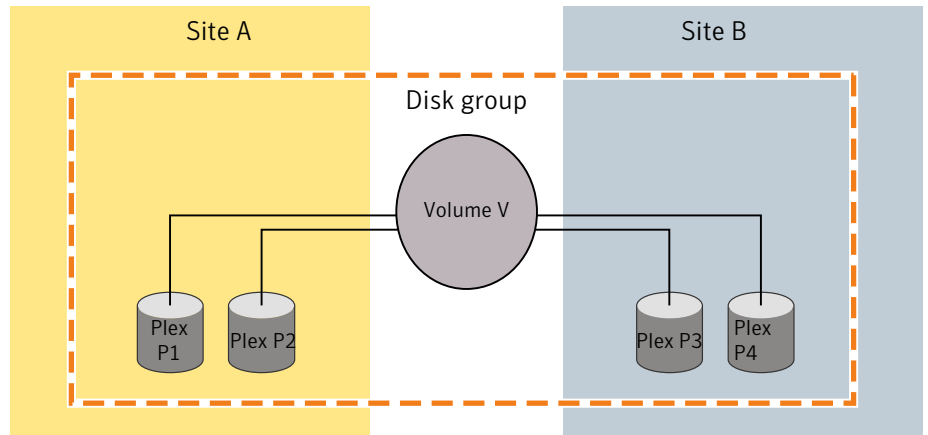
**Figure 14-2** Site-consistent volume with two plexes at each of two sites

The storage for plexes P1 and P2 is allocated storage that is tagged as belonging to site A, and the storage for plexes P3 and P4 is allocated storage that is tagged as belonging to site B.

Although not shown in this figure, DCO log volumes are also mirrored across the sites, and disk group configuration copies are distributed across the sites.

Site consistency means that the data in the plexes for a volume must be consistent at each site. The site consistency of a volume is ensured by detaching a site when its last complete plex fails at that site. If a site fails, all its plexes are detached and the site is said to be detached. If site consistency is not on, only the plex that fails is detached. The remaining volumes and their plexes on that site are not detached.

To enhance read performance, VxVM will service reads from the plexes at the local site where an application is running if the `siteread` read policy is set on a volume. Writes are written to plexes at all sites.

[Figure 14-3](#) shows a configuration with remote storage only that is also supported.

**Figure 14-3** Example of a two-site configuration with remote storage only

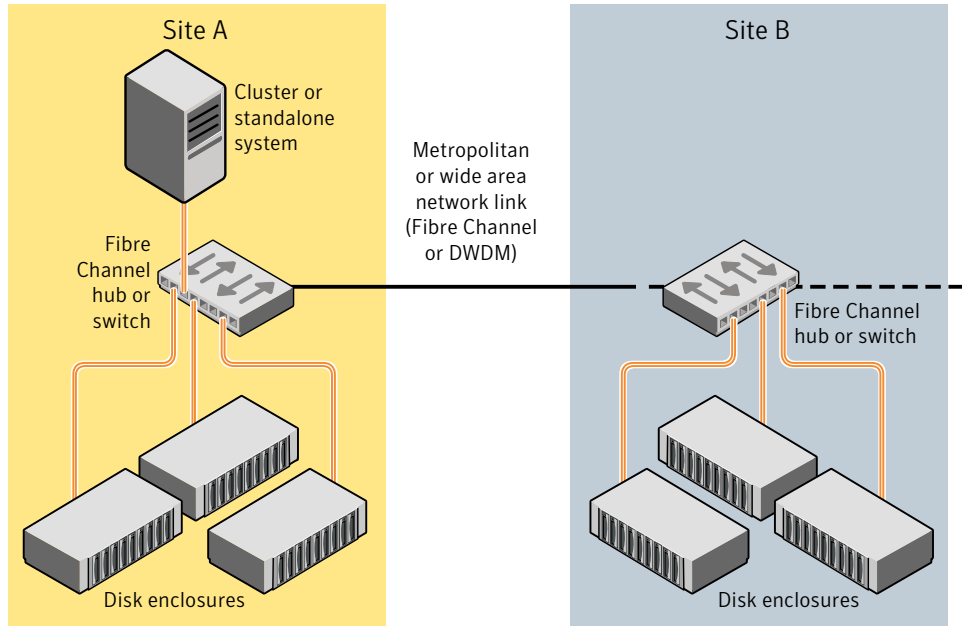

## About site-based allocation

Site-based allocation policies are enforced by default in a site-configured disk group. Site-based allocation requires that each volume has at least one plex at each site that is configured in the disk group. When a new volume is created in a site-configured disk group, the `allsites` attribute is set to `on`, by default. The `allsites` attribute indicates that the volume must have at least one plex on each configured site in the disk group. For new volumes, the read policy is set to `siteread` by default.

If mirroring across sites is not required, or is not possible (as is the case for RAID-5 volumes), specify the `allsites=off` attribute to the `vxassist` command. If sites are configured in the disk group, a plex will always be confined to a site and will not span across sites. This enforcement cannot be overridden.

Before adding a new site to a disk group, be sure to meet the following requirements:

- Disks from the site being added (site tagged) are present or added to the disk group.
- Each existing volume with `allsites` set in the disk group must have at least one plex at the site being added. If this condition is not met, the command to



add the site to the disk group fails. If the `-f` option is specified, the command does not fail, but instead it sets the `allsites` attribute for the volume to `off`.

---

**Note:** By default, volumes created will be mirrored when sites are configured in a disk group. Initial synchronization occurs between mirrors. Depending on the size of the volume, synchronization may take a long time. If you do not need to perform an initial synchronization across mirrors, use `init=active` with the `vxassist` command.

---

## About site consistency

Site consistency means that at any point in time, the data at each site is consistent with the application for a given set of volumes. A site-consistent volume must have at least one plex, or mirror, on each configured site in the disk group. The site consistency is ensured by detaching a site when a site-consistent volume loses its last complete plex on that site. The site detach detaches all the plaxes on that site and also disallows further configuration updates to the configuration copies on that site. Turn on this behavior by setting the `siteconsistent` attribute to `on` on the desired volumes.

If you set the `siteconsistent` attribute to `off`, only the plex that fails is detached. The plaxes for the remaining volumes on that site are not detached.

The `siteconsistent` attribute is also present at the disk group level and can be used to turn on or off the site consistency functionality in the disk group boundary. In addition, if you turn on the `siteconsistent` attribute for a disk group, each new volume created in the disk group inherits the site consistency of the disk group, by default. Setting the `siteconsistent` attribute on a disk group does not affect `siteconsistent` attributes for existing volumes. You can also control the site consistency on individual volumes.

By default, a volume inherits the value that is set on its disk group.

By default, creating a site-consistent volume also creates an associated version 20 DCO volume, and enables Persistent FastResync on the volume. This allows faster recovery of the volume during the reattachment of a site.

Before setting site consistency on a disk group, be sure to meet the following requirements:

- A license enabling the Site Awareness feature must be installed on all the hosts in the Remote Mirror configuration.
- At least two sites must be configured in the disk group before site consistency is turned on.

- All the disks in a disk group must be registered to one of the sites before you can set the `siteconsistent` attribute on the disk group.

## About site tags

In a Remote Mirror configuration, each storage device in the disk group must be tagged with site information. The site tag indicates to which site the device is associated. VxVM provides a facility to tag VxVM-initialized disks with an arbitrary name-value pair. The tag name `site` is reserved by VxVM and is used to identify the site information of tagged disks. The command `vxdisk settag` can be used to tag multiple disks or all disks from an enclosure or disks from multiple enclosures. The tagging can be restricted to disks in a disk group by specifying the disk group with the command.

You can use automatic site tagging to assign site tags to disks when adding them to a disk group. When automatic site tagging is on, newly added disks or LUNs inherit the site tag from the site-enclosure mapping stored in the disk group. To use automatic site tagging, turn on automatic site tagging for a disk group, and then assign the site names to the enclosures in the disk group. Any disks or LUNs in that disk group inherit the tag from the enclosure to which they belong.

## About the site read policy

To enhance read performance, VxVM will service reads from the plexes at the local site where an application is running, if the `siteread` read policy is set on a volume. Writes are written to plexes at all sites. By tagging hosts with site information, VxVM identifies which hosts belong to which site. Reads initiated by a host from one site are then satisfied by disks which are tagged with the same site. Tagging hosts and disks with correct site information gives you maximum read performance when `siteread` read policy is used.

If a license enabling the Site Awareness feature is installed on all the hosts in the Remote Mirror configuration, the disk group is configured for site consistency with several sites enabled, and the `allsites=on` attribute is specified for a volume, the default read policy is `siteread`.

If the `siteread` policy is not set, use the following command to set the read policy to `siteread` policy on a volume:

```
# vxvol [-g diskgroup] rdpol siteread volume
```

This command has no effect if a site name has not been set for the host.

See [“Changing the read policy for mirrored volumes”](#) on page 371.

# Making an existing disk group site consistent

The site consistency feature requires that a license enabling the site awareness feature has been installed on all hosts at all sites that participate in the configuration.

## To make an existing disk group site consistent

- 1 Ensure that the disk group is updated to at least version 140, by running the `vxvg upgrade` command on it:

```
# vxvg upgrade diskgroup
```

- 2 On each host that can access the disk group, define the site name:

```
# vxdctl set site=sitename
```

- 3 Tag all the disks in the disk group with the appropriate site name:

```
# vxdisk [-g diskgroup] settag site=sitename disk1 disk2
```

Or, to tag all the disks in a specified enclosure, use the following command:

```
# vxdisk [-g diskgroup] settag site=sitename  
encl:encl_name
```

- 4 Use the `vxvg move` command to move any unsupported RAID-5 volumes to another disk group. Alternatively, use the `vxassist convert` commands to convert the volumes to a supported layout such as `mirror` or `mirror-stripe`. You can use the `site` and `mirror=site` storage allocation attribute to ensure that the plexes are created on the correct storage.
- 5 Use the `vxevac` command to ensure that the volumes have at least one plex at each site. You can use the `site` and `mirror=site` storage allocation attribute to ensure that the plexes are created on the correct storage.
- 6 Register a site record for each site with the disk group:

```
# vxvg -g diskgroup addsite sitename
```

- 7 Turn on site consistency for the disk group:

```
# vxvg -g diskgroup set siteconsistent=on
```

**Configuring a new disk group as a Remote Mirror configuration**

- 8 Turn on the `allsites` flag for the volume which requires data replication to each site:

```
# vxvol [-g diskgroup] set allsites=on volume
```

- 9 Turn on site consistency for each existing volume in the disk group for which site consistency is needed. You also need to attach `DCOV20` if it is not attached already. `DCOV20` is required to ensure that site detach and reattach are instantaneous.

See “[Preparing a volume for DRL and instant snapshots](#)” on page 360.

```
# vxvol [-g diskgroup] set siteconsistent=on volume ...
```

## Configuring a new disk group as a Remote Mirror configuration

---

**Note:** The Remote Mirror feature requires that a license enabling the Site Awareness feature has been installed on all hosts at all sites that participate in the configuration.

---

This section describes setting up a new disk group. To configure an existing disk group as a Remote Mirror configuration, additional steps may be required.

### Setting up a new disk group for a Remote Mirror configuration

- 1 Define the site name for each host that can access the disk group.

```
# vxdctl set site=sitename
```

The name that has been assigned to a site is stored in the `/etc/vx/volboot` file.

- 2 Create the disk group with storage from each site.
- 3 Register a site record to the disk group, for each site.

```
# vxdg -g diskgroup [-f] addsite sitename
```

- 4 Do one of the following:

- To tag all disks regardless of the disk group, do the following: Assign a site name to the disks or enclosures. You can set site tags at the disk level, or at the enclosure level. If you specify one or more enclosures,

the site tag applies to the disks in that enclosure that are within the disk group. Enter the following command:

```
# vxdisk [-g diskgroup] settag site=sitename \  
    disk disk1... |encl:encl_name encl:encl_name1...
```

where the disks can be specified either by the disk access name or the disk media name.

- To autotag new disks added to the disk group based on the enclosure to which they belong, perform the following steps in the order presented. These steps are limited to disks in a single group.
  - Set the `autotagging` policy to `on` for the disk group, if required. Automatic tagging is the default setting, so this step is only required if the autotagging policy was previously disabled. To turn on autotagging, enter the following command:

```
# vxdg [-g diskgroup] set autotagging=on
```

- Add site-enclosure mapping information to the diskgroup for each site-enclosure combination. Enter the following command:

```
# vxdg [-g diskgroup] settag encl:encl_name1 site=sitename1
```

As a result of this command, all disks of enclosure `encl_name1` in the specified disk group are tagged with site information.

- 5 Turn on the site consistency requirement for a disk group:

```
# vxdg -g diskgroup set siteconsistent=on
```

## Fire drill — testing the configuration

---

**Warning:** To avoid potential loss of service or data, it is recommended that you do not use these procedures on a live system.

---

After validating the consistency of the volumes and disk groups at your sites, you should validate the procedures that you will use in the event of the various possible types of failure. A fire drill lets you test that a site can be brought up cleanly during recovery from a disaster scenario such as site failure.

## Simulating site failure

To simulate the failure of a site, use the following command to detach all the devices at a specified site:

```
# vxdg -g diskgroup [-f] detachsite sitename
```

The `-f` option must be specified if any plexes configured on storage at the site are currently online.

After the site is detached, the application should run correctly on the available site. This step verifies that the primary site is fine. Continue the fire drill by verifying the secondary site.

## Verifying the secondary site

After detaching the site from primary site, verify whether the application starts correctly on a secondary site. The fire drill ensures that the application can run on the secondary if disaster strikes the primary site. These procedures assume that the application is running correctly before the fire drill operation begins.

To verify the secondary site, import the detached site on a different host using the following command:

```
# vxdg -o site=sitename import dname
```

Then start the application. If the application runs correctly on the secondary site, this step verifies the integrity of the secondary site.

## Recovery from simulated site failure

After verifying the data on the secondary for a simulated site failure, deport the disk group from the secondary site. Then reattach the site back to the primary host.

Use the following commands to reattach a site and recover the disk group:

```
# vxdg -g diskgroup [-o overridesb] reattachsite sitename  
# vxrecover -g diskgroup
```

It may be necessary to specify the `-o overridesb` option if a serial split-brain condition is indicated.

## Changing the site name

You can change the site name, or tag, that is used to identify each site in a Remote Mirror configuration. Renaming the site changes the site record in the disk group. The site name is also changed for all of the disks and enclosures that are tagged with the existing site name.

After you rename a site, you need to explicitly change the site name for each host that belongs to that site.

### To rename the site

- ◆ Specify the new site name as follows:

```
# vxdg [-g diskgroup] renamesite old_sitename new_sitename
```

## Resetting the site name for a host

If you rename a site, you need to explicitly set each host to refer to the new site name.

### To reset a site name for a host

- 1 Remove the site name from a host:

```
# vxdctl [-F] unset site
```

The `-F` option is required if any imported disk groups are registered to the site.

- 2 Set the new site name for the host.

```
# vxdctl set site=sitename
```

The name that has been assigned to a site is stored in the `/etc/vx/volboot` file.

## Administering the Remote Mirror configuration

After the Remote Mirror site is configured, refer to the following sections for additional tasks to maintain the configuration.

## Configuring site tagging for disks or enclosures

To set up a Remote Mirror configuration, specify to which site each storage device in the disk group belongs. Assign a site tag to one or more disks or enclosures. If

the disk or enclosure does not belong to a disk group, you must use this method to assign a site tag.

#### To tag disks or enclosures with a site name

- ◆ Assign a site name to one or more disks or enclosures, using the following command:

```
# vxdisk [-g diskgroup] settag site=sitename \  
    disk disk1...|encl:encl_name encl:encl_name1...
```

where the disks can be specified either by the disk access name or the disk media name.

#### To display the disks or enclosures registered to a site

- ◆ To check which disks or enclosures are registered to a site, use the following command:

```
# vxdisk [-g diskgroup] listtag
```

#### To remove the site tag from a disk or enclosure

- ◆ To remove the site tag from a disk or enclosure, use the following command:

```
# vxdisk rmtag site=sitename \  
    disk disk1...|encl:encl_name encl:encl_name1...
```

## Configuring automatic site tagging for a disk group

Configure automatic site tagging if you want disks or LUNs to inherit the tag from the enclosure. After you turn on automatic site tagging for a disk group, assign the site names to the enclosures in the disk group. Any disks or LUNs added to that disk group inherit the tag from the enclosure to which they belong.

#### To configure automatic site tagging for a disk group

- 1 Set the autotagging policy to **on** for the disk group. Automatic tagging is the default setting, so this step is only required if the autotagging policy was previously disabled.

To turn on autotagging, use the following command:

```
# vxdg [-g diskgroup] set autotagging=on
```

- 2 Assign the site name to an enclosure within the disk group, using the following command:

```
# vxdg [-g diskgroup] settag encl:encl_name site=sitename
```



**To list the site tags for a disk group**

- ◆ To list the site tags for a disk group, use the following command:

```
# vxdbg [-g diskgroup] listtag site=sitename
```

**To remove a site tag from an enclosure or a disk group**

- ◆ To remove a site tag from a disk group, use the following command:

```
# vxdbg [-g diskgroup] rmtag [encl:encl_name] site=sitename
```

## Configuring site consistency on a volume

To set the site consistency requirement when creating a volume, specify the `siteconsistent` attribute to the `vxassist` `make` command, for example:

```
# vxassist [-g diskgroup] make volume size \  
  nmirror=4 siteconsistent={on|off}
```

By default, a volume inherits the value that is set on its disk group.

By default, creating a site-consistent volume also creates an associated version 20 DCO volume, and enables Persistent FastResync on the volume. This allows faster recovery of the volume during the reattachment of a site.

To turn on the site consistency requirement for an existing volume, use the following form of the `vxvol` command:

```
# vxvol [-g diskgroup] set siteconsistent=on volume
```

To turn off the site consistency requirement for a volume, use the following command:

```
# vxvol [-g diskgroup] set siteconsistent=off volume
```

The `siteconsistent` attribute and the `allsites` attribute must be set to `off` for RAID-5 volumes in a site-consistent disk group.

## Examples of storage allocation by specifying sites

Table 14-1 shows examples of how to use sites with the `vxassist` command to allocate storage. These examples assume that the disk group, `ccdg`, has been enabled for site consistency with disks configured at two sites, `site1` and `site2`. Also, `ccdg01`, `ccdg02`, and `ccdg03` are dm names of disks tagged with site `site1`. `ccdg09`, `ccdg10`, and `ccdg11` are dm names of disks tagged with site `site2`.

**Table 14-1** Examples of storage allocation by specifying sites

Command	Description
<pre># vxassist -g ccdg make vol 2g \   nmirror=2</pre>	<p>Create a volume with one mirror at each site. The <code>nmirror</code> keyword is optional. If the <code>nmirror</code> keyword is specified, it must equal the number of sites.</p>
<pre># vxassist -g ccdg -o ordered \   make vol 2g \   layout=mirror-stripe ncol=3 \   ccdg01 ccdg02 ccdg03 ccdg09 \   ccdg10 ccdg11</pre>	<p>Create a mirrored-stripe volume specifying allocation order to validate redundancy across the sites. The named disks must be tagged with the appropriate site name, and there must be sufficient disks at each site to create the volume.</p>
<pre># vxassist -g ccdg make vol 2g \   nmirror=2 ccdg01 ccdg09</pre>	<p>Create a volume with one mirror on each of the named disks. The named disks must be tagged with the appropriate site name, and there must be sufficient disks at each site to create the volume.</p>
<pre># vxassist -g ccdg make vol 2g \   nmirror=2 siteconsistent=off \   allsites=off</pre>	<p>Create a mirrored volume that is not site consistent. Both mirrors can be allocated from any available storage in the disk group, but the storage for each mirror is confined to a single site.</p>
<pre># vxassist -g ccdg make vol 2g \   nmirror=2 site:site2 \   siteconsistent=off \   allsites=off</pre>	<p>Create a mirrored volume that is not site consistent. Both mirrors are allocated from any available storage in the disk group that is tagged as belonging to <code>site2</code>.</p>
<pre># vxassist -g ccdg make vol 2g \   nmirror=2 \!site:sitel \   siteconsistent=off \   allsites=off</pre>	<p>Create a mirrored volume that is not site consistent. Both mirrors are allocated from any available storage in the disk group that is tagged as not belonging to <code>site1</code>.</p> <p><b>Note:</b> The <code>!</code> character is a special character in some shells. This example shows how to escape it in a bash shell.</p>

**Table 14-1** Examples of storage allocation by specifying sites (*continued*)

Command	Description
<pre># vxassist -g ccdg mirror vol \ site:sitel</pre>	Add a mirror at a specified site. The command fails if there is insufficient storage available at the site. This command does not affect the <code>allsites</code> or <code>siteconsistent</code> of a volume.
<pre># vxassist -g ccdg remove \ mirror vol site:sitel</pre>	Remove a mirror from a volume at a specified site. If the volume has the <code>allsites</code> attribute set to <code>on</code> , the command fails if this would remove the last remaining plex at a site.
<pre># vxassist -g ccdg growto vol \ 4g</pre>	Grow a volume. Each mirror of a volume is grown using the same site storage to which it belongs. If there is not enough storage to grow a mirror on each site, the command fails.

## Displaying site information

### To display the site name for a host

- ◆ To determine to which site a host belongs, use the following command on the host:

```
# vxdctl list | grep siteid  
siteid: building1
```

### To display the disks or enclosures registered to a site

- ◆ To check which disks or enclosures are registered to a site, use the following command:

```
# vxdisk [-g diskgroup] listtag
```

### To display the setting for automatic site tagging for a disk group

- ◆ To determine whether automatic site tagging is on for a disk group, use the following command:

```
# vxprint -g diskgroup -F"%autotagging" diskgroup
```

**To verify whether site consistency has been enabled for a disk group**

- ◆ To verify whether site consistency has been enabled for a disk group, use the following command:

```
# vxdg list diskgroup | grep siteconsistent
flags: siteconsistent
```

**To verify whether site consistency has been enabled for a volume**

- ◆ To verify whether site consistency has been enabled for a volume, use the following command:

```
# vxprint -g diskgroup -F"%siteconsistent" vol
```

**To identify which site a plex or mirror is allocated from**

- ◆ To identify which site a plex or mirror is allocated from, use the following command:

```
# vxprint -g diskgroup -F"%site" plex
```

**To list the site tags for a disk group**

- ◆ To list the site tags for a disk group, use the following command:

```
# vxdg [-g diskgroup] listtag site=sitename
```

## Failure and recovery scenarios

[Table 14-2](#) lists the possible failure scenarios and recovery procedures for the Remote Mirror feature.

**Table 14-2** Failure scenarios and recovery procedures

Failure scenario	Recovery procedure
Disruption of network link between sites.	See <a href="#">“Recovering from a loss of site connectivity”</a> on page 541.
Failure of hosts at a site.	See <a href="#">“Recovering from host failure”</a> on page 541.
Failure of storage at a site.	See <a href="#">“Recovering from storage failure”</a> on page 541.
Failure of both hosts and storage at a site.	See <a href="#">“Recovering from site failure”</a> on page 542.

## Recovering from a loss of site connectivity

---

**Warning:** To avoid a potential loss of data, it is recommended that you configure Veritas Cluster Server to handle network split-brain.

---

If the network links between the sites are disrupted, the application environments may continue to run in parallel, and this may lead to inconsistencies between the disk group configuration copies at the sites. If the parallel instances of an application issue writes to volumes, an unrecoverable data loss may occur and manual intervention is needed. To avoid data loss, it is recommended that you configure the VCS fencing mechanism to handle network split-brain situations. When connectivity between the sites is restored, a serial split-brain condition will be detected between the sites. One site must be chosen as having the preferred version of the data and the disk group configuration copies. The data from the chosen site is resynchronized to other the site. If new writes are issued to volumes after the network split, they are overwritten with the data from the chosen site. The configuration copies at the other sites are updated from the copies at the chosen site.

At the chosen site, use the following commands to reattach a site and recover the disk group:

```
# vxdg -g diskgroup -o overridesb reattachsite sitename  
# vxrecover -g diskgroup
```

In the case that the host systems are configured at a single site with only storage at the remote sites, the usual resynchronization mechanism of VxVM is used to recover the remote plexes when the storage comes back on line.

See [“Handling conflicting configuration copies”](#) on page 250.

## Recovering from host failure

If one or more cluster nodes fail at a site, but the storage remains online, this is handled either by VCS failover in the case of the Storage Foundation HA product, or by node takeover in the case that the node was the master for a shared disk group as supported by the Storage Foundation Cluster File System software.

## Recovering from storage failure

If storage fails at a site, the plexes that are configured on that storage are detached locally if a site-consistent volume still has other mirrors available at the site. The hot-relocation feature of VxVM will attempt to recreate the failed plexes on other available storage in the disk group. If no plexes of a site-consistent volume remain

in operation at a site, and hot-relocation cannot recreate the plexes at that site, the site is detached. Because site connectivity has not been lost, applications running on hosts at the site can still access data at the other sites.

When the storage comes back online, the `vxattachd` reattaches the site automatically.

See [“Automatic site reattachment”](#) on page 542.

If the `vxattachd` is not running, use the following commands to reattach a site and recover the disk group:

```
# vxdg -g diskgroup reattachsite sitename
# vxrecover -g diskgroup
```

For more information about recovering a disk group, refer to the *Veritas Volume Manager Troubleshooting Guide*.

## Recovering from site failure

If all the hosts and storage fail at a site, use the following commands to reattach the site after it comes back online, and to recover the disk group:

```
# vxdg -g diskgroup [-o overridesb] reattachsite sitename
# vxrecover -g diskgroup
```

The `-o overridesb` option is only required if a serial split-brain condition is indicated. A serial split-brain condition may happen if the site was brought back up while the private network link was inoperative. This option updates the configuration database on the reattached site with the consistent copies at the other sites.

See [“Handling conflicting configuration copies”](#) on page 250.

For more information about recovering a disk group, refer to the *Veritas Volume Manager Troubleshooting Guide*.

## Automatic site reattachment

The automatic site reattachment daemon, `vxattachd`, provides automatic reattachment of sites. The `vxattachd` daemon uses the `vxnotify` mechanism to monitor storage coming back online on a site after a previous failure, and to restore redundancy of mirrors across sites.

If the hot-relocation daemon, `vxrelocd`, is running, `vxattachd` attempts to reattach the site, and allows `vxrelocd` to try to use the available disks in the disk group to relocate the failed subdisks. If `vxrelocd` succeeds in relocating the failed subdisks,

it starts the recovery of the plexes at the site. When all the plexes have been recovered, the plexes are put into the ACTIVE state, and the state of the site is set to ACTIVE.

If `vxrelocd` is not running, `vxattachd` reattaches a site only when all the disks at that site become accessible. After reattachment succeeds, `vxattachd` sets the site state to ACTIVE, and initiates recovery of the plexes. When all the plexes have been recovered, the plexes are put into the ACTIVE state.

---

**Note:** `vxattachd` does not try to reattach a site that you have explicitly detached by using the `vxdbg detachsite` command.

---

The automatic site reattachment feature is enabled by default. The `vxattachd` daemon uses email to notify `root` of any attempts to reattach sites and to initiate recovery of plexes at those sites.

To send mail to other users, add the user name to the line that starts `vxattachd` in the `/lib/svc/method/vxvm-recover` startup script and run the `svcadm refresh vxvm/vxvm-recover` command (for Solaris 10 onward), or `/etc/init.d/vxvm-recover` and reboot the system (for OS releases before Solaris 10).

If you do not want a site to be recovered automatically, kill the `vxattachd` daemon, and prevent it from restarting. If you stop `vxattachd`, the automatic plex reattachment also stops. To kill the daemon, run the following command from the command line:

```
# ps -afe
```

Locate the process table entry for `vxattachd`, and kill it by specifying its process ID:

```
# kill -9 PID
```

If there is no entry in the process table for `vxattachd`, the automatic site reattachment feature is disabled.

To prevent the automatic site reattachment feature from being restarted, comment out the line that starts `vxattachd` in the `/lib/svc/method/vxvm-recover` startup script and run the `svcadm refresh vxvm/vxvm-recover` command (for Solaris 10 onward), or `/etc/init.d/vxvm-recover` (for OS releases before Solaris 10).





# Performance monitoring and tuning

This chapter includes the following topics:

- [Performance guidelines](#)
- [RAID-5](#)
- [Performance monitoring](#)
- [Tuning VxVM](#)

## Performance guidelines

Veritas Volume Manager (VxVM) can improve system performance by optimizing the layout of data storage on the available hardware. VxVM lets you optimize data storage performance using the following strategies:

- Balance the I/O load among the available disk drives.
- Use striping and mirroring to increase I/O bandwidth to the most frequently accessed data.

VxVM also provides data redundancy through mirroring and RAID-5, which allows continuous access to data in the event of disk failure.

## Data assignment

When you decide where to locate file systems, you typically try to balance I/O load among the available disk drives. The effectiveness of this approach is limited. It is difficult to predict future usage patterns, and you cannot split file systems across the drives. For example, if a single file system receives the most disk accesses, moving the file system to another drive also moves the bottleneck.

VxVM can split volumes across multiple drives. This approach gives you a finer level of granularity when you locate data. After you measure access patterns, you can adjust your decisions on where to place file systems. You can reconfigure volumes online without adversely impacting their availability.

## Striping

Striping improves access performance by cutting data into slices and storing it on multiple devices that can be accessed in parallel. Striped plexes improve access performance for both read and write operations.

After you identify the most heavily-accessed volumes (containing file systems or databases), you can increase access bandwidth to this data by striping it across portions of multiple disks.

Figure 15-1 shows an example of a single volume (`HotVol`) that has been identified as a data-access bottleneck.

Figure 15-1 Use of striping for optimal data access

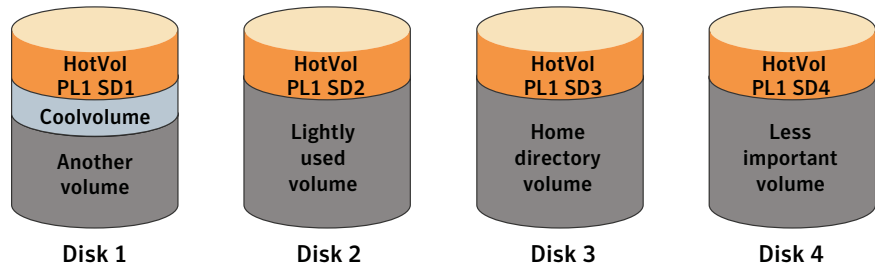

This volume is striped across four disks. The remaining space on these disks is free for use by less-heavily used volumes.

## Mirroring

Mirroring stores multiple copies of data on a system. When you apply mirroring properly, data is continuously available. Mirroring also protects against data loss due to physical media failure. If the system crashes or a disk or other hardware fails, mirroring improves the chance of data recovery.

In some cases, you can also use mirroring to improve I/O performance. Unlike striping, the performance gain depends on the ratio of reads to writes in the disk accesses. If the system workload is primarily write-intensive (for example, greater than 30 percent writes), mirroring can reduce performance.

## Combining mirroring and striping

When you have multiple I/O streams, you can use mirroring and striping together to significantly improve performance.

Because parallel I/O streams can operate concurrently on separate devices, striping provides better throughput. When I/O fits exactly across all stripe units in one stripe, serial access is optimized.

Because mirroring is generally used to protect against loss of data due to disk failures, it is often applied to write-intensive workloads. This approach degrades throughput. In those cases, you can combine mirroring with striping to deliver high availability and increased throughput.

You can create a mirrored-stripe volume. Stripe half of the available disks to form one striped data plex, and stripe the remaining disks to form the other striped data plex in the mirror. This approach is often the best way to configure a set of disks for optimal performance with reasonable reliability. However, if a disk in one of the plexes fails, the entire plex is unavailable.

You can also arrange equal numbers of disks into separate mirror volumes. Afterwards, create a striped plex across these mirror volumes to form a striped-mirror volume.

See [“Mirroring plus striping \(striped-mirror, RAID-1+0 or RAID-10\)”](#) on page 45.

If a disk in a mirror fails, it does not take the disks in the other mirrors out of use. For large volumes or large numbers of disks, a striped-mirror layout is preferred over a mirrored-stripe layout.

## RAID-5

RAID-5 offers many of the advantages of combined mirroring and striping, but it requires more disk space. RAID-5 read performance is similar to that of striping, and RAID-5 parity offers redundancy similar to mirroring. The disadvantages of RAID-5 include relatively slow write performance.

RAID-5 is not usually seen as a way to improve throughput performance. The exception is when the access patterns of applications show a high ratio of reads to writes. .

## Volume read policies

To help optimize performance for different types of volumes, VxVM lets you set one of several read policies on data plexes.

See [“Changing the read policy for mirrored volumes”](#) on page 371.

Figure 15-2 shows an example in which the read policy of the mirrored-stripe volume labeled `Hot Vol` is set to `prefer` for the striped plex `PL1`.

Figure 15-2 Use of mirroring and striping for improved performance

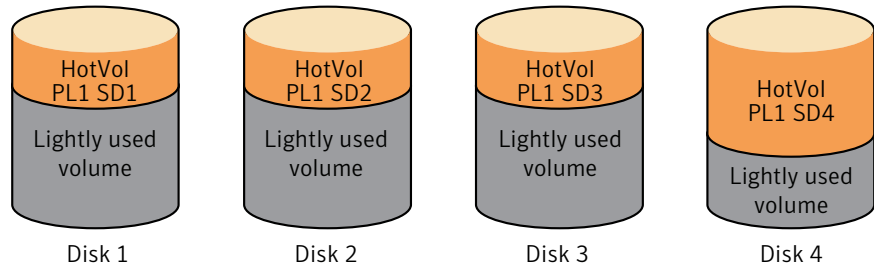

The `prefer` policy distributes the load when reading across the otherwise lightly-used disks in `PL1`, as opposed to the single disk in `plex PL2`. (`HotVol` is an example of a mirrored-stripe volume in which one data plex is striped and the other data plex is concatenated.)

To improve performance for read-intensive workloads, you can attach up to 32 data plexes to the same volume. However, this approach is usually an ineffective use of disk space for the gain in read performance.

## Performance monitoring

As a system administrator, you have two sets of priorities for setting priorities for performance. One set is physical, concerned with hardware such as disks and controllers. The other set is logical, concerned with managing software and its operation.

### Setting performance priorities

The important physical performance characteristics of disk hardware are the relative amounts of I/O on each drive, and the concentration of the I/O within a drive to minimize seek time. Based on monitored results, you can then move the location of subdisks to balance I/O activity across the disks.

The logical priorities involve software operations and how they are managed. Based on monitoring, you may choose to change the layout of certain volumes to improve their performance. You might even choose to reduce overall throughput to improve the performance of certain critical volumes. Only you can decide what is important on your system and what trade-offs you need to make.

Best performance is usually achieved by striping and mirroring all volumes across a reasonable number of disks and mirroring between controllers, when possible. This procedure tends to even out the load between all disks, but it can make VxVM more difficult to administer. For large numbers of disks (hundreds or thousands), set up disk groups containing 10 disks, where each group is used to create a striped-mirror volume. This technique provides good performance while easing the task of administration.

## Obtaining performance data

VxVM provides two types of performance information: I/O statistics and I/O traces. Each of these can help in performance monitoring. You can obtain I/O statistics using the `vxstat` command, and I/O traces using the `vxtrace` command. A brief discussion of each of these utilities may be found in the following sections.

### Tracing volume operations

Use the `vxtrace` command to trace operations on specified volumes, kernel I/O object types or devices. The `vxtrace` command either prints kernel I/O errors or I/O trace records to the standard output or writes the records to a file in binary format. Binary trace records written to a file can also be read back and formatted by `vxtrace`.

If you do not specify any operands, `vxtrace` reports either all error trace data or all I/O trace data on all virtual disk devices. With error trace data, you can select all accumulated error trace data, wait for new error trace data, or both of these (this is the default action). Selection can be limited to a specific disk group, to specific VxVM kernel I/O object types, or to particular named objects or devices.

See the `vxtrace(1M)` manual page.

### Printing volume statistics

Use the `vxstat` command to access information about activity on volumes, plexes, subdisks, and disks under VxVM control, and to print summary statistics to the standard output. These statistics represent VxVM activity from the time the system initially booted or from the last time the counters were reset to zero. If no VxVM object name is specified, statistics from all volumes in the configuration database are reported.

VxVM records the following I/O statistics:

- count of operations
- number of blocks transferred (one operation can involve more than one block)

- average operation time (which reflects the total time through the VxVM interface and is not suitable for comparison against other statistics programs)

These statistics are recorded for logical I/O including reads, writes, atomic copies, verified reads, verified writes, plex reads, and plex writes for each volume. As a result, one write to a two-plex volume results in at least five operations: one for each plex, one for each subdisk, and one for the volume. Also, one read that spans two subdisks shows at least four reads—one read for each subdisk, one for the plex, and one for the volume.

VxVM also maintains other statistical data. For each plex, it records read and write failures. For volumes, it records corrected read and write failures in addition to read and write failures.

To reset the statistics information to zero, use the `-r` option. This can be done for all objects or for only those objects that are specified. Resetting just prior to an operation makes it possible to measure the impact of that particular operation.

The following is an example of output produced using the `vxstat` command:

TYP	NAME	OPERATIONS		BLOCKS		AVG TIME (ms)	
		READ	WRITE	READ	WRITE	READ	WRITE
vol	blp	0	0	0	0	0.0	0.0
vol	foobarvol	0	0	0	0	0.0	0.0
vol	rootvol	73017	181735	718528	1114227	26.8	27.9
vol	swapvol	13197	20252	105569	162009	25.8	397.0
vol	testvol	0	0	0	0	0.0	0.0

Additional volume statistics are available for RAID-5 configurations.

See the `vxstat(1M)` manual page.

## Using performance data

When you have gathered performance data, you can use it to determine how to configure your system to use resources most effectively. The following sections provide an overview of how you can use this data.

### Using I/O statistics

Examination of the I/O statistics can suggest how to reconfigure your system. You should examine two primary statistics: volume I/O activity and disk I/O activity.

Before obtaining statistics, reset the counters for all existing statistics using the `vxstat -r` command. This eliminates any differences between volumes or disks

due to volumes being created, and also removes statistics from boot time (which are not usually of interest).

After resetting the counters, allow the system to run during typical system activity. Run the application or workload of interest on the system to measure its effect. When monitoring a system that is used for multiple purposes, try not to exercise any one application more than usual. When monitoring a time-sharing system with many users, let statistics accumulate for several hours during the normal working day.

To display volume statistics, enter the `vxstat` command with no arguments. The following is a typical display of volume statistics:

TYP	NAME	OPERATIONS		BLOCKS		AVG TIME (ms)	
		READ	WRITE	READ	WRITE	READ	WRITE
vol	archive	865	807	5722	3809	32.5	24.0
vol	home	2980	5287	6504	10550	37.7	221.1
vol	local	49477	49230	507892	204975	28.5	33.5
vol	rootvol	102906	342664	1085520	1962946	28.1	25.6
vol	src	79174	23603	425472	139302	22.4	30.9
vol	swapvol	22751	32364	182001	258905	25.3	323.2

Such output helps to identify volumes with an unusually large number of operations or excessive read or write times.

To display disk statistics, use the `vxstat -d` command. The following is a typical display of disk statistics:

TYP	NAME	OPERATIONS		BLOCKS		AVG TIME (ms)	
		READ	WRITE	READ	WRITE	READ	WRITE
dm	mydg01	40473	174045	455898	951379	29.5	35.4
dm	mydg02	32668	16873	470337	351351	35.2	102.9
dm	mydg03	55249	60043	780779	731979	35.3	61.2
dm	mydg04	11909	13745	114508	128605	25.0	30.7

If you need to move the volume named `archive` onto another disk, use the following command to identify on which disks it lies:

```
# vxprint -g mydg -tvh archive
```

The following is an extract from typical output:

V	NAME	RVG/VSET/CO	KSTATE	STATE	LENGTH	READPOL	REFPLEX	UTYPE
PL	NAME	VOLUME	KSTATE	STATE	LENGTH	LAYOUT	NCOL/WDTH	MODE
SD	NAME	PLEX	DISK	DISKOFFS	LENGTH	[COL/]OFF	DEVICE	MODE
v	archive	-	ENABLED	ACTIVE	20480	SELECT	-	fsgen

pl	archive-01	archive	ENABLED	ACTIVE	20480	CONCAT	-	RW
sd	mydg03-03	archive-01	mydg03	0	40960	0	c1t2d0	ENA

The subdisks line (beginning `sd`) indicates that the volume `archive` is on disk `mydg03`. To move the volume off `mydg03`, use the following command.

---

**Note:** The `!` character is a special character in some shells. This example shows how to escape it in a `bash` shell.

---

```
# vxassist -g mydg move archive \!mydg03 dest_disk
```

Here `dest_disk` is the destination disk to which you want to move the volume. It is not necessary to specify a destination disk. If you do not specify a destination disk, the volume is moved to an available disk with enough space to contain the volume.

For example, to move a volume from disk `mydg03` to disk `mydg04`, in the disk group, `mydg`, use the following command:

```
# vxassist -g mydg move archive \!mydg03 mydg04
```

This command indicates that the volume is to be reorganized so that no part of it remains on `mydg03`.

Storage Foundation Manager has a graphical user interface (GUI), which provides an easier way to move pieces of volumes between disks. You may find that approach preferable to using the command line.

If two volumes (other than the root volume) on the same disk are busy, move them so that each is on a different disk.

If one volume is particularly busy (especially if it has unusually large average read or write times), stripe the volume (or split the volume into multiple pieces, with each piece on a different disk). If done online, converting a volume to use striping requires sufficient free space to store an extra copy of the volume. If sufficient free space is not available, a backup copy can be made instead. To convert a volume, create a striped plex as a mirror of the volume and then remove the old plex. For example, the following commands stripe the volume `archive` across disks `mydg02`, `mydg03`, and `mydg04` in the disk group, `mydg`, and then remove the original plex `archive-01`:

```
# vxassist -g mydg mirror archive layout=stripe mydg02 mydg03 \
  mydg04
# vxplex -g mydg -o rm dis archive-01
```



After reorganizing any particularly busy volumes, check the disk statistics. If some volumes have been reorganized, clear statistics first and then accumulate statistics for a reasonable period of time.

If some disks appear to be excessively busy (or have particularly long read or write times), you may want to reconfigure some volumes. If there are two relatively busy volumes on a disk, move them closer together to reduce seek times on the disk. If there are too many relatively busy volumes on one disk, move them to a disk that is less busy.

Use I/O tracing (or subdisk statistics) to determine whether volumes have excessive activity in particular regions of the volume. If the active regions can be identified, split the subdisks in the volume and move those regions to a less busy disk.

---

**Warning:** Striping a volume, or splitting a volume across multiple disks, increases the chance that a disk failure results in failure of that volume. For example, if five volumes are striped across the same five disks, then failure of any one of the five disks requires that all five volumes be restored from a backup. If each volume were on a separate disk, only one volume would need to be restored. Use mirroring or RAID-5 to reduce the chance that a single disk failure results in failure of a large number of volumes.

---

Note that file systems and databases typically shift their use of allocated space over time, so this position-specific information on a volume is often not useful. Databases are reasonable candidates for moving to non-busy disks if the space used by a particularly busy index or table can be identified.

Examining the ratio of reads to writes helps to identify volumes that can be mirrored to improve their performance. If the read-to-write ratio is high, mirroring can increase performance as well as reliability. The ratio of reads to writes where mirroring can improve performance depends greatly on the disks, the disk controller, whether multiple controllers can be used, and the speed of the system bus. If a particularly busy volume has a high ratio of reads to writes, it is likely that mirroring can significantly improve performance of that volume.

## Using I/O tracing

I/O statistics provide the data for basic performance analysis; I/O traces serve for more detailed analysis. With an I/O trace, focus is narrowed to obtain an event trace for a specific workload. This helps to explicitly identify the location and size of a hot spot, as well as which application is causing it.

Using data from I/O traces, real work loads on disks can be simulated and the results traced. By using these statistics, you can anticipate system limitations and plan for additional resources.

See [“Gathering and displaying I/O statistics”](#) on page 191.

See [“Specifying the I/O policy”](#) on page 200.

## Tuning VxVM

This section describes how to adjust the tunable parameters that control the system resources that are used by VxVM. Depending on the system resources that are available, adjustments may be required to the values of some tunable parameters to optimize performance.

### General tuning guidelines

VxVM is optimally tuned for most configurations ranging from small systems to larger servers. When you can use tuning to increase performance on larger systems at the expense of a valuable resource (such as memory), VxVM is generally tuned to run on the smallest supported configuration. You must perform any tuning changes with care. Changes may adversely affect overall system performance or may even leave VxVM unusable.

Various mechanisms exist for tuning VxVM. You can tune many parameters by editing the file `/kernel/drv/vxio.conf` to override the default values set by the `vxio` driver. Other values can only be tuned using the command line interface to VxVM.

See [“Changing the values of tunables”](#) on page 555.

### Tuning guidelines for large systems

On smaller systems (with fewer than a hundred disk drives), tuning is unnecessary. VxVM can adopt reasonable defaults for all configuration parameters. On larger systems, configurations can require additional control over the tuning of these parameters, both for capacity and performance reasons.

Generally, only a few significant decisions must be made when setting up VxVM on a large system. One is to decide on the size of the disk groups and the number of configuration copies to maintain for each disk group. Another is to choose the size of the private region for all the disks in a disk group.

Larger disk groups have the advantage of providing a larger free-space pool for the `vxassist` command to select from. They also allow for the creation of larger volumes. Smaller disk groups do not require as large a configuration database and so can exist with smaller private regions. Very large disk groups can eventually exhaust the private region size in the disk group. The result is that no more configuration objects can be added to that disk group. At that point, the

configuration either has to be split into multiple disk groups, or the private regions have to be enlarged. Each disk in the disk group must be re-initialized. This can involve reconfiguring everything and restoring from backup.

## Number of configuration copies for a disk group

Selection of the number of configuration copies for a disk group is based on a trade-off between redundancy and performance. As a general rule, reducing the number of configuration copies in a disk group speeds up initial access of the disk group, initial startup of the `vxconfigd` daemon, and transactions that are performed within the disk group. However, reducing the number of configuration copies also increases the risk of complete loss of the configuration database, which results in the loss of all objects in the database and of all data in the disk group.

The default policy for configuration copies in the disk group is to allocate a configuration copy for each controller identified in the disk group, or for each target that contains multiple addressable disks. This provides a sufficient degree of redundancy, but can lead to a large number of configuration copies under some circumstances. If this is the case, we recommended that you limit the number of configuration copies to a maximum of 4. Distribute the copies across separate controllers or targets to enhance the effectiveness of this redundancy.

To set the number of configuration copies for a new disk group, use the `nconfig` operand with the `vx dg init` command.

See the `vx dg(1M)` manual page for details.

You can also change the number of copies for an existing group by using the `vxedit set` command. For example, to configure five configuration copies for the disk group, `bigdg`, use the following command:

```
# vxedit set nconfig=5 bigdg
```

See the `vxedit(1M)` manual page.

## Changing the values of tunables

Tunables can be modified by editing the file `/kernel/drv/vxio.conf` for most VxVM kernel tunables. The system must be shut down and rebooted for the change to take effect.

---

**Warning:** If you modify `/kernel/drv/vxio.conf`, make a backup copy of the file.

---

For example, a single entry has been added to the end of the following `/kernel/drv/vxio.conf` file to change the value of `vol_tunable` to 5000:

```
name="vxio" parent="pseudo" instance=0 vol_tunable=5000;
```

---

**Warning:** Do not edit the configuration file for the `vxspec` driver, `/kernel/drv/vxspec.conf`.

---

You can use the `prtconf -vP` command to display the current values of the tunables. All VxVM tunables that you specify in `/kernel/drv/vxio.conf` are listed in the output under the “System properties.” heading for the `vxio` drivers. All unchanged tunables are listed with their default values under the “Driver properties” heading. The following sample output shows the new value for `vol_tunable` in hexadecimal:

```
# prtconf -vP
.
.
.
vxio, instance #0
  System properties:
    name <vol_tunable> length <4>
    value <0x00001388>
  Driver properties:
    name <voldrl_max_seq_dirty> length <4>
    value <0x00000003>
.
.
.
```

For more information, see the `prtconf(1M)` and `driver.conf(4)` manual pages.

DMP tunables are set online (without requiring a reboot) by using the `vxdkmpadm` command as shown here:

```
# vxdkmpadm settune dmp_tunable=value
```

The values of these tunables can be displayed by using this command:

```
# vxdkmpadm gettune [dmp_tunable]
```

## Tunable parameters for VxVM

[Table 15-1](#) lists the kernel tunable parameters for VxVM.

**Table 15-1** Kernel tunable parameters for VxVM

Parameter	Description
<code>vol_checkpoint_default</code>	<p>The interval at which utilities performing recoveries or resynchronization operations load the current offset into the kernel as a checkpoint. A system failure during such operations does not require a full recovery, but can continue from the last reached checkpoint.</p> <p>The default value is 20480 sectors (10MB).</p> <p>Increasing this size reduces the overhead of checkpoints on recovery operations at the expense of additional recovery following a system failure during a recovery.</p>
<code>vol_default_iodelay</code>	<p>The count in clock ticks for which utilities pause if they have been directed to reduce the frequency of issuing I/O requests, but have not been given a specific delay time. This tunable is used by utilities performing operations such as resynchronizing mirrors or rebuilding RAID-5 columns.</p> <p>The default value is 50 ticks.</p> <p>Increasing this value results in slower recovery operations and consequently lower system impact while recoveries are being performed.</p>

**Table 15-1** Kernel tunable parameters for VxVM (*continued*)

Parameter	Description
vol_fmnr_logsz	<p>The maximum size in kilobytes of the bitmap that Non-Persistent FastResync uses to track changed blocks in a volume. The number of blocks in a volume that are mapped to each bit in the bitmap depends on the size of the volume, and this value changes if the size of the volume is changed.</p> <p>For example, if the volume size is 1 gigabyte and the system block size is 512 bytes, a value for this tunable of 4 yields a map that contains 32,768 bits, each bit representing one region of 64 blocks.</p> <p>The larger the bitmap size, the fewer the number of blocks that are mapped to each bit. This can reduce the amount of reading and writing required on resynchronization, at the expense of requiring more non-pageable kernel memory for the bitmap. Additionally, on clustered systems, a larger bitmap size increases the latency in I/O performance, and it also increases the load on the private network between the cluster members. This is because every other member of the cluster must be informed each time a bit in the map is marked.</p> <p>Since the region size must be the same on all nodes in a cluster for a shared volume, the value of this tunable on the master node overrides the tunable values on the slave nodes, if these values are different. Because the value of a shared volume can change, the value of this tunable is retained for the life of the volume.</p> <p>In configurations which have thousands of mirrors with attached snapshot plexes, the total memory overhead can represent a significantly higher overhead in memory consumption than is usual for VxVM.</p> <p>The default value is 4KB. The maximum and minimum permitted values are 1KB and 8KB.</p> <p><b>Note:</b> The value of this tunable does not have any effect on Persistent FastResync.</p>

**Table 15-1** Kernel tunable parameters for VxVM (*continued*)

Parameter	Description
<code>vol_kmsg_resend_period</code>	This is an obsolete tunable parameter. Use <code>vol_kmsg_resend_period_usecs</code> instead. If specified in <code>/kernel/drv/vxio.conf</code> , the value is internally converted to microseconds, and applied to <code>vol_kmsg_resend_period_usecs</code> instead.
<code>vol_kmsg_resend_period_usecs</code>	The value in microseconds of the kernel message (KMSG) resend period that is used by the clustering functionality of VxVM .  The default value is 3000000 microseconds (3 seconds).  This tunable should be used instead of <code>vol_kmsg_resend_period</code> from release 5.0 onward as it allows finer granularity to be applied to performance tuning.
<code>vol_kmsg_send_period</code>	This is an obsolete tunable parameter. Use <code>vol_kmsg_send_period_usecs</code> instead. If specified in <code>/kernel/drv/vxio.conf</code> , the value is internally converted to microseconds, and applied to <code>vol_kmsg_send_period_usecs</code> instead.
<code>vol_kmsg_send_period_usecs</code>	The value in microseconds of the kernel message (KMSG) send period that is used by the clustering functionality of VxVM with SunCluster. The default value is 1000000 microseconds (1 second). This tunable should be used instead of <code>vol_kmsg_send_period</code> from release 5.0 onward as it allows finer granularity to be applied to performance tuning.
<code>vol_max_vol</code>	The maximum number of volumes that can be created on the system. The minimum and maximum permitted values are 1 and the maximum number of minor numbers representable on the system.  The default value is 131071.

**Table 15-1** Kernel tunable parameters for VxVM (*continued*)

Parameter	Description
<code>vol_maxio</code>	<p>The maximum size of logical I/O operations that can be performed without breaking up the request. I/O requests to VxVM that are larger than this value are broken up and performed synchronously. Physical I/O requests are broken up based on the capabilities of the disk device and are unaffected by changes to this maximum logical request limit.</p> <p>The default value is 2048 sectors (1MB).</p> <p>The value of <code>voliomem_maxpool_sz</code> must be at least 10 times greater than the value of <code>vol_maxio</code>.</p> <p>If DRL sequential logging is configured, the value of <code>voldrl_min_regionsz</code> must be set to at least half the value of <code>vol_maxio</code>.</p>
<code>vol_maxioctl</code>	<p>The maximum size of data that can be passed into VxVM via an <code>ioctl</code> call. Increasing this limit allows larger operations to be performed. Decreasing the limit is not generally recommended, because some utilities depend upon performing operations of a certain size and can fail unexpectedly if they issue oversized <code>ioctl</code> requests.</p> <p>The default value is 32768 bytes (32KB).</p>
<code>vol_maxparallelio</code>	<p>The number of I/O operations that the <code>vxconfigd</code> daemon is permitted to request from the kernel in a single <code>VOL_VOLDIO_READ</code> per <code>VOL_VOLDIO_WRITE</code> <code>ioctl</code> call.</p> <p>The default value is 256. This value should not be changed.</p>



**Table 15-1** Kernel tunable parameters for VxVM (*continued*)

Parameter	Description
vol_maxspecialio	<p>The maximum size of an I/O request that can be issued by an <code>ioctl</code> call. Although the <code>ioctl</code> request itself can be small, it can request a large I/O request be performed. This tunable limits the size of these I/O requests. If necessary, a request that exceeds this value can be failed, or the request can be broken up and performed synchronously.</p> <p>The default value is 4096 sectors (2MB).</p> <p>Raising this limit can cause difficulties if the size of an I/O request causes the process to take more memory or kernel virtual mapping space than exists and thus deadlock. The maximum limit for this tunable is 20% of the smaller of physical memory or kernel virtual memory. It is inadvisable to go over this limit, because deadlock is likely to occur.</p> <p>If stripes are larger than the value of this tunable, full stripe I/O requests are broken up, which prevents full-stripe read/writes. This throttles the volume I/O throughput for sequential I/O or larger I/O requests.</p> <p>This tunable limits the size of an I/O request at a higher level in VxVM than the level of an individual disk. For example, for an 8 by 64KB stripe, a value of 256KB only allows I/O requests that use half the disks in the stripe; thus, it cuts potential throughput in half. If you have more columns or you have used a larger interleave factor, then your relative performance is worse.</p> <p>This tunable must be set, as a minimum, to the size of your largest stripe (RAID-0 or RAID-5).</p>
vol_subdisk_num	<p>The maximum number of subdisks that can be attached to a single plex. There is no theoretical limit to this number, but it has been limited to a default value of 4096. This default can be changed, if required.</p>
volcvm_smartsync	<p>If set to 0, <code>volcvm_smartsync</code> disables SmartSync on shared disk groups. If set to 1, this parameter enables the use of SmartSync with shared disk groups.</p> <p>See <a href="#">“SmartSync recovery accelerator”</a> on page 60.</p>

**Table 15-1** Kernel tunable parameters for VxVM (*continued*)

Parameter	Description
voldrl_max_drtregs	<p>The maximum number of dirty regions that can exist on the system for non-sequential DRL on volumes. A larger value may result in improved system performance at the expense of recovery time. This tunable can be used to regulate the worse-case recovery time for the system following a failure.</p> <p>The default value is 2048.</p>
voldrl_max_seq_dirty	<p>The maximum number of dirty regions allowed for sequential DRL. This is useful for volumes that are usually written to sequentially, such as database logs. Limiting the number of dirty regions allows for faster recovery if a crash occurs.</p> <p>The default value is 3.</p>
voldrl_min_regionsz	<p>The minimum number of sectors for a dirty region logging (DRL) volume region. With DRL, VxVM logically divides a volume into a set of consecutive regions. Larger region sizes tend to cause the cache hit-ratio for regions to improve. This improves the write performance, but it also prolongs the recovery time.</p> <p>The default value is 1024 sectors.</p> <p>If DRL sequential logging is configured, the value of <code>voldrl_min_regionsz</code> must be set to at least half the value of <code>vol_maxio</code>.</p>
voliorem_chunk_size	<p>The granularity of memory chunks used by VxVM when allocating or releasing system memory. A larger granularity reduces CPU overhead due to memory allocation by allowing VxVM to retain hold of a larger amount of memory.</p> <p>The default value is 64KB.</p>

**Table 15-1** Kernel tunable parameters for VxVM (*continued*)

Parameter	Description
voliorem_maxpool_sz	<p>The maximum memory requested from the system by VxVM for internal purposes. This tunable has a direct impact on the performance of VxVM as it prevents one I/O operation from using all the memory in the system.</p> <p>VxVM allocates two pools that can grow up to this size, one for RAID-5 and one for mirrored volumes. Additional pools are allocated if instant (Copy On Write) snapshots are present.</p> <p>A write request to a RAID-5 volume that is greater than one fourth of the pool size is broken up and performed in chunks of one tenth of the pool size.</p> <p>A write request to a mirrored volume that is greater than the pool size is broken up and performed in chunks of the pool size.</p> <p>The default value is 5% of memory up to a maximum of 128MB.</p> <p>The value of <code>voliorem_maxpool_sz</code> must be greater than the value of <code>volraid_minpool_size</code>.</p> <p>The value of <code>voliorem_maxpool_sz</code> must be at least 10 times greater than the value of <code>vol_maxio</code>.</p>
voliot_errbuf_dflt	<p>The default size of the buffer maintained for error tracing events. This buffer is allocated at driver load time and is not adjustable for size while VxVM is running.</p> <p>The default value is 16384 bytes (16KB).</p> <p>Increasing this buffer can provide storage for more error events at the expense of system memory. Decreasing the size of the buffer can result in an error not being detected via the tracing device. Applications that depend on error tracing to perform some responsive action are dependent on this buffer.</p>

**Table 15-1** Kernel tunable parameters for VxVM (*continued*)

Parameter	Description
<code>voliot_iobuf_default</code>	<p>The default size for the creation of a tracing buffer in the absence of any other specification of desired kernel buffer size as part of the trace <code>ioctl</code>.</p> <p>The default value is 8192 bytes (8KB).</p> <p>If trace data is often being lost due to this buffer size being too small, then this value can be tuned to a more generous amount.</p>
<code>voliot_iobuf_limit</code>	<p>The upper limit to the size of memory that can be used for storing tracing buffers in the kernel. Tracing buffers are used by the VxVM kernel to store the tracing event records. As trace buffers are requested to be stored in the kernel, the memory for them is drawn from this pool.</p> <p>Increasing this size can allow additional tracing to be performed at the expense of system memory usage. Setting this value to a size greater than can readily be accommodated on the system is inadvisable.</p> <p>The default value is 4194304 bytes (4MB).</p>
<code>voliot_iobuf_max</code>	<p>The maximum buffer size that can be used for a single trace buffer. Requests of a buffer larger than this size are silently truncated to this size. A request for a maximal buffer size from the tracing interface results (subject to limits of usage) in a buffer of this size.</p> <p>The default size for this buffer is 1048576 bytes (1MB).</p> <p>Increasing this buffer can provide for larger traces to be taken without loss for very heavily used volumes.</p> <p>Care should be taken not to increase this value above the value for the <code>voliot_iobuf_limit</code> tunable value.</p>
<code>voliot_max_open</code>	<p>The maximum number of tracing channels that can be open simultaneously. Tracing channels are clone entry points into the tracing device driver. Each <code>vxtrace</code> process running on a system consumes a single trace channel.</p> <p>The default number of channels is 32.</p> <p>The allocation of each channel takes up approximately 20 bytes even when the channel is not in use.</p>

**Table 15-1** Kernel tunable parameters for VxVM (*continued*)

Parameter	Description
volpagemod_max_memsz	<p>The amount of memory, measured in kilobytes, that is allocated for caching FastResync and cache object metadata.</p> <p>The default value is 6144KB (6MB).</p> <p>The valid range for this tunable is from 0 to 50% of physical memory.</p> <p>The memory allocated for this cache is exclusively dedicated to it. It is not available for other processes or applications.</p> <p>Setting the value below 512KB fails if cache objects or volumes that have been prepared for instant snapshot operations are present on the system.</p> <p>If you do not use the FastResync or DRL features that are implemented using a version 20 DCO volume, the value can be set to 0. However, if you subsequently decide to enable these features, you can use the <code>vxtune</code> command to change the value to a more appropriate one:</p> <pre># vxtune volpagemod_max_memsz value</pre> <p>where the new value is specified in kilobytes. Using the <code>vxtune</code> command to adjust the value of <code>volpagemod_max_memsz</code> does not persist across system reboots unless you also adjust the value that is configured in the <code>/kernel/drv/vxio.conf</code> file.</p>
volraid_minpool_size	<p>The initial amount of memory that is requested from the system by VxVM for RAID-5 operations. The maximum size of this memory pool is limited by the value of <code>voliomem_maxpool_sz</code>.</p> <p>The default value is 8192 sectors (4MB).</p>

**Table 15-1** Kernel tunable parameters for VxVM (*continued*)

Parameter	Description
<code>volraid_rsrtransmax</code>	<p>The maximum number of transient reconstruct operations that can be performed in parallel for RAID-5. A transient reconstruct operation is one that occurs on a non-degraded RAID-5 volume that has not been predicted. Limiting the number of these operations that can occur simultaneously removes the possibility of flooding the system with many reconstruct operations, and so reduces the risk of causing memory starvation.</p> <p>The default value is 1.</p> <p>Increasing this size improves the initial performance on the system when a failure first occurs and before a detach of a failing object is performed, but can lead to memory starvation.</p>

## DMP tunable parameters

**Table 15-2** shows the DMP parameters that can be tuned by using the `vxdkmpadm settune` command.

**Table 15-2** DMP parameters that are tunable

Parameter	Description
<code>dmp_cache_open</code>	<p>If this parameter is set to <code>on</code>, the first open of a device that is performed by an array support library (ASL) is cached. This caching enhances the performance of device discovery by minimizing the overhead that is caused by subsequent opens by ASLs. If this parameter is set to <code>off</code>, caching is not performed.</p> <p>The default value is <code>on</code>.</p>
<code>dmp_daemon_count</code>	<p>The number of kernel threads that are available for servicing path error handling, path restoration, and other DMP administrative tasks.</p> <p>The default number of threads is 10.</p>

**Table 15-2** DMP parameters that are tunable (*continued*)

Parameter	Description
dmp_delayq_interval	<p>How long DMP should wait before retrying I/O after an array fails over to a standby path. Some disk arrays are not capable of accepting I/O requests immediately after failover.</p> <p>The default value is 15 seconds.</p>
dmp_enable_restore	<p>If this parameter is set to <code>on</code>, it enables the path restoration thread to be started.</p> <p>See <a href="#">“Configuring DMP path restoration policies”</a> on page 214.</p> <p>If this parameter is set to <code>off</code>, it disables the path restoration thread. If the path restoration thread is currently running, use the <code>vxddmpadm stop restore</code> command to stop the process.</p> <p>See <a href="#">“Stopping the DMP path restoration thread”</a> on page 216.</p>
dmp_failed_io_threshold	<p>The time limit that DMP waits for a failed I/O request to return before the device is marked as INSANE, I/O is avoided on the path, and any remaining failed I/O requests are returned to the application layer without performing any error analysis.</p> <p>The default value is 57600 seconds (16 hours).</p> <p>See <a href="#">“Configuring the response to I/O failures”</a> on page 210.</p> <p>See <a href="#">“Configuring the I/O throttling mechanism”</a> on page 211.</p>
dmp_fast_recovery	<p>Whether DMP should try to obtain SCSI error information directly from the HBA interface. Setting the value to <code>on</code> can potentially provide faster error recovery, provided that the HBA interface supports the error enquiry feature. If this parameter is set to <code>off</code>, the HBA interface is not used.</p> <p>The default setting is <code>on</code>.</p>

**Table 15-2** DMP parameters that are tunable (*continued*)

Parameter	Description
dmp_health_time	<p>DMP detects intermittently failing paths, and prevents I/O requests from being sent on them. The value of <code>dmp_health_time</code> represents the time in seconds for which a path must stay healthy. If a path's state changes back from enabled to disabled within this time period, DMP marks the path as intermittently failing, and does not re-enable the path for I/O until <code>dmp_path_age</code> seconds elapse.</p> <p>The default value is 60 seconds.</p> <p>A value of 0 prevents DMP from detecting intermittently failing paths.</p>
dmp_log_level	<p>The level of detail that is displayed for DMP console messages. The following level values are defined:</p> <ul style="list-style-type: none"> <li>1 – Displays all DMP log messages that existed in releases before 5.0.</li> <li>2 – Displays level 1 messages plus messages that relate to path or disk addition or removal, SCSI errors, IO errors and DMP node migration.</li> <li>3 – Displays level 1 and 2 messages plus messages that relate to path throttling, suspect path, idle path and insane path logic.</li> <li>4 – Displays level 1, 2 and 3 messages plus messages that relate to setting or changing attributes on a path and tunable related changes.</li> </ul> <p>The default value is 1.</p>
dmp_low_impact_probe	<p>Determines if the path probing by restore daemon is optimized or not. Set it to <code>on</code> to enable optimization and <code>off</code> to disable. Path probing is optimized only when restore policy is <code>check_disabled</code> or during <code>check_disabled</code> phase of <code>check_periodic</code> policy.</p> <p>The default value is <code>on</code>.</p>



**Table 15-2** DMP parameters that are tunable (*continued*)

Parameter	Description
dmp_lun_retry_timeout	<p>Retry period for handling transient errors. The value is specified in seconds.</p> <p>When all paths to a disk fail, there may be certain paths that have a temporary failure and are likely to be restored soon. The I/Os may be failed to the application layer even though the failures are transient, unless the I/Os are retried. The <code>dmp_lun_retry_timeout</code> tunable provides a mechanism to retry such transient errors.</p> <p>If the tunable is set to a non-zero value, I/Os to a disk with all failed paths are retried until <code>dmp_lun_retry_timeout</code> interval or until the I/O succeeds on one of the path, whichever happens first.</p> <p>The default value of tunable is 0, which means that the paths are probed only once.</p>
dmp_monitor_fabric	<p>Whether the Event Source daemon (<code>vxesd</code>) uses the Storage Networking Industry Association (SNIA) HBA API. This API allows DDL to improve the performance of failover by collecting information about the SAN topology and by monitoring fabric events.</p> <p>If this parameter is set to <code>on</code>, DDL uses the SNIA HBA API. (Note that the HBA vendor specific HBA-API library should be available to use this feature.)</p> <p>If this parameter is set to <code>off</code>, the SNIA HBA API is not used.</p> <p>The default setting is <code>off</code> for releases before 5.0 that have been patched to support this DDL feature. The default setting is <code>on</code> for 5.0 and later releases.</p>

**Table 15-2** DMP parameters that are tunable (*continued*)

Parameter	Description
dmp_native_multipathing	<p>Determines whether DMP will intercept the I/Os directly on the raw OS paths or not.</p> <p>Set the tunable to <code>on</code> to have DMP do multipathing of I/Os done directly on raw paths, otherwise set it to <code>off</code>.</p> <p>The default value is <code>off</code>.</p>
dmp_path_age	<p>The time for which an intermittently failing path needs to be monitored as healthy before DMP again tries to schedule I/O requests on it.</p> <p>The default value is 300 seconds.</p> <p>A value of 0 prevents DMP from detecting intermittently failing paths.</p>
dmp_pathswitch_blks_shift	<p>The default number of contiguous I/O blocks that are sent along a DMP path to an array before switching to the next available path. The value is expressed as the integer exponent of a power of 2; for example 9 represents 512 blocks.</p> <p>The default value of this parameter is set to 9. In this case, 512 blocks (256k) of contiguous I/O are sent over a DMP path before switching. For intelligent disk arrays with internal data caches, better throughput may be obtained by increasing the value of this tunable. For example, for the HDS 9960 A/A array, the optimal value is between 15 and 17 for an I/O activity pattern that consists mostly of sequential reads or writes.</p> <p>This parameter only affects the behavior of the <code>balanced</code> I/O policy. A value of 0 disables multipathing for the policy unless the <code>vxdmppadm</code> command is used to specify a different partition size for an array.</p> <p>See <a href="#">“Specifying the I/O policy”</a> on page 200.</p>

**Table 15-2** DMP parameters that are tunable (*continued*)

Parameter	Description
<code>dmp_probe_idle_lun</code>	<p>If DMP statistics gathering is enabled, set this tunable to <code>on</code> (default) to have the DMP path restoration thread probe idle LUNs. Set this tunable to <code>off</code> to turn off this feature. (Idle LUNs are VM disks on which no I/O requests are scheduled.) The value of this tunable is only interpreted when DMP statistics gathering is enabled. Turning off statistics gathering also disables idle LUN probing.</p> <p>The default value is <code>on</code>.</p>
<code>dmp_probe_threshold</code>	<p>If the <code>dmp_low_impact_probe</code> is turned <code>on</code>, <code>dmp_probe_threshold</code> determines the number of paths to probe before deciding on changing the state of other paths in the same subpath failover group</p> <p>The default value is 5.</p>
<code>dmp_queue_depth</code>	<p>The maximum number of queued I/O requests on a path during I/O throttling.</p> <p>The default value is 20.</p> <p>A value can also be set for paths to individual arrays by using the <code>vxdmpadm</code> command.</p> <p>See <a href="#">“Configuring the I/O throttling mechanism”</a> on page 211.</p>
<code>dmp_restore_interval</code>	<p>The interval attribute specifies how often the path restoration thread examines the paths. Specify the time in seconds.</p> <p>The default value is 300.</p> <p>The value of this tunable can also be set using the <code>vxdmpadm start restore</code> command.</p> <p>See <a href="#">“Configuring DMP path restoration policies”</a> on page 214.</p>

**Table 15-2** DMP parameters that are tunable (*continued*)

Parameter	Description
dmp_restore_cycles	<p>If the DMP restore policy is <code>check_periodic</code>, the number of cycles after which the <code>check_all</code> policy is called.</p> <p>The default value is 10.</p> <p>The value of this tunable can also be set using the <code>vxddmpadm start restore</code> command.</p> <p>See <a href="#">“Configuring DMP path restoration policies”</a> on page 214.</p>
dmp_restore_policy	<p>The DMP restore policy, which can be set to one of the following values:</p> <ul style="list-style-type: none"> <li>■ <code>check_all</code></li> <li>■ <code>check_alterate</code></li> <li>■ <code>check_disabled</code></li> <li>■ <code>check_periodic</code></li> </ul> <p>The default value is <code>check_disabled</code>.</p> <p>The value of this tunable can also be set using the <code>vxddmpadm start restore</code> command.</p> <p>See <a href="#">“Configuring DMP path restoration policies”</a> on page 214.</p>
dmp_retry_count	<p>If an inquiry succeeds on a path, but there is an I/O error, the number of retries to attempt on the path.</p> <p>The default value is 5.</p> <p>A value can also be set for paths to individual arrays by using the <code>vxddmpadm</code> command.</p> <p>See <a href="#">“Configuring the response to I/O failures”</a> on page 210.</p>

**Table 15-2** DMP parameters that are tunable (*continued*)

Parameter	Description
<code>dmp_scsi_timeout</code>	Determines the timeout value to be set for any SCSI command that is sent via DMP. If the HBA does not receive a response for a SCSI command that it has sent to the device within the timeout period, the SCSI command is returned with a failure error code.  The default value is 30 seconds.
<code>dmp_sfg_threshold</code>	Determines the minimum number of paths that should be failed in a failover group before DMP starts suspecting other paths in the same failover group. The value of 0 disables the failover logic based on subpath failover groups.  The default value is 1.
<code>dmp_stat_interval</code>	The time interval between gathering DMP statistics.  The default and minimum value are 1 second.

## Disabling I/O statistics collection

By default, Veritas Volume Manager collects I/O statistics on all objects in the configuration. This helps you tune different parameters that depend upon the environment and workload.

See [“Tunable parameters for VxVM”](#) on page 556.

See [“DMP tunable parameters”](#) on page 566.

After the tuning is done, you may choose to disable I/O statistics collection because it improves I/O throughput.

### To display whether I/O statistics are enabled

- ◆ Enter the following command:

```
# vxtune vol_stats enable
```

If the system displays 1, I/O statistics collection is enabled. If it displays 0, I/O statistics collection is disabled.

**To disable I/O statistics collection until the next system reboot**

- ◆ Enter the following command:

```
# vxtune vol_stats_enable 0
```

If you are concerned about high I/O throughput, you may also choose to disable DMP I/O statistics collection.

**To disable DMP I/O statistics collection**

- ◆ Enter the following command:

```
# vxdmpadm iostat stop
```

# Using Veritas Volume Manager commands

This appendix includes the following topics:

- [About Veritas Volume Manager commands](#)
- [Online manual pages](#)

## About Veritas Volume Manager commands

Most Veritas Volume Manager (VxVM) commands (excepting daemons, library commands and supporting scripts) are linked to the `/usr/sbin` directory from the `/opt/VRTS/bin` directory. It is recommended that you add the following directories to your `PATH` environment variable:

- If you are using the Bourne or Korn shell (`sh` or `ksh`), use the commands:

```
$ PATH=$PATH:/usr/sbin:/opt/VRTS/bin:/opt/VRTSvxfs/sbin:\
/opt/VRTSdbed/bin:/opt/VRTSdb2ed/bin:/opt/VRTSsybed/bin:\
/opt/VRTSob/bin
$ MANPATH=/usr/share/man:/opt/VRTS/man:$MANPATH
$ export PATH MANPATH
```

- If you are using a C shell (`csh` or `tcsh`), use the commands:

```
% set path = ( $path /usr/sbin /opt/VRTSvxfs/sbin \
/opt/VRTSdbed/bin /opt/VRTSdb2ed/bin /opt/VRTSsybed/bin \
/opt/VRTSob/bin /opt/VRTS/bin )
% setenv MANPATH /usr/share/man:/opt/VRTS/man:$MANPATH
```

---

**Note:** If you have not installed database software, you can omit `/opt/VRTSdbed/bin`, `/opt/VRTSdb2ed/bin` and `/opt/VRTSsybed/bin`. Similarly, `/opt/VRTSvxfes/bin` is only required to access some VxFS commands.

---

VxVM library commands and supporting scripts are located under the `/usr/lib/vxvm` directory hierarchy. You can include these directories in your path if you need to use them on a regular basis.

For detailed information about an individual command, refer to the appropriate manual page in the 1M section.

See “[Online manual pages](#)” on page 597.

Commands and scripts that are provided to support other commands and scripts, and which are not intended for general use, are not located in `/opt/VRTS/bin` and do not have manual pages.

Commonly-used commands are summarized in the following tables:

- [Table A-1](#) lists commands for obtaining information about objects in VxVM.
- [Table A-2](#) lists commands for administering disks.
- [Table A-3](#) lists commands for creating and administering disk groups.
- [Table A-4](#) lists commands for creating and administering subdisks.
- [Table A-5](#) lists commands for creating and administering plexes.
- [Table A-6](#) lists commands for creating volumes.
- [Table A-7](#) lists commands for administering volumes.
- [Table A-8](#) lists commands for monitoring and controlling tasks in VxVM.

**Table A-1**            Obtaining information about objects in VxVM

Command	Description
<code>vxdctl license [init]</code>	List licensed features of VxVM.  The <code>init</code> parameter is required when a license has been added or removed from the host for the new license to take effect.



**Table A-1** Obtaining information about objects in VxVM (*continued*)

Command	Description
<pre>vxdisk [-g <i>diskgroup</i>] list [<i>diskname</i>]</pre>	<p>Lists disks under control of VxVM.</p> <p>See “<a href="#">Displaying disk information</a>” on page 142.</p> <p>Example:</p> <pre># vxdisk -g mydg list</pre>
<pre>vxdbg list [<i>diskgroup</i>]</pre>	<p>Lists information about disk groups.</p> <p>See “<a href="#">Displaying disk group information</a>” on page 224.</p> <p>Example:</p> <pre># vxdbg list mydg</pre>
<pre>vxdbg -s list</pre>	<p>Lists information about shared disk groups.</p> <p>See “<a href="#">Listing shared disk groups</a>” on page 516.</p> <p>Example:</p> <pre># vxdbg -s list</pre>
<pre>vxdisk -o alldgs list</pre>	<p>Lists all diskgroups on the disks. The imparted diskgroups are shown as standard, and additionally all other diskgroups are listed in single quotes.</p>
<pre>vxinfo [-g <i>diskgroup</i>] [<i>volume ...</i>]</pre>	<p>Displays information about the accessibility and usability of volumes.</p> <p>See the <i>Veritas Volume Manager Troubleshooting Guide</i>.</p> <p>Example:</p> <pre># vxinfo -g mydg myvol1 \ myvol2</pre>

**Table A-1** Obtaining information about objects in VxVM (*continued*)

Command	Description
<code>vxprint -hrt [-g <i>diskgroup</i>] [<i>object</i> ...]</code>	<p>Prints single-line information about objects in VxVM.</p> <p>See <a href="#">“Displaying volume information”</a> on page 338.</p> <p>Example:</p> <pre># vxprint -g mydg myvol1 \ myvol2</pre>
<code>vxprint -st [-g <i>diskgroup</i>] [<i>subdisk</i> ...]</code>	<p>Displays information about subdisks.</p> <p>See <a href="#">“Displaying subdisk information”</a> on page 281.</p> <p>Example:</p> <pre># vxprint -st -g mydg</pre>
<code>vxprint -pt [-g <i>diskgroup</i>] [<i>plex</i> ...]</code>	<p>Displays information about plexes.</p> <p>See <a href="#">“Displaying plex information”</a> on page 289.</p> <p>Example:</p> <pre># vxprint -pt -g mydg</pre>

**Table A-2** Administering disks

Command	Description
<code>vxdiskadm</code>	Administers disks in VxVM using a menu-based interface.
<code>vxdiskadd [<i>devicename</i> ...]</code>	<p>Adds a disk specified by device name.</p> <p>See <a href="#">“Using vxdiskadd to put a disk under VxVM control”</a> on page 124.</p> <p>Example:</p> <pre># vxdiskadd c0t1d0</pre>

**Table A-2** Administering disks (*continued*)

Command	Description
<pre>vxedit [-g <i>diskgroup</i>] rename \ olddisk newdisk</pre>	<p>Renames a disk under control of VxVM.</p> <p>See <a href="#">“Renaming a disk”</a> on page 156.</p> <p>Example:</p> <pre># vxedit -g mydg rename \ mydg03 mydg02</pre>
<pre>vxedit [-g <i>diskgroup</i>] set \ reserve=on off <i>diskname</i></pre>	<p>Sets aside/does not set aside a disk from use in a disk group.</p> <p>See <a href="#">“Reserving disks”</a> on page 157.</p> <p>Examples:</p> <pre># vxedit -g mydg set \ reserve=on mydg02 # vxedit -g mydg set \ reserve=off mydg02</pre>
<pre>vxedit [-g <i>diskgroup</i>] set \ nohotuse=on off <i>diskname</i></pre>	<p>Does not/does allow free space on a disk to be used for hot-relocation.</p> <p>See <a href="#">“Excluding a disk from hot-relocation use”</a> on page 478.</p> <p>See <a href="#">“Making a disk available for hot-relocation use”</a> on page 479.</p> <p>Examples:</p> <pre># vxedit -g mydg set \ nohotuse=on mydg03 # vxedit -g mydg set \ nohotuse=off mydg03</pre>

**Table A-2** Administering disks (*continued*)

Command	Description
<pre>vxedit [-g <i>diskgroup</i>] set \  spare=on off <i>diskname</i></pre>	<p>Adds/removes a disk from the pool of hot-relocation spares.</p> <p>See <a href="#">“Marking a disk as a hot-relocation spare”</a> on page 476.</p> <p>See <a href="#">“Removing a disk from use as a hot-relocation spare”</a> on page 478.</p> <p>Examples:</p> <pre># vxedit -g mydg set \    spare=on mydg04  # vxedit -g mydg set \    spare=off mydg04</pre>
<pre>vxdisk offline <i>devicename</i></pre>	<p>Takes a disk offline.</p> <p>See <a href="#">“Taking a disk offline”</a> on page 156.</p> <p>Example:</p> <pre># vxdisk offline c0t1d0</pre>
<pre>vxdg -g <i>diskgroup</i> rmdisk <i>diskname</i></pre>	<p>Removes a disk from its disk group.</p> <p>See <a href="#">“Removing a disk from a disk group”</a> on page 227.</p> <p>Example:</p> <pre># vxdg -g mydg rmdisk mydg02</pre>
<pre>vxdiskunsetup <i>devicename</i></pre>	<p>Removes a disk from control of VxVM.</p> <p>See <a href="#">“Removing a disk from a disk group”</a> on page 227.</p> <p>Example:</p> <pre># vxdiskunsetup c0t3d0</pre>

**Table A-3** Creating and administering disk groups

Command	Description
<pre>vxdg [-s] init <i>diskgroup</i> \ [<i>diskname=</i>]<i>devicename</i></pre>	<p>Creates a disk group using a pre-initialized disk.</p> <p>See <a href="#">“Creating a disk group”</a> on page 226.</p> <p>See <a href="#">“Creating a shared disk group”</a> on page 517.</p> <p>Example:</p> <pre># vxdg init mydg \   mydg01=c0t1d0</pre>
<pre>vxdg -g <i>diskgroup</i> listssbinfo</pre>	<p>Reports conflicting configuration information.</p> <p>See <a href="#">“Handling conflicting configuration copies”</a> on page 250.</p> <p>Example:</p> <pre># vxdg -g mydg listssbinfo</pre>
<pre>vxdg [-n <i>newname</i>] deport <i>diskgroup</i></pre>	<p>Deports a disk group and optionally renames it.</p> <p>See <a href="#">“Deporting a disk group”</a> on page 229.</p> <p>Example:</p> <pre># vxdg -n newdg deport mydg</pre>
<pre>vxdg [-n <i>newname</i>] import <i>diskgroup</i></pre>	<p>Imports a disk group and optionally renames it.</p> <p>See <a href="#">“Importing a disk group”</a> on page 230.</p> <p>Example:</p> <pre># vxdg -n newdg import mydg</pre>

**Table A-3**      Creating and administering disk groups (*continued*)

Command	Description
<code>vxdbg [-n <i>newname</i>] -s import <i>diskgroup</i></code>	<p>Imports a disk group as shared by a cluster, and optionally renames it.</p> <p>See <a href="#">“Importing disk groups as shared”</a> on page 518.</p> <p>Example:</p> <pre># vxdbg -n newsdg -s import \ mysdg</pre>
<code>vxdbg [-o expand] listmove <i>sourcedg</i> \ <i>targetdg</i> <i>object</i> ...</code>	<p>Lists the objects potentially affected by moving a disk group.</p> <p>See <a href="#">“Listing objects potentially affected by a move”</a> on page 261.</p> <p>Example:</p> <pre># vxdbg -o expand listmove \ mydg newdg myvol1</pre>
<code>vxdbg [-o expand] move <i>sourcedg</i> \ <i>targetdg</i> <i>object</i> ...</code>	<p>Moves objects between disk groups.</p> <p>See <a href="#">“Moving objects between disk groups”</a> on page 263.</p> <p>Example:</p> <pre># vxdbg -o expand move mydg \ newdg myvol1</pre>
<code>vxdbg [-o expand] split <i>sourcedg</i> \ <i>targetdg</i> <i>object</i> ...</code>	<p>Splits a disk group and moves the specified objects into the target disk group.</p> <p>See <a href="#">“Splitting disk groups”</a> on page 266.</p> <p>Example:</p> <pre># vxdbg -o expand split mydg \ newdg myvol2 myvol3</pre>

**Table A-3** Creating and administering disk groups (*continued*)

Command	Description
<code>vxvg join sourcedg targetdg</code>	Joins two disk groups. See <a href="#">“Joining disk groups”</a> on page 267. Example: <pre># vxvg join newdg mydg</pre>
<code>vxvg -g diskgroup set \</code> <code>activation=ew ro sr sw off</code>	Sets the activation mode of a shared disk group in a cluster. See <a href="#">“Changing the activation mode on a shared disk group”</a> on page 520. Example: <pre># vxvg -g mysdg set \</pre> <pre>activation=sw</pre>
<code>vxrecover -g diskgroup -sb</code>	Starts all volumes in an imported disk group. See <a href="#">“Moving disk groups between systems”</a> on page 233. Example: <pre># vxrecover -g mydg -sb</pre>
<code>vxvg destroy diskgroup</code>	Destroys a disk group and releases its disks. See <a href="#">“Destroying a disk group”</a> on page 269. Example: <pre># vxvg destroy mydg</pre>

**Table A-4**      Creating and administering subdisks

Command	Description
<pre>vxmake [-g diskgroup] sd subdisk \ diskname,offset,length</pre>	<p>Creates a subdisk.  See <a href="#">Creating subdisks</a>.</p> <p>Example:</p> <pre># vxmake -g mydg sd \ mydg02-01 mydg02,0,8000</pre>
<pre>vxsd [-g diskgroup] assoc plex \ subdisk...</pre>	<p>Associates subdisks with an existing plex.  See <a href="#">“Associating subdisks with plexes”</a> on page 283.</p> <p>Example:</p> <pre># vxsd -g mydg assoc home-1 \ mydg02-01 mydg02-00 \ mydg02-01</pre>
<pre>vxsd [-g diskgroup] assoc plex \ subdisk1:0 ... subdiskM:N-1</pre>	<p>Adds subdisks to the ends of the columns in a striped or RAID-5 volume.  See <a href="#">“Associating subdisks with plexes”</a> on page 283.</p> <p>Example:</p> <pre># vxsd -g mydg assoc \ vol01-01 mydg10-01:0 \ mydg11-01:1 mydg12-01:2</pre>
<pre>vxsd [-g diskgroup] mv oldsubdisk \ newsubdisk ...</pre>	<p>Replaces a subdisk.  See <a href="#">“Moving subdisks”</a> on page 282.</p> <p>Example:</p> <pre># vxsd -g mydg mv mydg01-01 \ mydg02-01</pre>



**Table A-4** Creating and administering subdisks (*continued*)

Command	Description
<pre>vxsd [-g diskgroup] -s size split \ subdisk sd1 sd2</pre>	<p>Splits a subdisk in two.</p> <p>See “<a href="#">Splitting subdisks</a>” on page 282.</p> <p>Example:</p> <pre># vxsd -g mydg -s 1000m \ split mydg03-02 mydg03-02 \ mydg03-03</pre>
<pre>vxsd [-g diskgroup] join \ sd1 sd2 ... subdisk</pre>	<p>Joins two or more subdisks.</p> <p>See “<a href="#">Joining subdisks</a>” on page 283.</p> <p>Example:</p> <pre># vxsd -g mydg join \ mydg03-02 mydg03-03 \ mydg03-02</pre>
<pre>vxassist [-g diskgroup] move \ volume \!olddisk newdisk</pre>	<p>Relocates subdisks in a volume between disks.</p> <p>See “<a href="#">Moving relocated subdisks using vxassist</a>” on page 482.</p> <p>Example:</p> <pre># vxassist -g mydg move \ myvol \!mydg02 mydg05</pre> <p><b>Note:</b> The ! character is a special character in some shells. This example shows how to escape it in a bash shell.</p>
<pre>vxunreloc [-g diskgroup] original_disk</pre>	<p>Relocates subdisks to their original disks.</p> <p>See “<a href="#">Moving relocated subdisks using vxunreloc</a>” on page 483.</p> <p>Example:</p> <pre># vxunreloc -g mydg mydg01</pre>

**Table A-4**      Creating and administering subdisks (*continued*)

Command	Description
<code>vxsd [-g <i>diskgroup</i>] dis <i>subdisk</i></code>	<p>Dissociates a subdisk from a plex.</p> <p>See <a href="#">“Dissociating subdisks from plexes”</a> on page 286.</p> <p>Example:</p> <pre># vxsd -g mydg dis mydg02-01</pre>
<code>vxedit [-g <i>diskgroup</i>] rm <i>subdisk</i></code>	<p>Removes a subdisk.</p> <p>See <a href="#">“Removing subdisks”</a> on page 287.</p> <p>Example:</p> <pre># vxedit -g mydg rm mydg02-01</pre>
<code>vxsd [-g <i>diskgroup</i>] -o rm dis <i>subdisk</i></code>	<p>Dissociates and removes a subdisk from a plex.</p> <p>See <a href="#">“Dissociating subdisks from plexes”</a> on page 286.</p> <p>Example:</p> <pre># vxsd -g mydg -o rm dis \ mydg02-01</pre>

**Table A-5**      Creating and administering plexes

Command	Description
<code>vxmake [-g <i>diskgroup</i>] plex <i>plex</i> \ sd=<i>subdisk1</i>[,<i>subdisk2</i>,...]</code>	<p>Creates a concatenated plex.</p> <p>See <a href="#">“Creating plexes”</a> on page 289.</p> <p>Example:</p> <pre># vxmake -g mydg plex \ vol01-02 \ sd=mydg02-01,mydg02-02</pre>

**Table A-5** Creating and administering plexes (*continued*)

Command	Description
<pre>vxmake [-g diskgroup] plex <i>plex</i> \ layout=stripe raid5 stwidth=<i>W</i> \ ncolumn=<i>N</i> \ sd=<i>subdisk1</i>[,<i>subdisk2</i>,...]</pre>	<p>Creates a striped or RAID-5 plex.</p> <p>See <a href="#">“Creating a striped plex”</a> on page 289.</p> <p>Example:</p> <pre># vxmake -g mydg plex pl-01 \   layout=stripe stwidth=32 \   ncolumn=2 \   sd=mydg01-01,mydg02-01</pre>
<pre>vxplex [-g diskgroup] att <i>volume plex</i></pre>	<p>Attaches a plex to an existing volume.</p> <p>See <a href="#">“Attaching and associating plexes”</a> on page 294.</p> <p>See <a href="#">“Reattaching plexes”</a> on page 296.</p> <p>Example:</p> <pre># vxplex -g mydg att vol01 \   vol01-02</pre>
<pre>vxplex [-g diskgroup] det <i>plex</i></pre>	<p>Detaches a plex.</p> <p>See <a href="#">“Detaching plexes”</a> on page 296.</p> <p>Example:</p> <pre># vxplex -g mydg det vol01-02</pre>
<pre>vxmend [-g diskgroup] off <i>plex</i></pre>	<p>Takes a plex offline for maintenance.</p> <p>See <a href="#">“Taking plexes offline”</a> on page 295.</p> <p>Example:</p> <pre># vxmend -g mydg off vol02-02</pre>
<pre>vxmend [-g diskgroup] on <i>plex</i></pre>	<p>Re-enables a plex for use.</p> <p>See <a href="#">“Reattaching plexes”</a> on page 296.</p> <p>Example:</p> <pre># vxmend -g mydg on vol02-02</pre>

**Table A-5**      Creating and administering plexes (*continued*)

Command	Description
<pre>vxplex [-g <i>diskgroup</i>] mv <i>oldplex</i> \ <i>newplex</i></pre>	<p>Replaces a plex.</p> <p>See <a href="#">“Moving plexes”</a> on page 298.</p> <p>Example:</p> <pre># vxplex -g mydg mv \   vol102-02 vol102-03</pre>
<pre>vxplex [-g <i>diskgroup</i>] cp <i>volume</i> \ <i>newplex</i></pre>	<p>Copies a volume onto a plex.</p> <p>See <a href="#">“Copying volumes to plexes”</a> on page 299.</p> <p>Example:</p> <pre># vxplex -g mydg cp vol102 \   vol103-01</pre>
<pre>vxmend [-g <i>diskgroup</i>] fix clean <i>plex</i></pre>	<p>Sets the state of a plex in an unstartable volume to CLEAN.</p> <p>See <a href="#">“Reattaching plexes”</a> on page 296.</p> <p>Example:</p> <pre># vxmend -g mydg fix clean \   vol102-02</pre>
<pre>vxplex [-g <i>diskgroup</i>] -o rm dis <i>plex</i></pre>	<p>Dissociates and removes a plex from a volume.</p> <p>See <a href="#">“Dissociating and removing plexes”</a> on page 299.</p> <p>Example:</p> <pre># vxplex -g mydg -o rm dis \   vol103-01</pre>

**Table A-6** Creating volumes

Command	Description
<pre>vxassist [-g <i>diskgroup</i>] maxsize \ layout=<i>layout</i> [<i>attributes</i>]</pre>	<p>Displays the maximum size of volume that can be created.</p> <p>See <a href="#">“Discovering the maximum size of a volume”</a> on page 311.</p> <p>Example:</p> <pre># vxassist -g mydg maxsize \ layout=raid5 nlog=2</pre>
<pre>vxassist -b [-g <i>diskgroup</i>] make \ volume length [<i>layout=layout</i>] \ [<i>attributes</i>]</pre>	<p>Creates a volume.</p> <p>See <a href="#">“Creating a volume on any disk”</a> on page 312.</p> <p>See <a href="#">“Creating a volume on specific disks”</a> on page 313.</p> <p>Example:</p> <pre># vxassist -b -g mydg make \ myvol 20g layout=concat \ mydg01 mydg02</pre>
<pre>vxassist -b [-g <i>diskgroup</i>] make \ volume length layout=mirror \ [<i>nmirror=N</i>] [<i>attributes</i>]</pre>	<p>Creates a mirrored volume.</p> <p>See <a href="#">“Creating a mirrored volume”</a> on page 319.</p> <p>Example:</p> <pre># vxassist -b -g mydg make \ mymvol 20g layout=mirror \ nmirror=2</pre>
<pre>vxassist -b [-g <i>diskgroup</i>] make \ volume length layout=<i>layout</i> \ exclusive=on [<i>attributes</i>]</pre>	<p>Creates a volume that may be opened exclusively by a single node in a cluster.</p> <p>See <a href="#">“Creating volumes with exclusive open access by a node”</a> on page 521.</p> <p>Example:</p> <pre># vxassist -b -g mysdg make \ mysmvol 20g layout=mirror \ exclusive=on</pre>

**Table A-6**      Creating volumes (*continued*)

Command	Description
<pre>vxassist -b [-g <i>diskgroup</i>] make \ <i>volume length</i> layout={stripe raid5} \ [<i>stripeunit=W</i>] [<i>ncol=N</i>] \ [<i>attributes</i>]</pre>	<p>Creates a striped or RAID-5 volume.</p> <p>See <a href="#">“Creating a striped volume”</a> on page 325.</p> <p>See <a href="#">“Creating a RAID-5 volume”</a> on page 329.</p> <p>Example:</p> <pre># vxassist -b -g mydg make \ mysvol 20g layout=stripe \ stripeunit=32 ncol=4</pre>
<pre>vxassist -b [-g <i>diskgroup</i>] make \ <i>volume length</i> layout=mirror \ mirror=ctlr [<i>attributes</i>]</pre>	<p>Creates a volume with mirrored data plexes on separate controllers.</p> <p>See <a href="#">“Mirroring across targets, controllers or enclosures”</a> on page 327.</p> <p>Example:</p> <pre># vxassist -b -g mydg make \ mymcvol 20g layout=mirror \ mirror=ctlr</pre>
<pre>vxmake -b [-g <i>diskgroup</i>] \ -U<i>usage_type</i> vol <i>volume</i> \ [<i>len=length</i>] plex=<i>plex</i>,...</pre>	<p>Creates a volume from existing plexes.</p> <p>See <a href="#">“Creating a volume using vxmake”</a> on page 331.</p> <p>Example:</p> <pre># vxmake -g mydg -Uraid5 \ vol r5vol \ plex=raidplex,raidlog1,\ raidlog2</pre>
<pre>vxvol [-g <i>diskgroup</i>] start <i>volume</i></pre>	<p>Initializes and starts a volume for use.</p> <p>See <a href="#">“Initializing and starting a volume”</a> on page 334.</p> <p>See <a href="#">“Starting a volume”</a> on page 350.</p> <p>Example:</p> <pre># vxvol -g mydg start r5vol</pre>

**Table A-6** Creating volumes (*continued*)

Command	Description
<code>vxvol [-g <i>diskgroup</i>] init zero \ <i>volume</i></code>	<p>Initializes and zeros out a volume for use.</p> <p>See <a href="#">“Initializing and starting a volume”</a> on page 334.</p> <p>Example:</p> <pre># vxvol -g mydg init zero \ myvol</pre>

**Table A-7** Administering volumes

Command	Description
<code>vxassist [-g <i>diskgroup</i>] mirror \ <i>volume</i> [<i>attributes</i>]</code>	<p>Adds a mirror to a volume.</p> <p>See <a href="#">“Adding a mirror to a volume”</a> on page 355.</p> <p>Example:</p> <pre># vxassist -g mydg mirror \ myvol mydg10</pre>
<code>vxassist [-g <i>diskgroup</i>] remove \ mirror <i>volume</i> [<i>attributes</i>]</code>	<p>Removes a mirror from a volume.</p> <p>See <a href="#">“Removing a mirror”</a> on page 359.</p> <p>Example:</p> <pre># vxassist -g mydg remove \ mirror myvol \!mydg11</pre> <p><b>Note:</b> The ! character is a special character in some shells. This example shows how to escape it in a bash shell.</p>

**Table A-7** Administering volumes (*continued*)

Command	Description
<code>vxassist [-g <i>diskgroup</i>] \ {growto growby} <i>volume length</i></code>	<p>Grows a volume to a specified size or by a specified amount.</p> <p>See <a href="#">“Resizing volumes with vxassist”</a> on page 353.</p> <p>Example:</p> <pre># vxassist -g mydg growby \ myvol 10g</pre>
<code>vxassist [-g <i>diskgroup</i>] \ {shrinkto shrinkby} <i>volume length</i></code>	<p>Shrinks a volume to a specified size or by a specified amount.</p> <p>See <a href="#">“Resizing volumes with vxassist”</a> on page 353.</p> <p>Example:</p> <pre># vxassist -g mydg shrinkto \ myvol 20g</pre>
<code>vxresize -b -F vxfs [-g <i>diskgroup</i>] \ <i>volume length diskname ...</i></code>	<p>Resizes a volume and the underlying Veritas File System.</p> <p>See <a href="#">“Resizing volumes with vxresize”</a> on page 352.</p> <p>Example:</p> <pre># vxresize -b -F vxfs \ -g mydg myvol 20g mydg10 \ mydg11</pre>
<code>vxsnap [-g <i>diskgroup</i>] prepare <i>volume</i> \ {drl=on sequential off}</code>	<p>Prepares a volume for instant snapshots and for DRL logging.</p> <p>See <a href="#">“Preparing a volume for DRL and instant snapshots”</a> on page 360.</p> <p>Example:</p> <pre># vxsnap -g mydg prepare \ myvol drl=on</pre>



**Table A-7** Administering volumes (*continued*)

Command	Description
<pre>vxsnap [-g diskgroup] make \ source=volume\ /newvol=snapvol\ [/nmirror=number]</pre>	<p>Takes a full-sized instant snapshot of a volume by breaking off plexes of the original volume.</p> <p>See <a href="#">“Creating instant snapshots”</a> on page 400.</p> <p>Example:</p> <pre># vxsnap -g mydg make \   source=myvol/\   newvol=mysnpvol/\   nmirror=2</pre>
<pre>vxsnap [-g diskgroup] make \ source=volume/snapvol=snapvol</pre>	<p>Takes a full-sized instant snapshot of a volume using a prepared empty volume. See <a href="#">Creating a volume for use as a full-sized instant or linked break-off snapshot</a>.</p> <p>See <a href="#">“Creating instant snapshots”</a> on page 400.</p> <p>Example:</p> <pre># vxsnap -g mydg make \   source=myvol/snapvol=snpvol</pre>
<pre>vxmake [-g diskgroup] cache \ cache_object cachevolname=volume \ [regionsize=size]</pre>	<p>Creates a cache object for use by space-optimized instant snapshots.</p> <p>See <a href="#">“Creating a shared cache object”</a> on page 403.</p> <p>A cache volume must have already been created. After creating the cache object, enable the cache object with the <code>vxcache start</code> command.</p> <p>For example:</p> <pre># vxassist -g mydg make \   cvol 1g layout=mirror \   init=active mydg16 mydg17 # vxmake -g mydg cache cobj \   cachevolname=cvol # vxcache -g mydg start cobj</pre>

**Table A-7** Administering volumes (*continued*)

Command	Description
<pre>vxsnap [-g <i>diskgroup</i>] make \ source=<i>volume</i>/newvol=<i>snapvol</i>\ /cache=<i>cache_object</i></pre>	<p>Takes a space-optimized instant snapshot of a volume.</p> <p>See <a href="#">“Creating instant snapshots”</a> on page 400.</p> <p>Example:</p> <pre># vxsnap -g mydg make \ source=myvol/\ newvol=mysosvol/\ cache=cobj</pre>
<pre>vxsnap [-g <i>diskgroup</i>] refresh <i>snapshot</i></pre>	<p>Refreshes a snapshot from its original volume.</p> <p>See <a href="#">“Refreshing an instant snapshot”</a> on page 420.</p> <p>Example:</p> <pre># vxsnap -g mydg refresh \ mysnpvol</pre>
<pre>vxsnap [-g <i>diskgroup</i>] dis <i>snapshot</i></pre>	<p>Turns a snapshot into an independent volume.</p> <p>See <a href="#">“Dissociating an instant snapshot”</a> on page 423.</p> <p>Example:</p> <pre># vxsnap -g mydg dis mysnpvol</pre>
<pre>vxsnap [-g <i>diskgroup</i>] unprepare \ <i>volume</i></pre>	<p>Removes support for instant snapshots and DRL logging from a volume.</p> <p>See <a href="#">“Removing support for DRL and instant snapshots from a volume”</a> on page 365.</p> <p>Example:</p> <pre># vxsnap -g mydg unprepare \ myvol</pre>

**Table A-7** Administering volumes (*continued*)

Command	Description
<pre>vxassist [-g <i>diskgroup</i>] relayout \ volume [layout=<i>layout</i>] \ [<i>relayout_options</i>]</pre>	<p>Performs online relayout of a volume.</p> <p>See <a href="#">“Performing online relayout”</a> on page 376.</p> <p>Example:</p> <pre># vxassist -g mydg relayout \ vol2 layout=stripe</pre>
<pre>vxassist [-g <i>diskgroup</i>] relayout \ volume layout=raid5 \ stripeunit=<i>W</i> \ ncol=<i>N</i></pre>	<p>Relays out a volume as a RAID-5 volume with stripe width <i>W</i> and <i>N</i> columns.</p> <p>See <a href="#">“Performing online relayout”</a> on page 376.</p> <p>Example:</p> <pre># vxassist -g mydg relayout \ vol3 layout=raid5 \ stripeunit=16 ncol=4</pre>
<pre>vxrelayout [-g <i>diskgroup</i>] -o <i>bg</i> \ reverse <i>volume</i></pre>	<p>Reverses the direction of a paused volume relayout.</p> <p>See <a href="#">“Volume sets”</a> on page 73.</p> <p>Example:</p> <pre># vxrelayout -g mydg -o <i>bg</i> \ reverse <i>vol3</i></pre>
<pre>vxassist [-g <i>diskgroup</i>] convert \ volume [layout=<i>layout</i>] \ [<i>convert_options</i>]</pre>	<p>Converts between a layered volume and a non-layered volume layout.</p> <p>See <a href="#">“Converting between layered and non-layered volumes”</a> on page 383.</p> <p>Example:</p> <pre># vxassist -g mydg convert \ vol3 layout=stripe-mirror</pre>

**Table A-7** Administering volumes (*continued*)

Command	Description
<code>vxassist [-g <i>diskgroup</i>] remove \ volume <i>volume</i></code>	Removes a volume. See <a href="#">“Removing a volume”</a> on page 372. Example:  # vxassist -g mydg remove \ myvol

**Table A-8** Monitoring and controlling tasks

Command	Description
<code>command [-g <i>diskgroup</i>] -t <i>tasktag</i> \ [<i>options</i>] [<i>arguments</i>]</code>	Specifies a task tag to a VxVM command. See <a href="#">“Specifying task tags”</a> on page 342. Example:  # vxrecover -g mydg \ -t mytask -b mydg05
<code>vxtask [-h] [-g <i>diskgroup</i>] list</code>	Lists tasks running on a system. See <a href="#">“Using the vxtask command”</a> on page 344. Example:  # vxtask -h -g mydg list
<code>vxtask monitor <i>task</i></code>	Monitors the progress of a task. See <a href="#">“Using the vxtask command”</a> on page 344. Example:  # vxtask monitor mytask

**Table A-8** Monitoring and controlling tasks (*continued*)

Command	Description
<code>vxtask pause task</code>	Suspends operation of a task. See <a href="#">“Using the vxtask command”</a> on page 344. Example: <pre># vxtask pause mytask</pre>
<code>vxtask -p [-g diskgroup] list</code>	Lists all paused tasks. See <a href="#">“Using the vxtask command”</a> on page 344. Example: <pre># vxtask -p -g mydg list</pre>
<code>vxtask resume task</code>	Resumes a paused task. See <a href="#">“Using the vxtask command”</a> on page 344. Example: <pre># vxtask resume mytask</pre>
<code>vxtask abort task</code>	Cancels a task and attempts to reverse its effects. See <a href="#">“Using the vxtask command”</a> on page 344. Example: <pre># vxtask abort mytask</pre>

## Online manual pages

Manual pages are organized into the following sections:

- 1M Administrative commands.
- 4 File formats.

7 Device driver interfaces.

## Section 1M — administrative commands

[Table A-9](#) lists the manual pages in section 1M for commands that are used to administer Veritas Volume Manager.

**Table A-9** Section 1M manual pages

Name	Description
<code>vxapslice</code>	Manage an area of disk for use by an Alternate Pathing database.
<code>vxassist</code>	Create, layout, convert, mirror, backup, grow, shrink, delete, and move volumes.
<code>vxbootsetup</code>	Set up system boot information on a Veritas Volume Manager disk.
<code>vxcache</code>	Administer the cache object for space-optimized snapshots.
<code>vxcached</code>	Resize cache volumes when required.
<code>vxcdsconvert</code>	Make disks and disk groups portable between systems.
<code>vxclustadm</code>	Start, stop, and reconfigure a cluster.
<code>vxcmdlog</code>	Administer command logging.
<code>vxconfigbackup</code>	Back up disk group configuration.
<code>vxconfigbackupd</code>	Disk group configuration backup daemon.
<code>vxconfigd</code>	Veritas Volume Manager configuration daemon
<code>vxconfigrestore</code>	Restore disk group configuration.
<code>vxdarestore</code>	Restore simple or nopriv disk access records.
<code>vxdc0</code>	Perform operations on version 0 DCO objects and DCO volumes.
<code>vxctl</code>	Control the volume configuration daemon.

**Table A-9** Section 1M manual pages (*continued*)

Name	Description
vxddladm	Device Discovery Layer subsystem administration.
vxdefault	Manage the defaults set in <code>/etc/default/vxsf</code> that configure settings such as smartmove thin reclamation.
vxdg	Manage Veritas Volume Manager disk groups.
vxdisk	Define and manage Veritas Volume Manager disks.
vxdiskadd	Add one or more disks for use with Veritas Volume Manager.
vxdiskadm	Menu-driven Veritas Volume Manager disk administration.
vxdiskconfig	Configure disk devices and bring them under VxVM control.
vxdisksetup	Configure a disk for use with Veritas Volume Manager.
vxdiskunsetup	Deconfigure a disk from use with Veritas Volume Manager.
vxmpadm	DMP subsystem administration.
vxedit	Create, remove, and modify Veritas Volume Manager records.
vxencap	Encapsulate partitions on a new disk.
vxevac	Evacuate all volumes from a disk.
vxinfo	Print accessibility and usability of volumes.
vxinstall	Menu-driven Veritas Volume Manager initial configuration.
vxintro	Introduction to the Veritas Volume Manager utilities.

**Table A-9** Section 1M manual pages (*continued*)

Name	Description
<code>vxiod</code>	Start, stop, and report on Veritas Volume Manager kernel I/O threads.
<code>vxlufinish</code>	Finish a live upgrade of Veritas Volume Manager.
<code>vxlustart</code>	Start a live upgrade of Veritas Volume Manager.
<code>vxmake</code>	Create Veritas Volume Manager configuration records.
<code>vxmemstat</code>	Display memory statistics for Veritas Volume Manager.
<code>vxmend</code>	Mend simple problems in configuration records.
<code>vxmirror</code>	Mirror volumes on a disk or control default mirroring.
<code>vxnotify</code>	Display Veritas Volume Manager configuration events.
<code>vxplex</code>	Perform Veritas Volume Manager operations on plexes.
<code>vxprint</code>	Display records from the Veritas Volume Manager configuration.
<code>vxr5check</code>	Verify RAID-5 volume parity.
<code>vxreattach</code>	Reattach disk drives that have become accessible again.
<code>vxrecover</code>	Perform volume recovery operations.
<code>vxrelayout</code>	Convert online storage from one layout to another.
<code>vxrelocd</code>	Monitor Veritas Volume Manager for failure events and relocate failed subdisks.
<code>vxresize</code>	Change the length of a volume containing a file system.
<code>vxrootadm</code>	Grow or take snapshots of the boot disk.



**Table A-9** Section 1M manual pages (*continued*)

Name	Description
<code>vxscsiinq</code>	Display SCSI inquiry data.
<code>vxsd</code>	Perform Veritas Volume Manager operations on subdisks.
<code>vxsnap</code>	Enable DRL on a volume, and create and administer instant snapshots.
<code>vxsparecheck</code>	Monitor for disk failure, and replace failed disks.
<code>vxstat</code>	Veritas Volume Manager statistics management utility.
<code>vxtask</code>	List and administer Veritas Volume Manager tasks.
<code>vxtrace</code>	Trace operations on volumes.
<code>vxtranslog</code>	Administer transaction logging.
<code>vxtune</code>	Adjust Veritas Volume Replicator and Veritas Volume Manager tunables.
<code>vxunreloc</code>	Move a hot-relocated subdisk back to its original disk.
<code>vxunroot</code>	Remove Veritas Volume Manager hooks from encapsulated root volumes.
<code>vxvol</code>	Perform Veritas Volume Manager operations on volumes.
<code>vxvset</code>	Create and administer volume sets.

## Section 4 — file formats

[Table A-10](#) lists the manual pages in section 4 that describe the format of files that are used by Veritas Volume Manager.

**Table A-10** Section 4 manual pages

Name	Description
<code>vol_pattern</code>	Disk group search specifications.

**Table A-10** Section 4 manual pages (*continued*)

Name	Description
vxmake	vxmake description file.

## Section 7 — device driver interfaces

[Table A-11](#) lists the manual pages in section 7 that describe the interfaces to Veritas Volume Manager devices.

**Table A-11** Section 7 manual pages

Name	Description
vxconfig	Configuration device.
vxdmp	Dynamic multipathing device.
vxinfo	General information device.
vxio	Virtual disk device.
vxiod	I/O daemon process control device.
vxtrace	I/O tracing device.

# Configuring Veritas Volume Manager

This appendix includes the following topics:

- [Setup tasks after installation](#)
- [Unsupported disk arrays](#)
- [Foreign devices](#)
- [Initialization of disks and creation of disk groups](#)
- [Guidelines for configuring storage](#)
- [VxVM's view of multipathed devices](#)
- [Cluster support](#)

## Setup tasks after installation

A number of setup tasks can be performed after installing the Veritas Volume Manager (VxVM) software.

The following tasks are to perform initial setup:

- Create disk groups by placing disks under Veritas Volume Manager control.
- Create volumes in the disk groups.
- Configure file systems on the volumes.

The following setup tasks are optional:

- Encapsulate the `root` disk, and mirror it to create an alternate boot disk.
- Designate hot-relocation spare disks in each disk group.

- Add mirrors to volumes.
- Configure DRL and FastResync on volumes.

The following tasks are to perform ongoing maintenance:

- Resize volumes and file systems.
- Add more disks, create new disk groups, and create new volumes.
- Create and maintain snapshots.

## Unsupported disk arrays

After installation, add any disk arrays that are unsupported by Symantec to the DISKS (JBOD) category.

See [“How to administer the Device Discovery Layer”](#) on page 92.

## Foreign devices

The device discovery feature of VxVM can discover some devices that are controlled by third-party drivers, such as for EMC PowerPath. For these devices it may be preferable to use the multipathing capability that is provided by the third-party drivers rather than using the Dynamic Multipathing (DMP) feature. Provided that a suitable array support library is available, DMP can co-exist with such drivers. Other foreign devices, for which a compatible ASL does not exist, can be made available to Veritas Volume Manager as simple disks by using the `vxdldadm addforeign` command. This also has the effect of bypassing DMP.

See [“How to administer the Device Discovery Layer”](#) on page 92.

## Initialization of disks and creation of disk groups

To place disks in disk groups, use the `vxdiskadm` program after completing the installation.

See [“Adding a disk to VxVM”](#) on page 115.

## Guidelines for configuring storage

A disk failure can cause loss of data on the failed disk and loss of access to your system. Loss of access is due to the failure of a key disk used for system operations. Veritas Volume Manager can protect your system from these problems.

To maintain system availability, data important to running and booting your system must be mirrored. The data must be preserved so it can be used in case of failure.

The following are suggestions for protecting your system and data:

- Perform regular backups to protect your data. Backups are necessary if all copies of a volume are lost or corrupted. Power surges can damage several (or all) disks on your system. Also, typing a command in error can remove critical files or damage a file system directly. Performing regular backups ensures that lost or corrupted data is available to be retrieved.
- Place the disk containing the `root` file system (the root or boot disk) under Veritas Volume Manager control through encapsulation. Encapsulation converts the `root` and `swap` devices to volumes (`rootvol` and `swapvol`). Mirror the root disk so that an alternate root disk exists for booting purposes. By mirroring disks critical to booting, you ensure that no single disk failure leaves your system unbootable and unusable.  
See “[Rootability](#)” on page 131.
- Use mirroring to protect data against loss from a disk failure.  
See “[Mirroring guidelines](#)” on page 605.
- Use the DRL feature to speed up recovery of mirrored volumes after a system crash.  
See “[Dirty region logging guidelines](#)” on page 606.
- Use striping to improve the I/O performance of volumes.  
See “[Striping guidelines](#)” on page 607.
- Make sure enough disks are available for a combined striped and mirrored configuration. At least two disks are required for the striped plex, and one or more additional disks are needed for the mirror.
- When combining striping and mirroring, never place subdisks from one plex on the same physical disk as subdisks from the other plex.
- Use logging to prevent corruption of recovery data in RAID-5 volumes. Make sure that each RAID-5 volume has at least one log plex.  
See “[RAID-5 guidelines](#)” on page 608.
- Leave the Veritas Volume Manager hot-relocation feature enabled.  
See “[Hot-relocation guidelines](#)” on page 608.

## Mirroring guidelines

Refer to the following guidelines when using mirroring.

- Do not place subdisks from different plexes of a mirrored volume on the same physical disk. This action compromises the availability benefits of mirroring and degrades performance. Using the `vxassist` or `vxdiskadm` commands precludes this from happening.
- To provide optimum performance improvements through the use of mirroring, at least 70 percent of physical I/O operations should be read operations. A higher percentage of read operations results in even better performance. Mirroring may not provide a performance increase or may even result in a performance decrease in a write-intensive workload environment.
- The operating system implements a file system cache. Read requests can frequently be satisfied from the cache. This can cause the read/write ratio for physical I/O operations through the file system to be biased toward writing (when compared to the read/write ratio at the application level).
- Where possible, use disks attached to different controllers when mirroring or striping. Most disk controllers support overlapped seeks. This allows seeks to begin on two disks at once. Do not configure two plexes of the same volume on disks that are attached to a controller that does not support overlapped seeks. This is important for older controllers or SCSI disks that do not cache on the drive. It is less important for modern SCSI disks and controllers. Mirroring across controllers allows the system to survive a failure of one of the controllers. Another controller can continue to provide data from a mirror.
- A plex exhibits superior performance when striped or concatenated across multiple disks, or when located on a much faster device. Set the read policy to prefer the faster plex. By default, a volume with one striped plex is configured to prefer reading from the striped plex.

See “[Mirroring \(RAID-1\)](#)” on page 43.

## Dirty region logging guidelines

Dirty region logging (DRL) can speed up recovery of mirrored volumes following a system crash. When DRL is enabled, Veritas Volume Manager keeps track of the regions within a volume that have changed as a result of writes to a plex.

---

**Warning:** Using Dirty Region Logging can adversely impact system performance in a write-intensive environment.

---

See “[Dirty region logging](#)” on page 59.

## Striping guidelines

Refer to the following guidelines when using striping.

- Do not place more than one column of a striped plex on the same physical disk.
- Calculate stripe-unit sizes carefully. In general, a moderate stripe-unit size (for example, 64 kilobytes, which is also the default used by `vxassist`) is recommended.
- If it is not feasible to set the stripe-unit size to the track size, and you do not know the application I/O pattern, use the default stripe-unit size.
- Many modern disk drives have variable geometry. This means that the track size differs between cylinders, so that outer disk tracks have more sectors than inner tracks. It is therefore not always appropriate to use the track size as the stripe-unit size. For these drives, use a moderate stripe-unit size (such as 64 kilobytes), unless you know the I/O pattern of the application.
- Volumes with small stripe-unit sizes can exhibit poor sequential I/O latency if the disks do not have synchronized spindles. Generally, striping over disks without synchronized spindles yields better performance when used with larger stripe-unit sizes and multi-threaded, or largely asynchronous, random I/O streams.
- Typically, the greater the number of physical disks in the stripe, the greater the improvement in I/O performance; however, this reduces the effective mean time between failures of the volume. If this is an issue, combine striping with mirroring to combine high-performance with improved reliability.
- If only one plex of a mirrored volume is striped, set the policy of the volume to `prefer` for the striped plex. (The default read policy, `select`, does this automatically.)
- If more than one plex of a mirrored volume is striped, configure the same stripe-unit size for each striped plex.
- Where possible, distribute the subdisks of a striped volume across drives connected to different controllers and buses.
- Avoid the use of controllers that do not support overlapped seeks. (Such controllers are rare.)

The `vxassist` command automatically applies and enforces many of these rules when it allocates space for striped plexes in a volume.

See [“Striping \(RAID-0\)”](#) on page 40.

## RAID-5 guidelines

Refer to the following guidelines when using RAID-5.

In general, the guidelines for mirroring and striping together also apply to RAID-5. The following guidelines should also be observed with RAID-5:

- Only one RAID-5 plex can exist per RAID-5 volume (but there can be multiple log plexes).
- The RAID-5 plex must be derived from at least three subdisks on three or more physical disks. If any log plexes exist, they must belong to disks other than those used for the RAID-5 plex.
- RAID-5 logs can be mirrored and striped.
- If the volume length is not explicitly specified, it is set to the length of any RAID-5 plex associated with the volume; otherwise, it is set to zero. If you specify the volume length, it must be a multiple of the stripe-unit size of the associated RAID-5 plex, if any.
- If the log length is not explicitly specified, it is set to the length of the smallest RAID-5 log plex that is associated, if any. If no RAID-5 log plexes are associated, it is set to zero.
- Sparse RAID-5 log plexes are not valid.
- RAID-5 volumes are not supported for sharing in a cluster.

See “[RAID-5 \(striping with parity\)](#)” on page 46.

## Hot-relocation guidelines

Hot-relocation automatically restores redundancy and access to mirrored and RAID-5 volumes when a disk fails. This is done by relocating the affected subdisks to disks designated as spares and/or free space in the same disk group.

The hot-relocation feature is enabled by default. The associated daemon, `vxrelocd`, is automatically started during system startup.

Refer to the following guidelines when using hot-relocation.

- The hot-relocation feature is enabled by default. Although it is possible to disable hot-relocation, it is advisable to leave it enabled. It will notify you of the nature of the failure, attempt to relocate any affected subdisks that are redundant, and initiate recovery procedures.
- Although hot-relocation does not require you to designate disks as spares, designate at least one disk as a spare within each disk group. This gives you some control over which disks are used for relocation. If no spares exist, Veritas Volume Manager uses any available free space within the disk group. When



free space is used for relocation purposes, it is possible to have performance degradation after the relocation.

- After hot-relocation occurs, designate one or more additional disks as spares to augment the spare space. Some of the original spare space may be occupied by relocated subdisks.
- If a given disk group spans multiple controllers and has more than one spare disk, set up the spare disks on different controllers (in case one of the controllers fails).
- For a mirrored volume, configure the disk group so that there is at least one disk that does not already contain a mirror of the volume. This disk should either be a spare disk with some available space or a regular disk with some free space and the disk is not excluded from hot-relocation use.
- For a mirrored and striped volume, configure the disk group so that at least one disk does not already contain one of the mirrors of the volume or another subdisk in the striped plex. This disk should either be a spare disk with some available space or a regular disk with some free space and the disk is not excluded from hot-relocation use.
- For a RAID-5 volume, configure the disk group so that at least one disk does not already contain the RAID-5 plex (or one of its log plexes) of the volume. This disk should either be a spare disk with some available space or a regular disk with some free space and the disk is not excluded from hot-relocation use.
- If a mirrored volume has a DRL log subdisk as part of its data plex, you cannot relocate the data plex. Instead, place log subdisks in log plexes that contain no data.
- Hot-relocation does not guarantee to preserve the original performance characteristics or data layout. Examine the locations of newly-relocated subdisks to determine whether they should be relocated to more suitable disks to regain the original performance benefits.
- Although it is possible to build Veritas Volume Manager objects on spare disks, it is recommended that you use spare disks for hot-relocation only.

See [“How hot-relocation works”](#) on page 468.

## Accessing volume devices

As soon as a volume has been created and initialized, it is available for use as a virtual disk partition by the operating system for the creation of a file system, or by application programs such as relational databases and other data management software.

Creating a volume in a disk group sets up block and character (raw) device files that can be used to access the volume:

<code>/dev/vx/dsk/dg/vol</code>	block device file for volume <i>vol</i> in disk group <i>dg</i>
<code>/dev/vx/rdisk/dg/vol</code>	character device file for volume <i>vol</i> in disk group <i>dg</i>

The pathnames include a directory named for the disk group. Use the appropriate device node to create, mount and repair file systems, and to lay out databases that require raw partitions.

## VxVM's view of multipathed devices

You can use the `vxdiskadm` command to control how a device is treated by the Dynamic Multipathing (DMP) feature of VxVM.

See [“Disabling multipathing and making devices invisible to VxVM”](#) on page 172.

## Cluster support

The Veritas Volume Manager software includes a licensable feature that enables it to be used in a cluster environment. The cluster functionality in Veritas Volume Manager allows multiple hosts to simultaneously access and manage a set of disks under Veritas Volume Manager control. A cluster is a set of hosts sharing a set of disks; each host is referred to as a node in the cluster.

See the *Veritas Storage Foundation Getting Started Guide*.

## Configuring shared disk groups

If you are installing Veritas Volume Manager for the first time or adding disks to an existing cluster, you need to configure new shared disks.

---

**Note:** RAID-5 volumes are not supported for sharing in a cluster.

---

If you are setting up Veritas Volume Manager for the first time, configure the shared disks using the following steps in the specified order:

- Start the cluster on one node only to prevent access by other nodes.

- On one node, run the `vxdiskadm` program and choose option 1 to initialize new disks. When asked to add these disks to a disk group, choose `none` to leave the disks for future use.
- On other nodes in the cluster, run `vxctl enable` to see the newly initialized disks.
- From the master node, create disk groups on the shared disks. To determine if a node is a master or slave, run the command `vxctl -c mode`.
- Use the `vxvg` command or VEA to create disk groups. If you use the `vxvg` command, specify the `-s` option to create shared disk groups.
- From the master node only, use `vxassist` or VEA to create volumes in the disk groups.
- If the cluster is only running with one node, bring up the other cluster nodes. Enter the `vxvg list` command on each node to display the shared disk groups.

## Converting existing VxVM disk groups to shared disk groups

### To convert existing disk groups to shared disk groups

- 1 Start the cluster on one node only to prevent access by other nodes.
- 2 Configure the disk groups using the following procedure.

To list all disk groups, use the following command:

```
# vxdg list
```

To deport the disk groups that are to be shared, use the following command:

```
# vxdg deport diskgroup
```

To import disk groups to be shared, use the following command:

```
# vxdg -s import diskgroup
```

This procedure marks the disks in the shared disk groups as shared and stamps them with the ID of the cluster, enabling other nodes to recognize the shared disks.

If dirty region logs exist, ensure they are active. If not, replace them with larger ones.

To display the shared flag for all the shared disk groups, use the following command:

```
# vxdg list
```

The disk groups are now ready to be shared.

- 3 Bring up the other cluster nodes. Enter the `vxdg list` command on each node to display the shared disk groups. This command displays the same list of shared disk groups displayed earlier.

See the *Veritas Storage Foundation Cluster File System Installation Guide*.

# Glossary

<b>Active/Active disk arrays</b>	This type of multipathed disk array allows you to access a disk in the disk array through all the paths to the disk simultaneously, without any performance degradation.
<b>Active/Passive disk arrays</b>	This type of multipathed disk array allows one path to a disk to be designated as primary and used to access the disk at any time. Using a path other than the designated active path results in severe performance degradation in some disk arrays.
<b>associate</b>	The process of establishing a relationship between VxVM objects; for example, a subdisk that has been created and defined as having a starting point within a plex is referred to as being associated with that plex.
<b>associated plex</b>	A plex associated with a volume.
<b>associated subdisk</b>	A subdisk associated with a plex.
<b>atomic operation</b>	<p>An operation that either succeeds completely or fails and leaves everything as it was before the operation was started. If the operation succeeds, all aspects of the operation take effect at once and the intermediate states of change are invisible. If any aspect of the operation fails, then the operation aborts without leaving partial changes.</p> <p>In a cluster, an atomic operation takes place either on all nodes or not at all.</p>
<b>attached</b>	A state in which a VxVM object is both associated with another object and enabled for use.
<b>block</b>	The minimum unit of data transfer to or from a disk or array.
<b>boot disk</b>	A disk that is used for the purpose of booting a system.
<b>boot disk group</b>	A private disk group that contains the disks from which the system may be booted.
<b>bootdg</b>	A reserved disk group name that is an alias for the name of the boot disk group.
<b>clean node shutdown</b>	The ability of a node to leave a cluster gracefully when all access to shared volumes has ceased.
<b>cluster</b>	A set of hosts (each termed a node) that share a set of disks.
<b>cluster manager</b>	An externally-provided daemon that runs on each node in a cluster. The cluster managers on each node communicate with each other and inform VxVM of changes in cluster membership.

<b>cluster-shareable disk group</b>	A disk group in which access to the disks is shared by multiple hosts (also referred to as a shared disk group).
<b>column</b>	A set of one or more subdisks within a striped plex. Striping is achieved by allocating data alternately and evenly across the columns within a plex.
<b>concatenation</b>	A layout style characterized by subdisks that are arranged sequentially and contiguously.
<b>configuration copy</b>	A single copy of a configuration database.
<b>configuration database</b>	A set of records containing detailed information on existing VxVM objects (such as disk and volume attributes).
<b>DCO (data change object)</b>	A VxVM object that is used to manage information about the FastResync maps in the DCO volume. Both a DCO object and a DCO volume must be associated with a volume to implement Persistent FastResync on that volume.
<b>data stripe</b>	This represents the usable data portion of a stripe and is equal to the stripe minus the parity region.
<b>DCO volume</b>	A special volume that is used to hold Persistent FastResync change maps and dirty region logs. See also see dirty region logging.
<b>detached</b>	A state in which a VxVM object is associated with another object, but not enabled for use.
<b>device name</b>	<p>The device name or address used to access a physical disk, such as <code>c0t0d0s2</code>. The <code>c#t#d#s#</code> syntax identifies the controller, target address, disk, and slice (or partition).</p> <p>In a SAN environment, it is more convenient to use enclosure-based naming, which forms the device name by concatenating the name of the enclosure (such as <code>enc0</code>) with the disk's number within the enclosure, separated by an underscore (for example, <code>enc0_2</code>). The term disk access name can also be used to refer to a device name.</p>
<b>dirty region logging</b>	The method by which the VxVM monitors and logs modifications to a plex as a bitmap of changed regions. For a volumes with a new-style DCO volume, the dirty region log (DRL) is maintained in the DCO volume. Otherwise, the DRL is allocated to an associated subdisk called a log subdisk.
<b>disabled path</b>	A path to a disk that is not available for I/O. A path can be disabled due to real hardware failures or if the user has used the <code>vxdmpadm disable</code> command on that controller.
<b>disk</b>	A collection of read/write data blocks that are indexed and can be accessed fairly quickly. Each disk has a universally unique identifier.
<b>disk access name</b>	An alternative term for a device name.

<b>disk access records</b>	Configuration records used to specify the access path to particular disks. Each disk access record contains a name, a type, and possibly some type-specific information, which is used by VxVM in deciding how to access and manipulate the disk that is defined by the disk access record.
<b>disk array</b>	A collection of disks logically arranged into an object. Arrays tend to provide benefits such as redundancy or improved performance.
<b>disk array serial number</b>	This is the serial number of the disk array. It is usually printed on the disk array cabinet or can be obtained by issuing a vendor-specific SCSI command to the disks on the disk array. This number is used by the DMP subsystem to uniquely identify a disk array.
<b>disk controller</b>	<p>In the multipathing subsystem of VxVM, the controller (host bus adapter or HBA) or disk array connected to the host, which the operating system represents as the parent node of a disk.</p> <p>For example, if a disk is represented by the device name <code>/dev/sbus@1f,0/QLGC,isp@2,10000/sd@8,0:c</code> then the path component <code>QLGC,isp@2,10000</code> represents the disk controller that is connected to the host for disk <code>sd@8,0:c</code>.</p>
<b>disk enclosure</b>	An intelligent disk array that usually has a backplane with a built-in Fibre Channel loop, and which permits hot-swapping of disks.
<b>disk group</b>	A collection of disks that share a common configuration. A disk group configuration is a set of records containing detailed information on existing VxVM objects (such as disk and volume attributes) and their relationships. Each disk group has an administrator-assigned name and an internally defined unique ID. The disk group names <code>bootdg</code> (an alias for the boot disk group), <code>defaultdg</code> (an alias for the default disk group) and <code>nodg</code> (represents no disk group) are reserved.
<b>disk group ID</b>	A unique identifier used to identify a disk group.
<b>disk ID</b>	A universally unique identifier that is given to each disk and can be used to identify the disk, even if it is moved.
<b>disk media name</b>	An alternative term for a disk name.
<b>disk media record</b>	A configuration record that identifies a particular disk, by disk ID, and gives that disk a logical (or administrative) name.
<b>disk name</b>	A logical or administrative name chosen for a disk that is under the control of VxVM, such as <code>disk03</code> . The term disk media name is also used to refer to a disk name.
<b>dissociate</b>	The process by which any link that exists between two VxVM objects is removed. For example, dissociating a subdisk from a plex removes the subdisk from the plex and adds the subdisk to the free space pool.

<b>dissociated plex</b>	A plex dissociated from a volume.
<b>dissociated subdisk</b>	A subdisk dissociated from a plex.
<b>distributed lock manager</b>	A lock manager that runs on different systems in a cluster, and ensures consistent access to distributed resources.
<b>enabled path</b>	A path to a disk that is available for I/O.
<b>encapsulation</b>	A process that converts existing partitions on a specified disk to volumes. If any partitions contain file systems, <code>/etc/vfstab</code> entries are modified so that the file systems are mounted on volumes instead.
<b>enclosure</b>	See disk enclosure.
<b>enclosure-based naming</b>	See device name.
<b>fabric mode disk</b>	A disk device that is accessible on a Storage Area Network (SAN) via a Fibre Channel switch.
<b>FastResync</b>	A fast resynchronization feature that is used to perform quick and efficient resynchronization of stale mirrors, and to increase the efficiency of the snapshot mechanism.
<b>Fibre Channel</b>	A collective name for the fiber optic technology that is commonly used to set up a Storage Area Network (SAN).
<b>file system</b>	A collection of files organized together into a structure. The UNIX file system is a hierarchical structure consisting of directories and files.
<b>free space</b>	An area of a disk under VxVM control that is not allocated to any subdisk or reserved for use by any other VxVM object.
<b>free subdisk</b>	A subdisk that is not associated with any plex and has an empty <code>putil[0]</code> field.
<b>hostid</b>	A string that identifies a host to VxVM. The host ID for a host is stored in its <code>volboot</code> file, and is used in defining ownership of disks and disk groups.
<b>hot-relocation</b>	A technique of automatically restoring redundancy and access to mirrored and RAID-5 volumes when a disk fails. This is done by relocating the affected subdisks to disks designated as spares and/or free space in the same disk group.
<b>hot-swap</b>	Refers to devices that can be removed from, or inserted into, a system without first turning off the power supply to the system.
<b>initiating node</b>	The node on which the system administrator is running a utility that requests a change to VxVM objects. This node initiates a volume reconfiguration.
<b>JBOD (just a bunch of disks)</b>	The common name for an unintelligent disk array which may, or may not, support the hot-swapping of disks.
<b>log plex</b>	A plex used to store a RAID-5 log. The term log plex may also be used to refer to a Dirty Region Logging plex.



<b>log subdisk</b>	A subdisk that is used to store a dirty region log.
<b>master node</b>	A node that is designated by the software to coordinate certain VxVM operations in a cluster. Any node is capable of being the master node.
<b>mastering node</b>	The node to which a disk is attached. This is also known as a disk owner.
<b>mirror</b>	A duplicate copy of a volume and the data therein (in the form of an ordered collection of subdisks). Each mirror consists of one plex of the volume with which the mirror is associated.
<b>mirroring</b>	A layout technique that mirrors the contents of a volume onto multiple plexes. Each plex duplicates the data stored on the volume, but the plexes themselves may have different layouts.
<b>multipathing</b>	Where there are multiple physical access paths to a disk connected to a system, the disk is called multipathed. Any software residing on the host, (for example, the DMP driver) that hides this fact from the user is said to provide multipathing functionality.
<b>node</b>	One of the hosts in a cluster.
<b>node abort</b>	A situation where a node leaves a cluster (on an emergency basis) without attempting to stop ongoing operations.
<b>node join</b>	The process through which a node joins a cluster and gains access to shared disks.
<b>Non-Persistent FastResync</b>	A form of FastResync that cannot preserve its maps across reboots of the system because it stores its change map in memory.
<b>object</b>	An entity that is defined to and recognized internally by VxVM. The VxVM objects are: volume, plex, subdisk, disk, and disk group. There are actually two types of disk objects—one for the physical aspect of the disk and the other for the logical aspect.
<b>parity</b>	A calculated value that can be used to reconstruct data after a failure. While data is being written to a RAID-5 volume, parity is also calculated by performing an exclusive OR (XOR) procedure on data. The resulting parity is then written to the volume. If a portion of a RAID-5 volume fails, the data that was on that portion of the failed volume can be recreated from the remaining data and the parity.
<b>parity stripe unit</b>	A RAID-5 volume storage region that contains parity information. The data contained in the parity stripe unit can be used to help reconstruct regions of a RAID-5 volume that are missing because of I/O or disk failures.
<b>partition</b>	The standard division of a physical disk device, as supported directly by the operating system and disk drives.
<b>path</b>	When a disk is connected to a host, the path to the disk consists of the HBA (Host Bus Adapter) on the host, the SCSI or fibre cable connector and the controller on the disk or disk array. These components constitute a path to a disk. A failure on

any of these results in DMP trying to shift all I/O for that disk onto the remaining (alternate) paths.

<b>pathgroup</b>	In the case of disks which are not multipathed by <code>vxdmp</code> , VxVM will see each path as a disk. In such cases, all paths to the disk can be grouped. This way only one of the paths from the group is made visible to VxVM.
<b>Persistent FastResync</b>	A form of FastResync that can preserve its maps across reboots of the system by storing its change map in a DCO volume on disk).
<b>persistent state logging</b>	A logging type that ensures that only active mirrors are used for recovery purposes and prevents failed mirrors from being selected for recovery. This is also known as kernel logging.
<b>physical disk</b>	The underlying storage device, which may or may not be under VxVM control.
<b>plex</b>	A plex is a logical grouping of subdisks that creates an area of disk space independent of physical disk size or other restrictions. Mirroring is set up by creating multiple data plexes for a single volume. Each data plex in a mirrored volume contains an identical copy of the volume data. Plexes may also be created to represent concatenated, striped and RAID-5 volume layouts, and to store volume logs.
<b>primary path</b>	In Active/Passive disk arrays, a disk can be bound to one particular controller on the disk array or owned by a controller. The disk can then be accessed using the path through this particular controller.
<b>private disk group</b>	A disk group in which the disks are accessed by only one specific host in a cluster.
<b>private region</b>	A region of a physical disk used to store private, structured VxVM information. The private region contains a disk header, a table of contents, and a configuration database. The table of contents maps the contents of the disk. The disk header contains a disk ID. All data in the private region is duplicated for extra reliability.
<b>public region</b>	A region of a physical disk managed by VxVM that contains available space and is used for allocating subdisks.
<b>RAID (redundant array of independent disks)</b>	A disk array set up with part of the combined storage capacity used for storing duplicate information about the data stored in that array. This makes it possible to regenerate the data if a disk failure occurs.
<b>read-writeback mode</b>	A recovery mode in which each read operation recovers plex consistency for the region covered by the read. Plex consistency is recovered by reading data from blocks of one plex and writing the data to all other writable plexes.
<b>root configuration</b>	The configuration database for the root disk group. This is special in that it always contains records for other disk groups, which are used for backup purposes only. It also contains disk records that define all disk devices on the system.
<b>root disk</b>	The disk containing the root file system. This disk may be under VxVM control.

<b>root file system</b>	The initial file system mounted as part of the UNIX kernel startup sequence.
<b>root partition</b>	The disk region on which the root file system resides.
<b>root volume</b>	The VxVM volume that contains the root file system, if such a volume is designated by the system configuration.
<b>rootability</b>	The ability to place the <code>root</code> file system and the <code>swap</code> device under VxVM control. The resulting volumes can then be mirrored to provide redundancy and allow recovery in the event of disk failure.
<b>secondary path</b>	In Active/Passive disk arrays, the paths to a disk other than the primary path are called secondary paths. A disk is supposed to be accessed only through the primary path until it fails, after which ownership of the disk is transferred to one of the secondary paths.
<b>sector</b>	<p>A unit of size, which can vary between systems. Sector size is set per device (hard drive, CD-ROM, and so on). Although all devices within a system are usually configured to the same sector size for interoperability, this is not always the case.</p> <p>A sector is commonly 512 bytes.</p>
<b>shared disk group</b>	A disk group in which access to the disks is shared by multiple hosts (also referred to as a cluster-shareable disk group).
<b>shared volume</b>	A volume that belongs to a shared disk group and is open on more than one node of a cluster at the same time.
<b>shared VM disk</b>	A VM disk that belongs to a shared disk group in a cluster.
<b>slave node</b>	A node that is not designated as the master node of a cluster.
<b>slice</b>	The standard division of a logical disk device. The terms partition and slice are sometimes used synonymously.
<b>snapshot</b>	A point-in-time copy of a volume (volume snapshot) or a file system (file system snapshot).
<b>spanning</b>	A layout technique that permits a volume (and its file system or database) that is too large to fit on a single disk to be configured across multiple physical disks.
<b>sparse plex</b>	A plex that is not as long as the volume or that has holes (regions of the plex that do not have a backing subdisk).
<b>SAN (storage area network)</b>	A networking paradigm that provides easily reconfigurable connectivity between any subset of computers, disk storage and interconnecting hardware such as switches, hubs and bridges.
<b>stripe</b>	A set of stripe units that occupy the same positions across a series of columns.
<b>stripe size</b>	The sum of the stripe unit sizes comprising a single stripe across all columns being striped.

<b>stripe unit</b>	Equally-sized areas that are allocated alternately on the subdisks (within columns) of each striped plex. In an array, this is a set of logically contiguous blocks that exist on each disk before allocations are made from the next disk in the array. A stripe unit may also be referred to as a stripe element.
<b>stripe unit size</b>	The size of each stripe unit. The default stripe unit size is 64KB. The stripe unit size is sometimes also referred to as the stripe width.
<b>striping</b>	A layout technique that spreads data across several physical disks using stripes. The data is allocated alternately to the stripes within the subdisks of each plex.
<b>subdisk</b>	A consecutive set of contiguous disk blocks that form a logical disk segment. Subdisks can be associated with plexes to form volumes.
<b>swap area</b>	A disk region used to hold copies of memory pages swapped out by the system pager process.
<b>swap volume</b>	A VxVM volume that is configured for use as a swap area.
<b>transaction</b>	A set of configuration changes that succeed or fail as a group, rather than individually. Transactions are used internally to maintain consistent configurations.
<b>VM disk</b>	A disk that is both under VxVM control and assigned to a disk group. VM disks are sometimes referred to as VxVM disks.
<b>volboot file</b>	A small file that is used to locate copies of the boot disk group configuration. The file may list disks that contain configuration copies in standard locations, and can also contain direct pointers to configuration copy locations. The <code>volboot</code> file is stored in a system-dependent location.
<b>volume</b>	A virtual disk, representing an addressable range of disk blocks used by applications such as file systems or databases. A volume is a collection of from one to 32 plexes.
<b>volume configuration device</b>	The volume configuration device ( <code>/dev/vx/config</code> ) is the interface through which all configuration changes to the volume device driver are performed.
<b>volume device driver</b>	The driver that forms the virtual disk drive between the application and the physical device driver level. The volume device driver is accessed through a virtual disk device node whose character device nodes appear in <code>/dev/vx/rdisk</code> , and whose block device nodes appear in <code>/dev/vx/dsk</code> .
<b>volume event log</b>	The device interface ( <code>/dev/vx/event</code> ) through which volume driver events are reported to utilities.
<b>vxconfigd</b>	The VxVM configuration daemon, which is responsible for making changes to the VxVM configuration. This daemon must be running before VxVM operations can be performed.

# Index

## Symbols

- /dev/vx/dmp directory 167
- /dev/vx/rdmp directory 167
- /etc/default/vxassist file 309, 480
- /etc/default/vxdg file 226, 494
- /etc/default/vxdisk file 87, 115
- /etc/default/vxencap file 115
- /etc/init.d/vxvm-recover file 486
- /etc/vfstab file 372
- /etc/volboot file 275
- /etc/vx/darecs file 275
- /etc/vx/dmppolicy.info file 201
- /etc/vx/volboot file 234
- /kernel/drv/vxio.conf file 554–555
- /kernel/drv/vxspec.conf file 556
- /lib/svc/method/vxvm-recover file 486

## A

- A/A disk arrays 166
- A/A-A disk arrays 166
- A/P disk arrays 166
- A/P-C disk arrays 167
- A/PF disk arrays 166
- A/PF-C disk arrays 167
- A/PG disk arrays 167
- A/PG-C disk arrays 167
- A5x00 arrays
  - removing and replacing disks 154
- access port 166
- activation modes for shared disk groups 493–494
- ACTIVE
  - plex state 291
  - volume state 340
- active path attribute 197
- active paths
  - devices 198–199
- ACTIVE state 394
- Active/Active disk arrays 166
- Active/Passive disk arrays 166
- adaptive load-balancing 201
- adding disks 124

- alignment constraints 312
- allocation
  - site-based 526
- APM
  - configuring 216
- array policy module (APM)
  - configuring 216
- array ports
  - disabling for DMP 207
  - displaying information about 187
  - enabling for DMP 208
- array support library (ASL) 90
- Array Volume ID
  - device naming 109
- arrays
  - DMP support 89
- ASL
  - array support library 89–90
- Asymmetric Active/Active disk arrays 166
- ATTACHING state 394
- attributes
  - active 197
  - autogrow 404, 406
  - autogrowby 404
  - cache 406
  - cachesize 406
  - comment 288, 300
  - dcolen 67, 322, 442
  - default for disk initialization 115
  - default for encapsulation 115
  - dgalen\_checking 312
  - drl 324, 369
  - fastresync 322, 324, 375
  - for specifying storage 313
  - hasdcolog 375
  - highwatermark 404
  - init 334
  - len 288
  - loglen 325
  - logtype 324
  - maxautogrow 404
  - maxdev 238

attributes (*continued*)

- mirdg 414
- mirvol 414
- name 287, 300
- ncachemirror 406
- ndcomirror 322, 324, 442
- ndcomirs 361, 402
- newvol 412
- nmirror 412
- nomannual 197
- nopreferred 197
- plex 300
- preferred priority 198
- primary 198
- putil 287, 300
- secondary 198
- sequential DRL 324
- setting for paths 197, 199
- snapvol 408, 414
- source 408, 414
- standby 198
- subdisk 287
- syncing 400, 426
- tutil 288, 300

- auto disk type 85

## autogrow

- tuning 428

- autogrow attribute 404, 406

- autogrowby attribute 404

- autotrespass mode 166

**B**

## backups

- created using snapshots 400
- creating for volumes 388
- creating using instant snapshots 400
- creating using third-mirror snapshots 431
- for multiple volumes 415, 436
- implementing online 457
- of disk group configuration 276

- balanced path policy 202

- base minor number 236

- blocks on disks 33

## boot command

- a flag 137
- syntax 137

## boot disk

- encapsulating 134
- listing volumes on 137

boot disk (*continued*)

- mirroring 134
- unencapsulating 141

- boot disk group 222

## boot disks

- alternate 135

- boot-time restrictions 133

- bootdg 222

- booting root volumes 132–133

- break-off snapshots

- emulation of 393

- BROKEN state 394

**C**

- c# 24, 83

- c#t#d#s# 83

- c#t#d#s# based naming 83

- c0d0t0 84

- cache attribute 406

## cache objects

- creating 403

- enabling 404

- listing snapshots in 428

## caches

- creating 403

- deleting 430

- finding out snapshots configured on 430

- growing 430

- listing snapshots in 428

- removing 430

- resizing 430

- shrinking 430

- stopping 431

- used by space-optimized instant snapshots 392

- cachesize attribute 406

## Campus Cluster feature

- administering 525

## campus clusters

- administering 525

- serial split brain condition in 250

- cascade instant snapshots 395

## cascaded snapshot hierarchies

- creating 419

## categories

- disks 90

## CDS

- alignment constraints 312

- compatible disk groups 226

- disk format 86

- cds attribute 226
- cdsdisk format 86
- check\_all policy 214
- check\_alternate policy 215
- check\_disabled policy 215
- check\_periodic policy 215
- checkpoint interval 557
- CLEAN
  - plex state 291
  - volume state 340
- clone\_disk flag 240
- cloned disks 239-240
- cluster functionality
  - enabling 610
  - shared disks 610
- cluster protocol version
  - checking 523
  - upgrading 523
- cluster-shareable disk groups in clusters 492
- clusters
  - activating disk groups 494
  - activating shared disk groups 520
  - activation modes for shared disk groups 493
  - benefits 503
  - checking cluster protocol version 522
  - cluster-shareable disk groups 492
  - configuration 505
  - configuring exclusive open of volume by node 521
  - connectivity policies 495
  - converting shared disk groups to private 519
  - creating shared disk groups 517
  - designating shareable disk groups 492
  - detach policies 495
  - determining if disks are shared 516
  - forcibly adding disks to disk groups 518
  - forcibly importing disk groups 518
  - importing disk groups as shared 518
  - initialization 505
  - introduced 489
  - limitations of shared disk groups 500
  - listing shared disk groups 516
  - maximum number of nodes in 504
  - moving objects between disk groups 519
  - node shutdown 512
  - nodes 490
  - operation of DRL in 513-514
  - operation of vxconfig in 510
  - operation of VxVM in 490
- clusters (*continued*)
  - private disk groups 492
  - private networks 491
  - protection against simultaneous writes 493
  - reconfiguration of 505
  - resolving disk status in 495
  - setting disk connectivity policies in 520
  - setting failure policies in 521
  - shared disk groups 492
  - shared objects 493
  - splitting disk groups in 519
  - upgrading cluster protocol version 523
  - use of DMP in 171
  - vol\_fmr\_logsz tunable 558
  - volume reconfiguration 508
  - vxclust 506
  - vxclustadm 507
  - vxctl 515
  - vxrecover 523
  - vxstat 523
- columns
  - changing number of 379
  - in striping 40
  - mirroring in striped-mirror volumes 327
- CommandCentral Storage 73
- comment
  - plex attribute 300
  - subdisk attribute 288
- concatenated volumes 38, 304
- concatenated-mirror volumes
  - converting to mirrored-concatenated 383
  - creating 320
  - defined 46
  - recovery 305
- concatenation 38
- condition flags for plexes 293
- configuration backup and restoration 276
- configuration changes
  - monitoring using vxnotify 276
- configuration copies for disk group 555
- configuration database
  - copy size 221
  - in private region 85
  - listing disks with 242
  - metadata 241
  - reducing size of 256
- configuring
  - shared disks 610

connectivity policies 495  
 setting for disk groups 520

#### Controller ID

displaying 186

#### controllers

disabling for DMP 207  
 disabling in DMP 174  
 displaying information about 185  
 enabling for DMP 208  
 mirroring across 318, 327  
 mirroring guidelines 606  
 number 24  
 specifying to vxassist 313  
 upgrading firmware 208

#### copy-on-write

used by instant snapshots 391

#### copymaps 67

#### Cross-platform Data Sharing (CDS)

alignment constraints 312  
 disk format 86

#### customized naming

DMP nodes 178

#### CVM

cluster functionality of VxVM 503

## D

d# 24, 83

#### data change object

DCO 67

data redundancy 43–44, 47

data volume configuration 61

database replay logs and sequential DRL 60

#### databases

resilvering 60  
 resynchronizing 60

#### DCO

adding to RAID-5 volumes 363  
 adding version 0 DCOs to volumes 440  
 adding version 20 DCOs to volumes 361  
 calculating plex size for version 20 68  
 considerations for disk layout 262  
 creating volumes with version 0 DCOs  
 attached 321  
 creating volumes with version 20 DCOs  
 attached 324  
 data change object 67  
 determining version of 363  
 dissociating version 0 DCOs from volumes 444  
 effect on disk group split and join 262

#### DCO (*continued*)

log plexes 69  
 log volume 67  
 moving log plexes 363, 443  
 reattaching version 0 DCOs to volumes 444  
 removing version 0 DCOs from volumes 444  
 specifying storage for version 0 plexes 443  
 specifying storage for version 20 plexes 362  
 used with DRL 59  
 version 0 67  
 version 20 67  
 versioning 67

dcolen attribute 67, 322, 442

#### DCOSNP

plex state 291

DDI\_NT\_FABRIC property 88

#### DDL 27

Device Discovery Layer 92

#### decision support

implementing 461

default disk group 222

defaulttg 222–223

#### defaults

for vxdisk 87, 115  
 for vxencap 115

description file with vxmake 333

#### detach policy

global 497  
 local 497

#### DETACHED

plex kernel state 294  
 volume kernel state 341

#### device discovery

introduced 27  
 partial 88

Device Discovery Layer 92

Device Discovery Layer (DDL) 27, 92

device files to access volumes 335, 609

device names 24, 82

configuring persistent 110  
 user-specified 178

#### device nodes

controlling access for volume sets 453  
 displaying access for volume sets 453  
 enabling access for volume sets 452  
 for volume sets 451

#### devices

adding foreign 104  
 fabric 88



devices (*continued*)

- JBOD 89
- listing all 93
- metadevices 83
- nopriv 130
- path redundancy 198–199
- pathname 83
- volatile 124
- dgalign\_checking attribute 312
- dgfailpolicy attribute 500
- dirty flags set on volumes 58
- dirty region logging.. *See* DRL
- dirty regions 562
- disable failure policy 499
- DISABLED
  - plex kernel state 294
  - volume kernel state 341
- disabled paths 177
- disk access records
  - stored in /etc/vx/darecs 275
- disk arrays
  - A/A 166
  - A/A-A 166
  - A/P 166
  - A/P-C 167
  - A/PF 166
  - A/PF-C 167
  - A/PG 167
  - A/PG-C 167
  - Active/Active 166
  - Active/Passive 166
  - adding disks to DISKS category 101
  - Asymmetric Active/Active 166
  - defined 25
  - excluding support for 99
  - JBOD devices 89
  - listing excluded 99
  - listing supported 98
  - listing supported disks in DISKS category 99
  - multipathed 26
  - re-including support for 99
  - removing disks from DISKS category 103
  - supported with DMP 98
- disk drives
  - variable geometry 607
- disk duplexing 327
- disk groups
  - activating shared 520
  - activation in clusters 494

disk groups (*continued*)

- adding disks to 227
- avoiding conflicting minor numbers on
  - import 236
- boot disk group 222
- bootdg 222
- clearing locks on disks 234
- cluster-shareable 492
- compatible with CDS 226
- configuration backup and restoration 276
- configuring site consistency on 533
- configuring site-based allocation on 532
- converting to private 519
- creating 220
- creating shared 517
- creating with old version number 274
- default disk group 222
- defaultdg 222
- defaults file for shared 494
- defined 32
- deporting 229
- designating as shareable 492
- destroying 269
- determining the default disk group 222
- disabling 269
- displaying boot disk group 223
- displaying default disk group 223
- displaying free space in 225
- displaying information about 224
- displaying version of 274
- effect of size on private region 221
- elimination of rootdg 221
- failure policy 499
- features supported by version 272
- forcing import of 235
- free space in 473
- impact of number of configuration copies on
  - performance 555
- importing 230
- importing as shared 518
- importing forcibly 518
- importing with cloned disks 240
- ISP 277
- joining 258, 267
- layout of DCO plexes 262
- limitations of move
  - split. *See* and join
- listing objects affected by a move 261
- listing shared 516

disk groups *(continued)*

- making site consistent 531
- moving between systems 233
- moving disks between 228, 264
- moving licensed EMC disks between 264
- moving objects between 257, 263
- moving objects in clusters 519
- names reserved by system 222
- nodg 222
- private in clusters 492
- recovering destroyed 270
- recovery from failed reconfiguration 260
- removing disks from 227
- renaming 248
- reorganizing 256
- reserving minor numbers 236
- restarting moved volumes 265, 267–268
- root 32
- rootdg 32, 221
- serial split brain condition 250
- setting connectivity policies in clusters 520
- setting default disk group 223
- setting failure policies in clusters 521
- setting number of configuration copies 555
- shared in clusters 492
- specifying to commands 222
- splitting 257, 266
- splitting in clusters 519
- upgrading version of 270, 274
- version 270, 274

disk media names 32, 82

disk names 82

- configuring persistent 110

disk## 33

disk##-## 33

diskdetspolicy attribute 500

diskgroup## 82

disks 90

- adding 124
- adding to disk groups 227
- adding to disk groups forcibly 518
- adding to DISKS category 101
- array support library 90
- auto-configured 85
- c0t0d0 84
- categories 90
- CDS format 86
- changing default layout attributes 115
- changing naming scheme 107

disks *(continued)*

- clearing locks on 234
- cloned 240
- complete failure messages 472
- configuring persistent names 110
- default encapsulation values 115
- default initialization values 115
- determining failed 472
- determining if shared 516
- Device Discovery Layer 92
- disabled path 177
- discovery of by VxVM 87, 89
- disk access records file 275
- disk arrays 25
- displaying information 142–143
- displaying information about 142, 225
- displaying naming scheme 109
- displaying spare 476
- dynamic LUN expansion 144
- enabled path 177
- enabling 155
- enabling after hot swap 155
- encapsulating 105
- encapsulation 126, 131
- enclosures 27
- excluding free space from hot-relocation use 478
- failure handled by hot-relocation 469
- formatting 114
- handling clones 239
- handling duplicated identifiers 239
- hot-relocation 467
- initializing 105, 115
- installing 114
- invoking discovery of 91
- layout of DCO plexes 262
- listing tags on 241
- listing those supported in JBODs 99
- making available for hot-relocation 476
- making free space available for hot-relocation use 479
- marking as spare 476
- media name 82
- metadevices 83
- mirroring boot disk 134
- mirroring root disk 134
- mirroring volumes on 356
- moving between disk groups 228, 264
- moving disk groups between systems 233
- moving volumes from 373

disks (*continued*)

- names 82
  - naming schemes 83
  - nopriv 86
  - nopriv devices 130
  - number 24
  - obtaining performance statistics 551
  - OTHER\_DISKS category 90
  - partial failure messages 471
  - postponing replacement 148
  - primary path 177
  - putting under control of VxVM 105
  - reinitializing 123
  - releasing from disk groups 269
  - removing 145, 148
  - removing from A5x00 arrays 154
  - removing from disk groups 227
  - removing from DISKS category 103
  - removing from pool of hot-relocation spares 478
  - removing from VxVM control 147, 228
  - removing tags from 242
  - removing with subdisks 147
  - renaming 156
  - replacing 148
  - replacing in A5x00 arrays 154
  - replacing removed 152
  - reserving for special purposes 157
  - resolving status in clusters 495
  - root disk 131
  - scanning for 87
  - secondary path 177
  - setting connectivity policies in clusters 520
  - setting failure policies in clusters 521
  - setting tags on 241
  - simple 86
  - simple format 86
  - sliced 86
  - sliced format 86
  - spare 473
  - specifying to vxassist 313
  - stripe unit size 607
  - tagging with site name 536
  - taking offline 156
  - UDID flag 239
  - unique identifier 239
  - unreserving 158
  - upgrading controller firmware 208
  - VM 32
  - writing a new identifier to 240
- DISKS category 90
    - adding disks 101
    - listing supported disks 99
    - removing disks 103
  - displaying
    - DMP nodes 181
    - HBA information 186
    - redundancy levels 198
    - supported disk arrays 98
  - displaying statistics
    - erroneous I/Os 194
    - queued I/Os 194
  - DMP
    - booting from DMP devices 171
    - check\_all restore policy 214
    - check\_alternate restore policy 215
    - check\_disabled restore policy 215
    - check\_periodic restore policy 215
    - configuring DMP path restoration policies 214
    - configuring I/O throttling 211
    - configuring response to I/O errors 210, 213
    - disabling array ports 207
    - disabling controllers 207
    - disabling multipathing 172
    - disabling paths 207
    - displaying DMP database information 175
    - displaying DMP node for a path 180
    - displaying DMP node for an enclosure 180–181
    - displaying DMP nodes 181
    - displaying information about array ports 187
    - displaying information about controllers 185
    - displaying information about enclosures 186
    - displaying information about paths 175
    - displaying LUN group for a node 182
    - displaying paths controlled by DMP node 183
    - displaying paths for a controller 184
    - displaying paths for an array port 184
    - displaying recoveryoption values 213
    - displaying status of DMP error handling
      - thread 216
    - displaying status of DMP path restoration
      - thread 216
    - displaying TPD information 187
    - dynamic multipathing 165
    - enabling array ports 208
    - enabling controllers 208
    - enabling multipathing 174
    - enabling paths 208
    - enclosure-based naming 168

**DMP** (*continued*)

- gathering I/O statistics 191
- in a clustered environment 171
- load balancing 170
- logging levels 568
- metanodes 167
- nodes 167
- path aging 568
- path failover mechanism 169
- path-switch tunable 570
- renaming an enclosure 209
- restore policy 214
- scheduling I/O on secondary paths 204
- setting the DMP restore polling interval 214
- stopping the DMP restore daemon 216
- vxmpadm 179

**DMP nodes**

- displaying consolidated information 181
- setting names 178

**DMP support**

- JBOD devices 89

- dmp\_cache\_open tunable 566
- dmp\_daemon\_count tunable 566
- dmp\_delayq\_interval tunable 567
- dmp\_failed\_io\_threshold tunable 567
- dmp\_fast\_recovery tunable 567
- dmp\_health\_time tunable 568
- dmp\_log\_level tunable 568
- dmp\_path\_age tunable 570
- dmp\_pathswitch\_blks\_shift tunable 570
- dmp\_probe\_idle\_lun tunable 571
- dmp\_queue\_depth tunable 571
- dmp\_retry\_count tunable 572
- dmp\_scsi\_timeout tunable 573
- dmp\_stat\_interval tunable 573

**DR**

- dynamic reconfiguration 171

**DRL**

- adding log subdisks 285
- adding logs to mirrored volumes 366
- creating volumes with DRL enabled 324
- determining if active 365
- determining if enabled 364
- dirty region logging 59
- disabling 365
- enabling on volumes 361
- handling recovery in clusters 514
- hot-relocation limitations 469
- log subdisks 59

**DRL** (*continued*)

- maximum number of dirty regions 562
- minimum number of sectors 562
- operation in clusters 513
- re-enabling 365
- recovery map in version 20 DCO 68
- removing logs from mirrored volumes 367
- removing support for 365
- sequential 60
  - use of DCO with 59
- drl attribute 324, 369
- DRL guidelines 606
- duplexing 327
- dynamic LUN expansion 144
- dynamic reconfiguration 171

**E****EMC arrays**

- moving disks between disk groups 264

**EMC PowerPath**

- coexistence with DMP 91

**EMC Symmetrix**

- autodiscovery 91

**EMPTY**

- plex state 291
- volume state 340

**ENABLED**

- plex kernel state 294
- volume kernel state 341

**enabled paths**

- displaying 177

**encapsulating disks 126, 131****encapsulation**

- default attributes 115
- failure of 129
- of disks 105

**enclosure-based naming 27, 84, 107**

- displayed by vxprint 114
- DMP 168

**enclosures 27**

- discovering disk access names in 114
- displaying information about 186
- issues with nopriv disks 112
- issues with simple disks 112
- mirroring across 327
- path redundancy 198–199
- setting attributes of paths 197, 199
- tagging with site name 537, 540

- erroneous I/Os
    - displaying statistics 194
  - error messages
    - Association count is incorrect 503
    - Association not resolved 503
    - Cannot auto-import group 502
    - Configuration records are inconsistent 503
    - Disk for disk group not found 235
    - Disk group has no valid configuration
      - copies 235, 503
    - Disk group version doesn't support feature 271
    - Disk is in use by another host 234
    - Disk is used by one or more subdisks 227
    - Disk not moving
      - but subdisks on it are 261
    - Duplicate record in configuration 503
    - import failed 234
    - It is not possible to encapsulate 129
    - No valid disk found containing disk group 234
    - The encapsulation operation failed 129
    - tmpsize too small to perform this relayout 54
    - unsupported layout 129
    - Volume has different organization in each
      - mirror 353
      - vx dg listmove failed 261
  - errord daemon 169
  - exclusive-write mode 494
  - exclusivewrite mode 493
  - explicit failover mode 166
- F**
- fabric devices 88
  - FAILFAST flag 169
  - failover 489, 504
  - failover mode 166
  - failure handled by hot-relocation 469
  - failure in RAID-5 handled by hot-relocation 469
  - failure policies 499
    - setting for disk groups 521
  - FastResync
    - checking if enabled on volumes 375
    - disabling on volumes 375
    - effect of growing volume on 71
    - enabling on new volumes 322
    - enabling on volumes 374
    - limitations 72
    - Non-Persistent 66
    - Persistent 66, 68
    - size of bitmap 558
  - FastResync (*continued*)
    - snapshot enhancements 389
    - use with snapshots 65
  - fastresync attribute 322, 324, 375
  - file systems
    - growing using vxresize 352
    - mirroring on root disk 137
    - permitted resizing operations 352
    - shrinking using vxresize 352
    - unmounting 372
  - fire drill
    - defined 526
    - testing 533
  - firmware
    - upgrading 208
  - FMR.. *See* FastResync
  - foreign devices
    - adding 104
  - formatting disks 114
  - free space in disk groups 473
  - full-sized instant snapshots 390
    - creating 408
    - creating volumes for use as 405
  - fullinst snapshot type 426
- G**
- global detach policy 497
  - guidelines
    - DRL 606
    - mirroring 605
    - RAID-5 608
- H**
- hasdcolog attribute 375
  - HBA information
    - displaying 186
  - HBAs
    - listing ports 94
    - listing supported 94
    - listing targets 95
  - highwatermark attribute 404
  - host failures 541
  - hot-relocation
    - complete failure messages 472
    - configuration summary 475
    - daemon 468
    - defined 73
    - detecting disk failure 469

**hot-relocation** (*continued*)

- detecting plex failure 469
- detecting RAID-5 subdisk failure 469
- excluding free space on disks from use by 478
- limitations 469
- making free space on disks available for use by 479
- marking disks as spare 476
- modifying behavior of 486
- notifying users other than root 487
- operation of 467
- partial failure messages 471
- preventing from running 487
- reducing performance impact of recovery 487
- removing disks from spare pool 478
- subdisk relocation 474
- subdisk relocation messages 480
- unrelocating subdisks 480
- unrelocating subdisks using vxassist 482
- unrelocating subdisks using vxdiskadm 481
- unrelocating subdisks using vxunreloc 483
- use of free space in disk groups 473
- use of spare disks 473
- use of spare disks and free space 474
- using only spare disks for 480
- vxrelocd 468

**I****I/O**

- gathering statistics for DMP 191
- kernel threads 23
- scheduling on secondary paths 204
- throttling 169
- use of statistics in performance tuning 550
- using traces for performance tuning 553

**I/O operations**

- maximum size of 560

**I/O policy**

- displaying 200
- example 204
- specifying 200

**I/O throttling** 211**I/O throttling options**

- configuring 213

**identifiers for tasks** 342**idle LUNs** 571**implicit failover mode** 166**init attribute** 334**initialization**

- default attributes 115
- of disks 105, 115

**initialization of disks** 105**instant snapshots**

- backing up multiple volumes 415
- cascaded 395
- creating backups 400
- creating for volume sets 416
- creating full-sized 408
- creating space-optimized 406
- creating volumes for use as full-sized 405
- displaying information about 424
- dissociating 423
- full-sized 390
- improving performance of synchronization 427
- reattaching 420
- refreshing 420
- removing 423
- removing support for 365
- restoring volumes using 422
- space-optimized 392
- splitting hierarchies 424
- synchronizing 426

**intent logging** 388**INVALID volume state** 340**ioctl calls** 560–561**IOFAIL plex condition** 293**IOFAIL plex state** 291**iSCSI parameters**

- administering with DDL 97
- setting with vxddladm 97

**ISP**

- disk groups 277

**ISP disk group**

- Upgrading 277

**J****JBOD**

- DMP support 89

**JBODs**

- adding disks to DISKS category 101
- listing supported disks 99
- removing disks from DISKS category 103

**K****kernel states**

- for plexes 294

kernel states (*continued*)  
 volumes 341

## L

layered volumes  
 converting to non-layered 383  
 defined 51, 305  
 striped-mirror 45  
 layout attributes  
 changing for disks 115  
 layouts  
 changing default used by vxassist 312  
 left-symmetric 49  
 specifying default 312  
 types of volume 304  
 leave failure policy 499  
 left-symmetric layout 49  
 len subdisk attribute 288  
 link objects 394  
 linked break-off snapshots 394  
 creating 413  
 linked third-mirror snapshots  
 reattaching 421  
 listing  
 alternate boot disks 135  
 DMP nodes 181  
 supported disk arrays 98  
 load balancing 166  
 across nodes in a cluster 489  
 displaying policy for 200  
 specifying policy for 200  
 local detach policy 497  
 lock clearing on disks 234  
 LOG plex state 291  
 log subdisks 606  
 associating with plexes 285  
 DRL 59  
 logdisk 323, 330  
 logical units 166  
 loglen attribute 325  
 logs  
 adding DRL log 366  
 adding for RAID-5 384  
 adding sequential DRL logs 366  
 adding to volumes 360  
 RAID-5 51, 58  
 removing DRL log 367  
 removing for RAID-5 385  
 removing sequential DRL logs 367

logs (*continued*)  
 resizing using vxvol 355  
 specifying number for RAID-5 329  
 usage with volumes 306  
 logtype attribute 324  
 LUN 166  
 LUN expansion 144  
 LUN group failover 167  
 LUN groups  
 displaying details of 182  
 LUNs  
 idle 571

## M

maps  
 adding to volumes 360  
 usage with volumes 306  
 master node  
 defined 491  
 discovering 515  
 maxautogrow attribute 404  
 maxdev attribute 238  
 memory  
 granularity of allocation by VxVM 562  
 maximum size of pool for VxVM 563  
 minimum size of pool for VxVM 565  
 persistence of FastResync in 66  
 messages  
 complete disk failure 472  
 hot-relocation of subdisks 480  
 partial disk failure 471  
 metadata 241  
 metadevices 83  
 metanodes  
 DMP 167  
 minimum queue load balancing policy 202  
 minimum redundancy levels  
 displaying for a device 198  
 specifying for a device 199  
 minor numbers 236  
 mirbrk snapshot type 426  
 mirdg attribute 414  
 mirrored volumes  
 adding DRL logs 366  
 adding sequential DRL logs 366  
 changing read policies for 371  
 configuring VxVM to create by default 356  
 creating 319  
 creating across controllers 318, 327

- mirrored volumes (*continued*)
  - creating across enclosures 327
  - creating across targets 316
  - defined 305
  - dirty region logging 59
  - DRL 59
  - FastResync 59
  - FR 59
  - logging 59
  - performance 546
  - removing DRL logs 367
  - removing sequential DRL logs 367
  - snapshots 65
- mirrored-concatenated volumes
  - converting to concatenated-mirror 383
  - creating 320
  - defined 44
- mirrored-stripe volumes
  - benefits of 44
  - converting to striped-mirror 383
  - creating 326
  - defined 305
  - performance 547
- mirroring
  - boot disk 134
  - defined 43
  - guidelines 605
  - root disk 134
- mirroring controllers 606
- mirroring plus striping 45
- mirrors
  - adding to volumes 355
  - creating snapshot 433
  - defined 36
  - removing from volumes 359
  - specifying number of 320
- mirvol attribute 414
- mirvol snapshot type 426
- monitor\_fabric tunable 569
- mrl
  - keyword 199
- Multi-Volume Support 447
- multipathing
  - disabling 172
  - displaying information about 175
  - enabling 174

## N

- names
  - changing for disk groups 248
  - defining for snapshot volumes 436
  - device 24, 82
  - disk 82
  - disk media 32, 82
  - plex 35
  - plex attribute 300
  - renaming disks 156
  - subdisk 33
  - subdisk attribute 287
  - VM disk 33
  - volume 35
- naming
  - DMP nodes 178
- naming scheme
  - changing for disks 107
  - changing for TPD enclosures 111
  - displaying for disks 109
- naming schemes
  - for disks 83
- ncachemirror attribute 406
- ndcomirror attribute 322, 324, 442
- ndcomirs attribute 361, 402
- NEEDSYNC volume state 340
- newvol attribute 412
- nmirror attribute 411–412
- NODAREC plex condition 293
- nodes
  - DMP 167
  - in clusters 490
  - maximum number in a cluster 504
  - requesting status of 515
  - shutdown in clusters 512
  - use of vxclust 506
  - use of vxclustadm to control CVM functionality 507
- NODEVICE plex condition 293
- nodg 222
- nomannual path attribute 197
- non-autotrespass mode 166
- non-layered volume conversion 383
- Non-Persistent FastResync 66
- nopreferred path attribute 197
- nopriv devices 130
- nopriv disk type 86
- nopriv disks
  - issues with enclosures 112



**O**

- objects
  - physical 24
  - virtual 30
- off-host processing 455, 504
- OFFLINE plex state 292
- online backups
  - implementing 457
- online invalid status 142
- online relayout
  - changing number of columns 379
  - changing region size 382
  - changing speed of 382
  - changing stripe unit size 379
  - combining with conversion 383
  - controlling progress of 381
  - defined 53
  - destination layouts 376
  - failure recovery 57
  - how it works 53
  - limitations 56
  - monitoring tasks for 381
  - pausing 381
  - performing 376
  - resuming 381
  - reversing direction of 382
  - specifying non-default 379
  - specifying plexes 380
  - specifying task tags for 380
  - temporary area 54
  - transformation characteristics 57
  - transformations and volume length 57
  - types of transformation 376
  - viewing status of 381
- online status 142
- OpenBoot PROMs (OPB) 137
- ordered allocation 316, 323, 330
- OS-based naming 83
- OTHER\_DISKS category 90
- overlapped seeks 606

**P**

- parity in RAID-5 47
- partial device discovery 88
- partition size
  - displaying the value of 200
  - specifying 202
- partitions
  - number 24–25

- partitions (*continued*)
  - s2 84, 87
  - s3 87
  - s4 87
  - slices 25
- path aging 568
- path failover in DMP 169
- pathgroups
  - creating 173
- paths
  - disabling for DMP 207
  - enabling for DMP 208
  - setting attributes of 197, 199
- performance
  - analyzing data 550
  - benefits of using VxVM 545
  - changing values of tunables 555
  - combining mirroring and striping 547
  - displaying tunable values 556
  - effect of read policies 547
  - examining ratio of reads to writes 553
  - hot spots identified by I/O traces 553
  - impact of number of disk group configuration
    - copies 555
  - improving for instant snapshot
    - synchronization 427
  - load balancing in DMP 170
  - mirrored volumes 546
  - monitoring 548
  - moving volumes to improve 551
  - obtaining statistics for disks 551
  - obtaining statistics for volumes 549
  - RAID-5 volumes 547
  - setting priorities 548
  - striped volumes 546
  - striping to improve 552
  - tracing volume operations 549
  - tuning large systems 554
  - tuning VxVM 554
  - using I/O statistics 550
- persistence
  - device naming option 109
- persistent device name database 110
- persistent device naming 110
- Persistent FastResync 66–68
- physical disks
  - adding to disk groups 227
  - clearing locks on 234
  - complete failure messages 472

physical disks *(continued)*

- determining failed 472
  - displaying information 142
  - displaying information about 142, 225
  - displaying spare 476
  - enabling 155
  - enabling after hot swap 155
  - excluding free space from hot-relocation use 478
  - failure handled by hot-relocation 469
  - initializing 105
  - installing 114
  - making available for hot-relocation 476
  - making free space available for hot-relocation use 479
  - marking as spare 476
  - moving between disk groups 228, 264
  - moving disk groups between systems 233
  - moving volumes from 373
  - partial failure messages 471
  - postponing replacement 148
  - releasing from disk groups 269
  - removing 145, 148
  - removing from A5x00 arrays 154
  - removing from disk groups 227
  - removing from pool of hot-relocation spares 478
  - removing with subdisks 147
  - replacing 148
  - replacing in A5x00 arrays 154
  - replacing removed 152
  - reserving for special purposes 157
  - spare 473
  - taking offline 156
  - unreserving 158
- physical objects 24
- ping-pong effect 171
- plex attribute 412
- plex conditions
- IOFAIL 293
  - NODAREC 293
  - NODEVICE 293
  - RECOVER 294
  - REMOVED 294
- plex kernel states
- DETACHED 294
  - DISABLED 294
  - ENABLED 294
- plex states
- ACTIVE 291
  - CLEAN 291

plex states *(continued)*

- DCOSNP 291
  - EMPTY 291
  - IOFAIL 291
  - LOG 291
  - OFFLINE 292
  - SNAPATT 292
  - SNAPDIS 292
  - SNAPDONE 292
  - SNAPTMP 292
  - STALE 292
  - TEMP 292
  - TEMPRM 293
  - TEMPRMSD 293
- plexes
- adding to snapshots 438
  - associating log subdisks with 285
  - associating subdisks with 283
  - associating with volumes 294
  - attaching to volumes 294
  - changing attributes 300
  - changing read policies for 371
  - comment attribute 300
  - complete failure messages 472
  - condition flags 293
  - converting to snapshot 435
  - copying 299
  - creating 289
  - creating striped 289
  - defined 34
  - detaching from volumes temporarily 296
  - disconnecting from volumes 295
  - displaying information about 289
  - dissociating from volumes 299
  - dissociating subdisks from 286
  - failure in hot-relocation 469
  - kernel states 294
  - limit on number per volume 548
  - maximum number of subdisks 561
  - maximum number per volume 35
  - mirrors 36
  - moving 298, 363, 443
  - name attribute 300
  - names 35
  - partial failure messages 471
  - putil attribute 300
  - putting online 296
  - reattaching 296

- plexes (*continued*)
  - recovering after correctable hardware failure 472
  - removing 299
  - removing from volumes 359
  - sparse 57, 284, 294, 298
  - specifying for online relayout 380
  - states 290
  - striped 40
  - taking offline 295, 350
  - tutil attribute 300
  - types 34
- polling interval for DMP restore 214
- ports
  - listing 94
- PowerPath
  - coexistence with DMP 91
- prefer read policy 371
- preferred plex
  - read policy 371
- preferred priority path attribute 198
- primary boot disk failure 135
- primary path 166, 177
- primary path attribute 198
- priority load balancing 203
- private disk groups
  - converting from shared 519
  - in clusters 492
- private network
  - in clusters 491
- private region
  - configuration database 85
  - defined 85
  - effect of large disk groups on 221
- PROMs
  - boot 137
- prtconf
  - displaying tunables 556
- public region 85
- putil
  - plex attribute 300
  - subdisk attribute 287

## Q

- queued I/Os
  - displaying statistics 194

## R

- RAID-0 40
- RAID-0+1 44
- RAID-1 43
- RAID-1+0 45
- RAID-5
  - adding logs 384
  - adding subdisks to plexes 284
  - guidelines 608
  - hot-relocation limitations 469
  - logs 51, 58
  - parity 47
  - removing logs 385
  - specifying number of logs 329
  - subdisk failure handled by hot-relocation 469
  - volumes 47
- RAID-5 volumes
  - adding DCOs to 363
  - adding logs 384
  - changing number of columns 379
  - changing stripe unit size 379
  - creating 329
  - defined 305
  - performance 547
  - removing logs 385
- raw device nodes
  - controlling access for volume sets 453
  - displaying access for volume sets 453
  - enabling access for volume sets 452
  - for volume sets 451
- read policies
  - changing 371
  - performance of 547
  - prefer 371
  - round 371
  - select 371
  - siteread 371, 527–528, 530
  - split 371
- read-only mode 494
- readonly mode 493
- RECOVER plex condition 294
- recovery
  - checkpoint interval 557
  - I/O delay 557
  - preventing on restarting volumes 351
- recovery accelerator 60
- recovery option values
  - configuring 213
- redo log configuration 61

- redundancy
    - of data on mirrors 305
    - of data on RAID-5 305
  - redundancy levels
    - displaying for a device 198
    - specifying for a device 199
  - redundant-loop access 29
  - region 85
  - regionsize attribute 361, 402, 404
  - reinitialization of disks 123
  - relayout
    - changing number of columns 379
    - changing region size 382
    - changing speed of 382
    - changing stripe unit size 379
    - combining with conversion 383
    - controlling progress of 381
    - limitations 56
    - monitoring tasks for 381
    - online 53
    - pausing 381
    - performing online 376
    - resuming 381
    - reversing direction of 382
    - specifying non-default 379
    - specifying plexes 380
    - specifying task tags for 380
    - storage 53
    - transformation characteristics 57
    - types of transformation 376
    - viewing status of 381
  - relocation
    - automatic 467
    - complete failure messages 472
    - limitations 469
    - partial failure messages 471
  - Remote Mirror feature
    - administering 525
  - remote mirrors
    - administering 525
  - REMOVED plex condition 294
  - removing disks 148
  - removing physical disks 145
  - replacing disks 148
  - replay logs and sequential DRL 60
  - REPLAY volume state 340
  - resilvering
    - databases 60
  - restoration of disk group configuration 276
  - restore policy
    - check\_all 214
    - check\_alternate 215
    - check\_disabled 215
    - check\_periodic 215
  - restored daemon 169
  - resyncfromoriginal snapback 399
  - resyncfromreplica snapback 399
  - resynchronization
    - checkpoint interval 557
    - I/O delay 557
    - of volumes 58
  - resynchronizing
    - databases 60
  - retry option values
    - configuring 213
  - root disk
    - defined 131
    - encapsulating 134
    - listing volumes on 137
    - mirroring 134
    - mirroring other file systems on 137
    - unencapsulating 141
  - root disk group 32, 221
  - root disks
    - booting alternate 135
  - root volume 132–133
  - rootability 131
    - removing 141
  - rootdg 32
  - round read policy 371
  - round-robin
    - load balancing 203
    - read policy 371
- S**
- s# 24–25, 83
  - s2 partition 84, 87
  - s3 partition 87
  - s4 partition 87
  - SAN storage
    - configuring volumes on 73
  - scandisks
    - vxdisk subcommand 87
  - secondary path 166
  - secondary path attribute 198
  - secondary path display 177
  - select read policy 371

- sequential DRL
  - defined 60
  - maximum number of dirty regions 562
- sequential DRL attribute 324
- serial split brain condition 526
  - correcting 255
  - in campus clusters 250
  - in disk groups 250
- setting
  - path redundancy levels 199
- shared disk groups
  - activating 520
  - activation modes 493–494
  - converting to private 519
  - creating 517
  - importing 518
  - in clusters 492
  - limitations of 500
  - listing 516
- shared disks
  - configuring 610
- shared-read mode 494
- shared-write mode 494
- sharedread mode 493
- sharedwrite mode 493
- simple disk format 86
- simple disk type 86
- simple disks
  - issues with enclosures 112
- single active path policy 203
- Site Awareness license 532
- site consistency
  - configuring 533
  - defined 526
- site failure
  - simulating 534
- site failures
  - host failures 541
  - loss of connectivity 541
  - recovery from 534, 542
  - scenarios and recovery procedures 540
  - storage failures 542
- site-based allocation
  - configuring for disk groups 532
  - defined 526
- site-based consistency
  - configuring on existing disk groups 531
- siteconsistent attribute 533
- siteread read policy 371, 527–528, 530
- sites
  - reattaching 534
- size units 280
- slave nodes
  - defined 491
- sliced disk format 86
- sliced disk type 86
- slices
  - number 24
  - partitions 25
  - s2 84, 87
  - s3 87
  - s4 87
- SmartMove feature
  - setting up 311
- SmartSync 60
  - disabling on shared disk groups 561
  - enabling on shared disk groups 561
- snap objects 71
- snap volume naming 399
- snapabort 389
- SNAPATT plex state 292
- snapback
  - defined 389
  - merging snapshot volumes 437
  - resyncfromoriginal 399
  - resyncfromreplica 399, 437
- snapclear
  - creating independent volumes 439
- SNAPDIS plex state 292
- SNAPDONE plex state 292
- snapmir snapshot type 426
- snapshot hierarchies
  - creating 419
  - splitting 424
- snapshot mirrors
  - adding to volumes 418
  - removing from volumes 419
- snapshots
  - adding mirrors to volumes 418
  - adding plexes to 438
  - and FastResync 65
  - backing up multiple volumes 415, 436
  - backing up volumes online using 400
  - cascaded 395
  - comparison of features 63
  - converting plexes to 435
  - creating a hierarchy of 419
  - creating backups using third-mirror 431

snapshots (*continued*)

- creating for volume sets 416
- creating full-sized instant 408
- creating independent volumes 439
- creating instant 400
- creating linked break-off 413
- creating snapshots of 396
- creating space-optimized instant 406
- creating third-mirror break-off 410
- creating volumes for use as full-sized instant 405
- defining names for 436
- displaying information about 439
- displaying information about instant 424
- dissociating instant 423
- emulation of third-mirror 393
- finding out those configured on a cache 430
- full-sized instant 64, 390
- hierarchy of 395
- improving performance of synchronization 427
- linked break-off 394
- listing for a cache 428
- merging with original volumes 437
- of volumes 62
- on multiple volumes 399
- reattaching instant 420
- reattaching linked third-mirror 421
- refreshing instant 420
- removing 435
- removing instant 423
- removing linked snapshots from volumes 419
- removing mirrors from volumes 419
- restoring from instant 422
- resynchronization on snapback 399
- resynchronizing volumes from 437
- space-optimized instant 392
- synchronizing instant 426
- third-mirror 63
- use of copy-on-write mechanism 391

snapstart 389  
 SNAPTMP plex state 292  
 snapvol attribute 408, 414  
 snapwait 411, 414  
 source attribute 408, 414  
 space-optimized instant snapshots 392
 

- creating 406

 spaceopt snapshot type 426  
 spanned volumes 38  
 spanning 38

## spare disks

- displaying 476
- marking disks as 476
- used for hot-relocation 473

sparse plexes 57, 284, 294, 298  
 specifying
 

- redundancy levels 199

 split read policy 371  
 STALE plex state 292  
 standby path attribute 198  
 states
 

- for plexes 290
- of link objects 394
- volume 340

 statistics gathering 169  
 storage
 

- ordered allocation of 316, 323, 330

 storage accounts 73  
 storage attributes and volume layout 313  
 storage cache
 

- used by space-optimized instant snapshots 392

 storage failures 542  
 storage groups 73  
 storage processor 166  
 storage relayout 53  
 stripe columns 40  
 stripe unit size recommendations 607  
 stripe units
 

- changing size 379
- defined 40

 stripe-mirror-col-split-trigger-pt 327  
 striped plexes
 

- adding subdisks 284
- defined 40

 striped volumes
 

- changing number of columns 379
- changing stripe unit size 379
- creating 325
- defined 304
- failure of 40
- performance 546
- specifying non-default number of columns 326
- specifying non-default stripe unit size 326

 striped-mirror volumes
 

- benefits of 45
- converting to mirrored-stripe 383
- creating 327
- defined 305
- mirroring columns 327

- striped-mirror volumes (*continued*)
    - mirroring subdisks 327
    - performance 547
    - trigger point for mirroring 327
  - striping 40
  - striping guidelines 607
  - striping plus mirroring 44
  - subdisk names 33
  - subdisks
    - associating log subdisks 285
    - associating with plexes 283
    - associating with RAID-5 plexes 284
    - associating with striped plexes 284
    - blocks 33
    - changing attributes 287
    - comment attribute 288
    - complete failure messages 472
    - copying contents of 282
    - creating 280
    - defined 33
    - determining failed 472
    - displaying information about 281
    - dissociating from plexes 286
    - dividing 282
    - DRL log 59
    - hot-relocation 73, 467, 474
    - hot-relocation messages 480
    - joining 283
    - len attribute 288
    - listing original disks after hot-relocation 485
    - maximum number per plex 561
    - mirroring in striped-mirror volumes 327
    - moving after hot-relocation 480
    - moving contents of 282
    - name attribute 287
    - partial failure messages 471
    - physical disk placement 605
    - putil attribute 287
    - RAID-5 failure of 469
    - RAID-5 plex, configuring 608
    - removing from VxVM 286–287
    - restrictions on moving 282
    - specifying different offsets for unrelocation 484
    - splitting 282
    - tutil attribute 288
    - unrelocating after hot-relocation 480
    - unrelocating to different disks 484
    - unrelocating using vxassist 482
    - unrelocating using vxdiskadm 481
  - subdisks (*continued*)
    - unrelocating using vxunreloc 483
  - SYNC volume state 341
  - synchronization
    - controlling for instant snapshots 426
    - improving performance of 427
  - syncing attribute 400, 426
  - syncpause 427
  - syncresume 427
  - syncstart 427
  - syncstop 427
  - syncwait 427
- ## T
- t# 24, 83
  - tags
    - for tasks 342
    - listing for disks 241
    - removing from disks 242
    - removing from volumes 369
    - renaming 369
    - setting on disks 241
    - setting on volumes 331, 369
    - specifying for online relay layout tasks 380
    - specifying for tasks 342
  - target IDs
    - number 24
    - specifying to vxassist 313
  - target mirroring 316, 327
  - targets
    - listing 95
  - task monitor in VxVM 342
  - tasks
    - aborting 343
    - changing state of 343–344
    - identifiers 342
    - listing 344
    - managing 343
    - modifying parameters of 344
    - monitoring 344
    - monitoring online relay layout 381
    - pausing 344
    - resuming 344
    - specifying tags 342
    - specifying tags on online relay layout operation 380
    - tags 342
  - TEMP plex state 292
  - temporary area used by online relay layout 54
  - TEMPRM plex state 293

- TEMPRMSD plex state 293
- third-mirror
  - snapshots 63
- third-mirror break-off snapshots
  - creating 410
- third-mirror snapshots 393
- third-party driver (TPD) 91
- throttling 169
- TPD
  - displaying path information 187
  - support for coexistence 91
- tpdmode attribute 111
- trigger point in striped-mirror volumes 327
- tunables
  - changing values of 555
  - displaying using prtconf 556
  - dmp\_cache\_open 566
  - dmp\_daemon\_count 566
  - dmp\_delayq\_interval 567
  - dmp\_failed\_io\_threshold 567
  - dmp\_fast\_recovery 567
  - dmp\_health\_time 568
  - dmp\_log\_level 568
  - dmp\_path\_age 570
  - dmp\_pathswitch\_blks\_shift 570
  - dmp\_probe\_idle\_lun 571
  - dmp\_queue\_depth 571
  - dmp\_retry\_count 572
  - dmp\_scsi\_timeout 573
  - dmp\_stat\_interval 573
  - monitor\_fabric 569
  - vol\_checkpoint\_default 557
  - vol\_default\_iodelay 557
  - vol\_fmr\_logsz 66, 558
  - vol\_kmsg\_resend\_period 559
  - vol\_kmsg\_resend\_period\_usec 559
  - vol\_kmsg\_send\_period 559
  - vol\_kmsg\_send\_period\_usec 559
  - vol\_max\_vol 559
  - vol\_maxio 560
  - vol\_maxioctl 560
  - vol\_maxparallelio 560
  - vol\_maxspecialio 561
  - vol\_subdisk\_num 561
  - volcvm\_smartsync 561
  - voldr\_max\_drtregs 562
  - voldr\_max\_seq\_dirty 60, 562
  - voldr\_min\_regionsz 562
  - voliomem\_chunk\_size 562

- tunables (*continued*)
  - voliomem\_maxpool\_sz 563
  - voliot\_errbuf\_dflt 563
  - voliot\_iobuf\_default 564
  - voliot\_iobuf\_limit 564
  - voliot\_iobuf\_max 564
  - voliot\_max\_open 564
  - volpagemod\_max\_memsz 565
  - volraid\_minpool\_size 565
  - volraid\_rsrtransmax 566
- tutil
  - plex attribute 300
  - subdisk attribute 288

## U

- UDID flag 239
- udid\_mismatch flag 239
- UFS file system resizing 352
- unencapsulating the root disk 141
- units of size 280
- Upgrading
  - ISP disk group 277
- use\_all\_paths attribute 204
- use\_avid
  - vxddladm option 109
- user-specified device names 178
- usesfsmartmove parameter 311

## V

- V-5-1-2536 353
- V-5-1-2829 271
- V-5-1-552 227
- V-5-1-569 502
- V-5-1-587 234
- V-5-2-3091 261
- V-5-2-369 228
- V-5-2-4292 261
- version 0
  - of DCOs 67
- version 20
  - of DCOs 67
- versioning
  - of DCOs 67
- versions
  - disk group 270
  - displaying for disk group 274
  - upgrading 270
- virtual objects 30



## VM disks

- defined 32
  - determining if shared 516
  - displaying spare 476
  - excluding free space from hot-relocation use 478
  - initializing 105
  - making free space available for hot-relocation use 479
  - marking as spare 476
  - mirroring volumes on 356
  - moving volumes from 373
  - names 33
  - postponing replacement 148
  - removing from pool of hot-relocation spares 478
  - renaming 156
- vol## 35
- vol##-## 35
- vol\_checkpoint\_default tunable 557
- vol\_default\_iodelay tunable 557
- vol\_fmr\_logsz tunable 66, 558
- vol\_kmsg\_resend\_period tunable 559
- vol\_kmsg\_resend\_period\_usecs tunable 559
- vol\_kmsg\_send\_period tunable 559
- vol\_kmsg\_send\_period\_usecs tunable 559
- vol\_max\_vol tunable 559
- vol\_maxioctl tunable 560
- vol\_maxparallelio tunable 560
- vol\_maxspecialio tunable 561
- vol\_subdisk\_num tunable 561
- volatile devices 124
- volbrk snapshot type 426
- volcvm\_smartsync tunable 561
- voldrl\_max\_drtregs tunable 562
- voldrl\_max\_seq\_dirty tunable 60, 562
- voldrl\_min\_regionsz tunable 562
- voliomem\_chunk\_size tunable 562
- voliomem\_maxpool\_sz tunable 563
- voliot\_errbuf\_dflt tunable 563
- voliot\_iobuf\_default tunable 564
- voliot\_iobuf\_limit tunable 564
- voliot\_iobuf\_max tunable 564
- voliot\_max\_open tunable 564
- volpagemod\_max\_memsz tunable 565
- volraid\_minpool\_size tunable 565
- volraid\_rsrtransmax tunable 566
- volume kernel states
- DETACHED 341
  - DISABLED 341

volume kernel states *(continued)*

- ENABLED 341
- volume length, RAID-5 guidelines 608
- volume resynchronization 58
- volume sets
- adding volumes to 448
  - administering 447
  - controlling access to raw device nodes 453
  - creating 448
  - creating instant snapshots of 416
  - displaying access to raw device nodes 453
  - enabling access to raw device nodes 452
  - listing details of 449
  - raw device nodes 451
  - removing volumes from 449
  - starting 450
  - stopping 450
- volume states
- ACTIVE 340
  - CLEAN 340
  - EMPTY 340
  - INVALID 340
  - NEEDSYNC 340
  - REPLAY 340
  - SYNC 341
- volumes
- accessing device files 335, 609
  - adding DRL logs 366
  - adding logs and maps to 360
  - adding mirrors 355
  - adding RAID-5 logs 384
  - adding sequential DRL logs 366
  - adding snapshot mirrors to 418
  - adding subdisks to plexes of 284
  - adding to volume sets 448
  - adding version 0 DCOs to 440
  - adding version 20 DCOs to 361
  - advanced approach to creating 307
  - assisted approach to creating 307
  - associating plexes with 294
  - attaching plexes to 294
  - backing up 388
  - backing up online using snapshots 400
  - block device files 335, 609
  - boot-time restrictions 133
  - booting root 132–133
  - changing layout online 376
  - changing number of columns 379
  - changing read policies for mirrored 371

volumes *(continued)*

- changing stripe unit size 379
- character device files 335, 609
- checking if FastResync is enabled 375
- combining mirroring and striping for performance 547
- combining online relay layout and conversion 383
- concatenated 38, 304
- concatenated-mirror 46, 305
- configuring exclusive open by cluster node 521
- configuring on SAN storage 73
- configuring site consistency on 537
- converting between layered and non-layered 383
- converting concatenated-mirror to mirrored-concatenated 383
- converting mirrored-concatenated to concatenated-mirror 383
- converting mirrored-stripe to striped-mirror 383
- converting striped-mirror to mirrored-stripe 383
- creating 307
- creating concatenated-mirror 320
- creating for use as full-sized instant snapshots 405
- creating from snapshots 439
- creating mirrored 319
- creating mirrored-concatenated 320
- creating mirrored-stripe 326
- creating RAID-5 329
- creating snapshots 434
- creating striped 325
- creating striped-mirror 327
- creating using vxmake 331
- creating using vxmake description file 333
- creating with version 0 DCOs attached 321
- creating with version 20 DCOs attached 324
- defined 35
- detaching plexes from temporarily 296
- disabling FastResync 375
- disconnecting plexes 295
- displaying information 338
- displaying information about snapshots 439
- dissociating plexes from 299
- dissociating version 0 DCOs from 444
- DRL 606
- effect of growing on FastResync maps 71
- enabling FastResync on 374
- enabling FastResync on new 322

volumes *(continued)*

- excluding storage from use by vxassist 313
- finding maximum size of 311
- finding out maximum possible growth of 351
- flagged as dirty 58
- initializing contents to zero 335
- initializing using vxassist 334
- initializing using vxvol 335
- kernel states 341
- layered 45, 51, 305
- limit on number of plexes 35
- limitations 35
- listing on boot (root) disk 137
- making immediately available for use 334
- maximum number of 559
- maximum number of data plexes 548
- merging snapshots 437
- mirrored 43, 305
- mirrored-concatenated 44
- mirrored-stripe 44, 305
- mirroring across controllers 318, 327
- mirroring across targets 316, 327
- mirroring all 356
- mirroring on disks 356
- moving from VM disks 373
- moving to improve performance 551
- names 35
- naming snap 399
- obtaining performance statistics 549
- performance of mirrored 546
- performance of RAID-5 547
- performance of striped 546
- performing online relay layout 376
- placing in maintenance mode 350
- preparing for DRL and instant snapshot operations 361
- preventing recovery on restarting 351
- RAID-0 40
- RAID-0+1 44
- RAID-1 43
- RAID-1+0 45
- RAID-10 45
- RAID-5 47, 305
- raw device files 335, 609
- reattaching plexes 296
- reattaching version 0 DCOs to 444
- reconfiguration in clusters 508
- recovering after correctable hardware failure 472

**volumes** (*continued*)

- removing 372
- removing DRL logs 367
- removing from /etc/vfstab 372
- removing linked snapshots from 419
- removing mirrors from 359
- removing plexes from 359
- removing RAID-5 logs 385
- removing sequential DRL logs 367
- removing snapshot mirrors from 419
- removing support for DRL and instant snapshots 365
- removing version 0 DCOs from 444
- resizing 351
- resizing using vxassist 353
- resizing using vxresize 352
- resizing using vxvol 355
- restarting moved 265, 267–268
- restoring from instant snapshots 422
- resynchronizing from snapshots 437
- snapshots 62
- spanned 38
- specifying default layout 312
- specifying non-default number of columns 326
- specifying non-default relayout 379
- specifying non-default stripe unit size 326
- specifying storage for version 0 DCO plexes 443
- specifying storage for version 20 DCO plexes 362
- specifying use of storage to vxassist 313
- starting 350
- starting using vxassist 334
- starting using vxvol 335
- states 340
- stopping 349
- stopping activity on 372
- striped 40, 304
- striped-mirror 45, 305
- striping to improve performance 552
- taking multiple snapshots 399
- tracing operations 549
- trigger point for mirroring in striped-mirror 327
- types of layout 304
- upgrading to use new features 367
- using logs and maps with 306
- zeroing out contents of 334

**vxassist**

- adding a log subdisk 286
- adding a RAID-5 log 384

**vxassist** (*continued*)

- adding DCOs to volumes 442
- adding DRL logs 366
- adding mirrors to volumes 295, 355
- adding sequential DRL logs 366
- advantages of using 308
- command usage 309
- configuring exclusive access to a volume 521
- configuring site consistency on volumes 537
- converting between layered and non-layered volumes 383
- creating cache volumes 403
- creating concatenated-mirror volumes 320
- creating mirrored volumes 320
- creating mirrored-concatenated volumes 320
- creating mirrored-stripe volumes 326
- creating RAID-5 volumes 329
- creating snapshots 431
- creating striped volumes 325
- creating striped-mirror volumes 327
- creating volumes 308
- creating volumes for use as full-sized instant snapshots 405
- creating volumes with DRL enabled 324
- creating volumes with version 0 DCOs attached 322
- creating volumes with version 20 DCOs attached 324
- defaults file 309
- defining layout on specified storage 313
- discovering maximum volume size 311
- displaying information about snapshots 439
- dissociating snapshots from volumes 439
- excluding storage from use 313
- finding out how much volumes can grow 351
- listing tags set on volumes 331, 370
- merging snapshots with volumes 437
- mirroring across controllers 318, 327
- mirroring across enclosures 327
- mirroring across targets 316, 318
- mirroring file systems on root disk 137
- moving DCO log plexes 363
- moving DCO plexes 443
- moving subdisks after hot-relocation 482
- moving volumes 552
- relaying out volumes online 376
- removing DCOs from volumes 369
- removing DRL logs 367
- removing mirrors 359

**vxassist** (*continued*)

- removing plexes 359
- removing RAID-5 logs 385
- removing tags from volumes 369
- removing version 0 DCOs from volumes 444
- removing volumes 372
- replacing tags set on volumes 369
- reserving disks 158
- resizing volumes 353
- resynchronizing volumes from snapshots 437
- setting default values 309
- setting tags on volumes 331, 369–370
- snapabort 389
- snapback 389
- snapshot 389
- snapstart 389
- specifying number of mirrors 320
- specifying number of RAID-5 logs 329
- specifying ordered allocation of storage 316
- specifying plexes for online relayout 380
- specifying storage attributes 313
- specifying storage for version 0 DCO plexes 443
- specifying tags for online relayout tasks 380
- taking snapshots of multiple volumes 436
- unrelocating subdisks after hot-relocation 482

**vxcache**

- listing snapshots in a cache 428
- resizing caches 430
- starting cache objects 404
- stopping a cache 431
- tuning cache autogrow 429

**vxcached**

- tuning 428

**vxclust** 506**vxclustadm** 507**vxconfigd**

- managing with vxdtl 275
- monitoring configuration changes 276
- operation in clusters 510

**vxrestore**

- handling simple/nopriv disk failures 112

**vxdc**

- dissociating version 0 DCOs from volumes 444
- reattaching version 0 DCOs to volumes 444
- removing version 0 DCOs from volumes 444

**vxdtl**

- checking cluster protocol version 522
- enabling disks after hot swap 155
- managing vxconfigd 275

**vxdtl** (*continued*)

- setting a site tag 532, 535
- setting default disk group 224
- upgrading cluster protocol version 523
- usage in clusters 515

**vxdtl enable**

- invoking device discovery 91

**vxddladm**

- adding disks to DISKS category 101
- adding foreign devices 104
- changing naming scheme 109
- displaying the disk-naming scheme 109
- excluding support for disk arrays 99
- listing all devices 93
- listing configured devices 96
- listing configured targets 95–96
- listing excluded disk arrays 99, 101
- listing ports on a Host Bus Adapter 95
- listing supported disk arrays 98
- listing supported disks in DISKS category 99
- listing supported HBAs 94
- re-including support for disk arrays 99
- removing disks from DISKS category 92, 103–104
- setting iSCSI parameters 97

**vxdg**

- changing activation mode on shared disk groups 520
- clearing locks on disks 235
- configuring site consistency for a disk group 533
- configuring site-based allocation for a disk group 532
- controlling CDS compatibility of new disk groups 226
- converting shared disk groups to private 519
- correcting serial split brain condition 256
- creating disk groups 226
- creating disk groups with old version number 275
- creating shared disk groups 517
- deporting disk groups 230
- destroying disk groups 269
- disabling a disk group 269
- displaying boot disk group 223
- displaying default disk group 223
- displaying disk group version 274
- displaying free space in disk groups 225
- displaying information about disk groups 224
- forcing import of disk groups 235

*vx dg (continued)*

- importing a disk group containing cloned disks 240
- importing cloned disks 242
- importing disk groups 231
- importing shared disk groups 518
- joining disk groups 267
- listing disks with configuration database copies 242
- listing objects affected by move 261
- listing shared disk groups 516
- listing spare disks 476
- moving disk groups between systems 233
- moving disks between disk groups 228
- moving objects between disk groups 263
- obtaining copy size of configuration database 221
- placing a configuration database on cloned disks 241
- reattaching a site 534
- recovering destroyed disk groups 270
- removing disks from disk groups 227
- renaming disk groups 248
- setting a site name 537, 540
- setting base minor number 237
- setting disk connectivity policy in a cluster 520
- setting disk group policies 500
- setting failure policy in a cluster 521
- setting maximum number of devices 238
- simulating site failure 534
- splitting disk groups 266
- upgrading disk group version 274

*vx disk*

- clearing locks on disks 234
- defaults file 87, 115
- determining if disks are shared 516
- discovering disk access names 114
- displaying information about disks 225
- displaying multipathing information 176
- listing disks 142
- listing spare disks 476
- listing tags on disks 241
- notifying dynamic LUN expansion 144
- placing a configuration database on a cloned disk 241
- removing tags from disks 242
- scanning disk devices 87
- setting a site name 536
- setting tags on disks 241

*vx disk (continued)*

- updating the disk identifier 240
- vx disk scandisks*
- rescanning devices 88
  - scanning devices 88
- vx diskadd*
- adding disks to disk groups 227
  - creating disk groups 226
  - placing disks under VxVM control 124
- vx diskadm*
- Add or initialize one or more disks 115, 226
  - adding disks 115
  - adding disks to disk groups 227
  - Change/display the default disk layout 115
  - changing the disk-naming scheme 107
  - creating disk groups 226
  - deporting disk groups 229
  - Disable (offline) a disk device 156
  - Enable (online) a disk device 155
  - Enable access to (import) a disk group 230
  - Encapsulate one or more disks 127
  - Exclude a disk from hot-relocation use 479
  - excluding free space on disks from hot-relocation use 479
  - importing disk groups 230
  - initializing disks 115
  - List disk information 143
  - listing spare disks 476
  - Make a disk available for hot-relocation use 480
  - making free space on disks available for hot-relocation use 480
  - Mark a disk as a spare for a disk group 477
  - marking disks as spare 477
  - Mirror volumes on a disk 357
  - mirroring disks 132
  - mirroring root disks 135
  - mirroring volumes 357
  - Move volumes from a disk 373
  - moving disk groups between systems 236
  - moving disks between disk groups 229
  - moving subdisks after hot-relocation 481
  - moving subdisks from disks 228
  - moving volumes from VM disks 373
  - Remove a disk 145, 228
  - Remove a disk for replacement 149
  - Remove access to (deport) a disk group 229
  - removing disks from pool of hot-relocation spares 478
  - Replace a failed or removed disk 152

**vxdiskadm** (*continued*)

- Turn off the spare flag on a disk 478
- Unrelocate subdisks back to a disk 481
- unrelocating subdisks after hot-relocation 481

**vxdiskconfig**

- purpose of 87

**vxdiskunsetup**

- removing disks from VxVM control 148, 228

**vxdkmpadm**

- changing TPD naming scheme 111
- configuring an APM 217
- configuring I/O throttling 211
- configuring response to I/O errors 210, 213
- disabling controllers in DMP 174
- disabling I/O in DMP 207
- discovering disk access names 114
- displaying APM information 217
- displaying DMP database information 175
- displaying DMP node for a path 180, 182
- displaying DMP node for an enclosure 180–181
- displaying I/O error recovery settings 213
- displaying I/O policy 200
- displaying I/O throttling settings 213
- displaying information about controllers 185
- displaying information about enclosures 186
- displaying partition size 200
- displaying paths controlled by DMP node 183
- displaying status of DMP error handling thread 216
- displaying status of DMP restoration thread 216
- displaying TPD information 187
- enabling I/O in DMP 208
- gathering I/O statistics 191
- listing information about array ports 187
- removing an APM 217
- renaming enclosures 209
- setting I/O policy 202–203
- setting path attributes 198
- setting restore polling interval 214
- specifying DMP path restoration policy 214
- stopping DMP restore daemon 216

**vxdkmpadm list**

- displaying DMP nodes 181

**vxedit**

- changing plex attributes 300
- changing subdisk attributes 287–288
- configuring number of configuration copies for a disk group 555

**vxedit** (*continued*)

- excluding free space on disks from hot-relocation use 478
- making free space on disks available for hot-relocation use 479
- marking disks as spare 477
- removing a cache 431
- removing disks from pool of hot-relocation spares 478
- removing instant snapshots 423
- removing plexes 300
- removing snapshots from a cache 430
- removing subdisks from VxVM 287
- removing volumes 372
- renaming disks 157
- reserving disks 158

**vxencap**

- defaults file 115

**VxFS file system resizing** 352**vxiod I/O kernel threads** 23**vxmake**

- associating plexes with volumes 295
- associating subdisks with new plexes 283
- creating cache objects 404
- creating plexes 289, 356
- creating striped plexes 289
- creating subdisks 280
- creating volumes 331
- using description file with 333

**vxmend**

- re-enabling plexes 297
- taking plexes offline 295, 350

**vxmirror**

- configuring VxVM default behavior 356
- mirroring root disks 135
- mirroring volumes 356

**vxnotify**

- monitoring configuration changes 276

**vxplex**

- adding RAID-5 logs 384
- attaching plexes to volumes 294, 356
- converting plexes to snapshots 435
- copying plexes 299
- detaching plexes temporarily 296
- dissociating and removing plexes 299
- dissociating plexes from volumes 300
- moving plexes 298
- reattaching plexes 296
- removing mirrors 359

**vxplex** (*continued*)

- removing mirrors of root disk volumes 142
- removing plexes 359
- removing RAID-5 logs 385

**vxprint**

- checking if FastResync is enabled 375
- determining if DRL is enabled 364
- displaying DCO information 362, 443
- displaying plex information 289
- displaying snapshots configured on a cache 430
- displaying subdisk information 281
- displaying volume information 338
- enclosure-based disk names 114
- identifying RAID-5 log plexes 385
- listing spare disks 476
- listing volumes on boot disks 137
- used with enclosure-based disk names 114
- verifying if volumes are prepared for instant snapshots 402
- viewing base minor number 236

**vxrecover**

- preventing recovery 351
- recovering plexes 472
- restarting moved volumes 265, 267–268
- restarting volumes 351

**vxrelayout**

- resuming online relayout 381
- reversing direction of online relayout 382
- viewing status of online relayout 381

**vxrelocd**

- hot-relocation daemon 468
- modifying behavior of 486
- notifying users other than root 487
- operation of 469
- preventing from running 487
- reducing performance impact of recovery 487

**vxresize**

- growing volumes and file systems 352
- limitations 352
- shrinking volumes and file systems 352

**vxsd**

- adding log subdisks 286
- adding subdisks to RAID-5 plexes 284
- adding subdisks to striped plexes 284
- associating subdisks with existing plexes 284
- dissociating subdisks 286
- filling in sparse plexes 284
- joining subdisks 283
- moving subdisk contents 282

**vxsd** (*continued*)

- removing subdisks from VxVM 286
- splitting subdisks 282

**vxsnap**

- adding snapshot mirrors to volumes 418
- administering instant snapshots 391
- backing up multiple volumes 415
- controlling instant snapshot synchronization 427
- creating a cascaded snapshot hierarchy 419
- creating full-sized instant snapshots 408, 414
- creating linked break-off snapshot volumes 414
- creating space-optimized instant snapshots 406
- displaying information about instant snapshots 424–425
- dissociating instant snapshots 423
- preparing volumes for DRL and instant snapshots operations 361
- preparing volumes for instant snapshots 402
- reattaching instant snapshots 420
- reattaching linked third-mirror snapshots 421
- refreshing instant snapshots 420
- removing a snapshot mirror from a volume 419
- removing support for DRL and instant snapshots 365
- restore 391
- restoring volumes 422
- splitting snapshot hierarchies 424

**vxspcshow**

- discovering device names 75

**vxsplitlines**

- diagnosing serial split brain condition 255

**vxstat**

- determining which disks have failed 472
- obtaining disk performance statistics 551
- obtaining volume performance statistics 549
- usage with clusters 523
- zeroing counters 551

**vxtask**

- aborting tasks 345
- listing tasks 344
- monitoring online relayout 381
- monitoring tasks 345
- pausing online relayout 381
- resuming online relayout 381
- resuming tasks 345

**vxtrace**

- tracing volume operations 549

**vxtune**

- setting `volpagemod_max_memsz` 565

**vxunreloc**

- listing original disks of hot-relocated subdisks 485
- moving subdisks after hot-relocation 483
- restarting after errors 485
- specifying different offsets for unrelocated subdisks 484
- unrelocating subdisks after hot-relocation 483
- unrelocating subdisks to different disks 484

**vxunroot**

- removing rootability 142
- unencapsulating the root disk 142

**VxVM**

- benefits to performance 545
- cluster functionality (CVM) 503
- configuration daemon 275
- configuring to create mirrored volumes 356
- dependency on operating system 22
- disk discovery 87, 89
- granularity of memory allocation by 562
- limitations of shared disk groups 500
- maximum number of data plexes per volume 548
- maximum number of subdisks per plex 561
- maximum number of volumes 559
- maximum size of memory pool 563
- minimum size of memory pool 565
- objects in 30
- operation in clusters 490
- performance tuning 554
- removing disks from 228
- removing disks from control of 147
- rootability 131
- shared objects in cluster 493
- size units 280
- task monitor 342
- types of volume layout 304
- upgrading 270
- upgrading disk group version 274

- `VXVM_DEFAULTDG` environment variable 222

**vxvol**

- configuring exclusive access to a volume 521
- configuring site consistency on volumes 537
- disabling DRL 365
- disabling `FastResync` 375
- enabling `FastResync` 374
- initializing volumes 335

**vxvol** (*continued*)

- putting volumes in maintenance mode 350
- re-enabling DRL 365
- resizing logs 355
- resizing volumes 355
- restarting moved volumes 265, 267–268
- setting read policy 371
- starting volumes 335, 350
- stopping volumes 349, 372
- zeroing out volumes 335

**vxvset**

- adding volumes to volume sets 448
- controlling access to raw device nodes 453
- creating volume sets 448
- creating volume sets with raw device access 452
- listing details of volume sets 449
- removing volumes from volume sets 449
- starting volume sets 450
- stopping volume sets 450

**W****warning messages**

- Specified region-size is larger than the limit on the system 401

- worldwide name identifiers 83, 108

- WWN identifiers 83, 108

**Z****zero**

- setting volume contents to 334