

**Sun StorageTek™ 5320 NAS
Appliance and Gateway System Getting Started
Guide**

Installing and Configuring the System



Part No. 819-4283-12
April 2011, Revision A

Copyright 2007 Sun Microsystems, Inc., 4150 Network Circle, Santa Clara, California 95054, U.S.A. All rights reserved.

Sun Microsystems, Inc. has intellectual property rights relating to technology that is described in this document. In particular, and without limitation, these intellectual property rights may include one or more of the U.S. patents listed at <http://www.sun.com/patents> and one or more additional patents or pending patent applications in the U.S. and in other countries.

This document and the product to which it pertains are distributed under licenses restricting their use, copying, distribution, and decompilation. No part of the product or of this document may be reproduced in any form by any means without prior written authorization of Sun and its licensors, if any.

Third-party software, including font technology, is copyrighted and licensed from Sun suppliers.

Parts of the product may be derived from Berkeley BSD systems, licensed from the University of California. UNIX is a registered trademark in the U.S. and in other countries, exclusively licensed through X/Open Company, Ltd.

Sun, Sun Microsystems, the Sun logo, Java, AnswerBook2, docs.sun.com, Sun StorageTek, FlexLine, Sun Fire, and Solaris are trademarks or registered trademarks of Sun Microsystems, Inc. in the U.S. and in other countries.

All SPARC trademarks are used under license and are trademarks or registered trademarks of SPARC International, Inc. in the U.S. and in other countries. Products bearing SPARC trademarks are based upon an architecture developed by Sun Microsystems, Inc. Netscape Navigator and Mozilla are trademark or registered trademarks of Netscape Communications Corporation in the United States and other countries.

The OPEN LOOK and Sun™ Graphical User Interface was developed by Sun Microsystems, Inc. for its users and licensees. Sun acknowledges the pioneering efforts of Xerox in researching and developing the concept of visual or graphical user interfaces for the computer industry. Sun holds a non-exclusive license from Xerox to the Xerox Graphical User Interface, which license also covers Sun's licensees who implement OPEN LOOK GUIs and otherwise comply with Sun's written license agreements.

U.S. Government Rights—Commercial use. Government users are subject to the Sun Microsystems, Inc. standard license agreement and applicable provisions of the FAR and its supplements.

DOCUMENTATION IS PROVIDED "AS IS" AND ALL EXPRESS OR IMPLIED CONDITIONS, REPRESENTATIONS AND WARRANTIES, INCLUDING ANY IMPLIED WARRANTY OF MERCHANTABILITY, FITNESS FOR A PARTICULAR PURPOSE OR NON-INFRINGEMENT, ARE DISCLAIMED, EXCEPT TO THE EXTENT THAT SUCH DISCLAIMERS ARE HELD TO BE LEGALLY INVALID.

Copyright 2007 Sun Microsystems, Inc., 4150 Network Circle, Santa Clara, Californie 95054, États-Unis. Tous droits réservés.

Sun Microsystems, Inc. possède les droits de propriété intellectuels relatifs à la technologie décrite dans ce document. En particulier, et sans limitation, ces droits de propriété intellectuels peuvent inclure un ou plusieurs des brevets américains listés sur le site <http://www.sun.com/patents>, un ou les plusieurs brevets supplémentaires ainsi que les demandes de brevet en attente aux États-Unis et dans d'autres pays.

Ce document et le produit auquel il se rapporte sont protégés par un copyright et distribués sous licences, celles-ci en restreignent l'utilisation, la copie, la distribution, et la décompilation. Aucune partie de ce produit ou document ne peut être reproduite sous aucune forme, par quelque moyen que ce soit, sans l'autorisation préalable et écrite de Sun et de ses bailleurs de licence, s'il y en a.

Tout logiciel tiers, sa technologie relative aux polices de caractères, comprise, est protégé par un copyright et licencié par des fournisseurs de Sun.

Des parties de ce produit peuvent dériver des systèmes Berkeley BSD licenciés par l'Université de Californie. UNIX est une marque déposée aux États-Unis et dans d'autres pays, licenciée exclusivement par X/Open Company, Ltd.

Sun, Sun Microsystems, le logo Sun, Java, AnswerBook2, docs.sun.com, Sun StorageTek, et Solaris sont des marques de fabrique ou des marques déposées de Sun Microsystems, Inc. aux États-Unis et dans d'autres pays.

Toutes les marques SPARC sont utilisées sous licence et sont des marques de fabrique ou des marques déposées de SPARC International, Inc. aux États-Unis et dans d'autres pays. Les produits portant les marques SPARC sont basés sur une architecture développée par Sun Microsystems, Inc. Netscape Navigator et Mozilla est une marques de Netscape Communications Corporation aux États-Unis et dans d'autres pays.

L'interface utilisateur graphique OPEN LOOK et Sun™ a été développée par Sun Microsystems, Inc. pour ses utilisateurs et licenciés. Sun reconnaît les efforts de pionniers de Xerox dans la recherche et le développement du concept des interfaces utilisateur visuelles ou graphiques pour l'industrie informatique. Sun détient une licence non exclusive de Xerox sur l'interface utilisateur graphique Xerox, cette licence couvrant également les licenciés de Sun implémentant les interfaces utilisateur graphiques OPEN LOOK et se conforment en outre aux licences écrites de Sun.

LA DOCUMENTATION EST FOURNIE "EN L'ÉTAT" ET TOUTES AUTRES CONDITIONS, DÉCLARATIONS ET GARANTIES EXPRESSES OU TACITES SONT FORMELLEMENT EXCLUES DANS LA LIMITE DE LA LOI APPLICABLE, Y COMPRIS NOTAMMENT TOUTE GARANTIE IMPLICITE RELATIVE À LA QUALITÉ MARCHANDE, À L'APTITUDE À UNE UTILISATION PARTICULIÈRE OU À L'ABSENCE DE CONTREFAÇON.



Contents

Preface xiii

1. System Overview 1

System Features 1

Supported File Access Protocols 2

Block Access Protocols 2

Network Security and Protocol Integration 2

Supported Clients 3

Network Connection 3

Automatic IP Address Assignment 3

RAID Controllers (Non-Gateway Systems) 3

SAN Storage (Gateway Systems) 3

Data Management 4

Setup and Configuration 4

Client Data Backup 4

Hardware Overview 4

Sun StorageTek 5320 NAS Appliance Server 5

Connecting to an Auxiliary Local UPS 6

Sun StorageTek 5320 NAS Cluster Appliance 6

Sun StorageTek 5320 NAS Gateway System 7

Sun StorageTek 5320 NAS Cluster Gateway System	7
Server Options for All Configurations	7
Back-End Storage	7
SAN Storage	9
Software Overview	10
Web Admin	10
Administrator Console	11
Licensed Options	11
2. Installing Servers and Back-End Storage	13
Standard Cabinets, Racks, and Rail Kits	14
Rack Requirements	14
Slide Rail Kit for Sun StorageTek 5320 NAS Appliance	15
Universal Rail Kit for Back-End Storage	15
Preparing for the Installation	15
Before You Begin	16
Grounding Procedure	16
▼ To Avoid Damage to Internal Components	17
▼ To Ground the Rack Installation	17
Main AC Power Disconnect	17
▼ To Prepare the Server Rackmount Kit	18
▼ To Prepare the Server	18
▼ To Prepare the Universal Rail Kit	18
▼ To Prepare the Controller and Expansion Units	19
▼ To Prepare the Cabinet	20
Installing in the Cabinet	20
▼ To Install the System With a Single Controller Unit	22
▼ To Install the System With Two Controller Units	22
Attaching the Universal Rail Kit to a Cabinet	23

▼ To Attach the Universal Rail Kit to a Cabinet	23
Installing a Unit in a Cabinet	29
Installing a Server in a Cabinet	33
▼ To Install the Slide Rail Assemblies	34
▼ To Install the Cable Management Kit	42
▼ To Verify the Operation of the Slide Rails and the CMA	46
Upgrading a Sun StorageTek 5320 Cabinet	49
Connecting the Power Cables	51
▼ To Connect the Power Cables	51
Back-End Storage Cabling	51
3. Connecting the Sun StorageTek 5320 NAS Appliance	53
Before You Begin	54
Connecting the Sun StorageTek 5320 NAS Appliance to Back-End Storage	54
Connecting the Sun StorageTek 5320 NAS Appliance to the Controller Unit	54
▼ To Connect One Controller Unit	56
▼ To Connect One Controller Unit to Two HBA Cards	57
▼ To Connect Two Controller Units	57
Connecting Controller Units to Expansion Units	59
▼ To Cable a Controller Unit to One Expansion Unit	60
▼ To Cable a Controller Unit to Two Expansion Units	61
▼ To Cable a Controller Unit to Three Expansion Units	62
▼ To Cable a Controller Unit to Six Expansion Units	65
Connecting Existing Sun StorEdge 5300 Controller Enclosures to New Sun StorageTek 5320 Expansion Units	67
Cabling a Single Expansion Unit to a Controller Enclosure with FC Drives	67
▼ To cable a Controller Enclosure to a Single Expansion Unit	67
Cabling Two Expansion Units to a Controller Enclosure	68

- ▼ To Cable a Controller Enclosure to Two Expansion Units 69
- Cabling a Single Expansion Unit to a 5300 SATA Controller Enclosure 71
- ▼ To Cable a Controller Enclosure with SATA Drives to an Expansion Unit 71
- Upgrade Firmware on Expansion Units and Enclosures 72
- Connecting to the Network 73
 - ▼ To Connect to Copper Fast Ethernet or Gigabit Ethernet Networks 73
 - ▼ To Connect to Optional Optical Gigabit Ethernet Networks 73
- Powering On the Sun StorageTek 5320 NAS Appliance, Controller Units, and Expansion Units 74
 - ▼ To Initially Power On the Sun StorageTek 5320 NAS Appliance and Controller Unit 75
 - ▼ To Initially Power On the Sun StorageTek 5320 NAS Appliance, Controller Units, and Expansion Units 76
 - ▼ To Power On the Sun StorageTek 5320 NAS Appliance System After Initial Power-On 77
- Initial Sun StorageTek 5320 NAS Appliance Configuration 78
 - IP Address Configuration 79
 - Automatic (DHCP) IP Address Configuration 79
 - ▼ To Configure the IP Address Manually 79
 - Accessing the Web Administrator 80
 - ▼ To Connect to the Web Administrator 80
- 4. Installing the Sun StorageTek 5320 NAS Cluster Appliance 83**
 - Before You Begin 84
 - Connecting the Sun StorageTek 5320 NAS Cluster Appliance to Back-End Storage 84
 - Connecting the Sun StorageTek 5320 NAS Cluster Appliance to Controller Units 84
 - ▼ To Connect One Controller Unit 86
 - ▼ To Connect Two Controller Units 87

Connecting the Controller Units to Expansion Units	90
▼ To Cable a Controller Unit to One Expansion Unit	91
▼ To Cable a Controller Unit to Two Expansion Units	92
▼ To Cable a Controller Unit to Three Expansion Units	93
▼ To Cable a Controller Unit to Six Expansion Units	96
Connecting the Server Health-Monitoring and Network Cables	98
▼ To Connect the Health-Monitoring Cable	98
▼ To Connect to Optical Gigabit Ethernet Networks	98
▼ To Connect to Copper Fast Ethernet or Gigabit Ethernet Networks	99
Powering On the Sun StorageTek 5320 NAS Cluster Appliance, Controller Units, and Expansion Units	100
▼ To Initially Power On the Sun StorageTek 5320 NAS Cluster Appliance and Controller Unit	100
▼ To Initially Power On the Sun StorageTek 5320 NAS Cluster Appliance, Controller Unit, and Expansion Unit	102
▼ To Power On the Sun StorageTek 5320 NAS Cluster Appliance System After Initial Power-On	104
Initial Sun StorageTek 5320 NAS Cluster Appliance Configuration	105
▼ To Set IP Addresses	105
▼ To Configure the System	107
▼ To Assign LUN Ownership	108
▼ To Assign LUN Paths	109
▼ To Configure the Partner	109
5. Installing the Sun StorageTek 5320 NAS Gateway System	111
Before You Begin	112
Installation and Configuration Task Overview	113
Storage Concepts	114
Connecting the Sun StorageTek 5320 NAS Gateway System to the Sun StorageTek 6130/6140/6540 Array	114
Sun StorageTek 6540 Array Controller Ports	115

Required Software and Firmware	115
Sun StorageTek 6140 Array Controller Ports	116
Connecting Directly to the Sun StorageTek 6130/6140/6540 Array	116
▼ To Connect a Single-Server Direct Attach to the Sun StorageTek 6130/6140/6540 Array	116
▼ To Connect a Dual-Server Direct Attach to the Sun StorageTek 6130/6140/6540 Array	118
Using Fabric Switches to Connect to the Sun StorageTek 6130/6140/6540 Array	120
▼ To Connect a Single-Server Fabric Attach to the Sun StorageTek 6130/6140/6540 Array	120
▼ To Share All Sun StorageTek 6130 Array LUNs Between All Port Pairs	122
▼ To Connect a Dual-Server High-Availability Fabric Attach to the Sun StorageTek 6130/6140/6540 Array	124
Connecting the Gateway System to the Sun StorageTek FlexLine 200 and 300 Series	126
Connecting Directly to the FlexLine 200 and 300 Series	126
▼ To Connect a Single-Server Direct Attach to the Sun StorageTek FlexLine 200 and 300 Series	126
▼ To Connect a Dual-Server Direct Attach to the Sun StorageTek FlexLine 200 and 300 Series	127
Using Fabric Switches to Connect to the Sun StorageTek FlexLine 200 and 300 Series	128
▼ To Connect a Single-Server Fabric Attach to the Sun StorageTek FlexLine 200 and 300 Series	129
▼ To Connect a Dual-Server High-Availability Fabric Attach to the Sun StorageTek FlexLine 200 and 300 Series	130
Sun StorageTek FlexLine 200 and 300 Series Gateway Configuration	134
Modifying the Host Type on the Sun StorageTek FlexLine 200 and 300 Series Array	134
Changing the Host Type Region on the Scripts	135
Connecting the Sun StorageTek 5320 NAS Gateway System to the Sun StorEdge 6920 System	135

Connecting Directly to the Sun StorEdge 6920 System 136

- ▼ To Connect a Single-Server Direct Attach to the Sun StorEdge 6920 System 136
- ▼ To Connect a Dual-Server Direct Attach to the Sun StorEdge 6920 System 137

Using Fabric Switches to Connect to the Sun StorEdge 6920 System 139

- ▼ To Connect a Single-Server Fabric Attach to the Sun StorEdge 6920 System 139
- ▼ To Connect Dual-Server High-Availability Fabric Attach to the Sun StorageTek 6920 System 140

Connecting the Gateway System or Gateway Cluster System to the Sun StorEdge 99xx System 145

Connecting Directly to the Sun StorEdge 99xx System 145

- ▼ To Connect a Single-Server Direct Attach to the Sun StorEdge 99xx System 145
- ▼ To Connect a Dual-Server Direct Attach to the Sun StorEdge 99xx System 146

Using Fabric Switches to Connect to the Sun StorEdge 99xx System 148

- ▼ To Connect a Single-Server Fabric Attach to the Sun StorEdge 99xx System 148
- ▼ To Connect an Independent Dual-Server Fabric Attach to the Sun StorEdge 99xx System 149
- ▼ To Connect a Dual-Server High-Availability Fabric Attach to the Sun StorEdge 99xx System 151

Connecting to the Network 154

Connecting Single Servers 154

- ▼ To Connect to a 100BASE-T Fast Ethernet Network or to a 1000BASE-T Gigabit Network 154
- ▼ To Connect to an Optical Gigabit Ethernet Network 155

Connecting Dual-Server HA Servers 155

- ▼ To Connect the Health-Monitoring Cable 156
- ▼ To Connect to a Fast Ethernet or Gigabit Ethernet Network 156

▼	To Connect to an Optical Gigabit Ethernet Network	156
	Powering On the Gateway System	156
▼	To Power On the Gateway System	157
	Initial Gateway System Single-Server Configuration	159
▼	To Set the IP Address	159
	Configuring the Single-Server System	160
▼	To Set Up Basic Configuration	160
▼	To Activate the Sun StorageTek NAS Gateway License	162
▼	To Configure Storage on the Sun StorageTek 5320 NAS Gateway System Single Server	164
	Initial Cluster Gateway System Configuration	166
▼	To Set IP Addresses	166
	Basic Dual-Server System Configuration	167
▼	To Set Up Basic Configuration	167
▼	To Activate the Sun StorageTek NAS Gateway License	169
▼	To Set Up Server H2	170
▼	To Configure SAN Storage on the Cluster Gateway System	170
▼	To Configure Storage on the Cluster Gateway System	170
▼	To Configure Failover	171
▼	To Assign LUNs to Server H2	172
▼	To Configure LUN Paths	173
	SAN Storage Configuration	173
	Sun StorageTek 6130 Array	173
▼	To Upgrade the Sun StorageTek 6130 Array Management Software	174
▼	To Upgrade the Sun StorageTek 6130 Array Firmware	175
	Verifying the Array	175
▼	To Automatically Verify the Array	175
▼	To Manually Register the Array	176

Making the Sun StorageTek 6130 Array SAN Storage Available 176

- ▼ To Create an Initiator 177
- ▼ To Define a Sun StorageTek 6130 Volume 177
- ▼ To Define a NAS 5320 Volume 177

Sun StorageTek 6140 Array 178

- ▼ To Configure Storage on the Sun StorageTek 6140 Array 178
- ▼ To Configure Storage on the Sun StorEdge 6920 System 178
- ▼ To Configure Storage on the Sun StorEdge 99xx System 179

A. Hardware Technical Specifications 181

B. Third-Party License Agreements 183

Glossary 199

Index 203

Preface

The *Sun StorageTek 5320 NAS Appliance and Gateway System Getting Started Guide* is a combined installation, configuration, and getting started guide for the Sun StorageTek™ 5320 NAS Appliance, the Sun StorageTek 5320 NAS Cluster Appliance, the Sun StorageTek 5320 NAS Gateway System, and the Sun StorageTek 5320 NAS Cluster Gateway System. This guide describes how to install rackmounting rails, servers, and back-end storage; how to connect servers and storage; and how to configure the system.

Before You Read This Document

Before you begin to install the system, you must have already prepared the site as described in these books:

- *Sun StorageTek 5320 NAS Appliance and Gateway System Storage Regulatory and Safety Compliance Manual*
- *Sun StorageTek 5320 NAS Array Regulatory and Safety Compliance Manual* (if using back-end storage arrays)
- *Sun Rack Installation Guide*

How This Document Is Organized

This guide contains instructions for installing and configuring all variations of the Sun StorageTek 5320 NAS Appliance, the Sun StorageTek 5320 NAS Cluster Appliance, the Sun StorageTek 5320 NAS Gateway System, and the Sun StorageTek 5320 NAS Cluster Gateway System. You need to read only the chapters pertinent to your installation.

[Chapter 1](#) provides an overview of system features.

[Chapter 2](#) describes rai mounting, and is applicable to server and back-end storage installation.

[Chapter 3](#) describes how to set up the Sun StorageTek 5320 NAS Appliance with back-end storage (Sun StorageTek 5300 RAID Controller Enclosure and optional Sun StorEdge 5300 Expansion Enclosures) and applies only to that setup.

[Chapter 4](#) describes how to set up the Sun StorageTek 5320 NAS Cluster Appliance with back-end storage (Sun StorageTek 5300 RAID Controller Enclosure and optional Sun StorEdge 5300 Expansion Enclosures) and applies only to that setup.

[Chapter 5](#) describes how to set up the Sun StorageTek 5320 NAS Gateway System or the Sun StorageTek 5320 NAS Cluster Gateway System with SAN storage and applies only to those setups.

[Appendix A](#) is a brief technical specification of the Sun StorageTek 5320 NAS Appliance system hardware.

[Appendix B](#) details third-party license agreements.

Glossary is a list of words and phrases and their definitions.

Index is an alphabetical list of topics.

Typographic Conventions

Typeface*	Meaning	Examples
AaBbCc123	The names of commands, files, and directories; on-screen computer output	Edit your <code>.login</code> file. Use <code>ls -a</code> to list all files. % You have mail.
AaBbCc123	What you type, when contrasted with on-screen computer output	% su Password:
<i>AaBbCc123</i>	Book titles, new words or terms, words to be emphasized. Replace command-line variables with real names or values.	Read Chapter 6 in the <i>User's Guide</i> . These are called <i>class</i> options. You <i>must</i> be superuser to do this. To delete a file, type <code>rm filename</code> .

* The settings on your browser might differ from these settings.

Related Documentation

The documents listed as online are available at

http://www.sun.com/hwdocs/Network_Storage_Solutions/nas.

Application	Title	Part Number	Format	Location
Installation	<i>Sun StorageTek 5000 OS NAS Software Release Notes</i>	819-5467- <i>nn</i>	PDF	Online
NAS Appliance installation (non-Gateway)	<i>Sun StorageTek 5320 NAS Appliance Setup</i>	819-4385- <i>nn</i>	Printed PDF	Shipping kit Online
Gateway	<i>Sun StorageTek 5320 NAS Gateway System Setup</i>	819-4286- <i>nn</i>	Printed PDF	Shipping kit Online
GUI usage	<i>Sun StorageTek 5320 NAS OS Administration Guide</i>	819-4284- <i>nn</i>	PDF	Online
Safety	<i>Sun StorageTek 5320 NAS Appliance and Gateway System Storage Regulatory and Safety Compliance Manual</i>	819-7315- <i>nn</i>	PDF	Online
Safety	<i>Sun StorageTek 5320 NAS Array Regulatory and Safety Compliance Manual</i>	819-6048- <i>nn</i>	PDF	Online

Documentation, Support, and Training

Sun Function	URL
Documentation	http://www.sun.com/documentation/
Support	http://www.sun.com/support/
Training	http://www.sun.com/training/

Third-Party Web Sites

Sun is not responsible for the availability of third-party web sites mentioned in this document. Sun does not endorse and is not responsible or liable for any content, advertising, products, or other materials that are available on or through such sites or resources. Sun will not be responsible or liable for any actual or alleged damage or loss caused by or in connection with the use of or reliance on any such content, goods, or services that are available on or through such sites or resources.

Sun Welcomes Your Comments

Sun is interested in improving its documentation and welcomes your comments and suggestions. You can submit your comments by going to:

<http://www.sun.com/hwdocs/feedback>

Please include the title and part number of your document with your feedback:

Sun StorageTek 5320 NAS Appliance and Gateway System Getting Started Guide, part number 819-4283-12.

System Overview

This chapter describes the components and terminology of the Sun StorageTek 5320 NAS Appliance, the Sun StorageTek 5320 NAS Cluster Appliance, the Sun StorageTek 5320 NAS Gateway System, and the Sun StorageTek 5320 NAS Cluster Gateway System. It includes the following sections:

- [“System Features” on page 1](#)
 - [“Hardware Overview” on page 4](#)
 - [“Software Overview” on page 10](#)
-

System Features

The Sun StorageTek 5320 NAS Appliance is the Sun Microsystems modular, scalable, network-attached storage (NAS) solution and is available in several configurations:

- Sun StorageTek 5320 NAS Appliance single server, with controller unit and optional expansion units available for back-end storage
- Sun StorageTek 5320 NAS Cluster Appliance with two NAS servers for high availability and failover protection, with controller unit and optional expansion units available for back-end storage
- Sun StorageTek 5320 NAS Gateway System single server that shares storage with other servers in a storage area network (SAN)
- Sun StorageTek 5320 NAS Cluster Gateway System with two servers in a cluster configuration (for high availability and failover protection) that share storage with other servers in a SAN

Note – For the most current support information, contact your Sun sales representative.

Supported File Access Protocols

- Microsoft networks (CIFS/SMB)
- UNIX® (NFS V2 and V3)
- File Transfer Protocol (FTP)

Block Access Protocols

- iSCSI
- SCSI Initiator
- iSCSI Boot

Network Security and Protocol Integration

- Network Logon (Netlogon) client
- Microsoft Windows Domain support
- Multiple Master Domain (MMD) support
- CIFS Security Descriptors (SD) on files and directories
- Discretionary Access Control Lists (DACL) on files and directories
- NIS
- NIS+
- Unicode
- Microsoft Windows Active Directory Service (ADS) support
- Microsoft Windows Dynamic DNS support
- Microsoft Windows-compatible Kerberos (v5) security
- Microsoft Windows-compatible Lightweight Directory Access Protocol (LDAP)
- LDAP authentication for NFS
- Network Time Protocol (NTP)
- Rdate command
- syslogd Remote Logging
- Simple Network Management Protocol (SNMP)
- NDMP V4
- TrendMicro Antivirus Software

Supported Clients

A client is any computer on the network that requests file services from the Sun StorageTek 5320 NAS Appliance. In general, if a client implementation follows the NFS version 2 or 3 protocol or the CIFS specifications, it is supported with the Sun StorageTek 5320 NAS Appliance, the Sun StorageTek 5320 NAS Cluster Appliance, the Sun StorageTek 5320 NAS Gateway System, and the Sun StorageTek 5320 NAS Cluster Gateway System.

Network Connection

- Autosensing 10/100/1000BASE-TX RJ-45 network connectors
- Optional dual port optical Gigabit Ethernet network interface cards (NICs)
- Optional dual port copper 10/100/1000 Ethernet NIC cards

Automatic IP Address Assignment

Supports Dynamic Host Configuration Protocol (DHCP) and Address Resolution Protocol (ARP) for automatic assignment of IP address

RAID Controllers (Non-Gateway Systems)

Controller unit containing two controllers configured for Fibre Channel (FC) or for Serial ATA (SATA) disk drives

SAN Storage (Gateway Systems)

Direct attachment or fabric connection to the Sun StorageTek 6130/6140/6540 array, Sun StorageTek FlexLine 280 and 380 systems, Sun StorEdge 6920 system, Sun StorEdge 9970/9980/9985/9990 systems.

Note – Refer to the Sun StorageTek 5320 NAS Gateway System web page for the most current SAN storage information.

Data Management

- Sun StorageTek File Checkpoint facility enables users to recover accidentally damaged or deleted data with a simple file copy operation
- Directory tree quotas
- User and group quotas

Setup and Configuration

- Web-based user interface for system configuration and administration
- Command-line and console menu interface (refer to the *Sun StorageTek 5320 NAS OS Administration Guide*)

Client Data Backup

- Network Data Management Protocol (NDMP), V2 minimum
- Enterprise Backup Software, version 7.2 minimum
- Veritas NetBackup, 5.x minimum
- Compatible with BakBone NetVault 7 minimum, supported by BakBone

Note – Refer to the Sun StorageTek 5320 NAS Appliance product web page for the most current backup information.

Hardware Overview

The following system configurations are available:

- Sun StorageTek 5320 NAS Appliance with back-end storage
- Sun StorageTek 5320 NAS Cluster Appliance with back-end storage
- Sun StorageTek 5320 NAS Gateway System (single server) with SAN storage
- Sun StorageTek 5320 NAS Cluster Gateway System high-availability dual server in a cluster configuration with SAN storage

The sections that follow describe each of the system components.

Sun StorageTek 5320 NAS Appliance Server

The Sun StorageTek 5320 NAS Appliance server is the basic server unit for all system configurations. [FIGURE 1-1](#) shows the front of the server.

FIGURE 1-1 Sun StorageTek 5320 NAS Appliance Front View

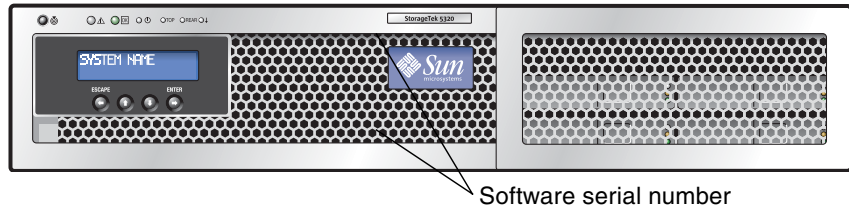

Note – The software serial number, located on a printed label at the front of the server, identifies a matched pair (“-H1” or “-H2”) of Sun StorageTek 5320 NAS cluster appliance. The serial number is needed to get licences.

In the Sun StorageTek 5320 NAS Appliance configuration, the server can contain one or two dual port FC host bus adapter (HBA) cards in PCI slot 1 (standard) and PCI slot 0 and other options (see [“Server Options for All Configurations” on page 7](#)). [FIGURE 1-2](#) shows the back of the server.

FIGURE 1-2 Sun StorageTek 5320 NAS Appliance Back Panel With Single HBA Card

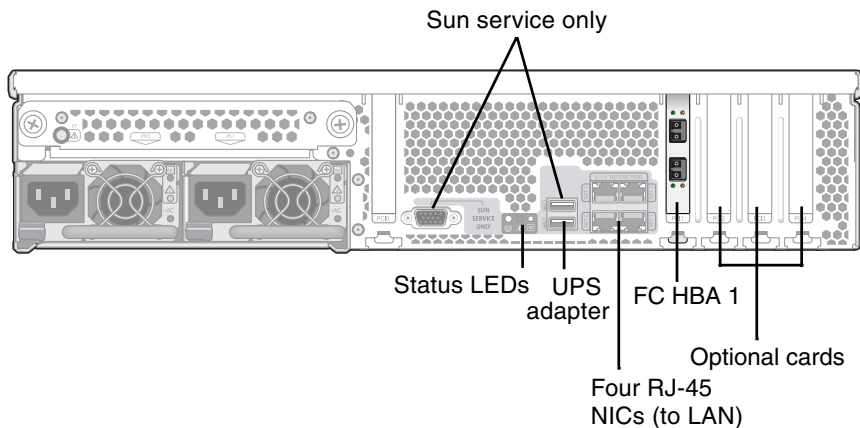

Connecting to an Auxiliary Local UPS

The USB-to-Serial Port Adapter/Convert Cable (included in the ship kit) can be used to connect to a supported local UPS (uninterrupted power supply) device. Connecting the UPS adapter cable to a supported local UPS device enables the NAS appliance to monitor the state of the UPS. If a power outage occurs, the UPS provides for a graceful shutdown of the system.

Sun StorageTek 5320 NAS Cluster Appliance

In the Sun StorageTek 5320 NAS Cluster Appliance configuration, two high-availability (HA) servers are sold as a matched pair and are identified as server “-H1” and server “-H2” in their software serial numbers. Each server contains two dual port FC HBA cards and can contain other optional cards (see [“Server Options for All Configurations” on page 7](#)). **FIGURE 1-3** shows the back of the server with two HBA cards.

FIGURE 1-3 Sun StorageTek 5320 NAS Appliance Back Panel With Two HBA Cards

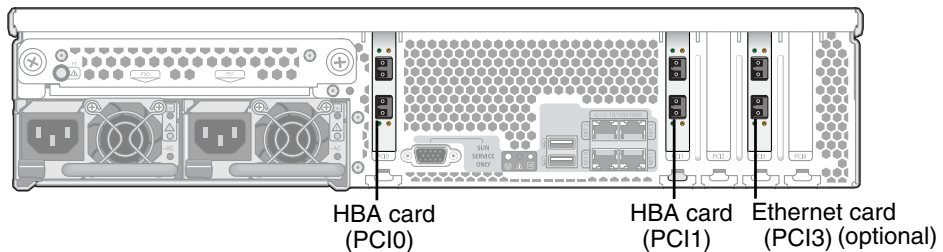

Sun StorageTek 5320 NAS Gateway System

In the Sun StorageTek 5320 NAS Gateway System single-server configuration, the server contains two dual port HBA cards and can contain other optional cards (see [“Server Options for All Configurations” on page 7](#)).

Sun StorageTek 5320 NAS Cluster Gateway System

In the Sun StorageTek 5320 NAS Cluster Gateway System configuration, the servers are sold as a matched pair and are identified as server “-H1” and server “-H2.” Each server contains two dual port FC HBA cards and can contain other optional cards (see [“Server Options for All Configurations” on page 7](#)).

Server Options for All Configurations

Other options for all server configurations include the following:

- Up to three optional dual port copper 10/100/1000 Gigabit Ethernet cards (PCI slots 2 through 4)
- Up to three optional dual port optical Gigabit Ethernet cards (PCI slots 2 through 4)
- A SCSI HBA card or a FC card for tape backup (PCI slot 2)

There are two kinds of Sun StorEdge 5320 EU Expansion Enclosures that can be used with the controller enclosures: Sun StorEdge 5320 EU F (Fibre Channel disk drives only) and Sun StorEdge 5320 EU S (SATA disk drives only).

Back-End Storage

The Sun StorageTek 5320 RAID Controller Unit (CU) provides direct-attached back-end storage for the Sun StorageTek 5320 NAS Appliance or Sun StorageTek 5320 NAS Cluster Appliance. Systems can be set up with one or two controller units using all Fibre Channel or all SATA disk drives in a single CU. [FIGURE 1-4](#) shows the front of the CU.

FIGURE 1-4 Sun StorageTek 5320 RAID Controller Unit Front



FIGURE 1-5 shows the back of the CU.

FIGURE 1-5 Sun StorageTek 5320 RAID Controller Unit Back

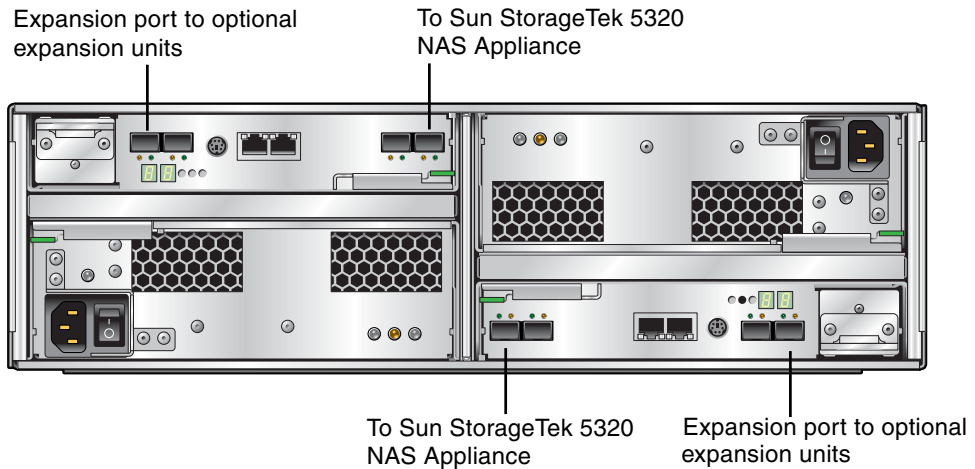

Each Sun StorEdge 5300 Expansion Enclosure that attaches to a controller unit must contain only Fibre Channel (FC) disk drives or only SATA disk drives. FC expansion units or SATA expansion units can be mixed in an array, so that some of each can be attached to one controller. FIGURE 1-6 shows the front of the 5320 expansion unit.

FIGURE 1-6 Sun StorEdge 5300 Expansion Enclosure Front



FIGURE 1-7 shows the back of the EU.

FIGURE 1-7 Sun StorEdge 5300 Expansion Enclosure Back

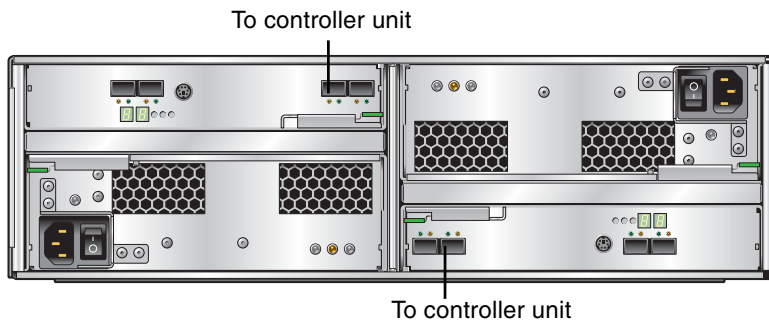

SAN Storage

The Sun StorageTek 5320 NAS Gateway System can connect directly or through fabric switches to the following types of SAN storage:

- Sun StorEdge 6130/6140/6540 array
- Sun StorEdge FlexLine™ 280 and 380 storage systems
- Sun StorEdge 6920 system
- Sun StorEdge 9970/9980/9985/9990 systems

Note – Refer to the Sun StorageTek 5320 NAS Gateway System web page for the most current SAN storage information.

Software Overview

There are three major software components to consider, described in the following sections:

- “Web Admin” on page 10
- “Administrator Console” on page 11
- “Licensed Options” on page 11

The software is described in detail in the *Sun StorageTek 5320 NAS OS Administration Guide*.

Web Admin

The Sun StorageTek 5320 NAS Appliance ships with the Web Admin software installed. Other than a standard web browser, you do not need to install any software to manage your system.

The Web Admin graphical user interface (GUI) is easy to use and lets you configure system parameters through a series of menus and screen panels. These settings are discussed in the *Sun StorageTek 5320 NAS OS Administration Guide*.

To access the Web Admin management interface, you must be running Microsoft Windows 98/NT/2000/XP/2003, Sun Solaris™ Operating System (Solaris OS) 5.7 (minimum version), or Red Hat Linux software.

Microsoft Windows users require one of these browsers:

- Internet Explorer 5.5 (minimum version) on systems using Microsoft Windows 98/NT/2000/XP/2003
- Netscape™ software 4.77 (minimum version) on systems using Microsoft Windows 98/NT/2000/XP/2003 and Solaris OS. *Netscape 6.0 and 6.01 are not supported.*

Solaris OS and Red Hat Linux users require one of the following browsers:

- Netscape™ software 4.77 (minimum version) on systems using Microsoft Windows 98/NT/2000/XP/2003 and Solaris OS. *Netscape 6.0 and 6.01 are not supported.*
- Mozilla™ browser.
- Java™ platform-enabled browser with Java Plug-in 1.4 (minimum version).

Note – To download the latest Java Plug-in, go to <http://java.com>.

Administrator Console

An alternative to the Web Admin is the administrator console. You can use a number of protocols such as Telnet, SSH, or RLogin to connect to the administrator console as long as the application you use has an ANSI-compatible terminal emulator. The administrator console is described in Appendix A in the *Sun StorageTek 5320 NAS OS Administration Guide*.

Licensed Options

There are several licensed options you can purchase for the system. The following options are available:

- Sun StorageTek File Replicator, which enables you to duplicate data from one volume onto a mirrored volume on a different Sun StorageTek 5320 NAS Appliance, Sun StorageTek 5320 NAS Gateway System, or Sun StorageTek 5320 NAS Cluster Gateway System
- Sun StorageTek Compliance Archiving Software, which allows you to enable volumes to follow advisory or mandatory enforcement of compliance archiving guidelines for data retention and protection

Note – Only advisory enforcement compliance archiving is supported on the Sun StorageTek 5320 NAS Gateway System.

- Sun StorageTek NAS Gateway System, which enables you to use your system as a gateway connection to SAN storage

The options and how to activate them are described in Chapter 9 in the *Sun StorageTek 5320 NAS OS Administration Guide*.

Installing Servers and Back-End Storage

Use the procedures in this chapter to install Sun StorageTek 5320 NAS Appliance servers and back-end storage.

Note – This chapter generically describes how to install a server, which applies to the Sun StorageTek 5320 NAS Appliance, the Sun StorageTek 5320 NAS Cluster Appliance, the Sun StorageTek 5320 NAS Gateway System, and the Sun StorageTek 5320 NAS Cluster Gateway System. Back-end storage installation is for each Sun StorageTek 5320 RAID Controller Unit and each Sun StorEdge 5300 Expansion Enclosure as used with the Sun StorageTek 5320 NAS Appliance and Sun StorageTek 5320 NAS Cluster Appliance.

This chapter describes the process of installing Sun StorageTek 5320 NAS Appliance servers, controller units, and expansion units. It contains the following sections:

- [“Standard Cabinets, Racks, and Rail Kits” on page 14](#)
- [“Preparing for the Installation” on page 15](#)
- [“Installing in the Cabinet” on page 20](#)
- [“Attaching the Universal Rail Kit to a Cabinet” on page 23](#)
- [“Installing a Unit in a Cabinet” on page 29](#)
- [“Installing a Server in a Cabinet” on page 33](#)
- [“Connecting the Power Cables” on page 51](#)
- [“Back-End Storage Cabling” on page 51](#)

The installation procedures in this chapter require the following items:

- No. 2 Phillips screwdriver
- No. 3 Phillips screwdriver
- Antistatic protection



Caution – Electrostatic discharge can damage sensitive components. Touching the array or its components without using a proper ground might damage the equipment. To avoid damage, use proper antistatic protection before handling any components.

Standard Cabinets, Racks, and Rail Kits

Although the system is installed in a single cabinet or rack, the server and the back-end storage units require different rail kits.

Rack Requirements

Rack requirements to support installation are:

- Rack horizontal opening and unit vertical pitch conforming to ANSI/EIA 310-D-1992 or IEC 60927
- Four-post structure (mounting at both front and back)
- Distance between front and back mounting planes between 610 mm and 915 mm (24 to 36 inches)
- Clearance depth (to front cabinet door) in front of front rackmounting plane at least 25.4 mm (1 inch)
- Clearance depth (to back cabinet door) behind front rackmounting plane at least 800 mm (31.5 inches), or 700 mm (27.5 inches) without cable management arm
- Clearance width (between structural supports, cable troughs, and the like) between front and back mounting planes at least 456 mm (18 inches)

Note – Not all third-party racks meet these parameters and are compatible with these slide rail kits. Also, some third-party rack vendors do not support a completely filled rack with this type of server, due to the amount of power required.

Server rack density varies widely based on systems installed, power distribution installation (in-cabinet, external), power source (single-phase, three-phase), and whether redundant power is required.

For power specifications, refer to [Appendix A](#).

Slide Rail Kit for Sun StorageTek 5320 NAS Appliance

Field installation of the Sun StorageTek 5320 NAS Appliance in the Sun Fire™ Hardware Expansion Cabinet and third-party ANSI/EIA 310-D-1992 or IEC 60927 compliant cabinets is supported with the slide rail kit (370-7669-02) and cable management arm (370-7668-02).

The slide rail kit is a 4-point mounted slide rail kit and is designed to enable the Sun StorageTek 5320 NAS Appliance to be racked in the Sun™ Rack 900, the Sun Rack 1000, and third-party ANSI/EIA 310-D-1992 or IEC 60927 compliant racks. No other kits are available to allow 2-post, front-mount, or mid-mount configuration.

The slide kit includes hardware that enables mounting to any of the following types of rack rails:

- 6 mm threaded holes
- No. 10-32 threaded holes
- No. 10 clearance holes
- Square unthreaded holes per EIA and IEC standards listed above

Universal Rail Kit for Back-End Storage

Use the universal rail kit to mount the controller and expansion units in any standard Sun cabinet, such as the Sun Rack 900/1000 cabinet.

Preparing for the Installation

Use the following procedures to prepare for installation:

- [“Before You Begin” on page 16](#)
- [“Grounding Procedure” on page 16](#)
- [“To Prepare the Server Rackmount Kit” on page 18](#)
- [“To Prepare the Universal Rail Kit” on page 18](#)
- [“To Prepare the Controller and Expansion Units” on page 19](#)
- [“To Prepare the Server” on page 18](#)
- [“To Prepare the Cabinet” on page 20](#)

Before You Begin

Before you begin rackmounting, do the following:

- Check that the maximum ambient operating temperature in the rack does not exceed 95° F (35° C).
- Pick a location that allows unrestricted air flow for the cooling fans.
- Make sure that mounting the units into the rack will not tip over the rack, even when the units are fully extended from the rack.
- Install the components so that the rack is stable. Begin loading from the bottom of the rack to the top.



Caution – Uneven loading of the rack can cause dangerous instability.

- Make sure the rack cabinet has two power sources connected to two separate power circuits.
- Make sure the power outlets are close enough to the units for the power cords to reach the cabinet properly and supply power to the units.
- Make sure the power cables are properly grounded.

Grounding Procedure

You must maintain reliable grounding of this equipment. Review specifications in Appendix A to determine the appropriate AC branch circuit size for the quantity of units in your configuration and your operating voltage. Always follow your local electrical codes for loading circuits.



Caution – The Sun StorageTek 5320 NAS Appliance, controller enclosure, and expansion units contain several components sensitive to static-electrical discharge. Surges of static electricity (caused by shuffling your feet across a floor and touching a metallic surface, for example) can cause damage to electrical components. For this reason, it is important that proper packaging and grounding techniques be observed. Follow the procedures below.

- Transport products in static-safe containers.
- Cover workstations with approved static-dissipating material.
- Wear a wrist strap, and always be properly grounded when touching static-sensitive equipment or parts.
- Use only properly grounded tools and equipment.
- Avoid touching pins, leads, or circuitry.

▼ To Avoid Damage to Internal Components

1. For each controller enclosure and expansion unit, make sure that the power switch is turned off and that both power cables are plugged in.
2. Wear a wrist strap, and always be properly grounded when touching static-sensitive equipment or parts.
If a wrist strap is not available, touch any unpainted metal surface on the back panel of any unit to dissipate static electricity. Repeat this procedure several times during installation.
3. Avoid touching exposed circuitry, and handle components by their edges only.



Caution – Do not power on any units until after you have connected the Sun StorageTek 5320 NAS Appliance to the network.

▼ To Ground the Rack Installation

1. Include a third-wire safety ground conductor with the rack installation to avoid the potential for an electrical shock hazard.
2. Use a minimum 14 AWG connected to the earth ground stud on the back of the server.
3. Connect the safety ground conductor to the chassis stud with a two-hole crimp terminal with a maximum width of 0.25 inch.
4. Install the nuts on the chassis with a 10 in/lb torque.

The safe ground conductor provides proper grounding only for the Sun StorageTek 5320 NAS Appliance. You must provide additional proper grounding for the rack and other devices installed in it.

Review specifications in Appendix A to determine isolation and continuous power requirements.

Main AC Power Disconnect

You are responsible for installing an AC power disconnect for the entire rack unit. This power source disconnect must be readily accessible, and it must be labeled as controlling power to the entire rack unit, not only to the servers.

▼ To Prepare the Server Rackmount Kit

- **Ensure that you have all of the parts in the rackmount kit before you begin the installation of the server:**
 - Slide rail assemblies
 - Package of mounting screws and nuts in assorted sizes to fit various types of racks and cabinets
 - Cable management arm with six preinstalled cable clips
 - Manufacturer's instruction sheet for the cable management arm

The rackmount kit contains two slide rail assemblies. A slide rail assembly can be installed on either the right or left side of the rack.

A slide rail assembly consists of two parts: a slide rail and a removable mounting bracket. The slide rail attaches to the rack posts. The mounting bracket attaches to the server chassis.

▼ To Prepare the Server

1. **Unpack the unit.**
2. **Check the contents of the box for the following items:**
 - Sun StorageTek 5320 NAS Appliance or Sun StorageTek 5320 NAS Cluster Appliance or Sun StorageTek 5320 NAS Gateway System (single server or dual server)
 - Ship kit for the server
3. **Be sure you have the power cords (two per server), which were shipped separately.**

▼ To Prepare the Universal Rail Kit

Use the universal rail kit to mount controller and expansion units in the Sun Rack 900 or Sun Rack 1000 cabinet.

- **Unpack the universal rail kit and check the contents.**

The universal rail kit (part number 370-7669-02) contains the following items:

- Twelve 10-32 panhead screws
- Eight M6x12mm panhead screws
- Four 8-32 panhead screws

- Two 6-32 flathead screws
- Two cabinet rail adapter plates (used for unthreaded cabinet rails only)
- Mounting hardware as listed below:

Type	Quantity	Use
10-32 panhead screw	8	Assemble main and extender sections of left and right rails (Typically, left and right rails are shipped pre-assembled)
8-32 panhead screw	4	Mount left and right rails to front of cabinet rails
Metric M6 panhead screw	4	Mount left and right rails to back of cabinet rails
Metric M6 panhead screw	4	Secure front of tray to left and right cabinet rails
6-32 flathead screw	2	Secure back of tray to left and right side rails

▼ To Prepare the Controller and Expansion Units



Caution – Two people are needed to lift and move the controller unit and expansion units. Use care to avoid injury. A unit can weigh up to 95 pounds (43 kg). Do not lift by the front of the unit; this can cause damage to the drives.

1. Unpack the unit.

2. Check the contents of the box for the following items:

- Sun StorageTek 5320 RAID Controller Unit or Sun StorEdge 5300 Expansion Enclosure
- Ship kit for the controller unit:
 - *Sun StorageTek 5320 Appliance Setup* poster
 - *Accessing Documentation* guide
 - *Sun StorageTek 5320 NAS Array Regular toy and Safety Compliance Manual*
- Ship kit for the expansion unit:
 - Two 2-meter Fiber LC to LC cables
 - Four Optical SFP transceivers
 - *Accessing Documentation* guide
 - Important Notice for 5300 Upgrade

▼ To Prepare the Cabinet

Select the cabinet in which you will be installing the Sun StorageTek 5320 NAS Appliance. Be sure the cabinet is installed as described in the installation instructions provided with it.

1. **Stabilize the cabinet as described in the cabinet documentation.**
2. **If the cabinet has casters, make sure the casters are locked to prevent the cabinet from rolling.**
3. **Remove or open the top front panel.**
4. **Remove or open the vented back panel.**

Note – Sun Microsystems makes no warranties or guarantees as to fit, form, or function of the Sun StorageTek 5320 NAS Appliance system installed in third-party racks or cabinets. It is the customer’s responsibility to ensure that the rack or cabinet can house the Sun StorageTek 5320 NAS Appliance system in all conditions that might exist. All racks and cabinets must comply with local building and construction codes.

Installing in the Cabinet

You must plan your installation carefully.

The controller and expansion must be installed in the cabinet as follows, always starting from the bottom up. Starting at the bottom distributes the weight correctly in the cabinet.

Note – If you are installing a mixture of FC and SATA expansion units, be sure to install the SATA expansion units first, followed by the FC expansion units. Installing in this order enables you to install either a SATA or FC expansion unit without requiring an outage.

FIGURE 2-1 shows the cabinet with a single controller enclosure, single expansion unit, room for additional storage, and single server installed at the top.

FIGURE 2-1 Rackmounting Order

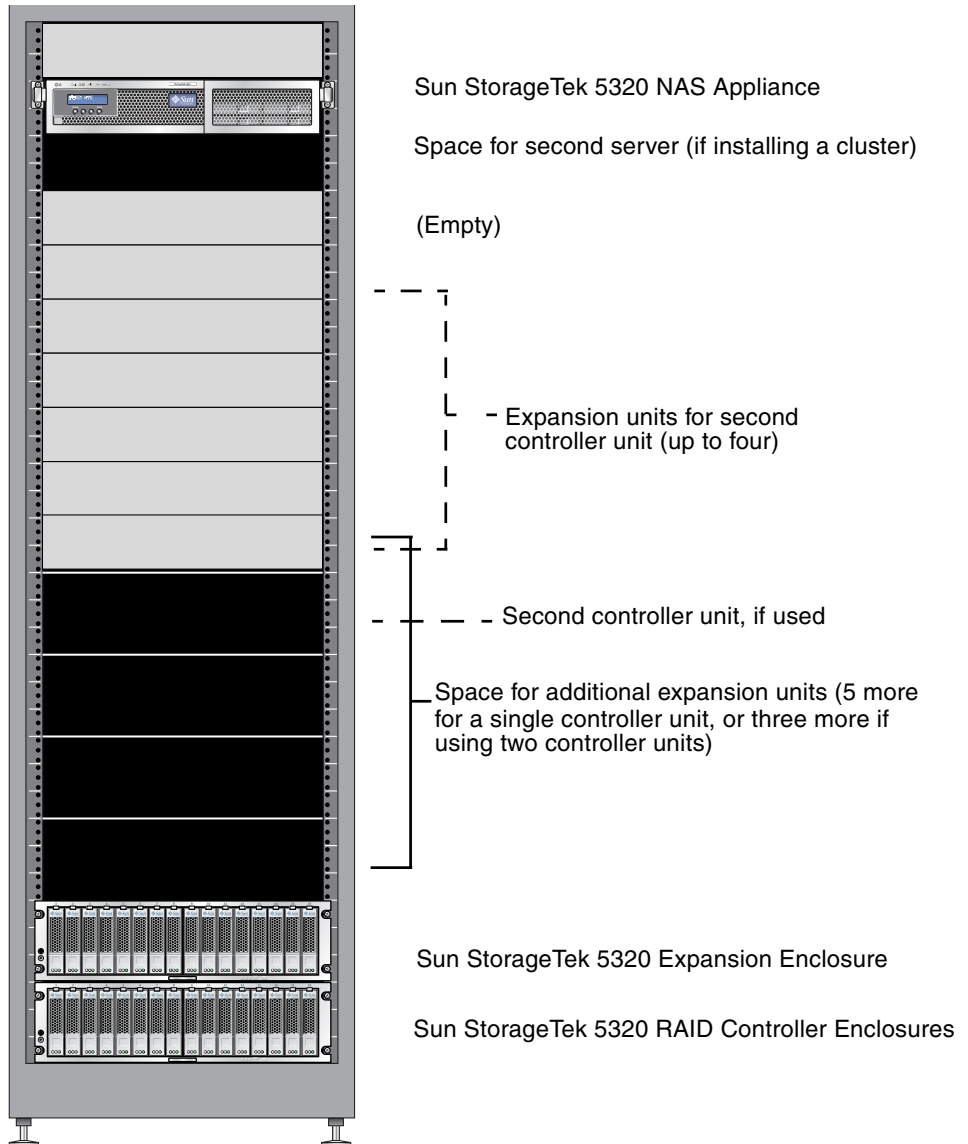

▼ To Install the System With a Single Controller Unit

1. **Mount the controller enclosure in the bottom of the cabinet.**
2. **Mount any expansion unit (maximum six) from the bottom up.**
The first expansion unit above the controller unit is EU 1, then EU 2, and so on.
3. **Mount the Sun StorageTek 5320 NAS Appliance 2 U from the top of the cabinet.**

If you are installing a cluster, install the servers as follows:

- a. **Sun StorageTek 5320 NAS Appliance H1 (software serial number ending “-H1”) at the top.**
The software serial number is located at the front of the server, below the LCD display. It is also printed on the Customer Information Sheet (CIS).
- b. **Sun StorageTek 5320 NAS Appliance H2 (software serial number ending “-H2”) below server H1.**

▼ To Install the System With Two Controller Units

1. **Mount the controller unit in the bottom of the cabinet.**
2. **Mount any expansion units (maximum four) from the bottom up, and be sure to leave space for the maximum four EUs if you do not install them at this time.**
The first expansion unit above the controller unit is EU 1, then EU 2, and so on.
3. **Mount the second controller unit.**
4. **Mount any expansion units (maximum four) for the second controller unit, and be sure to leave space for the maximum four expansion units if you do not install them at this time.**
5. **Mount the Sun StorageTek 5320 NAS Appliance 2 U from the top of the cabinet.**

If you are installing a cluster, install the servers as follows:

- a. **Sun StorageTek 5320 NAS Appliance H1 (software serial number ending “-H1”) at the top.**
The software serial number is located at the front of the server, below the LCD display. It is also printed on the Customer Information Sheet (CIS).
- b. **Sun StorageTek 5320 NAS Appliance H2 (software serial number ending “-H2”) below server H1.**

Attaching the Universal Rail Kit to a Cabinet

This procedure describes the steps to attach the universal rail kit to all standard Sun cabinets, including the Sun Rack 900/1000 cabinets.

▼ To Attach the Universal Rail Kit to a Cabinet

1. **Position the front of the left rail behind the left front cabinet rail (FIGURE 2-2).**

FIGURE 2-2 Positioning the Front of the Left Rail Behind the Left Front Cabinet Rail

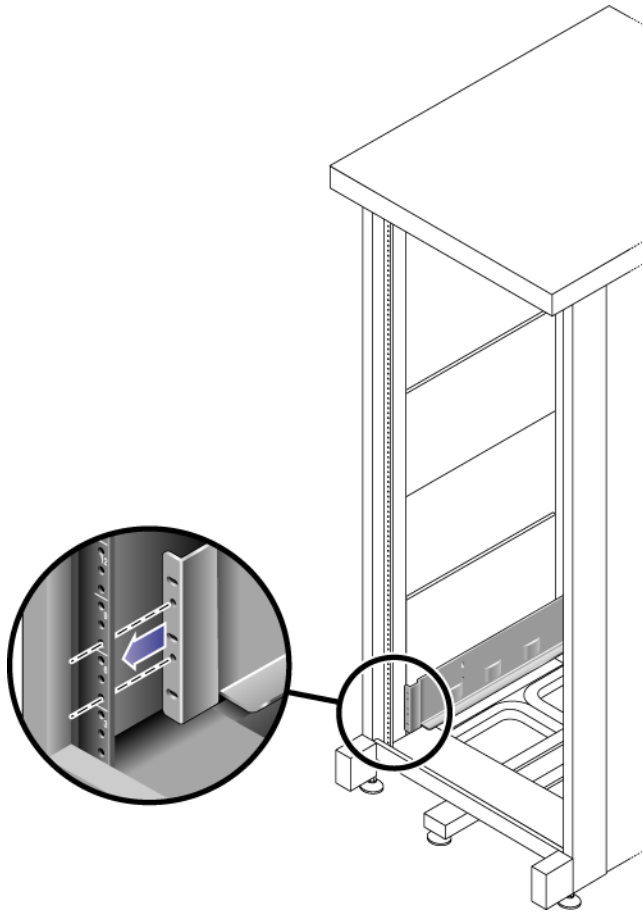

2. Use the No. 2 Phillips screwdriver to insert and tighten two 8-32 screws to secure the left rail to the front of the cabinet (FIGURE 2-3).

Each array requires three standard mounting units (3RU) of vertical space in the cabinet. Each standard mounting unit (U) has three mounting holes in the left and right cabinet rails. Insert the screws into the lowest holes in the top two mounting units of the 3RU slot in which the tray is to be mounted.

These screws pass through the cabinet rail holes and screw into threaded holes in the left rail.

FIGURE 2-3 Securing the Left Rail to the Front of the Cabinet

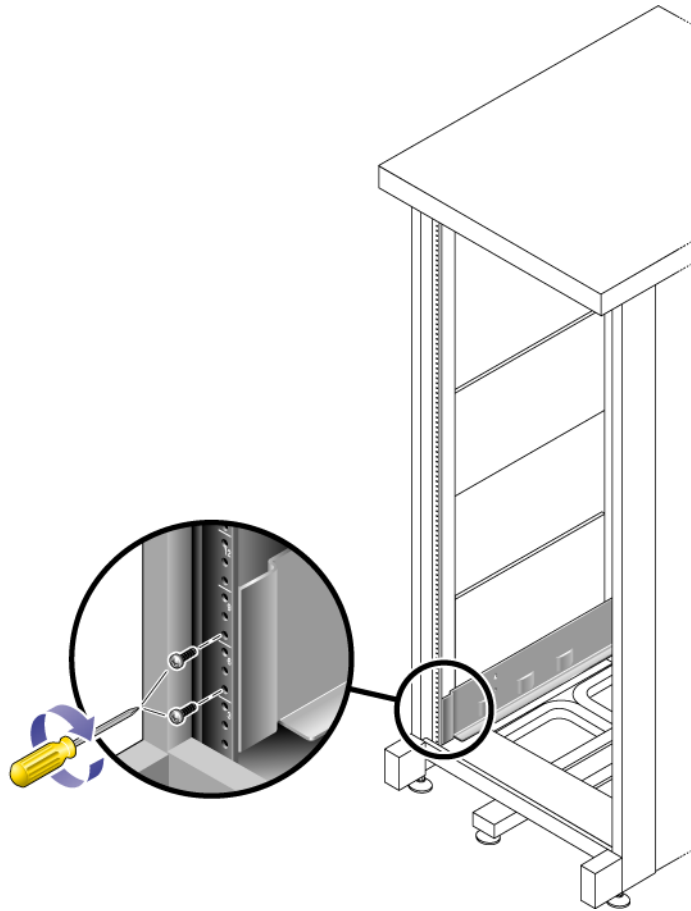

3. Repeat [Step 1](#) and [Step 2](#) for the right rail.
4. At the back of the cabinet, adjust the length of the left rail as needed to fit the cabinet, and position the rail flange over the face of the cabinet rail ([FIGURE 2-4](#)).

FIGURE 2-4 Adjusting the Length of the Left Rail at the Back of the Cabinet

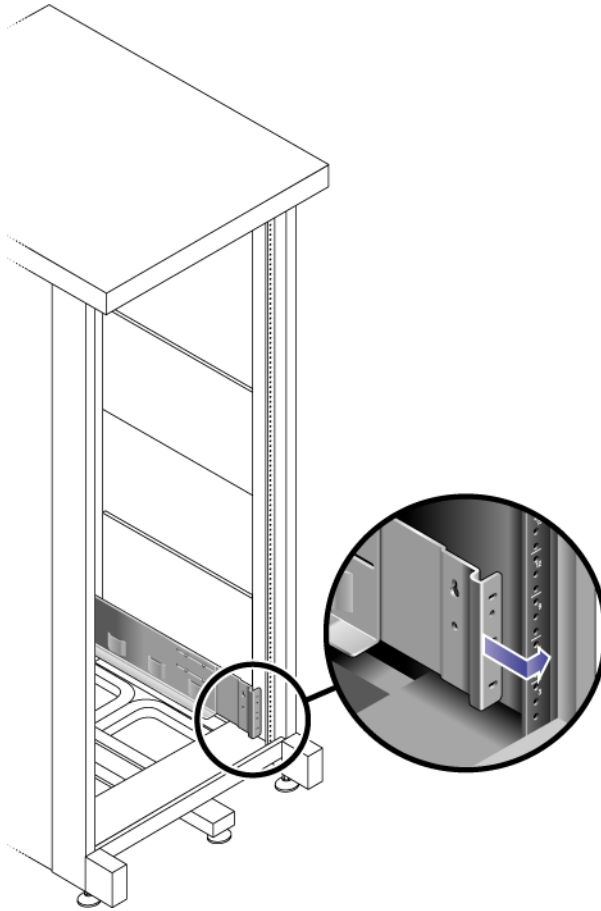

5. Align the rail flange so that the mounting holes correspond to those at the front of the cabinet.

6. Use the No. 3 Phillips screwdriver to insert and tighten four metric M6 screws (two per side) at the back of the rail (FIGURE 2-5).

FIGURE 2-5 Securing the Left Rail to the Back of the Cabinet

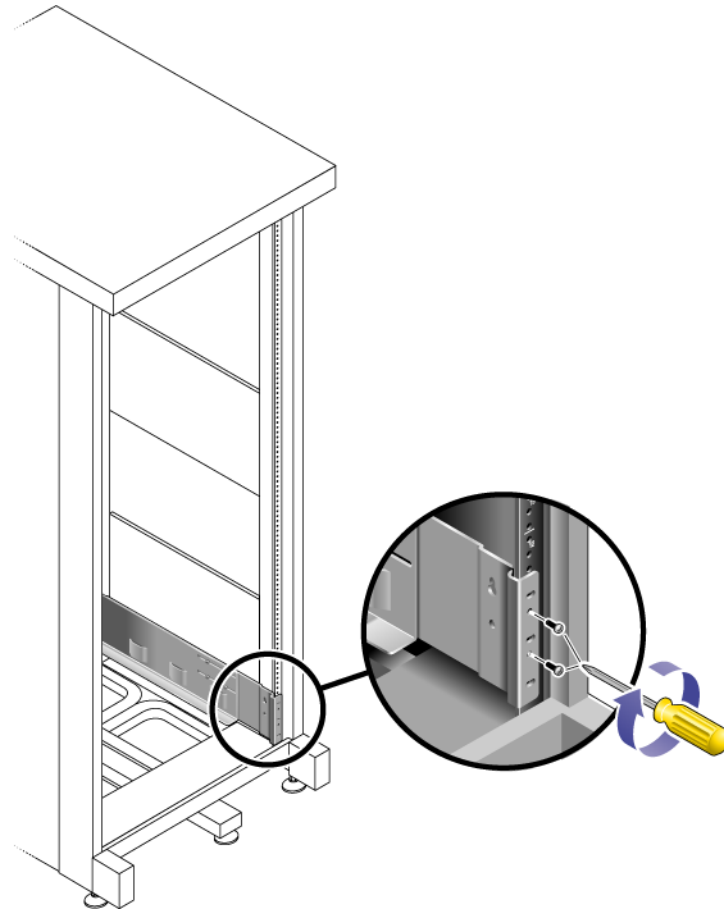

7. Repeat Step 4, Step 5, and Step 6 for the right rail.
8. Using the No. 2 Phillips screwdriver, tighten the eight adjustment screws (four on each side) toward the back of each rail (FIGURE 2-6).

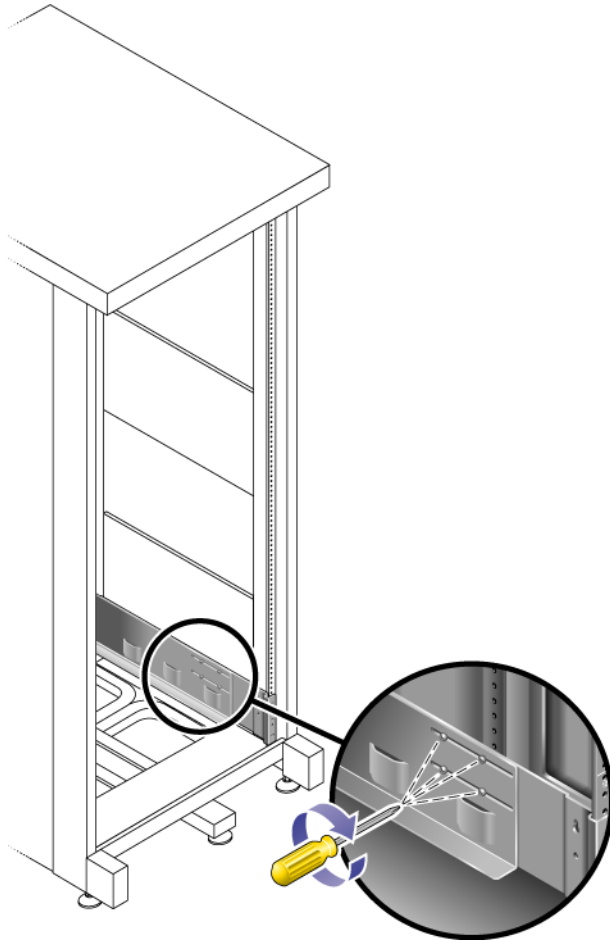

FIGURE 2-6



Installing a Unit in a Cabinet

Install the controller unit in the first empty 3RU slot at the bottom of the cabinet. If you are installing expansion units, continue installing the units from the bottom up.

1. Using two people, one at each side of the unit, carefully lift and rest the unit on the bottom ledge of the left and right rails (FIGURE 2-7).



Caution – Use care to avoid injury. A unit can weigh up to 95 pounds (45 kg).

FIGURE 2-7 Positioning the Unit in the Cabinet

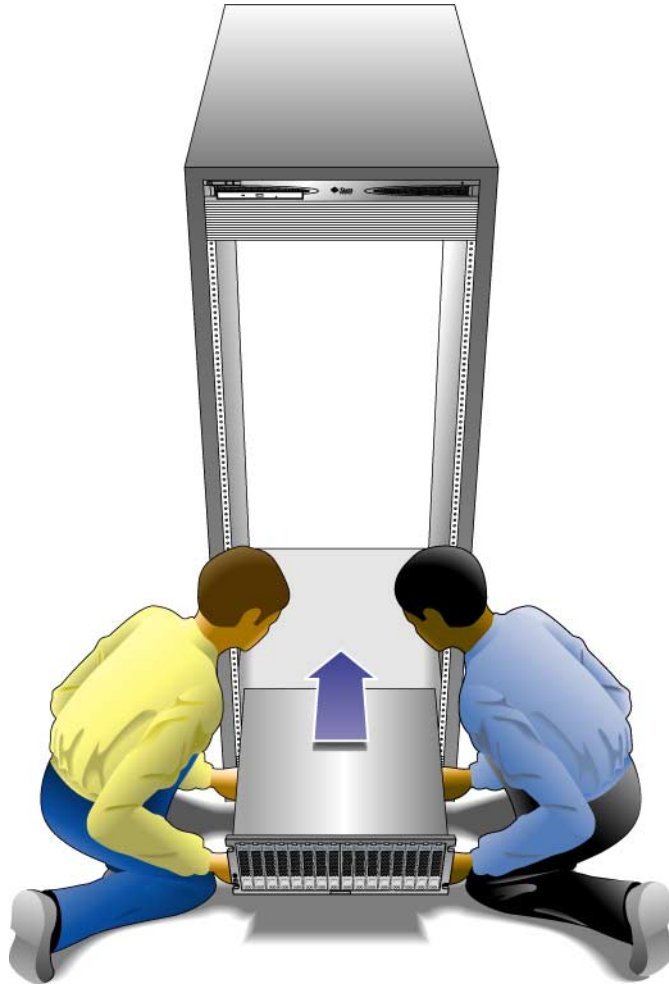

2. Carefully slide the unit into the cabinet until the front flanges of the unit touch the vertical face of the cabinet (FIGURE 2-8).

FIGURE 2-8 Sliding the Unit Into the Cabinet

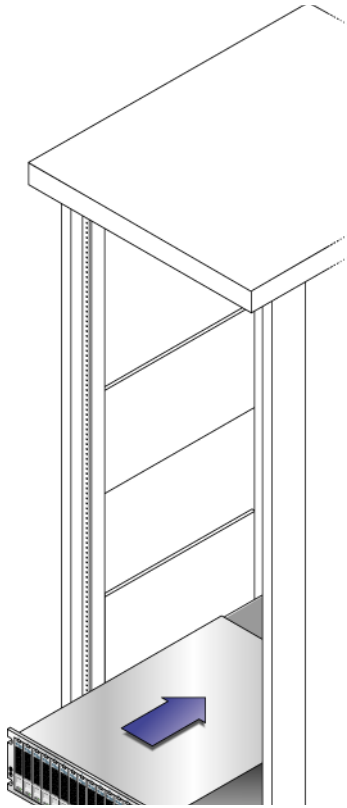

3. Use the No. 3 Phillips screwdriver to install and tighten four M6 screws (two per side) to secure the tray to the front of the cabinet ([FIGURE 2-9](#)).

FIGURE 2-9 Securing the Unit to the Front of a Sun Rack 900/1000 Cabinet

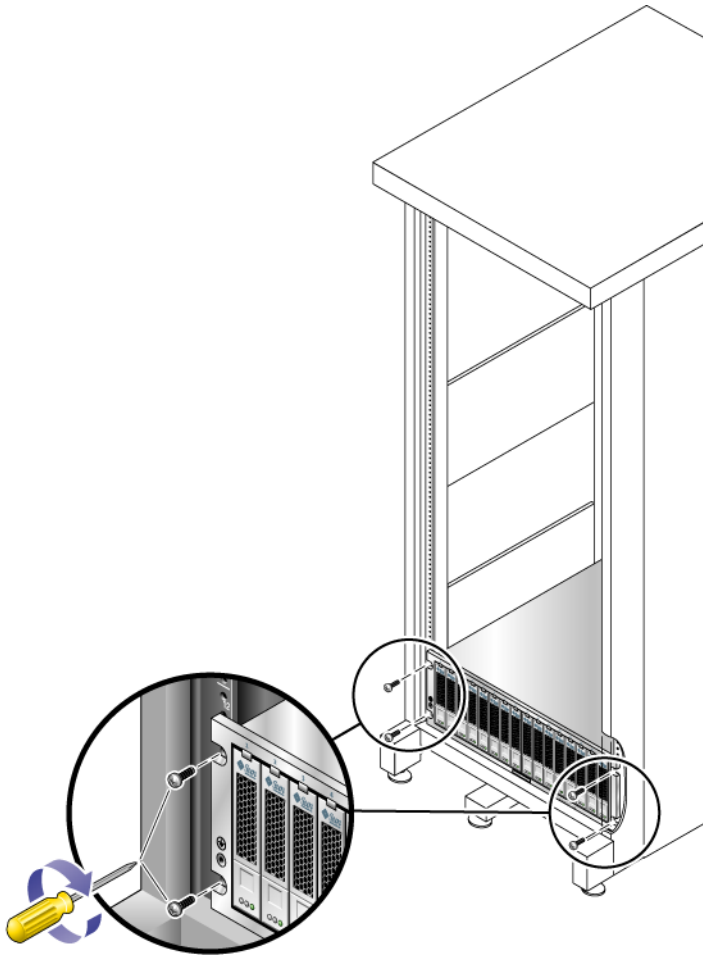

4. Install and tighten two 6-32 screws (one per side) at the back of the tray, to secure the back of the tray to the cabinet (FIGURE 2-10).

Note – The two upper holes on the back of the tray are not used.

FIGURE 2-10 Securing the Unit to the Back of the Cabinet Rail

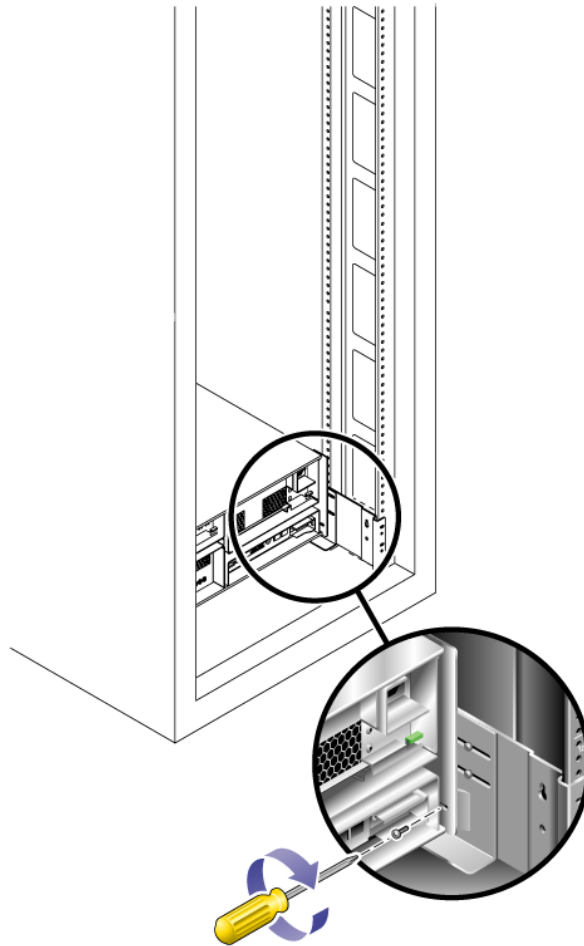

Installing a Server in a Cabinet

Installing a server involves three steps:

1. Installing the slide rails (refer to [“To Install the Slide Rail Assemblies”](#) on page 34)
2. Installing the cable management kit (refer to [“To Install the Cable Management Kit”](#) on page 42)

3. Verifying the operation of the slide rails and cable management (refer to [“To Verify the Operation of the Slide Rails and the CMA”](#) on page 46)

▼ To Install the Slide Rail Assemblies

1. Pull both mounting brackets completely out of their respective slide rails:
 - a. Simultaneously press and hold the upper and lower lock buttons of the slide rail lock ([FIGURE 2-11](#)).

FIGURE 2-11 Unlocking the Slide Rail Assembly

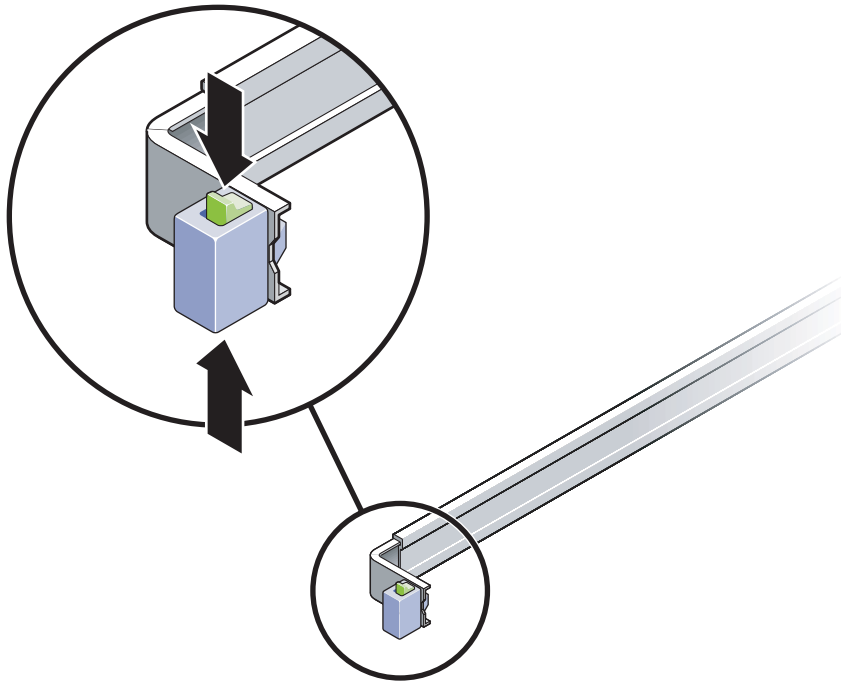

- b. Pull the mounting bracket out until it locks in the extended position.

- c. Slide the mounting bracket release button in the direction shown in [FIGURE 2-12](#), and then slide the mounting bracket out of the slide rail.

FIGURE 2-12 Location of the Mounting Bracket Release Button

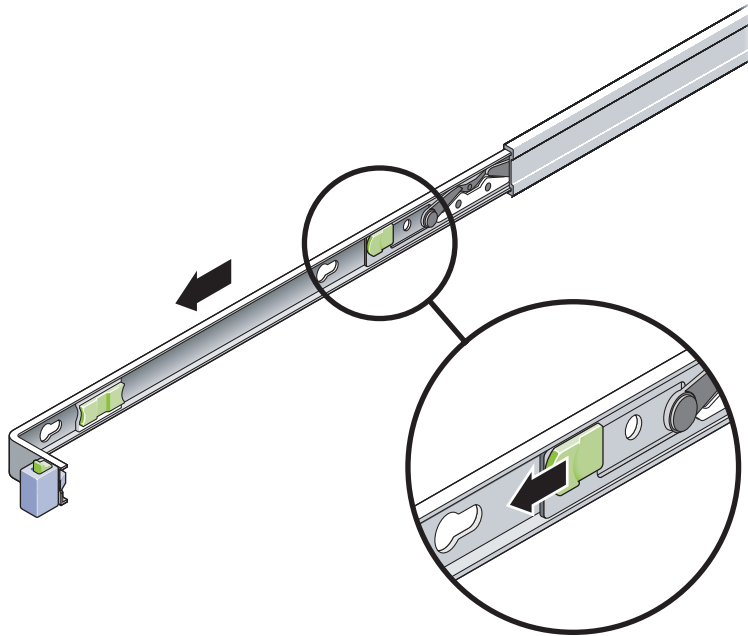

- d. Press the metal lever (labeled Push) on the middle section (FIGURE 2-13) of the sliding rail, and then push the middle section back into the rack.

FIGURE 2-13 Unlocking the Slide Rail Middle Section

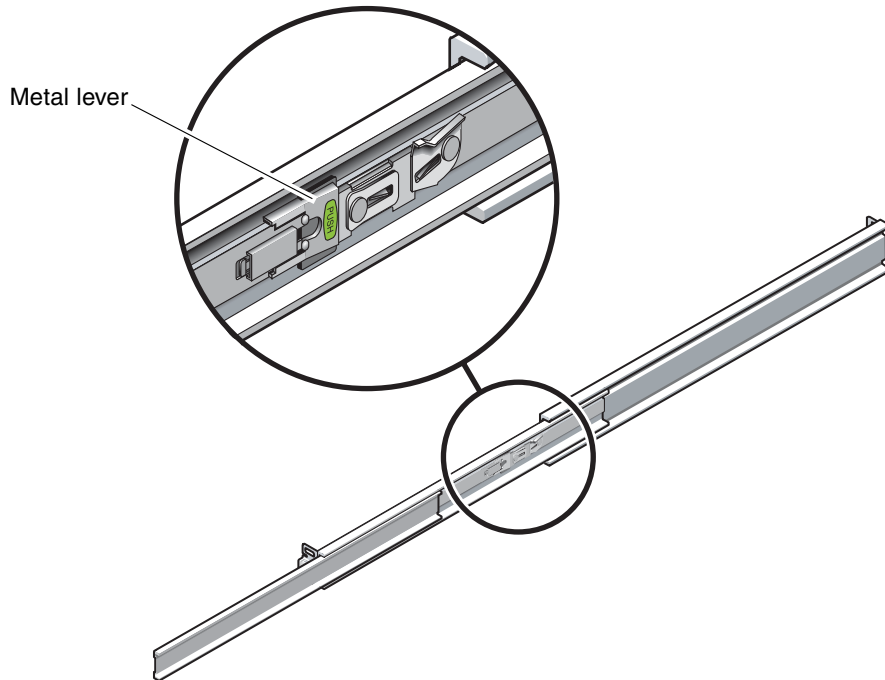

2. Attach a mounting bracket to the right side of the server chassis.

- a. Position the mounting bracket against the server chassis (FIGURE 2-14) so that the slide rail lock is at the front and the three keyed openings on the mounting bracket are aligned with the three locating pins on the side of the chassis.

FIGURE 2-14 Attaching a Mounting Bracket to the Chassis

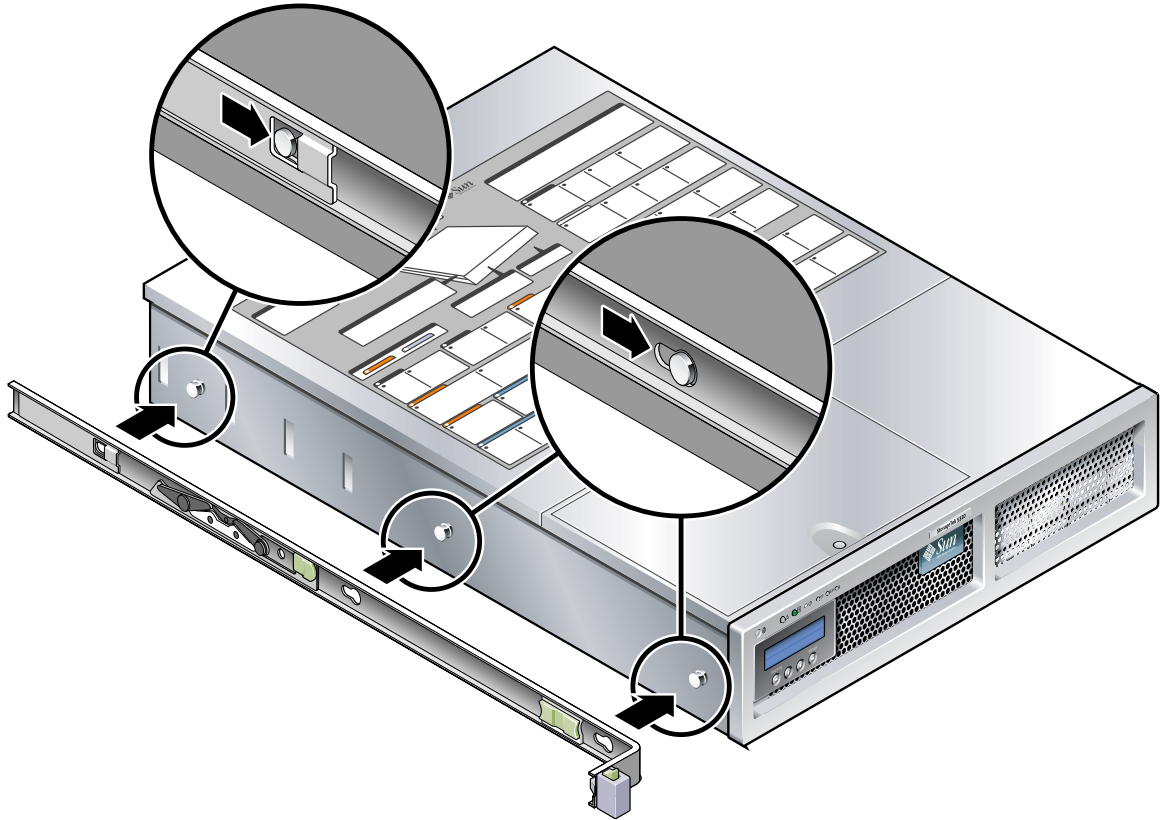

- b. With the heads of the three locating pins protruding through the three keyed openings in the mounting bracket, pull the mounting bracket toward the front of the chassis until the bracket locks into place with an audible click.
 - c. Verify that all three locating pins are trapped in the keyed openings and that the back locating pin has engaged the mounting bracket lock, as shown in the right side of FIGURE 2-14.
3. Attach the second mounting bracket to the left side of the server chassis.

4. Determine which rack hole numbers to use when attaching the slide rails to the rack posts.

The server is two rack units tall (2U). The slide rails will occupy the lower half of the 2U space.

5. Determine which screws you will use to mount the slide rails.

If your rack has threaded mounting holes in the rack posts, determine whether the threads are metric or standard. Select the appropriate screws from the package included in the mounting kit.

If your rack does not have threaded mounting holes, the mounting screws are secured with a caged nut.

6. Attach a slide rail to the right front rack post.

- a. Loosely attach the front of a slide rail to the right front rack post ([FIGURE 2-15](#)) using two screws.

Note – Do not tighten the screws yet.

FIGURE 2-16 Using the Slide Rail Spacing Tool to Adjust the Distance Between the Slide Rails

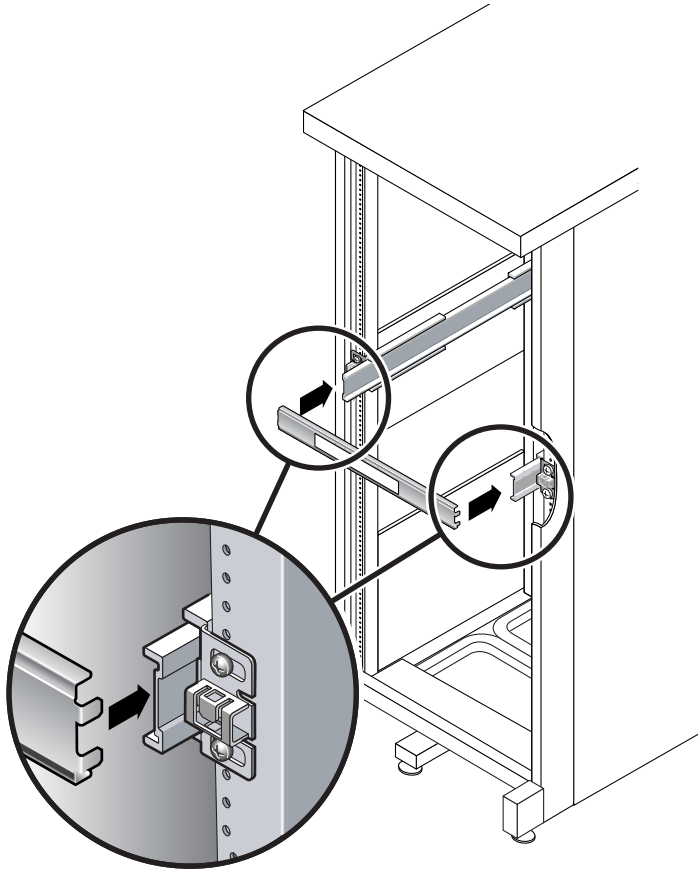

- b. Insert the right side of the tool into the front end of the right rail, while sliding the end of the rail to the right or left as needed to allow the ends of the tool to enter the ends of both rails.**

The distance between the rails is now equal to the width of the server with mounting brackets.

- c. Tighten the screws to lock the ends of the rails in place.**
- d. At the back of the rack, repeat [Step a](#) through [Step c](#) for the back ends of the rails.**

- 9. Deploy the anti-tilt bar, if the chassis or rack is so equipped.**



Caution – The weight of the server on extended slide rails can be enough to overturn a cabinet.

10. Insert the ends of the mounting brackets into the sliding rails (FIGURE 2-17).



Caution – The server weighs approximately 52 pounds (24 kg). Two people are required to lift and mount the system into a rack enclosure when using the procedures in this chapter.

FIGURE 2-17 Mounting the Chassis on the Slide Rails

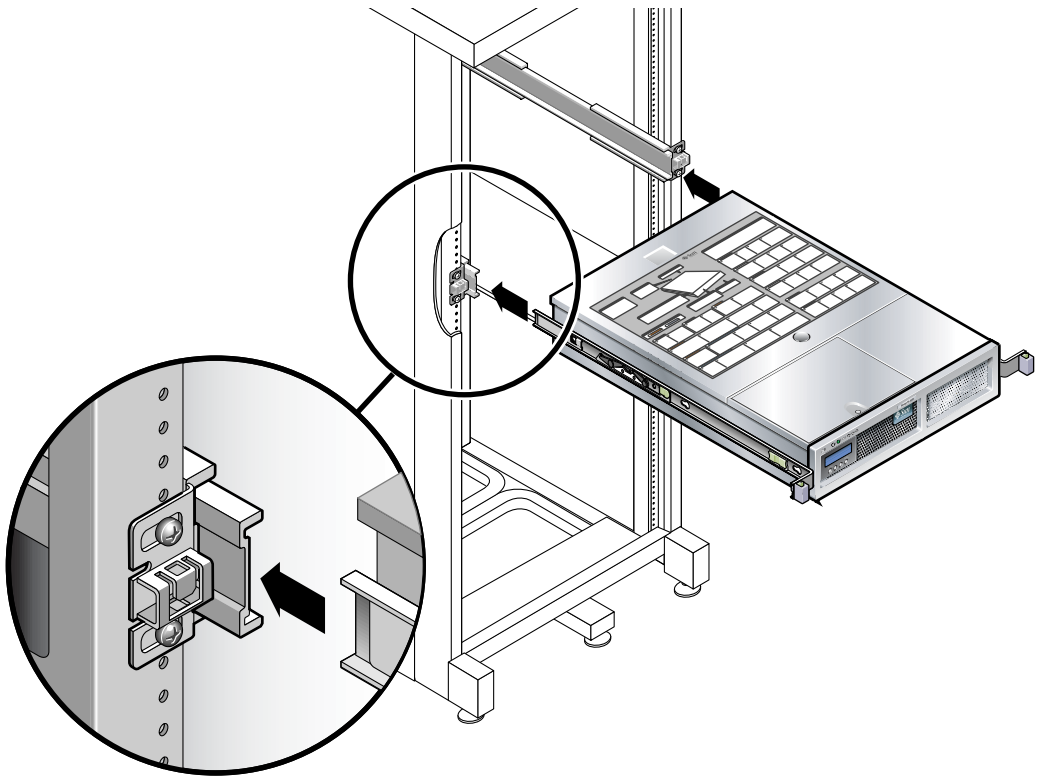

11. Simultaneously release the rail locks on each side of the sliding rails, and guide the chassis into the rack.



Caution – Verify that the server is securely mounted in the rack, and that the slide rails are locked to the mounting brackets, before continuing.

▼ To Install the Cable Management Kit

The cable management assembly (CMA) clips into the ends of the left and right sliding rail assemblies. No screws are necessary for mounting the CMA.



Caution – Support the CMA during this installation. Do not allow the assembly to hang by its own weight until it is secured by all three attachment points.

1. **At the back of the rack, plug the CMA rail extension into the end of the left sliding rail assembly (FIGURE 2-18).**

The tab at the front of the rail extension clicks into place.

FIGURE 2-18 Inserting the CMA Rail Extension Into the Back of the Left Slide Rail

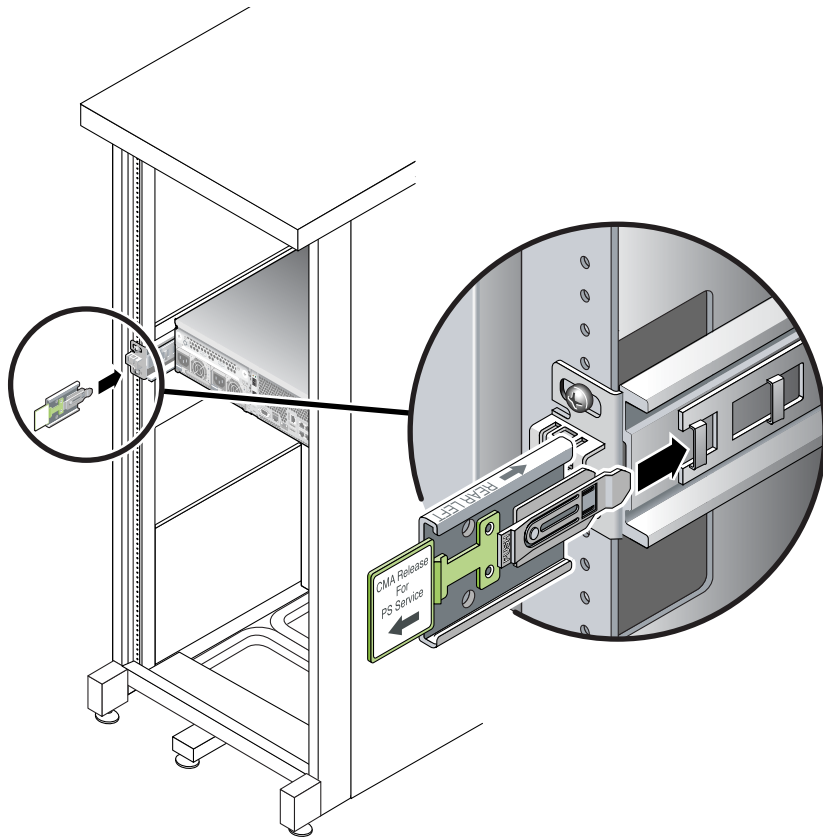

The right sides of the two CMA arms have hinged extensions. On the manufacturer's instruction sheet, the smaller extension is called the CMA Connector for Inner Member. It attaches to the right mounting bracket. The larger extension is called the CMA Connector for Outer Member, and attaches to the right sliding rail.

2. Insert the smaller extension into the clip located at the end of the mounting bracket (FIGURE 2-19).

FIGURE 2-19 Mounting the Inner CMA Connector

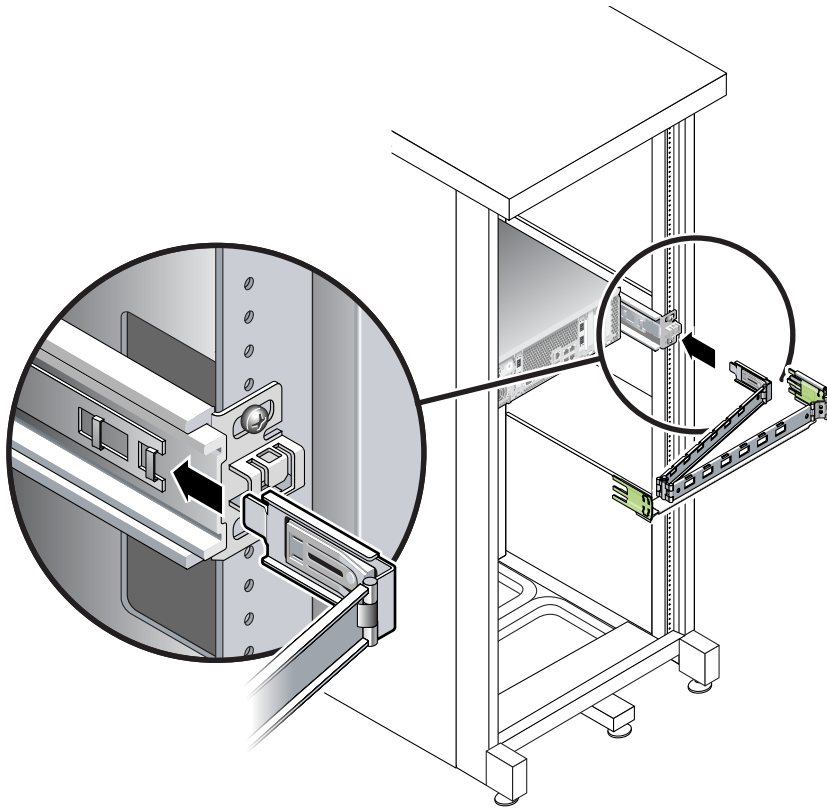

3. Insert the larger extension into the end of the right sliding rail (FIGURE 2-20).

FIGURE 2-20 Attaching the Outer CMA Connector

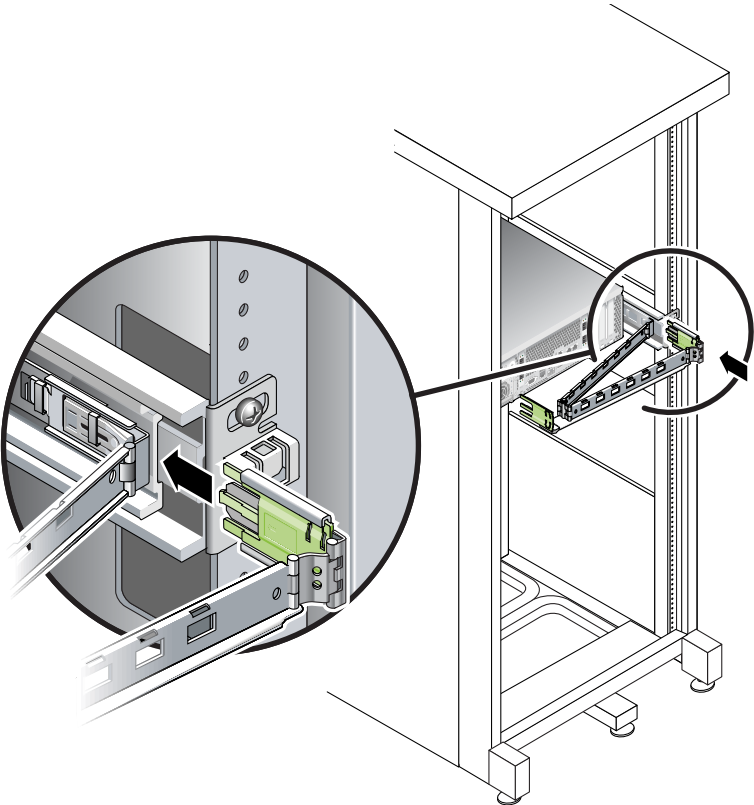

4. Insert the hinged plastic connector at the left side of the CMA fully into the CMA rail extension (FIGURE 2-21).

The plastic tab on the CMA rail extension locks the hinged plastic connector in place.

FIGURE 2-21 Mounting the Left Side of the Slide Rail

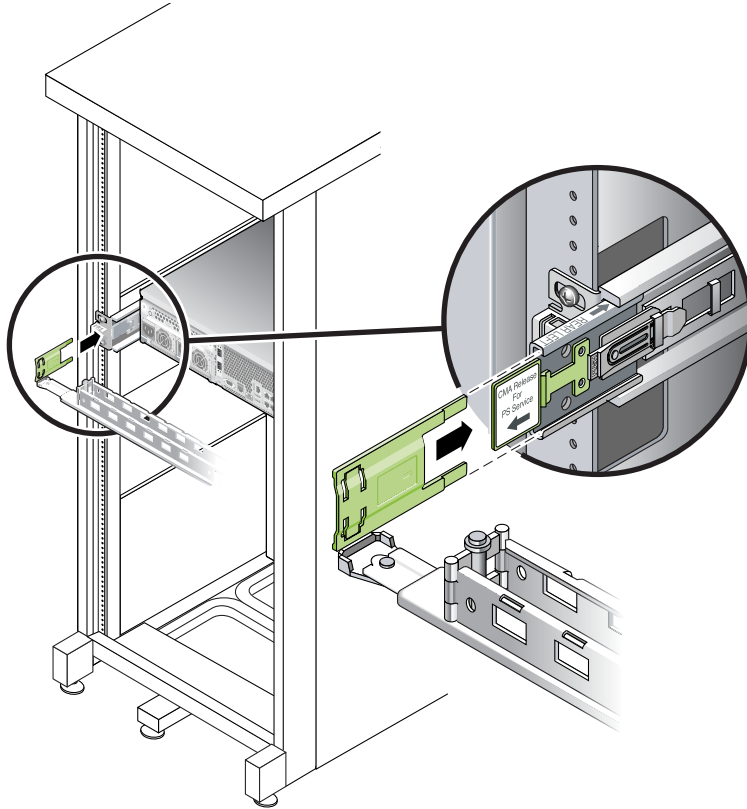

▼ To Verify the Operation of the Slide Rails and the CMA

Tip – Two people are needed for this procedure: one to move the server in and out of the rack and one to observe the cables and CMA.

1. For a cabinet or a free-standing rack, deploy the anti-tilt bar.

2. Unlock the slide lock buttons (FIGURE 2-22) at the right and left sides of the server chassis, and slowly pull the server out of the rack until the slide rails reach their stops.

FIGURE 2-22 Unlocking the Slide Rail Assembly

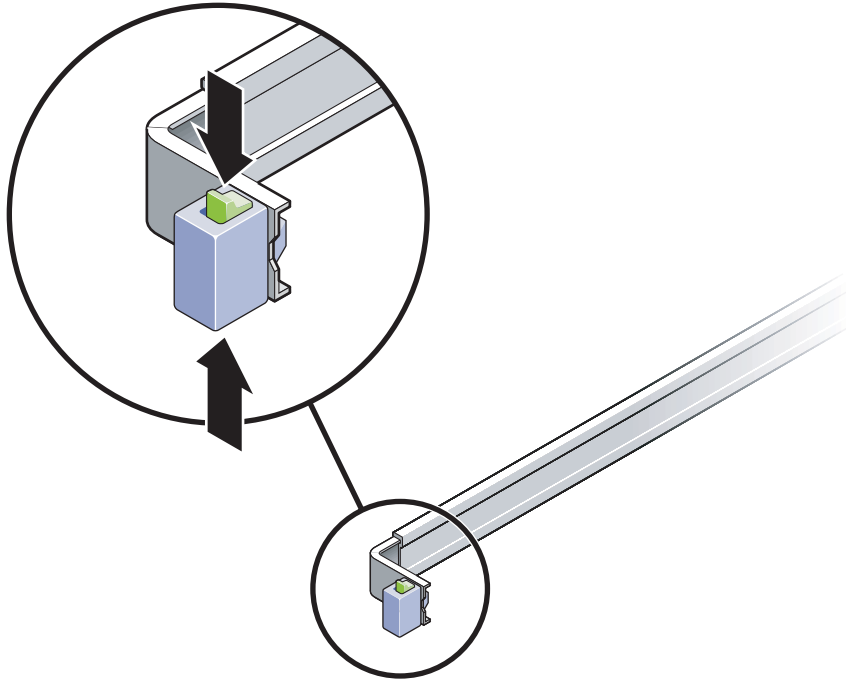

3. Inspect the attached cables for any binding or kinks.
4. Verify that the CMA extends fully and does not bind in the slide rails.

5. When the server is fully extended out, release the slide rail lever stops (FIGURE 2-23).

Push both levers simultaneously and slide the server back into the rack.

FIGURE 2-23 Unlocking the Slide Rail Lever Stops

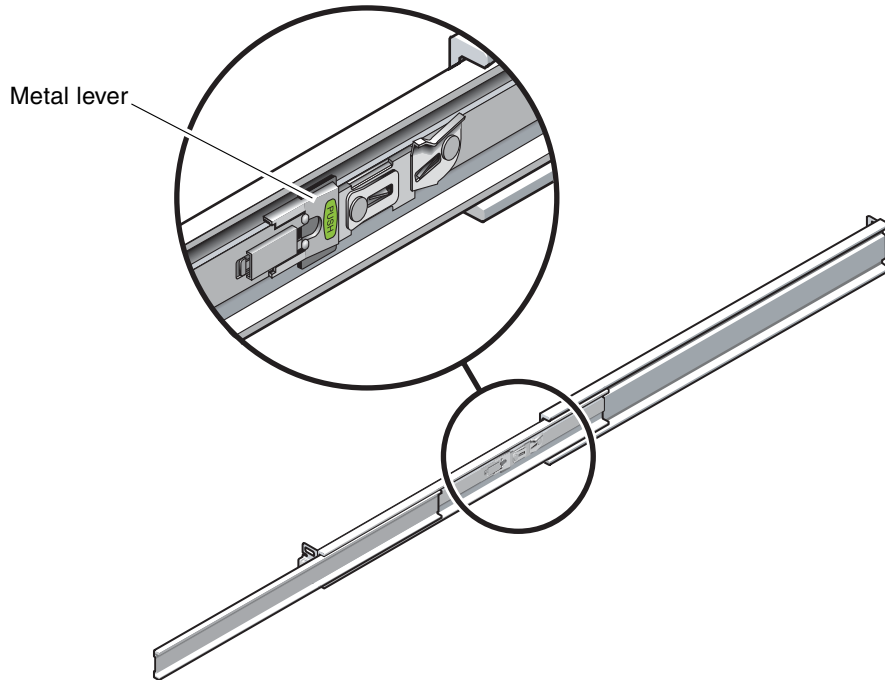

6. Simultaneously unlock both slide rail release buttons (FIGURE 2-24), and push the server completely into the rack.

FIGURE 2-24 Slide Rail Release Button

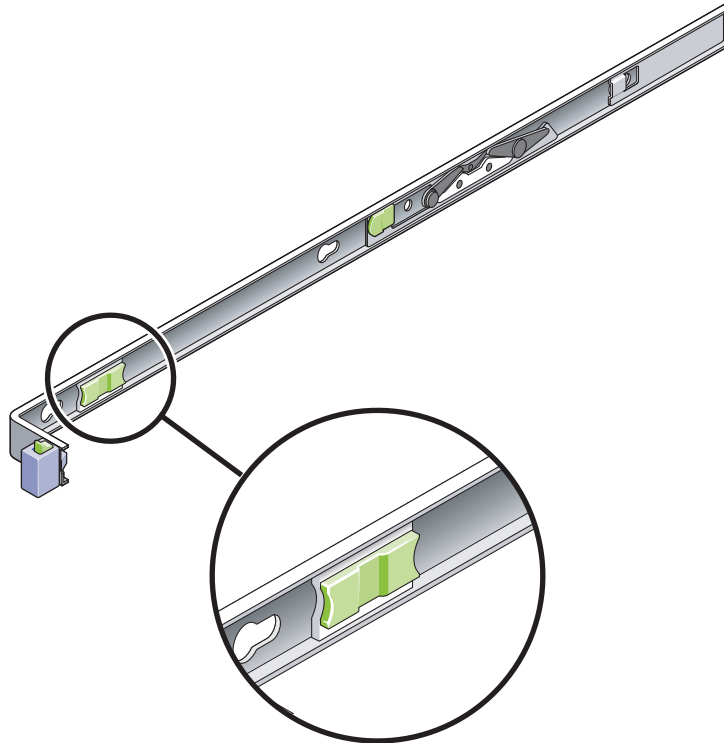

The server should stop after approximately 15 inches (40 cm) of travel.

7. Verify that the cables and the CMA retracted without binding.
8. Adjust the cable hangers and CMA as required.

Upgrading a Sun StorageTek 5320 Cabinet

If you have an existing Sun StorageTek 5320 with Sun StorEdge 5300 expansion enclosures and/or controller enclosures and you are adding additional Sun StorageTek 5320 expansion units, you need to use the Universal Rail Kit to add the new components. FIGURE 2-25 shows the cabinet with a single controller enclosure, single expansion unit, room for additional storage, and single server installed at the top.

Connecting the Power Cables

This section describes how to connect the power cables.

Note – Do not power on the units until you complete the installation procedures for your system. The power-on sequence is described in detail in [“Powering On the Sun StorageTek 5320 NAS Appliance, Controller Units, and Expansion Units”](#) on page 74.

▼ To Connect the Power Cables

1. Verify that both power switches are off for each controller unit and expansion unit in the cabinet.
2. Connect each power supply in each unit to a separate power source in the cabinet.



Caution – The cabinet must have two power sources connected to two separate power circuits.

3. Connect each power supply in the Sun StorageTek 5320 NAS Appliance to a separate power source in the cabinet.

After connecting the server power cords to the power source, the Power/OK LED flashes indicating standby power mode.

4. Connect the primary power cables from the cabinet to the external power source.

Back-End Storage Cabling

When you have finished installing all units and servers and connected their power cables, you are ready to connect the servers to the controller units and the controller units to the (optional) expansion units as described in subsequent chapters.

Use the chapter appropriate to the system that you are setting up.

TABLE 2-1

To connect:	Refer to:
Single-server Sun StorageTek 5320 NAS Appliance to back-end storage	Chapter 3
Dual-server Sun StorageTek 5320 NAS Cluster Appliance to back-end storage	Chapter 4
Sun StorageTek 5320 NAS Gateway System to SAN storage	Chapter 5

Connecting the Sun StorageTek 5320 NAS Appliance

This chapter provides comprehensive instructions for connecting the Sun StorageTek 5320 NAS Appliance, the Sun StorEdge 5300 RAID Controller Enclosures, and the optional Sun StorEdge 5300 Expansion Enclosures. It also provides initial configuration instructions for the system.

Note – This chapter contains single-server Sun StorageTek 5320 NAS Appliance connection and configuration instructions only. If you are connecting a different system, refer to the appropriate chapter.

This chapter contains the following sections:

- [“Before You Begin” on page 54](#)
- [“Connecting the Sun StorageTek 5320 NAS Appliance to Back-End Storage” on page 54](#)
- [“Connecting to the Network” on page 73](#)
- [“Powering On the Sun StorageTek 5320 NAS Appliance, Controller Units, and Expansion Units” on page 74](#)
- [“Initial Sun StorageTek 5320 NAS Appliance Configuration” on page 78](#)

Note – The Sun StorageTek 5320 NAS Appliance ships with the operating system installed.

Before You Begin

Before connecting the system, you must install the units in the rack. Refer to [“Installing Servers and Back-End Storage” on page 13](#) for rackmount instructions.

Connecting the Sun StorageTek 5320 NAS Appliance to Back-End Storage

This section describes how to cable the Sun StorageTek 5320 NAS Appliance to backend storage, for several different configurations.

This section includes the following tasks:

- [“Connecting the Sun StorageTek 5320 NAS Appliance to the Controller Unit” on page 54](#)
- [“Connecting Controller Units to Expansion Units” on page 59](#)

Connecting the Sun StorageTek 5320 NAS Appliance to the Controller Unit

FIGURE 3-1 Sun StorageTek 5320 NAS Appliance HBA Cards and Controller Unit Ports

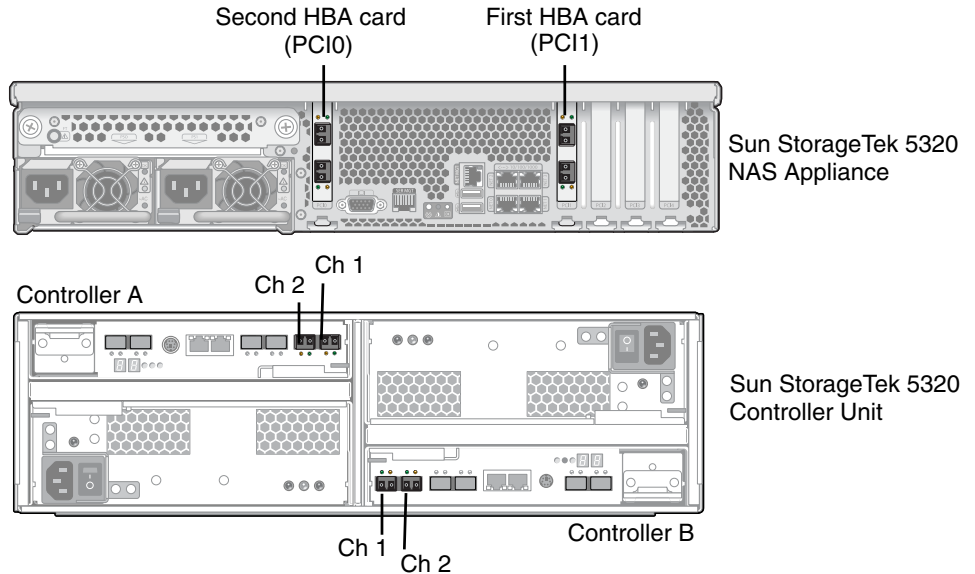

Note – HBA cards for storage connections are inserted only in PCI slot 1 (PCI1) and, optionally, PCI slot 0 (PCI0) of the Sun StorageTek 5320 NAS Appliance.

This section contains details on the following:

- [“To Connect One Controller Unit”](#) on page 56
- [“To Connect One Controller Unit to Two HBA Cards”](#) on page 57
- [“To Connect Two Controller Units”](#) on page 57

▼ To Connect One Controller Unit

Use the instructions in this section if you are connecting one controller unit to the Sun StorageTek 5320 NAS Appliance.

For a Sun StorageTek 5320 NAS Appliance with one dual port FC HBA card in PCI slot 1 (FIGURE 3-2):

1. Connect the HBA port 1 (top port) on the Sun StorageTek 5320 NAS Appliance to the Controller A Ch 1 port.
2. Connect the HBA port 2 (bottom port) on the Sun StorageTek 5320 NAS Appliance to the Controller B Ch 1 port.

Note – The Ch 2 ports on controller A and controller B remain empty.

FIGURE 3-2 Connecting the Sun StorageTek 5320 NAS Appliance to the Controller Unit

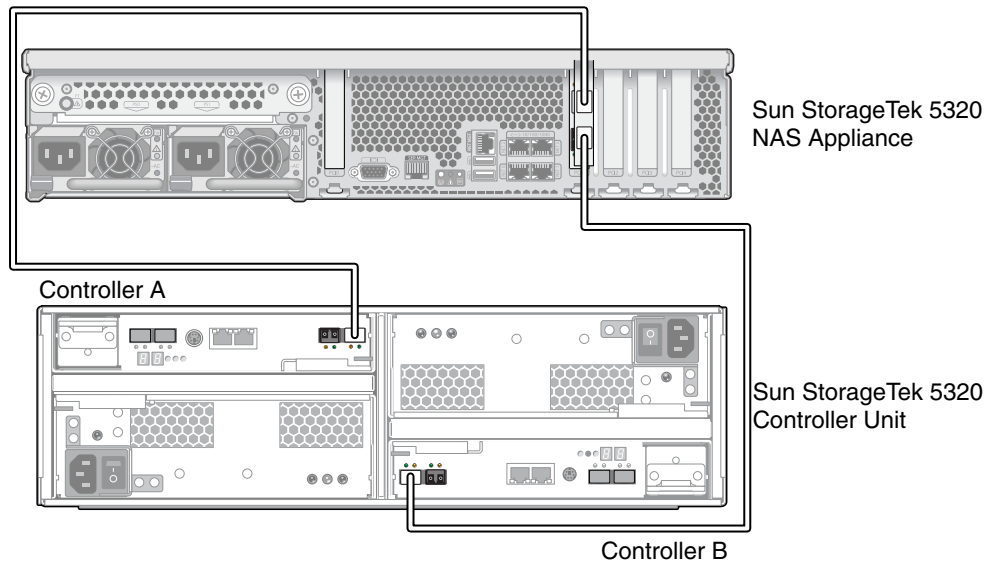

Note – The preceding figure is for illustrative purposes only. The units have more space between them when they are installed in a cabinet.

▼ To Connect One Controller Unit to Two HBA Cards

Use the instructions in this section if you are connecting a Sun StorageTek 5320 NAS Appliance with two dual port FC HBA cards in PCI slots 1 and 0.

1. Connect the HBA port 1 (top port) of the first HBA card (PCI1) to the Controller A Ch 1 port.
2. Connect the HBA port 1 (top port) of the second HBA card (PCI0) to the Controller B Ch 1 port.

FIGURE 3-3 Connecting Two HBA Cards to the Controller Unit

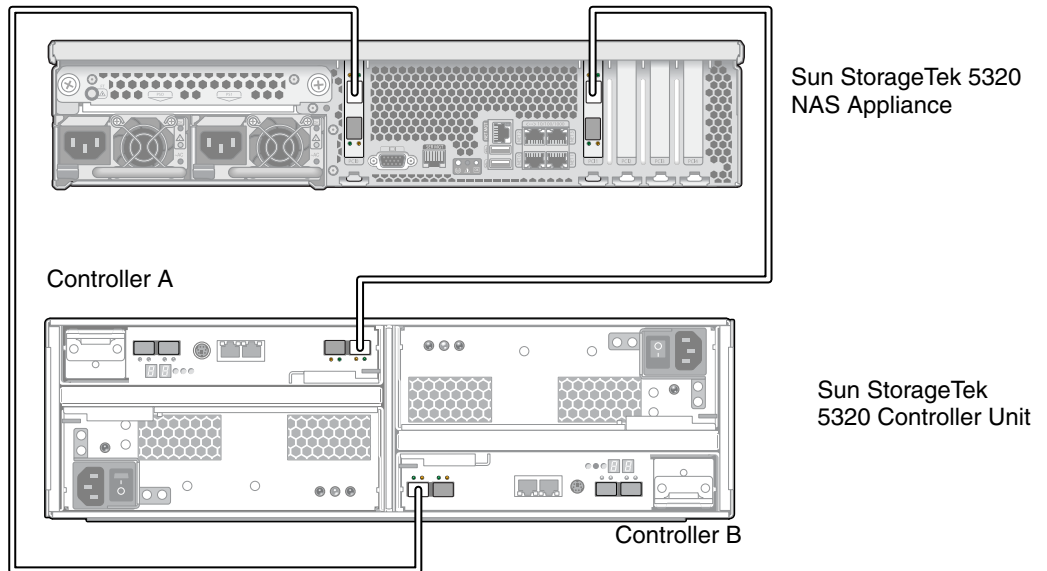

Note – The preceding figure is for illustrative purposes only. The units have more space between them when they are installed in a cabinet.

▼ To Connect Two Controller Units

Use the instructions in this section if you are connecting two controller units to the Sun StorageTek 5320 NAS Appliance.

Note – The Sun StorageTek 5320 NAS Appliance must have two HBA cards (one in PCI slot 1 and one in PCI slot 0) to connect to two controller units.

1. Connect the HBA port 1 (top port) of the first HBA card (PCI1) to the Controller A Ch 1 port on the first (bottom) controller unit (Unit 1).

2. Connect the HBA port 1 of the second HBA card (PCI0) to the Controller B Ch 1 port on Unit 1.
3. Connect the HBA port 2 of the first HBA card to the Controller B Ch 1 port on the second (top) controller unit (Unit 2).
4. Connect the HBA port 2 of the second HBA card to the Controller A Ch 1 port on Unit 2.

FIGURE 3-4 Connecting the Sun StorageTek 5320 NAS Appliance to Two Controller Units

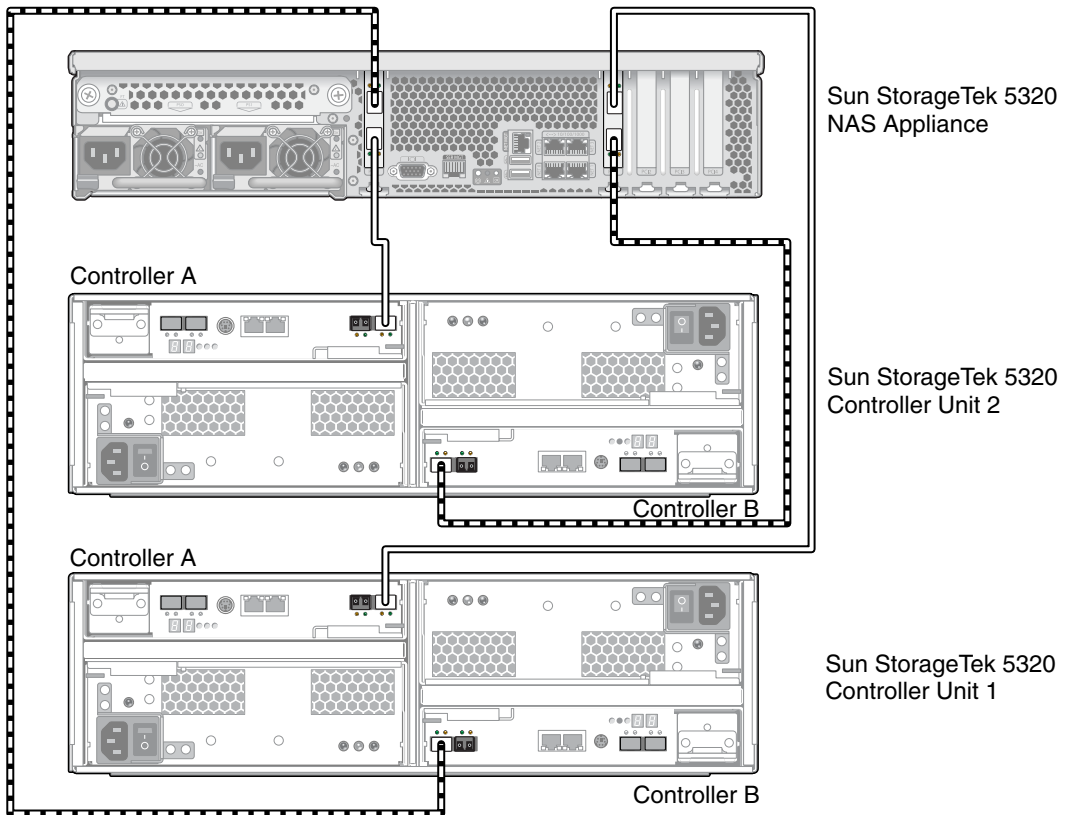

Note – The preceding figure is for illustrative purposes only. The units have more space between them when they are installed in a cabinet.

Connecting Controller Units to Expansion Units

A controller unit uses Controller A and Controller B expansion ports (P1 and P2) to connect to FC-AL ports (1A and 1B) at the back of an expansion unit. Refer to [FIGURE 3-5](#) for port locations.

FIGURE 3-5 Controller Unit and Expansion Unit Ports

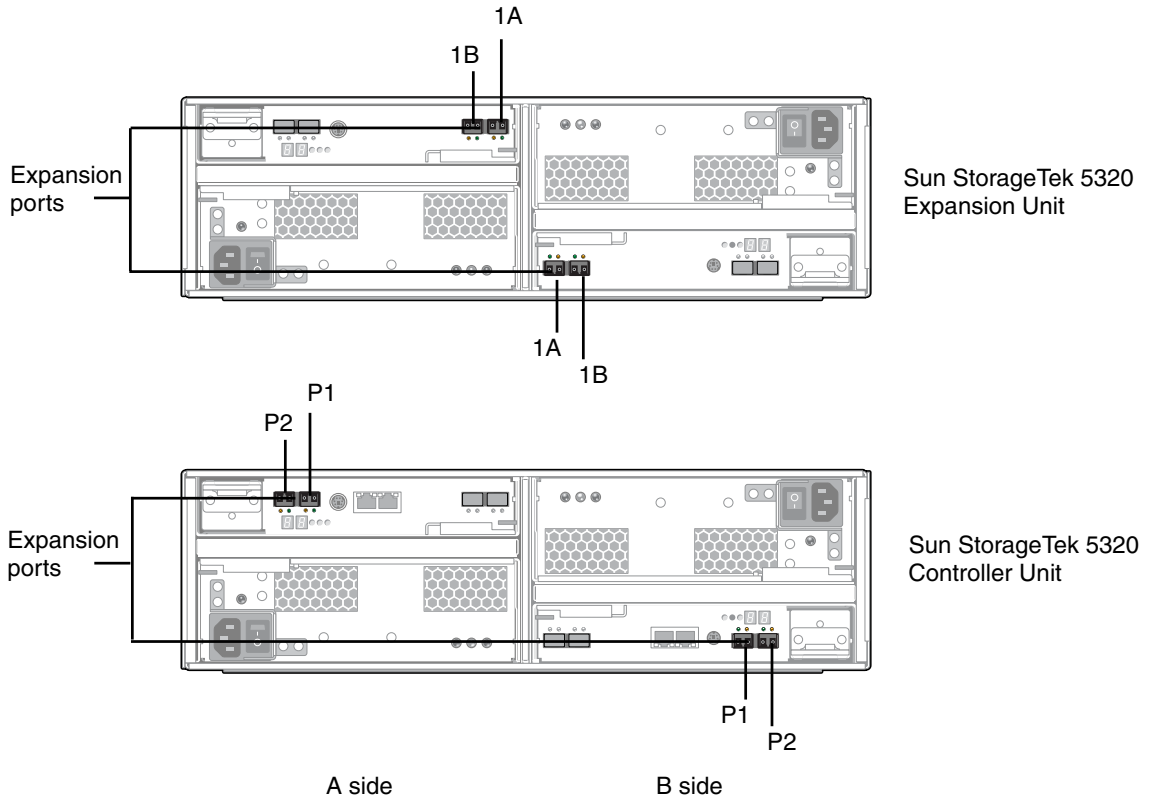

Note – The controller units and the expansion units connect with a pair of optical fiber cables. Optical SFP transceivers have been installed in the controller units' host ports to interface with the optical fiber cable's LC connectors.

Note – This section contains instructions for connecting controller units and expansion units. These instructions apply to one controller unit or to two controller units. If you are using two controller units, follow the same instructions to connect expansion units to *each* controller unit.

A maximum of six expansion units can be attached to each controller unit. The cabling differs depending on the number of expansion units you are connecting:

- For one expansion unit, refer to [“To Cable a Controller Unit to One Expansion Unit” on page 60](#).
- For two expansion units, refer to [“To Cable a Controller Unit to Two Expansion Units” on page 61](#).
- For three expansion units, refer to [“To Cable a Controller Unit to Three Expansion Units” on page 62](#).
- For four to six expansion units, refer to [“To Cable a Controller Unit to Six Expansion Units” on page 65](#).

▼ To Cable a Controller Unit to One Expansion Unit

To connect a controller unit and one expansion unit, two 2-meter fiber cables are required. Refer to [FIGURE 3-6](#).

1. **Connect one cable between the A side expansion port P1 of the controller unit and the A side port 1B of the expansion unit.**
2. **Connect one fiber cable between the B side expansion port P1 of the controller unit and the B side port 1B of the expansion unit.**

Note – The other drive ports in the units remain empty.

FIGURE 3-6 Controller Unit and One Expansion Unit Cable Interconnection

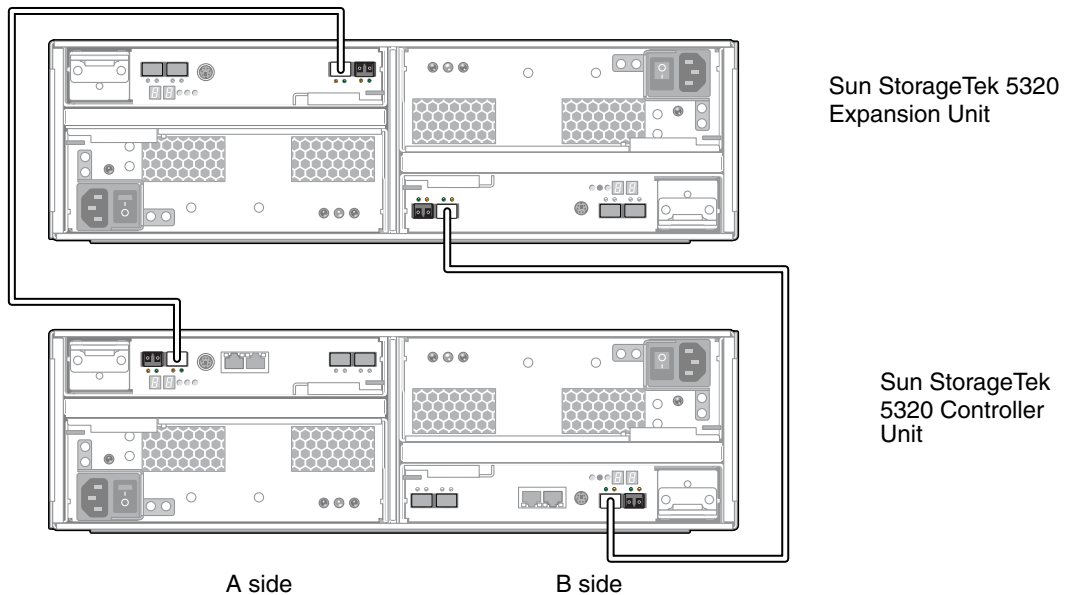

▼ To Cable a Controller Unit to Two Expansion Units

To connect a controller unit and two expansion units, four 2-meter fiber cables are required. Refer to [FIGURE 3-7](#).

1. Connect one fiber cable between the A side expansion port P1 of the controller unit and the A side port 1B of expansion unit 1.
2. Connect one fiber cable between the A side expansion port P2 of the controller unit and the A side port 1B of expansion unit 2.
3. Connect one fiber cable between the B side expansion port P1 of the controller unit and the B side port 1B of expansion unit 1.
4. Connect one fiber cable between the B side expansion port P2 of the controller unit and the B side port 1B of expansion unit 2.

Note – The other drive ports in the units remain empty.

FIGURE 3-7 Controller Unit and Two Expansion Units Cable Interconnection

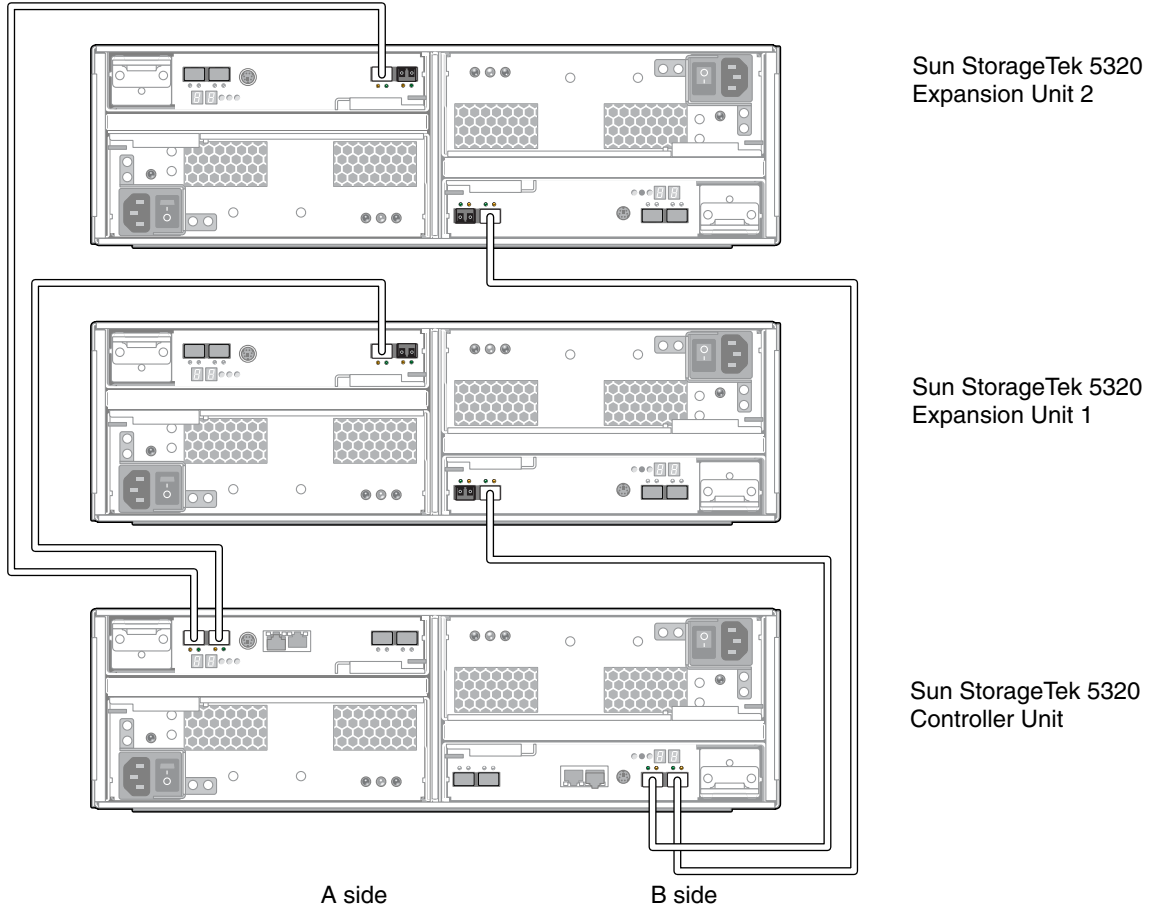

▼ To Cable a Controller Unit to Three Expansion Units

To connect a controller unit and three expansion units, six 2-meter fiber cables are required. Refer to [FIGURE 3-8](#).

1. Connect one fiber cable between the A side expansion port P1 of the controller unit and the A side port 1B of expansion unit 1.
2. Connect one fiber cable between the A side expansion port P2 of the controller unit and the A side port 1B of expansion unit 3.
3. Connect one fiber cable between the A side port 1A of expansion unit 1 and the A side port 1B of expansion unit 2.

4. **Connect one fiber cable between the B side expansion port P1 of the controller unit and the B side port 1B of expansion unit 2.**
5. **Connect one fiber cable between the B side expansion port P2 of the controller unit and the B side port 1B of expansion unit 3.**
6. **Connect one fiber cable between the B side port 1B of expansion unit 1 and the B side port 1A of expansion unit 2.**

Note – The other drive ports in the units remain empty.

FIGURE 3-8 Controller Unit and Three Expansion Units Cable Interconnection

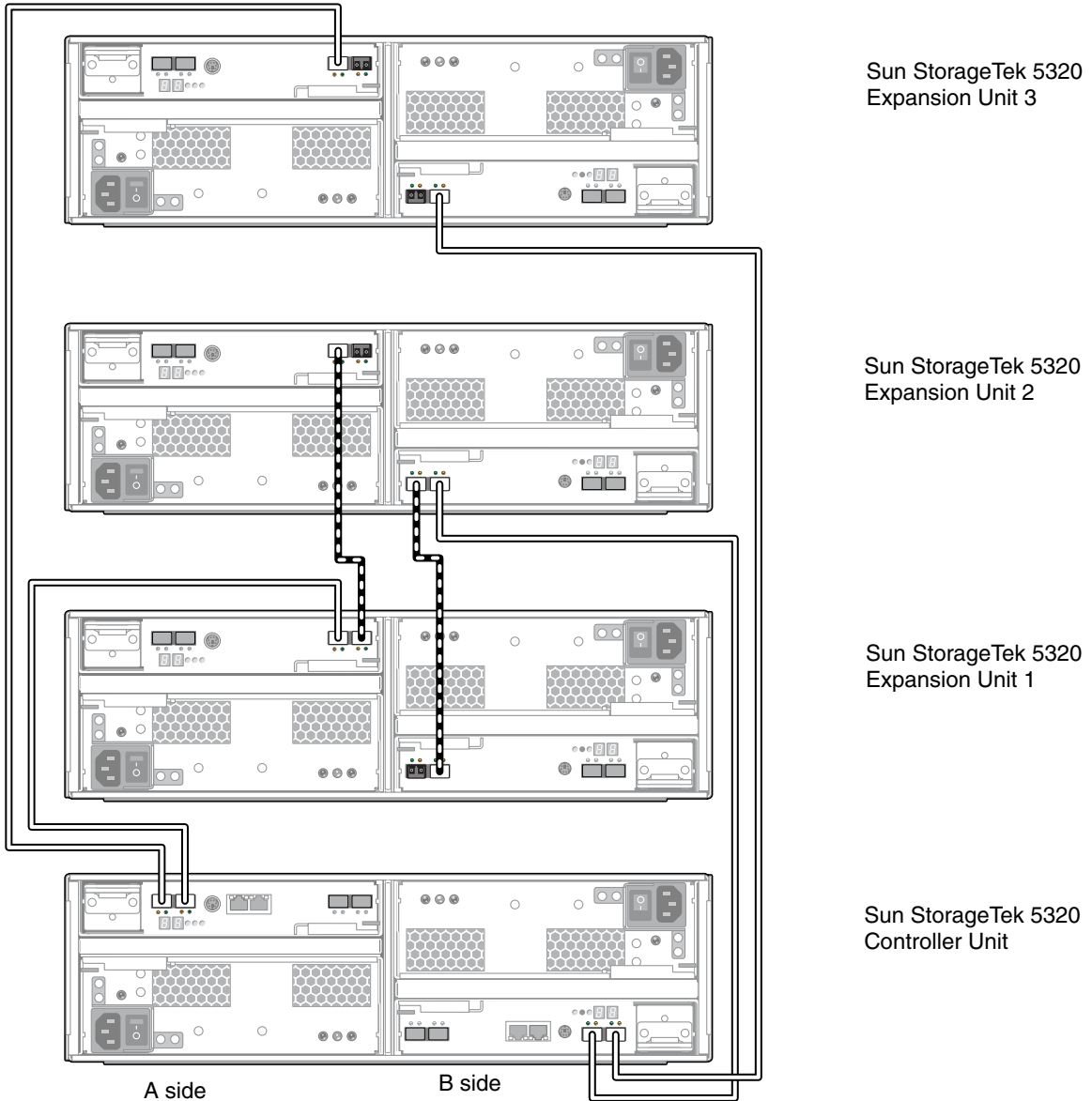

▼ To Cable a Controller Unit to Six Expansion Units

To connect a controller unit and six expansion units, twelve 2-meter fiber cables are required. Refer to [FIGURE 3-9](#).

1. Connect one fiber cable between the A side expansion port P1 of the controller unit and the A side port 1B of expansion unit 1.
2. Connect one fiber cable between the A side expansion port P2 of the controller unit and the A side port 1B of expansion unit 4.
3. Connect one fiber cable between the A side port 1A of expansion unit 1 and the A side port 1B of expansion unit 2.
4. Connect one fiber cable between the A side port 1A of expansion unit 2 and the A side port 1B of expansion unit 3.
5. Connect one fiber cable between the A side port 1A of expansion unit 4 and the A side port 1B of expansion unit 5.
6. Connect one fiber cable between the A side port 1A of expansion unit 5 and the A side port 1B of expansion unit 6.
7. Connect one fiber cable between the B side expansion port P1 of the controller unit and the B side port 1B of expansion unit 3.
8. Connect one fiber cable between the B side expansion port P2 of the controller unit and the B side port 1B of expansion unit 6.
9. Connect one fiber cable between the B side port 1B of expansion unit 1 and the B side port 1A of expansion unit 2.
10. Connect one fiber cable between the B side port 1B of expansion unit 2 and the B side port 1A of expansion unit 3.
11. Connect one fiber cable between the B side port 1B of expansion unit 4 and the B side port 1A of expansion unit 5.
12. Connect one fiber cable between the B side port 1B of expansion unit 5 and the B side port 1A of expansion unit 6.

Note – The other drive ports in the units remain empty.

FIGURE 3-9 Controller Unit and Six Expansion Units Cable Interconnection

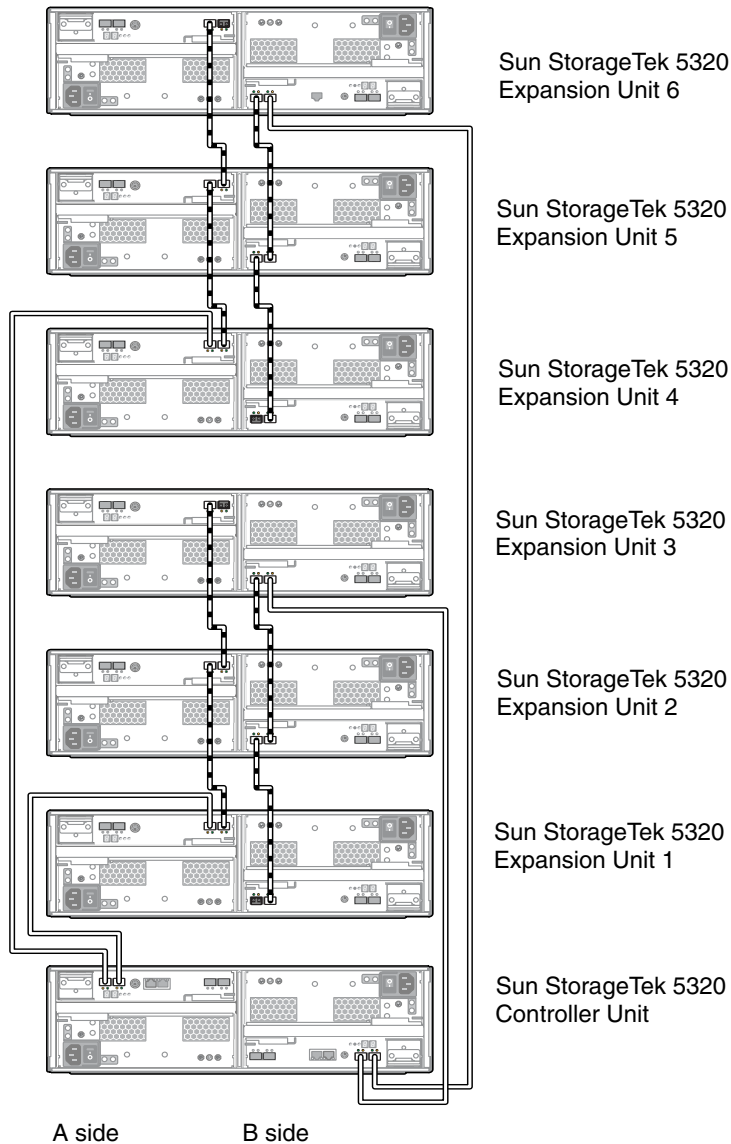

Connecting Existing Sun StorEdge 5300 Controller Enclosures to New Sun StorageTek 5320 Expansion Units

You can connect up to six StorageTek 5320 expansion units to a 5300 RAID EU controller enclosure. The following section provides instructions on how to connect single and dual expansion units to a single controller enclosure.

Note – Do not cable the expansion units to the controller enclosure if you have not upgraded the existing controller enclosure with the controller firmware revision level 06.19.25.10. If you do not upgrade the firmware on the controller enclosure first, it will not recognize the new expansion units. The required firmware patch can be downloaded from <http://sunsolve.sun.com>. You should also upgrade the NAS appliance to the latest OS before proceeding.

Cabling a Single Expansion Unit to a Controller Enclosure with FC Drives

Use the following procedure to cable a new single expansion unit to a 5300 RAID EU controller enclosure. Refer to [FIGURE 3-10](#) for port locations.

▼ To cable a Controller Enclosure to a Single Expansion Unit

1. Connect one fiber cable between the A side expansion port 1 of the controller enclosure and the A side port 1B of the expansion unit.
2. Connect one fiber cable between the B side expansion port 1 of the controller enclosure and the B side port 1B of the expansion unit.

FIGURE 3-10 Controller Enclosure with FC Drives with One Expansion Unit Cable Interconnection

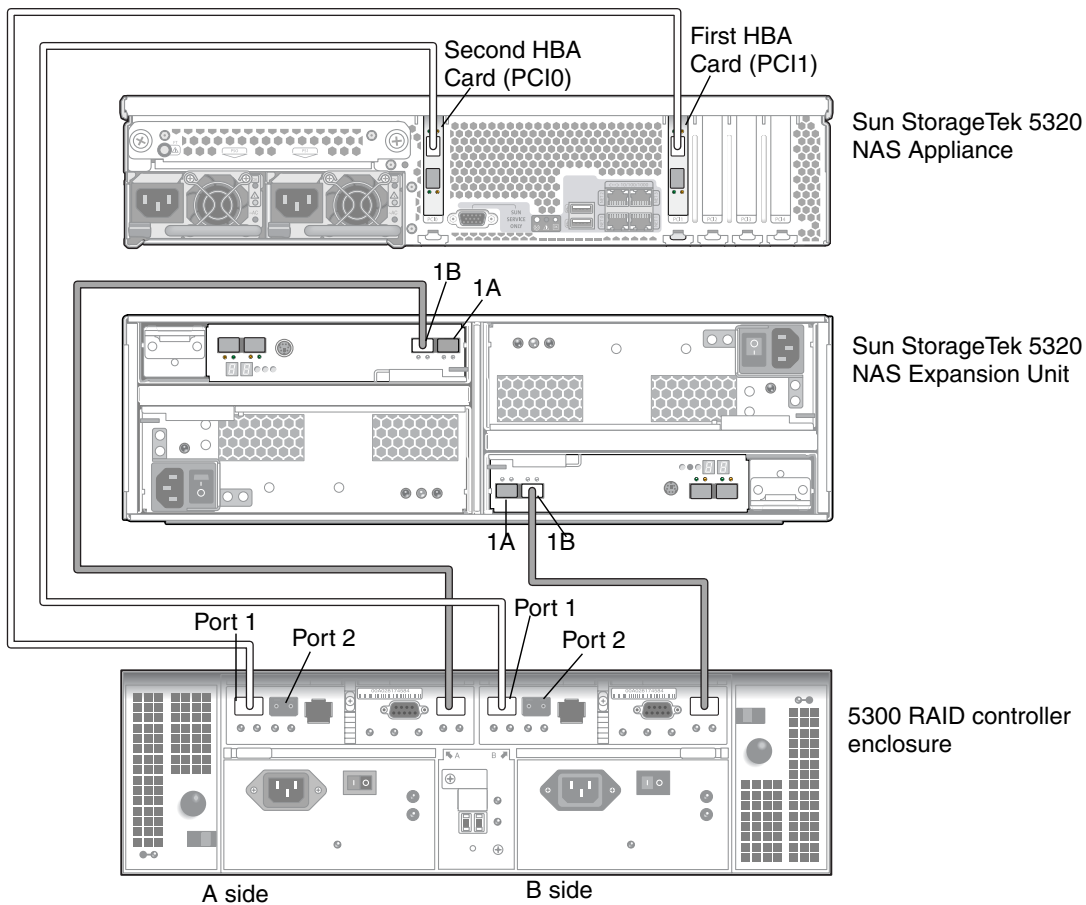

Cabling Two Expansion Units to a Controller Enclosure

Cabling two new expansion units to a 5300 RAID EU controller enclosure differs from cabling a new expansion unit to a new 5320 controller units in that 5300 controller enclosures have only one SFP port on each side of the controller instead of two.

▼ To Cable a Controller Enclosure to Two Expansion Units

To connect a controller unit and two expansion units, four 2-meter fiber cables are required. Refer to [FIGURE 3-11](#).

1. **Connect one fiber cable between the A side expansion port of the controller enclosure and the A side port 1B of expansion unit 1.**
2. **Connect one fiber cable between the A side port 1A of expansion unit 1 and the A side port 1B of expansion unit 2.**
3. **Connect one fiber cable between the B side expansion port of the controller enclosure and the B side port 1B of expansion unit 2.**
4. **Connect one fiber cable between the B side port 1A of expansion unit 2 and the B side port 1B of expansion unit 1.**

FIGURE 3-11 Controller Enclosure with FC Drives with Two Expansion Units

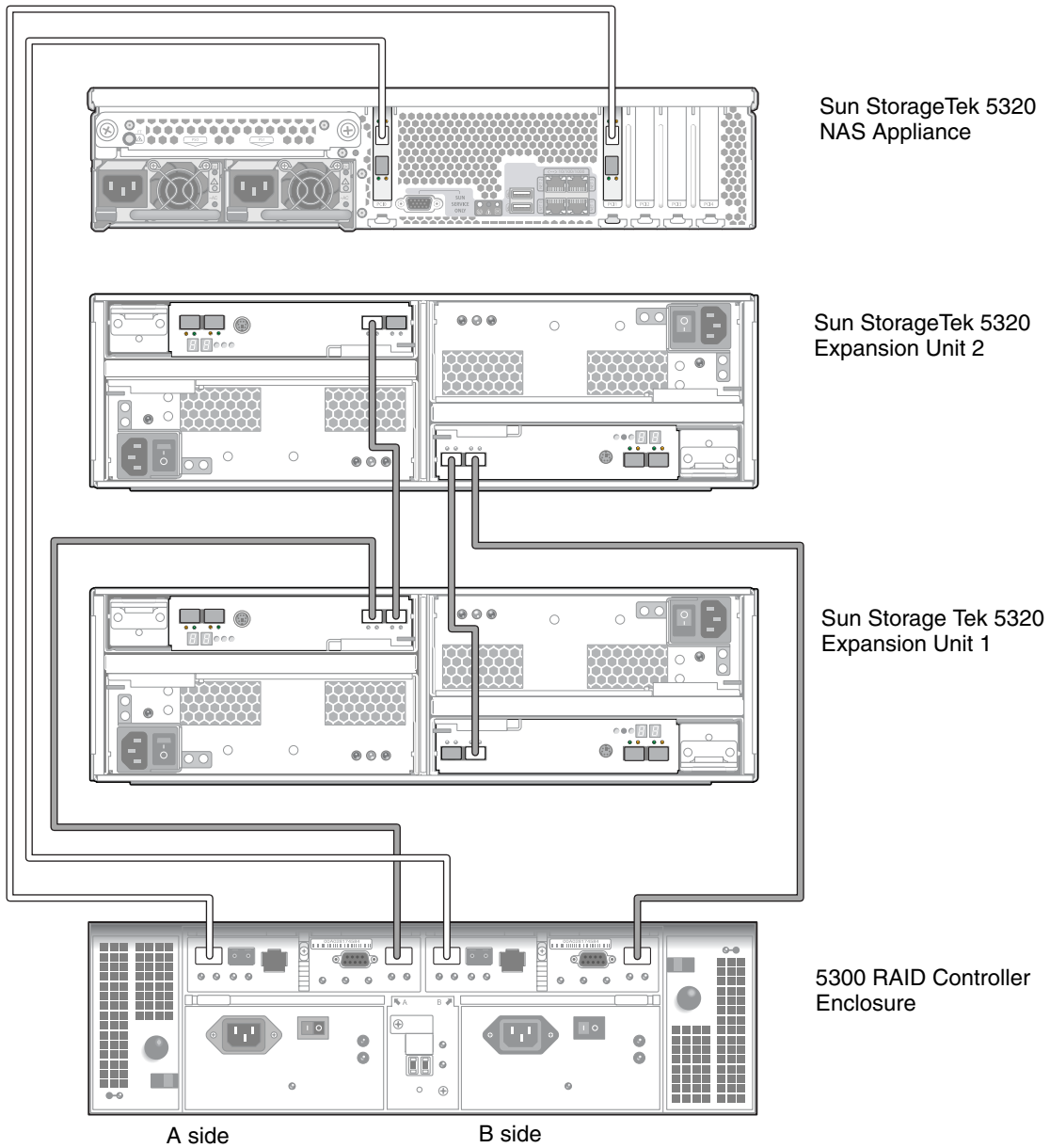

Cabling a Single Expansion Unit to a 5300 SATA Controller Enclosure

If you have a 5300 controller enclosure with SATA drives, use the following procedure to connect a new 5320 expansion unit to the system. Refer to [FIGURE 3-12](#) for port locations.

▼ To Cable a Controller Enclosure with SATA Drives to an Expansion Unit

1. Connect one fiber cable between the A side expansion port of the controller enclosure and the A side port 1 of expansion enclosure 1.
2. Connect one fiber cable between the A side port 2 of expansion enclosure 1 and the A side port 1B of expansion unit 2.
3. Connect one fiber cable between the B side expansion port of the controller enclosure and the B side port 1B of expansion unit 2.
4. Connect one fiber cable between the B side port 1A of expansion unit 2 and the B side port 2 of expansion enclosure 1.

FIGURE 3-12 Controller Enclosure with One Expansion Unit Cable Interconnection with SATA Drives

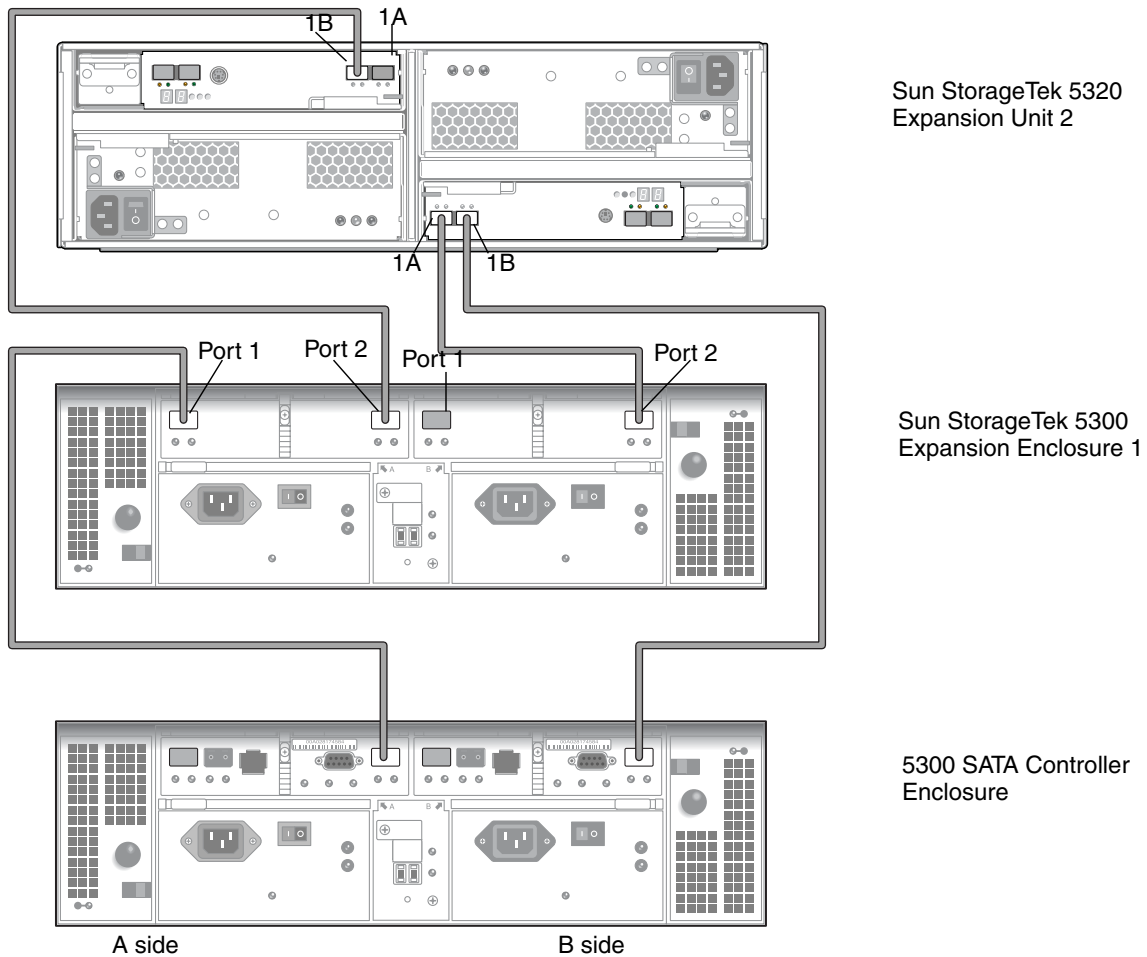

Upgrade Firmware on Expansion Units and Enclosures

After you have cabled the new expansion units in the existing cabinet and powered on the system, you need to upgrade the array firmware on the expansion units and enclosures. The files are included in the Controller Firmware 06.19.25.10 package.

- For new 5320 expansion units, use `esm9884.esm`.
- For existing Fiber Channel 5300 expansion enclosures (5300 EU F), use `esm9643.esm`.
- For existing SATA 5300 expansion enclosures (5300 EU S), use `esm9726.esm`.

Connecting to the Network

Use the following procedures to connect the Sun StorageTek 5320 NAS Appliance to the network. The available network connectors depend on your system configuration: Fast Ethernet or optical Gigabit Ethernet. Each configuration is described in the following sections.

▼ To Connect to Copper Fast Ethernet or Gigabit Ethernet Networks

Refer to [FIGURE 3-13](#) for NIC port locations.

1. To connect the Sun StorageTek 5320 NAS Appliance to a 100BASE-T Fast Ethernet network or to a 1000BASE-T Gigabit Ethernet network, connect an RJ-45 unshielded twisted-pair cable from your local area network (LAN) to port NET0 on the back of the Sun StorageTek 5320 NAS Appliance.
2. For additional LAN connections, continue to connect in order: NET1, NET2, and NET3.

FIGURE 3-13 Connecting to a Fast Ethernet or Gigabit Ethernet Network

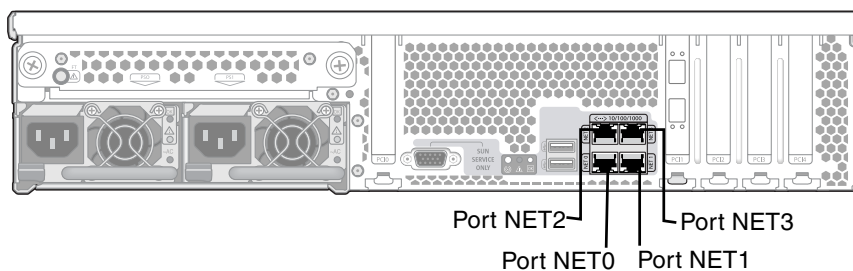

▼ To Connect to Optional Optical Gigabit Ethernet Networks

Refer to [FIGURE 3-14](#) for NIC and optical Gigabit Ethernet port locations.

To connect the Sun StorageTek 5320 NAS Appliance to an optical Gigabit Ethernet network, you must have the optional add-in optical Gigabit Ethernet connections.

- Connect a fiber optic cable from the network to the top (LINK A) and connect another fiber optic cable from the network to the bottom (LINK B) optical Gigabit Ethernet connector on the back of the Sun StorageTek 5320 NAS Appliance.

FIGURE 3-14 Connecting to an Optical Gigabit Network

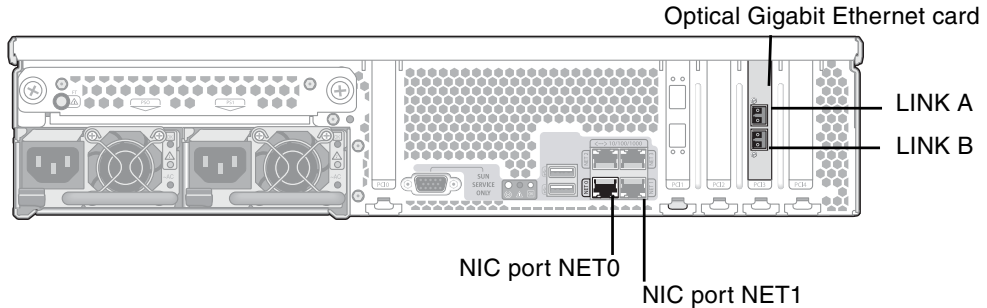

Note – Later, when you configure the system (see [“Initial Sun StorageTek 5320 NAS Appliance Configuration”](#) on page 78), the LINK A port displays as “Port emf3” and the LINK B port displays as “Port emf4.” The NET0 port displays as “Port emc1” and the NET1 port displays as “Port emc2.”

Powering On the Sun StorageTek 5320 NAS Appliance, Controller Units, and Expansion Units

This section describes how to power on the appliance, controller units, and expansion units for the first time. It also details how to power on the system after the initial power-on sequence.

Caution – You must follow the correct initial power-on sequence for your configuration. Failure to follow the correct procedure will result in an inoperative system.

- If you have an appliance and a controller unit only, see [“To Initially Power On the Sun StorageTek 5320 NAS Appliance and Controller Unit”](#) on page 75.

- If you have an appliance, a controller unit, and one or more expansion units, see [“To Initially Power On the Sun StorageTek 5320 NAS Appliance, Controller Units, and Expansion Units”](#) on page 76.
- If you are powering on a system again after initially powering it on, see [“To Power On the Sun StorageTek 5320 NAS Appliance System After Initial Power-On”](#) on page 77.

Note – If you are using a UPS, connect all units to the UPS.

Note – To achieve fault tolerance, units with two power supplies must receive power from two different AC circuits.

▼ To Initially Power On the Sun StorageTek 5320 NAS Appliance and Controller Unit

Note – If you have an appliance and a controller unit only, use this initial power-on sequence. If you also have one or more expansion units, you must use the procedure described in [“To Initially Power On the Sun StorageTek 5320 NAS Appliance, Controller Units, and Expansion Units”](#) on page 76.

1. Verify that all cables between the Sun StorageTek 5320 NAS Appliance and controller units are properly secured according to the instructions in [“Connecting the Sun StorageTek 5320 NAS Appliance to the Controller Unit”](#) on page 54.
2. Power on each controller unit by setting the two power supply switches to the On position.
3. Check that all LEDs on the controller unit front panels have turned solid green, indicating good operation.
4. Verify that the Sun StorageTek 5320 NAS Appliance is connected to the network.
5. Using a pen tip or similar implement, press the recessed Power button ([FIGURE 3-15](#)).

FIGURE 3-15 Power Button and Front Panel Detail

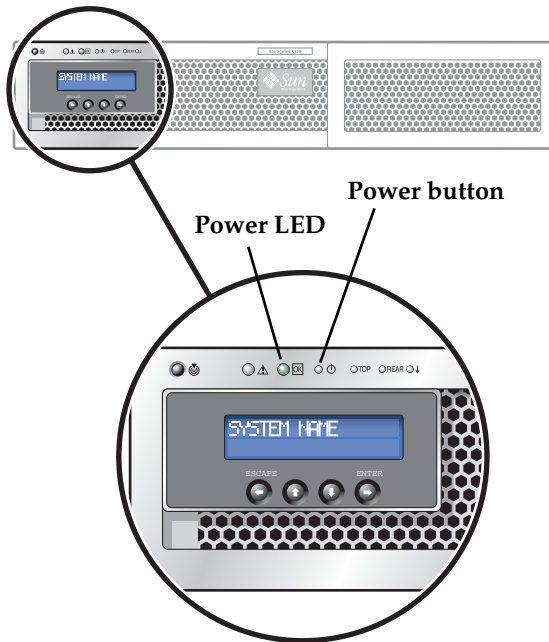

▼ To Initially Power On the Sun StorageTek 5320 NAS Appliance, Controller Units, and Expansion Units

Note – If you have a controller unit and one or more expansion units, you must use this initial power-on sequence. If you do not have any expansion units, you must use the procedure described in [“To Initially Power On the Sun StorageTek 5320 NAS Appliance and Controller Unit”](#) on page 75.

1. Verify that all cables between the Sun StorageTek 5320 NAS Appliance, controller units, and expansion units are properly secured according to the instructions in [“Connecting the Sun StorageTek 5320 NAS Appliance to the Controller Unit”](#) on page 54 and [“Connecting Controller Units to Expansion Units”](#) on page 59.

2. Power on each controller unit by setting the two power supply switches to the On position, and then wait at least 3 minutes for all controllers to completely power on.
3. After 3 minutes, check that all LEDs on the controller unit front panels have turned solid green, indicating good operation.
4. Power on the first expansion unit by setting the two power supply switches to the On position.
5. Check that all LEDs on the expansion unit front panel have turned solid green, indicating good operation.
6. Power on any additional expansion units one at a time, making sure that all LEDs on the front panel of each unit turn solid green and waiting at least 30 seconds before you power on the next unit.
7. After all expansion units have been properly powered on, wait 5 minutes, then proceed to Step 9.
8. Verify that the appliance is connected to the network.
9. Power on the appliance by pressing the recessed Power button located on the front panel.

If necessary, use a pen tip or similar implement to depress the button. Refer to [FIGURE 3-15](#) for a detailed view of the front panel.

▼ To Power On the Sun StorageTek 5320 NAS Appliance System After Initial Power-On

Use this procedure if you need to power on the system again after it has been initially powered on. If the system has never been powered on before, use the procedure described in [“To Initially Power On the Sun StorageTek 5320 NAS Appliance and Controller Unit”](#) on page 75 or [“To Initially Power On the Sun StorageTek 5320 NAS Appliance, Controller Units, and Expansion Units”](#) on page 76.

Note – When you power off the controller units and expansion units, wait 5 seconds before you power them back on. If you power the units off and on too quickly, unexpected results can occur.

1. Verify that all cables between the Sun StorageTek 5320 NAS Appliance, controller units, and expansion units are properly secured according to the instructions in [“Connecting the Sun StorageTek 5320 NAS Appliance to the Controller Unit”](#) on page 54 and [“Connecting Controller Units to Expansion Units”](#) on page 59.
2. Power on each expansion unit by setting the two power supply switches to the On position. Wait at least 30 seconds after powering on each expansion unit.
3. Power on each controller unit by setting the two power supply switches to the On position.
4. Check that all LEDs on the controller unit front panels have turned solid green, indicating good operation.
5. Check that all LEDs on the expansion unit front panels have turned solid green, indicating good operation.
6. Verify that the Sun StorageTek 5320 NAS Appliance is connected to the network.
7. Using a pen tip or similar implement, press the recessed Power button.

Refer to [FIGURE 3-15](#) for a detailed view of the front panel.

Initial Sun StorageTek 5320 NAS Appliance Configuration

To complete the initial Sun StorageTek 5320 NAS Appliance configuration, you must do the following:

- Provide an IP address
- Access the wizard through the Web Administrator
- Follow the instructions provided by the wizard

IP Address Configuration

To configure the Sun StorageTek 5320 NAS Appliance, you must have an IP address for the system. You can assign an IP address in one of two ways:

- Automatic IP address assignment through a Dynamic Host Configuration Protocol (DHCP) server
- Manual IP address assignment through the Liquid Crystal Display (LCD) panel on the Sun StorageTek 5320 NAS Appliance

Automatic (DHCP) IP Address Configuration

To dynamically acquire an IP address through a DHCP server, you must either have an existing DHCP server on the network or have a DHCP relay agent on the network with an accessible DHCP server on another network. If a DHCP server is not available, you must input the IP address through the LCD panel on the front panel of the Sun StorageTek 5320 NAS Appliance.

Note – If your system uses DHCP to assign Domain Name System (DNS) and Microsoft Windows Internet Naming Service (WINS) as well as IP and gateway addresses, the corresponding fields in the wizard and Web Administrator screens are dynamically configured. Verify the information when it is presented by the wizard during system configuration.

If your system supports DHCP, the DHCP server automatically assigns an IP address when the Sun StorageTek 5320 NAS Appliance boots for the first time.

Note – To avoid waiting for DHCP discovery, during the boot sequence when the LCD panel displays “DHCP Discovery NIC X”, you can press any key on the LCD panel and confirm the “Abort DHCP?” message by pressing the ENTER button on the panel. Then you can manually set the static IP address using the following instructions.

▼ To Configure the IP Address Manually

If a DHCP server is not available, you must configure the IP address using the LCD panel.

1. Turn on the Sun StorageTek 5320 NAS Appliance and wait for the boot sequence to complete. The LCD panel displays the following:

A: Set Static IP

B: Retry DHCP

Note – To avoid waiting for DHCP discovery, during the boot sequence when the LCD panel displays “DHCP Discovery NIC X”, you can press any key on the LCD panel and confirm the “Abort DHCP?” message by pressing the ENTER button on the panel.

2. Press the ENTER button once, and then select A. Network Config.
3. Select A to set Gateway, if needed.
4. Select B to set the port-emc1 that corresponds to NIC port NET0.
5. Enter the following values in the order listed:
 - IP address
 - Subnet mask
 - Broadcast address

To enter data, use the up and down arrow buttons to change digits and press the ENTER button to confirm each digit. The cursor moves to the next digit. Once the last digit is set, press the ENTER button again to proceed to the next network setting. After the broadcast address is set, press the ENTER button to return to the Network Config menu.

Accessing the Web Administrator

Note – Before you can access Web Administrator, you must have connected the Sun StorageTek 5320 NAS Appliance to your network, provided an IP address, and prepared a client browser on the same network as the Sun StorageTek 5320 NAS Appliance.

▼ To Connect to the Web Administrator

When you connect to the Web Administrator for the first time, the Configuration Wizard launches automatically.

1. From a client on the same network, open a web browser and type the IP address of the Sun StorageTek 5320 NAS Appliance in the address or location field, for example:

http://123.111.78.99

Press Enter.

Note – If you are using a proxy server and have trouble connecting, try enabling the browser option to bypass the proxy server for local addresses. See your browser's online help or documentation for more information.

The Web Administrator GUI for the Sun StorageTek 5320 NAS Appliance appears in your browser with a login screen.

Note – After you reach the login screen, you might want to bookmark it or add it to your Favorites list so that you do not have to remember the IP address in the future.

2. On the Web Admin login screen, click Apply.

The password can be set later. Refer to the *Sun StorageTek 5320 NAS OS Administration Guide*.

3. On the System Operations, Set Time and Date panel, select the date, the time, and the time zone, and click Apply. Then click Yes to confirm.

This sets the secure clock to the same time and date. Make sure you set the time and date accurately as you can set the secure clock only once.

4. Accept the license agreement to start the Configuration wizard.

If you decline, Web Administrator returns you to the main login screen.

5. Follow the on-screen prompts, entering information as requested.

For more detailed descriptions of the wizard screens, refer to the *Sun StorageTek 5320 NAS OS Administration Guide*.

6. If your system uses DHCP to assign DNS, WINS, or IP and gateway addresses, these fields are automatically configured. When you reach these screens in the wizard, verify the information, and then continue with the wizard.

Note – When adding your DNS server, click Add to ensure the DNS server has been added.

7. On the Confirmation screen, review the configuration information you have added.

Note – Be sure the configuration information is accurate before continuing.

8. Click Finish on the wizard Confirmation screen.

The system configures the settings and indicates that in the Save Configuration screen.

9. Click Close on the Save Configuration screen.

10. Use Web Admin to configure file systems.

Refer to the *Sun StorageTek 5320 NAS OS Administration Guide* for information on creating file systems.

Note – The boot sequence log is located in the bootlog, under `/cvol/log`. The log that the Web Admin GUI displays is a running log that can overflow. If you want to save the entire log, you can set up a local log. See the *Sun StorageTek 5320 NAS OS Administration Guide* for information about initial setup tasks, including setting up a local log.

Installing the Sun StorageTek 5320 NAS Cluster Appliance

This chapter provides comprehensive instructions for connecting the Sun StorageTek 5320 NAS Cluster Appliance, the Sun StorEdge 5300 RAID Controller Enclosures (CUs), and the optional Sun StorEdge 5300 Expansion Enclosures (EUs). It also provides initial configuration instructions for the system.

Note – The Sun StorageTek 5320 NAS Cluster Appliance ships with the operating system installed.

Note – This chapter contains Sun StorageTek 5320 NAS Cluster Appliance connection and configuration instructions only. If you are connecting a different system, refer to the appropriate chapter.

This chapter contains the following sections:

- [“Before You Begin” on page 84](#)
- [“Connecting the Sun StorageTek 5320 NAS Cluster Appliance to Back-End Storage” on page 84](#)
- [“Connecting the Server Health-Monitoring and Network Cables” on page 98](#)
- [“Powering On the Sun StorageTek 5320 NAS Cluster Appliance, Controller Units, and Expansion Units” on page 100](#)
- [“Initial Sun StorageTek 5320 NAS Cluster Appliance Configuration” on page 105](#)

Before You Begin

Before connecting the system, you must install the units in the rack. Refer to [“Installing Servers and Back-End Storage” on page 13](#) for rackmount instructions.

Connecting the Sun StorageTek 5320 NAS Cluster Appliance to Back-End Storage

This section describes how to cable the Sun StorageTek 5320 NAS Cluster Appliance to the controller enclosures and the controller enclosure to the optional expansion enclosures for several different configurations.

This section includes the following tasks:

- [“Connecting the Sun StorageTek 5320 NAS Cluster Appliance to Controller Units” on page 84](#)
- [“Connecting the Controller Units to Expansion Units” on page 90](#)

Connecting the Sun StorageTek 5320 NAS Cluster Appliance to Controller Units

FIGURE 4-1 shows the ports of a cluster appliance and controller units.

FIGURE 4-1 Sun StorageTek 5320 NAS Cluster Appliance HBA Cards and Controller Unit Ports

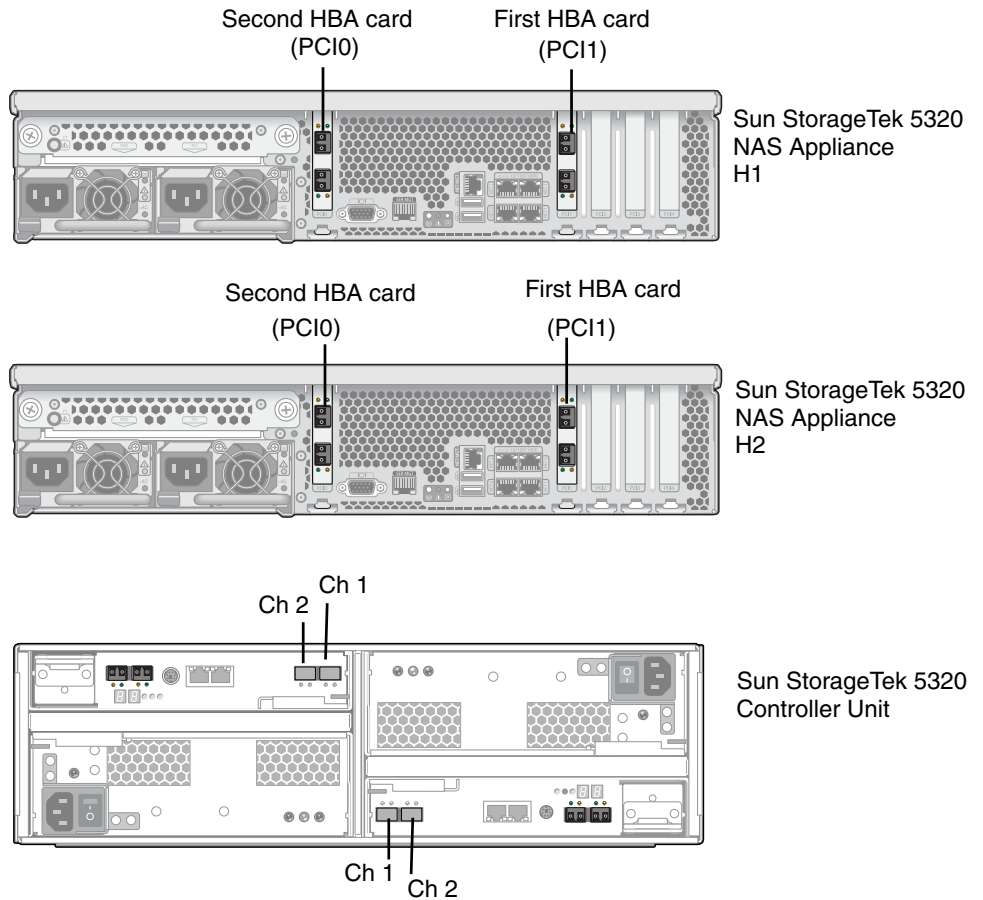

Note – HBA cards for storage connections are inserted only in PCI slot 1 (PCI1) and PCI slot 0 (PCI0) of each server in the Sun StorageTek 5320 NAS Cluster Appliance.

This section contains details on the following:

- [“To Connect One Controller Unit” on page 86](#)
- [“To Connect Two Controller Units” on page 87](#)

▼ To Connect One Controller Unit

Use the instructions in this section if you are connecting one controller unit to the Sun StorageTek 5320 NAS Cluster Appliance.

1. **Connect the HBA port 1 (top port) of the first HBA card (PCI1) on the Sun StorageTek 5320 NAS Cluster Appliance H1 to the Controller A Ch 1 port.**

The H1 and H2 cluster pairs are identified by the software serial number located on a printed label at the front of the server. (See [“Sun StorageTek 5320 NAS Appliance Server”](#) on page 5.)

2. **Connect the HBA port 1 of the second HBA card (PCI0) on the cluster appliance H1 to the Controller B Ch 1 port.**
3. **Connect the HBA port 1 of the first HBA card on the cluster appliance H2 to the Controller A Ch 2 port.**
4. **Connect the HBA port 1 of the second HBA card on the cluster appliance H2 to the Controller B Ch 2 port.**

FIGURE 4-2 Connecting Pairs of HBA Cards to One Controller Unit

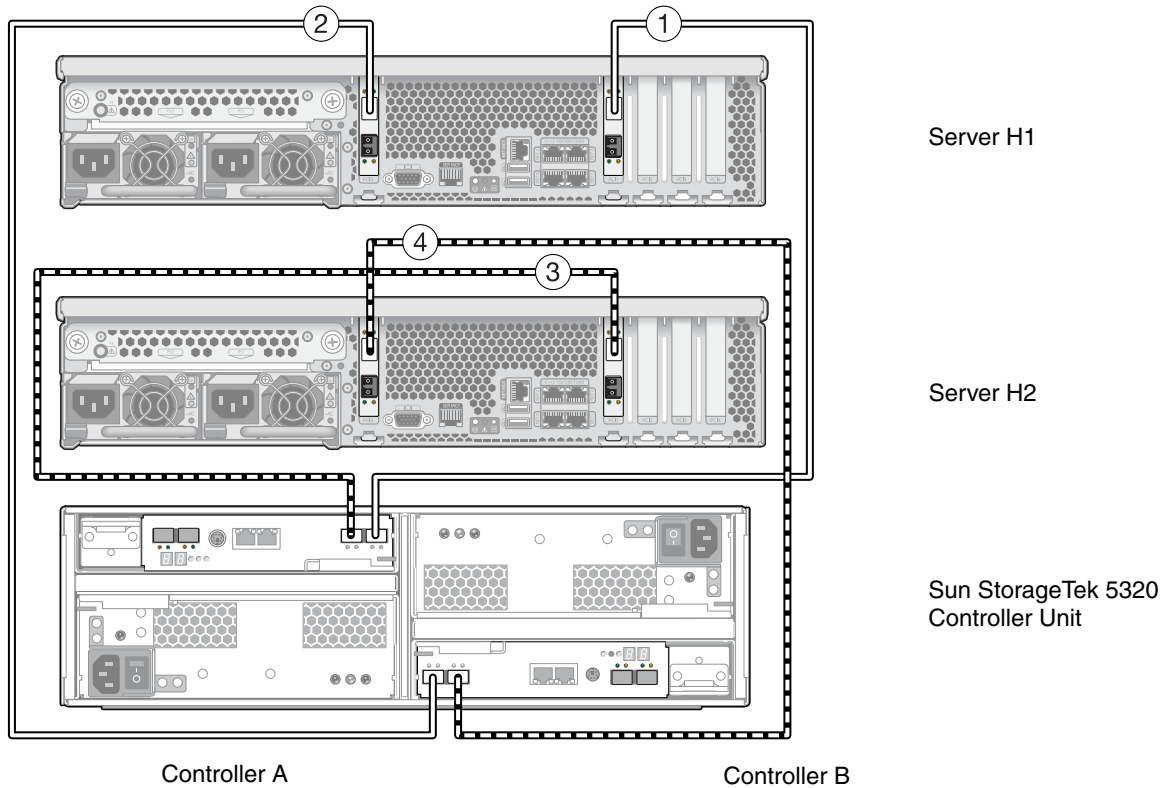

Note – The preceding figure is for illustrative purposes only. The units have more space between them when they are installed in a cabinet.

▼ To Connect Two Controller Units

Use the instructions in this section and refer to [FIGURE 4-3](#) if you are connecting two controller units to the Sun StorageTek 5320 NAS Cluster Appliance.

1. Connect the HBA port 1 (top port) of the first HBA card (PCI1) on the Sun StorageTek 5320 NAS Cluster Appliance server H1 to the Controller A Ch 1 port on the first (bottom) controller unit (Unit 1).
2. Connect the HBA port 2 of the first HBA card on the cluster appliance H1 to the Controller B Ch 1 port on the second (top) controller unit (Unit 2).

3. Connect the HBA port 1 of the second HBA card (PCI0) on the cluster appliance H1 to the Controller B Ch 1 port on Unit 1.
4. Connect the HBA port 2 of the second HBA card on the cluster appliance H1 to the Controller A Ch 1 port on Unit 2.
5. Connect HBA port 1 of the first HBA card (PCI1) on the cluster appliance H2 to the Controller A Ch 2 port on Unit 1.
6. Connect HBA port 2 of the first HBA card on the cluster appliance H2 to the Controller B Ch 2 port on Unit 2.
7. Connect HBA port 1 of the second HBA card (PCI0) on the cluster appliance H2 to the Controller B Ch 2 port on Unit 1.
8. Connect HBA port 2 of the second HBA card on the cluster appliance H2 to the Controller A Ch 2 port on Unit 2.

FIGURE 4-3 Connecting the Sun StorageTek 5320 NAS Cluster Appliance to Two Controller Units

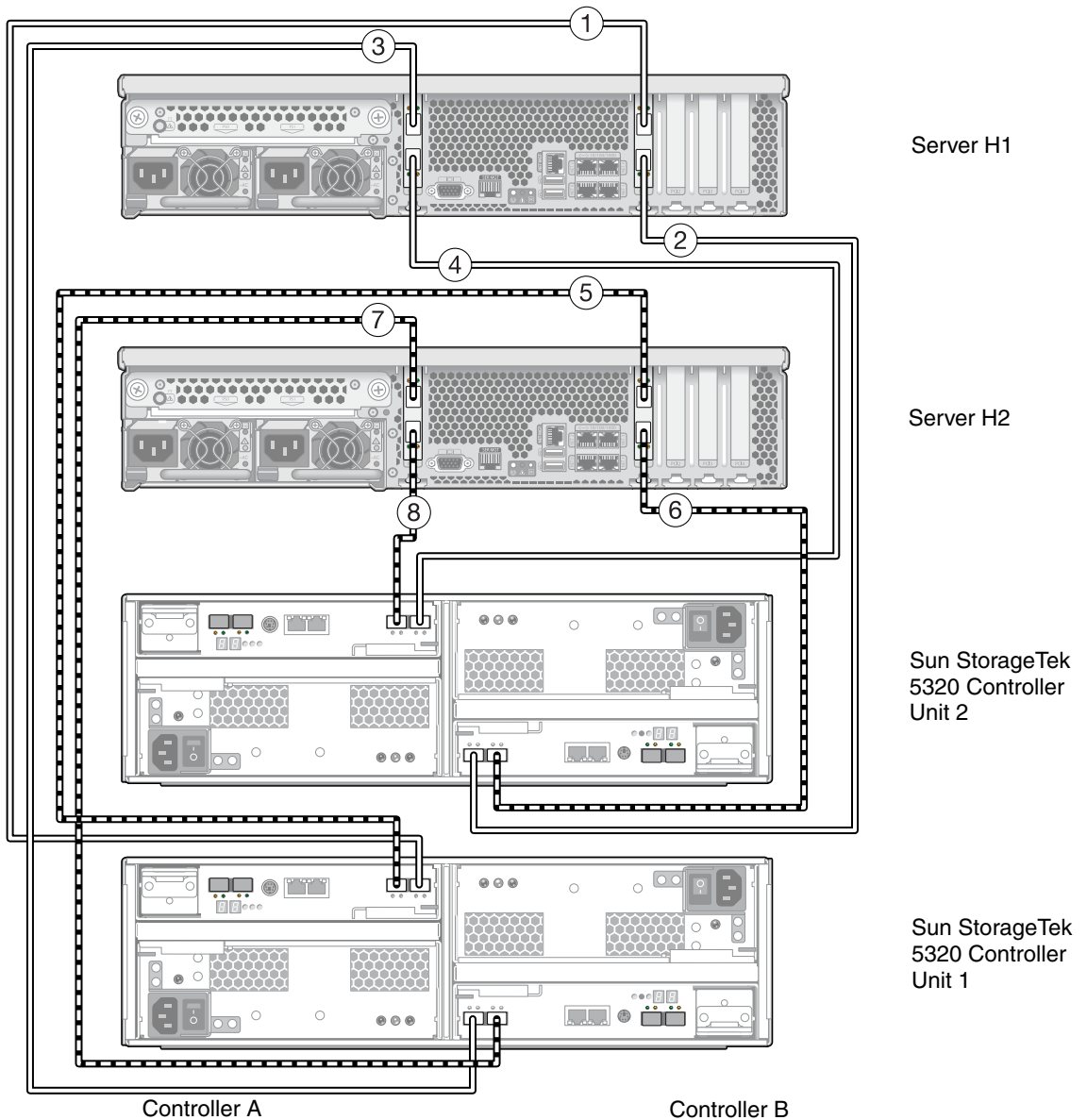

Note – The preceding figure is for illustrative purposes only. The units have more space between them when they are installed in a cabinet.

Connecting the Controller Units to Expansion Units

Each controller unit uses Controller A and Controller B expansion ports to connect to FC-AL ports at the back of an expansion unit (FIGURE 4-4).

FIGURE 4-4 Controller Unit and Expansion Unit Ports

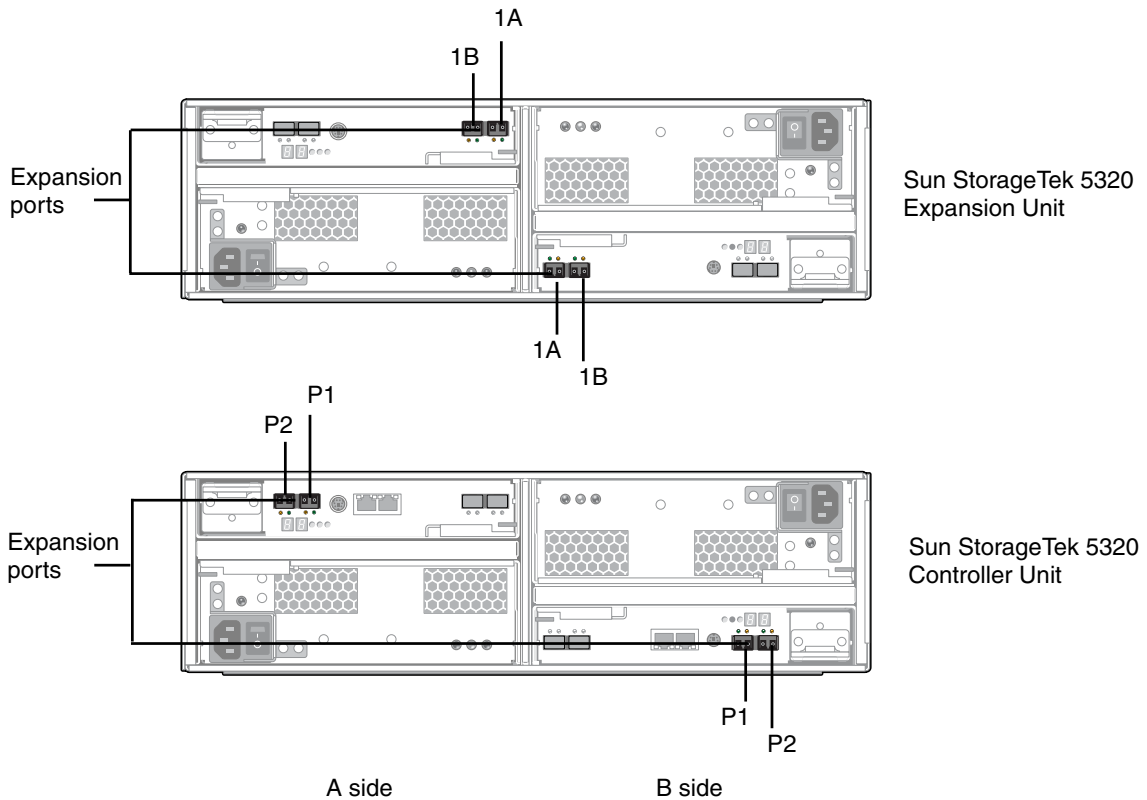

Note – The controller units and the expansion units connect with a pair of optical fiber cables. Optical SFP transceivers have been installed in the controller units' host ports to interface with the optical fiber cable's LC connectors.

Note – This section contains instructions for connecting controller units and expansion units. These instructions apply to one controller unit or to two controller units. If you are using two controller units, follow the same instructions to connect expansion units to *each* controller unit.

A maximum of six expansion units can be attached to each controller unit.

The cabling differs depending on the number of expansion units you are connecting:

- For one expansion unit, refer to [“To Cable a Controller Unit to One Expansion Unit” on page 91](#).
- For two expansion units, refer to [“To Cable a Controller Unit to Two Expansion Units” on page 92](#).
- For three expansion units, refer to [“To Cable a Controller Unit to Three Expansion Units” on page 93](#).
- For four to six expansion units, refer to [“To Cable a Controller Unit to Six Expansion Units” on page 96](#).

▼ To Cable a Controller Unit to One Expansion Unit

To connect a controller unit and one expansion unit, two 2-meter fiber cables are required. Refer to [FIGURE 4-5](#).

1. **Connect one fiber cable between the A side expansion port P1 of the controller unit and the A side port 1B of the expansion unit.**
2. **Connect one fiber cable between the B side expansion port P1 of the controller unit and the B side port 1B of the expansion unit.**

Note – The other drive ports in the units remain empty.

FIGURE 4-5 Controller Unit and One Expansion Unit Cable Interconnection

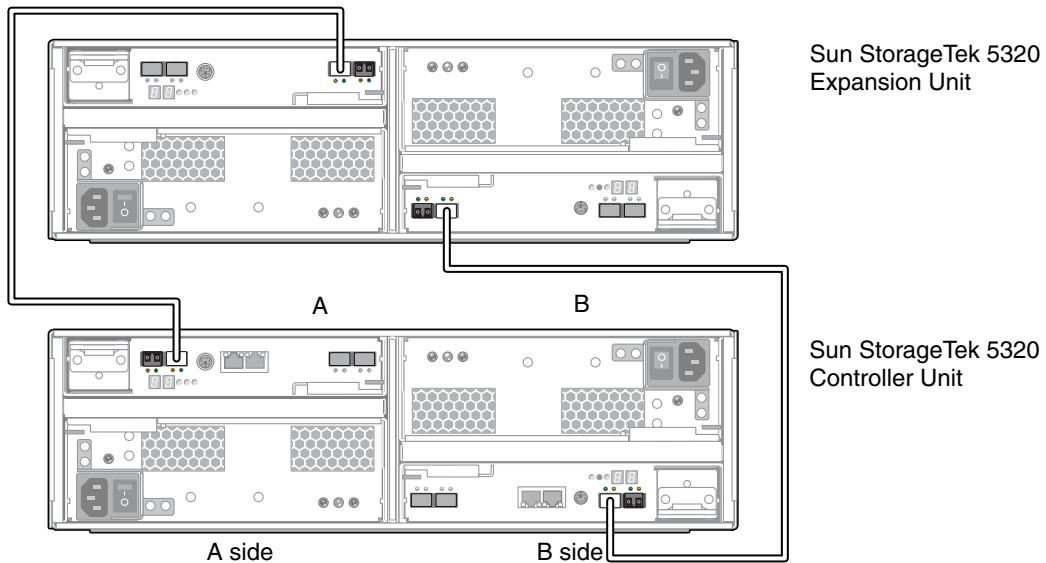

▼ To Cable a Controller Unit to Two Expansion Units

To connect a controller unit and two expansion units, four 2-meter fiber cables are required. Refer to [FIGURE 4-6](#).

1. Connect one fiber cable between the A side expansion port P2 of the controller unit and the A side port 1B of expansion unit 2.
2. Connect one fiber cable between the A side expansion port P1 of the controller unit and the A side port 1B of expansion unit 1.
3. Connect one fiber cable between the B side expansion port P1 of the controller unit and the B side port 1B of expansion unit 1.
4. Connect one fiber cable between the B side expansion port P2 of the controller unit and the B side port 1B of expansion unit 2.

Note – The other drive ports in the units remain empty.

FIGURE 4-6 Controller Unit and Two Expansion Units Cable Interconnection

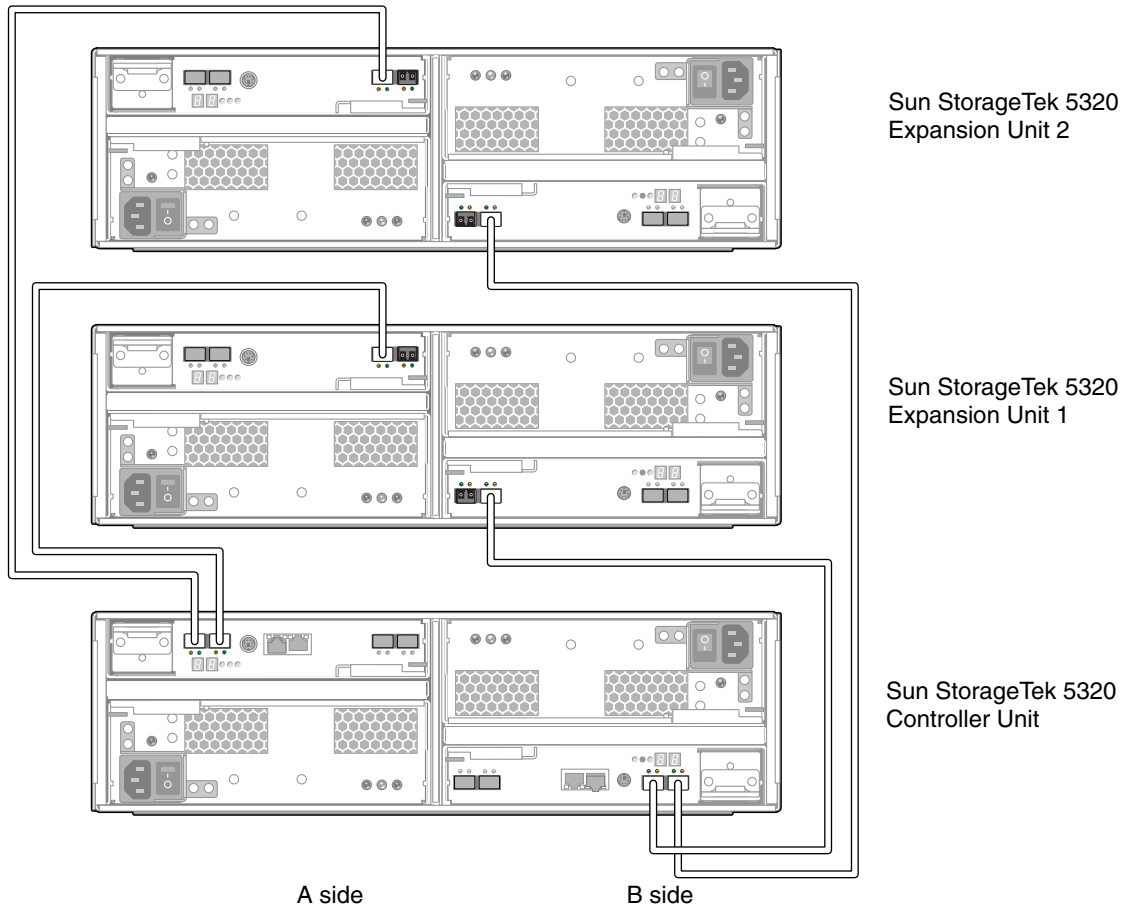

▼ To Cable a Controller Unit to Three Expansion Units

To connect a controller unit and three expansion units, six 2-meter fiber cables are required. Refer to [FIGURE 4-7](#).

1. Connect one fiber cable between the A side expansion port P2 of the controller unit and the A side port 1B of expansion unit 3.
2. Connect one fiber cable between the A side expansion port P1 of the controller unit and the A side port 1B of expansion unit 1.
3. Connect one fiber cable between the A side port 1A of expansion unit 1 and the A side port 1B of expansion unit 2.

4. Connect one fiber cable between the B side expansion port P1 of the controller unit and the B side port 1B of expansion unit 2.
5. Connect one fiber cable between the B side expansion port P2 of the controller unit and the B side port 1B of expansion unit 3.
6. Connect one fiber cable between the B side port 1B of expansion unit 1 and the B side port 1A of expansion unit 2.

Note – The other drive ports in the units remain empty.

FIGURE 4-7 Controller Unit and Three Expansion Units Cable Interconnection

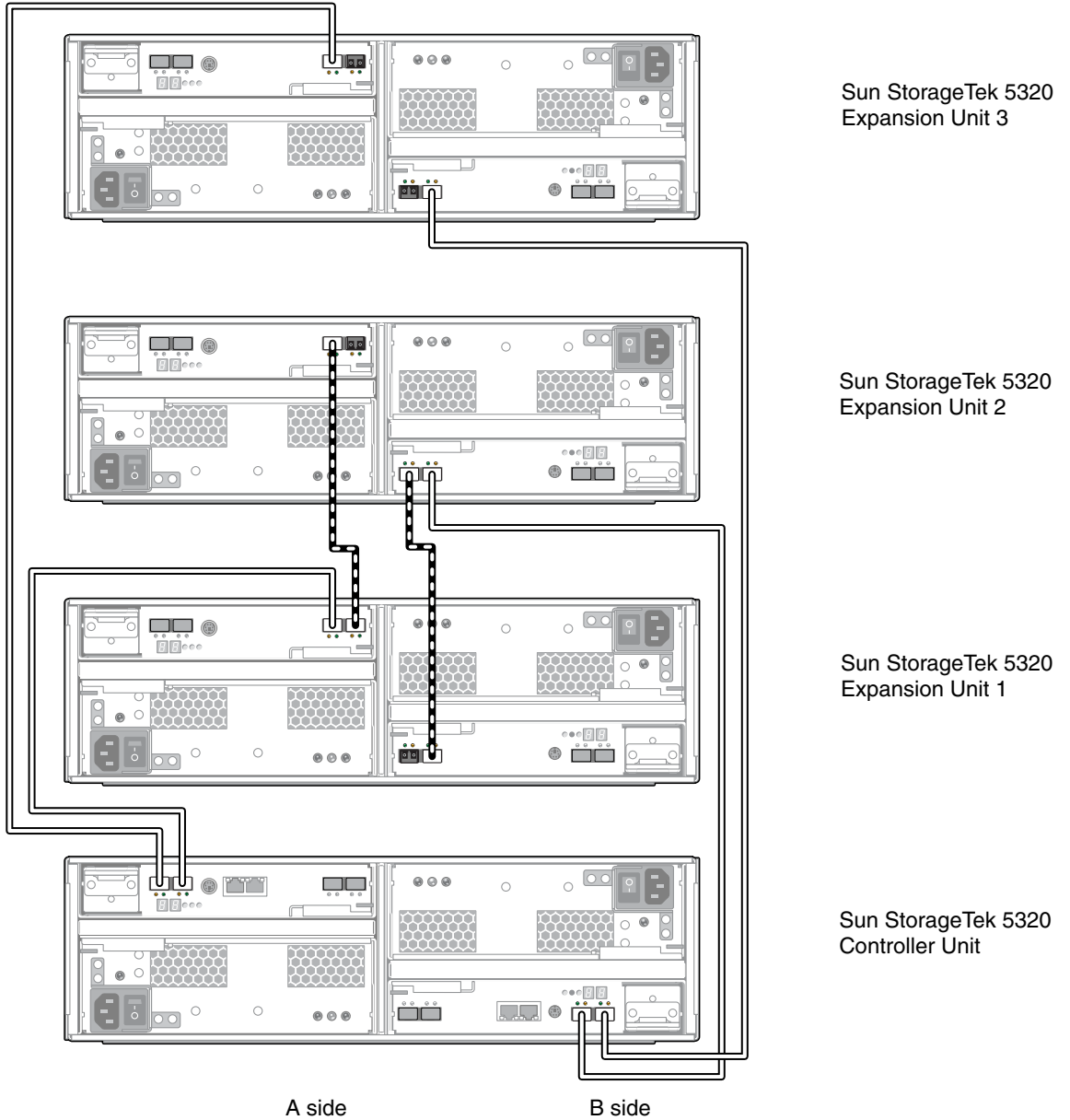

▼ To Cable a Controller Unit to Six Expansion Units

To connect a controller unit and six expansion units, twelve 2-meter fiber cables are required. Refer to [FIGURE 4-8](#).

Note – In a configuration with two controller units, a maximum of four expansion units can be attached to each controller unit.

1. Connect one fiber cable between the A side expansion port P2 of the controller unit and the A side port 1B of expansion unit 4.
2. Connect one fiber cable between the A side expansion port P1 of the controller unit and the A side port 1B of expansion unit 1.
3. Connect one fiber cable between the A side port 1A of expansion unit 1 and the A side port 1B of expansion unit 2.
4. Connect one fiber cable between the A side port 1A of expansion unit 2 and the A side port 1B of expansion unit 3.
5. Connect one fiber cable between the A side port 1A of expansion unit 4 and the A side port 1B of expansion unit 5.
6. Connect one fiber cable between the A side port 1A of expansion unit 5 and the A side port 1B of expansion unit 6.
7. Connect one fiber cable between the B side expansion port P1 of the controller unit and the B side port 1B of expansion unit 3.
8. Connect one fiber cable between the B side expansion port P2 of the controller unit and the B side port 1B of expansion unit 6.
9. Connect one fiber cable between the B side port 1B of expansion unit 1 and the B side port 1A of expansion unit 2.
10. Connect one fiber cable between the B side port 1B of expansion unit 2 and the B side port 1A of expansion unit 3.
11. Connect one fiber cable between the B side port 1B of expansion unit 4 and the B side port 1A of expansion unit 5.
12. Connect one fiber cable between the B side port 1B of expansion unit 5 and the B side port 1A of expansion unit 6.

Note – The other drive ports in the units remain empty.

FIGURE 4-8 Controller Unit and Six Expansion Units Cable Interconnection

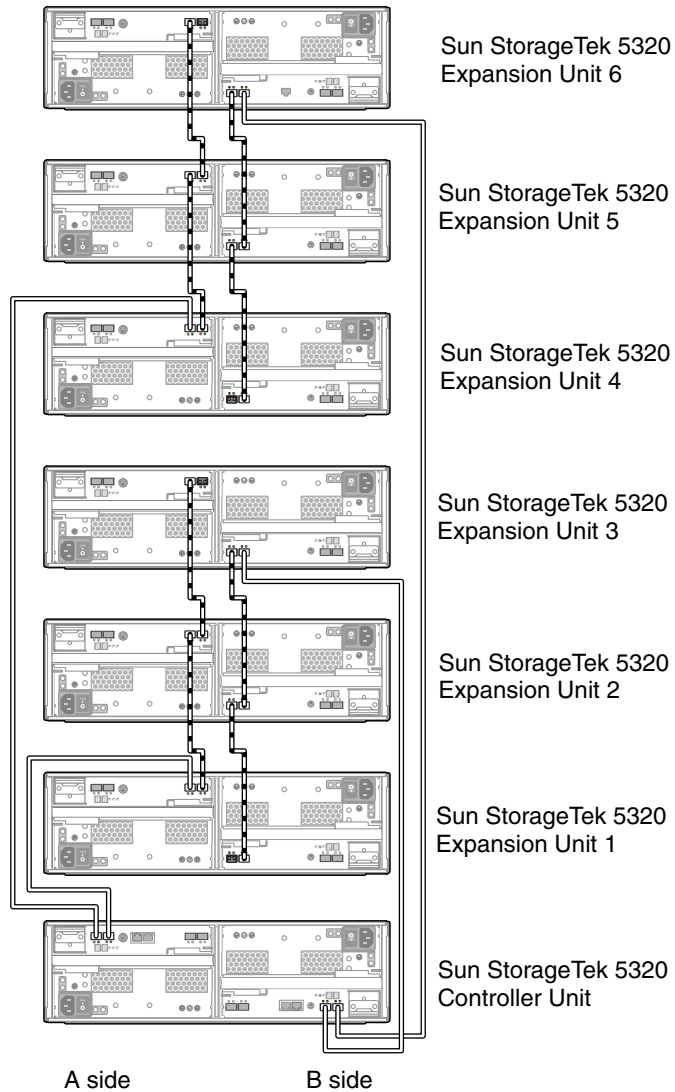

Connecting the Server Health-Monitoring and Network Cables

Each server in a Sun StorageTek 5320 NAS Cluster Appliance uses a dedicated Ethernet connection to communicate with its partner and perform periodic “health checks.” The port used for the health check connection is referred to as the *heartbeat port*. The NET0 Gigabit Ethernet port is used for the heartbeat.

The Sun StorageTek 5320 NAS Cluster Appliance is commonly configured with two Gigabit Ethernet cards. FIGURE 4-9 shows a single card configuration.

FIGURE 4-9 Connecting to an Optical Gigabit Ethernet Network

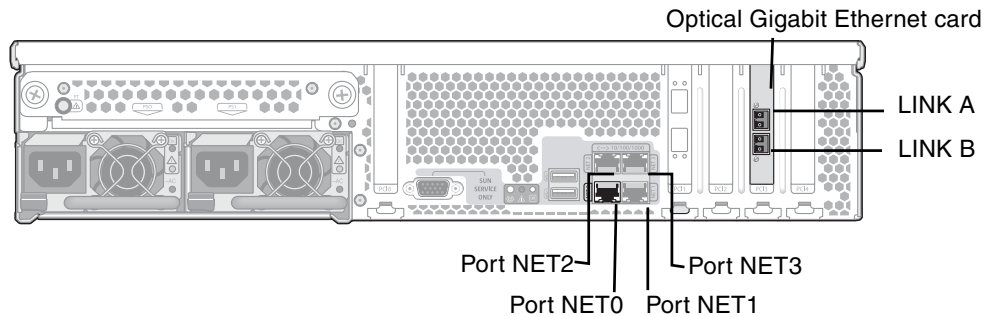

▼ To Connect the Health-Monitoring Cable

- Use a Cat5 Ethernet cable to connect the two servers' NET0 heartbeat ports.

▼ To Connect to Optical Gigabit Ethernet Networks

The appliance must be configured with a second optical Gigabit Ethernet card.

- Connect a fiber optic cable from the network to the top (LINK A) and connect another fiber optic cable from the network to the bottom (LINK B) optical Gigabit Ethernet connector on the back of each of the Sun StorageTek 5320 NAS Cluster Appliances.

Later, when you configure the system (see [“Initial Sun StorageTek 5320 NAS Cluster Appliance Configuration”](#) on page 105), the ports will be identified on the LCD as shown in [TABLE 4-1](#).

TABLE 4-1 Port Identification

Port	Display Identification
H2 LINK A	Port emf5
H2 LINK B	Port emf6
NET0	Port emc1
NET1	Port emc2
NET2	Port emc3
NET3	Port emc4

▼ To Connect to Copper Fast Ethernet or Gigabit Ethernet Networks

If your system is configured for Fast Ethernet or Gigabit Ethernet networking, refer to [FIGURE 4-9](#) for NIC port locations.

- **To connect the Sun StorageTek 5320 NAS Cluster Appliance to a Fast Ethernet or Gigabit Ethernet network, connect an RJ-45 unshielded twisted-pair cable from your local area network (LAN) to the NET1 port on the back of each of the Sun StorageTek 5320 NAS Cluster Appliances. For additional LAN connections, continue to connect in order: NET2 and NET3.**

Powering On the Sun StorageTek 5320 NAS Cluster Appliance, Controller Units, and Expansion Units

This section describes how to power on the appliance, controller units, and expansion units for the first time. It also details how to power on the system after the initial power-on sequence.



Caution – You must follow the correct initial power-on sequence for your configuration. Failure to follow the correct procedure will result in an inoperative system.

- If you have an appliance and a controller unit only, see [“To Initially Power On the Sun StorageTek 5320 NAS Cluster Appliance and Controller Unit”](#) on page 100.
- If you have an appliance, a controller unit, and one or more expansion units, see [“To Initially Power On the Sun StorageTek 5320 NAS Cluster Appliance, Controller Unit, and Expansion Unit”](#) on page 102.
- If you are powering on a system again after initially powering it on, see [“To Power On the Sun StorageTek 5320 NAS Cluster Appliance System After Initial Power-On”](#) on page 104.

Note – If you are using a UPS, connect all units to the UPS.

Note – To achieve fault tolerance, units with two power supplies must receive power from two different AC circuits.

▼ To Initially Power On the Sun StorageTek 5320 NAS Cluster Appliance and Controller Unit

Note – If you have an appliance and a controller unit only, use this initial power-on sequence. If you also have one or more expansion unit, you must use the procedure described in [“To Initially Power On the Sun StorageTek 5320 NAS Cluster Appliance, Controller Unit, and Expansion Unit”](#) on page 102.

1. Verify that all cables between the Sun StorageTek 5320 NAS Cluster Appliance and controller enclosures are properly secured according to the instructions in [“Connecting the Sun StorageTek 5320 NAS Cluster Appliance to Controller Units”](#) on page 84.
2. Verify that the Cat5 Ethernet cable is connected between the heartbeat ports according to the instructions in [“Connecting the Server Health-Monitoring and Network Cables”](#) on page 98.
3. Power on each controller unit by setting the two power supply switches to the On position.
4. Check that all LEDs on the controller unit front panels have turned solid green, indicating good operation.
5. Verify that the Sun StorageTek 5320 NAS Cluster Appliance is connected to the network.

Note – Power on and configure one server at a time.

6. Power on server H1 (software serial number ending in “-H1”) by using a pen tip or similar implement to press the recessed Power button ([FIGURE 4-10](#)).

Note – To determine the H1 server, look for the software serial number (ending in -H1) on the label that is affixed to the back panel of the appliance server. If the label is not located at the back of the server, check the sheet metal on the left side of the appliance server.

FIGURE 4-10 Power Button and Front Panel Detail

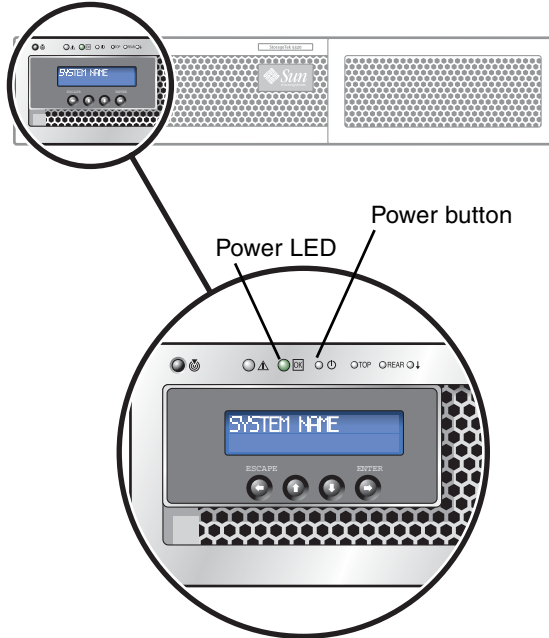

Caution – Do not power up server H2 until directed in the instructions that follow.

7. Verify that server H1 has finished booting up, as indicated by the LCD display “QUIET.”
8. To complete the power-on sequence, continue with the next section, [“Initial Sun StorageTek 5320 NAS Cluster Appliance Configuration”](#) on page 105.

▼ To Initially Power On the Sun StorageTek 5320 NAS Cluster Appliance, Controller Unit, and Expansion Unit

Note – If you have a controller unit and one or more expansion units, you must use this initial power-on sequence. If you do not have any expansion units, you must use the procedure described in [“To Initially Power On the Sun StorageTek 5320 NAS Cluster Appliance and Controller Unit”](#) on page 100.

1. Verify that all cables between the Sun StorageTek 5320 NAS Cluster Appliance and controller enclosures are properly secured according to the instructions in [“Connecting the Sun StorageTek 5320 NAS Cluster Appliance to Controller Units”](#) on page 84.
2. Verify that the Cat5 Ethernet cable is connected between the heartbeat ports according to the instructions in [“Connecting the Server Health-Monitoring and Network Cables”](#) on page 98.
3. Power on each controller unit by setting the two power supply switches to the On position, and wait at least 3 minutes for all controllers to completely power on.
4. After 3 minutes, check that all LEDs on the controller unit front panels have turned solid green, indicating good operation.
5. Power on the first expansion unit by setting the two power supply switches to the On position.
6. Check that all LEDs on the expansion unit front panel have turned solid green, indicating good operation.
7. Power on any additional expansion units one at a time, making sure that all LEDs on the front panel of each unit turn solid green and waiting at least 30 seconds before you power on the next unit.
8. After all expansion units have been properly powered on, wait 5 minutes, then proceed to [Step 9](#).
9. Verify that the appliance is connected to the network.

Note – Power up and configure one server at a time.

10. Power on server H1 (software serial number ending in “-H1”) by using a pen tip or similar implement to press the recessed Power button. Refer to [FIGURE 4-10](#) for a detailed illustration of the front panel.



Caution – Do not power up server H2 until directed in the instructions that follow.

11. Verify that server H1 has finished booting up, as indicated by the LCD display “QUIET.”
12. To complete the power-on sequence, continue with the next section, [“Initial Sun StorageTek 5320 NAS Cluster Appliance Configuration”](#) on page 105.

▼ To Power On the Sun StorageTek 5320 NAS Cluster Appliance System After Initial Power-On

Note – Use this procedure if you need to power on the system again after it has been initially powered on. If the system has never been powered on before, use the procedure described in [“To Initially Power On the Sun StorageTek 5320 NAS Cluster Appliance and Controller Unit”](#) on page 100 or [“To Initially Power On the Sun StorageTek 5320 NAS Cluster Appliance, Controller Unit, and Expansion Unit”](#) on page 102.



Caution – When you power off the controller enclosures and expansion units, wait 5 seconds before you power them back on. If you power the units off and on too quickly, unexpected results can occur.

1. **Verify that all cables between the Sun StorageTek 5320 NAS Cluster Appliance, controller enclosures, and expansion units are properly secured according to the instructions in [“Connecting the Sun StorageTek 5320 NAS Cluster Appliance to Controller Units”](#) on page 84 and [“Connecting the Controller Units to Expansion Units”](#) on page 90.**
2. **Verify that the Cat5 Ethernet cable is connected between the heartbeat ports according to the instructions in [“Connecting the Server Health-Monitoring and Network Cables”](#) on page 98.**
3. **Power on each expansion unit by setting the two power supply switches to the On position. Wait at least 30 seconds before powering on each expansion unit.**

Note – If the expansion unit contains SATA disk drives, only the Power LED turns solid green. The drive LEDs turn solid green only after the controller enclosure is powered on.

4. **Power on each controller enclosure by setting the two power supply switches to the On position.**
5. **Check that all LEDs on the controller enclosure front panels have turned solid green, indicating good operation.**
6. **Check that all LEDs on the expansion unit front panels have turned solid green, indicating good operation.**
7. **Verify that the Sun StorageTek 5320 NAS Cluster Appliance is connected to the network.**

Note – Power up and configure one server at a time.

8. Power on server H1 (software serial number ending in “-H1”) by using a pen tip or similar implement to press the recessed Power button. Refer to [FIGURE 4-10](#) for a detailed illustration of the front panel.



Caution – Do not power up server H2 until directed in the instructions that follow.

9. Verify that server H1 has finished booting up, as indicated by the LCD display “QUIET.”
10. To complete the power-on sequence, continue with the next section, [“Initial Sun StorageTek 5320 NAS Cluster Appliance Configuration”](#) on page 105.

Initial Sun StorageTek 5320 NAS Cluster Appliance Configuration

To complete the initial Sun StorageTek 5320 NAS Cluster Appliance configuration, you must specify the following:

- IP addresses
- Basic configuration information
- Failover configuration information
- LUN ownership
- LUN paths

▼ To Set IP Addresses

You assign a static IP address using the server H1’s LCD panel.

1. Select Menu.
2. Select A. Network Config.

3. Select A. Set Gateway and enter the gateway address.

To enter data, use the up and down arrow buttons to change digits and press the ENTER button to confirm each digit. The cursor moves to the next digit. Once the last digit is set, press the ENTER button again to proceed to the next network setting. After the broadcast address is set, press the ENTER button to return to the Network Config menu.

4. Select C. Set Port-emc2 and enter the IP address, subnet mask, and broadcast address as prompted.

This IP address information is assigned to the first regular (non-heartbeat) LAN port, emc2, on your system.



Caution – Do not change the private IP address on the network port that is used for the HB Port (heartbeat port).

5. Select Escape twice to return to the main menu.

Note – If you would like to verify your settings on the LCD panel, HB Port shows a private IP address, and Port emc2 (the first regular LAN port) shows the information you just entered.

You can edit the port information and assign addresses to other ports in the same way.

6. From server H1's LCD menu, select C. Take All LUNs and press the ENTER button.

7. When prompted to "take all LUNs," press the up arrow button to select "Yes," and press the ENTER or right arrow button to start taking LUNs.

The LCD displays "Taking LUNs" followed by a message "Took *n* LUNs." After a few seconds, the display returns to the Network Config menu.

8. Select Escape to return to the main menu.

Server H1 is now in the ALONE state.

9. Power on the server H2 (software serial number ending in "-H2") by pressing the recessed Power button.

10. Wait until server H2's LCD display status is QUIET.

11. Use the instructions in [Step 1](#) through [Step 5](#) to assign server H2's IP address and gateway address.

▼ To Configure the System

To configure the system using the Web Admin application, follow these instructions:

1. **From a client on the same network, open a Java platform-enabled web browser with Java Plug-in and enter the IP address for server H1.**
2. **Accept the “Applet Security Certificate” and wait until the Web Admin applet is loaded on this system.**
3. **On the Web Admin login screen, click Apply.**

The password can be set later. Refer to the *Sun StorageTek 5320 NAS OS Administration Guide*.

4. **On the Set Time and Date panel, select the date, the time, and the time zone, and click Apply. Then click Yes to confirm.**

This sets the secure clock to the same time and date. Make sure you set the time and date accurately as you can set the secure clock only once.

5. **Read the license agreement in the Configuration wizard dialog box, and click Accept.**
6. **Click Next in the Welcome dialog box, and proceed with the following steps:**
 - a. **From the Select Environment screen, configure Microsoft Windows, UNIX, or both environments, and click Next to continue.**
 - b. **From the Set Server Name screen, type the server name and populate the other fields accordingly, and then click Next.**
 - c. **From the Enable Failover screen, select Automatic Failover and Enable Link Failover.**

A default value of 60 seconds is assigned in both the Down Timeout and Restore Timeout fields.

- d. **Type the Partner Configuration Name and the Gateway IP address for server H2 (Partner Name factory default is “head2”), and click Apply.**

The information you enter here is used to start server H2. The Partner Name is the host name you want to assign to server H2. Any network information server H2 obtained manually through the LCD panel is displayed here and can be corrected, if necessary.

The field for Private IP should already be populated and must not be changed.

- e. **Click Next.**

- f. **On the Configure Network Adapters screen, verify that the information is correct.**

You can configure additional network interfaces at this time. However, if you change the configuration of the port to which the browser is attached, the browser session is disconnected.

- g. **Click Next to continue.**

- h. **On the Set Gateway Address screen, verify that the address is correct, and, if not, enter the gateway address. Click Next to continue.**

7. **For all the other wizard configuration steps, refer to the *Sun StorageTek 5320 NAS OS Administration Guide* for more information.**

Note – When adding your DNS server, click Add to ensure the DNS server has been added.

8. **On the Confirmation screen, review the configuration information you have added.**

Note – Be sure the configuration information is accurate before continuing.

9. **Click Finish on the wizard Confirmation screen.**

The system configures the settings and indicates that in the Save Configuration screen. It also displays a message that both servers must reboot for the failover changes to be applied.

10. **Click Close on the Save Configuration screen.**

▼ To Assign LUN Ownership

To finish the configuration process, you must assign LUN ownership for both servers.

1. **Launch a new browser window and type server H1's IP address.**
2. **On the Web Admin login screen, click Apply. A password is not required.**

The password can be set later. Refer to the *Sun StorageTek 5320 NAS OS Administration Guide*.

3. **From the navigation panel, select High Availability > Recover.**

Check the status of the recover process in the logging window (bottom pane).

4. In the Restore RAID Configuration window, assign some of the LUNs to server H2.

Note – You must assign at least one LUN to each server. In most situations, you will want approximately equal amounts of storage assigned to each server in the cluster.

5. Click Apply.

Note – The appropriate LUN assignments are saved in the (New) Restore RAID Configuration window.

6. Click Recover, and the LUNs are distributed between both the servers.

At this point, both servers change to the NORMAL state.

Note – Verify that both servers are in the NORMAL state on the LCD Panel display or on the Web Admin main page, where the Head Status and Partner Status should display NORMAL.

▼ To Assign LUN Paths

You need to assign LUN paths on each server to balance multipath access from each server to each storage controller.

- You can use the Web Admin to automatically assign LUN paths by selecting High Availability > Set LUN Path > Auto assign LUN Path.
- You can also automatically assign LUN paths using the CLI Auto-assign LUN paths option on the LUN Paths screen.

Refer to the *Sun StorageTek 5320 NAS OS Administration Guide* for additional information about manually assigning LUN paths and other detailed software setup and use.

▼ To Configure the Partner

For server H2, repeat all steps in [“To Configure the System” on page 107](#) with the following exceptions:

- In [Step 6 d.](#) in [“To Configure the System” on page 107](#), enter the information for the partner H1 server.

- As you complete the configuration process, there is no message to reboot the servers, since you do not need to reboot the servers

Installing the Sun StorageTek 5320 NAS Gateway System

This chapter provides comprehensive instructions for connecting a Sun StorageTek 5320 NAS Gateway System or Sun StorageTek 5320 NAS Cluster Gateway System to SAN storage. It also provides initial configuration instructions for the system.

Note – If you are installing a different system, refer to the appropriate chapter.

The Sun StorageTek 5320 NAS Gateway System can be directly attached or attached through fabric switches to a Sun StorageTek 6130/6140/6540 array, a Sun StorEdge 6920 system, Sun StorEdge FlexLine 200 and 300 series, or a Sun StorEdge 9970/9980/9985/9990 system (shortened to “Sun StorEdge 99xx system” in this chapter).

Note – Refer to the Sun StorageTek 5320 NAS Gateway System web page for the most current SAN storage information.

This chapter contains the following sections:

- [“Before You Begin” on page 112](#)
- [“Installation and Configuration Task Overview” on page 113](#)
- [“Connecting the Sun StorageTek 5320 NAS Gateway System to the Sun StorageTek 6130/6140/6540 Array” on page 114](#)
- [“Connecting the Gateway System to the Sun StorageTek FlexLine 200 and 300 Series” on page 126](#)
- [“Connecting the Sun StorageTek 5320 NAS Gateway System to the Sun StorEdge 6920 System” on page 135](#)
- [“Connecting the Gateway System or Gateway Cluster System to the Sun StorEdge 99xx System” on page 145](#)
- [“Connecting to the Network” on page 154](#)

- “Powering On the Gateway System” on page 156
- “Initial Gateway System Single-Server Configuration” on page 159
- “Initial Cluster Gateway System Configuration” on page 166
- “SAN Storage Configuration” on page 173

Note – The Sun StorageTek 5320 NAS Gateway System and Sun StorageTek 5320 NAS Cluster Gateway System ship with the operating system installed.

Before You Begin

Before connecting the system, do the following:

- If desired, install the Sun StorageTek 5320 NAS Gateway System or Sun StorageTek 5320 NAS Cluster Gateway System and switch or switches, if used, in a cabinet. Follow the installation instructions in Chapter 2 for [“Installing a Server in a Cabinet” on page 33](#).
- Set up the SAN storage devices, referring, if necessary, to your SAN storage documentation.

You will configure storage after the Sun StorageTek 5320 NAS Gateway System is installed and set up.

Installation and Configuration Task Overview

To set up the Sun StorageTek 5320 NAS Gateway System, perform the tasks in table 5-1. To ensure a successful installation, perform the tasks in the order in which they are presented.

TABLE 5-1 Sun StorageTek 5320 NAS Gateway System Task Overview

Step	Task	Where to Find Procedure
1.	Connect to SAN storage.	<ul style="list-style-type: none">• Refer to the instructions for your SAN storage:• “Connecting the Sun StorageTek 5320 NAS Gateway System to the Sun StorageTek 6130/6140/6540 Array” on page 114• “Connecting the Gateway System to the Sun StorageTek FlexLine 200 and 300 Series” on page 126• “Connecting the Sun StorageTek 5320 NAS Gateway System to the Sun StorEdge 6920 System” on page 135• “Connecting the Gateway System or Gateway Cluster System to the Sun StorEdge 99xx System” on page 145
2.	Connect to the network.	Refer to “Connecting to the Network” on page 154.
3.	Power on the system.	Refer to “Powering On the Gateway System” on page 156.
4.	Configure the system by doing the following: <ol style="list-style-type: none">1. Set up IP addresses.2. Configure the basic system.3. Activate the license.4. Configure SAN storage.5. Configure Sun StorageTek 5320 NAS Gateway System storage.6. For cluster configuration only, configure failover.7. Set LUN paths.	<ul style="list-style-type: none">• For the single-server configuration, refer to “Initial Gateway System Single-Server Configuration” on page 159.• For the cluster configuration, refer to “Initial Cluster Gateway System Configuration” on page 166.

Storage Concepts

Each Sun StorageTek 5320 NAS Gateway System server contains two dual port HBA cards. Using pairs of optical fiber cables, you can connect to storage directly or by using Fibre Channel switches.

When the Sun StorageTek 5320 NAS Gateway System is connected directly to storage without using a Fibre Channel switch, it is referred to as a “direct attach” configuration. Storage is configured using LUN masking.

Most Sun StorageTek 5320 NAS Gateway Systems are connected to SAN storage using a Fibre Channel switch, which is referred to as a “fabric attach.” Because a switch can be a single point of failure, multiple switches can be used. Multiple switches can be configured with LUN masking to allocate storage to specific servers.

To ensure redundancy, you should connect to SAN storage port pairs.

A maximum of four heterogeneous storage systems can be attached per Gateway system configuration, single head or cluster.

Connecting the Sun StorageTek 5320 NAS Gateway System to the Sun StorageTek 6130/6140/6540 Array

This section describes how to cable the Sun StorageTek 5320 NAS Gateway System directly or through fabric switches to the Sun StorageTek 6130/6140/6540 array:

- [“Connecting Directly to the Sun StorageTek 6130/6140/6540 Array” on page 116](#)
- [“Using Fabric Switches to Connect to the Sun StorageTek 6130/6140/6540 Array” on page 120](#)

After connecting the systems, proceed to [“Connecting to the Network” on page 154](#).

Sun StorageTek 6540 Array Controller Ports

Throughout this section, illustrations show connections for the Sun StorageTek 6130 array. When connecting the Sun StorageTek 6540 array, you will use the controller ports with the same nomenclature; however, the ports appear in a different location on the Sun StorageTek 6540 array, as shown in [FIGURE 5-1](#).

FIGURE 5-1 Sun StorageTek 6540 Array

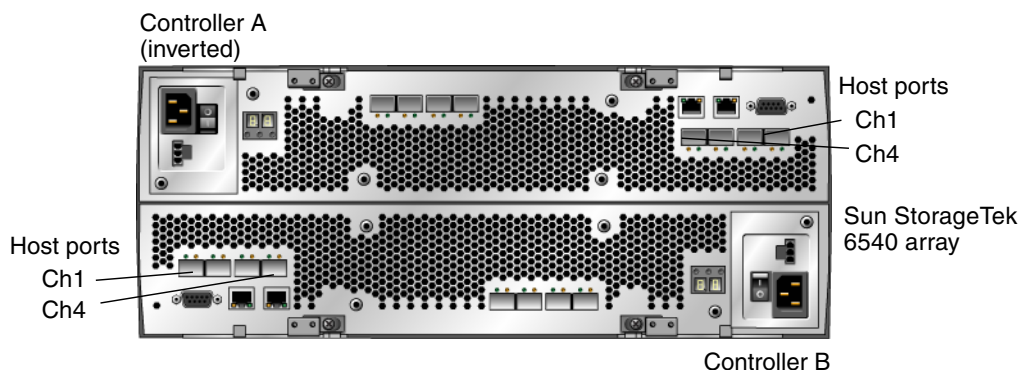

Required Software and Firmware

The Gateway system requires software release 4.20 (minimum) for gateway support.

The Sun StorageTek 6540 array requires the minimum software and firmware versions listed in [TABLE 5-2](#).

TABLE 5-2 Required Sun StorageTek 6540 Array Software and Firmware

Software	Version (minimum)
Sun StorageTek 6540 array management software	CAM 5.0
Controller CRM-F firmware	06.16.81.10
Array firmware installer	N6091-616843-005

Sun StorageTek 6140 Array Controller Ports

Throughout this section, illustrations show connections for the Sun StorageTek 6130 array. When connecting the Sun StorageTek 6140 array, you will use the controller ports with the same nomenclature; however, the ports appear in a different location on the Sun StorageTek 6140 array, as shown in [FIGURE 5-2](#).

FIGURE 5-2 Sun StorageTek 6140 Array Controller Ports

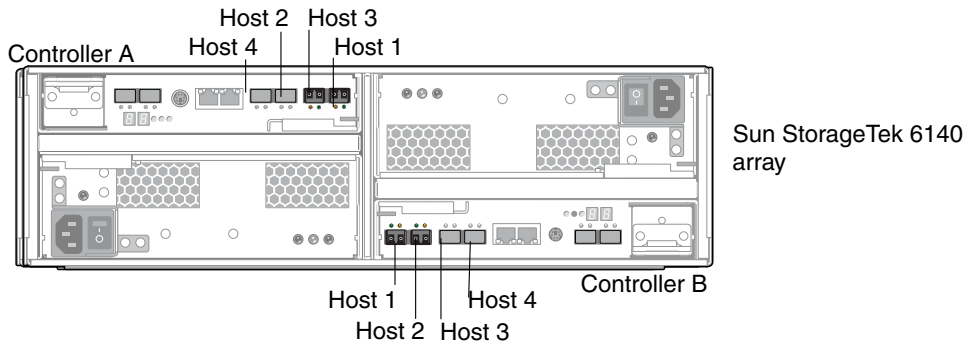

Connecting Directly to the Sun StorageTek 6130/6140/6540 Array

The following direct attach configurations are described in this section:

- [“To Connect a Single-Server Direct Attach to the Sun StorageTek 6130/6140/6540 Array” on page 116](#)
- [“To Connect a Dual-Server Direct Attach to the Sun StorageTek 6130/6140/6540 Array” on page 118](#)

Note – Do not power on the server until instructed in [“Powering On the Gateway System” on page 156](#).

▼ To Connect a Single-Server Direct Attach to the Sun StorageTek 6130/6140/6540 Array

You can connect to SAN storage with one pair of optical fiber cables.

1. Connect the HBA Port 1 of the first HBA card (PCI1) to the Controller A host 1 port on the Sun StorageTek 6130/6140/6540 array.
2. Connect the HBA Port 1 of the second HBA card (PCI0) to the Controller B host 1 port on the Sun StorageTek 6130/6140/6540 array.

FIGURE 5-3 Connecting Two HBA Ports to the Sun StorageTek 6130 Array

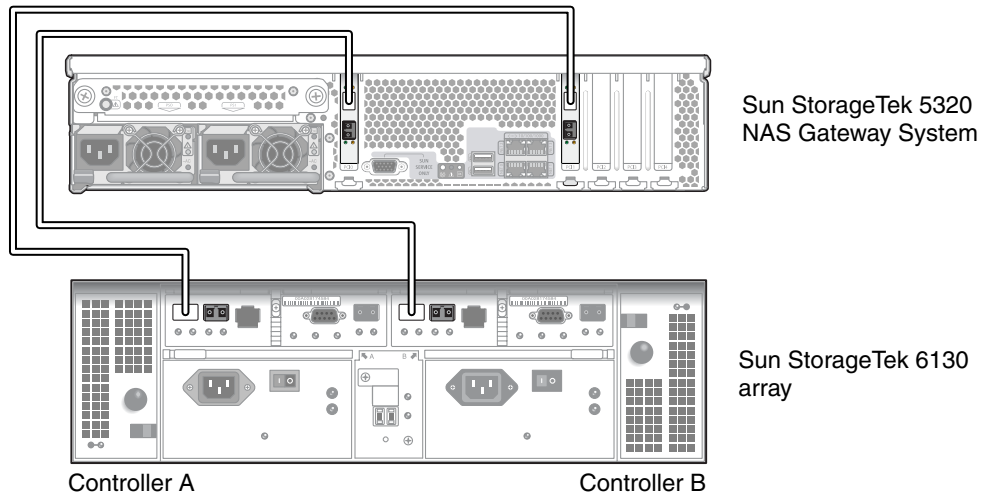

3. (Optional) For additional redundancy, attach the additional HBA ports.
 - a. Connect the HBA Port 2 of the first HBA card to the Controller B host 2 port on the Sun StorageTek 6130/6140/6540 array.
 - b. Connect the HBA Port 2 of the second HBA card to the Controller A host 2 port on the Sun StorageTek 6130/6140/6540 array.

FIGURE 5-4 Connecting All HBA Ports to the Sun StorageTek 6130 Array

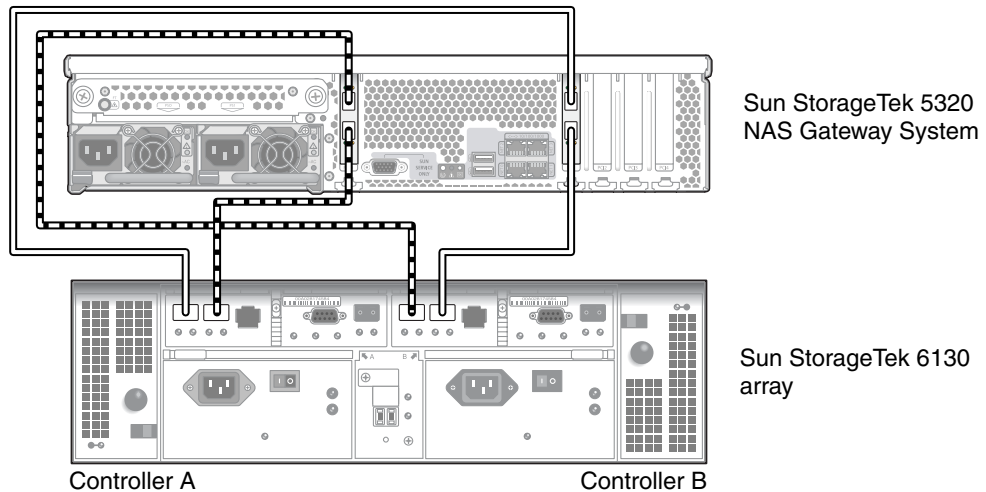

▼ To Connect a Dual-Server Direct Attach to the Sun StorageTek 6130/6140/6540 Array

You can connect a dual-server high-availability (HA) Sun StorageTek 5320 NAS Cluster Gateway System to SAN storage with two optical fiber cables from each server.

Note – Each head must have two Fibre Channel connections to a SAN storage unit. One Fibre connection is insufficient for proper HA functionality.

1. Connect the HBA Port 1 of the first HBA card (PCI1) on server H1 to the Controller A host 1 port on the Sun StorageTek 6130/6140/6540 array.
2. Connect the HBA Port 1 of the second HBA card (PCI0) on server H1 to the Controller B host 1 port on the Sun StorageTek 6130/6140/6540 array.
3. Connect the HBA Port 1 of the first HBA card on server H2 to the Controller A host 2 port on the Sun StorageTek 6130/6140/6540 array.
4. Connect the HBA Port 1 of the second HBA card on server H2 to the Controller B host 2 port on the Sun StorageTek 6130/6140/6540 array.

FIGURE 5-5 Connecting Two HBA Ports per HA Server to the Sun StorageTek 6130 Array

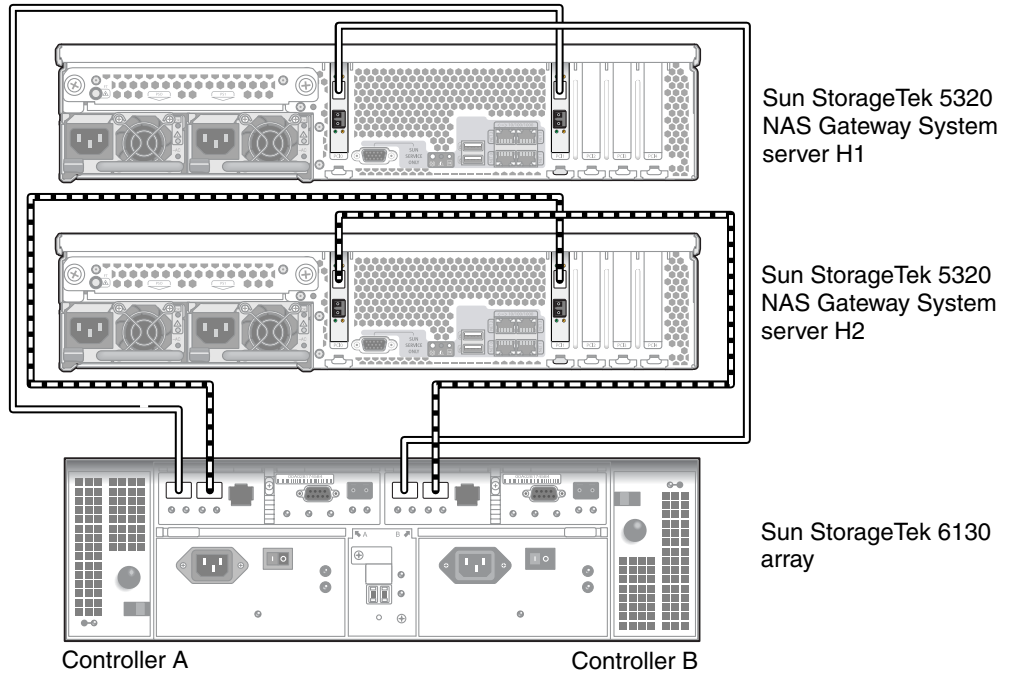

Using Fabric Switches to Connect to the Sun StorageTek 6130/6140/6540 Array

The following fabric attach configurations are described in this section:

- [“To Connect a Single-Server Fabric Attach to the Sun StorageTek 6130/6140/6540 Array” on page 120](#)
- [“To Share All Sun StorageTek 6130 Array LUNs Between All Port Pairs” on page 122](#)
- [“To Connect a Dual-Server High-Availability Fabric Attach to the Sun StorageTek 6130/6140/6540 Array” on page 124](#)

Note – Do not power on the server until instructed in [“Powering On the Gateway System” on page 156](#).

Configure zoning of the FC switch so that a single host bus adapter (HBA) can access only one port (often referred to as "one-to-one" zoning). When necessary, you can also configure "overlapping" zones. Refer to your fabric switch documentation for additional information about zoning configuration.

▼ To Connect a Single-Server Fabric Attach to the Sun StorageTek 6130/6140/6540 Array

You can connect to SAN storage with one or two pairs of optical fiber cables. Using two pairs to connect all HBA ports and using two switches ensures redundancy and improves processing speed.

In the following illustration, port zones are shaded to indicate unique zones.

1. **Connect the HBA Port 1 of the first HBA card (PCI1) to the first available port of the first fabric switch.**
2. **Connect the HBA Port 1 of the second HBA card (PCI0) to the first available port of the second fabric switch.**
3. **Connect an available port on the first switch to the Controller A host 1 port on the Sun StorageTek 6130/6140/6540 array.**
4. **Connect an available port on the second switch to the Controller B host 1 port on the Sun StorageTek 6130/6140/6540 array.**

FIGURE 5-6 Connecting Two HBA Ports Using Fabric Switches to the Sun StorageTek 6130/6140/6540 Array

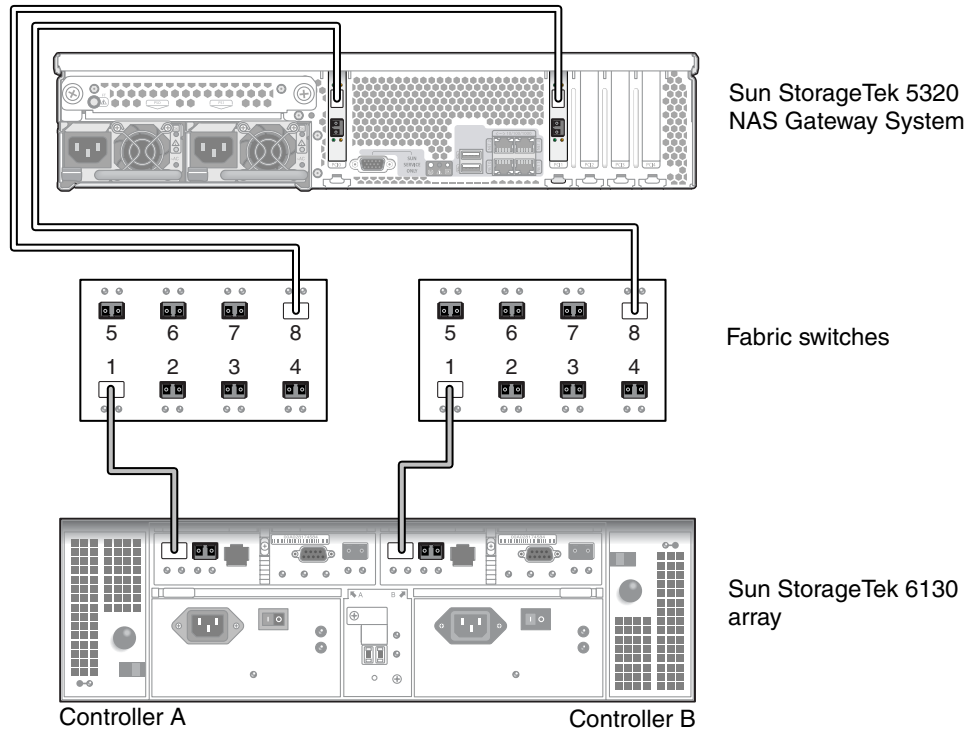

5. (Optional) For additional redundancy, attach the additional HBA ports:

- a. Connect the HBA Port 2 of the first HBA card to the next available port of the second fabric switch.
- b. Connect the HBA Port 2 of the second HBA card to the next available port of the first fabric switch.

FIGURE 5-7 Connecting All HBA Ports Through Fabric Switches to the Sun StorageTek 6130/6140 Array

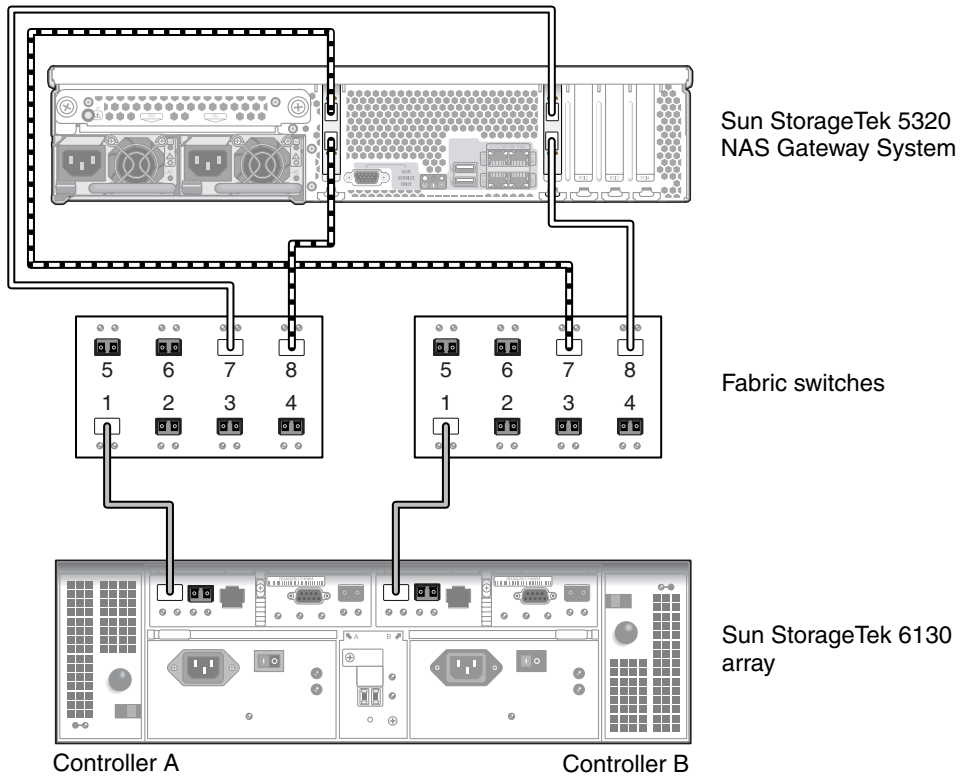

▼ To Share All Sun StorageTek 6130 Array LUNs Between All Port Pairs

To enable all LUNs to be shared between all port pairs, attach the four HBA ports to two switches and use four cables to attach the switches to the Sun StorageTek 6130/6140 array:

1. Connect the HBA Port 1 of the first HBA card (PCI1) to the first available port of the first fabric switch.
2. Connect the HBA Port 1 of the second HBA card (PCI0) to the first available port of the second fabric switch.
3. Connect the HBA Port 2 of the first HBA card to the next available port of the second fabric switch.

4. Connect the HBA Port 2 of the second HBA card to the next available port of the first fabric switch.
5. Connect an available port on the first switch to the Controller A host 1 port on the Sun StorageTek 6130/6140 array.
6. Connect an available port on the second switch to the Controller B host 1 port on the Sun StorageTek 6130/6140 array.

FIGURE 5-8 Connecting All HBA Ports Through Two Fabric Switches to the Sun StorageTek 6130/6140 Array

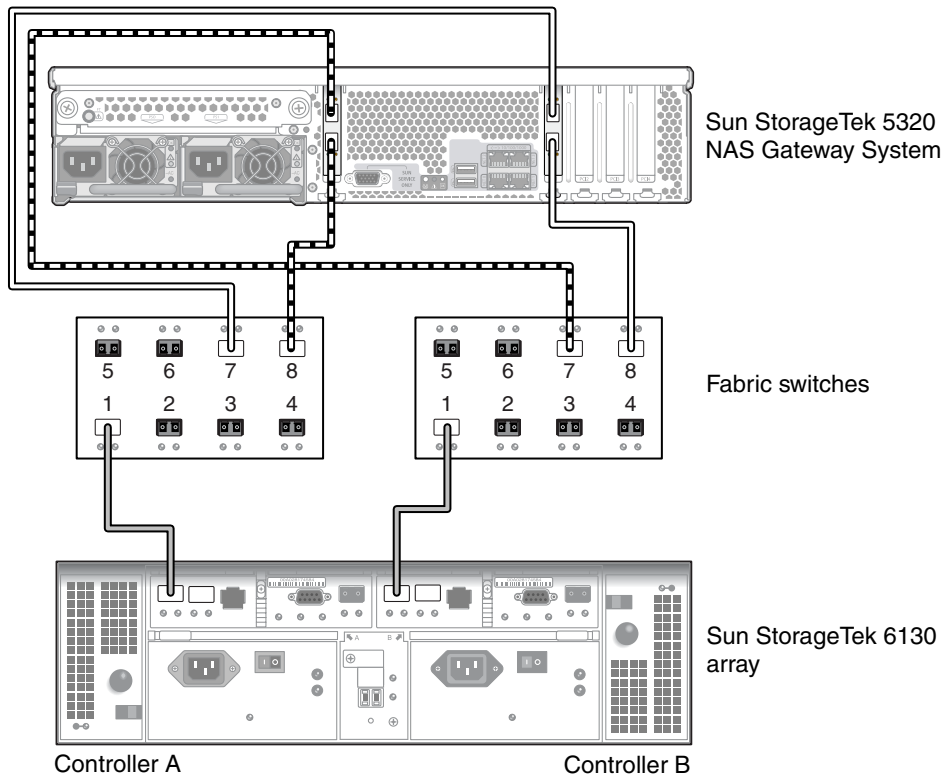

▼ To Connect a Dual-Server High-Availability Fabric Attach to the Sun StorageTek 6130/6140/6540 Array

You can connect a dual-server high-availability Sun StorageTek 5320 NAS Cluster Gateway System to SAN storage with two or four pairs of optical fiber cables, with or without additional switch connections. Using four pairs to connect all HBA ports ensures redundancy and improves processing speed.

1. Connect the HBA Port 1 of the first HBA card (PCI1) in the server H1 to the first available port of the first fabric switch.
2. Connect the HBA Port 1 of the second HBA card (PCI0) in the server H1 to the first available port of the second fabric switch.
3. Connect the HBA Port 1 of the first HBA card in the server H2 to the next available port of the first fabric switch.
4. Connect the HBA Port 1 of the second HBA card in the server H2 to the next available port of the second fabric switch.
5. Connect an available port on the first switch to the Controller A host 1 port on the Sun StorageTek 6130/6140/6540 array.
6. Connect an available port on the second switch to the Controller B host 1 port on the Sun StorageTek 6130/6140/6540 array.

FIGURE 5-9 Connecting Two HBA Ports per HA Server Through Fabric Switches to the Sun StorageTek 6130/6140/6540 Array

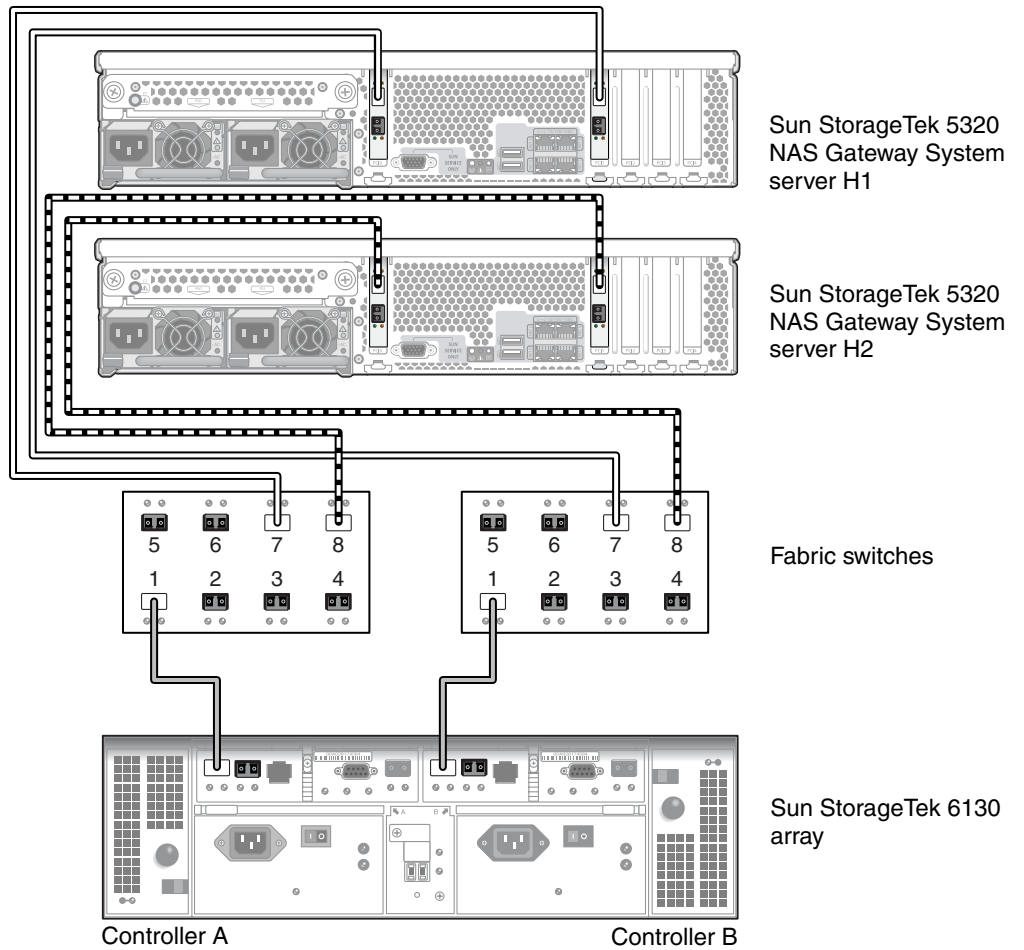

Connecting the Gateway System to the Sun StorageTek FlexLine 200 and 300 Series

This section describes how to cable the Sun StorageTek 5320 NAS Gateway System directly or through fabric switches to the Sun StorageTek FlexLine 200 and 300 series systems:

- [“Connecting Directly to the FlexLine 200 and 300 Series” on page 126](#)
- [“Using Fabric Switches to Connect to the Sun StorageTek FlexLine 200 and 300 Series” on page 128](#)

After connecting the systems, proceed to [“Connecting to the Network” on page 154](#).

Note – All figures in this section show the FlexLine 380 system. Cabling for the FlexLine 240 and FlexLine 280 is similar to the 380.

Connecting Directly to the FlexLine 200 and 300 Series

You can direct connect a single server or a dual server to the Sun StorageTek FlexLine series array.

▼ To Connect a Single-Server Direct Attach to the Sun StorageTek FlexLine 200 and 300 Series

You can connect to SAN storage with one or two pairs of optical fiber cables. Using two pairs to connect all HBA ports ensures redundancy and improves processing speed.

1. **Connect the HBA Port 1 of the first HBA card (PCI1) to the first available port on the Sun StorageTek FlexLine 200 and 300 series.**
2. **Connect the HBA Port 1 of the second HBA card (PCI0) to the next available port on the Sun StorageTek FlexLine 380 system.**

FIGURE 5-10 Connecting Two HBA Ports to the Sun StorageTek FlexLine Array

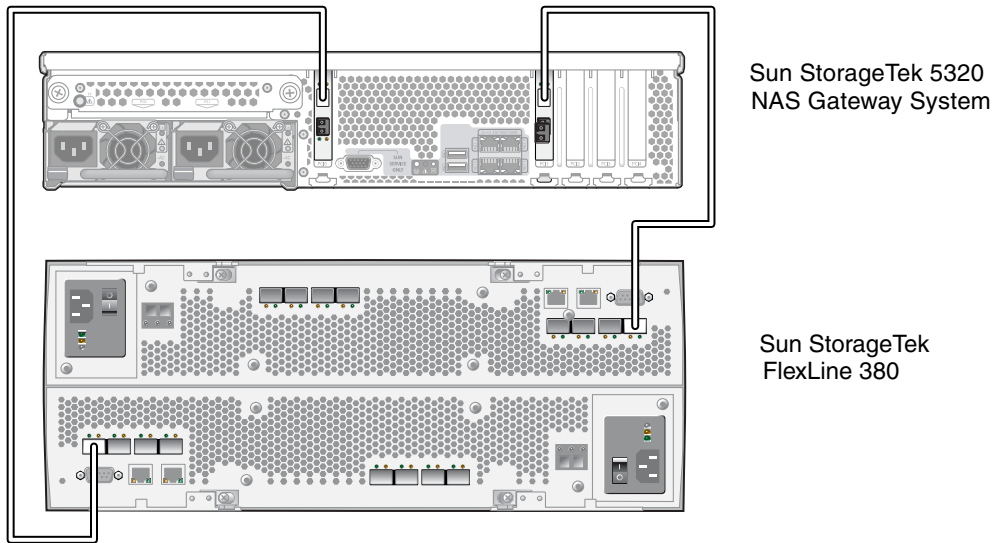

▼ To Connect a Dual-Server Direct Attach to the Sun StorageTek FlexLine 200 and 300 Series

You can connect a dual-server high-availability (HA) Sun StorageTek 5320 NAS Cluster Gateway System to SAN storage with two or four pairs of optical fiber cables. Using four pairs to connect all HBA ports simulates a dual array, ensures redundancy, and improves processing speed.

1. Connect the HBA Port 1 of the first HBA card (PCI1) on server H1 to the first available port on the Sun StorageTek FlexLine 200 and 300 series.
2. Connect the HBA Port 1 of the second HBA card (PCI0) on server H1 to the next available port on the Sun StorageTek FlexLine 200 and 300 series.
3. Connect the HBA Port 1 of the first HBA card on server H2 to the next available port on the Sun StorageTek FlexLine 200 and 300 series.
4. Connect the HBA Port 1 of the second HBA card on server H2 to the next available port on the Sun StorageTek FlexLine 200 and 300 series.

FIGURE 5-11 Connecting Two HBA Ports per HA Server to the Sun StorageTek FlexLine Array

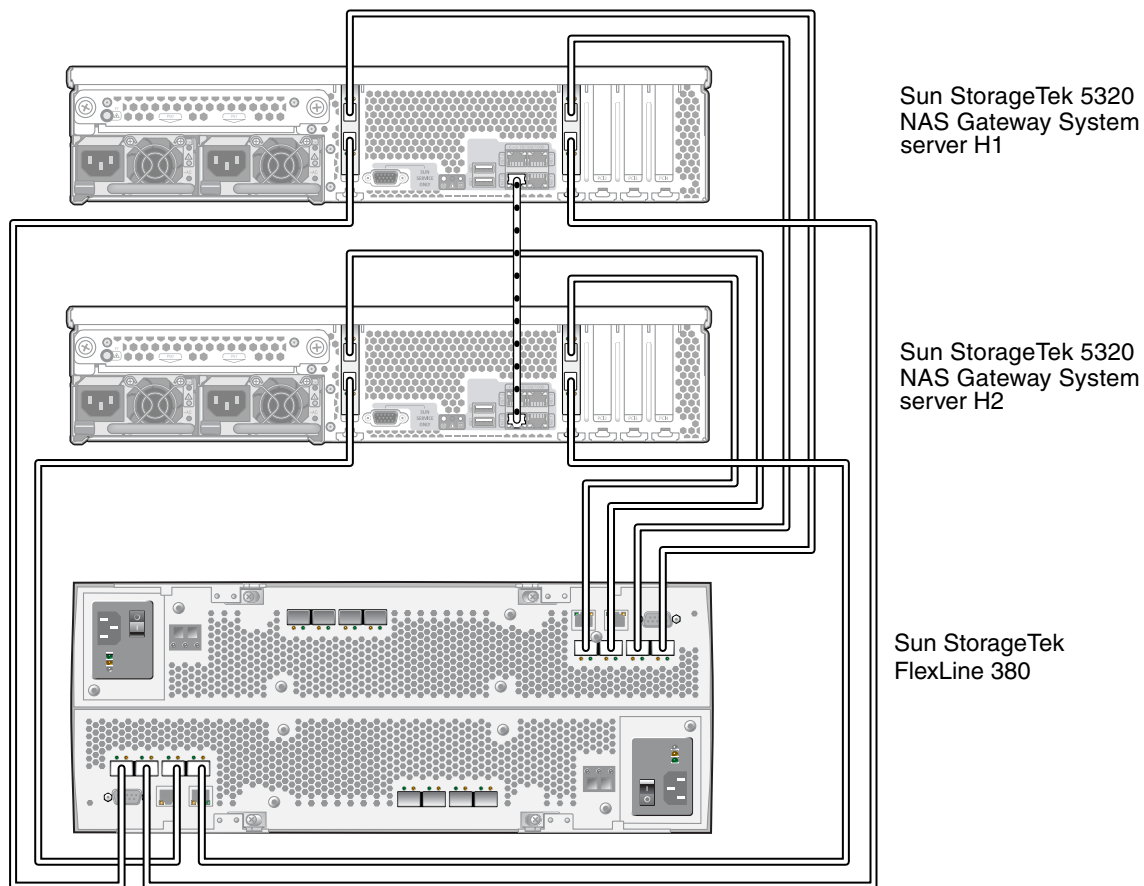

Using Fabric Switches to Connect to the Sun StorageTek FlexLine 200 and 300 Series

The following fabric attach configurations are described in this section:

- [“To Connect a Single-Server Fabric Attach to the Sun StorageTek FlexLine 200 and 300 Series”](#) on page 129
- [“To Connect a Dual-Server High-Availability Fabric Attach to the Sun StorageTek FlexLine 200 and 300 Series”](#) on page 130

Note – Do not power on the server until instructed in [“Powering On the Gateway System”](#) on page 156.

Configure zoning of the FC switch so that a single host bus adapter (HBA) can access only one port (often referred to as "one-to-one" zoning). When necessary, you can also configure "overlapping" zones. Refer to your fabric switch documentation for additional information about zoning configuration.

▼ To Connect a Single-Server Fabric Attach to the Sun StorageTek FlexLine 200 and 300 Series

You can connect to SAN storage with one or two pairs of optical fiber cables. Using two pairs to connect all HBA ports and using two switches ensures redundancy and improves processing speed.

- 1. Connect the HBA Port 1 of the first HBA card (PCI1) to the first available port of the first fabric switch.**
- 2. Connect the HBA Port 1 of the second HBA card (PCI0) to the first available port of the second fabric switch.**
- 3. Connect an available port on the first switch to the Controller A host 1 port on the Sun StorageTek FlexLine 200 and 300 series.**
- 4. Connect an available port on the second switch to the Controller B host 1 port on the Sun StorageTek FlexLine 200 and 300 series.**

FIGURE 5-12 Connecting Two HBA Ports Using Fabric Switches to the Sun StorageTek FlexLine Array

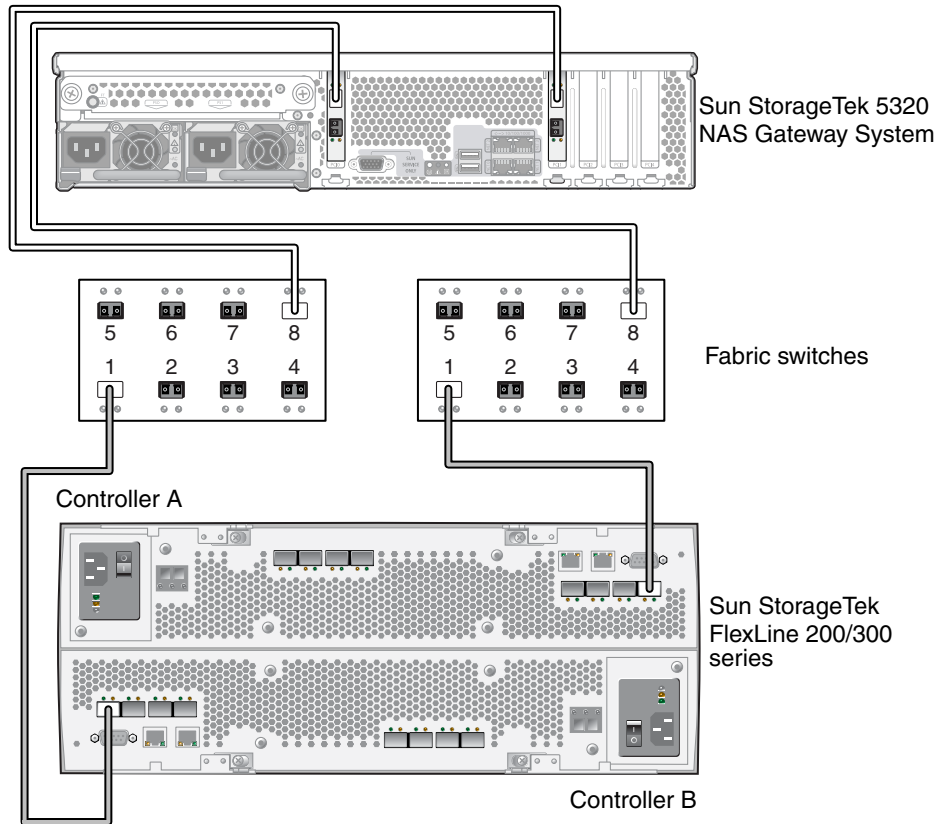

▼ To Connect a Dual-Server High-Availability Fabric Attach to the Sun StorageTek FlexLine 200 and 300 Series

You can connect a dual-server high-availability Sun StorageTek 5320 NAS Cluster Gateway System to SAN storage with two or four pairs of optical fiber cables, with or without additional switch connections. Using four pairs to connect all HBA ports ensures redundancy and improves processing speed.

1. **Connect the HBA Port 1 of the first HBA card (PCI1) in the server H1 to the first available port of the first fabric switch.**
2. **Connect the HBA Port 1 of the second HBA card (PCI0) in the server H1 to the first available port of the second fabric switch.**

3. **Connect the HBA Port 1 of the first HBA card in the server H2 to the next available port of the first fabric switch.**
4. **Connect the HBA Port 1 of the second HBA card in the server H2 to the next available port of the second fabric switch.**
5. **Connect an available port on the first switch to the Controller A host 1 port on the Sun StorageTek FlexLine 200 and 300 series.**
6. **Connect an available port on the second switch to the Controller B host 1 port on the Sun StorageTek FlexLine 200 and 300 series.**

FIGURE 5-13 Connecting Two HBA Ports per HA Server Through Fabric Switches to the Sun StorageTek FlexLine Array

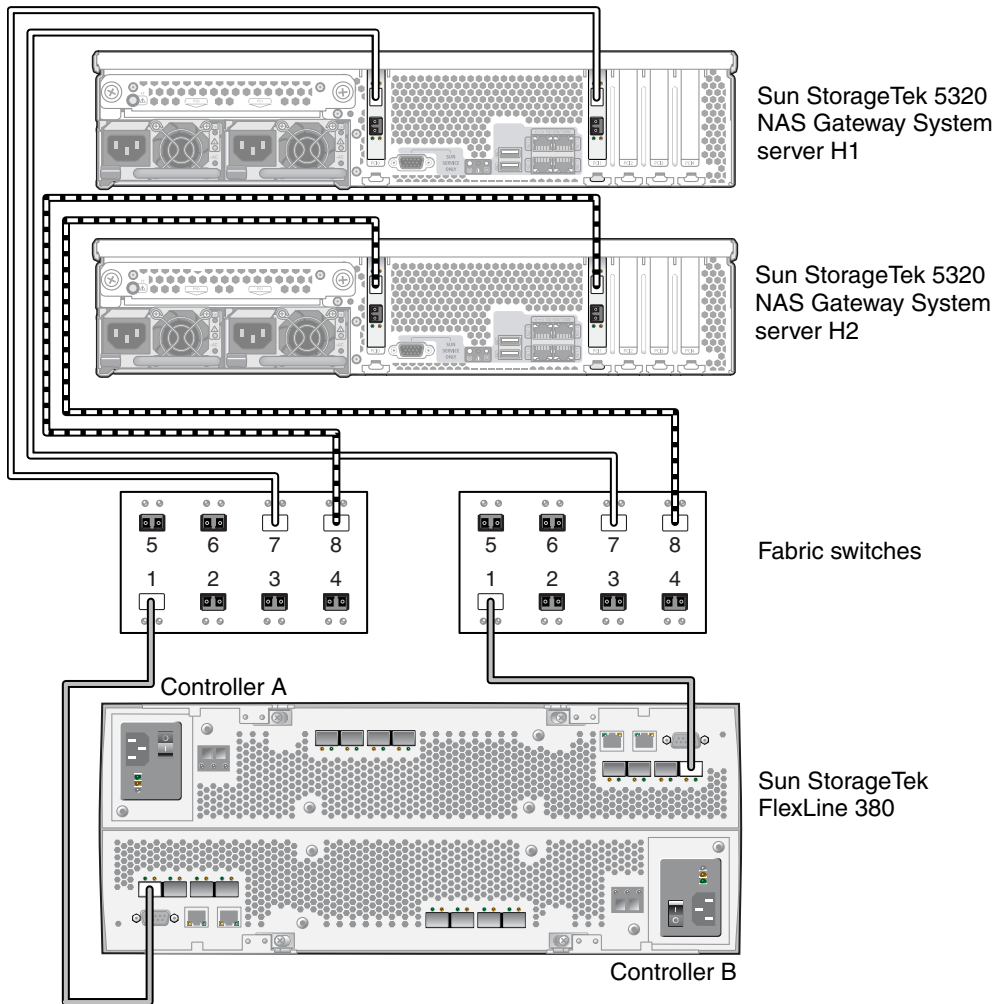

7. (Optional) For additional redundancy, attach additional cables from the two switches:

- a. Connect the next available port on the first switch to the Controller B host 2 port on the Sun StorageTek FlexLine 200 and 300 series.
- b. Connect the next available port on the second switch to the Controller A host 2 port on the Sun StorageTek FlexLine 200 and 300 series.

FIGURE 5-14 Connecting Two HBA Ports per HA Server Through Fabric Switches to the Sun StorageTek FlexLine With Additional Switch Connections

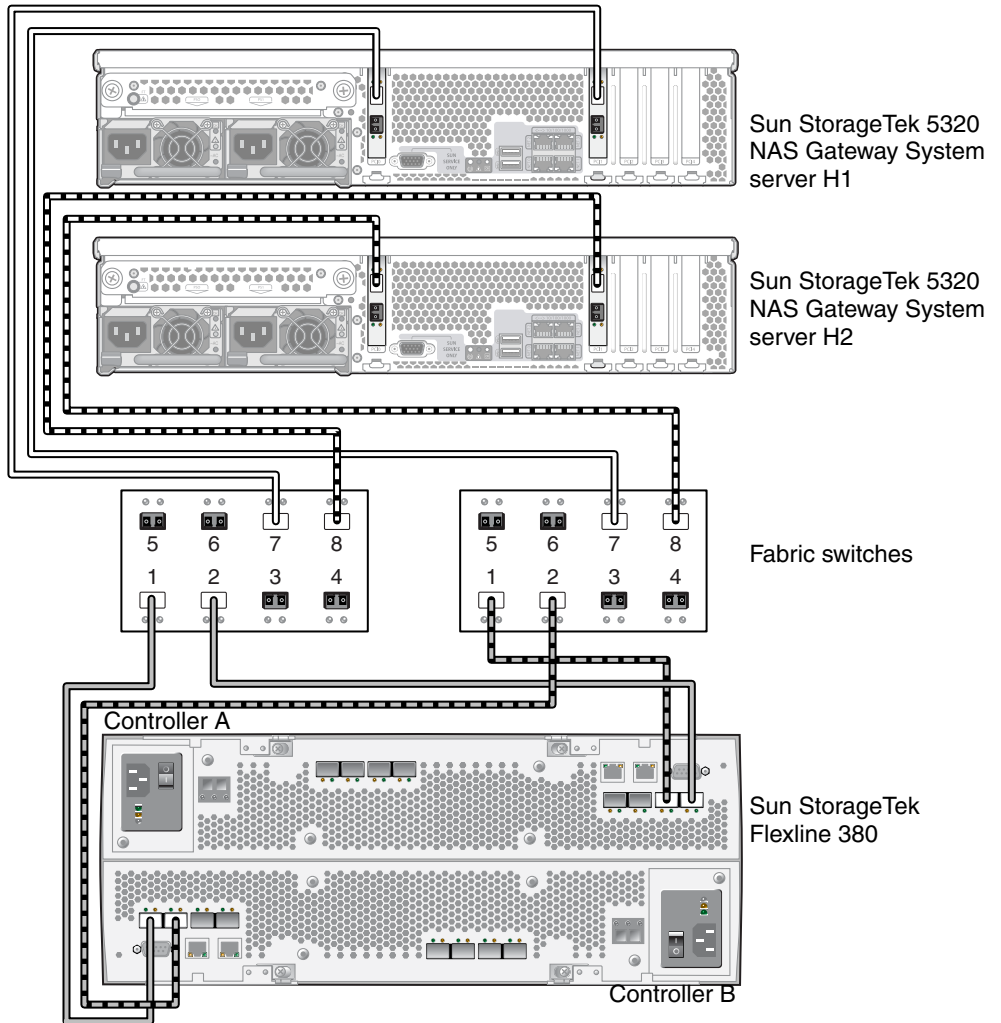

Sun StorageTek FlexLine 200 and 300 Series Gateway Configuration

To use the Sun StorageTek FlexLine 200 and 300 series array for Sun StorageTek 5320 NAS Gateway System storage, the host type parameter of both controller A and controller B on the FlexLine series array must be set to SE_5xxx. The SE_5xxx host type option is available on the FlexLine series array only if it is running NVSRAM version N6091-616843-005 or later.

If the FlexLine series array is not running this version of NVSRAM, you need to either upgrade to this NVSRAM version or run two scripts to add the NAS host type region.

The two scripts (CtrlAModReg12 and CtrlBModReg12) are available in patch number 124128-01 on <http://sunsolve.sun.com>. The two scripts are available in patch number 124128-01 on <http://sunsolve.sun.com>. You must have a valid service contract in order to access the patch.

Modifying the Host Type on the Sun StorageTek FlexLine 200 and 300 Series Array

Note – If you are running NVSRAM N6091-616843-005, you do not need to perform this procedure.

1. Verify that host type region 12 is not in use by opening the SANtricity Storage Manager and go to Storage System > View > Profile > Mappings. If host type region 12 is already in use by a valid host type, you need to modify the scripts. See “Changing the Host Type Region on the Scripts” on page 135 for more information.
2. Select the Patchfinder link on <http://sunsolve.sun.com>, and enter patch number 124128-01 to download the patch.
3. Extract the scripts CtrlAModReg12 and CtrlBModReg12 from the patch.
4. Run the script CtrlAModRegion12 to update the host type parameter on controller A:

```
# SMcli IP_address_controller_A -f CtrlAModRegion12
```
5. Run the script CtrlBModRegion12 to update the host type parameter on controller B:

```
# SMcli IP_address_controller_B -f CtrlBModRegion12
```
6. # SMcli IP_address_controller_B -f CtrlBModRegion12Reset controller A:

```
# SMcli IP_address_controller_A -c "reset controller [a];"
```

7. Reset controller B:

```
# SMcli IP_address_controller_B -c "reset controller [b];"
```

- 8. Verify that the host type has been changed to SE_5xxx by opening the SANtricity Storage Manager and go to Storage System > View > Profile > Mappings.**

Changing the Host Type Region on the Scripts

Do not upgrade to NVSRAM N6091-616843-005 if host type region 12 is already in use. If the host type region 12 is currently in use, you need to modify the scripts before running them.

To edit the scripts to change the host type region:

1. Download the patch as described in [Step 2](#) of the previous procedure.
2. Open the scripts `CtrlAModReg12` and `CtrlBModReg12` in the SMcli.
3. Replace the index number of 12 with the index number of the host type region you need to modify.
4. Continue with step 3 in [“Modifying the Host Type on the Sun StorageTek FlexLine 200 and 300 Series Array”](#) on page 134.

Connecting the Sun StorageTek 5320 NAS Gateway System to the Sun StorEdge 6920 System

This section describes how to cable the Sun StorageTek 5320 NAS Gateway System directly or through fabric switches to the Sun StorEdge 6920 system:

- [“Using Fabric Switches to Connect to the Sun StorEdge 6920 System”](#) on page 139
- After connecting the systems, proceed to [“Connecting to the Network”](#) on page 154.

Connecting Directly to the Sun StorEdge 6920 System

The following direct attach configurations are described in this section:

- [“To Connect a Single-Server Direct Attach to the Sun StorEdge 6920 System” on page 136](#)
- [“To Connect a Dual-Server Direct Attach to the Sun StorEdge 6920 System” on page 137](#)

Note – Do not power on the server until instructed in [“Powering On the Gateway System” on page 156](#).

▼ To Connect a Single-Server Direct Attach to the Sun StorEdge 6920 System

You can connect to SAN storage with one or two pairs of optical fiber cables. Using two pairs to connect all HBA ports ensures redundancy and improves processing speed.

1. **Connect the HBA Port 1 of the first HBA card (PCI1) to the first available port on the Sun StorEdge 6920 system.**
2. **Connect the HBA Port 1 of the second HBA card (PCI0) to the next available port on the Sun StorEdge 6920 system.**

FIGURE 5-15 Connecting Two HBA Ports to the Sun StorEdge 6920 System

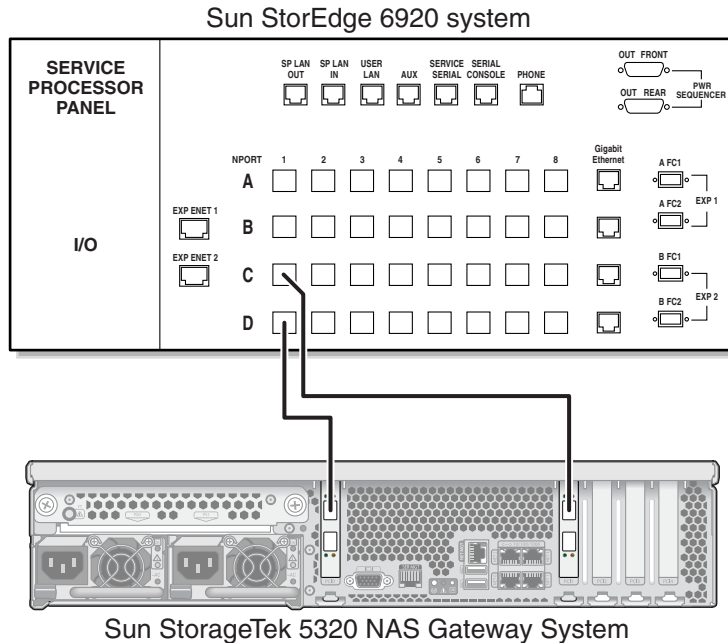

▼ To Connect a Dual-Server Direct Attach to the Sun StorEdge 6920 System

You can connect a dual-server high-availability (HA) Sun StorageTek 5320 NAS Cluster Gateway System to SAN storage with two or four pairs of optical fiber cables. Using four pairs to connect all HBA ports simulates a dual array, ensures redundancy, and improves processing speed.

1. Connect the HBA Port 1 of the first HBA card (PCI1) on server H1 to the first available port on the Sun StorEdge 6920 system.
2. Connect the HBA Port 1 of the second HBA card (PCI0) on server H1 to the next available port on the Sun StorEdge 6920 system.
3. Connect the HBA Port 1 of the first HBA card on server H2 to the next available port on the Sun StorEdge 6920 system.
4. Connect the HBA Port 1 of the second HBA card on server H2 to the next available port on the Sun StorEdge 6920 system.

FIGURE 5-16 Connecting Two HBA Ports per HA Server to the Sun StorEdge 6920 System

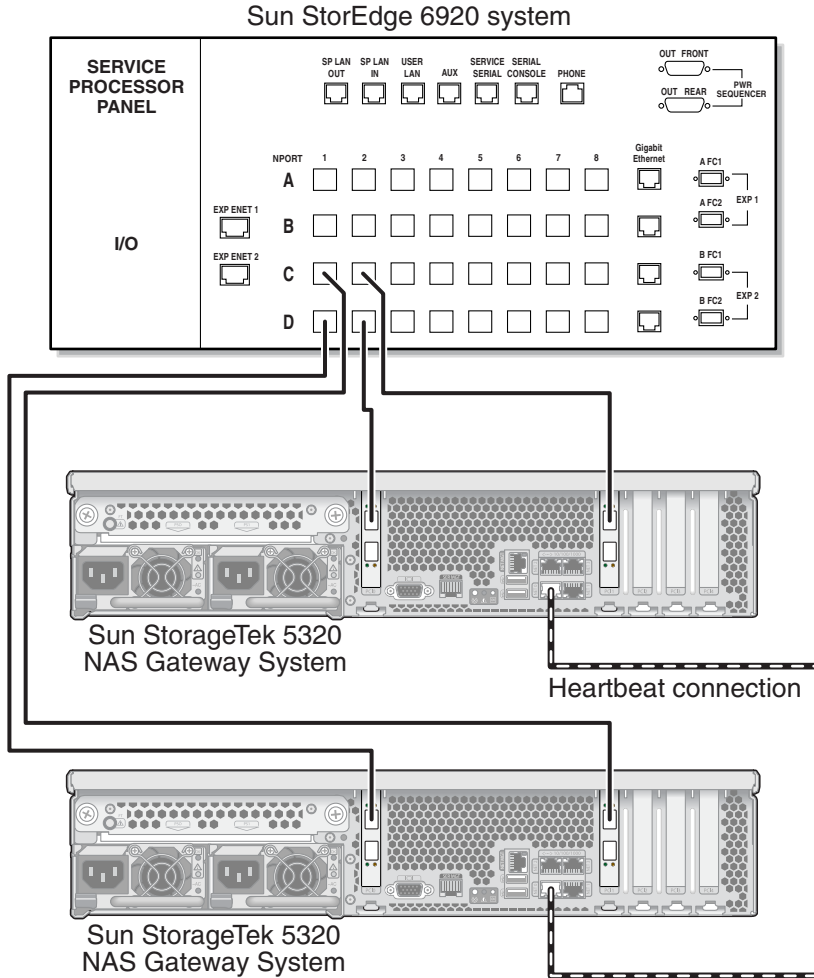

Using Fabric Switches to Connect to the Sun StorEdge 6920 System

The following fabric attach configurations are described in this section:

- [“To Connect a Single-Server Fabric Attach to the Sun StorEdge 6920 System”](#) on page 139
- [“To Connect Dual-Server High-Availability Fabric Attach to the Sun StorageTek 6920 System”](#) on page 140

Note – Do not power on the server until instructed in [“Powering On the Gateway System”](#) on page 156.

▼ To Connect a Single-Server Fabric Attach to the Sun StorEdge 6920 System

You can connect to SAN storage with one or two pairs of optical fiber cables. Using two pairs to connect all HBA ports and using two switches ensures redundancy and improves processing speed.

1. **Connect the HBA Port 1 of the first HBA card (PCI1) to the first available port of the first fabric switch.**
2. **Connect the HBA Port 1 of the second HBA card (PCI0) to the first available port of the second fabric switch.**
3. **Connect an available port on the first switch to the first available port on the Sun StorEdge 6920 system.**
4. **Connect an available port on the second switch to the next available port on the Sun StorEdge 6920 system.**

FIGURE 5-17 Connecting Two HBA Ports Using Fabric Switches to the Sun StorEdge 6920 System

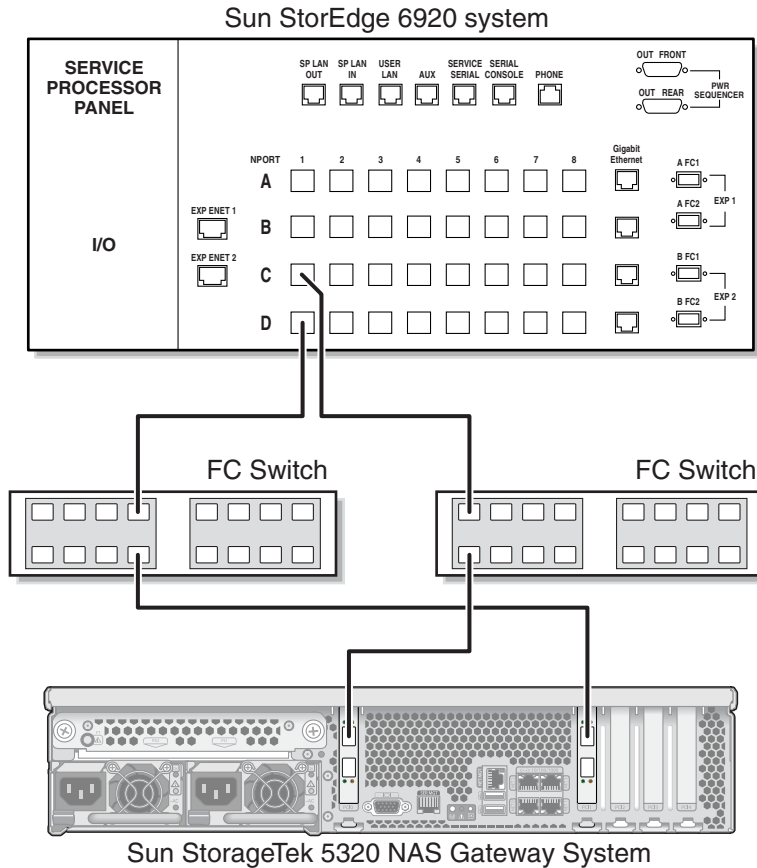

▼ To Connect Dual-Server High-Availability Fabric Attach to the Sun StorageTek 6920 System

You can connect a dual-server high-availability Sun StorageTek 5320 NAS Cluster Gateway System to SAN storage with two or four pairs of optical fiber cables, with or without additional switch connections. Using four pairs to connect all HBA ports ensures redundancy and improves processing speed.

1. Connect the HBA Port 1 of the first HBA card (PCI1) in the server H1 to the first available port of the first fabric switch.
2. Connect the HBA Port 1 of the second HBA card (PCI0) in the server H1 to the first available port of the second fabric switch.

3. **Connect the HBA Port 1 of the first HBA card in the server H2 to the next available port of the first fabric switch.**
4. **Connect the HBA Port 1 of the second HBA card in the server H2 to the next available port of the second fabric switch.**
5. **Connect an available port on the first switch to the first available port on the Sun StorEdge 6920 system.**
6. **Connect an available port on the second switch to the next available port on the Sun StorEdge 6920 system.**

FIGURE 5-18 Connecting Two HBA Ports per HA Server Through Fabric Switches to the Sun StorEdge 6920 System

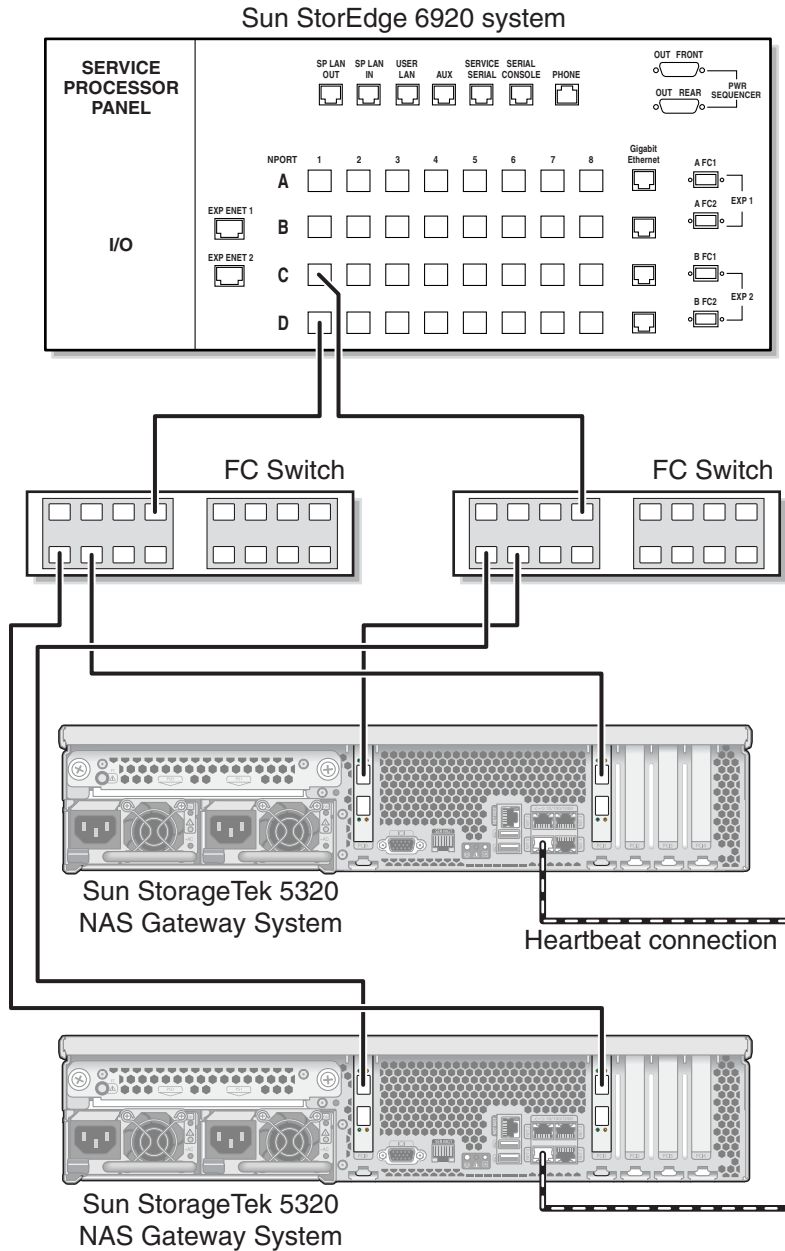

7. (Optional) To enable all LUNs to be shared between all port pairs, attach additional cables from the two switches:

- a. **Connect the next available port on the first switch to the next available port on the Sun StorEdge 6920 system.**
- b. **Connect the next available port on the second switch to the next available port on the Sun StorEdge 6920 system.**

FIGURE 5-19 Connecting Two HBA Ports per HA Server Through Fabric Switches to the Sun StorEdge 6920 System With Additional Switch Connections

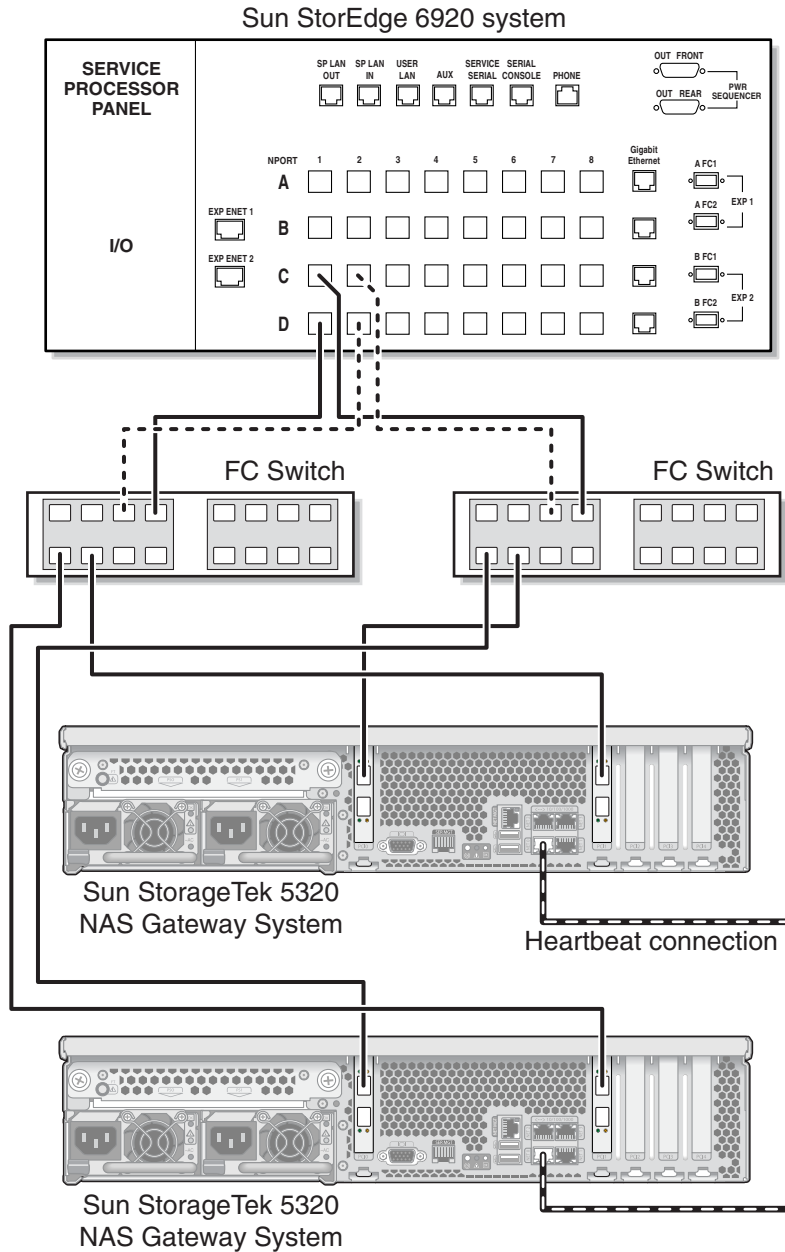

Connecting the Gateway System or Gateway Cluster System to the Sun StorEdge 99xx System

This section describes how to cable the Sun StorageTek 5320 NAS Gateway System or NAS Gateway Cluster System directly or through fabric switches to the Sun StorEdge 99xx system:

- [“Connecting Directly to the Sun StorEdge 99xx System” on page 145](#)
- [“Using Fabric Switches to Connect to the Sun StorEdge 99xx System” on page 148](#)
After connecting the systems, proceed to [“Connecting to the Network” on page 154](#).

Connecting Directly to the Sun StorEdge 99xx System

The following direct attach configurations are described in this section:

- [“To Connect a Single-Server Direct Attach to the Sun StorEdge 99xx System” on page 145](#)
- [“To Connect a Dual-Server Direct Attach to the Sun StorEdge 99xx System” on page 146](#)

Note – Do not power on the server until instructed in [“Powering On the Gateway System” on page 156](#).

▼ To Connect a Single-Server Direct Attach to the Sun StorEdge 99xx System

You can connect to SAN storage with one or two pairs of optical fiber cables. Using two pairs to connect all HBA ports ensures redundancy and improves processing speed.

1. **Connect the HBA Port 1 of the first HBA card (PCI1) to the first available port on the Sun StorEdge 99xx system.**

2. Connect the HBA Port 1 of the second HBA card (PCI0) to the next available port on the Sun StorEdge 99xx system.

FIGURE 5-20 Connecting Two HBA Ports to the Sun StorEdge 99xx System

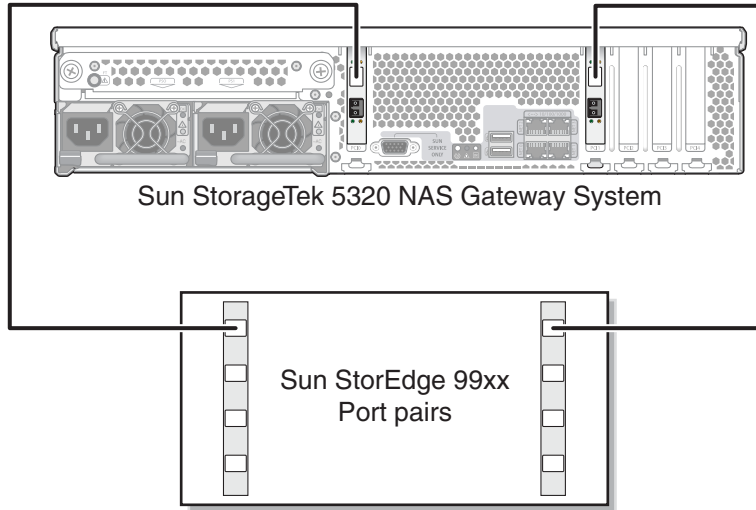

▼ To Connect a Dual-Server Direct Attach to the Sun StorEdge 99xx System

You can connect a dual-server high-availability (HA) Sun StorageTek 5320 NAS Cluster Gateway System to SAN storage with two or four pairs of optical fiber cables. Using four pairs to connect all HBA ports simulates a dual array, ensures redundancy, and improves processing speed.

1. Connect the HBA Port 1 of the first HBA card (PCI1) on server H1 to the first available port on the Sun StorEdge 99xx system.
2. Connect the HBA Port 1 of the second HBA card (PCI0) on server H1 to the next available port on the Sun StorEdge 99xx system.
3. Connect the HBA Port 1 of the first HBA card on server H2 to the next available port on the Sun StorEdge 99xx system. Connect the HBA Port 1 of the second HBA card on server H2 to the next available port on the Sun StorEdge 99xx system.

FIGURE 5-21 Connecting Two HBA Ports per HA Server to the Sun StorEdge 99xx System

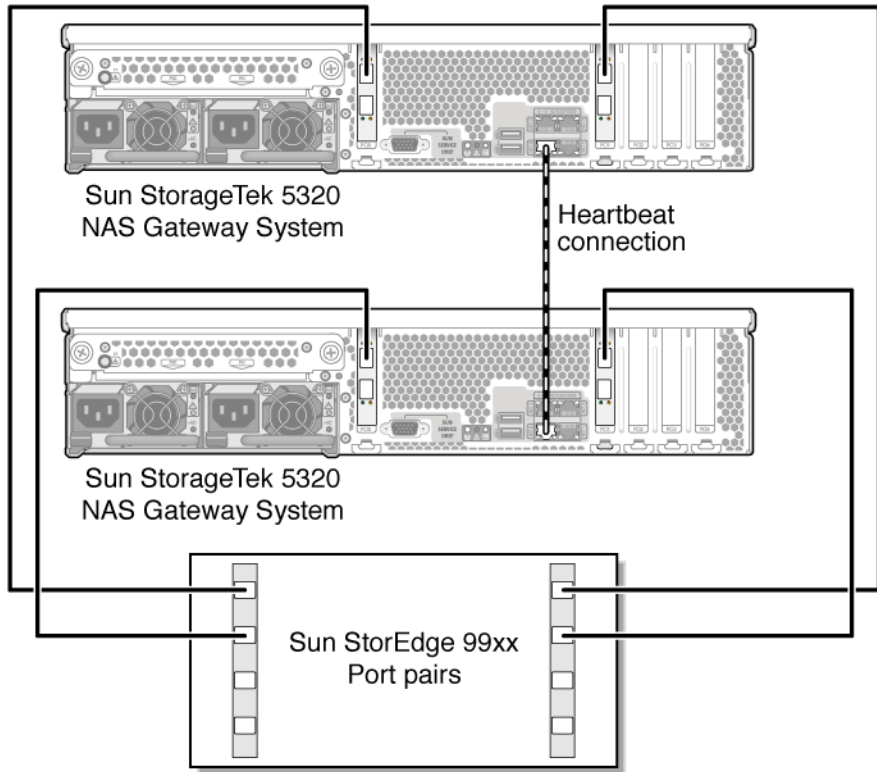

Using Fabric Switches to Connect to the Sun StorEdge 99xx System

The following fabric attach configurations are described in this section:

- [“To Connect a Single-Server Fabric Attach to the Sun StorEdge 99xx System” on page 148](#)
- [“To Connect an Independent Dual-Server Fabric Attach to the Sun StorEdge 99xx System” on page 149](#)
- [“To Connect a Dual-Server High-Availability Fabric Attach to the Sun StorEdge 99xx System” on page 151](#)

Note – Do not power on the server until instructed in [“Powering On the Gateway System” on page 156](#).

▼ To Connect a Single-Server Fabric Attach to the Sun StorEdge 99xx System

You can connect to SAN storage with one or two pairs of optical fiber cables. Using two pairs to connect all HBA ports and using two switches ensures redundancy and improves processing speed.

1. **Connect the HBA Port 1 of the first HBA card (PCI1) to the first available port of the first fabric switch.**
2. **Connect the HBA Port 1 of the second HBA card (PCI0) to the first available port of the second fabric switch.**
3. **Connect an available port on the first switch to the first available port on the Sun StorEdge 99xx system.**
4. **Connect an available port on the second switch to the next available port on the Sun StorEdge 99xx system.**

FIGURE 5-22 Connecting Two HBA Ports Through Fabric Switches to the Sun StorEdge 99xx System

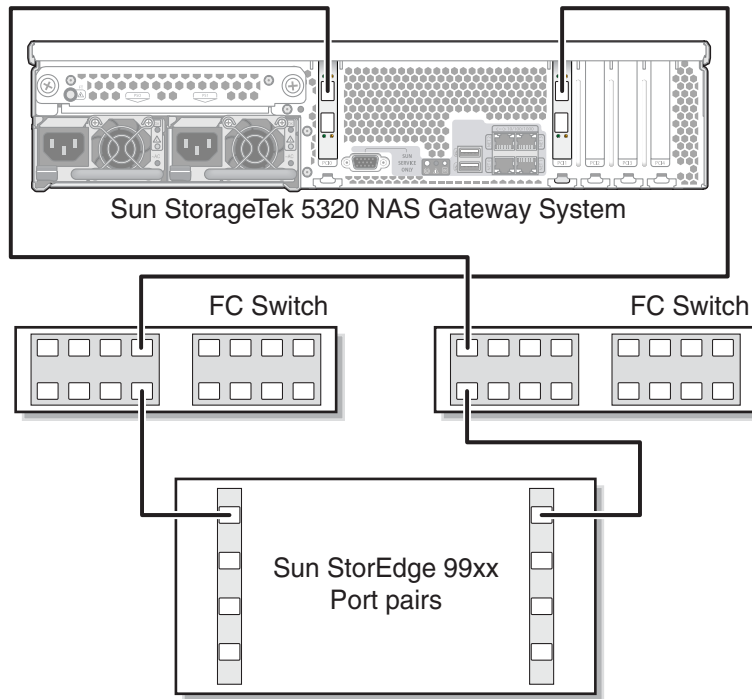

▼ To Connect an Independent Dual-Server Fabric Attach to the Sun StorEdge 99xx System

You can connect two independent (not high-availability) Sun StorageTek 5320 NAS Gateway System servers.

1. Connect the HBA Port 1 of the first HBA card (PCI1) in the first server to the first available port of the first fabric switch.
2. Connect the HBA Port 1 of the second HBA card (PCI0) in the first server to the first available port of the second fabric switch.
3. Connect the HBA Port 1 of the first HBA card in the second server to the next available port of the first fabric switch.
4. Connect the HBA Port 1 of the second HBA card in the second server to the next available port of the second fabric switch.

5. Connect an available port on the first switch to the first available port on the Sun StorEdge 99xx system.
6. Connect an available port on the second switch to the next available port on the Sun StorEdge 99xx system.

FIGURE 5-23 Connecting Two HBA Ports per Independent Server Through Fabric Switches to the Sun StorEdge 99xx System

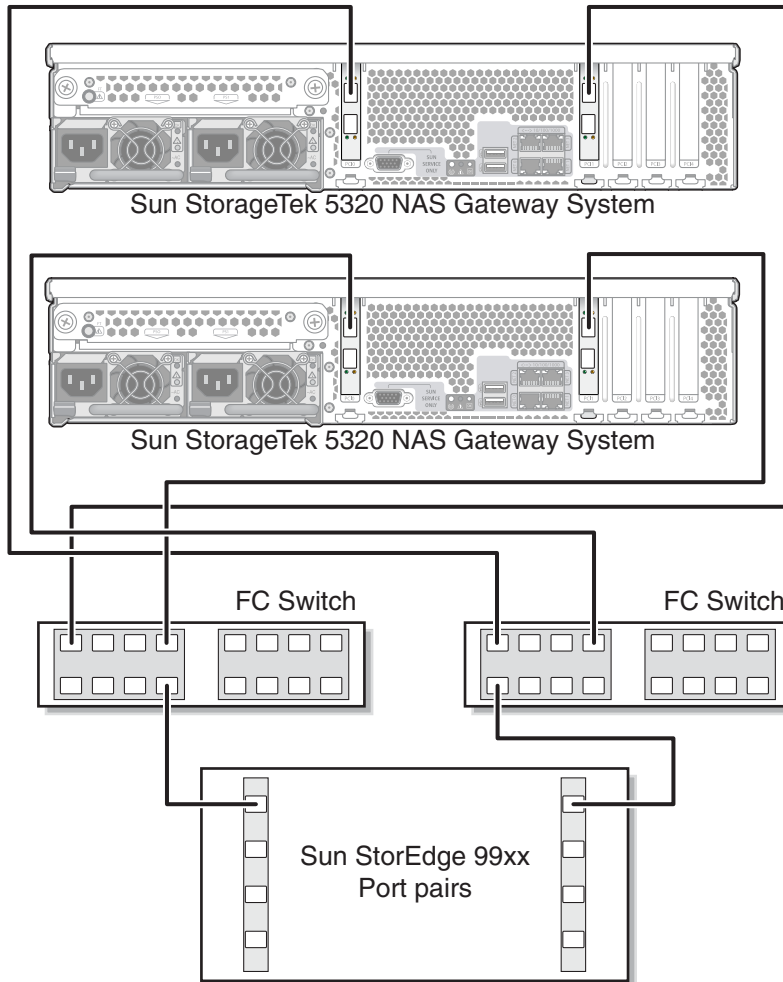

▼ To Connect a Dual-Server High-Availability Fabric Attach to the Sun StorEdge 99xx System

You can connect a dual-server high-availability Sun StorageTek 5320 NAS Cluster Gateway System to SAN storage with two or four pairs of optical fiber cables, with or without additional switch connections. Using four pairs to connect all HBA ports ensures redundancy and improves processing speed.

1. **Connect the HBA Port 1 of the first HBA card (PCI1) in the server H1 to the first available port of the first fabric switch.**
2. **Connect the HBA Port 1 of the second HBA card (PCI0) in the server H1 to the first available port of the second fabric switch.**
3. **Connect the HBA Port 1 of the first HBA card in the server H2 to the next available port of the first fabric switch.**
4. **Connect the HBA Port 1 of the second HBA card in the server H2 to the next available port of the second fabric switch.**
5. **Connect an available port on the first switch to the first available port on the Sun StorEdge 99xx system.**
6. **Connect an available port on the second switch to the next available port on the Sun StorEdge 99xx system.**

FIGURE 5-24 Connecting Two HBA Ports per HA Server Through Fabric Switches to the Sun StorEdge 99xx System

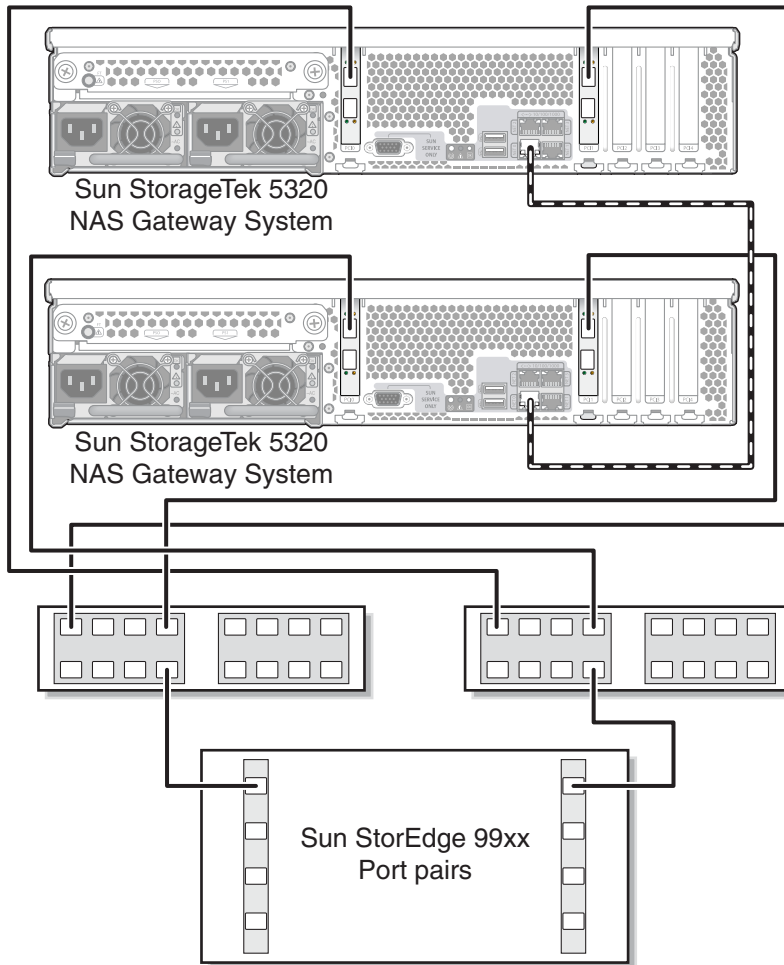

7. (Optional) To enable all LUNs to be shared between all port pairs, attach additional cables from the two switches:
 - a. Connect the next available port on the first switch to the next available port on the Sun StorEdge 99xx system.
 - b. Connect the next available port on the second switch to the next available port on the Sun StorEdge 99xx system.

FIGURE 5-25 Connecting Two HBA Ports per HA Server Through Fabric Switches to the Sun StorEdge 99xx System With Additional Switch Connections

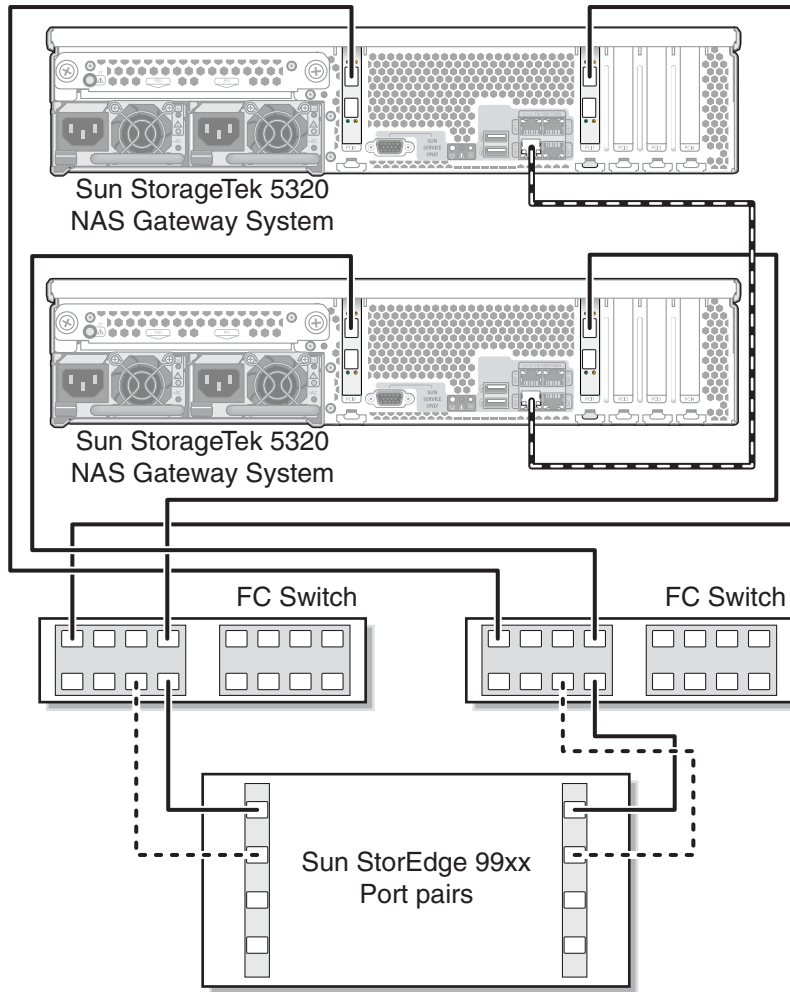

Connecting to the Network

The Sun StorageTek 5320 NAS Gateway System network connections depend on your system configuration. Each configuration is described in this section.

Connecting Single Servers

The available network connectors depend on your system configuration: Fast Ethernet or optical Gigabit Ethernet (optional card installation required).

▼ To Connect to a 100BASE-T Fast Ethernet Network or to a 1000BASE-T Gigabit Network

- Connect an RJ-45 unshielded twisted-pair cable from your local area network (LAN) to the port NET0 or the port NET1 on the back of the Sun StorageTek 5320 NAS Gateway System.

FIGURE 5-26 Connecting to a Fast Ethernet or a Gigabit Ethernet Network

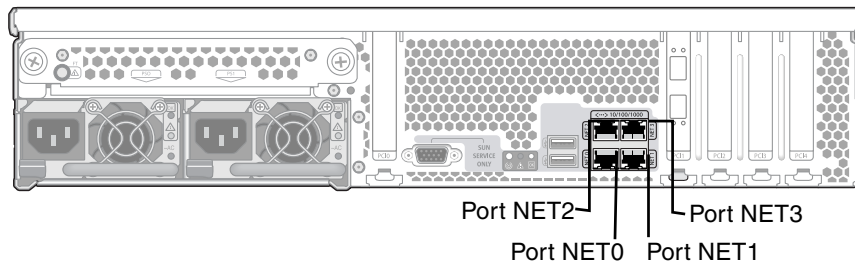

Note – Later, when you configure the system (see [“Initial Gateway System Single-Server Configuration”](#) on page 159), the NET0 port is displayed as “Port emc1” and the NET1 port is displayed as “Port emc2.”

▼ To Connect to an Optical Gigabit Ethernet Network

- Connect an optical network cable to the top (LINK A) optical gigabit Ethernet connector and another optical network cable to the bottom (LINK B) optical Gigabit Ethernet connector on the back of the Sun StorageTek 5320 NAS Gateway System.

FIGURE 5-27 Connecting to an Optical Gigabit Ethernet Network

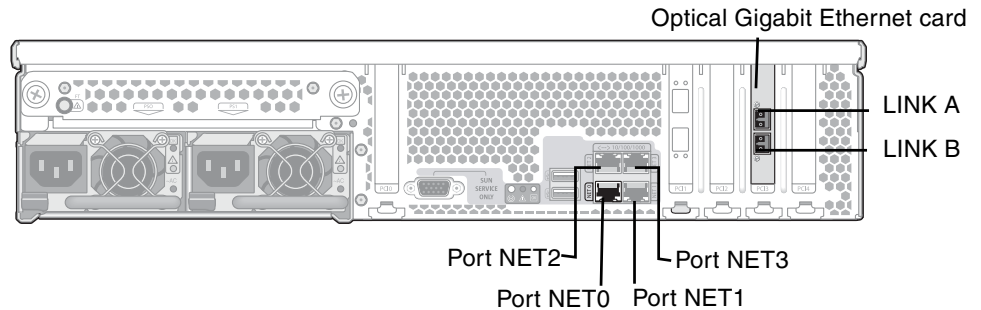

Note – Later, when you configure the system (see [“Initial Gateway System Single-Server Configuration”](#) on page 159), the LINK A port displays as “Port emf3” and the LINK B port displays as “Port emf4.”

Connecting Dual-Server HA Servers

Each server in a dual-server Sun StorageTek 5320 NAS Cluster Gateway System uses a dedicated Ethernet connection to communicate with its partner and perform periodic “health checks.” The port used for the health check connection is referred to as the *heartbeat port*. The NET0 Gigabit Ethernet port is used for the heartbeat.

The dual-server Sun StorageTek 5320 NAS Cluster Gateway System is commonly configured with four on-board copper gigabit ports and two dual-port Gigabit Ethernet cards (FIGURE 5-28).

FIGURE 5-28 Dual Server HA NIC Ports

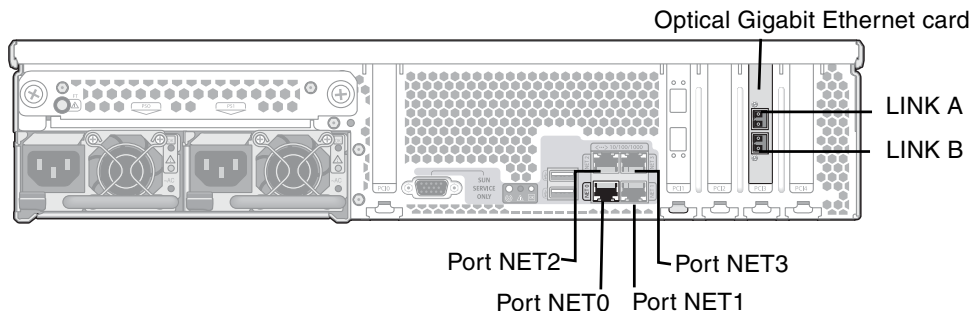

▼ To Connect the Health-Monitoring Cable

- Use an RJ-45 unshielded twisted-pair cable to connect the two servers' NET0 heartbeat ports.

▼ To Connect to a Fast Ethernet or Gigabit Ethernet Network

- Connect a Cat5 (for a 100BASE-T network) or Cat5e (for a 1000BASE-T network) Ethernet cable from your LAN to the NIC NET1, NET2, or NET3 port on the back of each of the servers (see [FIGURE 5-28](#) for NIC port locations).

▼ To Connect to an Optical Gigabit Ethernet Network

- Connect an optical network cable from the network to the top (LINK A) and connect another optical network cable from the network to the bottom (LINK B) optical Gigabit Ethernet connector on the back of each of the servers (see [FIGURE 5-28](#) for NIC and optical Gigabit Ethernet port locations).

Powering On the Gateway System

Before you proceed with initializing the system, you must power on the Sun StorageTek 5320 NAS Gateway System or NAS Gateway Cluster System.

▼ To Power On the Gateway System

1. **Verify that all cables between the Sun StorageTek 5320 NAS Gateway System and SAN storage have been connected.**

Refer to “Connecting the Sun StorageTek 5320 NAS Gateway System to the Sun StorageTek 6130/6140/6540 Array” on page 114, “Connecting the Sun StorageTek 5320 NAS Gateway System to the Sun StorEdge 6920 System” on page 135, or “Connecting the Gateway System or Gateway Cluster System to the Sun StorEdge 99xx System” on page 145.

2. **Verify that the Sun StorageTek 5320 NAS Gateway System is connected to the network.**

Refer to “Connecting to the Network” on page 154.

3. **For the Sun StorageTek 5320 NAS Cluster Gateway System dual-server configuration, verify that the health-monitoring cable is connected.**

Refer to “To Connect the Health-Monitoring Cable” on page 156.

4. **Using a pen tip or similar implement, press the recessed Power button (FIGURE 5-29).**

For the Sun StorageTek 5320 NAS Cluster Gateway System dual-server configuration, power on both servers.

FIGURE 5-29 Power Button and Front Panel Detail

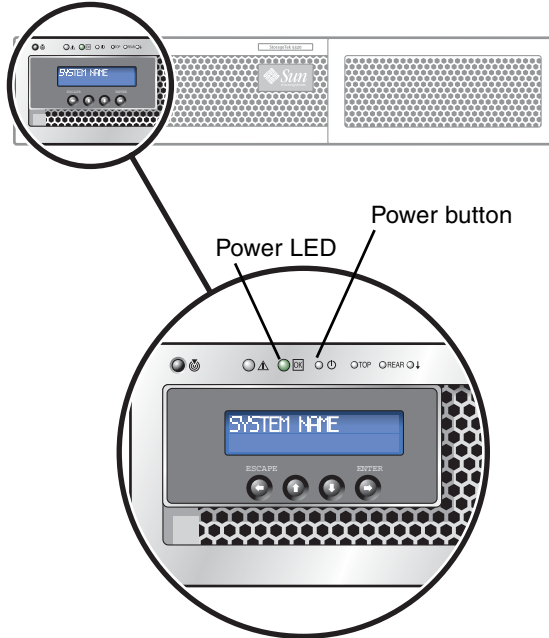

5. Wait for the system to boot up and display the menu on the LCD panel.

The NIC, System Status, and System ID LEDs should be green. On the back of the server, the link lights for the HBA ports should be green.

6. Proceed to the appropriate initial configuration instructions.

For the Sun StorageTek 5320 NAS Gateway System single-server configuration, refer to [“Initial Gateway System Single-Server Configuration”](#) on page 159.

For the Sun StorageTek 5320 NAS Cluster Gateway System configuration, refer to [“Initial Cluster Gateway System Configuration”](#) on page 166.

Initial Gateway System Single-Server Configuration

Note – These instructions apply to the Sun StorageTek 5320 NAS Gateway System single server only. For Sun StorageTek 5320 NAS Cluster Gateway System configuration instructions, refer to [“Initial Cluster Gateway System Configuration” on page 166](#). For Sun StorageTek 5320 NAS Appliance configuration instructions, refer to [Chapter 3](#).

To complete the initial Sun StorageTek 5320 NAS Gateway System configuration, you must specify the following:

- IP address
- Basic configuration information
- Storage and LUN configuration

▼ To Set the IP Address

If your network supports DHCP, an IP address is automatically assigned to your LAN port.

If DHCP is not available or you want to assign a static IP address, use the server’s LCD panel:

1. Select Menu.

2. Select A. Network Config.

3. Select A. Set Gateway and enter the gateway address.

To enter data, use the up and down arrow buttons to select digits, dots, or spaces. Then use the ENTER or right arrow button to accept each character.

4. Select C. Set Port-emx1 or C. Set Port-emx2 (depending on which port is the first regular LAN port) and enter the IP address, subnet mask, and broadcast address as prompted.

This IP address information is assigned to the first regular LAN port on your system.

5. Select Escape twice to return to the main menu.

Configuring the Single-Server System

To configure the system, you must set up basic system configuration and activate the license for the server.

Note – You must perform both tasks before proceeding to [“SAN Storage Configuration” on page 173](#).

▼ To Set Up Basic Configuration

1. **From a client on the same network, open a Java platform-enabled web browser with Java Plug-in and enter the IP address for the server.**
2. **Accept the “Applet Security Certificate” and wait until the Web Admin applet is loaded on this system.**
3. **On the Web Admin login screen, click Apply.**

The password can be set later. Refer to the *Sun StorageTek 5320 NAS OS Administration Guide*.

4. **On the Set Time and Date panel, select the date, the time, and the time zone, and click Apply. Then click Yes to confirm.**

This sets the secure clock to the same time and date. Make sure you set the time and date accurately as you can set the secure clock only once.

5. **Read the license agreement in the Configuration wizard dialog box, and click Accept to proceed with the following wizard steps:**
 - a. **Click Next in the Welcome dialog box.**
 - b. **From the Select Environment screen, configure Microsoft Windows, UNIX, or both environments, and click Next to continue.**
 - c. **From the Set Server Name screen, type the server name and populate the other fields accordingly, and then click Next.**
 - d. **On the Configure Network Adapters screen, verify that the information is correct, and click Next to continue.**

You can configure additional network interfaces at this time. However, if you change the configuration of the port to which the browser is attached, the browser session is disconnected.
 - e. **On the Set Gateway Address screen, verify that the address is correct, and, if not, type the gateway address. Click Next to continue.**
 - f. **If you are configuring a Windows environment:**

- i. Select **Domain or Workgroup**. To configure a Domain, type the name of the Windows 2000 domain where ADS is running, the user name, and password.
- ii. Select **Enable ADS** to enable Active Directory Service (ADS). In the **Container** field, type the ADS path location of the Windows user.

Note – Click the Help button if you need information about the fields on the Configure Domains and Workgroups screen.

The screenshot shows the 'Configure Domains and Workgroups' window. The 'Domain' radio button is selected. The 'Domain' field contains 'NASCLASS'. The 'User Name' and 'Password' fields are empty. The 'Enable ADS' checkbox is checked. The 'ADS Information' section has 'Container' set to 'ou=users' and 'Site' is empty. The 'Kerberos Domain Information' section has 'Realm' set to 'NASCLASS.COM' and 'Server' is empty. The 'Workgroup' radio button is unselected. The 'Name' field for the workgroup contains 'WORKGROUP' and the 'Comments' field is empty.

- iii. Click **Next** to continue.
- iv. To set up Windows Internet Naming Service (WINS), click **Enable WINS** on the **Set Up WINS** screen. If you need information about the fields on the **Set Up WINS** screen, click the **Help** button.
- g. On the **Set Up DNS** screen, click **Enable DNS** to set up the Domain Name Service (DNS). Click the **Help** button for information about the fields on this screen. Click **Next** to continue.

Note – When adding your DNS server, click **Add** item to list to ensure that the DNS server has been added.

- h. If you are configuring a UNIX environment, set up name services (NIS, NIS+, and NSSLDAP). Click the **Help** button for information about the fields on this screen. After filling in this screen, click **Next** to continue.

- i. On the **Set Up Email Notification** screen, enter the **Simple Mail Transport Protocol (SMTP)** server name and specify the recipients who should receive system notifications and warnings. Click **Next** to continue.
- j. On the **Set Up Logging** screen, to enable remote or local logging. Click **Help** for information about the fields on this screen. After filling in this screen, click **Next** to continue.
- k. On the **Set Time and Date** screen, set the server date and time. Click **Next** to continue.
- l. On the **Assign Language** screen, specify the language to display by the **Web Admin** application. Click **Next** to continue.
- m. On the **Online System Registration** screen, choose to **register now or later**. If you choose to **register now** complete the following:
 - a. Check the **Agree** box to agree to the terms in the **Disclaimer** box.
 - b. On the **Sun Account** tab, enter your **Sun Account ID** and password.
 - c. On the **Proxy Server** tab, enter your **HTTP proxy server name** and port number, **Proxy User Name**, and **Proxy User Password**.
 - d. On the **Options** tab, select **Sent Heartbeat Data** and/or **Send Fault Events** to send this data as part of the phone home information.
 - e. Click **Apply** to continue.
- n. In the **Confirmation** screen, review the configuration information you have added.

Note – Be sure the configuration information is accurate before continuing.

- o. Click **Finish** on the wizard **Confirmation** screen.

The system configures the settings and indicates that in the **Save Configuration** screen. It also displays a message that both servers must reboot for the failover changes to be applied.

- p. Click **Close** on the **Save Configuration** screen.

▼ To Activate the Sun StorageTek NAS Gateway License

1. In the navigation panel, select **System Operations > Activate Options**.
2. Click the **Temporary Licenses** button.

3. Select Sun StorageTek NAS Gateway, and click Apply.

The State displays “valid” and the Status displays “active.”

4. Log out of Web Admin, and close all browser instances.

Note – You must close *all* browser windows you have open. If you don’t, the license feature will not set up properly.

5. Restart the Web Admin using [Step 1](#) through [Step 3](#) in “To Set Up Basic Configuration” on page 160.

6. When you have logged in to Web Admin, on the main System Status window, check the Features Enabled to be sure that “Sun StorageTek NAS Gateway” appears.

7. In the navigation panel, select RAID > View HBA Information to view the port World Wide Names (WWNs) of the HBA ports.

Each HBA port is delineated by a tab at the top of the window. HBA port numbering refers to the physical HBA ports from right to left and bottom to top, as shown in [TABLE 5-3](#).

TABLE 5-3 HBA Port Numbering

HBA Port Number	HBA Port Physical Location	HBA Port Name
1	Port 1 PCI1	isp1
2	Port 2 PCI1	isp2
3	Port 1 PCI0	isp3
4	Port 2 PCI0	isp4

Note – If a third HBA card is installed to allow tape backup, then the data ports will be 1, 2, 5, and 6.

For each HBA port, the port WWN is listed in the upper portion of the window. The port WWNs are used to map the LUNs on the SAN storage device or to zone these ports on the fabric switch.

8. Write down the port WWNs of all the HBA ports.

WWNs consist of 16 characters that start after the “x” and do not include the “.”

9. Log out of Web Admin and close the browser.

10. Configure SAN storage using the appropriate instructions:

- [“Sun StorageTek 6130 Array” on page 173](#)

- [“To Configure Storage on the Sun StorEdge 6920 System” on page 178](#)
- [“To Configure Storage on the Sun StorEdge 99xx System” on page 179](#)

11. Configure storage on the Sun StorageTek 5320 NAS Gateway System using the instructions in the next section.

▼ To Configure Storage on the Sun StorageTek 5320 NAS Gateway System Single Server

1. Reboot the Sun StorageTek 5320 NAS Gateway System server so that it can detect the storage.

You can reboot using Web Admin or the LCD panel.

To use Web Admin to reboot:

- a. **In the navigation panel, select System Operations > Shut Down the Server.**
- b. **Select Reboot This Head, and click Apply.**

To use the LCD panel to reboot:

- a. **On the server’s LCD panel, select B. Shutdown Server from the menu.**
- b. **Select B. Reboot. The LCD displays “Are you sure? No.” Press the up arrow button to change to “Yes.” Then press the ENTER or the right arrow button to reboot.**

2. After the server has rebooted, use Web Admin to configure file volumes.

3. From the navigation panel, choose File Volume Operations > Create File Volumes to create a volume.

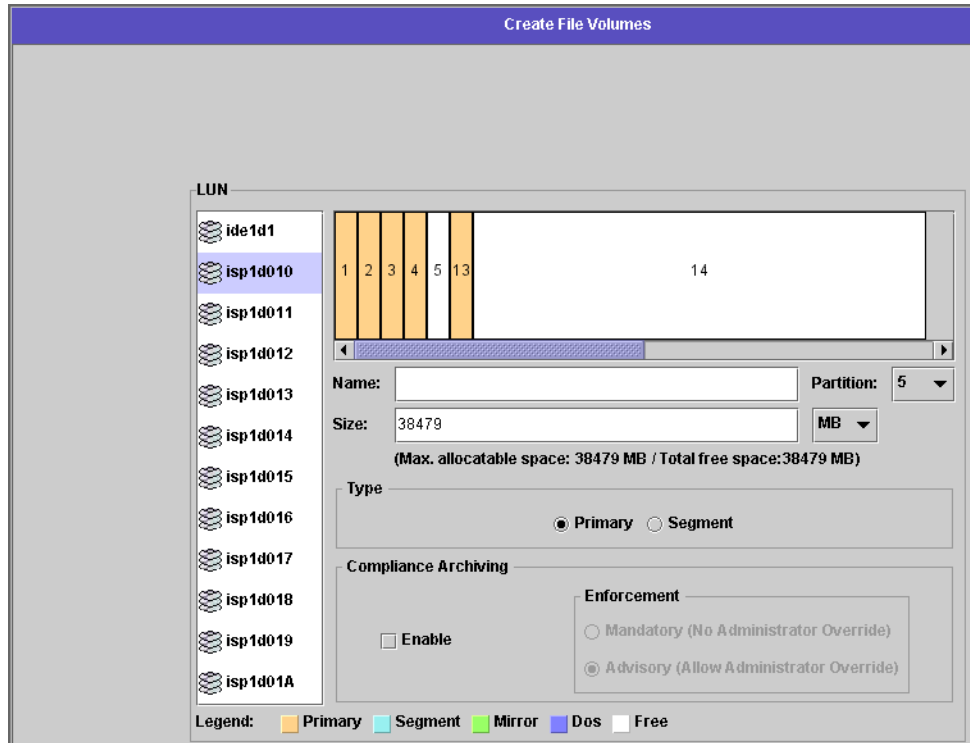

4. Select the logical unit number (LUN) on which you want to create the volume. Enter a name and size for the volume. Select a partition (if available) on which you want to create the volume and select the volume type.
For more information about the fields, legends, and buttons on this panel, click the Help button.
5. Click Apply to create the new volume.

Initial Cluster Gateway System Configuration

Note – These instructions apply to the Sun StorageTek 5320 NAS Cluster Gateway System configuration only. For Sun StorageTek 5320 NAS Gateway System configuration instructions, refer to [“Initial Gateway System Single-Server Configuration” on page 159](#). For Sun StorageTek 5320 NAS Cluster Appliance configuration instructions, refer to [Chapter 4](#).

To complete the initial Sun StorageTek 5320 NAS Cluster Gateway System configuration, you must specify the following:

- IP addresses
- Basic system configuration
- Storage and LUN configuration
- Failover configuration
- LUN paths

▼ To Set IP Addresses

If your network supports DHCP, an IP address is automatically assigned to your LAN ports.

Note – You can bypass DHCP discovery if you have a fixed IP address. However, there is a possibility that aborting the DHCP process will cause the server to reboot. To bypass DHCP discovery, during the boot sequence when the LCD panel displays “DHCP Discovery NIC X,” you can press any key on the LCD panel and confirm the “Abort DHCP?” message by pressing the right arrow button on the panel. Then you can manually set the static IP address using the following instructions.

If DHCP is not available or you want to assign a static IP address, use server H1’s LCD panel:

1. **Select Menu.**
2. **Select A. Network Config.**

3. Select A. Set Gateway and enter the gateway address.

To enter data, use the up and down arrows to select digits, dots, or spaces. Then use the ENTER or right arrow button to accept each character.

4. Select C. Set Port-emc2 (or emc3 or emc4) and enter the IP address, subnet mask, and broadcast address as prompted.

This IP address information is assigned to the first regular (non-heartbeat) LAN port on your system.

5. Select Escape twice to return to the main menu.



Caution – Do not change the private IP address on the network port that is used for the HB port (heartbeat port), emc1.

Note – If you would like to verify your settings on the LCD panel, HB Port shows a private IP address, and Port emc2 or Port emc3 or Port emc4 shows the information you just entered.

You can edit the port information and assign addresses to other ports in the same way.

Basic Dual-Server System Configuration

To configure the system, you must set up basic system configuration and activate the license for server H1, and then repeat the steps for server H2.

Note – You must perform all basic system configuration tasks on both servers before proceeding to [“To Configure LUN Paths” on page 173](#).

▼ To Set Up Basic Configuration

- 1. From a client on the same network, open a Java platform-enabled web browser with Java Plug-in and type the IP address for server H1.**
- 2. Accept the “Applet Security Certificate” and wait until the Web Admin applet is loaded on this system.**
- 3. On the Web Admin login screen, click Apply.**

The password can be set later. Refer to the *Sun StorageTek 5320 NAS OS Administration Guide*.

4. On the Set Time and Date panel, select the date, the time, and the time zone, and click Apply. Then click Yes to confirm.

This sets the secure clock to the same time and date. Make sure you set the time and date accurately as you can set the secure clock only once.

5. Read the license agreement in the Configuration wizard dialog box, and click Accept to proceed with the following wizard steps:
 - a. Click Next in the Welcome dialog box.
 - b. From the Select Environment screen, configure Microsoft Windows, UNIX, or both environments. Click Next to continue.

You can add additional configuration information later.
 - c. From the Set Server Name screen, type the server name and populate the other fields accordingly, and then click Next.
 - d. On the Enable Failover screen, skip the screen by clicking Next.



Caution – Do not enable failover at this time. Storage must be configured before failover can be enabled.

In the partner configuration part of the screen, the system initially sets default server names head1 and head2. You can change these defaults later when you configure failover (see [“To Configure Failover”](#) on page 171).

- e. On the Configure Network Adapters screen, verify that the information is correct, and click Next to continue.

You can configure additional network interfaces at this time. However, if you change the configuration of the port to which the browser is attached, the browser session is disconnected.
- f. On the Set Gateway Address screen, verify that the address is correct, and, if not, enter the gateway address. Click Next to continue.
- g. For all the other wizard configuration steps, refer to the *Sun StorageTek 5320 NAS OS Administration Guide* for more information.

Note – When adding your DNS server, click Add to ensure the DNS server has been added.

- h. In the Confirmation screen, review the configuration information you have added.

Note – Be sure the configuration information is accurate before continuing.

- i. **Click Finish on the wizard Confirmation screen.**

The system configures the settings and indicates that in the Save Configuration screen.

- j. **Click Close on the Save Configuration screen.**

▼ To Activate the Sun StorageTek NAS Gateway License

1. **In the navigation panel, select System Operations > Activate Options.**

2. **Click the Temporary Licenses button.**

3. **Select Sun StorageTek NAS Gateway, and click Apply.**

The State displays “valid” and the Status displays “active.”

4. **Log out of Web Admin, and close all browser instances.**

Note – You must close *all* browser windows you have open. If you don’t, the license feature will not set up properly.

5. **Restart Web Admin using Step 1 through Step 3 in “Basic Dual-Server System Configuration” on page 167.**

6. **When you have logged in to Web Admin, on the main System Status window, check the Features Enabled to be sure that “Sun StorageTek NAS Gateway” appears.**

7. **In the navigation panel, select RAID > View HBA Information to view the port World Wide Names (WWNs) of the HBA ports.**

The port WWNs are used to map the LUNs on the SAN storage device or to zone these ports on the fabric switch.

Each HBA port is delineated by a tab at the top of the window. HBA port numbering refers to the physical HBA ports from right to left and bottom to top. Refer to [TABLE 5-3, “HBA Port Numbering” on page 163](#).

For each HBA port, the port WWN is listed in the upper portion of the window. The port WWNs are used to map the LUNs on the SAN storage device or to zone these ports on the fabric switch.

8. **Write down the port WWNs of all the HBA ports.**

WWNs consist of 16 characters that start after the “x” and do not include the “.”

9. **Log out of Web Admin and close the browser.**

▼ To Set Up Server H2

1. **Assign server H2's IP address and gateway address using the instructions in "To Set IP Addresses" on page 166.**
2. **Set up server H2's basic configuration using the instructions in "To Set Up Basic Configuration" on page 167.**
3. **Activate server H2's license using the instructions "To Activate the Sun StorageTek NAS Gateway License" on page 169.**

▼ To Configure SAN Storage on the Cluster Gateway System

1. **Configure SAN storage using the appropriate instructions:**
 - "Sun StorageTek 6130 Array" on page 173
 - "Sun StorageTek 6140 Array" on page 178
 - "To Configure Storage on the Sun StorEdge 6920 System" on page 178
 - "To Configure Storage on the Sun StorEdge 99xx System" on page 179
2. **Configure storage on the Sun StorageTek 5320 NAS Cluster Gateway System, using the instructions in the next section.**

▼ To Configure Storage on the Cluster Gateway System

1. **Power off server H1 and H2 using Web Admin or the LCD panel:**
 - Using Web Admin, in the navigation panel, select System Operations > Shut Down the Server. Then select Halt Both Heads, and click Apply.
 - Using the LCD panel, select B. Shutdown Server from the menu. Then select A. Power Off. The LCD displays "Are you sure? No." Press the up arrow button to change to "Yes." Then press the ENTER or right arrow button to shut down.
2. **Power on server H1.**
3. **When server H1 has restarted and the LCD panel displays QUIET, press the ENTER or right arrow button. Then press the down arrow button until the flashing cursor is on C. Take All LUNs.**
4. **Press the ENTER or right arrow button to select C. Take All LUNs.**

5. When prompted to “Take All LUNs? No,” press the up arrow button to select “Yes,” and press the ENTER or right arrow button to start taking LUNs.

The LCD displays “Taking LUNs” followed by a message “Took *n* LUNs.” After a few seconds, the display returns to the Network Config menu.

Note – If server H2 is still powered on when you select C. Take All LUNs, you are prompted to shut down the partner (server H2). After you power off server H2, the display on server H1 changes to “Taking All LUNs.”

6. Select Escape to return to the main menu.

Server H1 is now in the ALONE state.

▼ To Configure Failover

1. Launch a new browser window and enter server H1's IP address.
2. If necessary, accept the “Applet Security Certificate” and wait until the Web Admin applet is loaded.
3. On the Web Admin login screen, click Apply.

4. In the navigation panel, select High Availability > Recover.

5. In the Current RAID Configuration and Restore RAID Configuration panels, confirm that all the LUNs are listed in the Head 1 columns.

There is nothing listed under any Head 2 column.

6. In the navigation panel, select High Availability > Enable Failover.

7. Select Automatic Failover and Enable Link Failover.

A default value of 60 seconds is assigned in both the Down Timeout and Restore Timeout fields.

8. Type the Partner Configuration Name and the Gateway IP address for server H2 (Partner Name factory default is “head2”), using the Tab key to move between fields.

The information you enter here is used to start server H2 through the heartbeat connection. The Partner Name is the host name that you assigned to server H2. Any network information server H2 obtained through DHCP or manually through the LCD panel is displayed here and can be corrected, if necessary.

The field for Private IP for the heartbeat connection should already be populated (IP 10.10.10.2 private network) and should not be changed.

9. Click Apply.

10. A message appears stating that the system will be rebooted for changes to take effect. Confirm that you want to reboot both servers.

Server H1 reboots automatically, and you need to manually restart server H2.

11. If server H2 is powered off, power it on. Otherwise, reboot server H2 in one of these ways:
 - Using Web Admin for server H2, select System Operations > Shut Down the Server.
 - Use the LCD panel on server H2.
12. When the servers have restarted, log in to the Web Admin on server H1.
13. In the main Server Status window, check that the Head Status is ALONE and the Partner Status is QUIET.

▼ To Assign LUNs to Server H2

1. Using Web Admin on server H1, in the navigation panel, select High Availability > Recover.
2. In the Restore RAID Configuration window, assign some of the LUNs to server H2.

Note – You must assign at least one LUN to each server. In most situations, you will want approximately equal amounts of storage assigned to each server in the cluster.

3. Click Apply.

Note – Verify that the Current RAID Configuration window shows the LUN assignments.

4. Click Recover, and the LUNs are distributed between both the servers.

At this point, both servers change to the NORMAL state.

Note – Verify that both servers are in the NORMAL state on the LCD display or on the Web Admin main Server Status window, where the Head and Partner Status should display NORMAL.

5. Follow these steps first on server H1 and then on server H2:

- a. Using Web Admin on server H1, in the navigation panel, select Network Configuration > Configure TCP/IP > Configure Network Adapters.

- b. Check that the emc or emf NIC port being used displays the partner IP alias address.

▼ To Configure LUN Paths

You need to assign LUN paths on each server to balance multipath access from each server to storage.

Follow these steps first on server H1 and then on server H2:

1. In the Web Admin navigation panel, select **High Availability > Set LUN Path**.
2. Select a LUN and click **Edit**.
3. Select the desired storage from the **Primary Path drop-down menu**.

Evenly divide the assignment of LUNs to the two available paths. For example, the first and third LUN to 1/0 and the second and fourth LUN to 1/1.

4. Click **Apply**.

For additional information about LUNs and other detailed software setup and use, click **Help** or refer to the *Sun StorageTek NAS OS Administration Guide*.

SAN Storage Configuration

To configure storage for the Sun StorageTek 5320 NAS Gateway System, you must first configure the SAN storage system and then finish configuration on the Sun StorageTek 5320 NAS Gateway System.

Note – You must perform all the storage and LUN configuration tasks to complete the initial configuration.

If you are using fabric switches, use the switch user interface (UI) to include all WWNs of the SAN storage and of the HBAs on the Sun StorageTek 5320 NAS Gateway System.

Sun StorageTek 6130 Array

To use the Sun StorageTek 6130 array for Sun StorageTek 5320 NAS Gateway System storage, there are certain requirements.

Note – Special configuration requirements do not apply to the Sun StorageTek 6140 array. Refer to [“Sun StorageTek 6140 Array” on page 178](#) for basic Sun StorageTek 6140 array configuration.

The Sun StorageTek 6130 array requires the software and firmware shown in [TABLE 5-4](#) to interoperate with the Gateway System.

TABLE 5-4 Required Sun StorageTek 6130 Array Software and Firmware

Software	Version (minimum)	Patch ID
Sun StorageTek 6130 array management software	1.3	118164-06
Controller CRM-F firmware	06.12.09.10	117856-18
Array firmware installer		118185-14

If the Sun StorageTek 6130 array is currently at version 1.2, upgrade the management software to version 1.3 before installing the patches.

If the Sun StorageTek 6130 array is currently at version 1.3, install the patches as described in [“To Upgrade the Sun StorageTek 6130 Array Firmware” on page 175](#).

▼ To Upgrade the Sun StorageTek 6130 Array Management Software

1. From the Sun StorageTek 6130 array management interface, log in to the Sun Storage Automated Diagnostic Environment and clear all existing alarms.
2. Log in to the management host as `root`.
3. Download the latest Sun StorageTek 6130 host software package v1.3 for Solaris OS from <http://sunsolve.sun.com> to any working directory on the management host.
4. Unzip the distribution file and untar the file.
5. Enter the following command:

```
./upgrade -n
```

The `-n` option specifies a non-interactive upgrade. After asking whether you want to upgrade software or firmware, the script completes the upgrade without pausing for questions.

When the installation is complete, a confirmation is displayed followed by the date and time that the upgrade finished.

You can now install the patches as described in the next section.

▼ To Upgrade the Sun StorageTek 6130 Array Firmware

1. **Download the required patches (see TABLE 5-4) from**
`http://sunsolve.sun.com/`.
2. **Stop all I/O to the disk drives.**
3. **Log in to the management host as `root`.**
4. **Change to the directory to which you downloaded the software.**
5. **Install each patch by following the instructions in the patch README file.**
6. **Verify that the latest patches are installed:**
 - a. **Open a supported browser.**
 - b. **Enter the IP address of the management host using this format:**
`https://host_IP:6789`
 - c. **Log in to the management software.**
 - d. **Click Sun StorageTek 6130 Configuration Service.**
The Array Summary page is displayed.
 - e. **Verify that the Firmware Version column displays 06.12.09.10 (or greater).**

Verifying the Array

To verify that the array is seen by the Sun StorageTek 6130 host software, use automatic discovery or manual registration.

▼ To Automatically Verify the Array

If the array is on the same subnet as the management host, you can automatically verify the array.

1. **Open a supported browser.**
2. **Type the IP address of the management host using this format:**

`https://host-IP:6789`

3. **Log in to the management software.**

4. Click Sun StorageTek 6130 Configuration Service.

The Array Summary page is displayed.

5. On the Array Summary page, click Auto Discover to display arrays that are on the same subnet as the management host.

Note – It takes approximately 2 minutes for the software to discover each array.

6. Verify that the array is listed on the Array Summary page.

▼ To Manually Register the Array

If the array is not on the same subnet as the management host, you must manually register the array.

1. Open a supported browser.

2. Type the IP address of the management host using this format:

```
https://host-IP:6789
```

3. Log in to the management software.

4. Click Sun StorageTek 6130 Configuration Service.

The Array Summary page is displayed.

5. On the Array Summary page, click Register Array.

The Array Registration page is displayed.

6. Enter the IP address of the controller and click OK.

7. Verify that the array is listed on the Array Summary page.

Making the Sun StorageTek 6130 Array SAN Storage Available

To make the Sun StorageTek 6130 SAN storage available to the NAS Gateway system, do the following:

1. Create an initiator on the Sun StorageTek 6130 array.
2. Define a new volume on the Sun StorageTek 6130 array.
3. Create a NAS volume on the NAS server.

▼ To Create an Initiator

1. Log in to the Sun StorageTek 6130 Configuration Service software, and click **Physical Storage. Initiators**. The **Initiator Summary** page is displayed.
2. Click **New**. The **New Initiator Summary** page is displayed.
3. Enter a name for the new initiator, using a maximum of 30 characters.
4. Select an existing World Wide Name (WWN), or enter a new one.
5. Select the host for the new initiator.
6. Select SE_5xxx as the host type.
7. Click **OK**. The **Initiator Summary** page displays the initiator name, host name, host type, and WWN of the new initiator.

▼ To Define a Sun StorageTek 6130 Volume

1. In the Sun StorageTek 6130 Configuration Service interface, click **Logical Storage > Volumes**. The **Volume Summary** page is displayed.
2. Click **New**. The **New Volume** wizard is displayed.
3. Enter a name and capacity for the volume.
4. Select the virtual disk you want to use for this volume.
5. Map the volume to the Sun StorageTek 5320 NAS Gateway host. The new volume is displayed on the **Volume Summary** page.

▼ To Define a NAS 5320 Volume

1. From a client of the NAS server, log in to the **Web Administrator**.
2. Create a NAS volume on the Sun StorageTek 6130 volume and format it:
 - a. Open the **File Volume Operations** menu.
 - b. Select **Create File Volumes**.
 - c. Click **Scan New Disks**.

The newly created 6130 LUN is displayed on the left side of the center pane.

- d. **Name the volume, enter the required parameters, and click Apply.**

See the Sun StorageTek 5320 NAS OS Administration Guide for information about the required parameters.

3. Complete configuration on the Sun StorageTek 5320 NAS Gateway System.

For the single-server system, refer to [“To Configure Storage on the Sun StorageTek 5320 NAS Gateway System Single Server”](#) on page 164.

For the dual-server HA system, refer to [“Configure SAN storage using the appropriate instructions:”](#) on page 170.

Sun StorageTek 6140 Array

Configuring storage on the Sun StorageTek 6140 array requires several steps.

▼ To Configure Storage on the Sun StorageTek 6140 Array

1. **Using the Sun StorageTek 6140 Configuration Service, create a new initiator.** Use the same process as for the 6130 array, detailed in [“To Create an Initiator”](#) on page 177.

2. **Create a new volume and map it to the Sun StorageTek 5320 NAS Gateway System. Use the same process as for the 6130 array, detailed in [“To Define a Sun StorageTek 6130 Volume”](#) on page 177 and [“To Define a NAS 5320 Volume”](#) on page 177.**

3. **Complete configuration on the Sun StorageTek 5320 NAS Gateway System.**

For the single-server system, refer to [“To Configure Storage on the Sun StorageTek 5320 NAS Gateway System Single Server”](#) on page 164.

For the dual-server HA system, refer to [“Configure SAN storage using the appropriate instructions:”](#) on page 170.

▼ To Configure Storage on the Sun StorEdge 6920 System

1. **Using the Sun StorEdge 6920 Configuration Service, select the NAS storage profile `nfs_stripe` for RAID 5 or `nfs_mirror` for RAID 1/0.**

2. **Create a storage pool to be used by the Sun StorageTek 5320 NAS Gateway System.**

3. **Create volumes in the storage pool.**

4. **Map the initiators associated with the Sun StorageTek 5320 NAS Gateway System HBA WWNs to the Sun StorEdge 6920 storage volumes.**

5. Complete configuration on the Sun StorageTek 5320 NAS Gateway System.

For the single server system, refer to [“To Configure Storage on the Sun StorageTek 5320 NAS Gateway System Single Server”](#) on page 164.

For the dual-server HA system, refer to [“Configure SAN storage using the appropriate instructions:”](#) on page 170.

▼ To Configure Storage on the Sun StorEdge 99xx System

1. Using the Sun StorEdge 99xx system user interface (UI), set fabric to ON.

2. If you are directly attaching to storage (not using a fabric switch), choose FC-AI connection.

3. If you are using a fabric switch, choose point-to-point connection.

4. Select a 00 host group node type.

5. Enable LUN Manager.

6. Build Array Groups.

7. Complete configuration on the Sun StorageTek 5320 NAS Gateway System.

For the single-server system, refer to [“To Configure Storage on the Sun StorageTek 5320 NAS Gateway System Single Server”](#) on page 164.

For the dual-server HA system, refer to [“To Set Up Server H2”](#) on page 170.

Hardware Technical Specifications

This appendix contains information about the environmental and physical characteristics as well as the power requirements of the Sun StorageTek 5320 NAS Appliance, the Sun StorEdge 5300 RAID Controller Enclosure (CU), and the Sun StorEdge 5300 Expansion Enclosure (EU).

FIGURE A-1 Power Requirements

Specification	Unit (if variable)	Value
Voltage		90-264VAC
Frequency		47-63 Hz
AC current input (typical)	Appliance	4.0A (115V~), or 2.0A (230V~)
	CU and EU	6.8A (115V~), or 2.9A (230V~) (16x300GB FC drives)
Power consumption	Appliance	460VA (from AC source), maximum 276W (from power supply), maximum
	Power availability	550W maximum (from power supply)
	CU	435VA, 261W (typical unit- 8x500GB SATA drives) 580VA, 348W (typical unit- 16x500GB SATA drives) 478VA, 287 W (typical unit- 8x300GB FC drives) 667VA, 400W (typical unit- 16x300GB FC drives)
	EU	405VA, 243W (typical unit- 8x500GB SATA drives) 550VA, 330W (typical unit- 16x500GB SATA drives) 448VA, 269W (typical unit- 8x300GB FC drives) 637VA, 382W (typical unit- 16x300GB FC drives) Hard drive (500GB SATA) 13.6W Hard drive (300GB FC) 18.0W
	Power availability	600W maximum (from power supply)

FIGURE A-1 Power Requirements (*Continued*)

Power cord		SJT or SVT 18 SWG min, 3 conductor, with 250V, 10A plug and socket
Head dissipation	Appliance	942 BTU/hr (typical)
	CU and EU	1365 BTU/hr (typical- 16x300GB FC drives)
	Hard drive (500 GB SATA)	48 BTU/hr (typical)
	Hard drive (300GB FC)	37 BTU/hr (typical)

TABLE A-1 Physical Characteristics

Unit	Specification	Value
Appliance	Dimension (HxWxD)	8.76 cm x 44.5 cm x 64.0 cm (3.45 in x 17.52 in x 25.2 in)
	Weight	23.7 kg (52.1 lb)
	Rack height	2U
CU and EU	Dimension (HxWxD)	13.2 cm x 48.2 cm x 56.4 cm (5.2 in x 19 in x 22.2 in)
	Weight	44.5 kg (98 lb)
	Rack height	3U

TABLE A-2 Environmental Specifications

Specification	Unit	Appliance	CU and EU
Temperature	Operating	+10°C to +35°C (+50°F to +95°F)	+10°C to +35°C (+50°F to +95°F)
	Non-operating/ storage	-40°C to +65°C (-40°F to +149°F)	-10°C to +45°C (+14°F to +113°F)
Humidity	Operating	10% to 90%, non-condensing	20% to 80%, non-condensing
	Non-operating/ storage	10% to 93%, non-condensing	10% to 90%, non-condensing

Third-Party License Agreements

1 The software provided as part of the Sun StorEdge 5210, 5310, 5310C NAS Appliance or Sun StorEdge 5310 NAS Gateway system may contain code provided by the following organizations or individuals under the described licenses.

2 The University of California Berkley Software Distribution License
Copyright (c) 1991 The Regents of the University of California.
All rights reserved.

Redistribution and use in source and binary forms, with or without modification, are permitted provided that the following conditions are met: 1.Redistributions of source code must retain the above copyright notice, this list of conditions and the following disclaimer. 2.Redistributions in binary form must reproduce the above copyright notice, this list of conditions and the following disclaimer in the documentation and/or other materials provided with the distribution. 3.All advertising materials mentioning features or use of this software must display the following acknowledgement: This product includes software developed by the University of California, Berkeley and its contributors. 4.Neither the name of the University nor the names of its contributors may be used to endorse or promote products derived from this software without specific prior written permission. THIS SOFTWARE IS PROVIDED BY THE REGENTS AND CONTRIBUTORS "AS IS" AND ANY EXPRESS OR IMPLIED WARRANTIES, INCLUDING, BUT NOT LIMITED TO, THE IMPLIED WARRANTIES OF MERCHANTABILITY AND FITNESS FOR A PARTICULAR PURPOSE ARE DISCLAIMED. IN NO EVENT SHALL THE REGENTS OR CONTRIBUTORS BE LIABLE FOR ANY DIRECT, INDIRECT, INCIDENTAL, SPECIAL, EXEMPLARY, OR CONSEQUENTIAL DAMAGES (INCLUDING, BUT NOT LIMITED TO, PROCUREMENT OF SUBSTITUTE GOODS OR SERVICES; LOSS OF USE, DATA, OR PROFITS; OR BUSINESS INTERRUPTION) HOWEVER CAUSED AND ON ANY THEORY OF LIABILITY, WHETHER IN CONTRACT, STRICT LIABILITY, OR TORT (INCLUDING NEGLIGENCE OR OTHERWISE) ARISING IN ANY WAY OUT OF THE USE OF THIS SOFTWARE, EVEN IF ADVISED OF THE POSSIBILITY OF SUCH DAMAGE.

3 NetBSD License

Copyright (c) 1998 The NetBSD Foundation, Inc.

All rights reserved.

This code is derived from software contributed to The NetBSD Foundation by Lennart Augustsson (lennart@augustsson.net) at Carlstedt Research & Technology.

Redistribution and use in source and binary forms, with or without modification, are permitted provided that the following conditions are met: 1.Redistributions of source code must retain the above copyright notice, this list of conditions and the following disclaimer. 2.Redistributions in binary form must reproduce the above copyright notice, this list of conditions and the following disclaimer in the documentation and/or other materials provided with the distribution. 3.All advertising materials mentioning features or use of this software must display the following acknowledgement: This product includes software developed by the NetBSD Foundation, Inc. and its contributors. 4.Neither the name of The NetBSD Foundation nor the names of its contributors may be used to endorse or promote products derived from this software without specific prior written permission. THIS SOFTWARE IS PROVIDED BY THE NETBSD FOUNDATION, INC. AND CONTRIBUTORS "AS IS" AND ANY EXPRESS OR IMPLIED WARRANTIES, INCLUDING, BUT NOT LIMITED TO, THE IMPLIED WARRANTIES OF MERCHANTABILITY AND FITNESS FOR A PARTICULAR PURPOSE ARE DISCLAIMED. IN NO EVENT SHALL THE FOUNDATION OR CONTRIBUTORS BE LIABLE FOR ANY DIRECT, INDIRECT, INCIDENTAL, SPECIAL, EXEMPLARY, OR CONSEQUENTIAL DAMAGES (INCLUDING, BUT NOT LIMITED TO, PROCUREMENT OF SUBSTITUTE GOODS OR SERVICES; LOSS OF USE, DATA, OR PROFITS; OR BUSINESS INTERRUPTION) HOWEVER CAUSED AND ON ANY THEORY OF LIABILITY, WHETHER IN CONTRACT, STRICT LIABILITY, OR TORT (INCLUDING NEGLIGENCE OR OTHERWISE) ARISING IN ANY WAY OUT OF THE USE OF THIS SOFTWARE, EVEN IF ADVISED OF THE POSSIBILITY OF SUCH DAMAGE.

4 The Massachusetts Institute of Technology License

Copyright 1990 by the Massachusetts Institute of Technology.

All Rights Reserved.

Export of this software from the United States of America may require a specific license from the United States Government. It is the responsibility of any person or organization contemplating export to obtain such a license before exporting. WITHIN THAT CONSTRAINT, permission to use, copy, modify, and distribute this software and its documentation for any purpose and without fee is hereby granted, provided that the above copyright notice appear in all copies and that both that copyright notice and this permission notice appear in supporting documentation, and that the name of M.I.T. not be used in advertising or publicity pertaining to distribution of the software without specific, written prior permission. Furthermore if you modify this software you must label your software as modified software and not distribute it in such a fashion that it might be confused with the original M.I.T. software. M.I.T. makes no representations about the suitability of this software for any purpose. It is provided "as is" without express or implied warranty.

5 The OpenVision Technologies Inc License
Copyright 1993 by OpenVision Technologies, Inc.

Permission to use, copy, modify, distribute, and sell this software and its documentation for any purpose is hereby granted without fee, provided that the above copyright notice appears in all copies and that both that copyright notice and this permission notice appear in supporting documentation, and that the name of OpenVision not be used in advertising or publicity pertaining to distribution of the software without specific, written prior permission. OpenVision makes no representations about the suitability of this software for any purpose. It is provided "as is" without express or implied warranty.

OPENVISION DISCLAIMS ALL WARRANTIES WITH REGARD TO THIS SOFTWARE, INCLUDING ALL IMPLIED WARRANTIES OF MERCHANTABILITY AND FITNESS, IN NO EVENT SHALL OPENVISION BE LIABLE FOR ANY SPECIAL, INDIRECT OR CONSEQUENTIAL DAMAGES OR ANY DAMAGES WHATSOEVER RESULTING FROM LOSS OF USE, DATA OR PROFITS, WHETHER IN AN ACTION OF CONTRACT, NEGLIGENCE OR OTHER TORTIOUS ACTION, ARISING OUT OF OR IN CONNECTION WITH THE USE OR PERFORMANCE OF THIS SOFTWARE.

6 The University of Michigan License
Copyright (c) 1990 Regents of the University of Michigan.
All rights reserved.

Redistribution and use in source and binary forms are permitted provided that this notice is preserved and that due credit is given to the University of Michigan at Ann Arbor. The name of the University may not be used to endorse or promote products derived from this software without specific prior written permission. This software is provided "as is" without express or implied warranty.

7 The Internet Software Consortium License
Copyright (c) 1997 The Internet Software Consortium.
All rights reserved.

Redistribution and use in source and binary forms, with or without modification, are permitted provided that the following conditions are met: 1.Redistributions of source code must retain the above copyright notice, this list of conditions and the following disclaimer. 2.Redistributions in binary form must reproduce the above copyright notice, this list of conditions and the following disclaimer in the documentation and/or other materials provided with the distribution. 3.Neither the name of The Internet Software Consortium nor the names of its contributors may be used to endorse or promote products derived from this software without specific prior written permission. THIS SOFTWARE IS PROVIDED BY THE INTERNET SOFTWARE CONSORTIUM AND CONTRIBUTORS "AS IS" AND ANY EXPRESS OR IMPLIED WARRANTIES, INCLUDING, BUT NOT LIMITED TO, THE IMPLIED WARRANTIES OF MERCHANTABILITY AND FITNESS FOR A PARTICULAR PURPOSE ARE DISCLAIMED. IN NO EVENT SHALL THE INTERNET SOFTWARE

CONSORTIUM OR CONTRIBUTORS BE LIABLE FOR ANY DIRECT, INDIRECT, INCIDENTAL, SPECIAL, EXEMPLARY, OR CONSEQUENTIAL DAMAGES (INCLUDING, BUT NOT LIMITED TO, PROCUREMENT OF SUBSTITUTE GOODS OR SERVICES; LOSS OF USE, DATA, OR PROFITS; OR BUSINESS INTERRUPTION) HOWEVER CAUSED AND ON ANY THEORY OF LIABILITY, WHETHER IN CONTRACT, STRICT LIABILITY, OR TORT (INCLUDING NEGLIGENCE OR OTHERWISE) ARISING IN ANY WAY OUT OF THE USE OF THIS SOFTWARE, EVEN IF ADVISED OF THE POSSIBILITY OF SUCH DAMAGE.

8 Carnegie Mellon University License

The Carnegie Mellon University license appears in an SNMP header file.

Copyright 1988, 1989 by Carnegie Mellon University

All Rights Reserved

Permission to use, copy, modify, and distribute this software and its documentation for any purpose and without fee is hereby granted, provided that the above copyright notice appear in all copies and that both that copyright notice and this permission notice appear in supporting documentation, and that the name of CMU not be used in advertising or publicity pertaining to distribution of the software without specific, written prior permission. CMU DISCLAIMS ALL WARRANTIES WITH REGARD TO THIS SOFTWARE, INCLUDING ALL IMPLIED WARRANTIES OF MERCHANTABILITY AND FITNESS, IN NO EVENT SHALL CMU BE LIABLE FOR ANY SPECIAL, INDIRECT OR CONSEQUENTIAL DAMAGES OR ANY DAMAGES WHATSOEVER RESULTING FROM LOSS OF USE, DATA OR PROFITS, WHETHER IN AN ACTION OF CONTRACT, NEGLIGENCE OR OTHER TORTIOUS ACTION, ARISING OUT OF OR IN CONNECTION WITH THE USE OR PERFORMANCE OF THIS SOFTWARE.

9 Troll FTP License

Copyright 1995-2000 Trolltech AS. Copyright 2001 Arnt Gulbrandsen.

Use, modification and distribution is allowed without limitation, warranty, or liability of any kind.

10 RSA Data Security, Inc. Message Digest License

Copyright (C) 1991-2, RSA Data Security, Inc. Created 1991.

All rights reserved.

License to copy and use this software is granted provided that it is identified as the "RSA Data Security, Inc. MD4 Message-Digest Algorithm" in all material mentioning or referencing this software or this function. License is also granted to make and use derivative works provided that such works are identified as "derived from the RSA Data Security, Inc. MD4 Message-Digest Algorithm" in all material mentioning or referencing the derived work. RSA Data Security, Inc. makes no representations concerning either the merchantability of this software or the suitability of this software for any particular purpose. It is provided "as is" without express or implied warranty of any kind. These notices must be retained in any copies of any part of this documentation and/or software.

11 MD5 License "THE BEER-WARE LICENSE" (Revision 42):

<phk@login.dknet.dk> wrote this file. As long as you retain this notice you can do whatever you want with this stuff. If we meet some day, and you think this stuff is worth it, you can buy me a beer in return. Poul-Henning Kamp

12 NIS License

Copyright (c) 1996, 1997 Bill Paul <wpaul@ctr.columbia.edu>.
All rights reserved.

Redistribution and use in source and binary forms, with or without modification, are permitted provided that the following conditions are met: 1.Redistributions of source code must retain the above copyright notice, this list of conditions and the following disclaimer. 2.Redistributions in binary form must reproduce the above copyright notice, this list of conditions and the following disclaimer in the documentation and/or other materials provided with the distribution. 3.All advertising materials mentioning features or use of this software must display the following acknowledgement: This product includes software developed by Bill Paul. 4.Neither the name of the author nor the names of any co-contributors may be used to endorse or promote products derived from this software without specific prior written permission. THIS SOFTWARE IS PROVIDED BY Bill Paul AND CONTRIBUTORS "AS IS" AND ANY EXPRESS OR IMPLIED WARRANTIES, INCLUDING, BUT NOT LIMITED TO, THE IMPLIED WARRANTIES OF MERCHANTABILITY AND FITNESS FOR A PARTICULAR PURPOSE ARE DISCLAIMED. IN NO EVENT SHALL Bill Paul OR CONTRIBUTORS BE LIABLE FOR ANY DIRECT, INDIRECT, INCIDENTAL, SPECIAL, EXEMPLARY, OR CONSEQUENTIAL DAMAGES (INCLUDING, BUT NOT LIMITED TO, PROCUREMENT OF SUBSTITUTE GOODS OR SERVICES; LOSS OF USE, DATA, OR PROFITS; OR BUSINESS INTERRUPTION) HOWEVER CAUSED AND ON ANY THEORY OF LIABILITY, WHETHER IN CONTRACT, STRICT LIABILITY, OR TORT (INCLUDING NEGLIGENCE OR OTHERWISE) ARISING IN ANY WAY OUT OF THE USE OF THIS SOFTWARE, EVEN IF ADVISED OF THE POSSIBILITY OF SUCH DAMAGE.

13 The Network Time Protocol Version 4 Distribution Copyright Notice

The following copyright notice applies to all files collectively called the Network Time Protocol Version 4 Distribution. Unless specifically declared otherwise in an individual file, this notice applies as if the text was explicitly included in the file.

*

* Copyright (c) David L. Mills 1992-2001

*

* Permission to use, copy, modify, and distribute this software and
* its documentation for any purpose and without fee is hereby
* granted, provided that the above copyright notice appears in all
* copies and that both the copyright notice and this permission
* notice appear in supporting documentation, and that the name
* University of Delaware not be used in advertising or publicity
* pertaining to distribution of the software without specific,
* written prior permission. The University of Delaware makes no
* representations about the suitability this software for any
* purpose. It is provided "as is" without express or implied
* warranty.

*

14 OpenLDAP Public License Version 2.7, 7 September 2001

Redistribution and use of this software and associated documentation ("Software"), with or without modification, are permitted provided that the following conditions are met: 4.Redistributions of source code must retain copyright statements and notices, 5.Redistributions in binary form must reproduce applicable copyright statements and notices, this list of conditions, and the following disclaimer in the documentation and/or other materials provided with the distribution, and 6.Redistributions must contain a verbatim copy of this document. The OpenLDAP Foundation may revise this license from time to time. Each revision is distinguished by a version number. You may use this Software under terms of this license revision or under the terms of any subsequent revision of the license. THIS SOFTWARE IS PROVIDED BY THE OPENLDAP FOUNDATION AND ITS CONTRIBUTORS "AS IS" AND ANY EXPRESSED OR IMPLIED WARRANTIES, INCLUDING, BUT NOT LIMITED TO, THE IMPLIED WARRANTIES OF MERCHANTABILITY AND FITNESS FOR A PARTICULAR PURPOSE ARE DISCLAIMED. IN NO EVENT SHALL THE OPENLDAP FOUNDATION, ITS CONTRIBUTORS, OR THE AUTHOR(S) OR OWNER(S) OF THE SOFTWARE BE LIABLE FOR ANY DIRECT, INDIRECT, INCIDENTAL, SPECIAL, EXEMPLARY, OR CONSEQUENTIAL DAMAGES (INCLUDING, BUT NOT LIMITED TO, PROCUREMENT OF SUBSTITUTE GOODS OR SERVICES; LOSS OF USE, DATA, OR PROFITS; OR BUSINESS INTERRUPTION) HOWEVER CAUSED AND ON ANY THEORY OF LIABILITY, WHETHER IN CONTRACT, STRICT LIABILITY, OR TORT (INCLUDING NEGLIGENCE OR OTHERWISE) ARISING IN ANY WAY OUT OF THE USE OF THIS SOFTWARE, EVEN IF ADVISED OF THE POSSIBILITY OF

SUCH DAMAGE. The names of the authors and copyright holders must not be used in advertising or otherwise to promote the sale, use or other dealing in this Software without specific, written prior permission. Title to copyright in this Software shall at all times remain with copyright holders. OpenLDAP is a registered trademark of the OpenLDAP Foundation. Copyright 1999-2001 The OpenLDAP Foundation, Redwood City, California, USA. All Rights Reserved. Permission to copy and distribute verbatim copies of this document is granted.

15 OpenSSH License

The licenses which components of this software fall under are as follows. First, we will summarize and say that all components are under a BSD license, or a license more free than that. OpenSSH contains no GPL code. 1) Copyright (c) 1995 Tatu Ylonen <ylo@cs.hut.fi>, Espoo, Finland All rights reserved As far as I am concerned, the code I have written for this software can be used freely for any purpose. Any derived versions of this software must be clearly marked as such, and if the derived work is incompatible with the protocol description in the RFC file, it must be called by a name other than "ssh" or "Secure Shell". However, I am not implying to give any licenses to any patents or copyrights held by third parties, and the software includes parts that are not under my direct control. As far as I know, all included source code is used in accordance with the relevant license agreements and can be used freely for any purpose (the GNU license being the most restrictive); see below for details. [However, none of that term is relevant at this point in time. All of these restrictively licensed software components which he talks about have been removed from OpenSSH, i.e.

- RSA is no longer included, found in the OpenSSL library
- IDEA is no longer included, its use is deprecated
- DES is now external, in the OpenSSL library
- GMP is no longer used, and instead we call BN code from OpenSSL
- Zlib is now external, in a library
- The make-ssh-known-hosts script is no longer included
- TSS has been removed
- MD5 is now external, in the OpenSSL library
- RC4 support has been replaced with ARC4 support from OpenSSL
- Blowfish is now external, in the OpenSSL library

[The license continues] Note that any information and cryptographic algorithms used in this software are publicly available on the Internet and at any major bookstore, scientific library, and patent office worldwide. More information can be found e.g. at "<http://www.cs.hut.fi/crypto>". The legal status of this program is some combination of all these permissions and restrictions. Use only at your own responsibility. You will be responsible for any legal consequences yourself; I am not making any claims whether possessing or using this is legal or not in your country, and I am not taking any responsibility on your behalf.

NO WARRANTY

BECAUSE THE PROGRAM IS LICENSED FREE OF CHARGE, THERE IS NO WARRANTY FOR THE PROGRAM, TO THE EXTENT PERMITTED BY APPLICABLE LAW. EXCEPT WHEN OTHERWISE STATED IN WRITING THE COPYRIGHT HOLDERS AND/OR OTHER PARTIES PROVIDE THE PROGRAM "AS IS" WITHOUT WARRANTY OF ANY KIND, EITHER EXPRESSED OR IMPLIED, INCLUDING, BUT NOT LIMITED TO, THE IMPLIED WARRANTIES OF MERCHANTABILITY AND FITNESS FOR A PARTICULAR PURPOSE. THE ENTIRE RISK AS TO THE QUALITY AND PERFORMANCE OF THE PROGRAM IS WITH YOU. SHOULD THE PROGRAM PROVE DEFECTIVE, YOU ASSUME THE COST OF ALL NECESSARY SERVICING, REPAIR OR CORRECTION.

IN NO EVENT UNLESS REQUIRED BY APPLICABLE LAW OR AGREED TO IN WRITING WILL ANY COPYRIGHT HOLDER, OR ANY OTHER PARTY WHO MAY MODIFY AND/OR REDISTRIBUTE THE PROGRAM AS PERMITTED ABOVE, BE LIABLE TO YOU FOR DAMAGES, INCLUDING ANY GENERAL, SPECIAL, INCIDENTAL OR CONSEQUENTIAL DAMAGES ARISING OUT OF THE USE OR INABILITY TO USE THE PROGRAM (INCLUDING BUT NOT LIMITED TO LOSS OF DATA OR DATA BEING RENDERED INACCURATE OR LOSSES SUSTAINED BY YOU OR THIRD PARTIES OR A FAILURE OF THE PROGRAM TO OPERATE WITH ANY OTHER PROGRAMS), EVEN IF SUCH HOLDER OR OTHER PARTY HAS BEEN ADVISED OF THE POSSIBILITY OF SUCH DAMAGES.

2)The 32-bit CRC implementation in `crc32.c` is due to Gary S. Brown. Comments in the file indicate it may be used for any purpose without restrictions: COPYRIGHT (C) 1986 Gary S. Brown. You may use this program, or code or tables extracted from it, as desired without restriction. 3)The 32-bit CRC compensation attack detector in `deattack.c` was contributed by CORE SDI S.A. under a BSD-style license. See <http://www.core-sdi.com/english/ssh/> for details. Cryptographic attack detector for `ssh` - source code Copyright (c) 1998 CORE SDI S.A., Buenos Aires, Argentina. All rights reserved. Redistribution and use in source and binary forms, with or without modification, are permitted provided that this copyright notice is retained. THIS SOFTWARE IS PROVIDED "AS IS" AND ANY EXPRESS OR IMPLIED WARRANTIES ARE DISCLAIMED. IN NO EVENT SHALL CORE SDI S.A. BE LIABLE FOR ANY DIRECT, INDIRECT, INCIDENTAL, SPECIAL, EXEMPLARY OR CONSEQUENTIAL DAMAGES RESULTING FROM THE USE OR MISUSE OF THIS SOFTWARE. Ariel Futoransky futo@core-sdi.com <<http://www.core-sdi.com>> 4) Remaining components of the software are provided under a standard 2-term BSD license with the following names as copyright holders: Markus Friedl Theo de Raadt Niels Provos Dug Song Aaron Campbell Doug Rabson Redistribution and use in source and binary forms, with or without modification, are permitted provided that the following conditions are met: 1.Redistributions of source code must retain the above copyright notice, this list of conditions and the following disclaimer. 2.Redistributions in binary form must reproduce the above copyright notice, this list of conditions and the following disclaimer in the documentation and/or other materials provided with the distribution. THIS SOFTWARE IS PROVIDED BY THE AUTHOR "AS IS" AND ANY EXPRESS OR IMPLIED WARRANTIES, INCLUDING,

BUT NOT LIMITED TO, THE IMPLIED WARRANTIES OF MERCHANTABILITY AND FITNESS FOR A PARTICULAR PURPOSE ARE DISCLAIMED. IN NO EVENT SHALL THE AUTHOR BE LIABLE FOR ANY DIRECT, INDIRECT, INCIDENTAL, SPECIAL, EXEMPLARY, OR CONSEQUENTIAL DAMAGES (INCLUDING, BUT NOT LIMITED TO, PROCUREMENT OF SUBSTITUTE GOODS OR SERVICES; LOSS OF USE, DATA, OR PROFITS; OR BUSINESS INTERRUPTION) HOWEVER CAUSED AND ON ANY THEORY OF LIABILITY, WHETHER IN CONTRACT, STRICT LIABILITY, OR TORT (INCLUDING NEGLIGENCE OR OTHERWISE) ARISING IN ANY WAY OUT OF THE USE OF THIS SOFTWARE, EVEN IF ADVISED OF THE POSSIBILITY OF SUCH DAMAGE.

16 OpenSSL License LICENSE ISSUES

The OpenSSL toolkit stays under a dual license, i.e. both the conditions of the OpenSSL License and the original SSLeay license apply to the toolkit. See below for the actual license texts. Actually both licenses are BSD-style Open Source licenses. In case of any license issues related to OpenSSL please contact openssl-core@openssl.org. Copyright (c) 1998-2002 The OpenSSL Project. All rights reserved. Redistribution and use in source and binary forms, with or without modification, are permitted provided that the following conditions are met: 1.Redistributions of source code must retain the above copyright notice, this list of conditions and the following disclaimer. 2.Redistributions in binary form must reproduce the above copyright notice, this list of conditions and the following disclaimer in the documentation and/or other materials provided with the distribution. 3.All advertising materials mentioning features or use of this software must display the following acknowledgment: "This product includes software developed by the OpenSSL Project for use in the OpenSSL Toolkit. (<http://www.openssl.org/>)" 4.The names "OpenSSL Toolkit" and "OpenSSL Project" must not be used to endorse or promote products derived from this software without prior written permission. For written permission, please contact openssl-core@openssl.org. 5.Products derived from this software may not be called "OpenSSL" nor may "OpenSSL" appear in their names without prior written permission of the OpenSSL Project. 6.Redistributions of any form whatsoever must retain the following acknowledgment: "This product includes software developed by the OpenSSL Project for use in the OpenSSL Toolkit (<http://www.openssl.org/>)" THIS SOFTWARE IS PROVIDED BY THE OpenSSL PROJECT "AS IS" AND ANY EXPRESSED OR IMPLIED WARRANTIES, INCLUDING, BUT NOT LIMITED TO, THE IMPLIED WARRANTIES OF MERCHANTABILITY AND FITNESS FOR A PARTICULAR PURPOSE ARE DISCLAIMED. IN NO EVENT SHALL THE OpenSSL PROJECT OR ITS CONTRIBUTORS BE LIABLE FOR ANY DIRECT, INDIRECT, INCIDENTAL, SPECIAL, EXEMPLARY, OR CONSEQUENTIAL DAMAGES (INCLUDING, BUT NOT LIMITED TO, PROCUREMENT OF SUBSTITUTE GOODS OR SERVICES; LOSS OF USE, DATA, OR PROFITS; OR BUSINESS INTERRUPTION) HOWEVER CAUSED AND ON ANY THEORY OF LIABILITY, WHETHER IN CONTRACT, STRICT LIABILITY, OR TORT (INCLUDING NEGLIGENCE OR OTHERWISE) ARISING IN ANY WAY OUT OF THE USE OF THIS SOFTWARE, EVEN IF

ADVISED OF THE POSSIBILITY OF SUCH DAMAGE. This product includes cryptographic software written by Eric Young (eay@cryptsoft.com). This product includes software written by Tim Hudson (tjh@cryptsoft.com).

Original SSLeay License
Copyright (C) 1995-1998 Eric Young (eay@cryptsoft.com)
All rights reserved.

This package is an SSL implementation written by Eric Young (eay@cryptsoft.com).

The implementation was written so as to conform with Netscapes SSL. This library is free for commercial and non-commercial use as long as the following conditions are aheared to. The following conditions apply to all code found in this distribution, be it the RC4, RSA, lhash, DES, etc., code; not just the SSL code. The SSL documentation included with this distribution is covered by the same copyright terms except that the holder is Tim Hudson (tjh@cryptsoft.com). Copyright remains Eric Young's, and as such any Copyright notices in the code are not to be removed. If this package is used in a product, Eric Young should be given attribution as the author of the parts of the library used. This can be in the form of a textual message at program startup or in documentation (online or textual) provided with the package. Redistribution and use in source and binary forms, with or without modification, are permitted provided that the following conditions are met: 1.Redistributions of source code must retain the copyright notice, this list of conditions and the following disclaimer. 2.Redistributions in binary form must reproduce the above copyright notice, this list of conditions and the following disclaimer in the documentation and/or other materials provided with the distribution. 3.All advertising materials mentioning features or use of this software must display the following acknowledgement: "This product includes cryptographic software written by Eric Young (eay@cryptsoft.com)" The word 'cryptographic' can be left out if the routines from the library being used are not cryptographic related :-). 4.If you include any Microsoft Windows specific code (or a derivative thereof) from the apps directory (application code) you must include an acknowledgement: "This product includes software written by Tim Hudson (tjh@cryptsoft.com)" THIS SOFTWARE IS PROVIDED BY ERIC YOUNG "AS IS" AND ANY EXPRESS OR IMPLIED WARRANTIES, INCLUDING, BUT NOT LIMITED TO, THE IMPLIED WARRANTIES OF MERCHANTABILITY AND FITNESS FOR A PARTICULAR PURPOSE ARE DISCLAIMED. IN NO EVENT SHALL THE AUTHOR OR CONTRIBUTORS BE LIABLE FOR ANY DIRECT, INDIRECT, INCIDENTAL, SPECIAL, EXEMPLARY, OR CONSEQUENTIAL DAMAGES (INCLUDING, BUT NOT LIMITED TO, PROCUREMENT OF SUBSTITUTE GOODS OR SERVICES; LOSS OF USE, DATA, OR PROFITS; OR BUSINESS INTERRUPTION) HOWEVER CAUSED AND ON ANY THEORY OF LIABILITY, WHETHER IN CONTRACT, STRICT LIABILITY, OR TORT (INCLUDING NEGLIGENCE OR OTHERWISE) ARISING IN ANY WAY OUT OF THE USE OF THIS SOFTWARE, EVEN IF ADVISED OF THE POSSIBILITY OF SUCH DAMAGE. The license and distribution terms for any publically available version or derivative of this code cannot be changed. i.e. this code cannot simply be copied and put under another distribution license [including the GNU Public License.]

17 TZFILE Header File Declaration

This file is in the public domain, so clarified as of June 5, 1996 by Arthur David Olson (arthur_david_olson@nih.gov).

18 ZLIB Copyright Notice

(C) 1995-2002 Jean-loup Gailly and Mark Adler

This software is provided 'as-is', without any express or implied warranty. In no event will the authors be held liable for any damages arising from the use of this software. Permission is granted to anyone to use this software for any purpose, including commercial applications, and to alter it and redistribute it freely, subject to the following restrictions: 1.The origin of this software must not be misrepresented; you must not claim that you wrote the original software. If you use this software in a product, an acknowledgment in the product documentation would be appreciated but is not required. 2.Altered source versions must be plainly marked as such, and must not be misrepresented as being the original software. 3.This notice may not be removed or altered from any source distribution.

Jean-loup Gailly Mark Adler

jloup@gzip.org madler@alumni.caltech.edu

19 Sun RPC License

Sun RPC is a product of Sun Microsystems, Inc. and is provided for unrestricted use provided that this legend is included on all tape media and as a part of the software program in whole or part. Users may copy or modify Sun RPC without charge, but are not authorized to license or distribute it to anyone else except as part of a product or program developed by the user. SUN RPC IS PROVIDED AS IS WITH NO WARRANTIES OF ANY KIND INCLUDING THE WARRANTIES OF DESIGN, MERCHANTABILITY AND FITNESS FOR A PARTICULAR PURPOSE, OR ARISING FROM A COURSE OF DEALING, USAGE OR TRADE PRACTICE. Sun RPC is provided with no support and without any obligation on the part of Sun Microsystems, Inc. to assist in its use, correction, modification or enhancement. SUN MICROSYSTEMS, INC. SHALL HAVE NO LIABILITY WITH RESPECT TO THE INFRINGEMENT OF COPYRIGHTS, TRADE SECRETS OR ANY PATENTS BY SUN RPC OR ANY PART THEREOF. In no event will Sun Microsystems, Inc. be liable for any lost revenue or profits or other special, indirect and consequential damages, even if Sun has been advised of the possibility of such damages. Sun Microsystems, Inc. 2550 Garcia Avenue Mountain View, California 94043 Copyright (c) 1988 by Sun Microsystems, Inc.

20 Adaptec AIC SCSI Driver License

Copyright (c) 1994-2002 Justin T. Gibbs.

Copyright (c) 2000-2002 Adaptec Inc.

All rights reserved.

Redistribution and use in source and binary forms, with or without modification, are permitted provided that the following conditions are met: 1.Redistributions of source code must retain the above copyright notice, this list of conditions, and the following disclaimer, without modification. 2.Redistributions in binary form must reproduce at minimum a disclaimer substantially similar to the "NO WARRANTY" disclaimer

below (“Disclaimer”) and any redistribution must be conditioned upon including a substantially similar Disclaimer requirement for further binary redistribution.

3. Neither the names of the above-listed copyright holders nor the names of any contributors may be used to endorse or promote products derived from this software without specific prior written permission. Alternatively, this software may be distributed under the terms of the GNU General Public License (“GPL”) version 2 as published by the Free Software Foundation. NO WARRANTY THIS SOFTWARE IS PROVIDED BY THE COPYRIGHT HOLDERS AND CONTRIBUTORS “AS IS” AND ANY EXPRESS OR IMPLIED WARRANTIES, INCLUDING, BUT NOT LIMITED TO, THE IMPLIED WARRANTIES OF MERCHANTABILITY AND FITNESS FOR A PARTICULAR PURPOSE ARE DISCLAIMED. IN NO EVENT SHALL THE COPYRIGHT HOLDERS OR CONTRIBUTORS BE LIABLE FOR SPECIAL, EXEMPLARY, OR CONSEQUENTIAL DAMAGES (INCLUDING, BUT NOT LIMITED TO, PROCUREMENT OF SUBSTITUTE GOODS OR SERVICES; LOSS OF USE, DATA, OR PROFITS; OR BUSINESS INTERRUPTION) HOWEVER CAUSED AND ON ANY THEORY OF LIABILITY, WHETHER IN CONTRACT, STRICT LIABILITY, OR TORT (INCLUDING NEGLIGENCE OR OTHERWISE) ARISING IN ANY WAY OUT OF THE USE OF THIS SOFTWARE, EVEN IF ADVISED OF THE POSSIBILITY OF SUCH DAMAGES.

21 QLogic 2300 License

Copyright (c) 1997, 1998, 1999, 2000, 2001 by Matthew Jacob

Feral Software

All rights reserved.

Redistribution and use in source and binary forms, with or without modification, are permitted provided that the following conditions are met: 1.Redistributions of source code must retain the above copyright notice immediately at the beginning of the file, without modification, this list of conditions, and the following disclaimer. 2.The name of the author may not be used to endorse or promote products derived from this software without specific prior written permission. THIS SOFTWARE IS PROVIDED BY THE AUTHOR AND CONTRIBUTORS “AS IS” AND ANY EXPRESS OR IMPLIED WARRANTIES, INCLUDING, BUT NOT LIMITED TO, THE IMPLIED WARRANTIES OF MERCHANTABILITY AND FITNESS FOR A PARTICULAR PURPOSE ARE DISCLAIMED. IN NO EVENT SHALL THE AUTHOR OR CONTRIBUTORS BE LIABLE FOR ANY DIRECT, INDIRECT, INCIDENTAL, SPECIAL, EXEMPLARY, OR CONSEQUENTIAL DAMAGES (INCLUDING, BUT NOT LIMITED TO, PROCUREMENT OF SUBSTITUTE GOODS OR SERVICES; LOSS OF USE, DATA, OR PROFITS; OR BUSINESS INTERRUPTION) HOWEVER CAUSED AND ON ANY THEORY OF LIABILITY, WHETHER IN CONTRACT, STRICT LIABILITY, OR TORT (INCLUDING NEGLIGENCE OR OTHERWISE) ARISING IN ANY WAY OUT OF THE USE OF THIS SOFTWARE, EVEN IF ADVISED OF THE POSSIBILITY OF SUCH DAMAGE. Inspiration and ideas about this driver are from Erik Moe’s Linux driver (qlogicisp.c) and Dave Miller’s SBus version of same (qlogicisp.c). Some ideas dredged from the Solaris driver.

22 QLogic SCSI License

Copyright (c) 1997, 1998 by Matthew Jacob
NASA/Ames Research Center All rights reserved.

Redistribution and use in source and binary forms, with or without modification, are permitted provided that the following conditions are met: 1.Redistributions of source code must retain the above copyright notice immediately at the beginning of the file, without modification, this list of conditions, and the following disclaimer.

2.Redistributions in binary form must reproduce the above copyright notice, this list of conditions and the following disclaimer in the documentation and/or other materials provided with the distribution. 3.The name of the author may not be used to endorse or promote products derived from this software without specific prior written permission.

THIS SOFTWARE IS PROVIDED BY THE AUTHOR AND CONTRIBUTORS "AS IS" AND ANY EXPRESS OR IMPLIED WARRANTIES, INCLUDING, BUT NOT LIMITED TO, THE IMPLIED WARRANTIES OF MERCHANTABILITY AND FITNESS FOR A PARTICULAR PURPOSE ARE DISCLAIMED. IN NO EVENT SHALL THE AUTHOR OR CONTRIBUTORS BE LIABLE FOR ANY DIRECT, INDIRECT, INCIDENTAL, SPECIAL, EXEMPLARY, OR CONSEQUENTIAL DAMAGES (INCLUDING, BUT NOT LIMITED TO, PROCUREMENT OF SUBSTITUTE GOODS OR SERVICES; LOSS OF USE, DATA, OR PROFITS; OR BUSINESS INTERRUPTION) HOWEVER CAUSED AND ON ANY THEORY OF LIABILITY, WHETHER IN CONTRACT, STRICT LIABILITY, OR TORT (INCLUDING NEGLIGENCE OR OTHERWISE) ARISING IN ANY WAY OUT OF THE USE OF THIS SOFTWARE, EVEN IF ADVISED OF THE POSSIBILITY OF SUCH DAMAGE.

Inspiration and ideas about this driver are from Erik Moe's Linux driver (qlogiscsp.c) and Dave Miller's SBus version of same (qlogiscsp.c). Some ideas dredged from the Solaris driver.

23 QLogic ISP 2300 Initiator/Target Firmware Copyright Notice

ISP2300 Initiator/Target Firmware
with Fabric (Public Loop), Point-point, and
expanded LUN addressing for FCTAPE

NOTICE

COPYRIGHT 2001 QLOGIC CORPORATION
ALL RIGHTS RESERVED

This computer program is CONFIDENTIAL and contains TRADE SECRETS of QLOGIC CORPORATION. The receipt or possession of this program does not convey any rights to reproduce or disclose its contents, or to manufacture, use, or sell anything that it may describe, in whole or in part, without the specific written consent of QLOGIC CORPORATION.

Any reproduction of this program without the express written consent of QLOGIC CORPORATION is a violation of the copyright laws and may subject you to civil liability and criminal prosecution.

Firmware Version 3.01.20 (15:30 Dec 19, 2002)

24 Intel Corporation EM Gigabit NIC Driver License

Copyright (c) 1999-2001 Intel Corporation

All rights reserved.

Redistribution and use in source and binary forms of the Software, with or without modification, are permitted provided that the following conditions are met:

1.Redistributions of source code of the Software may retain the above copyright notice, this list of conditions and the following disclaimer. 2.Redistributions in binary form of the Software may reproduce the above copyright notice, this list of conditions and the following disclaimer in the documentation and/or other materials provided with the distribution. 3.Neither the name of the Intel Corporation nor the names of its contributors shall be used to endorse or promote products derived from this Software without specific prior written permission. THIS SOFTWARE IS PROVIDED BY THE COPYRIGHT HOLDERS AND CONTRIBUTORS "AS IS" AND ANY EXPRESS OR IMPLIED WARRANTIES, INCLUDING, BUT NOT LIMITED TO, THE IMPLIED WARRANTIES OF MERCHANTABILITY AND FITNESS FOR A PARTICULAR PURPOSE ARE DISCLAIMED. IN NO EVENT SHALL THE INTEL OR ITS CONTRIBUTORS BE LIABLE FOR ANY DIRECT, INDIRECT, INCIDENTAL, SPECIAL, EXEMPLARY, OR CONSEQUENTIAL DAMAGES (INCLUDING, BUT NOT LIMITED TO, PROCUREMENT OF SUBSTITUTE GOODS OR SERVICES; LOSS OF USE, DATA, OR PROFITS; OR BUSINESS INTERRUPTION) HOWEVER CAUSED AND ON ANY THEORY OF LIABILITY, WHETHER IN CONTRACT, STRICT LIABILITY, OR TORT (INCLUDING NEGLIGENCE OR OTHERWISE) ARISING IN ANY WAY OUT OF THE USE OF THIS SOFTWARE, EVEN IF ADVISED OF THE POSSIBILITY OF SUCH DAMAGE.

25 NIC Bonding Pseudo Device Driver

The bonding pseudo device driver contains various copyright statements:

1. Copyright 1999, Thomas Davis, tadavis@lbl.gov. Licensed under the GPL. Based on dummy.c, and eql.c devices. 2. Portions are (c) Copyright 1995 Simon "Guru Aleph-Null" Janes NCM: Network and Communications Management, Inc. BUT, I'm the one who modified it for ethernet, so: (c) Copyright 1999, Thomas Davis, tadavis@lbl.gov This software may be used and distributed according to the terms of the GNU Public License, incorporated herein by reference. 3. Author: Donald Becker becker@cesdis.gsfc.nasa.gov Copyright 1994-1996 Donald Becker This program is free software; you can redistribute it and/or modify it under the terms of the GNU General Public License as published by the Free Software Foundation. The author may be reached as becker@CESDIS.gsfc.nasa.gov, or C/O Center of Excellence in Space Data and Information Sciences Code 930.5, Goddard Space Flight Center, Greenbelt MD 20771.

Documentation and source code may be found at
<http://sourceforge.net/projects/bonding/>

26 Open source http client library

COPYRIGHT AND PERMISSION NOTICE

Copyright (c) 1996 - 2005, Daniel Stenberg, <daniel@haxx.se>.

All rights reserved.

Permission to use, copy, modify, and distribute this software for any purpose with or without fee is hereby granted, provided that the above copyright notice and this permission notice appear in all copies.

THE SOFTWARE IS PROVIDED "AS IS", WITHOUT WARRANTY OF ANY KIND, EXPRESS OR IMPLIED, INCLUDING BUT NOT LIMITED TO THE WARRANTIES OF MERCHANTABILITY, FITNESS FOR A PARTICULAR PURPOSE AND NONINFRINGEMENT OF THIRD PARTY RIGHTS. IN NO EVENT SHALL THE AUTHORS OR COPYRIGHT HOLDERS BE LIABLE FOR ANY CLAIM, DAMAGES OR OTHER LIABILITY, WHETHER IN AN ACTION OF CONTRACT, TORT OR OTHERWISE, ARISING FROM, OUT OF OR IN CONNECTION WITH THE SOFTWARE OR THE USE OR OTHER DEALINGS IN THE SOFTWARE.

Except as contained in this notice, the name of a copyright holder shall not be used in advertising or otherwise to promote the sale, use or other dealings in this Software without prior written authorization of the copyright holder.

27 Open source XML parsing library

Copyright (c) 1998, 1999, 2000 Thai Open Source Software Center Ltd

Permission is hereby granted, free of charge, to any person obtaining a copy of this software and associated documentation files (the "Software"), to deal in the Software without restriction, including without limitation the rights to use, copy, modify, merge, publish, distribute, sublicense, and/or sell copies of the Software, and to permit persons to whom the Software is furnished to do so, subject to the following conditions:

The above copyright notice and this permission notice shall be included in all copies or substantial portions of the Software.

THE SOFTWARE IS PROVIDED "AS IS", WITHOUT WARRANTY OF ANY KIND, EXPRESS OR IMPLIED, INCLUDING BUT NOT LIMITED TO THE WARRANTIES OF MERCHANTABILITY, FITNESS FOR A PARTICULAR PURPOSE AND NONINFRINGEMENT.

IN NO EVENT SHALL THE AUTHORS OR COPYRIGHT HOLDERS BE LIABLE FOR ANY CLAIM, DAMAGES OR OTHER LIABILITY, WHETHER IN AN ACTION OF CONTRACT, TORT OR OTHERWISE, ARISING FROM, OUT OF OR IN CONNECTION WITH THE SOFTWARE OR THE USE OR OTHER DEALINGS IN THE SOFTWARE.

Glossary

AC	(alternating current) (n.) Power supplied to the computer through an electrical outlet.
active cluster	(n.) A pair of identical high-availability servers that offer NAS services to client communities. In the event of a failure, the surviving server takes on the services and client community of its failed peer.
array	(n.) The storage system that attaches to the Sun StorageTek 5320 NAS Appliance or the Sun StorageTek 5320 NAS Cluster Appliance. The array consists of one or two Sun StorEdge 5300 RAID Controller Enclosures (CUs) that, optionally, can be connected to up to six Sun StorEdge 5300 Expansion Enclosures (EUs). An array can contain a mixture of EUs containing all Fibre Channel or all SATA disk drives.
AWG	(American wire gauge) (n.) A unit for measuring the thickness of wire.
cluster	(n.) A pair of identical servers providing redundant high-availability NAS services with failover protection.
configuration	(1) (n.) The manner in which the software and hardware of an information processing system are organized and interconnected. (2) (n.) The physical and logical arrangement of programs and devices that make up a data processing system. (3) (n.) The devices and programs that make up a system, subsystem, or network.
DC	(direct current) (n.) Power typically supplied through a DC adapter or battery.
driver	(n.) A software program that enables a computer to communicate with a peripheral device. Examples include a SCSI driver, a CD-ROM driver, and printer drivers.
dual head	(adj.) A reference to a pair of clustered servers. Servers can be referred to as "heads."
failure	(n.) A detectable physical change in hardware or software that disrupts normal (proper) operation. A failure is repaired by the replacement of a physical component or software.

Fast Ethernet (single and multiport)	(n.) A high-speed version of Ethernet transmitting data at 100 Mbps. Fast Ethernet networks use the same media access control method that 10BASE-T Ethernet networks use but achieve 10 times the data transmission speed.
flash memory	(n.) A special type of read-only memory (ROM) that enables users to upgrade the information contained in the memory chips.
gateway	(1) (n.) A way of accessing a network. (2) (n.) A configuration that enables a NAS server to share storage over a network.
GB	(gigabyte) (n.) A unit of information equal to 1024 megabytes.
Gigabit Ethernet	(n.) An Ethernet technology that enables data transfer rates of up to 1 Gbps using optical fiber cable or unshielded twisted-pair cable.
hot-swap	(v.) To replace a failed component without interruption of system service.
interface cable	(n.) A cable designed to connect a computer to a peripheral device, or a peripheral device to another peripheral device, allowing each device to communicate with the other.
KB	(kilobyte) (n.) A unit of information equal to 1024 bytes.
LCD	(liquid crystal display) (n.) A low-power display technology that uses rod-shaped crystal molecules that change their orientation when an electrical current flows through them.
LED	(light-emitting diode) (n.) A semiconductor device that converts electrical energy into light.
MB	(megabyte) (n.) A unit of information equivalent to 1,048,576 bytes or 1024 kilobytes. Most uses of “megabyte,” however, refer to exactly 1 million bytes.
MHz	(megahertz) (n.) A measure of frequency equivalent to 1 million cycles per second.
motherboard	(n.) A large circuit board that contains the computer’s central processing unit (CPU), microprocessor support chips, random-access memory (RAM), and expansion slots.
MTBF	(Mean Time Between Failures) (n.) The estimated time a device operates before a failure occurs.
NAS	(network-attached storage) (n.) A storage appliance that connects directly to the network. NAS does not usually perform network directory services or function as an application server; instead, it augments storage capacities. Quick and easy to set up, NAS appliances also typically provide cross-platform file sharing.
NIC	(network interface card) (n.) An adapter that lets you connect a network cable to a microcomputer. The card includes encoding and decoding circuitry and a receptacle for a network cable connection.

parity	(adj.) Refers to data created by combining the bits in the information to be stored and creating a small amount of data from which the rest of the information can be extracted.
RAID	(Redundant Array of Independent Disks) (n.) A group of hard disks under the control of array management software that work together to improve performance and decrease the odds of losing data to mechanical or electronic failure by using techniques such as data striping.
RAID-5	(n.) The most commonly used RAID implementation. RAID-5 uses striping and parity information.
RAM	(random access memory) (n.) Semiconductor-based memory that can be read and written by the microprocessor or other hardware devices. Generally understood to refer to volatile memory, which can be written as well as read.
SAN	(storage area network) (n.) A network that includes various storage devices shared by multiple servers.
SCSI	(Small Computer Systems Interface) (n.) A standard interface for PCs that enables you to connect up to 15 peripheral devices, such as CD-ROM drives.
SCSI bus	(n.) A pathway between SCSI hardware devices.
SCSI host adapter	(n.) A printed circuit board (also called an interface card) that enables the computer to use a peripheral device for which it does not already have the necessary connections or circuit boards.
SCSI ID	(n.) Priority number (address) of a SCSI device in a SCSI device chain. Only one device at a time can transmit through a SCSI connection (port), and priority is given to the device with the highest priority address. SCSI IDs range from 0 to 15, and each SCSI device must be given a unique and unused SCSI ID.
single head	(adj.) A reference to a single server or "head."
SMB	(server message block) (n.) A Microsoft-compatible network protocol for exchanging files. SMB is typically used by Microsoft Windows for Workgroups, OS/2 Warp Connect, and DEC Pathworks.
striping	(n.) A RAID-based method for data storage in which data is divided into "stripes." One stripe is written to the first drive, the next to the second drive, and so on. The primary advantage of striping is the ability for all drives in the array to process reads and writes simultaneously.
termination	(n.) The electrical connection at each end of the SCSI bus, composed of a set of resistors on internal SCSI devices or an active or passive SCSI terminator block on external SCSI devices.

Index

A

- administrator console, 11
- appliance, *See* Sun StorageTek 5320 NAS Appliance
- arrays
 - Sun StorageTek 6130 array, 173 to 178
 - Sun StorageTek 6130/6140 array, 114
 - Sun StorageTek FlexLine 200 and 300 Series array, 126
 - Sun StorEdge 6920 system, 135
 - Sun StorEdge 99xx system, 145

B

- back-end storage
 - cabling
 - appliances, 54 to 66
 - cluster appliances, 84 to 97
 - overview, 7, 9
- boot sequence log, 82

C

- cabinet
 - installing a tray, 29
- cabinets, 14
 - order of installation, 20 to 22
 - preparation, 20
 - server installation, 33 to 49
- cable management assembly, installation, 42 to 49
- cabling
 - back-end storage to appliances, 54 to 66
 - back-end storage to cluster appliances, 84 to 97
 - controller units to appliances, 54
 - controller units to cluster appliances, 84

- expansion units to controller units, 59 to 66, 90 to 97
- SAN storage to gateway systems, 111 to 156
- Sun StorageTek 6130/6140 array, 114
- Sun StorEdge 6920 system, 135
- Sun StorEdge 99xx system, 145
- clients, 3
- cluster appliance, *See* Sun StorageTek 5320 NAS Cluster Appliance
- cluster configuration, serial number, 22
- cluster configuration, serial numbers, 6
- cluster gateway system, *See* Sun StorageTek 5320 NAS Cluster Gateway System
- CMA (cable management assembly), installation, 42 to 49
- configuration
 - appliance systems, 78 to 82
 - cluster appliances, 105 to 109
 - cluster gateway systems, 166 to 173
 - gateway systems, 159
 - LUNs
 - cluster appliances, 108 to 109
 - cluster gateway systems, 170 to 173
 - options, 7
 - SAN storage, 173 to 179
 - storage
 - gateway systems, 164
- connections
 - back-end storage to appliances, 54 to 66
 - back-end storage to cluster appliances, 84 to 97
 - controller units to appliances, 54
 - controller units to cluster appliances, 84

- controller units to expansion units, 59 to 66, 90 to 97
- health-monitoring cable
 - cluster appliances, 98
 - cluster gateway systems, 155 to 156
- network, 3
 - appliances, 73 to 74
 - cluster appliances, 98 to 99
 - gateway systems, 154 to 156
- power, 17
- SAN storage to gateway systems, 111 to 156
- Sun StorageTek 6130/6140 array, 114
- Sun StorEdge 6920 system, 135
- Sun StorEdge 99xx system, 145

controller units

- cabling
 - appliances, 54
 - cluster appliances, 84
 - expansion units, 59 to 66, 90 to 97
- configuration, 78 to 82, 105 to 109
- installation
 - preparation, 19
- installation order, 20 to 22
- overview, 7
- powering on, 74 to 78, 100 to 105

D

- direct attach connections, 114

E

- electrical grounding, 16 to 17
- expansion units
 - cabling
 - controller units, 59 to 66, 90 to 97
 - configuration, 78 to 82, 105 to 109
 - installation
 - preparation, 19
 - installation order, 20 to 22
 - overview, 8
 - powering on, 74 to 78, 100 to 105

F

- fabric attach connections, 114
- Fast Ethernet
 - appliances, 73
 - cluster appliances, 99
 - cluster gateway systems, 156
 - gateway systems, 154

G

- gateway system, *See* Sun StorageTek 5320 NAS Gateway System
- Gigabit Ethernet
 - appliances, 73
 - cluster appliances, 99
 - cluster gateway systems, 156
 - gateway systems, 154
 - optical
 - appliances, 73
 - cluster appliances, 98
 - cluster gateway systems, 156
 - gateway systems, 155
- grounding
 - rack installation, 17
 - requirements, 16 to 17

H

- hardware overview, 4 to 9
- health-monitoring cable
 - cluster appliances, 98
 - cluster gateway systems, 155 to 156
- heartbeat, 98
- heartbeat, *See* health-monitoring cable

I

- installation
 - cabinets, 14
 - CMA, 42 to 49
 - grounding, 17
 - in cabinets, 20 to 49
 - mounting brackets, 34 to 42
 - order, 20 to 22
 - power cables, 51
 - preparation, 15 to 20
 - racks, 14
 - rail kits, 14 to 15
 - servers, 33 to 49
 - preparation, 18
 - slide rail assemblies, 34 to 42
 - verification, 46 to 49
- installing a tray in a cabinet, 29
- IP address configuration
 - appliances, 79
 - cluster appliances, 105 to 106
 - cluster gateway systems, 166
 - gateway systems, 159

L

- licensed options, 11
- local log, setting up, 82
- LUNs
 - cluster appliance configuration, 108 to 109
 - cluster gateway system configuration, 170 to 173

M

- mains AC power disconnect, 17
- mounting brackets, installation, 34 to 42

N

- network connections, 3
 - appliances, 73 to 74
 - cluster appliances, 98 to 99
 - gateway systems, 154 to 156

O

- optical Gigabit Ethernet
 - appliances, 73
 - cluster appliances, 98
 - cluster gateway systems, 156
 - gateway systems, 155

options

- licensed, 11
- server, 7

overview

- appliances, 5 to 6
- back-end storage, 7, 9
- cluster appliances, 6
- controller units, 7
- expansion units, 8
- gateway systems, 7
- hardware, 4 to 9
- servers, 5 to 7
- software, 10 to 11
- system, 1 to 11

P

power

- connections, 17
- disconnecting, 17
- on appliance systems, 74 to 78
- on cluster appliances, 100 to 105
- on gateway systems, 156 to 158

power

- on cluster appliances, 105

power cables

- connecting, 51

preparation for installation

- cabinets, 20
- controller units, 19
- expansion units, 19
- universal rail kit, 18

protocols, 2

R

rack installation

- cabinets, 20 to 49
- grounding, 17
- preparation, 15 to 20
- requirements, 14

rackmount kit preparation, 18

rackmount kits

- preparation, 18

racks, 14

rail installation

- servers, 33 to 49

rail kits, 14 to 15

- universal, 18

requirements

- grounding, 16 to 17
- rack, 14
- software, 10

S

SAN storage, 9, 111

cabling

- gateway systems, 111 to 156

configuration, 173 to 179

direct attach, 114

fabric attach, 114

Sun StorageTek 6130/6140 array, 114

Sun StorEdge 6920 system, 135

Sun StorEdge 99xx system, 145

security, 2

serial number, software, 5, 6, 22

servers

- heartbeat, *See* health-monitoring cable

installation, 33 to 49

- order, 20 to 22

preparation, 18

options, 7

overview, 5 to 7

- slide rail assemblies
 - installation, 34 to 42
 - verification, 46 to 49
- software
 - configuration
 - appliance systems, 78 to 82
 - cluster appliances, 105 to 109
 - cluster gateway systems, 166 to 173
 - gateway systems, 159
 - overview, 10 to 11
 - requirements, 10
 - supported, 10
 - Web Administrator
 - appliance configuration, 80 to 82
 - cluster appliance configuration, 107 to 108
 - cluster gateway system configuration, 167 to 170
 - gateway system configuration, 160 to 163
- software serial number, 5, 6, 22
- storage, *See* back-end storage, SAN storage
- Sun StorageTek 5320 Expansion Unit, *See* expansion units
- Sun StorageTek 5320 NAS Appliance
 - configuration, 78 to 82
 - Fast Ethernet, 73
 - Gigabit Ethernet, 73
 - optical, 73
 - network connections, 73 to 74
 - overview, 5 to 6
 - powering on, 74 to 78
- Sun StorageTek 5320 NAS Cluster Appliance
 - configuration, 105 to 109
 - LUNs, 108 to 109
 - Web Admin, 107 to 108
 - Fast Ethernet, 99
 - Gigabit Ethernet, 99
 - optical, 98
 - health-monitoring cable, 98
 - IP address configuration, 105 to 106
 - network connections, 98 to 99
 - overview, 6
 - powering on, 100 to 105
- Sun StorageTek 5320 NAS Cluster Gateway System
 - configuration, 166 to 173
 - LUNs, 170 to 173
 - Web Admin, 167 to 170
 - Fast Ethernet, 156
 - Gigabit Ethernet
 - optical, 156
 - health-monitoring cable, 155 to 156
 - IP address configuration, 166
 - See also* Sun StorageTek 5320 NAS Gateway System
- Sun StorageTek 5320 NAS Gateway System
 - cabling to SAN storage, 111 to 156
 - configuration, 159
 - storage, 164
 - Fast Ethernet, 154
 - Gigabit Ethernet
 - optical, 155
 - network connections, 154 to 156
 - overview, 7
 - powering on, 156 to 158
 - Sun StorageTek 6130/6140 array, 114
 - Sun StorageTek FlexLine 200 and 300 Series, 126
 - Sun StorEdge 6920 system, 135
 - Sun StorEdge 99xx system, 145
- Sun StorageTek 5320 RAID Controller Unit, *See* controller unit
- Sun StorageTek 6130/6140 array, 114
- Sun StorageTek 6140 array
 - storage configuration, 178
- Sun StorageTek Compliance Archiving Software, 11
- Sun StorageTek File Replicator, 11
- Sun StorageTek FlexLine 200 and 300 Series, 126
- Sun StorEdge 6920 system, 135
 - storage configuration, 178
- Sun StorEdge 99xx system, 145
- supported clients, 3
- system
 - overview, 1 to 11
 - software requirements, 10

T

- tray
 - installing, 29
- tray installation
 - preparing the rackmount kit for, 18

U

- universal rail kit, 15
 - attaching to a cabinet, 23
 - preparation, 18

W

Web Admin, 10

Web Administrator

- appliance configuration, 80 to 82

- cluster appliance configuration, 107 to 108

- cluster gateway system configuration, 167 to 170

- gateway system configuration, 160 to 163

