

SPARC T3-2 Server

Installation Guide



Part No.: E21590-02
March 2012

Copyright © 2010, 2012, Oracle and/or its affiliates. All rights reserved.

This software and related documentation are provided under a license agreement containing restrictions on use and disclosure and are protected by intellectual property laws. Except as expressly permitted in your license agreement or allowed by law, you may not use, copy, reproduce, translate, broadcast, modify, license, transmit, distribute, exhibit, perform, publish, or display any part, in any form, or by any means. Reverse engineering, disassembly, or decompilation of this software, unless required by law for interoperability, is prohibited.

The information contained herein is subject to change without notice and is not warranted to be error-free. If you find any errors, please report them to us in writing.

If this is software or related software documentation that is delivered to the U.S. Government or anyone licensing it on behalf of the U.S. Government, the following notice is applicable:

U.S. GOVERNMENT RIGHTS Programs, software, databases, and related documentation and technical data delivered to U.S. Government customers are "commercial computer software" or "commercial technical data" pursuant to the applicable Federal Acquisition Regulation and agency-specific supplemental regulations. As such, the use, duplication, disclosure, modification, and adaptation shall be subject to the restrictions and license terms set forth in the applicable Government contract, and, to the extent applicable by the terms of the Government contract, the additional rights set forth in FAR 52.227-19, Commercial Computer Software License (December 2007). Oracle America, Inc., 500 Oracle Parkway, Redwood City, CA 94065.

This software or hardware is developed for general use in a variety of information management applications. It is not developed or intended for use in any inherently dangerous applications, including applications which may create a risk of personal injury. If you use this software or hardware in dangerous applications, then you shall be responsible to take all appropriate fail-safe, backup, redundancy, and other measures to ensure its safe use. Oracle Corporation and its affiliates disclaim any liability for any damages caused by use of this software or hardware in dangerous applications.

Oracle and Java are registered trademarks of Oracle and/or its affiliates. Other names may be trademarks of their respective owners.

AMD, Opteron, the AMD logo, and the AMD Opteron logo are trademarks or registered trademarks of Advanced Micro Devices. Intel and Intel Xeon are trademarks or registered trademarks of Intel Corporation. All SPARC trademarks are used under license and are trademarks or registered trademarks of SPARC International, Inc. UNIX is a registered trademark licensed through X/Open Company, Ltd.

This software or hardware and documentation may provide access to or information on content, products, and services from third parties. Oracle Corporation and its affiliates are not responsible for and expressly disclaim all warranties of any kind with respect to third-party content, products, and services. Oracle Corporation and its affiliates will not be responsible for any loss, costs, or damages incurred due to your access to or use of third-party content, products, or services.

Copyright © 2010, 2012 Oracle et/ou ses affiliés. Tous droits réservés.

Ce logiciel et la documentation qui l'accompagne sont protégés par les lois sur la propriété intellectuelle. Ils sont concédés sous licence et soumis à des restrictions d'utilisation et de divulgation. Sauf disposition de votre contrat de licence ou de la loi, vous ne pouvez pas copier, reproduire, traduire, diffuser, modifier, breveter, transmettre, distribuer, exposer, exécuter, publier ou afficher le logiciel, même partiellement, sous quelque forme et par quelque procédé que ce soit. Par ailleurs, il est interdit de procéder à toute ingénierie inverse du logiciel, de le désassembler ou de le décompiler, excepté à des fins d'interopérabilité avec des logiciels tiers ou tel que prescrit par la loi.

Les informations fournies dans ce document sont susceptibles de modification sans préavis. Par ailleurs, Oracle Corporation ne garantit pas qu'elles soient exemptes d'erreurs et vous invite, le cas échéant, à lui en faire part par écrit.

Si ce logiciel, ou la documentation qui l'accompagne, est concédé sous licence au Gouvernement des Etats-Unis, ou à toute entité qui délivre la licence de ce logiciel ou l'utilise pour le compte du Gouvernement des Etats-Unis, la notice suivante s'applique:

U.S. GOVERNMENT RIGHTS. Programs, software, databases, and related documentation and technical data delivered to U.S. Government customers are "commercial computer software" or "commercial technical data" pursuant to the applicable Federal Acquisition Regulation and agency-specific supplemental regulations. As such, the use, duplication, disclosure, modification, and adaptation shall be subject to the restrictions and license terms set forth in the applicable Government contract, and, to the extent applicable by the terms of the Government contract, the additional rights set forth in FAR 52.227-19, Commercial Computer Software License (December 2007). Oracle America, Inc., 500 Oracle Parkway, Redwood City, CA 94065.

Ce logiciel ou matériel a été développé pour un usage général dans le cadre d'applications de gestion des informations. Ce logiciel ou matériel n'est pas conçu ni n'est destiné à être utilisé dans des applications à risque, notamment dans des applications pouvant causer des dommages corporels. Si vous utilisez ce logiciel ou matériel dans le cadre d'applications dangereuses, il est de votre responsabilité de prendre toutes les mesures de secours, de sauvegarde, de redondance et autres mesures nécessaires à son utilisation dans des conditions optimales de sécurité. Oracle Corporation et ses affiliés déclinent toute responsabilité quant aux dommages causés par l'utilisation de ce logiciel ou matériel pour ce type d'applications.

Oracle et Java sont des marques déposées d'Oracle Corporation et/ou de ses affiliés. Tout autre nom mentionné peut correspondre à des marques appartenant à d'autres propriétaires qu'Oracle.

AMD, Opteron, le logo AMD et le logo AMD Opteron sont des marques ou des marques déposées d'Advanced Micro Devices. Intel et Intel Xeon sont des marques ou des marques déposées d'Intel Corporation. Toutes les marques SPARC sont utilisées sous licence et sont des marques ou des marques déposées de SPARC International, Inc. UNIX est une marque déposée concédée sous licence par X/Open Company, Ltd.

Ce logiciel ou matériel et la documentation qui l'accompagne peuvent fournir des informations ou des liens donnant accès à des contenus, des produits et des services émanant de tiers. Oracle Corporation et ses affiliés déclinent toute responsabilité ou garantie expresse quant aux contenus, produits ou services émanant de tiers. En aucun cas, Oracle Corporation et ses affiliés ne sauraient être tenus pour responsables des pertes subies, des coûts occasionnés ou des dommages causés par l'accès à des contenus, produits ou services tiers, ou à leur utilisation.



Adobe PostScript

Contents

Using This Documentation	vii
Preparing for the Installation	1
Installation Task Overview	2
Server Overview	3
Confirming Server Specifications	5
Physical Specifications	5
Electrical Specifications	6
Input Power Information	7
Environmental Requirements	8
Acoustic Noise Emissions	9
Cooling Zones and Airflow Clearance	9
Shipping Kit Inventory List	11
Front Panel Components	12
Back Panel Components	13
Server Handling Precautions	14
ESD Precautions	15
Tools Needed for Installation	16
Optional Component Installation	16
Installing the Server	17
Rack Compatibility	18
▼ Stabilize the Rack for Installation	20

- ▼ Disassemble Slide Rails 20
- ▼ Install Mounting Brackets 22
- ▼ Attach Slide Rail Assemblies 23
- ▼ Install Server Into the Slide Rail Assemblies 26
- ▼ Install the CMA 28
- ▼ Verify Operation of Slide Rails and CMA 33

Connecting the Server Cables 35

- Cabling Requirements 36
- Rear Panel Connectors and Ports 37
 - ▼ Connect the SER MGT Cable 39
 - ▼ Connect the NET MGT Cable 40
 - ▼ Connect the Ethernet Network Cables 41
 - ▼ Connect the Network Module Cables 42
 - ▼ Connect Other Data Cables 46
 - ▼ Prepare the Power Cords 46
 - ▼ Secure Cables to CMA 47

Powering On the Server for the First Time 49

- Power On Tasks 50
- ILOM System Console 50
 - ▼ Connect a Terminal or Emulator to the SER MGT Port 51
 - ▼ Power On the System for the First Time 52
- Oracle Solaris OS Configuration Parameters 55
 - ▼ Assign a Static IP Address to the SP 57

Identifying the Server Ports 61

- USB Ports 62
- SER MGT Port 63
- NET MGT Port 64

Gigabit Ethernet Ports 65

Video Ports 66

SAS Connectors 67

QSFP Port 69

Glossary 71

Index 75

Using This Documentation

This service manual explains how to diagnose hardware problems and replace parts in the SPARC T3-2 server from Oracle. This document is written for technicians, system administrators, authorized service providers, and users who have advanced experience troubleshooting and replacing hardware.

- “Product Notes” on page vii
- “Related Documentation” on page viii
- “Feedback” on page viii
- “Support and Accessibility” on page ix

Product Notes

For late-breaking information and known issues about this product, refer to the product notes at:

<http://www.oracle.com/pls/topic/lookup?ctx=E19166-01>

Related Documentation

Documentation	Links
All Oracle products	http://www.oracle.com/documentation
SPARC T3-2 server	http://www.oracle.com/pls/topic/lookup?ctx=E19166-01
Oracle ILOM 3.0	http://www.oracle.com/pls/topic/lookup?ctx=ilom30
Oracle Solaris OS and other systems software	http://www.oracle.com/technetwork/indexes/documentation/#sys_sw
Oracle VTS 7.0	http://www.oracle.com/pls/topic/lookup?ctx=E19719-01

Feedback

Provide feedback on this documentation at:

<http://www.oracle.com/goto/docfeedback>

Support and Accessibility

Description	Links
Access electronic support through My Oracle Support	http://support.oracle.com
	For hearing impaired: http://www.oracle.com/accessibility/support.html
Learn about Oracle's commitment to accessibility	http://www.oracle.com/us/corporate/accessibility/index.html

Preparing for the Installation

These topics provides background information about the server's installation procedures.

- "Installation Task Overview" on page 2
- "Server Overview" on page 3
- "Confirming Server Specifications" on page 5
- "Shipping Kit Inventory List" on page 11
- "Front Panel Components" on page 12
- "Back Panel Components" on page 13
- "Server Handling Precautions" on page 14
- "ESD Precautions" on page 15
- "Tools Needed for Installation" on page 16
- "Optional Component Installation" on page 16

Related Information

- "Installing the Server" on page 17
- "Connecting the Server Cables" on page 35
- "Powering On the Server for the First Time" on page 49

Installation Task Overview

Perform the following tasks to install and configure the server.

Step	Description	Links
1	Review the <i>SPARC T3-2 Server Product Notes</i> for any late-breaking news about the server.	<i>SPARC T3-2 Server Product Notes</i>
2	Review the server features, specifications, and site requirements.	"Server Overview" on page 3 "Confirming Server Specifications" on page 5
3	Confirm you received all of the items you ordered.	"Shipping Kit Inventory List" on page 11
4	Familiarize yourself with the server features, controls, and LEDs required for installation.	"Front Panel Components" on page 12 "Back Panel Components" on page 13
5	Take safety and ESD precautions and assemble the required tools.	"Server Handling Precautions" on page 14 "ESD Precautions" on page 15 "Tools Needed for Installation" on page 16
6	Install any optional component into the server.	"Optional Component Installation" on page 16
7	Install the server into a rack.	"Installing the Server" on page 17
8	Attach data and management cables to the server.	"Connecting the Server Cables" on page 35
9	Connect the power cords to the server, configure the Oracle ILOM service processor, power on the server for the first time, and set up the operating system.	"Powering On the Server for the First Time" on page 49

Related Information

- *SPARC T3-2 Server Product Notes*
- *SPARC T3-2 Server Safety and Compliance Guide*
- *SPARC T3 Series Servers Administration Guide*
- *SPARC T3-2 Server Service Manual*

Server Overview

This topic describes the main components and capabilities of the server.



Component	Description
CPU	Two processors installed on the motherboard assembly.
Memory	Up to four memory riser modules are supported (two risers per CPU). <ul style="list-style-type: none">• Each riser module supports 8 DIMMs, allowing up to 16 DIMMs per processor.• A server using four riser modules fully populated with 8-GB DIMMs supports a maximum of 256 GB of system memory.
Storage devices	For internal storage, the server provides: <ul style="list-style-type: none">• Six 2.5-inch drive bays, accessible through the front panel.• An optional slot-loading DVD+/-RW drive on front of the server, below the drive bays.• One internal high-speed USB port on the motherboard. This port can hold a USB flash device for system booting.
USB 2.0 ports	Two front, two rear, and one internal ports.
Video ports	One front and one rear high-density DB-15 video ports.

Component	Description
PCI Express 2.0 I/O slots	Ten PCI Express 2.0 slots that accommodate low-profile PCIe cards. All slots support x8 PCIe cards. Two slots are also capable of supporting x16 PCIe cards. <ul style="list-style-type: none"> • Slots 4 and 5: x4 electrical interface • Slots 0, 1, 2, 7, 8, and 9: x8 electrical interface • Slots 3 and 6: x8 electrical interface (x16 connector)
Network module slot	One specialized slot dedicated for use with the SPARC T3-2 Server 10 Gb Network Module card. The server does not support populating this slot with standard PCIe cards.
Ethernet ports	Four 10/100/1000 RJ-45 GbE ports on rear panel.
Service processor	The service processor supports the following features: <ul style="list-style-type: none"> • Integrated BMC, which supports the industry-standard IPMI feature set. • Supports remote KVMS, DVD, and floppy over IP. • Includes a serial port. • Supports Ethernet access to SP through a dedicated 10/100BaseT management port and optionally through one of the host GbE ports (using Oracle ILOM sideband management).
Power supplies	Two hot-swappable power supplies, each with autoranging, light load efficiency mode and redundant oversubscription.
Cooling fans	Six hot-swappable, redundant fans at chassis front (top-loading); redundant fans in each power supply.
Management software	Oracle ILOM.

Related Information

- *SPARC T3-2 Server Service Manual*
- Oracle ILOM documentation
- [“Front Panel Components” on page 12](#)
- [“Back Panel Components” on page 13](#)

Confirming Server Specifications

Prior to installing the server, review the server specifications and prepare the installation site.

- [“Physical Specifications” on page 5](#)
- [“Electrical Specifications” on page 6](#)
- [“Input Power Information” on page 7](#)
- [“Environmental Requirements” on page 8](#)
- [“Acoustic Noise Emissions” on page 9](#)
- [“Cooling Zones and Airflow Clearance” on page 9](#)

Related Information

- [“Server Overview” on page 3](#)
- [“Shipping Kit Inventory List” on page 11](#)
- [“Identifying the Server Ports” on page 61](#)

Physical Specifications

Note – To permit safe installation and servicing, provide 36 in. (91 cm) clearance in front and rear of the server.

Dimension	Value
Height	5.11 inches / 129.85 mm
Width	17.19 inches / 436.5 mm
Depth	28.82 inches / 732 mm
Weight	80 lbs max, 58 lbs min / 36.28 kg, 26.31 kg min
Minimum service access clearance (front)	36 in. / 91 cm
Minimum service access clearance (rear)	36 in. / 91 cm

Related Information

- [“Shipping Kit Inventory List” on page 11](#)

- “Installing the Server” on page 17

Electrical Specifications

The following table lists the maximum ratings for the power supplies used in the server. The listed power numbers are *not* the actual rated power consumption of the system.

Use the online power calculator to determine the power consumption of a server with your configuration. To locate the appropriate power calculator, go to the following web site and navigate to the SPARC T3-2 server page:

<http://www.oracle.com/goto/powercalculators/>

Note – Plan to connect each power supply to a separate circuit if possible. This redundancy enables the server to remain operational if one of the circuits fails. Consult your local electrical codes for any additional requirements.

Parameter	Value
Input	
Nominal frequencies	50 / 60 Hz
Nominal AC operating voltage range	200 to 240 VAC
Maximum current AC RMS per power cord	12 A @ 200 VAC
Volt-Ampere rating	2218 VA @ 240 VAC
Power factor	0.98 P.F. @ 240 VAC, full load
Power dissipation	
Max power consumption of power supply	2175 W
Max heat output	7417 BTU/hr
Inrush current (peak)	25 A
Leakage current	1.6 mA
Output	
3.3 VDC STBY	10 A
+12 VDC	165 A

Related Information

- [“Input Power Information” on page 7](#)
- [“Prepare the Power Cords” on page 46](#)
- [“Powering On the Server for the First Time” on page 49](#)

Input Power Information

The server provides redundant, hot-swappable power supplies. When each power supply is connected to a separate power source, the server continues to operating under the following fault conditions:

- A power source failure that removes input power from one of the power supplies.
- Failure of one of the power supplies.
- Service actions which require removal of one of the power supplies.

Refer to the *SPARC T3-2 Server Service Manual* for power supply replacement instructions.

Note – Input power cables: To avoid missing initialization messages, do not attach power cables to the power supplies until you have finished connecting the data cables and have connected the server to a serial terminal or a terminal emulator (PC or workstation). The server goes into Standby mode and the Oracle ILOM service processor initializes as soon as the input power cables are connected to the power source.

Related Information

- *SPARC T3-2 Server Service Manual*
- [“Electrical Specifications” on page 6](#)
- [“Prepare the Power Cords” on page 46](#)

Environmental Requirements

Install and operate the server in a site with an ambient temperature range of 21°C (69.8°F) to 23°C (73.4°F), which is an optimal range for server reliability. At 22°C (71.6°F) it is easy to maintain safe relative humidity levels. Operating in this temperature range provides a buffer if the environmental support systems fail.

Operating the server in a site with ambient relative humidity levels between 45% and 50% prevents corrosion, provides an operating time buffer in the event of environmental control system failure, and helps avoid failures caused by static discharges that occur when relative humidity is too low.

Note – Electrostatic discharge is easily generated and less easily dissipated in areas where the relative humidity is below 35%, and becomes critical when levels drop below 30%.

The server has been tested to meet all functional requirements when operating in the operating environmental limits listed in the table below (all values are for a single, non-rackmounted server).

Parameter	Value
Operating temperature	5°C to 35°C (41°F to 95°F)
Non-operating temperature	-40°C to 65°C (-40°F to 149°F)
Operating humidity	10% to 90% relative humidity, 27°C (80.6°F) maximum web bulb, noncondensing
Non-operating humidity	Up to 93% relative humidity, 38°C (100.4°F) maximum web bulb, noncondensing
Operating altitude	Up to 3000 m (10,000 ft), maximum ambient temperature is derated by 2 degrees C for every 1 km (3.6 degree F per 3,280 ft)
Non-operating altitude	Up to 12,000 m (40,000 ft)
Operating vibration	0.15 G (vertical), 0.10 G (horizontal), 5 – 500 Hz, swept-sine
Non-operating vibration	0.5 G (vertical), 0.25 G (horizontal), 5 – 500 Hz, swept-sine
Operating shock	3.0 G, 11 ms, half-sine
Non-operating shock	<ul style="list-style-type: none">• Roll-off: 1-inch roll-off free fall, front to back rolling directions• Threshold: 25 mm threshold height at 0.75 m/s impact velocity

Related Information

- [“Acoustic Noise Emissions” on page 9](#)
- [“Cooling Zones and Airflow Clearance” on page 9](#)

Acoustic Noise Emissions

The declared noise emissions for the server are in accordance with ISO 9296 standards.

Description	Mode	Specification
LwAd (1 B = 10 dB)	Operating acoustic noise	7.7 B
	Idling acoustic noise	7.6 B
LpAm (bystander positions)	Operating acoustic noise	61.5 dB
	Idling acoustic noise	61.2 dB

Related Information

- *SPARC T3-2 Server Safety and Compliance Guide*
- [“Environmental Requirements” on page 8](#)
- [“Cooling Zones and Airflow Clearance” on page 9](#)

Cooling Zones and Airflow Clearance

Note – Proper airflow into and out of the server is essential for keeping the server’s internal temperatures within a safe operating range.

The server contains two pressurized cooling zones: the main cooling zone and the power supply cooling zone. In the main cooling zone, six fans, arranged in two redundant rows, cool the motherboard, memory risers, and I/O cards. In the power supply cooling zone, the rear power supply fans cool the power supplies and the front drive bays. The server must maintain a pressurized plastic dividing wall seal so that the power supply fans can draw air through the front drive bays.

The server draws cool air from the front of the server and expels hot air out the rear.

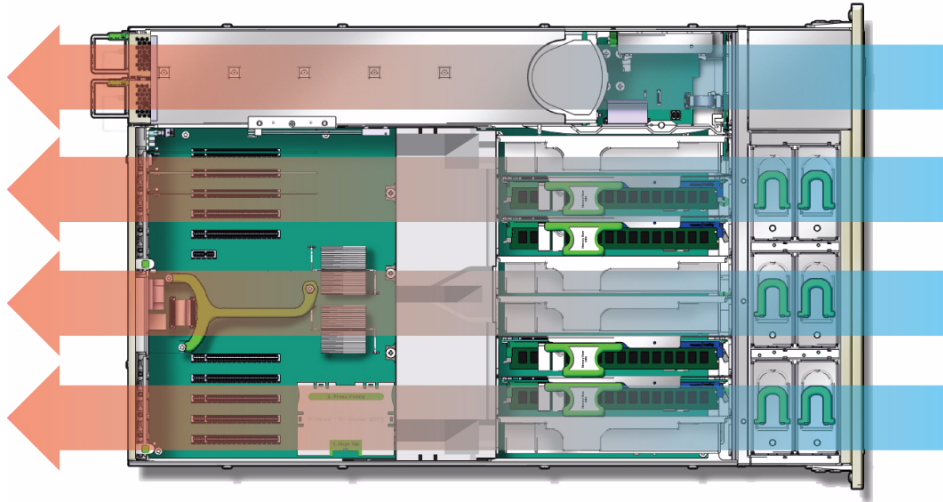

To avoid overheating the server:

- Ensure that inlet air enters at the front of the server and exits from the back.
- Ensure unobstructed airflow through the server.
- Do not direct warm air toward the front air intake of the server.
- Prevent recirculation of exhaust air within a rack or cabinet.
- Manage cables to minimize interfering with the server exhaust vent.
- Ensure that the server ventilation openings used for intake and outflow of air provide an open area that is at least 60% of the open area perforations across the front and rear of the server.
- Allow a minimum of 5 mm (0.2 in) clearance at the front of the system and 80 mm (3.1 in) at the rear of the server when mounted. These clearance values are based on the preceding inlet and exhaust impedance (available open area) and assume a uniform distribution of the open area across the inlet and exhaust areas. Clearance values greater than these are recommended for improved cooling performance.

Note – Be mindful that the combination of inlet and exhaust restrictions such as cabinet doors and the spacing of the server from the doors can affect the cooling performance of the server.

Related Information

- [“Environmental Requirements” on page 8](#)
- [“Acoustic Noise Emissions” on page 9](#)

Shipping Kit Inventory List

Note – When you receive your server, place it in the environment where you will install it. Leave it in its shipping crate at its final destination for 24 hours. This resting period prevents thermal shock and condensation.

Verify that you have received all of the components that ship with your server.

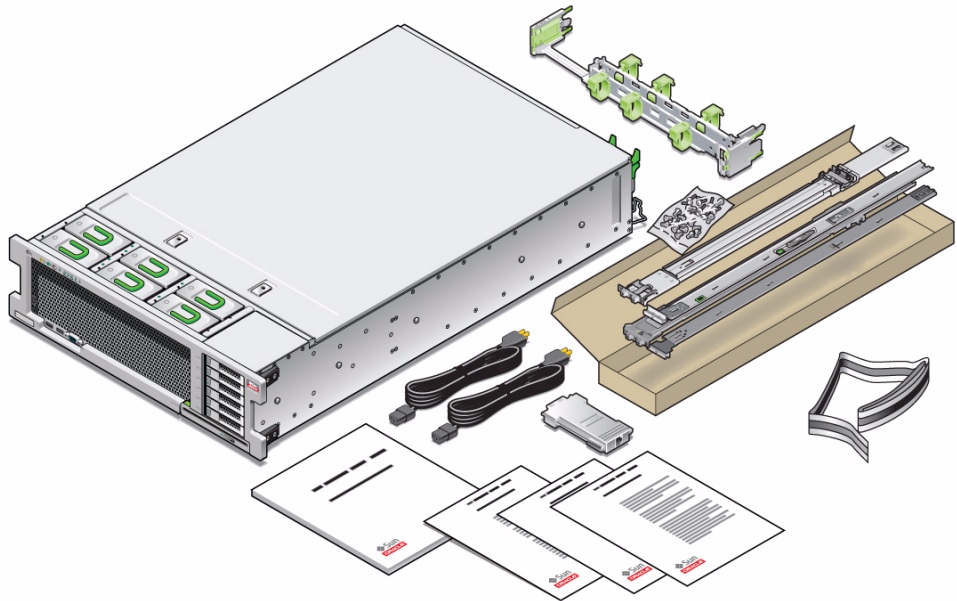

- SPARC T3-2 server
- 2 AC power cords (if ordered)
- RJ-45 to DB-9 crossover adapter for the SER MGT port
- Antistatic wrist strap
- Rackmount kit
- Cable management arm (if ordered)
- *SPARC T3-2 Server Getting Started Guide* with license and safety documents
- Optional components (for example, PCIe cards) that are packaged separately from the other items

Related Information

- “Server Overview” on page 3
- “Confirming Server Specifications” on page 5

Front Panel Components

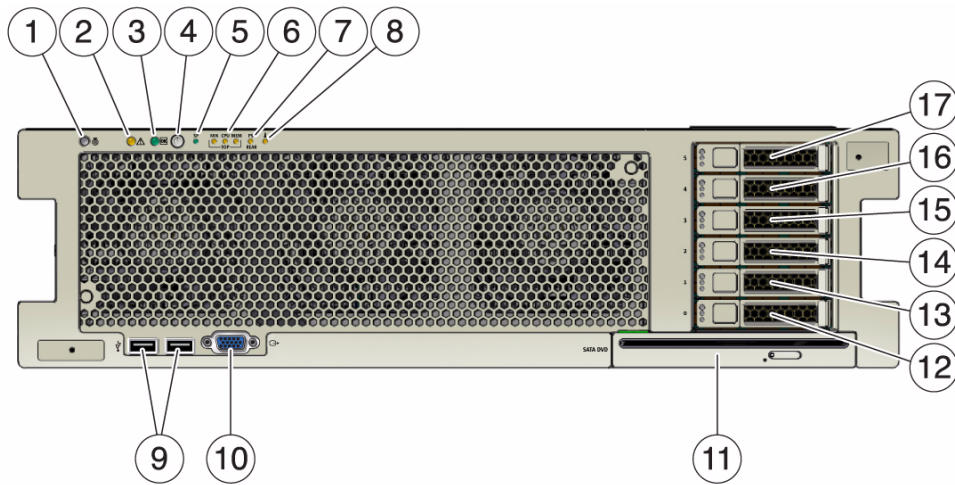

No.	Description	No.	Description
1	Locator LED/Locator button: white	10	DB-15 video connector
2	Service Action Required LED: amber	11	SATA DVD drive (optional)
3	Main Power/OK LED: green	12	Drive 0 (optional)
4	Power button	13	Drive 1 (optional)
5	SP OK/Fault LED: green/amber	14	Drive 2 (optional)
6	Service Action Required LEDs (3) for Fan Module (FAN), Processor (CPU) and Memory: amber	15	Drive 3 (optional)
7	Power Supply (PS) Fault (Service Action Required) LED: amber	16	Drive 4 (optional)
8	Over Temperature Warning LED: amber	17	Drive 5 (optional)
9	USB 2.0 connectors (2)		

Related Information

- “Back Panel Components” on page 13
- “Power On the System for the First Time” on page 52

Back Panel Components

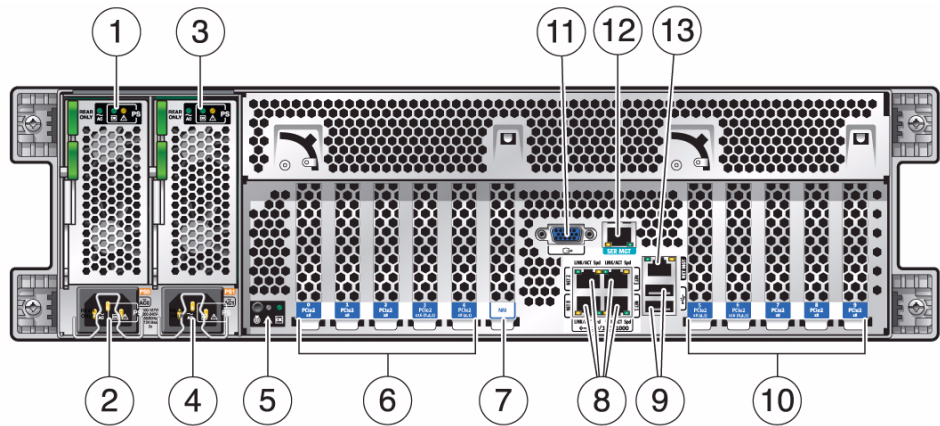

No.	Description	No.	Description
1	Power supply unit 0 status indicator LEDs: <ul style="list-style-type: none">• Service Action Required: amber• AC OK: green or amber	8	Network 10/100/1000 ports: NET0-NET3
2	Power supply unit 0 AC inlet	9	USB 2.0 connectors (2)
3	Power supply unit 1 status indicator LEDs: <ul style="list-style-type: none">• Service Action Required: amber• AC OK: green or amber	10	PCIe card slots 5-9
4	Power supply unit 1 AC inlet	11	DB-15 video connector
5	System status LEDs: <ul style="list-style-type: none">• Power/OK: green• Attention: amber• Locate: white	12	SP SER MGT RJ-45 serial port
6	PCIe2 card slots 0-4	13	SP NET MGT RJ-45 network port
7	Network module card slot		

Related Information

- “Front Panel Components” on page 12
- “Connecting the Server Cables” on page 35

Server Handling Precautions



Caution – Deploy the anti-tilt bar on the equipment rack before beginning an installation.



Caution – The server weighs approximately 80 lbs (36.29 kg). Two people are required to lift and mount this 2U server into a rack enclosure when using the procedures in this document.



Caution – When completing a two-person procedure, always communicate your intentions clearly before, during, and after each step to minimize confusion.

Related Information

- “Physical Specifications” on page 5
- “Installing the Server” on page 17
- *SPARC T3-2 Server Getting Started Guide*

ESD Precautions

Electronic equipment is susceptible to damage by static electricity. Use a grounded antistatic wrist strap, foot strap, or equivalent safety equipment to prevent ESD when you install or service the servers.



Caution – To protect electronic components from electrostatic damage, which can permanently disable the system or require repair by service technicians, place components on an antistatic surface, such as an antistatic discharge mat, an antistatic bag, or a disposable antistatic mat. Wear an antistatic grounding strap connected to a metal surface on the chassis when you work on system components.

Related Information

- [“Installing the Server” on page 17](#)
- [“Connecting the Server Cables” on page 35](#)

Tools Needed for Installation

To install the system, you must have the following tools:

- No. 2 Phillips screwdriver
- ESD mat and grounding strap

In addition, you must provide a system console device, such as one of the following:

- ASCII terminal
- Workstation
- Terminal server
- Patch panel connected to a terminal server

Related Information

- [“Optional Component Installation” on page 16](#)
- *SPARC T3-2 Server Service Manual*

Optional Component Installation

The standard components of the server are installed at the factory. However, if you ordered options such as additional memory or PCIe cards, these options will be shipped separately. If possible, install these components prior to installing the server in a rack.

If you ordered any options that are not factory-installed, see the *SPARC T3-2 Server Service Manual* and the component’s documentation for installation instructions.

Note – The list of optional components can be updated without notice. Refer to the product web pages for the most current list of components supported in the server.

Related Information

- The optional component documentation
- *SPARC T3-2 Server Service Manual*

Installing the Server

These topics describe how to install the server into a rack using the rail assembly in the rackmount kit. Perform these procedures if you purchased the rail assembly.

Note – In this guide, the term rack means either an open rack or a closed cabinet.

- [“Rack Compatibility” on page 18](#)
- [“Stabilize the Rack for Installation” on page 20](#)
- [“Disassemble Slide Rails” on page 20](#)
- [“Install Mounting Brackets” on page 22](#)
- [“Attach Slide Rail Assemblies” on page 23](#)
- [“Install Server Into the Slide Rail Assemblies” on page 26](#)
- [“Install the CMA” on page 28](#)
- [“Verify Operation of Slide Rails and CMA” on page 33](#)

Related Information

- [“Preparing for the Installation” on page 1](#)
- [“Connecting the Server Cables” on page 35](#)

Rack Compatibility

Check that your rack is compatible with the slide rail and cable management arm options. The optional slide rails are compatible with a wide range of equipment racks that meet the following standards.

Item	Requirement
Structure	Four-post rack (mounting at both front and rear). Two-post racks are not compatible.
Rack horizontal opening and unit vertical pitch	Conforms to ANSI/EIA 310-D-1992 or IEC 60927 standards.
Rack rail mounting hole sizes	Only 9.5 mm square hole and M6 round mounting holes are supported. All other sizes, including 7.2 mm, M5, or 10-32 mounting holes, are <i>not</i> supported.
Distance between front and rear mounting planes	Minimum 622 mm and maximum 895 mm (24.5 inches to 35.25 inches).
Clearance depth in front of front mounting plane	Distance to front cabinet door is at least 27 mm (1.06 inch).
Clearance depth behind front mounting plane	Distance to rear cabinet door is at least 900 mm (35.5 inches) with the cable management arm, or 770 mm (30.4 inches) without the cable management arm.
Clearance width between front and rear mounting planes	Distance between structural supports and cable troughs is at least 456 mm (18 inches).
Server dimensions	Depth (not including PSU handle): 732 mm (28.82 inches) Width (not including ears): 436.5 mm (17.19 inches) Height: 129.85 mm (5.11 inches)



Caution – Equipment Loading: Always load equipment into a rack from the bottom up so that the rack will not become top-heavy and tip over. Deploy your rack's anti-tip bar to prevent the rack from tipping during equipment installation.



Caution – Elevated Operating Ambient Temperature: If the server is installed in a closed or multi-unit rack assembly, the operating ambient temperature of the rack environment might be greater than room ambient temperature. Therefore, install the equipment only in an environment compatible with the maximum ambient temperature (T_{ma}) specified for the server.



Caution – Reduced Air Flow: Install the equipment in a rack so that the amount of air flow is adequate for the safe operation of the equipment.



Caution – Mechanical Loading: Mount the equipment in the rack so that the weight is distributed evenly. A hazardous condition can exist with uneven mechanical loading.



Caution – Circuit Overloading: Do not overload the power supply circuits. Before connecting the server to the supply circuit, review the equipment nameplate power ratings and consider the effect that circuit overloading might have on overcurrent protection and supply wiring.



Caution – Reliable Earthing: Maintain reliable earthing of rackmounted equipment. Give particular attention to supply connections other than direct connections to the branch circuit (for example, use of power strips).



Caution – Do not use slide rail mounted equipment as a shelf or a work space.

Related Information

- “Physical Specifications” on page 5
- “Server Handling Precautions” on page 14
- “Stabilize the Rack for Installation” on page 20

▼ Stabilize the Rack for Installation



Caution – To reduce the risk of personal injury, stabilize the expansion rack cabinet and extend all anti-tilt devices before installing the server.

Refer to your rack documentation for detailed instructions for the following steps.

1. **Open and remove the front and rear doors from the rack cabinet.**
2. **To prevent the rack cabinet from tipping during the installation, stabilize the cabinet using all anti-tilt mechanisms provided.**
3. **If there are leveling feet beneath the rack cabinet to prevent it from rolling, extend these leveling feet fully downward to the floor.**
4. **Fully extend the rack cabinet's anti-tilt legs or anti-tilt bar, which are located at the bottom front of the rack cabinet.**

Related Information

- The rack documentation
- *SPARC T3-2 Server Safety and Compliance Guide*
- [“Rack Compatibility” on page 18](#)

▼ Disassemble Slide Rails

Complete the following task to disassemble the slide rails before installation.

To remove the mounting brackets from the slide rail assemblies:

1. **Unpack the slide rails.**
2. **Locate the slide rail lock at the front of one of the slide rail assemblies.**

FIGURE: Disassembling the Slide Rail Before Installation

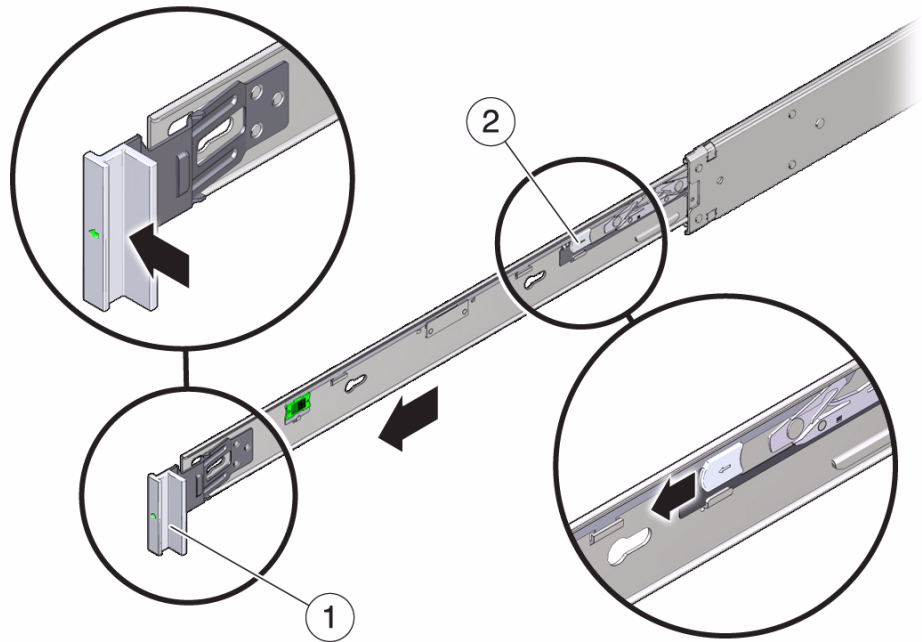

Figure Legend

-
- | | |
|---|---------------------------------|
| 1 | Slide rail lock |
| 2 | Mounting bracket release button |
-

3. Press and hold the slide rail lock toward the direction of the arrow while you pull the mounting bracket out of the slide rail assembly until it reaches the stop.
4. Push the mounting bracket release button toward the front of the mounting bracket, and simultaneously withdraw the mounting bracket from the slide rail assembly.
5. Repeat for the remaining slide rail assembly.

Related Information

- [“Install Mounting Brackets” on page 22](#)
- [“Attach Slide Rail Assemblies” on page 23](#)
- [“Install Server Into the Slide Rail Assemblies” on page 26](#)

▼ Install Mounting Brackets

You must install the mounting brackets onto the server before you can rackmount the server.

1. Position a mounting bracket against the chassis so that the slide rail lock is at the server front, and the five keyhole openings on the mounting bracket are aligned with the five locating pins on the side of the chassis.

Note – The mounting brackets are identical and can be installed on either side of the chassis.

FIGURE: Aligning the Mounting Bracket With the Server Chassis

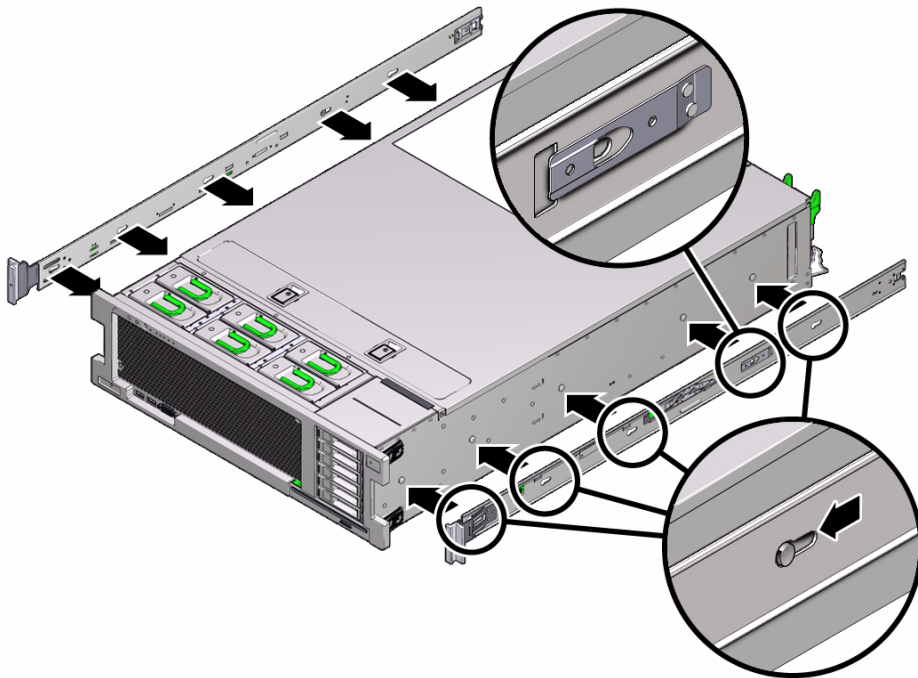

2. With the heads of the five chassis locating pins protruding through the five keyhole openings in the mounting bracket, pull the mounting bracket toward the front of the chassis until the mounting bracket clip locks into place with an audible click.

3. Verify that the rear locating pin has engaged the mounting bracket clip.
4. Repeat to install the remaining mounting bracket on the other side of the server.

Related Information

- [“Disassemble Slide Rails” on page 20](#)
- [“Attach Slide Rail Assemblies” on page 23](#)
- [“Install Server Into the Slide Rail Assemblies” on page 26](#)

▼ Attach Slide Rail Assemblies

Complete the following procedures to attach the slide rail assemblies to the rack.

Note – The slide rail assemblies support only racks with 9.5-mm square holes and M6 round holes. All other racks, including those racks with 7.2-mm, M5, or 10-32 mounting holes, are *not* supported. Refer to your rack documentation for information about the size of its rail holes.

1. **(Optional) If you must move the rack with the server installed, secure the slide rail assemblies to the rack with mounting screws and cage nuts.**

Insert the cage nuts prior to performing the next steps. Refer to the *Rail Rackmount Kit Overview and Information* card for instructions on inserting these cage nuts. This card is included with the rack kit.

2. **Position a slide rail assembly in your rack so that the slide rail assembly front bracket is on the outside of the front rack post and the slide rail assembly rear bracket is on the inside of the rear rack post.**

3. **Align the slide rail assembly mounting pins with the front and rear rack post mounting holes. Then lock the assembly into place by pushing the assembly toward the rear of the rack until the mounting pins engage the rack.**

You will hear an audible click when the mounting pins engage the rack.

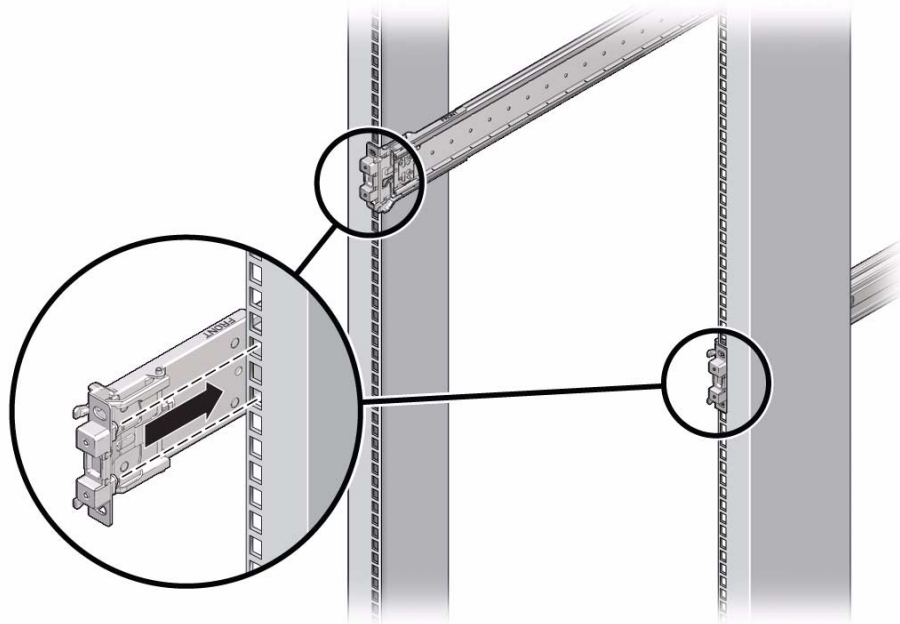

The slide assembly mounting pins accommodate either 9.5 mm square mounting holes or M6 round mounting holes. No other mounting hole sizes are supported.

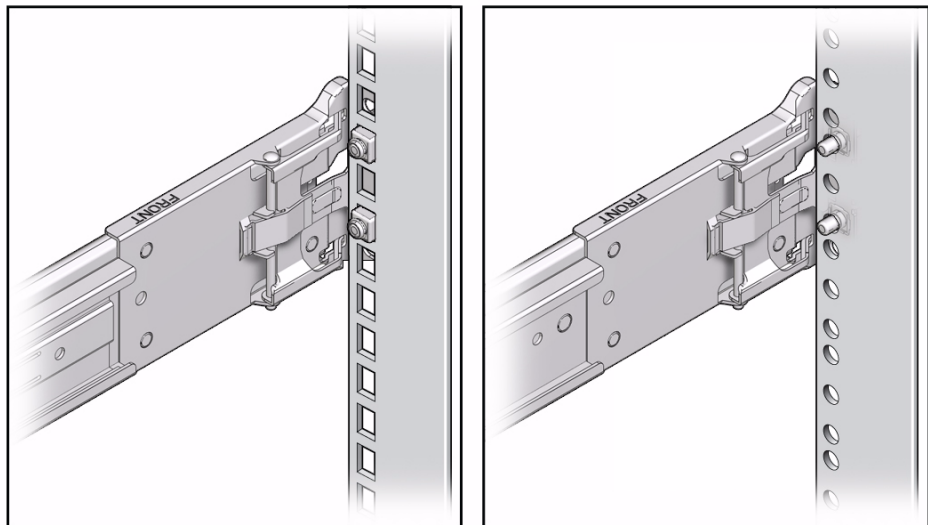

4. (Optional) If you chose to secure the slide rail assembly to the rack with screws, insert the M6 mounting screws through both front and rear slide rail brackets and rack posts, and then secure the screws to the rack posts with the caged nuts.

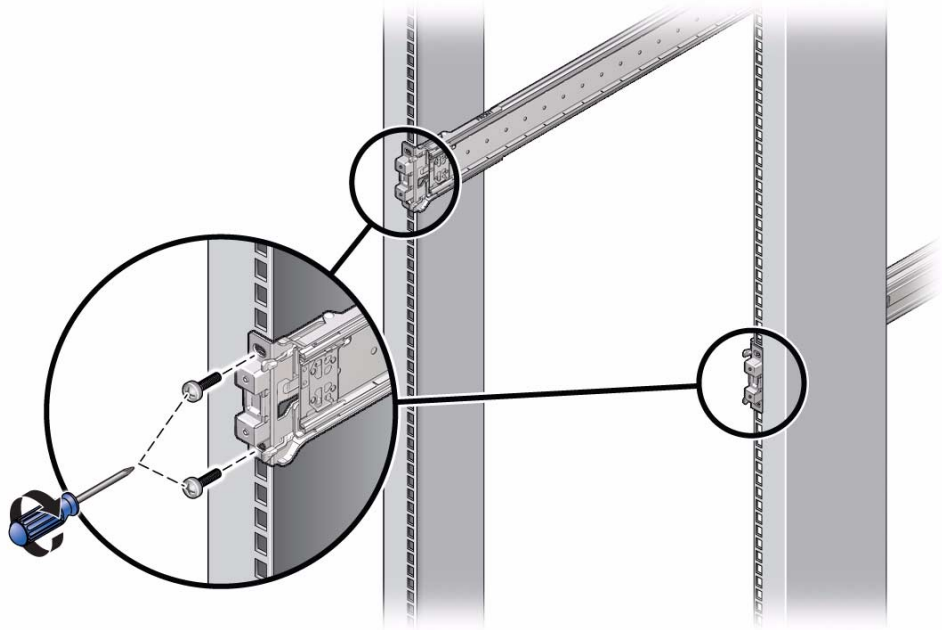

5. Repeat [Step 2](#) through [Step 4](#) for the remaining slide rail assembly.



Caution – If your rack does not have an anti-tip device, the rack could tip over when installing the server.

6. If available, extend the anti-tip legs or anti-tip bar at the bottom of the rack.

Refer to your rack documentation for instructions. For more information, see [“Stabilize the Rack for Installation”](#) on page 20.

Related Information

- [“Disassemble Slide Rails”](#) on page 20
- [“Install Mounting Brackets”](#) on page 22
- [“Install Server Into the Slide Rail Assemblies”](#) on page 26

▼ Install Server Into the Slide Rail Assemblies

Use this procedure to install the server chassis, with mounting brackets, into the slide rail assemblies that are mounted to the rack.



Caution – This procedure requires a minimum of two people because of the weight of the server. Attempting this procedure alone could result in equipment damage or personal injury.



Caution – Always load equipment into a rack from the bottom up so that the rack will not become top-heavy and tip over. Extend your rack's anti-tip bar or anti-tilt legs to prevent the rack from tipping during equipment installation. See [“Stabilize the Rack for Installation”](#) on page 20 for more information.

1. Push the slide rails into the slide rail assemblies in the rack as far as possible.
2. Raise the server so that the rear ends of the mounting brackets are aligned with the slide rail assemblies that are mounted in the rack.

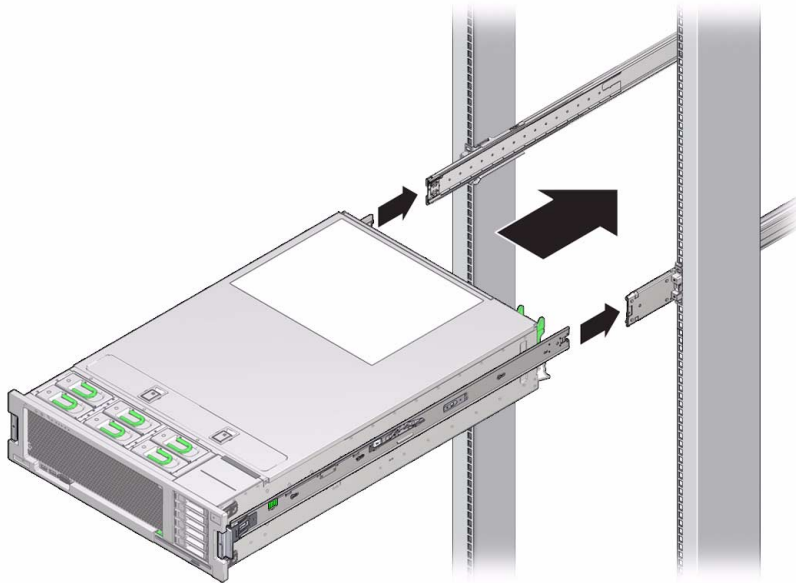

3. Insert the mounting brackets into the slide rails and then push the server into the rack until the mounting brackets encounter the slide rail stops (approximately 12 inches, or 30 cm).



Caution – When inserting the server into the slide rail, ensure that both the top and bottom mounting lips of the mounting brackets are inserted into the slide rail. The server should slide forward and backward easily if correctly installed. If the unit does not slide easily, ensure that each mounting lip is inserted properly. If the mounting brackets are not inserted properly, the unit might fall when it is removed from the rack.

4. Simultaneously push and hold the green slide rail release buttons on each mounting bracket while you push the server into the rack.

Continue pushing until the slide rail locks (on the front of the mounting brackets) engage the slide rail assemblies. You will hear an audible click.

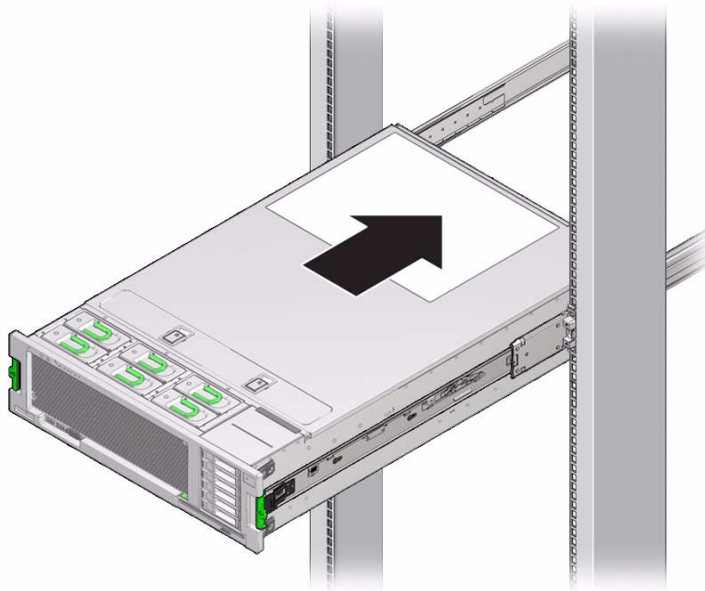

Caution – Verify that the server is securely mounted in the rack and that the slide rail locks are engaged with the mounting brackets before continuing.

Related Information

- “Disassemble Slide Rails” on page 20
- “Install Mounting Brackets” on page 22
- “Attach Slide Rail Assemblies” on page 23
- “Install the CMA” on page 28
- “Verify Operation of Slide Rails and CMA” on page 33

▼ Install the CMA

The cable management arm is an optional assembly that you can use to route the server cables in the rack.

1. **Unpack the CMA parts.**
2. **Take the CMA to the back of the equipment rack and ensure that you have adequate room to work around the back of the server.**

Note – References to “left” or “right” in this procedure assume that you are facing the back of the equipment rack.

3. **Remove tape to separate the parts of the CMA.**

4. Insert the CMA mounting bracket connector into the right slide rail until the connector locks into place with an audible click.

FIGURE: Inserting the CMA Mounting Bracket Into the Back of the Right Slide Rail

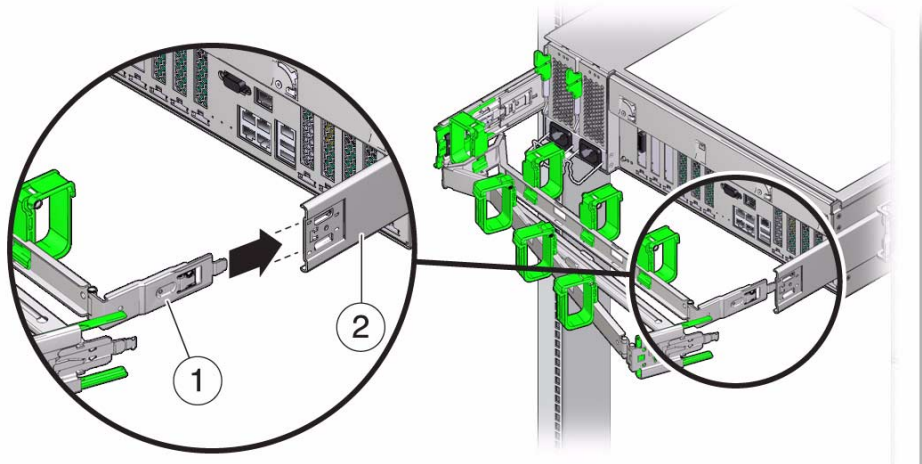

Figure Legend

-
- | | |
|---|----------------------|
| 1 | CMA mounting bracket |
| 2 | Right slide rail |
-

5. Insert the right CMA slide rail connector into the right slide rail assembly until the connector locks into place with an audible click.

FIGURE: Inserting CMA Slide Rail Connector Into the Back of the Right Slide Rail

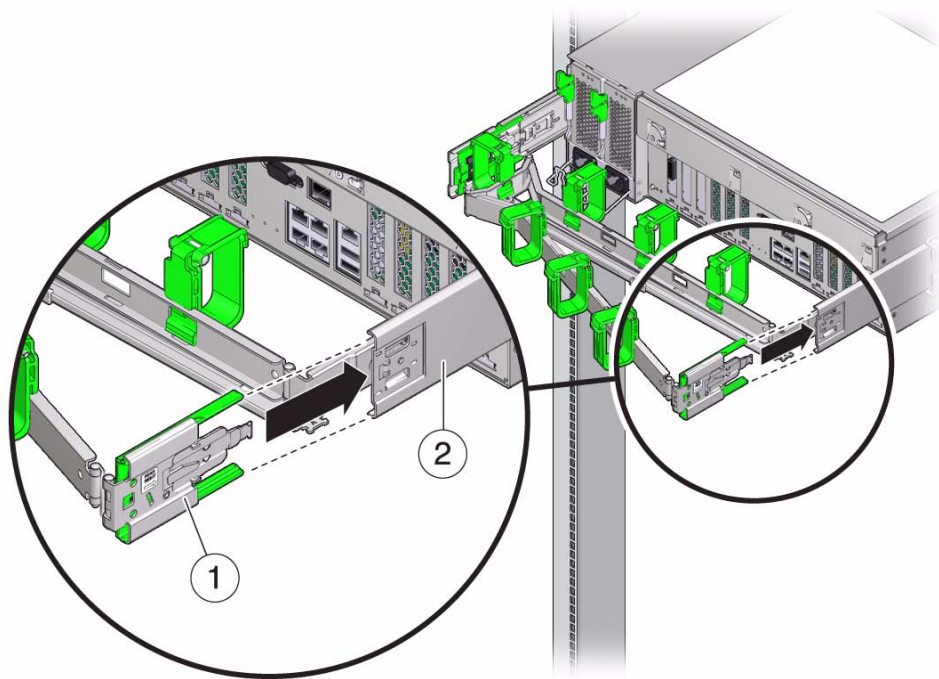

Figure Legend

-
- 1 CMA slide rail connector
 - 2 Right slide rail
-

6. Insert the left CMA slide rail connector into the left slide rail assembly until the connector locks into place with an audible click.

FIGURE: Inserting the CMA Slide Rail Connector Into the Back of the Left Slide Rail

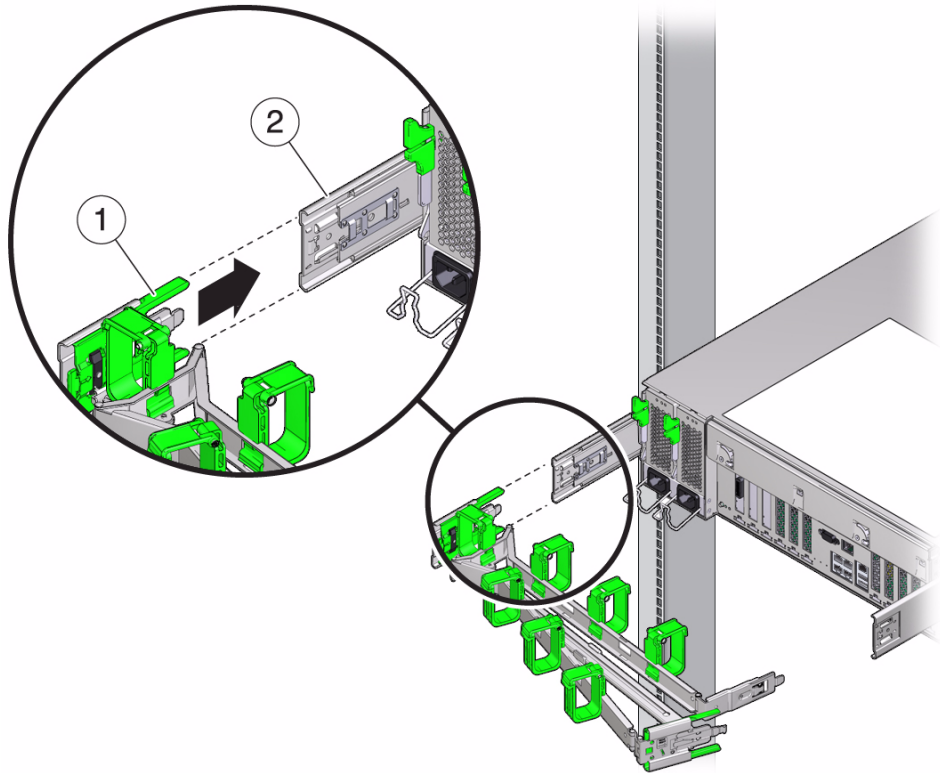

Figure Legend

-
- | | |
|---|--------------------------|
| 1 | CMA slide rail connector |
| 2 | Left slide rail |
-

7. Install and route cables to your server, as required.

Note – Instructions for installing the server cables are provided in [“Connecting the Server Cables”](#) on page 35.

8. If required, attach the cable hooks and loop straps to the CMA, and press the hooks and straps into place to secure the cables.

Note – Cable hooks and loop straps are preinstalled on the CMA. Perform the procedure in this step if you need to reinstall cable hooks and straps on the CMA.

For best results, place three cable straps, evenly spaced, on the rear-facing side of the CMA and three cable straps on the side of the CMA nearest the server.

FIGURE: Installing CMA Cable Straps

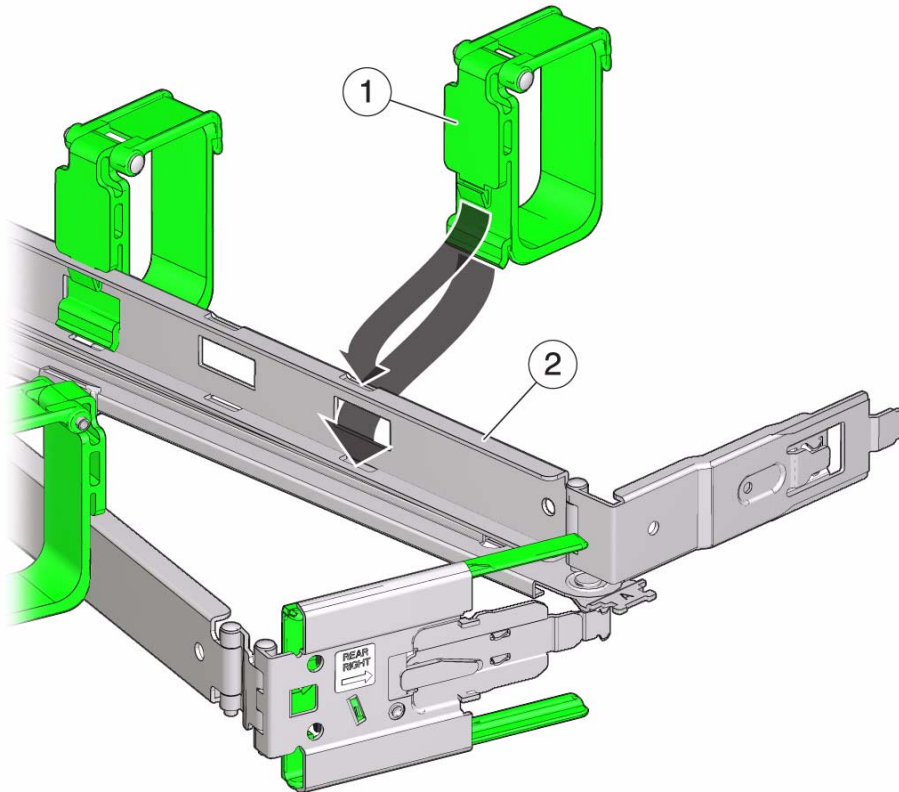

Figure Legend

-
- | | |
|---|-----------------|
| 1 | CMA cable strap |
| 2 | CMA arm |
-

Related Information

- [“Verify Operation of Slide Rails and CMA”](#) on page 33
- [“Secure Cables to CMA”](#) on page 47

▼ Verify Operation of Slide Rails and CMA

Use the following procedure to ensure that the slide rails and CMA are operating correctly.

Note – Two people are recommended for this procedure: one to move the server in and out of the rack, and one to observe the cables and CMA.

1. Slowly pull the server out of the rack until the slide rails reach their stops.
2. Inspect the attached cables for any binding or kinks.
3. Verify that the CMA extends fully from the slide rails.

4. Push the server back into the rack, as follows:

When the server is fully extended, you must release two sets of slide rail stops to return the server to the rack:

- a. The first set of stops are levers, located on the inside of each slide rail, just behind the back panel of the server. Push in both green levers simultaneously and slide the server toward the rack.

The server will slide in approximately 18 inches (46 cm) and stop.

Verify that the cables and the CMA retract without binding before you continue.

- b. The second set of stops are the slide rail release buttons, located near the front of each mounting bracket. Simultaneously push both of the green slide rail release buttons, and push the server completely into the rack until both slide rail locks engage.

5. Adjust the cable straps and CMA, as required.

Related Information

- [“Install the CMA” on page 28](#)
- [“Secure Cables to CMA” on page 47](#)

Connecting the Server Cables

Connect and configure the network and serial ports before you attempt to boot the server.

- “Cabling Requirements” on page 36
- “Rear Panel Connectors and Ports” on page 37
- “Connect the SER MGT Cable” on page 39
- “Connect the NET MGT Cable” on page 40
- “Connect the Ethernet Network Cables” on page 41
- “Connect the Network Module Cables” on page 42
- “Connect Other Data Cables” on page 46
- “Prepare the Power Cords” on page 46
- “Secure Cables to CMA” on page 47

Related Information

- “Verify Operation of Slide Rails and CMA” on page 33
- “Back Panel Components” on page 13

Cabling Requirements

Prior to cabling and powering-on the server, gather the following network information:

- Netmask
- IP address for the service processor
- Gateway IP address

At a minimum, you must connect cables to these ports before powering-on the server for the first time:

- SP SER MGT port
- SP NET MGT port
- At least one system on-board Ethernet network port
- Power cables to the power supply inlet ports

Related Information

- [“Connect the SER MGT Cable” on page 39](#)
- [“Connect the NET MGT Cable” on page 40](#)
- [“Connect the Ethernet Network Cables” on page 41](#)
- [“Prepare the Power Cords” on page 46](#)
- [“Power On the System for the First Time” on page 52](#)

Rear Panel Connectors and Ports

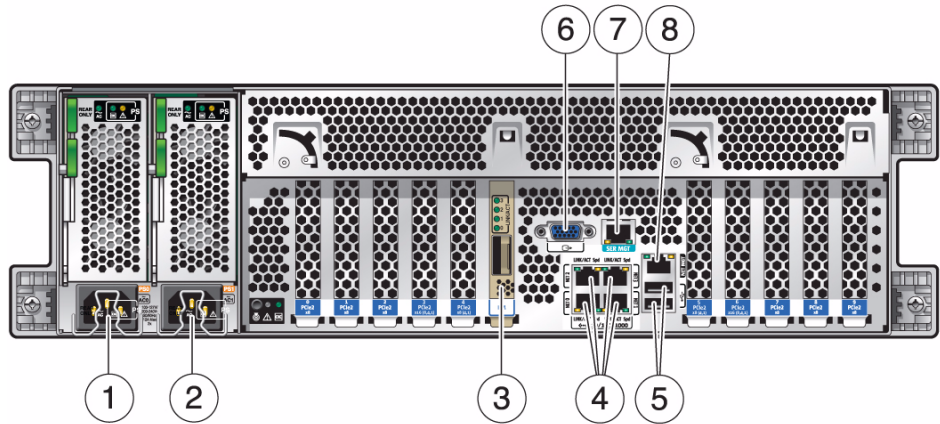

No.	Cable Port or Expansion Slot	Description
1	Power supply 0 AC inlet	Use the supplied or supported AC power cords.
2	Power supply 1 AC inlet	Note - Do not attach power cords to the power supplies until you have finished connecting the data cables and have connected the server to a serial terminal or a terminal emulator (PC or workstation).
3	SPARC T3-2 Server 10 Gb Network Module QSFD port	The SPARC T3-2 Server 10 Gb Network Module card's QSFD port provides four 10 Gb connections when using a supported transceiver and cable.
4	Network 10/100/1000 ports (NET0, NET1, NET2, and NET3)	The four Gigabit Ethernet ports enable you to connect the system to the network. Note - Using the ILOM sideband management feature, you can access the SP using one of these ports. Refer to the <i>SPARC T3 Series Servers Administration Guide</i> for instructions.
5	USB ports (USB 0, USB 1)	The two USB ports support hot-plugging. You can connect and disconnect USB cables and peripheral devices while the server is running, without affecting system operations. Note - You can connect up to 126 devices to each of the four USB controllers (two ports in front, two ports in back), for a total of 504 USB devices per server.

No.	Cable Port or Expansion Slot	Description
6	DB-15 video port	Use a DB-15 video cable to connect to a video device.
7	SP NET MGT Ethernet port	<p>The network management port is the optional connection to the ILOM SP. The service processor network management port uses an RJ-45 cable for a 10/100BASE-T connection. If your network does not use DHCP, this port will not be available until you have configured network settings through the SP SER MGT port.</p> <p>Note - This port does not support connections to Gigabit networks.</p>
8	SP SER MGT port	<p>The serial management port uses an RJ-45 cable and is always available. This port is the default connection to the ILOM system controller.</p>

Related Information

- [“Cabling Requirements” on page 36](#)
- [“Secure Cables to CMA” on page 47](#)

▼ Connect the SER MGT Cable

The service processor serial management port is labeled SER MGT. Use the SP SER MGT port *only* for server management. This port is the default connection between the service processor and a terminal or a computer. Use this port for server management.



Caution – Do not attach a modem to this port.

- **Connect a Category 5 (or better) cable from the SER MGT to a terminal device.**
When connecting a DB-9 cable, use an adapter to perform the crossovers given for each connector.

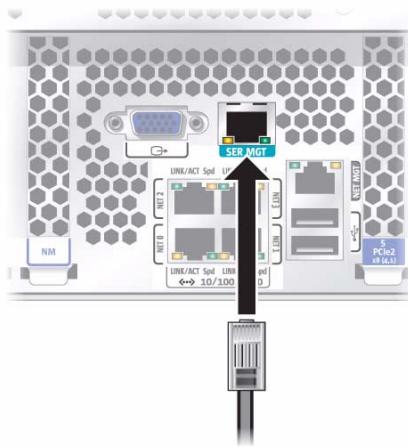

Related Information

- “Connect the NET MGT Cable” on page 40
- “Connect a Terminal or Emulator to the SER MGT Port” on page 51
- “SER MGT Port” on page 63

▼ Connect the NET MGT Cable

The service processor network management port is labeled NET MGT. After the initial server configuration, you can connect to the service processor over an Ethernet network using this NET MGT port.

If your network uses a DHCP server to assign IP addresses, the DHCP server will assign an IP address to this NET MGT port. With this IP address, you can connect to the service processor using an SSH connection. If your network does not use DHCP, this NET MGT port will not be accessible until you configure the network settings through the SER MGT port. For instructions, see [“Assign a Static IP Address to the SP”](#) on page 57.

- **Connect a Category 5 (or better) cable from the NET MGT port to your network switch or hub.**

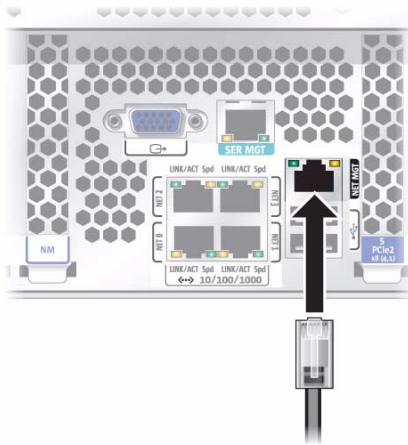

Related Information

- [“Connect the Ethernet Network Cables”](#) on page 41
- [“Assign a Static IP Address to the SP”](#) on page 57
- [“NET MGT Port”](#) on page 64

▼ Connect the Ethernet Network Cables

The server has four Gigabit Ethernet network connectors, marked NET0, NET1, NET2, and NET3. Use these ports to connect the server to the network.

Note – The ILOM sideband management feature enables you to access the SP using one of these Ethernet ports. Refer to the *SPARC T3 Series Servers Administration Guide* for instructions.

1. Connect a Category 5 (or better) cable from your network switch or hub to Ethernet Port 0 (NET0) on the rear of the chassis.

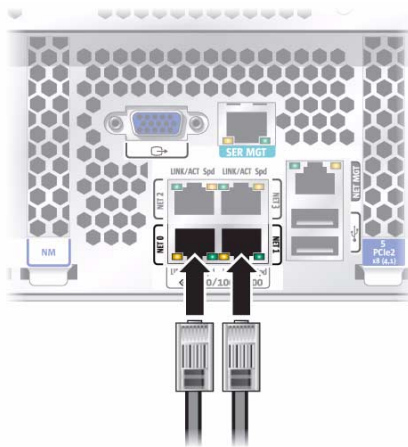

2. Connect Category 5 (or better) cables from your network switch or hub to the remaining Ethernet ports (NET1, NET2, NET3), as needed.

Related Information

- *SPARC T3 Series Server Administration Guide*
- “Powering On the Server for the First Time” on page 49
- “Gigabit Ethernet Ports” on page 65

▼ Connect the Network Module Cables

The optional SPARC T3-2 Server 10 Gb Network Module card provides four 10 GbE network connections when using a supported QSFP transceiver module.

1. Remove the transceiver module from its packaging and place it on an antistatic mat.
2. Remove the protective end cap from the transceiver module.
3. Open the locking handle on the transceiver module until you feel the handle click into position.

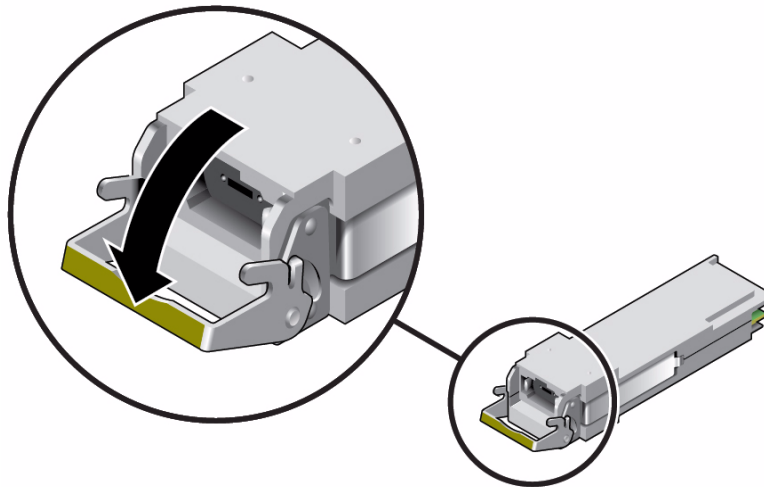

4. Align the transceiver module to the QSFP slot as shown in the following figure.

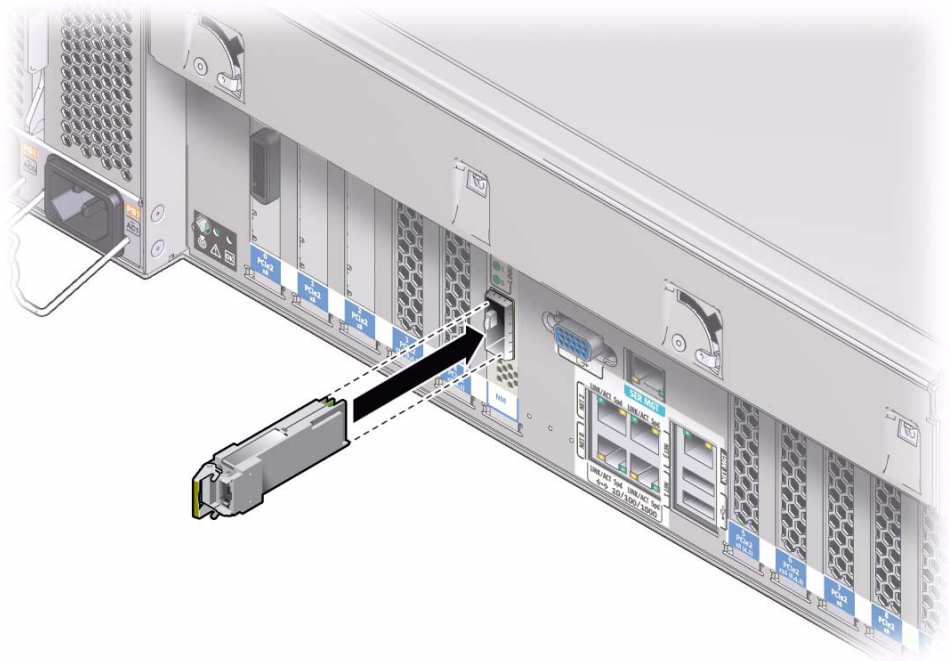

5. Holding the transceiver module by its edges, carefully slide the module into the QSFP slot.
6. Applying even pressure to the top and bottom of the transceiver module, push the module until it is firmly seated in the slot.

7. Push the handle closed to lock the transceiver module in place.

Note – If you open the locking handle when the transceiver module is installed, remove the transceiver module completely and reinstall it. The handle operates an internal lock. Opening the handle can disconnect the transceiver module, even though it might appear to be connected.

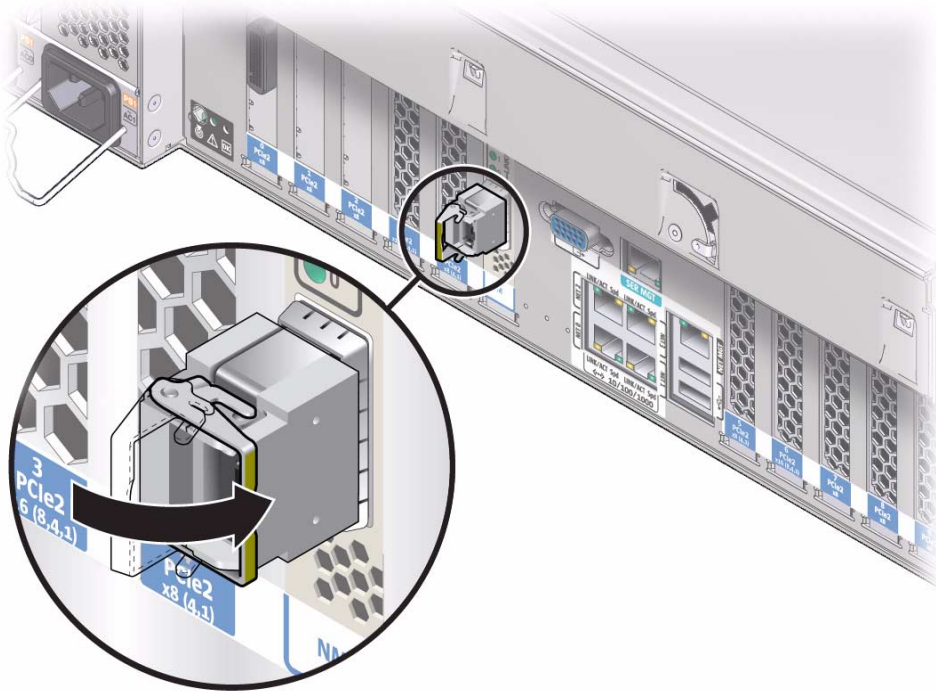

8. Plug the cable into the connector.

Verify that the handle is in the locked position, and then connect the cable to the transceiver module.

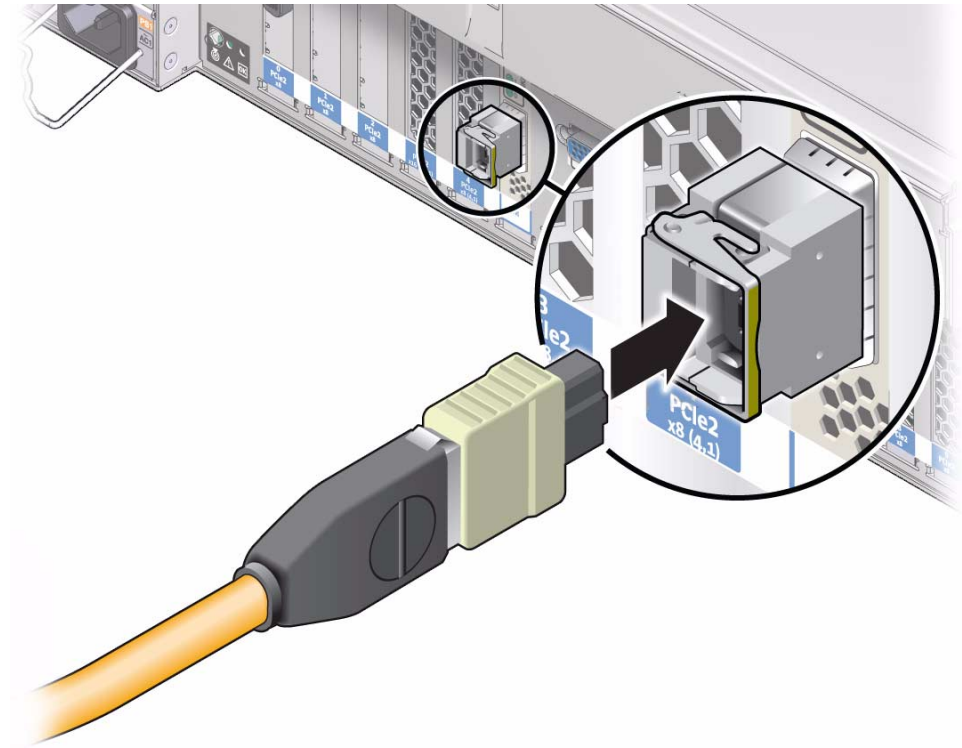

Related Information

- The network equipment documentation
- [“QSFP Port” on page 69](#)

▼ Connect Other Data Cables

If your server configuration includes optional PCIe cards, connect the appropriate I/O cables to their connectors.

- **If your server configuration includes optional PCIe cards, connect the appropriate I/O cables to their connectors.**

Refer to the PCIe card documentation for specific instructions.

Related Information

- The PCIe card documentation
- *SPARC T3-2 Server Service Manual*

▼ Prepare the Power Cords

Prepare the power cords by routing them from the AC power source to the server.



Caution – Do not attach power cables to the power supplies until you have connected the server to a serial terminal or a terminal emulator (PC or workstation).

Note – The server goes into Standby mode and the ILOM service processor initializes as soon as a power cable connects a power supply to an external power source. System messages might be lost after 60 seconds if a terminal or terminal emulator is not connected to the SER MGT port before power is applied.

Note – ILOM will signal a fault if both power supplies are not cabled at the same time, since it will be a nonredundant condition.

1. **Ensure that the circuit breakers are off on the AC power source.**

Refer to the AC power source documentation for instructions.

2. **Route the power cords from the AC power source to the rear of the server.**

Do not attach the power cords to the power supplies at this time.

Related Information

- “Rear Panel Connectors and Ports” on page 37
- “Powering On the Server for the First Time” on page 49

▼ Secure Cables to CMA

After connecting the server cables, secure them to the cable management arm.

1. Open the cable hooks and loop straps on the CMA.

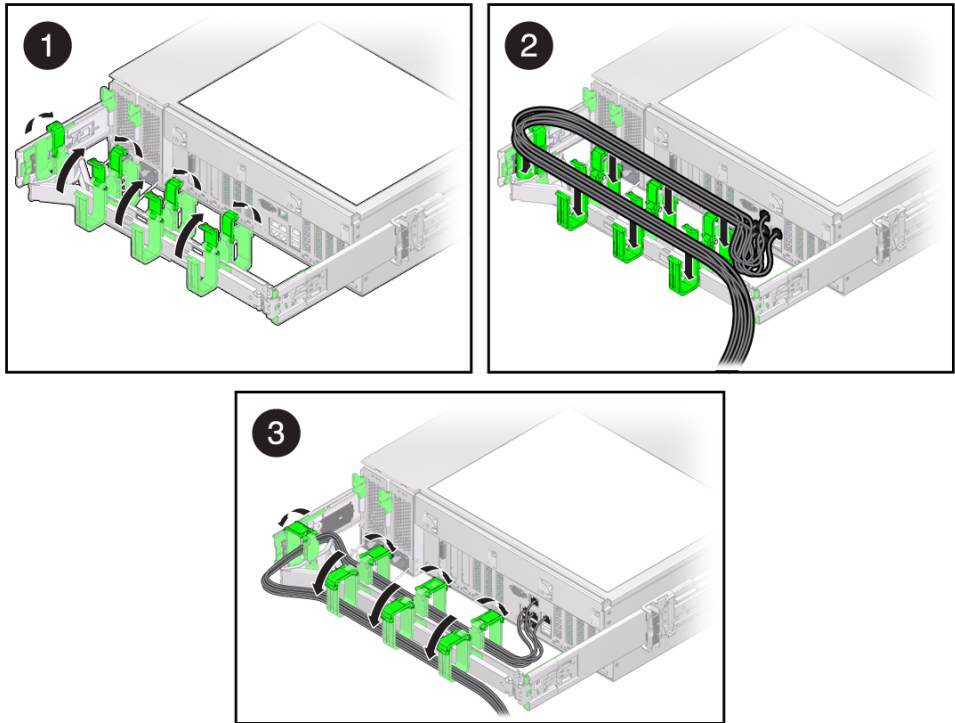

2. Route the server cables through the CMA cable hooks and straps.
3. Secure the cables to the CMA by closing the hooks and tightening the straps.
4. Verify the operation of the slide rails and CMA.
See “Verify Operation of Slide Rails and CMA” on page 33.

Related Information

- [“Install the CMA” on page 28](#)
- [“Verify Operation of Slide Rails and CMA” on page 33](#)
- [“Rear Panel Connectors and Ports” on page 37](#)

Powering On the Server for the First Time

These topics include instructions for powering on the server for the first time and configuring the Oracle Solaris OS.

This chapter contains the following topics:

- [“Power On Tasks” on page 50](#)
- [“ILOM System Console” on page 50](#)
- [“Connect a Terminal or Emulator to the SER MGT Port” on page 51](#)
- [“Power On the System for the First Time” on page 52](#)
- [“Oracle Solaris OS Configuration Parameters” on page 55](#)
- [“Assign a Static IP Address to the SP” on page 57](#)

Related Information

- [“Preparing for the Installation” on page 1](#)
- [“Installing the Server” on page 17](#)
- [“Connecting the Server Cables” on page 35](#)

Power On Tasks

When you power on the server for the first time, you must take the following steps that are not required in subsequent power-on sessions.

No.	Step	Purpose	Links
1	Connect a terminal or terminal emulator to the SER MGT port.	Enables logging into the service processor before it has been configured for network access.	“Connect a Terminal or Emulator to the SER MGT Port” on page 51
2	Log in to the service processor and change the default root password.	Change the default root password to protect the system from unauthorized access.	“Power On the System for the First Time” on page 52
3	Start the ILOM system console.	Enables you to monitor the ILOM firmware system initialization messages.	“Power On the System for the First Time” on page 52
4	Configure the Oracle Solaris OS.	After powering on the server, you will be prompted to configure the preinstalled Oracle Solaris OS.	“Power On the System for the First Time” on page 52 “Oracle Solaris OS Configuration Parameters” on page 55

Related Information

- [“Connecting the Server Cables” on page 35](#)

ILOM System Console

When you power on the system, the boot process begins under the control of the ILOM system console. The system console displays status and error messages generated by firmware-based tests that are run during system startup.

Note – To see these status and error messages, connect a terminal or terminal emulator to the SER MGT before applying power to the server.

After the system console finishes its low-level system diagnostics, the service processor initializes and runs a suite of higher level diagnostics. When you access the service processor using a device connected to the serial management port, you see the output of the ILOM diagnostics.

By default, the service processor configures the network management port automatically, retrieving network configuration settings using DHCP and allowing connections using SSH.

For a more detailed discussion on configuring the system console and connecting terminals, refer to the *SPARC T3 Series Servers Administration Guide*.

Related Information

- *SPARC T3 Series Servers Administration Guide*
- ILOM documentation
- [“Power On the System for the First Time” on page 52](#)
- [“Assign a Static IP Address to the SP” on page 57](#)

▼ Connect a Terminal or Emulator to the SER MGT Port

Prior to powering on the server for the first time, make a serial connection to the service processor. After making this serial connection, you will be able to view the system messages when you connect the power cords.

1. **Confirm that you have completed all of the preparations for installation.**
See the instructions in [“Preparing for the Installation” on page 1](#).
2. **Confirm that you have completed the installation of the server in a rack.**
See the instructions in [“Connecting the Server Cables” on page 35](#).

3. Connect a terminal or a terminal emulator (PC or workstation) to the service processor serial management port.

Configure the terminal or terminal emulator with these settings:

- 9600 baud
- 8 bits
- No parity
- 1 stop bit
- No handshake

A null modem configuration is needed, meaning the transmit and receive signals are reversed (crossed over) for DTE to DTE communications. You can use the supplied RJ-45 crossover adapters with a standard RJ-45 cable to achieve the null modem configuration.

Note – When you power on the server for the first time and you do not have a terminal or terminal emulator (PC or workstation) connected to the SP SER MGT port, you will not see system messages.

4. Continue with the installation by powering on the server for the first time.

See [“Power On the System for the First Time”](#) on page 52.

Related Information

- [“Connect the SER MGT Cable”](#) on page 39
- [“Power On the System for the First Time”](#) on page 52

▼ Power On the System for the First Time

1. Confirm that you have installed the server in a rack and attached all of the data cables.

For instructions, see:

- [“Installing the Server”](#) on page 17
- [“Connecting the Server Cables”](#) on page 35

2. Confirm that you made a serial connection to the service processor.

For instructions, see [“Connect a Terminal or Emulator to the SER MGT Port”](#) on page 51.

Note – When you power on the server for the first time and you do not have a terminal or terminal emulator (PC or workstation) connected to the SP SER MGT port, you will not see system messages.

3. **(Optional) Connect an Ethernet cable between the server’s NET MGT port and the network to which future connections to the SP and host will be made.**

Note – After the initial configuration of the system using the SP SER MGT port, communication with the SP and host is usually performed through this Ethernet interface.

4. **Connect an Ethernet cable between one of the server’s Gigabit Ethernet ports and the network to which the server will communicate.**

For instructions, see [“Connect the Ethernet Network Cables”](#) on page 41.

5. **Plug the power cords into the power supplies and into separate power sources.**

To provide redundancy, plug both power supplies into separate power sources. The system can operate with only one power connection, but there will be no redundancy.

The service processor runs on 3.3V standby voltage. As soon as AC power is connected to the system, the front panel SP OK/Fault LED flashes as the service processor powers on, runs diagnostics, and initializes the ILOM firmware.

FIGURE: Front Panel Main Power and SP LEDs

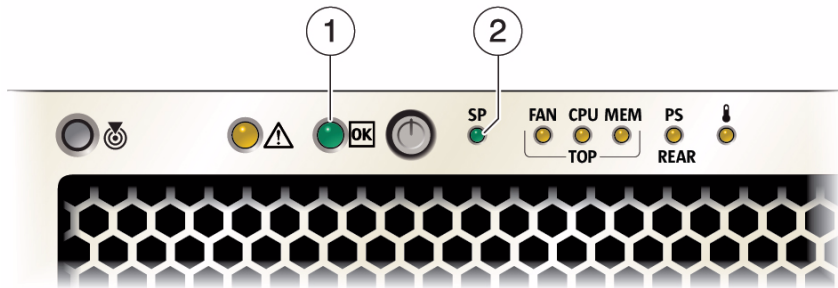

Figure Legend

-
- | | |
|---|-------------------|
| 1 | Main Power/OK LED |
| 2 | SP OK/Fault LED |
-

After the ILOM firmware initializes, the SP OK/Fault LED remains lit, the main power OK/Fault LED slowly flashes, and the SP login prompt displays on the terminal device. The host is not initialized or powered on yet.

6. At the terminal device, log in to the SP as root with a password of changeme.

```
XXXXXXXXXXXXXXXXXXXX login: root
Password: changeme
. . .
->
```

After a brief delay, the SP prompt is displayed (->). At this point, there are many commands you can perform using the ILOM interface.

Additional SP information, such as how to change the password and how to set up the SP network parameters, is available in the ILOM online documentation set.

7. Power on the server and redirect the host output to display on the serial terminal device:

```
-> start /SYS
Are you sure you want to start /SYS (y/n)? y
-> start /HOST/console
Are you sure you want to start /HOST/CONSOLE (y/n)? y
Serial console started. To stop, type #.
. . .
```

After you start the SP host console, the server initialization takes approximately 20 minutes to complete.

8. When prompted, follow the onscreen instructions for configuring the Oracle Solaris OS on your host, and enter the following configuration information.

You will be prompted to confirm the configuration several times, enabling confirmation and changes. If you are not sure how to respond to a particular value, you can accept the default, and make future changes when the Oracle Solaris OS is running. See [“Oracle Solaris OS Configuration Parameters” on page 55](#) for more information.

9. Log in to the server and explore its capabilities.

There are many commands you can use to verify the functionality of the system, including:

- `showrev` – Displays the host name and system architecture information. Use the `-a` option with this command to see the patches that are installed.
- `psrinfo` – Displays information about the number and status of the processors and cores in the host.
- `prtdiag` – Displays system configuration and diagnostic information.

Review the Oracle Solaris OS man pages and documentation for more details.

Related Information

- Oracle Solaris documentation
- *SPARC T3 Series Servers Administration Guide*
- [“Connect a Terminal or Emulator to the SER MGT Port” on page 51](#)

Oracle Solaris OS Configuration Parameters

When configuring the Oracle Solaris OS, you will be prompted for the following configuration parameters. For more information about these settings, refer to the Oracle Solaris documentation.

Parameter	Description
Language	Select a number from the displayed languages list.
Locale	Select a number from the displayed locale list.
Terminal Type	Select a terminal type that corresponds with your terminal device.
Network?	Select Yes.
Multiple Network Interfaces	Select the network interfaces that you plan to configure. If you are not sure, select the first one in the list.
DHCP?	Select Yes or No according to your network environment.
Host Name	Type the host name for the server.
IP Address	Type the IP address for this Ethernet interface.
Subnet?	Select Yes or No according to your network environment.

Parameter	Description
Subnet Netmask	If your answer to Subnet? was Yes, type the netmask for the subnet for your network environment.
IPv6?	Specify whether or not to use IPv6. If you are not sure, select No to configure the Ethernet interface for IPv4.
Security Policy	Select either standard UNIX security (no) or Kerberos Security (Yes). If you are not sure, select No.
Confirm	When prompted with this, review the onscreen information and change it if needed. Otherwise, continue.
Name Service	Select the name service according to your network environment. Note – If you select a name service other than None, you will be prompted for additional name service configuration information.
NFSv4 Domain Name	Select the type of domain name configuration according to your environment. If you are not sure, select Use the NFSv4 domain derived by the system.
Time Zone (Continent)	Select your continent.
Time Zone (Country or Region)	Select your country or region.
Time Zone	Select the time zone.
Date and Time	Accept the default date and time, or change the values.
root Password	Type the root password twice. This password is for the superuser account for the Oracle Solaris OS on this server. This password is not the SP password.

Related Information

- Oracle Solaris OS documentation
- [“Power On the System for the First Time” on page 52](#)

▼ Assign a Static IP Address to the SP

If your network uses DHCP to assign IP addresses, the DHCP device will automatically assign an IP address to the service processor. If your network does not use DHCP, follow this procedure to assign a static IP address to the service processor.

Note – For more information on configuring ILOM, refer to the *SPARC T3 Series Servers Administration Guide* and the ILOM documentation.

1. Log in to the service processor using a serial connection through the SER MGT port.

For serial connection instructions, see [“Connect a Terminal or Emulator to the SER MGT Port” on page 51](#). Log in to the service processor as `root` (*changeme* is the default `root` password) to display the ILOM (`->`) prompt.

```
hostname login: root
Password: password (nothing displayed)

Oracle(R) Integrated Lights Out Manager

Version 3.0.12.2

Copyright (c) 2010, Oracle and/or its affiliates. All rights reserved.

Warning: password is set to factory default.
->
```

2. Set the service processor to accept a static IP address.

```
-> set /SP/network pendingipdiscovery=static
Set 'pendingipdiscovery' to 'static'
```

3. Set the IP address for the service processor.

```
-> set /SP/network pendingipaddress=service-processor-IPaddr
Set 'pendingipaddress' to 'service-processor-IPaddr'
```

4. Set the IP address for the service processor gateway.

```
-> set /SP/network pendingipgateway=gateway-IPaddr
Set 'pendingipgateway' to 'gateway-IPaddr'
```

5. Set the netmask for the service processor.

```
-> set /SP/network pendingipnetmask=255.255.255.0
Set 'pendingipnetmask' to '255.255.255.0'
```

This example uses 255.255.255.0 to set the netmask. Your network environment subnet might require a different netmask. Use a netmask number most appropriate to your environment.

6. Use the show /SP/network -display properties command to verify that the parameters were set correctly.

The code example shows parameters that have been set to convert a service processor from a DHCP configuration to a static configuration.

```
-> show /SP/network -display properties
/SP/network
Properties:
  commitpending = (Cannot show property)
  dhcp_server_ip = none
  ipaddress = xxx.xxx.xxx.xxx
  ipdiscovery = dhcp
  ipgateway = xxx.xxx.xxx.xxx
  ipnetmask = 255.255.255.0
  macaddress = 00:21:28:6F:A7:BB
  managementport = /SYS/MB/SP/NETMGMT
  outofbandmacaddress = 00:21:28:6F:A7:BB
  pendingipaddress = xxx.xxx.xxx.xxx
  pendingipdiscovery = static
  pendingipgateway = xxx.xxx.xxx.xxx
  pendingipnetmask = 255.255.255.0
  pendingmanagementport = /SYS/MB/SP/NETMGMT
  sidebandmacaddress = 00:21:F8:6F:A7:BA
  state = enabled
->
```

Note – After setting the configuration parameters, you must enter the set /SP/network commitpending=true command for the new values to take affect.

7. Commit the changes to the service processor network parameters.

```
-> set /SP/network commitpending=true
Set 'commitpending' to 'true'
```

Note – You can run the `show /SP/network` command again (after performing the `set /SP/network commitpending=true` command) to verify that the parameters have been updated.

Related Information

- *SPARC T3 Series Servers Administration Guide*
- ILOM documentation

Identifying the Server Ports

These topics provide the pin descriptions of the server ports.

- [“USB Ports” on page 62](#)
- [“SER MGT Port” on page 63](#)
- [“NET MGT Port” on page 64](#)
- [“Gigabit Ethernet Ports” on page 65](#)
- [“Video Ports” on page 66](#)
- [“SAS Connectors” on page 67](#)
- [“QSFP Port” on page 69](#)

Related Information

- [“Rear Panel Connectors and Ports” on page 37](#)
- [“Connecting the Server Cables” on page 35](#)

USB Ports

Two USB ports can be accessed from the front of the server and two from the back of the server.

FIGURE: USB Connector



Figure Legend

1	+5V supply	3	Data +
2	Data -	4	Ground

Related Information

- [“Rear Panel Connectors and Ports” on page 37](#)

SER MGT Port

The SER MGT RJ-45 port, located on the back panel, provides the default connection to the system console.

FIGURE: SER MGT Port



Figure Legend

1	Clear to Send	5	Ground
2	Data Carrier Detect	6	Receive Data
3	Transmit Data	7	Data Terminal Ready
4	Ground	8	Ready to Send

Related Information

- [“Rear Panel Connectors and Ports” on page 37](#)
- [“Connect the SER MGT Cable” on page 39](#)
- [“Connect a Terminal or Emulator to the SER MGT Port” on page 51](#)

NET MGT Port

The NET MGT RJ-45 port, located on the back panel, provides an optional Ethernet connection to the service processor.

FIGURE: NET MGT Port



Figure Legend

1	Transmit Data +	5	No Connect
2	Transmit Data –	6	Receive Data –
3	Receive Data +	7	No Connect
4	No Connect	8	No Connect

Related Information

- [“Rear Panel Connectors and Ports” on page 37](#)
- [“Connect the NET MGT Cable” on page 40](#)
- [“Assign a Static IP Address to the SP” on page 57](#)

Gigabit Ethernet Ports

Four RJ-45 Gigabit-Ethernet connectors (NET0, NET1, NET2, NET3) can be accessed from the back panel. The Ethernet interfaces operate at 10 Mbit/sec, 100 Mbit/sec, and 1000 Mbit/sec.

FIGURE: Gigabit Ethernet Port



Figure Legend

1	Transmit/Receive Data 0 +	5	Transmit/Receive Data 2 -
2	Transmit/Receive Data 0 -	6	Transmit/Receive Data 1 -
3	Transmit/Receive Data 1 +	7	Transmit/Receive Data 3 +
4	Transmit/Receive Data 2 +	8	Transmit/Receive Data 3 -

Related Information

- [“Rear Panel Connectors and Ports” on page 37](#)
- [“Connect the Ethernet Network Cables” on page 41](#)

Video Ports

The server has two 15-pin VGA video ports, one port on the front and one on the back of the server.

FIGURE: Video Connector

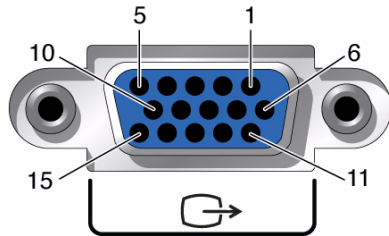

Figure Legend

1	Red Video	9	+5V
2	Green Video	10	Sync Ground
3	Blue Video	11	Monitor ID - Bit 0 (Ground)
4	Monitor ID - Bit 2 (Ground)	12	VGA 12C Serial Data
5	Ground	13	Horizontal Sync
6	Red Ground	14	Vertical Sync
7	Green Ground	15	VGA 12C Serial Clock
8	Blue Ground		

Related Information

- [“Rear Panel Connectors and Ports” on page 37](#)

SAS Connectors

The six SAS connectors are located on the drive backplane inside the server.

FIGURE: SAS Connector

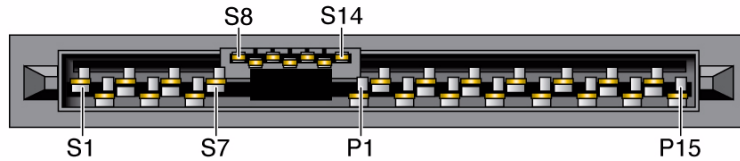

The following table lists the pinouts for the SAS connector.

TABLE: SAS Connector Pinouts

Signal Segment	S1	Gnd	Second mate	
	S2	TX+	Transmit from PHY to hard drive	
	S3	TX-		
	S4	Gnd	Second mate	
	S5	RX-	Receive from hard drive to PHY	
	S6	RX+		
	S7	Gnd	Second mate	
	Back-side Signal	S8	Gnd	Second mate
		S9		
		S10		
		S11	Gnd	Second mate
		S12		
		S13		
		S14	Gnd	Second mate

TABLE: SAS Connector Pinouts (*Continued*)

Power Segment	P1	3.3V	Not Supported
	P2	3.3V	Not Supported
	P3	3.3V	Not Supported
	P4	Gnd	First mate
	P5	Gnd	Second mate
	P6	Gnd	Second mate
	P7	5.0V	Pre-charge, second mate
	P8	5.0V	
	P9	5.0V	
	P10	Gnd	Second mate
	P11	Reserved	Should be grounded
	P12	Gnd	First mate
	P13	12.0V	Pre-charge, second mate
	P14	12.0V	
	P15	12.0V	

Related Information

- *SPARC T3-2 Server Service Manual*

QSFP Port

Oracle's SPARC T3-2 Server 10 Gb Network Module card contains one QSFP port.

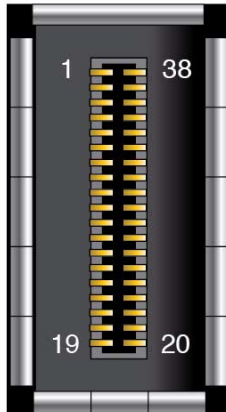

The following table lists the pinout for each connection.

Pin	Signal	Pin	Signal	Pin	Signal	Pin	Signal
1	GND	11	SCL	21	RX2n	31	Reserved
2	TX2n	12	SDA	22	RX2p	32	GND
3	TX2p	13	GND	23	GND	33	TX3p
4	GND	14	RX3p	24	RX4n	34	TX3n
5	TX4n	15	RX3n	25	RX4p	35	GND
6	TX4p	16	GND	26	GND	36	TX1p
7	GND	17	RX1p	27	ModPrsL	37	TX1n
8	ModSelL	18	RX1n	28	IntL	38	GND
9	LPMODE_Reset	19	GND	29	VccTx		
10	VccRx	20	GND	30	Vcc1		

The following table provides the QSFP signal descriptions.

Signal	Description
GND	Ground for both signal and power return
SDA	I ² C interface data
SCL	I ² C interface clock
ModSelL	Module select on low - Enables reception of I ² C commands.
ResetL	Reset on low
LPMode	Low power mode
ModPrsL	Module presence on low - Identifies existence of QSFP connector.
IntL	Interrupt on low - Enables fault indication.

Related Information

- [“Rear Panel Connectors and Ports” on page 37](#)
- [“Connect the Network Module Cables” on page 42](#)

Glossary

B

BMC baseboard management controller

C

CMA cable management arm

D

DHCP Dynamic Host Configuration Protocol

DTE data terminal equipment

E

ESD electrostatic discharge

H

HBA host bus adapter

I

ILOM Oracle Integrated Lights Out Manager

IP Internet Protocol

N

NET MGT network management port

NIC network interface card or controller

O

Oracle Solaris OS Oracle Solaris Operation System

P

POST power-on self-test

Q

QSFP quad small form-factor pluggable

S

SAS	serial attached SCSI
SER MGT	serial management port
SP	service processor
SSD	solid-state drive
SSH	Secure Shell

U

UI	user interface
UUID	Universal Unique Identifier

W

WWID	world-wide identifier. A unique number that identifies a SAS target.
-------------	--

Index

A

- AC OK LED, location of, 13
- AC power, initial power-on tasks, 50
- acoustic noise emissions, 9
- adapter for serial cables, 39
- airflow requirements, 10
- ambient temperature range, 8
- anti-tilt legs or bar, 20

B

- back panel
 - components, 13
 - ports and connectors, 37
- baud rate for serial terminal, 52
- bit setting for serial terminal, 52

C

- cable management arm (CMA)
 - cable hook and loop straps, installing, 31
 - cable strap, 32
 - installing, 28
 - mounting bracket, 29
 - securing cables, 47
 - slide rail connector, 31
 - verifying operation, 33
- cabling
 - adapter for serial data cables, 39
 - data cables, optional, 46
 - Ethernet ports, 41
 - NET MGT port, 40
 - network module, 42
 - PCIe cards, 46
 - power cords, 46
 - QSFP port, 42
 - rear port locations, 37
 - required connections, 36

- securing to CMA, 47
- SER MGT port, 39

CMA

- See* cable management arm (CMA)

configuring

- information required, 36
- Oracle Solaris OS, 55

- cooling zones, 9

- CPU description, 3

D

- DHCP, 40, 57
- diagnostics, 53
- DIMM description, 3
- drives, 3, 12
- DVD drive, 12

E

- electrical specifications, 6
- environmental requirements, 8
- ESD precautions, 15
- Ethernet ports, 4, 13
 - cabling, 41
 - location, 37
 - pinouts, 65
 - sideband management, 41

G

- gateway IP address, 36

H

- handling precautions, 14
- handshaking for serial terminal, no, 52
- humidity, ambient relative, 8

I

ILOM, 50

input power information, 7

installing

 cable management arm (CMA), 28

 mounting brackets, 22

 optional components, 16

 server into rack, 17

 slide rail assemblies, 23

 task overview, 2

IP address

 gateway, 36

 service processor, 36

 static, 57

L

LED

 AC OK, 13

 Locator button, 12

 Main Power/OK, 12, 53

 Overtemperature Warning, 13

 Power button/OK, 12

 Power Supply Fault, 12

 Service Action Required, 12

 SP OK/Fault, 12, 53

 System Status, 14

Locator button, 12

M

Main Power/OK LED, 12, 53

memory description, 3

mounting brackets

 installing, 22

 pins, 22

 release button, 21

 server installation, 26

N

NET MGT port

See network management (NET MGT) port

netmask, 36

network management (NET MGT) port

 cabling, 40

 DHCP, 40

 location, 14, 38

 pinouts, 64

 static IP address, 40

network module, 4

 cabling, 42

 slot location, 14, 37

noise emissions, 9

O

optional components, installation instructions, 16

Oracle Solaris OS

 configuration parameters, 55

 configuring, 54

overheating, avoiding, 10

Overtemperature Warning LED, 13

P

parity for serial terminal, no, 52

PCIe cards

 cabling, 46

 slots, 4, 14

physical specifications, 5

pinouts

 Ethernet ports, 65

 NET MGT port, 64

 SAS connector, 67

 SER MGT port, 63

 USB ports, 62

 video connector, 66

Power button, location of, 12

power cords, cabling, 46

power dissipation numbers, 6

power supplies, 4, 7

 AC inlet, 37

 connecting cords, 53

 fault LEDs, location of, 12

 initial power on, 50

 LEDs, 13

 power inlet, 13

 standby mode, 46

powering on for the first time, 50

precautions, handling, 14

Q

QSFP

 cabling, 42

 connector pinout, 69

 NM card slot, 37

 transceiver module, 42

R

rack

- compatibility, 18
- mounting holes, supported, 18
- posts, 23
- specifications, 18
- stabilizing, 20

rackmount

- anti-tilt legs or bar, extending, 20
- cable hook and loop straps, 31
- CMA
 - installation, 28
 - slide rail connector, 30
- installing cables, 31
- kit, 17
- mounting
 - brackets, 22
 - holes, 23
- racks, supported, 18
- safety warnings, 18
- server installation, 26
- slide rail assemblies, 23
 - stops, releasing, 33
- stabilizing the rack, 20

S

SAS connector pinouts, 67

SER MGT port

See serial management (SER MGT) port

serial management (SER MGT) port, 14

- cabling, 39
- initial power on, 51
- location, 38
- pinouts, 63

serial terminal settings, 52

server overview, 3

Service Action Required LED, 12

service processor

- described, 4
- DHCP, 57
- powering on for the first time, 52
- set command, 57
- show command, 58
- start command, 54
- static IP address, 57
- terminal connection, 51

set command, 57

shipping kit contents, 11

show /SP/network command, 58

show command, 58

sideband management, 41

slide rail assemblies

- disassembling, 20
- installing, 20, 23
- mounting pins, 23
- server installation, 26
- stops, 33
- verifying operation, 33

slide rail lock, 21

SP OK/Fault LED, 12, 53

specifications

- airflow clearance, 9
- cooling zones, 9
- electrical, 6
- environmental requirements, 8
- noise emissions, 9
- physical, 5

standby

- mode, 46
- voltage, 53

start command, 54

stop bit, 52

system status LEDs, locations of, 14

T

temperature requirements, 8

tools required, 16

U

USB ports, 3

- front, 13
- hot-plugging, 37
- pinouts, 62
- rear, 13, 37

V

video connector

- described, 3
- front, 12
- location, 38
- pinouts, 66
- rear, 14

