



# Sun Blade 1000 and Sun Blade 2000 UltraSPARC™ III Cu Module Installation Guide

---

Sun Microsystems, Inc.  
4150 Network Circle  
Santa Clara, CA 95054 U.S.A.  
650-960-1300

Part No. 816-3221-12  
June 2004, Revision A

Submit comments about this document at: <http://www.sun.com/hwdocs/feedback/>

Copyright 2004 Sun Microsystems, Inc., 4150 Network Circle, Santa Clara, Ca. 95054 U.S.A. All rights reserved.

This product or document is distributed under licenses restricting its use, copying, distribution, and decompilation. No part of this product or document may be reproduced in any form by any means without prior written authorization of Sun and its licensors, if any. Third-party software, including font technology, is copyrighted and licensed from Sun suppliers.

Parts of the product may be derived from Berkeley BSD systems, licensed from the University of California. UNIX is a registered trademark in the U.S. and other countries, exclusively licensed through X/Open Company, Ltd.

Sun, Sun Microsystems, the Sun logo, docs.sun.com, OpenBoot, ShowMe How, Sun Blade, and Solaris are trademarks, registered trademarks, or service marks of Sun Microsystems, Inc. in the U.S. and other countries. All SPARC trademarks are used under license and are trademarks or registered trademarks of SPARC International, Inc. in the U.S. and other countries. Products bearing SPARC trademarks are based upon an architecture developed by Sun Microsystems, Inc.

The OPEN LOOK and Sun™ Graphical User Interface was developed by Sun Microsystems, Inc. for its users and licensees. Sun acknowledges the pioneering efforts of Xerox in researching and developing the concept of visual or graphical user interfaces for the computer industry. Sun holds a non-exclusive license from Xerox to the Xerox Graphical User Interface, which license also covers Sun's licensees who implement OPEN LOOK GUIs and otherwise comply with Sun's written license agreements.

Federal Acquisitions: Commercial Software—Government Users Subject to Standard License Terms and Conditions.

DOCUMENTATION IS PROVIDED "AS IS" AND ALL EXPRESS OR IMPLIED CONDITIONS, REPRESENTATIONS AND WARRANTIES, INCLUDING ANY IMPLIED WARRANTY OF MERCHANTABILITY, FITNESS FOR A PARTICULAR PURPOSE OR NON-INFRINGEMENT, ARE DISCLAIMED, EXCEPT TO THE EXTENT THAT SUCH DISCLAIMERS ARE HELD TO BE LEGALLY INVALID.

---

Copyright 2004 Sun Microsystems, Inc., 4150 Network Circle, Santa Clara, Ca. 95054 U.S.A. Etats-Unis. Tous droits réservés.

Ce produit ou document est distribué avec des licences qui en restreignent l'utilisation, la copie, la distribution, et la décompilation. Aucune partie de ce produit ou document ne peut être reproduite sous aucune forme, par quelque moyen que ce soit, sans l'autorisation préalable et écrite de Sun et de ses bailleurs de licence, s'il y en a. Le logiciel détenu par des tiers, et qui comprend la technologie relative aux polices de caractères, est protégé par un copyright et licencié par des fournisseurs de Sun.

Des parties de ce produit pourront être dérivées des systèmes Berkeley BSD licenciés par l'Université de Californie. UNIX est une marque déposée aux Etats-Unis et dans d'autres pays et licenciée exclusivement par X/Open Company, Ltd.

Sun, Sun Microsystems, le logo Sun, docs.sun.com, OpenBoot, ShowMe How, Sun Blade, et Solaris sont des marques de fabrique ou des marques déposées, ou marques de service, de Sun Microsystems, Inc. aux Etats-Unis et dans d'autres pays. Toutes les marques SPARC sont utilisées sous licence et sont des marques de fabrique ou des marques déposées de SPARC International, Inc. aux Etats-Unis et dans d'autres pays. Les produits portant les marques SPARC sont basés sur une architecture développée par Sun Microsystems, Inc.

L'interface d'utilisation graphique OPEN LOOK et Sun™ a été développée par Sun Microsystems, Inc. pour ses utilisateurs et licenciés. Sun reconnaît les efforts de pionniers de Xerox pour la recherche et le développement du concept des interfaces d'utilisation visuelle ou graphique pour l'industrie de l'informatique. Sun détient une licence non exclusive de Xerox sur l'interface d'utilisation graphique Xerox, cette licence couvrant également les licenciés de Sun qui mettent en place l'interface d'utilisation graphique OPEN LOOK et qui en outre se conforment aux licences écrites de Sun.

Achats fédéraux : logiciel commercial - Les utilisateurs gouvernementaux doivent respecter les conditions du contrat de licence standard.

LA DOCUMENTATION EST FOURNIE "EN L'ETAT" ET TOUTES AUTRES CONDITIONS, DECLARATIONS ET GARANTIES EXPRESSES OU TACITES SONT FORMELLEMENT EXCLUES, DANS LA MESURE AUTORISEE PAR LA LOI APPLICABLE, Y COMPRIS NOTAMMENT TOUTE GARANTIE IMPLICITE RELATIVE A LA QUALITE MARCHANDE, A L'APTITUDE A UNE UTILISATION PARTICULIERE OU A L'ABSENCE DE CONTREFAÇON.



# Contents

---

|  |          |
|--|----------|
| <b>Regulatory Compliance Statements</b>  | <b>v</b> |
| <b>Sun Blade 1000 and Sun Blade 2000 UltraSPARC III Cu CPU Module Installation Guide</b> | <b>1</b> |
| Installation Kit Contents  | 1        |
| Rules for Installing Cu CPU Modules  | 2        |
| Sun Blade 1000 Workstation Configuration Rules   | 3        |
| Sun Blade 2000 Workstation Configuration Rules   | 3        |
| Identifying Cu CPU Modules   | 3        |
| Identifying a CPU Module   | 3        |
| OpenBoot PROM and Software Requirements for UltraSPARC III Cu CPU Modules                | 5        |
| Installing the UltraSPARC III Cu CPU Module  | 5        |
| Verifying Software and Hardware Compatibility  | 5        |
| Preparing for Installation   | 6        |
| Powering Off the Workstation   | 6        |
| Verifying Power Off  | 7        |
| Removing the Access Panel  | 9        |
| Attaching the Disposable Antistatic Wrist Strap  | 11       |
| CPU Module Positions in the Workstation  | 12       |
| Removing a CPU Module  | 13       |

|                                |    |
|--------------------------------|----|
| Installing a New CPU Module    | 17 |
| Finishing the Installation     | 25 |
| Where to Find More Information | 26 |

# Regulatory Compliance Statements

Your Sun product is marked to indicate its compliance class:

- Federal Communications Commission (FCC) — USA
- Industry Canada Equipment Standard for Digital Equipment (ICES-003) - Canada
- Voluntary Control Council for Interference (VCCI) — Japan
- Bureau of Standards Metrology and Inspection (BSMI) — Taiwan

Please read the appropriate section that corresponds to the marking on your Sun product before attempting to install the product.

## FCC Class A Notice

This device complies with Part 15 of the FCC Rules. Operation is subject to the following two conditions:

1. This device may not cause harmful interference.
2. This device must accept any interference received, including interference that may cause undesired operation.

**Note:** This equipment has been tested and found to comply with the limits for a Class A digital device, pursuant to Part 15 of the FCC Rules. These limits are designed to provide reasonable protection against harmful interference when the equipment is operated in a commercial environment. This equipment generates, uses, and can radiate radio frequency energy, and if it is not installed and used in accordance with the instruction manual, it may cause harmful interference to radio communications. Operation of this equipment in a residential area is likely to cause harmful interference, in which case the user will be required to correct the interference at his own expense.

**Shielded Cables:** Connections between the workstation and peripherals must be made using shielded cables to comply with FCC radio frequency emission limits. Networking connections can be made using unshielded twisted-pair (UTP) cables.

**Modifications:** Any modifications made to this device that are not approved by Sun Microsystems, Inc. may void the authority granted to the user by the FCC to operate this equipment.

## FCC Class B Notice

This device complies with Part 15 of the FCC Rules. Operation is subject to the following two conditions:

1. This device may not cause harmful interference.
2. This device must accept any interference received, including interference that may cause undesired operation.

**Note:** This equipment has been tested and found to comply with the limits for a Class B digital device, pursuant to Part 15 of the FCC Rules. These limits are designed to provide reasonable protection against harmful interference in a residential installation. This equipment generates, uses and can radiate radio frequency energy and, if not installed and used in accordance with the instructions, may cause harmful interference to radio communications. However, there is no guarantee that interference will not occur in a particular installation. If this equipment does cause harmful interference to radio or television reception, which can be determined by turning the equipment off and on, the user is encouraged to try to correct the interference by one or more of the following measures:

- Reorient or relocate the receiving antenna.
- Increase the separation between the equipment and receiver.
- Connect the equipment into an outlet on a circuit different from that to which the receiver is connected.
- Consult the dealer or an experienced radio/television technician for help.

**Shielded Cables:** Connections between the workstation and peripherals must be made using shielded cables in order to maintain compliance with FCC radio frequency emission limits. Networking connections can be made using unshielded twisted pair (UTP) cables.

**Modifications:** Any modifications made to this device that are not approved by Sun Microsystems, Inc. may void the authority granted to the user by the FCC to operate this equipment.

## ICES-003 Class A Notice - Avis NMB-003, Classe A

This Class A digital apparatus complies with Canadian ICES-003.

Cet appareil numérique de la classe A est conforme à la norme NMB-003 du Canada.

## ICES-003 Class B Notice - Avis NMB-003, Classe B

This Class B digital apparatus complies with Canadian ICES-003.

Cet appareil numérique de la classe B est conforme à la norme NMB-003 du Canada.

## VCCI 基準について

### クラス A VCCI 基準について

クラス A VCCI の表示があるワークステーションおよびオプション製品は、クラス A 情報技術装置です。これらの製品には、下記の項目が該当します。

この装置は、情報処理装置等電波障害自主規制協議会 (VCCI) の基準に基づくクラス A 情報技術装置です。この装置を家庭環境で使用すると電波妨害を引き起こすことがあります。この場合には使用者が適切な対策を講ずるよう要求されることがあります。

### クラス B VCCI 基準について

クラス B VCCI の表示  があるワークステーションおよびオプション製品は、クラス B 情報技術装置です。これらの製品には、下記の項目が該当します。

この装置は、情報処理装置等電波障害自主規制協議会 (VCCI) の基準に基づくクラス B 情報技術装置です。この装置は、家庭環境で使用することを目的としていますが、この装置がラジオやテレビジョン受信機に近接して使用されると、受信障害を引き起こすことがあります。取扱説明書に従って正しい取り扱いをしてください。

## BSMI Class A Notice

The following statement is applicable to products shipped to Taiwan and marked as Class A on the product compliance label.

警告使用者：  
這是甲類的資訊產品，在居住的環境中使用時，可能會造成射頻干擾，在這種情況下，使用者會被要求採取某些適當的對策。





# Sun Blade 1000 and Sun Blade 2000 UltraSPARC III Cu CPU Module Installation Guide

---

This document describes how to remove or install an UltraSPARC<sup>®</sup> III Cu CPU module for the Sun Blade<sup>™</sup> 1000 or Sun Blade 2000 workstation. The following topics are discussed:

- “Installation Kit Contents” on page 1
- “Rules for Installing Cu CPU Modules” on page 2
- “Identifying Cu CPU Modules” on page 3
- “OpenBoot PROM and Software Requirements for UltraSPARC III Cu CPU Modules” on page 5
- “Installing the UltraSPARC III Cu CPU Module” on page 5
- “Where to Find More Information” on page 26

---

**Note** – To install an UltraSPARC III 600, 750, or 900 MHz *non Cu* CPU module in a Sun Blade 1000 workstation, see the *Sun Blade 1000 UltraSPARC III Module Installation Instructions*, 816-0416-11.

---

---

## Installation Kit Contents

Your UltraSPARC III Cu CPU module installation kit contains:

- UltraSPARC III Cu CPU module
- CPU torque tool
- Disposable antistatic wrist strap

- Antistatic mat
- The UltraSPARC Cu CPU Module Installation Guide Roadmap, 816-2721, which describes other documents you may need.

---

## Rules for Installing Cu CPU Modules

You should verify which CPU modules are installed in your workstation before you purchase or install new CPU modules.

---

**Note** – UltraSPARC III Cu CPU modules are marked “USIII Cu,” “USIII Cu-A,” “USIII Cu-B,” or “USIII Cu-C” (FIGURE 1).

---

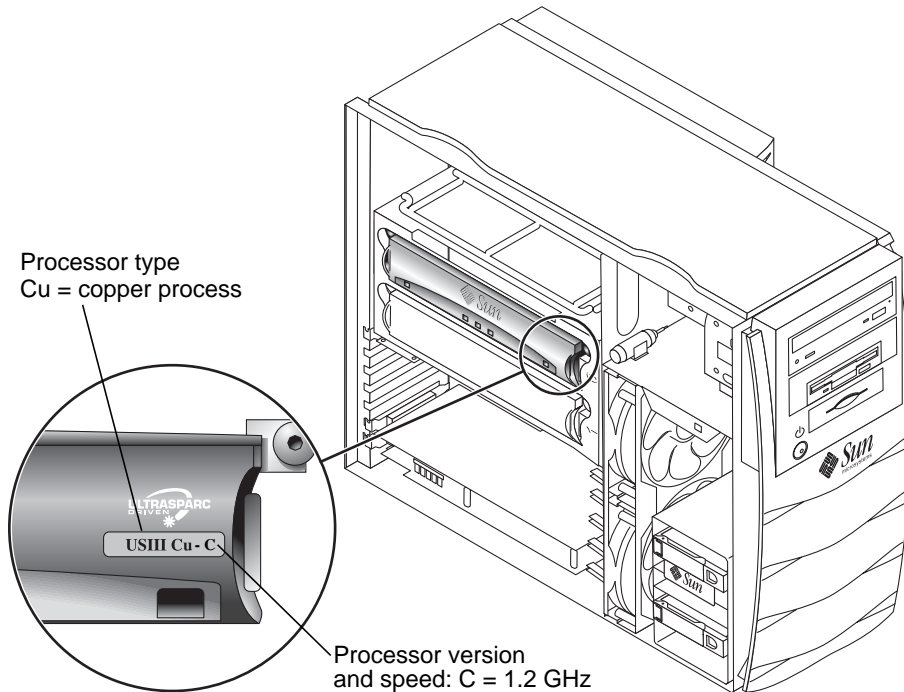

**FIGURE 1** Label on a 1.200 GHz UltraSPARC III Cu CPU Module

## Sun Blade 1000 Workstation Configuration Rules

- You can install UltraSPARC III *Cu* modules into a Sun Blade 1000 workstation. However, both modules *must* be identical UltraSPARC III *Cu* modules. If the module types are mixed (not identical), the workstation will not boot.
- Always install the first CPU module into CPU slot 0 (connectors J0501 and J0601).
- If you install a second CPU module, install it into CPU slot 1 (connectors J0701 and J0801).

## Sun Blade 2000 Workstation Configuration Rules

- The Sun Blade 2000 workstation only operates with UltraSPARC III *Cu* CPU modules.
- If two *Cu* CPUs are installed, they *must* be identical speeds. For example, two 1.200 GHz *Cu-C* modules, or two 900 MHz *Cu* modules.

---

## Identifying *Cu* CPU Modules

### Identifying a CPU Module

There are three ways to identify a CPU module:

- Type the correct `prtdiag` command in a terminal window.
- Inspect the CPU module for an UltraSPARC III *Cu* label
- Check the part number label. (This method requires you to remove the module from the workstation and is not recommended unless absolutely necessary.)

### Software Method

In a terminal window, type one of these commands:

```
/usr/platform/SUNW,Sun-Blade-1000/sbin/prtdiag
```

The system displays CPU information similar to CODE EXAMPLE 1.

**CODE EXAMPLE 1** Identifying a Workstation CPU Using `prtdiag`

```
% /usr/platform/SUNW,Sun-Blade-1000/sbin/prtdiag

===== CPUs =====
CPU      Freq      E$      CPU      CPU      Temperature
CPU      Freq      Size    Implementation  Mask    Die      Amb.    Location
----      -
0      1056 MHz  8MB      SUNW,UltraSPARC-III+  2.3    76C     21C    +-board/cpu0
1      1056 MHz  8MB      SUNW,UltraSPARC-III+  2.3    78C     21C    +-board/cpu1
```

**Note** – The 1.050 GHz CPU appears as 1056 MHz. UltraSPARC-III+ indicates a Cu module.

## Module Label Method

All Cu CPU modules have an UltraSPARC III Cu label on the front of the CPU module. See FIGURE 1 and TABLE 1.

A part number label is also affixed to the printed circuit board of every CPU module.

**Note** – Avoid removing modules just to check the part number. First use the `prtdiag` command or verify Cu modules by reading the label on the UltraSPARC III Cu module.

**TABLE 1** CPU Module Part Number, Speed, and Type

| Part Number Prefix | CPU Module Speed and Type   | CPU Label  | System                           |
|--------------------|-----------------------------|------------|----------------------------------|
| 501-6002xxxxxx     | 900 MHz UltraSPARC III Cu   | USIII Cu   |                                  |
| 501-6299xxxxxx     | 1.015 GHz UltraSPARC III Cu | USIII Cu-A |                                  |
| 501-6395xxxxxx     | 1.015 GHz UltraSPARC III Cu | USIII Cu-A | Sun Blade 1000<br>Sun Blade 2000 |
| 501-6254xxxxxx     | 1.050 GHz UltraSPARC III Cu | USIII Cu-B |                                  |
| 501-6396xxxxxx     | 1.050 GHz UltraSPARC III Cu | USIII Cu-B |                                  |
| 501-6485xxxxxx     | 1.200 GHz UltraSPARC III Cu | USIII Cu-C | Sun Blade 2000                   |

---

# OpenBoot PROM and Software Requirements for UltraSPARC III Cu CPU Modules

You may need to upgrade your workstation's OpenBoot™ PROM firmware, the Solaris operating environment (OE) and related patches. TABLE 2 lists the minimum software versions necessary for installing Cu CPU modules.

**TABLE 2** Minimum OpenBoot PROM and Solaris Operating Environment

|                                      | Sun Blade 1000  | Sun Blade 2000  |                    |                 |
|--------------------------------------|---|-----------------|--------------------|-----------------|
| <b>Solaris Operating Environment</b> | Solaris 8 10/01   | Solaris 8 02/02 | Solaris 8 HW 12/02 | Solaris 9 12/02 |
| <b>OpenBoot PROM (OBP)</b>           | 4.4.4   | 4.5.10          | 4.5.21             | 4.5.21          |
| <b>Solaris Patches</b>               | Obtain the latest patches for your Solaris operating environment at:<br><a href="http://www.sunsolve.sun.com">http://www.sunsolve.sun.com</a> |                 |                    |                 |

---

**Note** – Always check the Sun web site for the latest compatible operating environment, firmware, and software updates for your workstation.

---

---

## Installing the UltraSPARC III Cu CPU Module

Before installing an UltraSPARC III Cu CPU module, verify the hardware and software compatibility as described in the next section.

### Verifying Software and Hardware Compatibility

1. **Verify that the CPUs you intend to install are compatible.**

See “Rules for Installing Cu CPU Modules” on page 2

2. Verify that the correct version of OpenBoot PROM firmware is installed on your workstation (TABLE 2).

Type the following command in a terminal window:

```
/usr/platform/sun4u/sbin/prtdiag -v
```

3. Verify that the correct version of the Solaris operating environment is installed on your workstation (TABLE 2).

Type the following command in a terminal window:

```
more /etc/release
```

4. Download the latest patches for your version of the Solaris operating environment.

---

**Note** – You must install the correct Solaris operating environment and OpenBoot PROM versions before installing the CPU, or the system will not boot.

---

## Preparing for Installation

This section describes how to:

- Power off the workstation
- Remove the access panel
- Attach an antistatic wrist strap

---

**Note** – If you are returning a used CPU module to Sun Microsystems, return the used CPU module in the shipping box and packing materials that came with your new or replacement CPU module.

---

## Powering Off the Workstation



---

**Caution** – Before you turn off the power, save, back up, and close any open files. Notify any affected users that you are powering off your workstation.

---

### To power off the Workstation When the Solaris OE *is* Running

1. Save any open files or work in progress.

2. Press and release the keyboard sleep key or the front panel power switch (FIGURE 2).
3. From the menu displayed on the system monitor, select Shutdown.

## To Power Off the Workstation When the System is at the *ok* Prompt (OpenBoot PROM Interface)

1. Press and hold the front panel power switch for four seconds (FIGURE 2) to power off the workstation.

This action forces an immediate power off of the workstation. Any unsaved data is lost.

---

## Verifying Power Off



---

**Caution** – Pressing the power switch does not remove all power from the workstation. A trickle current remains in the power supply. To remove all power from the workstation, disconnect the power cord.

---

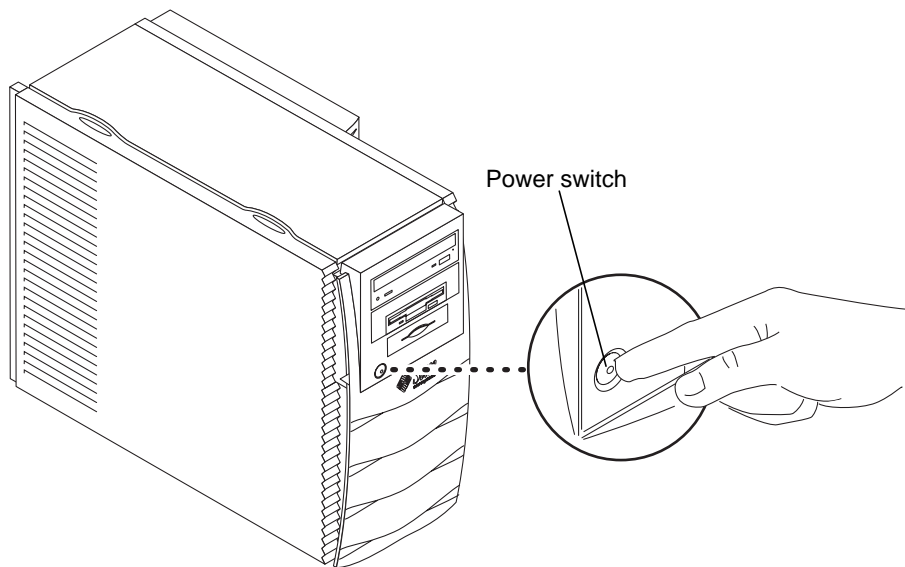

**FIGURE 2** Workstation Power Switch

1. **Verify the following:**
  - The backlit Sun Glogo on the front panel is off.
  - The workstation fans are not spinning.
2. **Turn off power to the monitor and other external peripherals.**
3. **Disconnect the cables for any peripheral equipment.**
4. **Remove the lock block, if one is installed (FIGURE 3).**

If necessary, use a Phillips screwdriver to remove the screw and lock block.

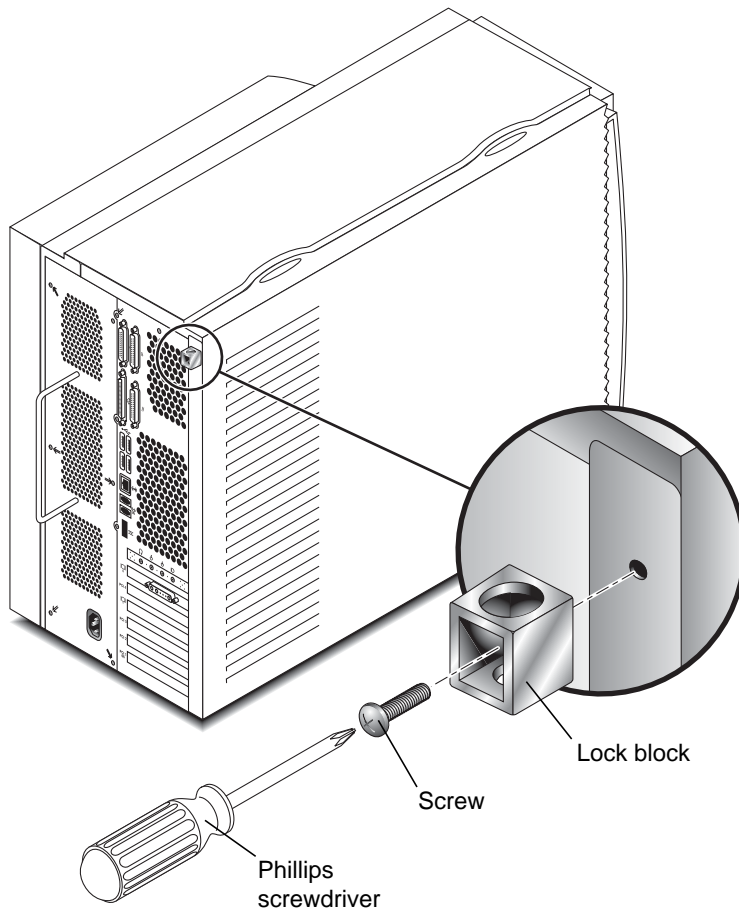

**FIGURE 3** Removing the Lock Block



# Removing the Access Panel

---

**Note** – If the power cord is connected, removal of the access panel activates the workstation power interlock circuit. This safety mechanism prevents all DC voltages (except +5 VDC standby power) from reaching any internal components.

---

1. Press down on the two depressions at the top of the access panel (FIGURE 4).
2. Tilt the top of the access panel about an inch (1.5 cm) away from the chassis.
3. Lift the access panel up.
4. Lift the access panel off.

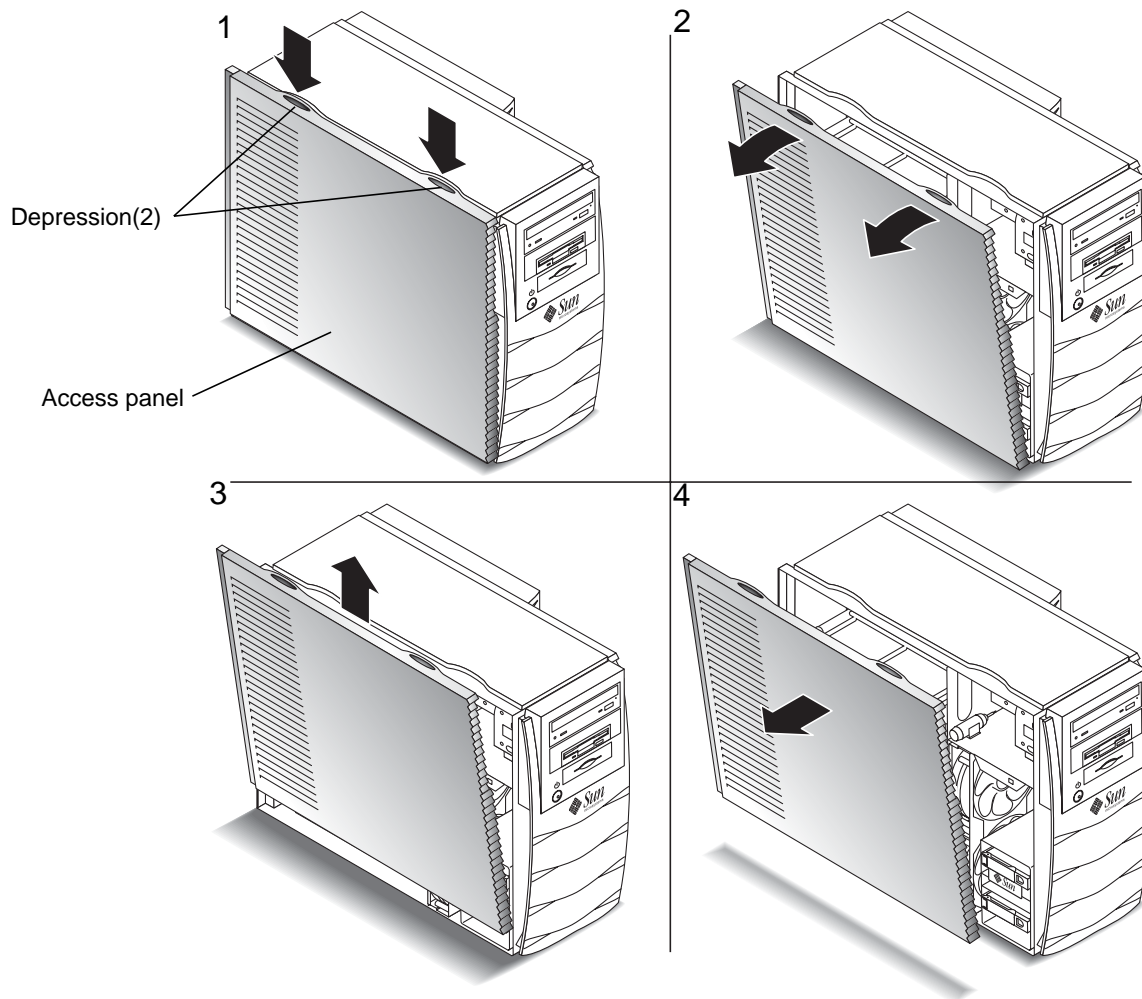

**FIGURE 4** Removing the Access Panel

# Attaching the Disposable Antistatic Wrist Strap



**Caution** – Wear an antistatic wrist strap and use an antistatic mat when handling Sun Blade 1000 and Sun Blade 2000 components. Before servicing or removing workstation components, attach the strap to your wrist and then to a metal area on the chassis. Then disconnect the power cord from the workstation and the wall receptacle. This procedure equalizes all electrical potentials within the workstation.

1. Place the workstation on its side on a work surface, open side facing up (FIGURE 5).
2. Unwrap the first two folds of the disposable antistatic wrist strap and wrap the adhesive side firmly against your wrist.
3. Peel the liner from the copper foil at the opposite end of the wrist strap.
4. Attach the copper end of the wrist strap to the chassis (FIGURE 5).
5. Disconnect the power cord.

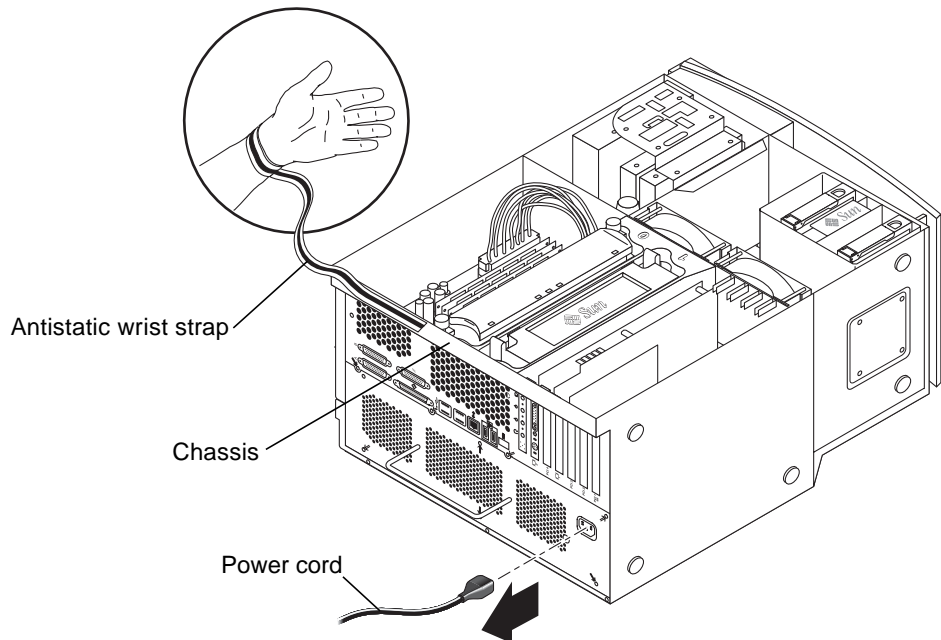

**FIGURE 5** Attaching the Antistatic Wrist Strap to the Chassis

# CPU Module Positions in the Workstation



**Caution** – If the workstation has only one CPU, that CPU must be installed in CPU processor slot 0 (connectors J0501 and J0601) See FIGURE 6.

The CPU modules are enclosed in a cooling shroud and secured to the shroud with captive screws that must be torqued to specific values.

**Note** – Beginning in June 2004, CPU torque tools are not shipped in the Sun Blade 2000 workstation. The torque tools are shipped with the CPU modules.

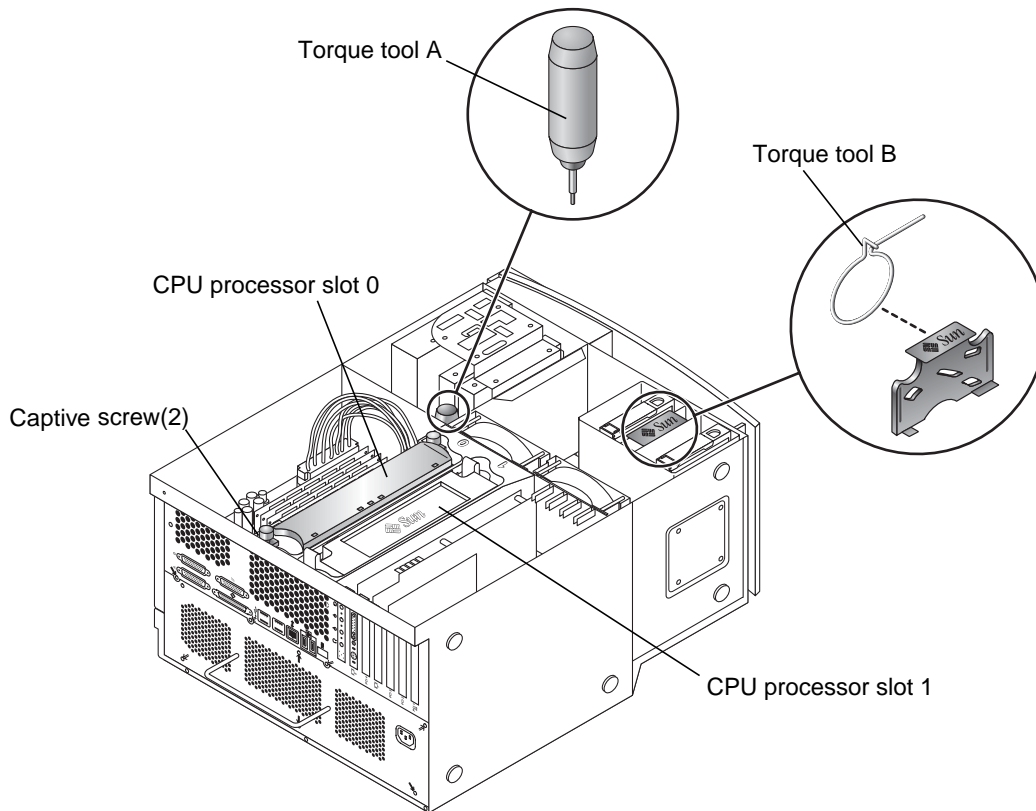
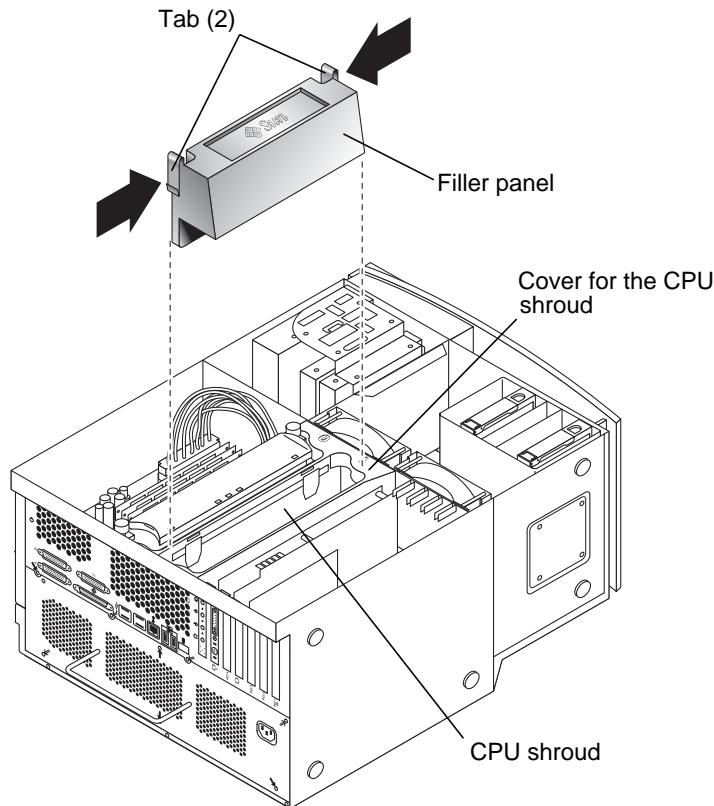

**FIGURE 6** Location of CPU Processor Slot 0, Captive Screws, and Torque Tools

# Removing a CPU Module

1. If necessary, place the workstation on its side on a work surface, open side facing up (FIGURE 6).
2. Remove torque tool A or torque tool B from the workstation or find the torque tool in the new CPU module box.
3. If necessary, remove the filler panel (FIGURE 7).

Squeeze the two tabs on the filler panel to release it from the cover for the CPU shroud.



**FIGURE 7** Removing the Filler Panel

4. Complete one of the following steps:

Your selection depends on whether you are replacing an existing UltraSPARC III Cu CPU module or installing an additional UltraSPARC III Cu CPU module into an unused CPU processor slot.

- If you are replacing an existing module and have torque tool A, perform Step 5.

- If you are replacing an existing module and have torque tool B, perform Step 6.
- If you are installing an additional CPU module, perform Step 7.

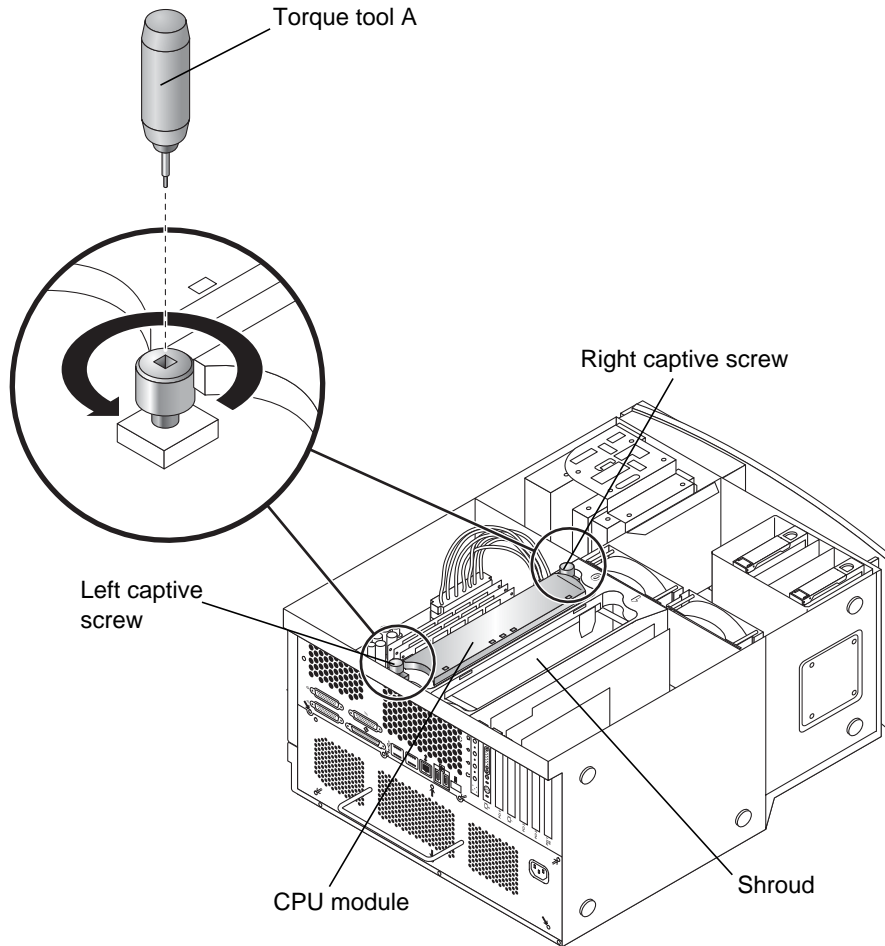

**FIGURE 8** Using Torque Tool A to Remove the CPU Module

**5. To remove an existing CPU module using torque tool A:**

- Alternately rotate the left and right captive screws one turn counterclockwise until the screws are free of the threaded inserts (FIGURE 8).**



---

**Caution** – Do not touch the board for the CPU module or its components. Touch only the captive screws and plastic top cover of the module to avoid damaging module components by electrostatic discharge (FIGURE 11).

---

- b. Use both hands to lift the CPU module out of the shroud.
  - c. Place the CPU module on an antistatic mat with the heat sink on the top facing up.
  - d. Proceed to “Installing a New CPU Module” on page 17.
6. To remove an existing CPU module using torque tool B:
- a. Remove the cover for the CPU shroud (FIGURE 9).  
Squeeze the two tabs to release the cover for the CPU shroud from the motherboard.

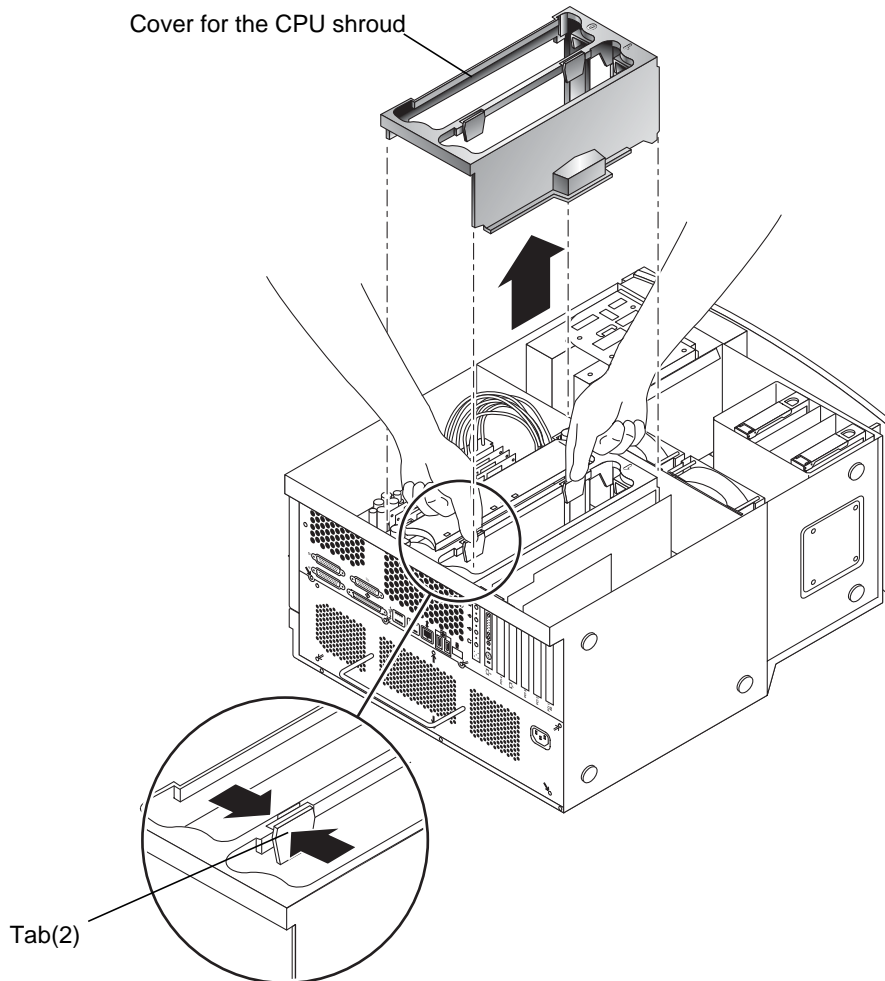

**FIGURE 9** Removing the Cover for the CPU Shroud

- b. Alternately rotate the left and right captive screws one turn counterclockwise until the screws are free of the threaded inserts (FIGURE 10).

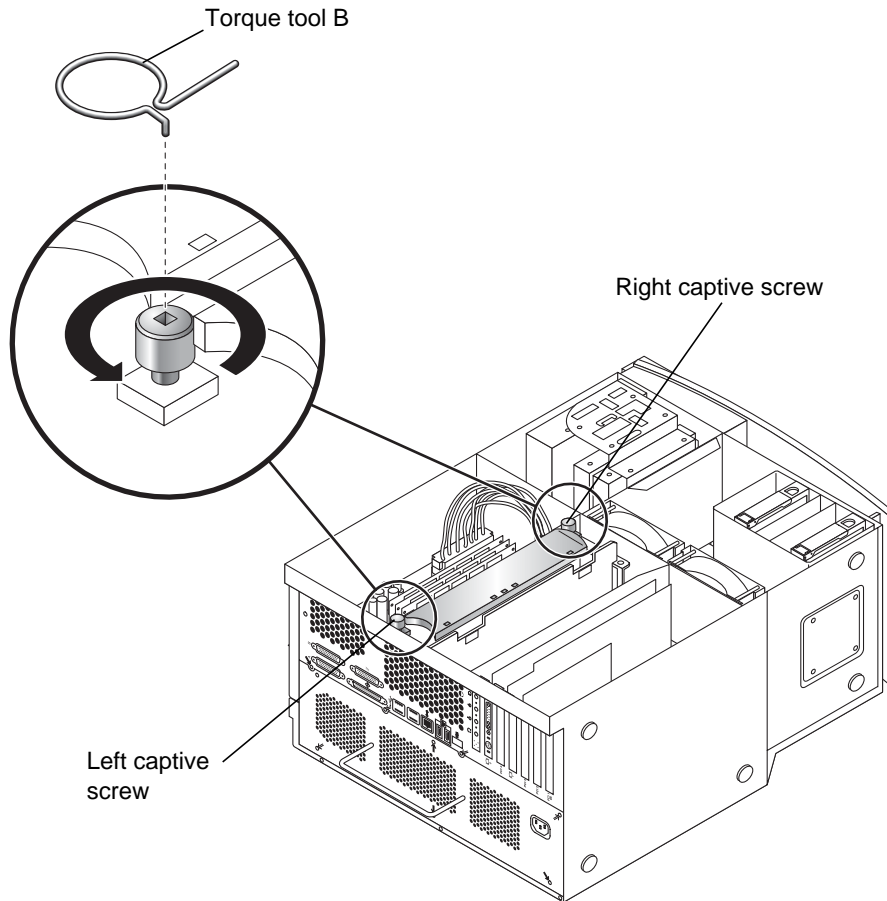

**FIGURE 10** Using Torque Tool B to Remove the CPU Module



---

**Caution** – As you remove the module from the shroud, handle it only by its captive screws. Do not touch the connectors on the bottom edge of the module or the electrical components on the module. The connectors and the components for the module are easily bent or damaged by improper handling and by electrostatic discharge (FIGURE 11).

---

- c. Use both hands to lift the CPU module out of the shroud.
- d. Place the CPU module on an antistatic mat with the heat sink on the top facing up.



7. Proceed to “Installing a New CPU Module” on page 17.

## Installing a New CPU Module



---

**Caution** – Perform the procedures described in TABLE 3 when unpacking a new CPU module from its packing carton.

---

**TABLE 3** CPU Module Handling Procedures

| Step | Description  |
|------|--|
| 1    | Use proper ESD grounding techniques when handling components. Wear an antistatic wrist strap and use an antistatic mat. Store ESD-sensitive components in antistatic bags before placing them on any surface.                        |
| 2    | When you remove the CPU module from its packing carton, use both hands to support the module along its sides. Do not grip the module by the heat sink.   |
| 3    | As you remove the module from its antistatic bag, handle it only by its captive screws. Do not touch the connectors on the bottom edge of the module. The connectors for the module are easily bent or damaged by improper handling. |
| 4    | Do not remove the plastic cover from the CPU module connectors until you are ready to install the module into the workstation.   |
| 5    | Before you install the module, carefully inspect the connector pins to ensure that they are not damaged. Never attempt to install a module that has bent or damaged connectors.  |

1. Remove the plastic cover from the CPU module connector (FIGURE 11).

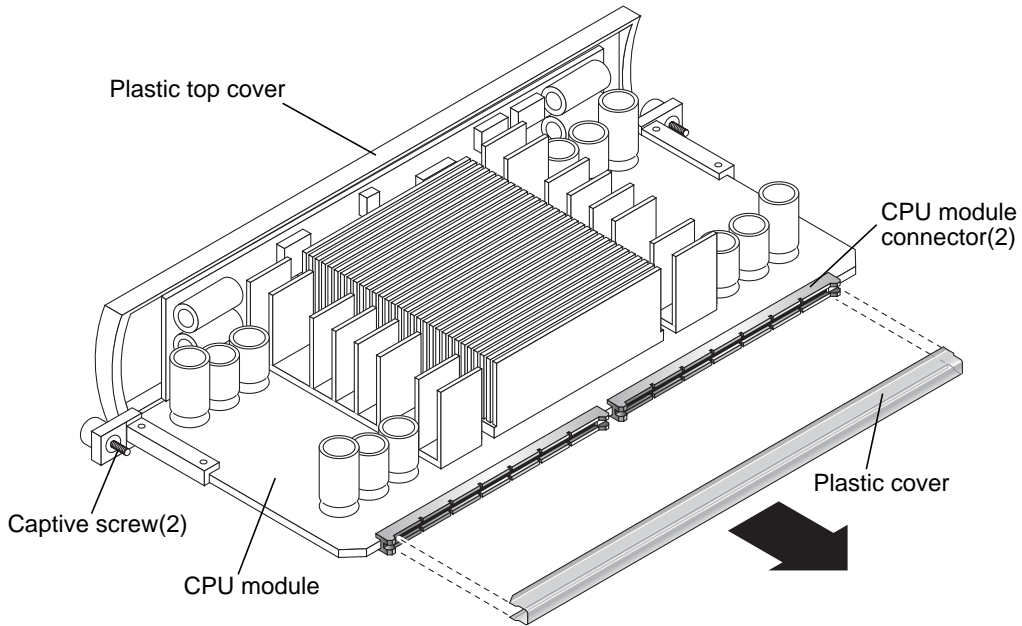

**FIGURE 11** Removing the Plastic Cover From the CPU Module Connectors

2. Lower the CPU module into the CPU shroud until the captive screws are aligned with the two threaded inserts (FIGURE 12).

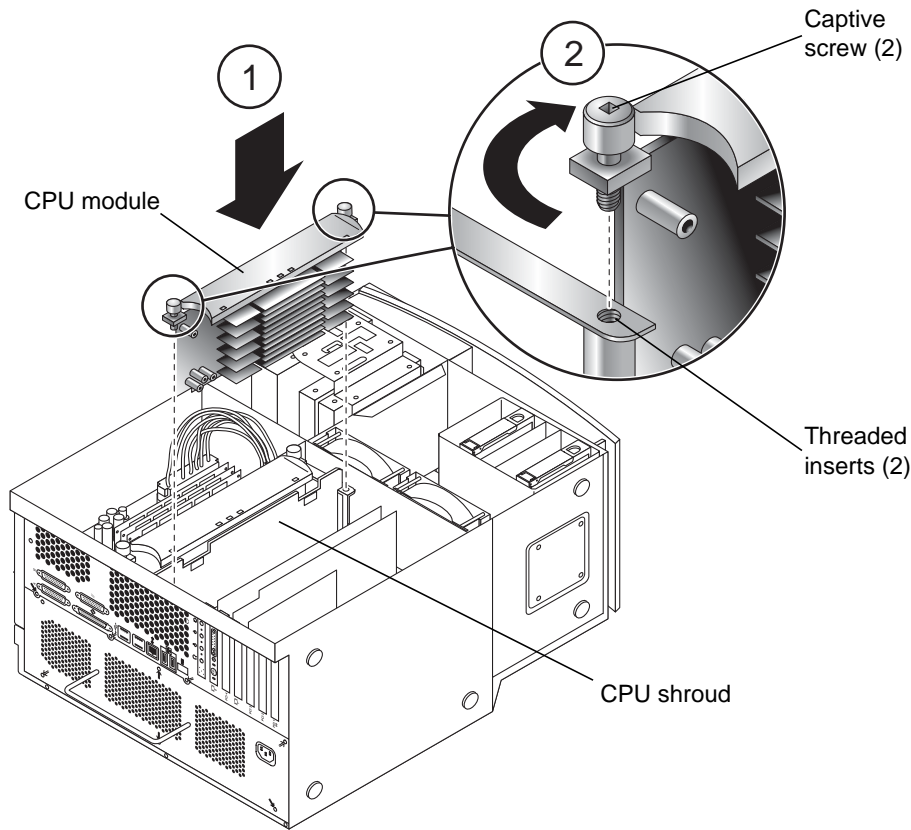

**FIGURE 12** Lowering the CPU Module Into the Threaded Inserts

**3. Tighten both captive screws by hand until the screws contact the threaded inserts of the CPU shroud.**

Once the CPU module is seated, surface contact between the captive screws and the threaded inserts of the shroud typically occurs in less than one turn of both left and right captive screws.

4. Do one of the following:

- a. If you have torque tool A, perform steps 10-16 (FIGURE 6).
- b. If you have torque tool B, perform steps 5-9 and 14-16 (FIGURE 6).

5. Use torque tool B to rotate the left captive screw one turn clockwise (FIGURE 13).



---

**Caution** – Do not use a torque tool from another Sun product. The Sun Blade 1000 and Sun Blade 2000 torque tools are designed specifically for your workstation.

---

6. Use torque tool B to rotate the right captive screw one turn clockwise (FIGURE 13).

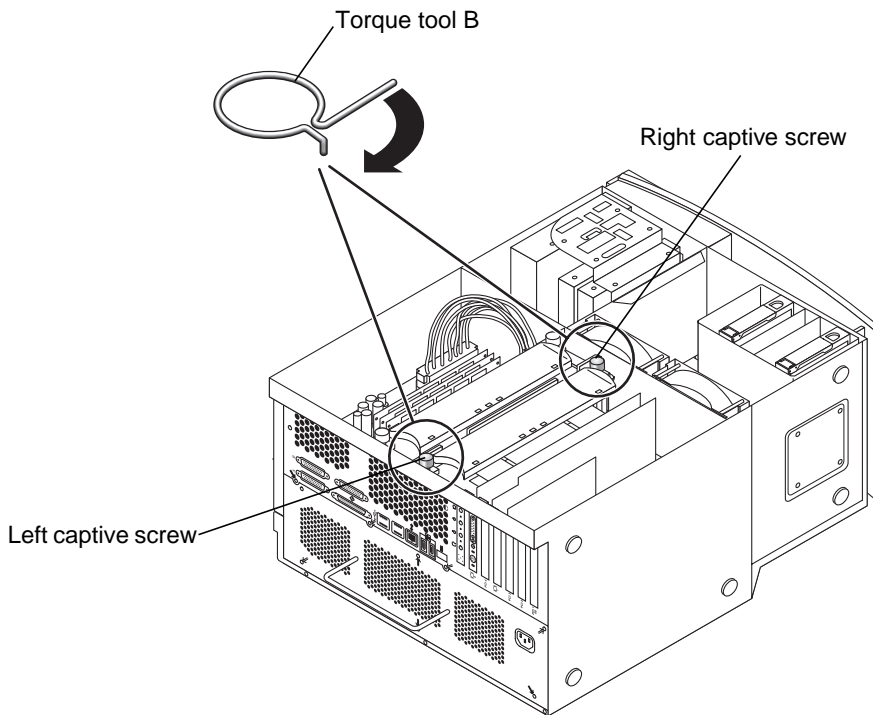

**FIGURE 13** Alternately Rotating Left and Right Captive Screws One Turn Clockwise



---

**Caution** – If you under-torque the CPU module captive screws, the contact between the CPU module and the motherboard connector might be insufficient and the workstation might not boot. Over-torquing the CPU module captive screws might cause severe damage to the module and a potential workstation failure.

---

7. Repeat Step 5 and Step 6 until the gap for torque tool B is 0.0 inches (0.0 mm) See FIGURE 14.

Use the torque tool to tighten the left and right captive screws to the correct torque. Always rotate the left captive screw one turn clockwise and then rotate the right captive screw one turn clockwise. This assures that a uniform and even torque is applied to the CPU module.

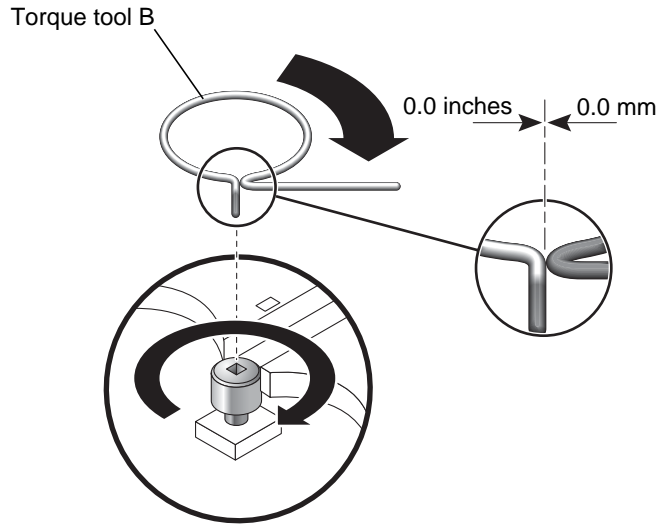

**FIGURE 14** Adjusting Torque Tool B Until the Gap is 0.0 Inches (0.0 mm).

8. Return torque tool B to its green plastic holder, then return the holder to its storage location in the hard drive bracket.
9. If necessary install the cover for the CPU shroud (FIGURE 15).

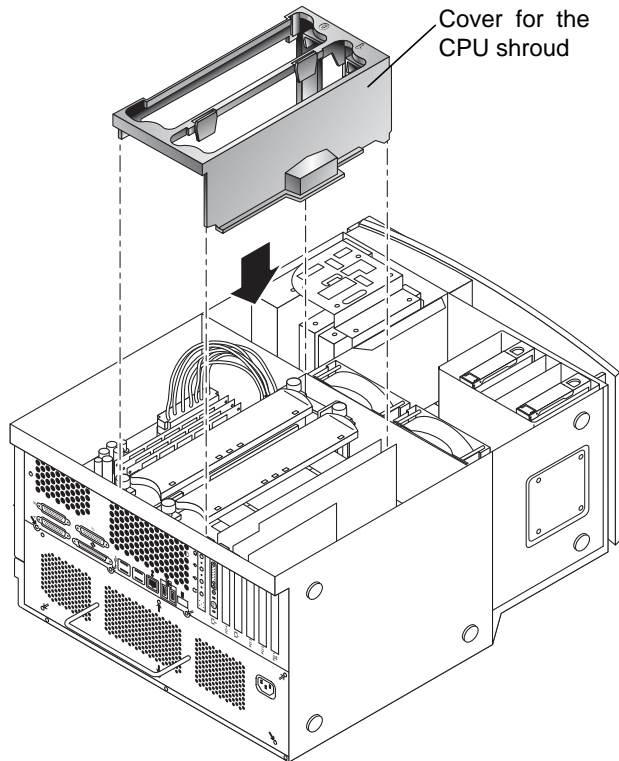

**FIGURE 15** Installing the Cover for the Shroud

- 10. Use torque tool A to rotate the left captive screw one turn clockwise (FIGURE 16).**  
If the torque tool clicks, stop. Do not attempt to torque the captive screw anymore.
- 11. Use torque tool A to rotate the right captive screw one turn clockwise (FIGURE 16).**  
If the torque tool clicks, stop. Do not attempt to torque the captive screw anymore.

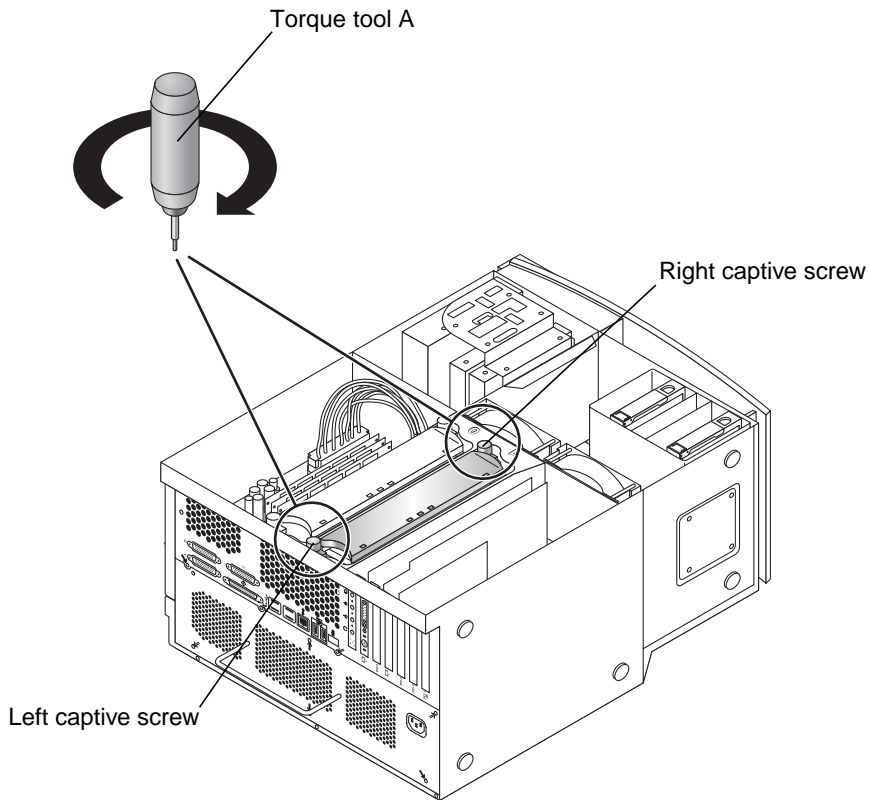

**FIGURE 16** Alternately Rotating Left and Right Captive Screws One Turn Clockwise

**12. Repeat steps 10 and 11 until torque tool A clicks (FIGURE 17).**

Seating occurs when both captive screws are evenly torqued to 5 inch-lbs. (58 grams-meter). Torque tool A clicks when this adjustment specification is achieved.

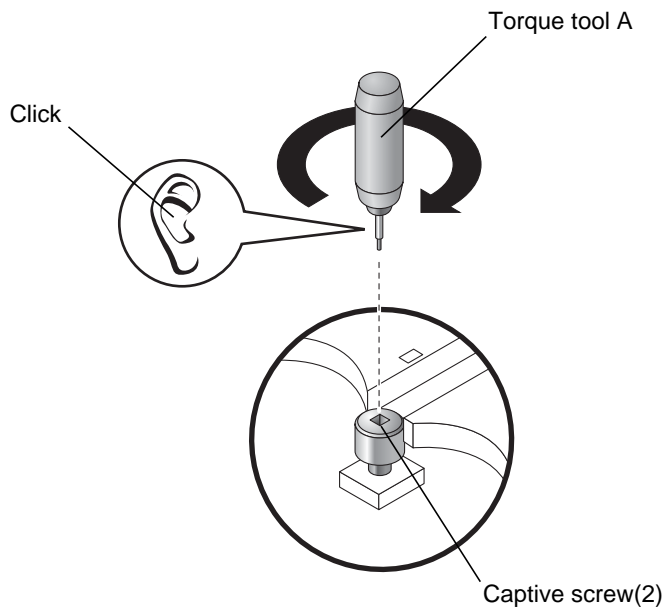

**FIGURE 17** Torque Tool A Clicks When the Captive Screws Are Correctly Torqued

13. Return torque tool A to its storage location in the workstation.
14. If necessary, reinstall the filler panel for the shroud.



---

**Caution** – To ensure proper workstation cooling, any unused CPU slot must contain a filler panel for the shroud (FIGURE 7).

---

15. Detach the antistatic wrist strap, replace the access panel, plug in the power cord, and power on the workstation.
16. Proceed to “Finishing the Installation” on page 25.



## Finishing the Installation

1. Remove the antistatic wrist strap from the chassis.
2. Replace the access panel.
3. Install a lock block on the back panel of the workstation.
4. Reconnect any cables from external devices to the workstation.
5. Reconnect the workstation power cord.
6. Power on the workstation:
  - a. Turn on power to the monitor and to all external devices.
  - b. Press the power switch on the front panel and release it.
  - c. After several seconds, verify that the power-indicator LED on the power switch is energized and listen to verify that the workstation fans are operating (spinning).
7. The workstation should automatically recognize installation of the new CPU module(s).

---

**Note** – Perform a reconfiguration boot (`boot -r`). If the workstation correctly boots, the CPU module has been correctly installed.

---

If problems are encountered, verify proper POST operation. See Section 3.4 “Maximum and Minimum Levels of POST” in the *Sun Blade 1000 and Sun Blade 2000 Service Manual*, 816-3217.

8. If you are returning a used CPU module to Sun Microsystems, return the used CPU module in the shipping box and packing materials that came with your new or replacement CPU module.

---

## Where to Find More Information

The *Sun Blade 1000 and Sun Blade 2000 Service Manual* is available from the following sources:

- The manual is shipped with new workstations in HTML and PDF formats on the *Sun Blade 1000 and Sun Blade 2000 Hardware Documentation CD (705-0073)*. The HTML version of the manual on this CD also includes this CPU replacement procedure as an animated ShowMe How™ multimedia procedure.
- A PDF version of this manual is available at:  
<http://www.sun.com/documentation/>